

# CX750

FINESTRE A BATTENTE A TAGLIO TERMICO  
*CASEMENT WINDOWS W/THERMAL BREAK*



**TWIN**  
**SYSTEMS**

ARCHITETTURE IN ALLUMINIO

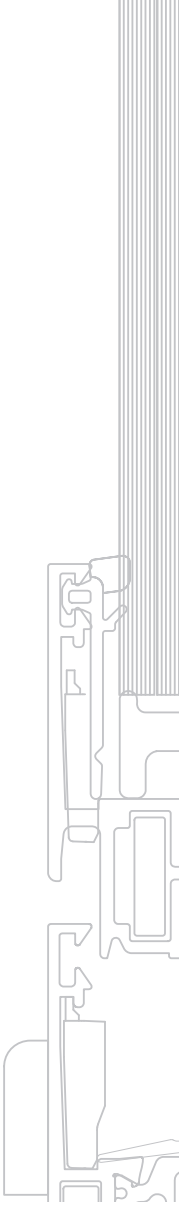

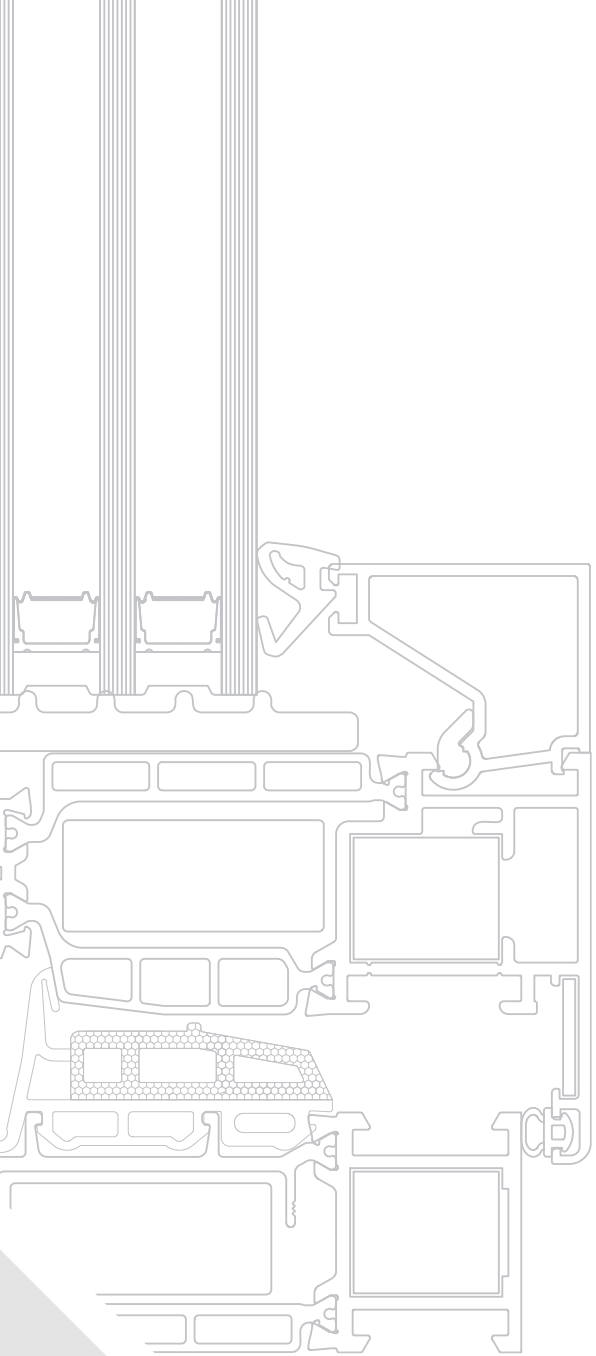

# CX750

FINESTRE A BATTENTE A TAGLIO TERMICO  
*CASEMENT WINDOWS W/THERMAL BREAK*







# TWIN SYSTEMS

ARCHITETTURE IN ALLUMINIO



## Gruppo A Informazioni Generali *Informazioni Generali*

Indice Generale  
Caratteristiche Alluminio  
Descrizione Tecnica sistema  
Descrizione Tecnica Capitolato  
Collaudi Prestazionali

*Table of Contents  
Aluminium Characteristics  
Technical Description  
Technical Specifications  
Performance Tests*

## Gruppo B Profili *Profiles*

Elenco Profili  
Profili Scala 1:1

*Profiles List  
Profiles Scale 1:1*

## Gruppo C Accessori e Guarnizioni *Accessories and Gaskets*

Elenco accessori  
Elenco guarnizioni

*List of Accessories  
List of Window Gaskets*

## Gruppo D Nodi *Main Sections*

Sezioni principali  
e Accessori  
Sc. 1:1

*Main Sections and  
Accessories  
Scale 1:1*

## Gruppo E Tipologie *Types*

Tipologie

*Types*

## Gruppo F Attacco alla Muratura *Wall Joint*

Sezione particolareggiata  
attacco alla muratura

*Wall Joint Detail*

## Gruppo G Lavorazioni/Montaggi *Tooling/Assembly*

Schemi Lavorazioni  
Frese  
Attrezzatura

*Tooling Systems  
Cutters Equipments  
Milling*

Tutti i dati riportati sul presente catalogo sono indicativi e non impegnativi. La società si riserva il diritto di apportare in qualsiasi momento modifiche atte a migliorare i prodotti. Per informazioni tecniche riguardanti il catalogo contattare l'ufficio tecnico.

*All the data shown in this catalog are indicative and not binding. The company reserves the right to make changes to improve the products at any time. For technical information regarding the catalog, contact the technical department.*





**Informazioni Generali**  
*General Information*

**Gruppo A**

Indice Generale	<i>Table of Contents</i>
Caratteristiche Alluminio	<i>Aluminium Characteristics</i>
Descrizione Tecnica sistema	<i>Technical Description</i>
Descrizione Tecnica Capitolato	<i>Technical Specifications</i>
Collaudi Prestazionali	<i>Performance Tests</i>

**PESO PROFILATI**

Il peso indicato è quello teorico e potrà variare in funzione delle tolleranze di spessore e dimensionali dei profilati (NORMA UNI EN 12020-2)

**LEGA DI ESTRUSIONE**

I profilati sono estrusi in lega EN-AW-6060 (UNI EN 573/3)

**DIMENSIONI DEI PROFILATI**

Le dimensioni indicate sono quelle teoriche, potranno quindi variare in funzione delle tolleranze dimensionali di estrusione (norma UNI EN 12020-2). Questa variabilità che interessa tutti i profilati, può influire, anche se minimamente, sulle dimensioni di taglio e quindi finali del serramento. Anche la verniciatura, aumentando gli spessori, contribuisce a far variare la dimensione dei profilati e, particolarmente, riduce lo spazio nelle sedi di inserimento delle guarnizioni e degli accessori.

**DIMENSIONI DI TAGLIO E LAVORAZIONI**

Le dimensioni teoriche di taglio e le quote delle lavorazioni indicate nel presente catalogo sono esatte, ovvero matematicamente corrette, in certi casi dovranno, nella pratica, essere adattate in base alla precisione ed al tipo di impostazione delle misure delle macchine utilizzate. È pertanto consigliabile nei primi lavori o nel caso di importanti quantità di serramenti effettuare delle campionature di prova.

**PROTEZIONE SUPERFICIALE**

Al fine di limitare i processi di corrosione filiforme è importante applicare le seguenti regole:

- ◆ Utilizzare accessori di assemblaggio in alluminio
- ◆ Utilizzare viti in acciaio inox
- ◆ Proteggere le parti tagliate e lavorate con prodotti idonei
- ◆ Evitare ristagni di condense all'interno dei profilati.

Per la realizzazione di serramenti è necessario attenersi alla tecnologia costruttiva e utilizzare le guarnizioni e gli accessori originali riportati sul catalogo tecnico e al rispetto delle norme, prescrizioni e raccomandazioni vigenti. L'osservanza di quanto sopra determina la garanzia.

Su queste basi sono stati realizzati campioni che, collaudati in laboratorio hanno ottenuto i risultati indicati nelle certificazioni. Per il buon funzionamento e la durata degli infissi realizzati con profilati ed accessori del sistema, è necessario effettuare alcune semplici operazioni: una buona pulizia, eliminando residui di calce, cemento e/o altro.

È consigliabile peraltro proteggere il manufatto sino al momento della messa in esercizio, lubrificare con olio o grasso neutri le parti in movimento e gli organi di chiusura, controllare il corretto serraggio delle viti e dei grani, controllare gli assetti, registrandoli laddove sono previste regolazioni. Si raccomanda di effettuare queste operazioni almeno con cadenza semestrale. In caso di funzionamento anomalo di qualche componente, evitare assolutamente interventi atti a modificarne le caratteristiche e la sostituzione con ricambi non originali. Ci sembra utile ricordare che interventi di regolazione e/o sostituzione, con particolare riferimento ai meccanismi per oscillo-battente, andranno eseguiti da personale specializzato. Si raccomanda inoltre, in occasione delle operazioni di pulizia, di non utilizzare detersivi che possano deteriorare i trattamenti superficiali, escludendo tassativamente acidi, solventi, materiali abrasivi, spazzole metalliche o comunque in grado di scalfire le superfici, pagliette metalliche e altro.

**WEIGHT OF PROFILES**

The weight indicated is the theoretical one and may vary depending on the thickness and dimensional tolerances of the profiles (STANDARD UNI EN 12020-2)

**EXTRUSION ALLOY**

The profiles are made of extrusion alloy EN-AW-6060 (UNI EN 573/3)

**DIMENSIONS OF PROFILES**

The dimensions indicated are the theoretical ones; they may vary depending on the extrusion dimensional tolerances (STANDARD UNI EN 12020-2). This variability, which affects all the profiles, can affect, even if minimally, the cutting size and, therefore, the final size of the window. Also the coating, increasing the thickness, affects the size of the profiles and, in particular, reduces the space in the housing of window gaskets and accessories.

**CUTTING AND TOOLING DIMENSIONS**

The theoretical cutting and tooling sizes indicated in this catalogue are accurate, that is, they are mathematically correct. In practice, in some cases they may need to be adapted to take into consideration the precision and dimensional settings of the machines used. We therefore recommend that test samples be made in the first jobs or in the case of large quantities of windows.

**SURFACE PROTECTION**

The rules below should be followed to limit filiform corrosion phenomena:

- ◆ Use aluminium assembly accessories
  - ◆ Use stainless steel screws
  - ◆ Use appropriate products to protect cut and tooled parts.
  - ◆ Prevent condensation from accumulating inside the profiles.
- When making the windows, comply with the construction technology, use original window gaskets and accessories as listed in the technical catalogue and comply with applicable standards, provisions and recommendations. Non-compliance with the above rules invalidates the warranty. Samples have been made on these bases that, tested in the laboratory, have obtained the results indicated in the certifications. Some simple actions are necessary for the proper functioning and durability of window frames made with the system's profiles and accessories: good cleaning, eliminating traces of lime, cement, etc.
- The product should be protected until the time of installation, lubricate moving parts and closing devices with neutral oil or grease, check that the screws and grub screws are tightened, check the trims, adjusting them where necessary. These operations should be carried out at least once every six months. Should any component not function correctly, do nothing to modify its characteristics and do not use non-original spare parts. Remember that adjustments and/or replacements, with special reference to tilt&turn mechanisms, must be carried out by specialized personnel.
- During cleaning operations, detergents that can damage surface treatments - e.g. acids, solvents, abrasive materials, metal brushes or in any case able to scratch the surfaces, steel wool, etc. - should not be used.



## DIMENSIONI E TIPOLOGIA DEI SERRAMENTI

La valutazione delle dimensioni dei serramenti, richiede la considerazione di vari fattori quali: il momento d'inerzia dei profilati, le dimensioni e il peso dei tamponamenti (vetri-pannelli), la larghezza e l'altezza delle parti apribili, caratteristiche e portate degli accessori, le condizioni e le quantità degli ancoraggi alle opere morte, l'esposizione, ecc... Fattori che sono valutabili e applicabili, grazie alla buona conoscenza dello stato dell'arte, alle informazioni riportate dai cataloghi, manuali tecnici e dalle normative vigenti. Consigliamo, al fine di evitare inutili contestazioni, di consultare il nostro servizio tecnico sistemi, prima di realizzare serramenti che, per dimensione, forma, esposizione e/o altro possono essere ritenuti atipici. Le soluzioni e le combinazioni proposte in questo catalogo, non hanno carattere limitativo, ma presentano solo le situazioni e combinazioni più comunemente riscontrabili nella realtà. Soluzioni e combinazioni diverse, così come l'adozione di componentistica particolare, ad esempio meccanismi per la realizzazione di ante scorrevoli parallele, ante scorrevoli a libro o altro, sono possibili. A questo proposito il nostro servizio tecnico prodotti per l'edilizia può valutare e proporre le soluzioni più idonee.

## DIMENSIONS AND TYPE OF WINDOWS

*Various factors must be taken into consideration when assessing the dimensions of the windows, such as: the moment of inertia of the profiles, the dimensions and weight of the panels (glass-panels), the width and height of the opening parts, the characteristics of the accessories, the condition and number of fastenings to the dead work, the exposure, etc. These factors can be assessed and applied, thanks to the good knowledge of the state of the art and to the information reported in catalogues, technical manuals and current regulations.*

*In order to avoid needless complaints, we invite you to contact our technical service before making windows that, due to their size, shape, exposure and/or other characteristic, could be considered non-standard. The solutions and combinations proposed in this catalogue are not the only ones available, but merely represent the most common situations and combinations. Different solutions and combinations, as well as the use of particular components, for example mechanisms for parallel sliding doors, folding sliding doors etc., are available. In this regard, our building products technical service can study and propose the most suitable solutions.*

**COMPOSIZIONE PROFILATI**

I profilati per serramenti saranno in lega di alluminio ENAW 6060 (EN 573-3 e EN 755-2) con stato fisico di fornitura UNI EN 515. I telai fissi e le ante mobili dovranno essere realizzati con profilati ad interruzione di ponte termico a tre camere (profilo interno ed esterno tubolari, collegati tra di loro con barrette inb poliammide PA6.6 rinforzate con fibra di vetro).

**INFISSI**

Le finestre e le porte finestre dovranno avere un profilato di telaio fisso con profondità minima 75 mm. ed un profilato di anta mobile con profondità minima 83 mm. I profilati di telaio fisso dovranno prevedere, dove necessario, alette incorporate di battuta interna sulla muratura da 22 mm.

I profilati di ante mobili dovranno avere un'aletta esterna di battuta per vetro con altezza di 22 mm ed una aletta di battuta interna sul telaio fisso con sormonto di 6 mm. La barretta in poliammide del profilato anta a contatto con la guarnizione di tenuta centrale (giunto aperto), dovrà essere di forma tubolare.

**ISOLAMENTO TERMICO**

L'interruzione del ponte termico sarà ottenuta da barrette continue in poliammide da 38-46 mm totale e dovrà garantire un valore di trasmittanza termica per l'infisso  $U_w = \dots\dots\dots W/m^2K$ . L'assemblaggio dei profilati in alluminio a taglio termico dovrà garantire i valori di scorrimento (T) tra profilati in alluminio e barrette in POLIAMMIDE previsti dalla direttiva tecnica Europea (UEAtc).

**DRENAGGI E VENTILAZIONE**

I profilati esterni delle ante mobili dovranno prevedere una gola ribassata per la raccolta delle acque di infiltrazione e di condensa onde poter permettere il libero deflusso delle stesse attraverso apposite asole di scarico. Le barrette in poliammide dovranno avere una conformazione geometrica atta ad evitare eventuale ristagno di acque di infiltrazione e di condensa ed essere perfettamente complanari con le pareti trasversali dei profilati di alluminio.

**ACCESSORI DI ASSEMBLAGGIO**

Le giunzioni tra profilati orizzontali e verticali dovranno essere perfettamente solidali e ben allineate tra di loro, sia nella parte esterna che interna dei profilati ed unite mediante apposite squadrette a bottone o, in alternativa, in alluminio estruso o pressofuso, con metodo a spino-cianfrinatura od a cianfrinatura totale. Le sezioni dei profilati orizzontali e verticali dovranno essere opportunamente sigillate prima di essere unite con le squadrette. I fermavetri saranno accoppiati a scatto e posizionati nei canali dei profilati in alluminio.

**GUARNIZIONI**

Tutte le guarnizioni: cingivetro, di tenuta, di battuta.... dovranno essere in elastomero (EPDM). In particolare la guarnizione di tenuta centrale (giunto aperto) dovrà assicurare la continuità perimetrale mediante l'impiego di angoli vulcanizzati preformati incollati alla stessa o in alternativa mediante telai vulcanizzati.

**PRESTAZIONI**

I serramenti dovranno avere prestazioni di permeabilità all'aria, tenuta all'acqua e resistenza ai carichi del vento conformemente alle norme:  
(UNI-EN 12207 - 12208 - 12210 e UNI-EN 1026 - 1027 - 12211)

**PROFILE COMPOSITION**

The window profiles are made of ENAW 6060 aluminum alloy (EN 573-3 and EN 755-2) with physical state of supply UNI EN 515. The fixed frames and sliding doors must be made with three-chamber thermal break profiles (tubular internal and external profile, connected to each other with glass fibre reinforced polyamide PA6.6 bars).

**DOORS AND WINDOWS**

The windows and French doors must have a fixed frame profile with a minimum depth of 75 mm and a sliding door profile with a minimum depth of 83 mm. Where necessary, the fixed frame profiles must have an incorporated 22 mm internal stop flap on the brickwork.

The profiles of sliding doors must have an external stop flap for glass with a height of 22 mm and an internal stop flap on the fixed frame with overlap of 6 mm. The polyamide bar of the door profile in contact with the central sealing gasket (open joint), must be tubular.

**THERMAL BREAK**

The thermal bridge will be interrupted using solid 38-46 mm polyamide bars guarantee a heat transmission value of the frame  $U_w = \dots\dots\dots W/m^2K$ . The assembly of aluminum profiles with thermal break will guarantee the slide values (T) between the aluminium profiles and polyamide bars set forth in the European Technical Directive (UEAtc).

**DRAINAGE AND VENTILATION**

The junctions between horizontal and vertical profiles must be perfectly integral and well aligned with each other; both in the external and internal part of the profiles and joined by means of special button brackets or, alternatively, in extruded or die-cast aluminum, with the pin-crimping method or with total crimping. The sections of the horizontal and vertical profiles must be properly sealed before being joined with the brackets. The glazing beads will be snap coupled and positioned in the channels of the aluminum profiles.

**ASSEMBLY ACCESSORIES**

The joints between the horizontal and vertical profiles must be perfectly united and correctly aligned with each other, both externally and internally and joined by means of special slot corner joints or, alternatively, in extruded or die-cast aluminum, with a dowel-crimping or full crimping method. The sections of the horizontal and vertical profiles must be properly sealed before being joined with the corner joints. The glazing beads will be snap-coupled and positioned in the channels of the aluminum profiles.

**WINDOW GASKETS**

All window gaskets: glazing, sealing, rabbet.... must be made of elastomer (EPDM). Specifically, the central sealing gasket (open joint) must ensure perimeter continuity using preformed vulcanized corner joints glued to it or, alternatively, vulcanized frames.

**PRESTAZIONI**

I serramenti dovranno avere prestazioni di permeabilità all'aria, tenuta all'acqua e resistenza ai carichi del vento conformemente alle norme:  
(UNI-EN 12207 - 12208 - 12210 e UNI-EN 1026 - 1027 - 12211)



**Labels in diagram:**

- Squadretta Allineamento Nylon o Serraggio Meccanico / Nylon or Mechanical Tightening Corner Joint
- Squadretta a Cianfrinare/Spinare / Riveting/crimping corner joint
- Sormonto Battuta 4 mm. / Rabbet overlap 4 mm.
- Precamera 4.01 cm<sup>3</sup> / Prechamber 4.01 cm<sup>3</sup>
- Squadretta Allineamento Nylon o Serraggio Meccanico / Nylon or Mechanical Tightening Corner Joint
- Squadretta a Cianfrinare/Spinare / Riveting/crimping corner joint
- Guarnizioni Tubolari Vetro / Tubular Glass Seals
- Fermavetro di Sicurezza H sede Vetro 22 mm. A Norma Europea / Safety-height glazing bead Glass Seat 22 mm. European standard
- Squadretta a Bottone/Cianfrinare/Spinare / Riveting/crimping corner joint
- Accessori a Camera Unificata / Unified Chamber Accessories
- Guarnizione Centrale a più Tubolarità / Multi-tubular Central Seal
- Guarnizione Battuta a Scatto ed Infilo / Snap-On Rabbet Weatherstrip
- Squadretta a Bottone/Cianfrinare/Spinare / Riveting/crimping corner joint

**Dimensions:** 75 mm (main width), 8 mm (track width)

**Icons:** 10 icons showing different window configurations and accessibility features.

CARATTERISTICHE FISICHE

Tecnologia:

- Sistema a camera multipla ad elevato isolamento termico con design simmetrico e qualità dell'assemblaggio garantita.
- Spessore dei tamponamenti fino a 55 mm.

FERRAMENTA:

- Sistema con accessori funzionali a camera unificata, spazio 11.5 mm. personalizzati ed a pista 16 mm.
- Giunzione angolare con squadrette a bottone/spinare/cianfrinare ed allineamento.

IMPIEGO:

- Profilati per finestre che consentono la costruzione di infissi ad una, due o più ante a battente, nella versione a giunto aperto coplanari all'esterno e a sormonto all'interno. Sono possibili anche specchiature fisse, wasistas, anta-ribalta. Profilati per porte: consentono la costruzione di porte ad una o due ante, apribili all'interno, con sopraluci fissi od apribili e vetrine.

PHYSICAL CHARACTERISTICS

Technology:

- High thermal break multi-glazing system with symmetrical design and guaranteed assembly quality.
- Panel thickness up to 55 mm.

HARDWARE:

- System with functional customized accessories with unified chamber, space 11.5 mm and track 16 mm.
- Corner joint with slot joints / dowelling/crimping and trimming.

USE:

- Window profiles for the construction of single-, double- or more-casement windows, in the open joint version coplanar on the outside and overlapping on the inside. Mirrored, transom, tilt&turn are also possible. Door profiles: allow the production of windows with single or double doors, openable from the inside, with fixed or openable hopper windows and glazing.

CARATTERISTICHE FISICHE | PHYSICAL CHARACTERISTICS

- ◆ Telaio Fisso | Fixed Frame: 75 mm.
- ◆ Telaio Mobile | Window Frame: 83 mm.
- ◆ Barrette Isolanti | Insulating Rods: 38 - 46 mm.
- ◆ Fuga Perimetrale | Perimeter Gap: 5 mm.
- ◆ Alloggiamento Accessori | Accessories Housing: Camera Europea dim. 11.5 mm. [European Chamber]
- ◆ Giunzione Angolare | Corner Joint: Bottone, Spinare, Cianfrinare [Dowelling/Crimping and Trimming Riveting Slot]

PRESTAZIONI CERTIFICATE | CERTIFIED PERFORMANCES

AAV

- ◆ Permeabilità all'aria | Air Permeability: Classe 4
- ◆ Tenuta all'acqua | Watertightness: Classe E 1500
- ◆ Carico di vento | Wind load resistance: Classe C5
- ◆ Isolamento acustico | Sound Insulation: fino a 47 dB
- ◆ Resistenza all'effrazione | Breakage resistance: Classe RC 3

Risultati dei test / CE product pass conforme ad:

Tests Results / CE product pass Compliant with:  
UNI EN 14351-1:2006+A1:2010

TRASMITTANZA | TRANSMITTANCE

- 1 ANTA | Single SASH:  $U_w = 1.11 \text{ W/(m}^2\text{K)}$
- 2 ANTE | Double SASH:  $U_w = 1.15 \text{ W/(m}^2\text{K)}$

SERRAMENTO CAMPIONE | SAMPLE FRAME

- ◆ Vetro Certificato | Certified Glass: Double Glazing  $U_g = 1.0 \text{ W/(m}^2\text{K)}$
- ◆ Canalina | Duct:  $\psi = 0.036 \text{ W/(m}^2\text{K)}$
- ◆ Finestra normalizzata | Normalized Window: H = 1480 mm. ed L = 1535 mm.

- 1 ANTA | Single SASH:  $U_w = 0.79 \text{ W/(m}^2\text{K)}$
- 2 ANTE | Double SASH:  $U_w = 0.86 \text{ W/(m}^2\text{K)}$

SERRAMENTO CAMPIONE | SAMPLE FRAME

- ◆ Vetro Certificato | Certified Glass: Triple Glazing  $U_g = 0.6 \text{ W/(m}^2\text{K)}$
- ◆ Canalina | Duct:  $\psi = 0.031 \text{ W/(m}^2\text{K)}$
- ◆ Finestra normalizzata | Normalized Window: H = 1480 mm. ed L = 1535 mm.

Dimensioni massime ammesse per il calcolo  $U_w$  su serramento campione fino a 2.3 m<sup>2</sup> (secondo norma UNI EN 14351-1:2006+A1:2010)

Maximum allowable dimensions for calculation of the  $U_w$  on sample window frame up to 2.3 m<sup>2</sup> (according to UNI EN 14351-1:2006+A1:2010)

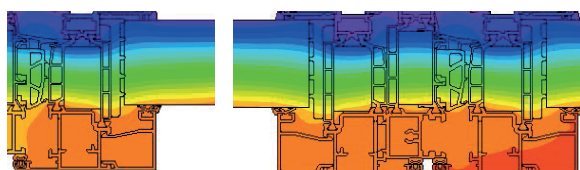

Analisi termica con FLIXO vers.8 e WinIso2D Professional 7.8  
Thermiccon FLIXO vers.8 e WinIso2D Professional 7.8



Tenuta all'Acqua  
Watertightness



Capacità di un inso di impedire infiltrazioni quando è investito da un flusso d'acqua ed è presente una differente pressione tra interno ed esterno.  
Capacity of a window to prevent infiltrations when impacted by a gush of water and there is a different internal and external pressure.

Press.	0Pa5	0Pa	100Pa	150Pa	200Pa	250Pa	300Pa	450Pa	600Pa	750Pa	900Pa	1050Pa	1200Pa	1350Pa	1500Pa	Pressure
Velocità	03	24	55	56	47	27	89	6	111	126	138	149	159	169	178	Speed
Classe	-1	A2	A3	A4	A5	A6	A7	A8	A	E750	E900	E1050	E1200	E1350	E1500	Class

L'infisso TWIN, con una pressione del vento pari ad una velocità di 178 Km/h (1500Pa) non ha avuto infiltrazioni  
The frame TWIN with a wind pressure equal to a speed of 178 Km/h (1500Pa), had no infiltrations

Classe | Class  
**E1500**  
EN 1027 - EN 12208

Tenuta all'Aria  
Air Permeability



Caratteristica di un inso chiuso di lasciare trarre aria quando è presente una differenza di pressione tra l'interno e l'esterno; minori saranno i volumi dispersi, maggiore sarà la qualità del serramento.  
Characteristic of a closed window to let air filter through when there is a different internal and external pressure; the lower the dispersed volumes, the higher the quality of the frame.

Press.	150Pa	300Pa	450Pa	600Pa	Pressure
Classe	1	2	3	4	Class

L'infisso TWIN ha superato la prova con Pressione Vento = 111 k/h (600Pa)  
The frame TWIN has passed the test with a Wind Pressure = 111 Km/h (600Pa)

Classe | Class  
**4**  
EN 1026 - EN 12207

Resist. al Vento  
Wind Resistance

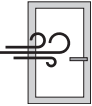

Capacità di un inso sottoposto a forti pressioni e/o depressioni, come quelle causate dal vento, di mantenere una deformazione ammissibile, di conservare le proprietà iniziali a salvaguardia della sicurezza degli utenti.  
Capacity of a window subject to high positive and/or negative pressures, like that caused by the wind, to maintain an admissible deformation, to conserve its initial properties and to safeguard users against breakage.

Press.	400Pa	800Pa	1200Pa	1600Pa	2000Pa	>2000Pa	Pressure
Flessione	A (≤ 1/150)	B (≤ 1/200)	C (≤ 1/300)				Flexure
Classe	12	34	5E	xxx			Class

\* Serramento a 2 ante, dimensione L = mm.1495 ed H = mm.1500 - Certificato n° RP n° 1994-CPD-RP1836 (Altre Certificazioni Disponibili)  
Double Casement window, dimension L = mm.1495 ed H = mm.1500 - Test certificate no. RP no. 1994-CPD-RP1836 (Other certifications available).

Classe | Class  
**C5**  
EN 12211-EN 12210

Fonoisolamento  
Sound Insulation



Perdita di isolamento acustico rispetto al vetro DR<sub>w</sub> (dB) a partire dalla classe di permeabilità all'aria dell'infisso (UNI EN 12207)  
Capacity of a window to resist violent intrusion following the application of a physical force or with the aid of tools.

Classe	1	2	3	4	Class	DR <sub>w</sub> ≤ 38 dB	Amnesso l'utilizzo di questo metodo tabellare
Perdita	8dB	6dB	4dB	2dB	Loss	DR <sub>w</sub> > 39 dB	Necessario realizzare un campione al vero e sottoporre a prove di Laboratorio.

Admitted This table method  
An actual sample must be made and tested in the laboratory.

Serramento a 1 anta, dimensione L = mm.1230 ed H = mm.1480 - Certificato n° RP n° 0559-RP-2023 (Altre Certificazioni Disponibili)  
Casement window, dimension L = mm.1230 ed H = mm.1480 - Test certificate no. RP no. 0559-RP-2023 (Other certifications available).

Abbattimento Acustico  
Noise Reduction  
**47 dB**  
EN ISO140-3 | 717-1

Trasmissione  
Transmittance

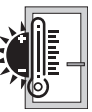

Flusso di calore che passa attraverso il serramento per m2 di superficie e per ogni grado di differenza di temperatura tra interno ed esterno.  
Flow of heat that passes through the window per m2 of surface and for every degree of difference in temperature between outdoors and indoors.

U <sub>w</sub>	<b>1.25 W/m²K</b>	Barrette INSULBAR LI	<b>1.21 W/m²K</b>	Barrette STEADYTECH
	Finestra a 2 ante normalizzata (1535 mm. x 1480 mm; vetro doppio U <sub>g</sub> =1.0 W/m²K certificato con canalina psi=0.036 W/m²K) Normalised 2 Sashes window (1535 mm x 1480 mm; double glazing U <sub>g</sub> =1.0 W/m²K certified with duct psi=0.036 W/m²K)			
U <sub>w</sub>	<b>0.96 W/m²K</b>	Barrette INSULBAR LI	<b>0.92 W/m²K</b>	Barrette STEADYTECH
	Finestra a 2 ante normalizzata (1535 mm. x 1480 mm; vetro triplo U <sub>g</sub> =0.6 W/m²K certificato con canalina psi=0.031 W/m²K) Normalised 2 Sashes window (1535 mm x 1480 mm; triple glazing U <sub>g</sub> =0.6 W/m²K certified with duct psi=0.031 W/m²K)			

Antieffrazione  
Breakege Resistance



Capacità di un infisso di resistere ad un'intrusione violenta a seguito di una applicazione di una forza fisica e con l'aiuto di attrezzi Finestra a 2 ante (1230 mm. x 1480 mm) - CERTIFICATO RT-480-2023  
Capacity of a window to resist violent intrusion following the application of a physical force or with the aid of tools. 2 sashes window (1230 mm x 1480 mm) - RT-480-2023 CERTIFIED door

Classe	<b>RC1</b>	<b>RC2</b>	<b>RC3</b>
Intrusione	Forza Fisica (Calci Pugni, Spallate)	Semplice Attrezzatura (Cunei, Cacciaviti)	R2 + Piede di Porco
Intrusion	Physical strength (kicks, pushing, pushing with shoulder)	Simple Tools (Wedges, Screwdrivers)	R2 + Crowbar

L'infisso TWIN, resiste in modo efficace ai tentativi di intrusione interna.  
The TWIN window effectively resists attempted breaks

Resistenza Effrazione  
Breakege Resistance  
**RC 3**



Battente una e Due Ante  
*Single and Double Sash Casement Window*

TIPO   Type	ARTICOLO   Item	PORTATA   Load Capacity
	<b>ACX 02.01</b> TOP RAPID CERNIERA A MONTAGGIO RAPIDO 2AlI <i>FAST INSTALLING HINGE 2Wings</i>	 <b>100% = 80Kg</b>
	<b>ACX 02.03</b> TOP RAPID CERNIERA A MONTAGGIO RAPIDO 3AlI <i>FAST INSTALLING HINGE 3Wings</i>	
	<b>ACX 02.01</b> TOP RAPID CERNIERA A MONTAGGIO RAPIDO 2AlI <i>FAST INSTALLING HINGE 2Wings</i>	 <b>100% = 80Kg</b>
	<b>ACX 02.03</b> TOP RAPID CERNIERA A MONTAGGIO RAPIDO 3AlI <i>FAST INSTALLING HINGE 3Wings</i>	

In alcuni schemi sono indicate cerniere in colore blu ed è suggerita l'applicazione per finestre/porte in ambienti pubblici.  
*Some diagrams show blue hinges and suggest their use for windows/doors in public areas.*

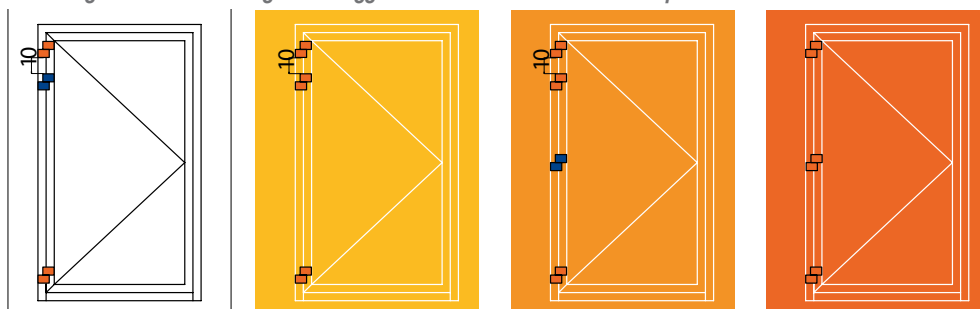

2800	100%	100%	100%	100%	100%	100%	100%	100%	100%
2700	100%	100%	100%	100%	100%	100%	100%	100%	100%
2600	100%	100%	100%	100%	100%	100%	100%	100%	100%
2500	100%	100%	100%	100%	100%	100%	100%	100%	100%
2400	100%	100%	100%	100%	100%	100%	100%	100%	100%
2300	100%	100%	100%	100%	100%	100%	100%	100%	100%
2200	100%	100%	100%	100%	100%	100%	100%	100%	97%
2100	100%	100%	100%	100%	100%	100%	100%	100%	90%
2000	100%	100%	100%	100%	100%	100%	100%	94%	83%
1900	100%	100%	100%	100%	100%	100%	98%	86%	76%
1800	100%	100%	100%	100%	100%	100%	90%	78%	69%
1700	100%	100%	100%	100%	100%	95%	82%	71%	61%
1600	100%	100%	100%	100%	100%	85%	73%	63%	54%
1500	100%	100%	100%	100%	90%	76%	65%	55%	N.D.
1400	100%	100%	100%	96%	80%	67%	57%	N.D.	N.D.
1300	100%	100%	100%	84%	70%	58%	N.D.	N.D.	N.D.
1200	100%	100%	90%	73%	100%	N.D.	N.D.	N.D.	N.D.
1100	100%	97%	78%	62%	100%	N.D.	N.D.	N.D.	N.D.
1000	100%	83%	65%	51%	N.D.	N.D.	N.D.	N.D.	N.D.
	<b>600</b>	<b>700</b>	<b>800</b>	<b>900</b>	<b>1000</b>	<b>1100</b>	<b>1200</b>	<b>1300</b>	<b>1400</b>

**Legenda Stringa di Prodotto / Product String Key**

(1) Cat. D'Uso Cat. of Use	(2) Durabilità Durability	(3) Massa Mass	(4) Resist. Fuoco Fire Resistance	(5) Sicurezza D'Uso Safety of Use	(6) Resist. Corrosione Corrosion Resist.	(7) Effrazione Breakage	(8) Grado Degree
<b>1= Leggero</b> <i>Lightweigh</i>	3:10'000	2: 40Kg	0: Non Idoneo. <i>Not Suitable</i>	1: Soddisfatto. <i>Met</i>	4: 240h in nebbia salina in accordo a UNI EN 1670:2008.  <i>240h in salt spray in accordance with UNI EN 1670:2008</i>	<b>1</b>	Valore: Combinazione di Massa e cicli. <i>Combination of Mass and Cycles</i>
<b>2= Medio</b> <i>Medium</i>	4:25.000	3: 60 Kg					
<b>3= Pesante</b> <i>Heavy</i>	7:200.000	4: 80 Kg					
<b>4= Intenso</b> <i>vIntense</i>							



Battente una e Due Ante  
*Single and Double Sash Casement Window*

ARTICOLO   Item		PORTATA   Load Capacity
<b>ARX 08.09 TOP RAPID</b> CERNIERA A MONTAGGIO RAPIDO 2AlI <i>FAST INSTALLING HINGE 2Wings</i>		<b>100% = 80Kg</b>
<b>ARX 08.09 TOP RAPID + VITE</b> CERN A MONT. RAPIDO 2AlI + VITE <i>FAST INSTALLING HINGE 2Wings + Screw</i>		<b>100% = 120Kg</b>

In alcuni schemi sono indicate cerniere in colore blu ed è suggerita l'applicazione per finestre/porte in ambienti pubblici.  
*Some diagrams show blue hinges and suggest their use for windows/doors in public areas.*

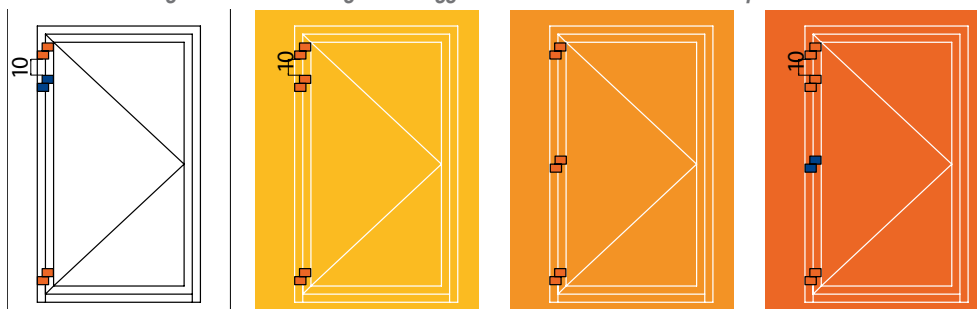

<b>2800</b>	100%	100%	100%	100%	100%	100%	100%	100%	100%
<b>2700</b>	100%	100%	100%	100%	100%	100%	100%	100%	100%
<b>2600</b>	100%	100%	100%	100%	100%	100%	100%	100%	100%
<b>2500</b>	100%	100%	100%	100%	100%	100%	100%	100%	100%
<b>2400</b>	100%	100%	100%	100%	100%	100%	100%	100%	100%
<b>2300</b>	100%	100%	100%	100%	100%	100%	100%	100%	100%
<b>2200</b>	100%	100%	100%	100%	100%	100%	100%	100%	97%
<b>2100</b>	100%	100%	100%	100%	100%	100%	100%	100%	90%
<b>2000</b>	100%	100%	100%	100%	100%	100%	100%	94%	83%
<b>1900</b>	100%	100%	100%	100%	100%	100%	98%	86%	76%
<b>1800</b>	100%	100%	100%	100%	100%	100%	90%	78%	69%
<b>1700</b>	100%	100%	100%	100%	100%	95%	82%	71%	61%
<b>1600</b>	100%	100%	100%	100%	100%	85%	73%	63%	54%
<b>1500</b>	100%	100%	100%	100%	90%	76%	65%	55%	N.D.
<b>1400</b>	100%	100%	100%	96%	80%	67%	57%	N.D.	N.D.
<b>1300</b>	100%	100%	100%	84%	70%	58%	N.D.	N.D.	N.D.
<b>1200</b>	100%	100%	90%	73%	100%	N.D.	N.D.	N.D.	N.D.
<b>1100</b>	100%	97%	78%	62%	100%	N.D.	N.D.	N.D.	N.D.
<b>1000</b>	100%	83%	65%	51%	N.D.	N.D.	N.D.	N.D.	N.D.
	<b>600</b>	<b>700</b>	<b>800</b>	<b>900</b>	<b>1000</b>	<b>1100</b>	<b>1200</b>	<b>1300</b>	<b>1400</b>

**Legenda Stringa di Prodotto / Product String Key**

(1) Cat. D'Uso Cat. of Use	(2) Durabilità Durability	(3) Massa Mass	(4) Resist. Fuoco Fire Resistance	(5) Sicurezza D'Uso Safety of Use	(6) Resist. Corrosione Corrosion Resist.	(7) Effrazione Breakage	(8) Grado Degree
<b>1= Leggero</b> <i>Lightweigh</i>	3:10'000	2: 40Kg	0: Non Idoneo. <i>Not Suitable</i>	1: Soddisfatto. <i>Met</i>	4: 240h in nebbia salina in accordo a UNI EN 1670:2008.  240h in salt spray in accordance with UNI EN 1670:2008	<b>1</b>	Valore: Combinazione di Massa e cicli. <i>Combination of Mass and Cycles</i>
<b>2= Medio</b> <i>Medium</i>	4:25.000	3: 60 Kg					
<b>3= Pesante</b> <i>Heavy</i>	7:200.000	4: 80 Kg					
<b>4= Intenso</b> <i>vintense</i>							



**Profili Porte Applicazione Esterna**  
*Profiles for External Application*

TIPO   Type	ARTICOLO   Item	PORTATA   Load Capacity
	<b>ARX 02.12</b> CERNIERA PER PORTE REGISTRABILE 2Alì <i>ADJUSTABLE HINGE FOR DOOR 2Wings</i>	<b>100% = 160Kg</b>
	<b>ARX 02.13</b> CERNIERA PER PORTE REGISTRABILE 3Alì <i>ADJUSTABLE HINGE FOR DOOR 3Wings</i>	<b>100% = 200Kg</b>

In alcuni schemi sono indicate cerniere in colore blu ed è suggerita l'applicazione per finestre/porte in ambienti pubblici.  
*Some diagrams show blue hinges and suggest their use for windows/doors in public areas.*

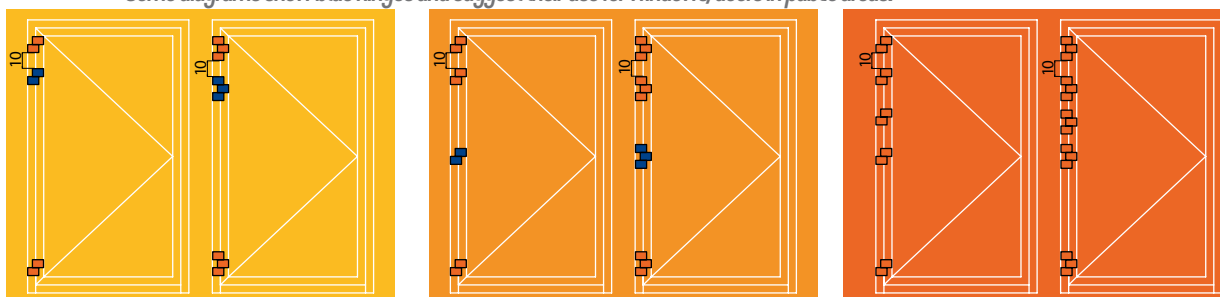



3300-4000	100%	100%	100%	100%	100%	100%	100%	100%	100%	100%	100%	100%	100%	100%	100%
3200	100%	100%	100%	100%	100%	100%	100%	100%	100%	100%	100%	100%	100%	100%	100%
3100	100%	100%	100%	100%	100%	100%	100%	100%	100%	100%	100%	100%	100%	100%	95%
3000	100%	100%	100%	100%	100%	100%	100%	100%	100%	100%	100%	100%	100%	98%	90%
2900	100%	100%	100%	100%	100%	100%	100%	100%	100%	100%	100%	100%	100%	93%	85%
2800	100%	100%	100%	100%	100%	100%	100%	100%	100%	100%	100%	100%	100%	100%	80%
2700	100%	100%	100%	100%	100%	100%	100%	100%	100%	100%	100%	99%	90%	82%	75%
2600	100%	100%	100%	100%	100%	100%	100%	100%	100%	100%	100%	93%	84%	77%	70%
2500	100%	100%	100%	100%	100%	100%	100%	100%	100%	100%	96%	87%	79%	72%	65%
2400	100%	100%	100%	100%	100%	100%	100%	100%	100%	100%	90%	81%	73%	66%	60%
2300	100%	100%	100%	100%	100%	100%	100%	100%	100%	93%	84%	75%	68%	61%	55%
2200	100%	100%	100%	100%	100%	100%	100%	100%	97%	87%	78%	69%	62%	56%	50%
2100	100%	100%	100%	100%	100%	100%	100%	100%	90%	80%	71%	64%	57%	51%	45%
2000	100%	100%	100%	100%	100%	100%	100%	94%	83%	73%	65%	58%	51%	45%	40%
1900	100%	100%	100%	100%	100%	100%	98%	86%	76%	67%	59%	52%	46%	40%	35%
1800	100%	100%	100%	100%	100%	100%	90%	78%	69%	60%	53%	46%	40%	35%	30%
1700	100%	100%	100%	100%	100%	95%	82%	71%	61%	53%	46%	40%	34%	29%	25%
1600	100%	100%	100%	100%	100%	85%	73%	63%	54%	47%	40%	34%	29%	24%	20%
1500	100%	100%	100%	100%	90%	76%	65%	55%	47%	40%	34%	28%	23%	N.D.	N.D.
1400	100%	100%	100%	96%	80%	67%	57%	48%	40%	33%	28%	22%	N.D.	N.D.	N.D.
1300	100%	100%	100%	84%	70%	58%	48%	40%	33%	27%	21%	N.D.	N.D.	N.D.	N.D.
1200	100%	100%	90%	73%	60%	49%	40%	32%	26%	20%	N.D.	N.D.	N.D.	N.D.	N.D.
1100	100%	97%	78%	62%	50%	40%	32%	25%	N.D.	N.D.	N.D.	N.D.	N.D.	N.D.	N.D.
1000	100%	83%	65%	51%	40%	31%	23%	N.D.	N.D.	N.D.	N.D.	N.D.	N.D.	N.D.	N.D.
	600	700	800	900	1000	1100	1200	1300	1400	1500	1600	1700	1800	1900	2000

**Legenda Stringa di Prodotto / Product String Key**

(1) Cat. D'Uso Cat. of Use	(2) Durabilità Durability	(3) Massa Mass	(4) Resist. Fuoco Fire Resistance	(5) Sicurezza D'Uso Safety of Use	(6) Resist. Corrosione Corrosion Resist.	(7) Effrazione Breakage	(8) Grado Degree
1= Leggero <i>Lightweigh</i>	3:10'000	2: 40Kg	0: Non Idoneo. <i>Not Suitable</i>	1: Soddisfatto. <i>Met</i>	4: 240h in nebbia salina in accordo a UNI EN 1670:2008.  240h in salt spray in accordance with UNI EN 1670:2008	1	Valore: Combinazione di Massa e cicli. <i>Combination of Mass and Cycles</i>
2= Medio <i>Medium</i>	4:25.000	3: 60 Kg					
3= Pesante <i>Heavy</i>	7:200.000	4: 80 Kg	1: Idoneo. <i>Met</i>				
4= Intenso <i>Intense</i>							

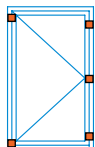

**Profili Porte Applicazione Esterna**  
*Profiles for External Application*

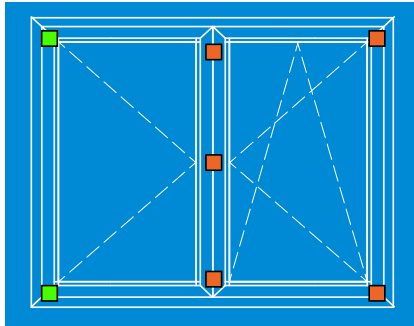
TIPO   Type	ARTICOLO   Item	PORTATA   Load Capacity	VITE OBBLIGATORIA   Mandatory Screw
■	<b>ACX 08.01</b> KIT BASE ANTA RIBALTA WEEN <i>ATILT AND TURN KIT WEEN</i>	<b>100% = 160Kg</b>	 <b>&gt;100KG</b> <b>&lt;160Kg</b> + 
	<b>ARX 08.01L</b> KIT BASE ANTA RIBALTA WEEN LOGICA <i>ATILT AND TURN KIT WEEN LOGICA</i>		
■	<b>ACX 08.48</b> KIT BASE ANTA RIBALTA WEEN LOGICA <i>ATILT AND TURN KIT WEEN LOGICA</i>	<b>100% = 200Kg</b>	
	<b>ARX 08.48L</b> KIT BASE ANTA RIBALTA WEEN LOGICA <i>ATILT AND TURN KIT WEEN LOGICA</i>		

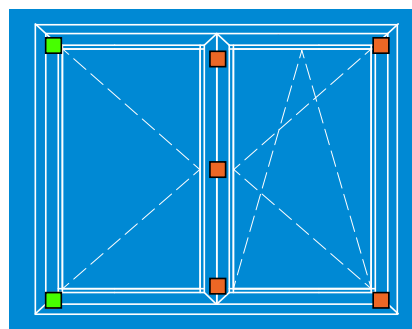
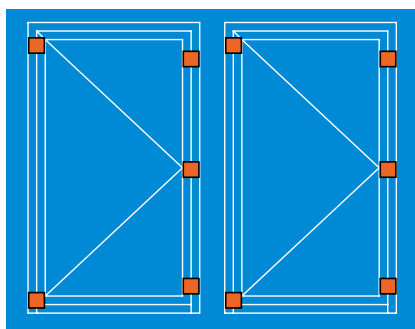

■ Negli schemi sono indicate cerniere in colore verde per anta affiancata art. **ACX.08.48**  
*The diagrams show green hinges for side-by-side doors - item ACX.08.48*

2700	50	50	47	40	34	30	26	24	22	20	18	17	16	15	14
2600	50	50	49	41	35	31	27	25	22	21	19	18	16	15	14
2500	50	50	50	43	37	32	28	26	23	21	20	18	17	16	15
2400	50	50	50	44	38	33	30	27	24	22	21	19	18	17	16
2300	50	50	50	46	40	35	31	28	25	23	21	20	19	17	16
2200	50	50	50	48	42	36	32	29	26	24	22	21	19	18	17
2100	50	50	50	50	44	38	34	30	28	25	23	22	20	19	16
2000	50	50	50	50	46	40	36	32	29	27	25	23	21	20	17
1900	50	50	50	50	48	42	37	34	31	28	26	24	22	19	18
1800	50	50	50	50	50	44	40	36	32	30	27	25	21	20	19
1700	50	50	50	50	50	47	42	38	34	31	29	24	23	21	20
1600	50	50	50	50	50	50	44	40	36	33	28	26	24	23	18
1500	50	50	50	50	50	50	47	43	39	36	30	27	26	20	15
1400	50	50	50	50	50	50	50	46	42	34	32	29	23	17	16
1300	50	50	50	50	50	50	50	49	40	37	34	26	20	18	12
1200	50	50	50	50	50	50	50	48	44	40	31	23	21	13	6
1100	50	50	50	50	50	50	50	50	48	36	27	25	16	7x	x
1000	50	50	50	50	50	50	50	50	44	32	30	18	9x	x	x
900	50	50	50	50	50	50	50	43	39	24	11	x	x	x	x
800	50	50	50	50	50	50	50	48	29	13	x	x	x	x	x
700	50	50	50	50	50	50	50	18	x	x	x	x	x	x	x
600	50	50	50	50	50	50	24	x	x	x	x	x	x	x	x
500	50	50	50	50	50	x	x	x	x	x	x	x	x	x	x
	370	400	500	600	700	800	900	1000	1100	1200	1300	1400	1500	1600	1700

Legenda Stringa di Prodotto / Product String Key							
(1) Cat. D'Uso Cat. of Use	(2) Durabilità Durability	(3) Massa Mass	(4) Resist. Fuoco Fire Resistance	(5) Sicurezza D'Uso Safety of Use	(6) Resist. Corrosione Corrosion Resist.	(7) Effrazione Breakage	(8) Grado Degree
1= Leggero <i>Lightweigh</i>	3:10'000	2: 40Kg	0: Non Idoneo. <i>Not Suitable</i>	1: Soddisfatto. <i>Met</i>	4: 240h in nebbia salina in accordo a UNI EN 1670:2008. <i>240h in salt spray in accordance with UNI EN 1670:2008</i>	1	Valore: Combinazione di Massa e cicli. <i>Combination of Mass and Cycles</i>
2= Medio <i>Medium</i>	4:25.000	3: 60 Kg					
3= Pesante <i>Heavy</i>	7:200.000	4: 80 Kg					
4= Intenso <i>Intense</i>							

LA MARCATURA CE DELLE FINESTRE E PORTE PEDONALI  
[Senza caratteristiche di resistenza al fuoco e/o di tenuta al fumo]

Il marchio CE, apposto sui prodotti da costruzione, attesta la loro conformità ai requisiti essenziali definiti dalla direttiva 89/106/CE "Prodotti da costruzione", emanata dal Consiglio della Comunità Europea il 21/12/1988 ed attuata, in Italia, dal D.P.R. n. 246 del 21/04/1993. La marcatura CE di uno specifico prodotto da costruzione diviene obbligatoria, al fine di immettere il prodotto in un mercato della Comunità Europea, allorché sia stata emessa dal CEN, su mandato della Comunità Europea, una "specificazione tecnica" (norma o benessere tecnico) che regolamenti la sua applicazione.

La responsabilità per la verifica dei requisiti del prodotto e per l'apposizione della marcatura CE spetta al suo fabbricante.

Al fine di garantire i requisiti richiesti dalle relative norme, il fabbricante è tenuto a:

- ◆ Predisporre un piano di controllo della produzione (FPC). E' un sistema di procedure e controlli da eseguire durante le fasi di produzione
- ◆ Effettuare delle "prove iniziali di tipo" (ITT) sul prodotto al fine di determinare le prestazioni. Le modalità di prova dei requisiti del prodotto sono definite dalle norme richiamate dalla specifica norma prodotto".

Alcune prove possono essere eseguite dal produttore stesso, secondo le disposizioni delle relative norme armonizzate, mentre altri requisiti sono di competenza di laboratori in possesso di una notifica attribuita loro dallo stato membro di appartenenza (organismi notificati).

IL FABBRICANTE PUO' PROCEDERE IN PIU' MODI

- ◆ Eseguire autonomamente i test sui propri prodotti presso un istituto Notificato, diventando quindi titolare degli ITT
- ◆ Far riferimento ai risultati di prove effettuate dal detentore del sistema di serramento, purché quest'ultimo abbia espresso il proprio consenso per mezzo di un contratto di licenza d'uso stipulato tra le parti.

Da Febbraio 2010 è obbligatoria la marcatura CE per finestre e porte pedonabili senza caratteristiche di resistenza al fuoco e tenuta al fumo.

L'appendice ZA della norma UNI EN 14351-1 specifica le caratteristiche essenziali per finestre e porte e attribuisce le competenze delle prove iniziali di tipo.

Il requisito relativo ad una determinata caratteristica non è applicabile in quegli Stati Membri nei quali non sussistono requisiti di regolamentazione per tale caratteristica per l'impiego previsto del prodotto. In questo caso, i fabbricanti che immettono i loro prodotti sul mercato di questi Stati membri non sono obbligati a determinare né a dichiarare le prestazioni dei loro prodotti in relazione a questa caratteristica e può essere utilizzata l'opzione "Nessuna Prestazione Determinata" (NPD) nelle informazioni che accompagnano la marcatura CE (vedere punto ZA.3). Tuttavia, l'opzione NPD non può essere utilizzata nel caso in cui la caratteristica sia soggetta a un livello soglia. [Citazione integrale tratta dalla norma UNI EN 14351-1 - appendice ZA]

## CE MARKING OF PEDESTRIAN WINDOWS AND DOORS

### [Without fire resistance and/or smoke resistance characteristics]

*The CE marking, affixed to products, certifies their compliance with the essential requirements of Directive 89/106/EC "Construction products", issued by the Council of the European Community on 21/12/1988 and implemented, in Italy, by Presidential Decree no. 246 of 21/04/1993. The CE marking of a specific product is mandatory when the product is to be placed on a European Community market, whenever a "technical specification" (standard or technical approval) that regulates its application has been issued by CEN, under mandate of the European Community.*

*The manufacturer is responsible for verifying product requirements and affixing the CE marking. To ensure fulfilment of the requirements of the relevant standards, the manufacturer must:*

- ◆ **Draw up a production control plan (PCP). This system of procedures and controls are performed during the production stages.**
- ◆ **Carry out "initial type tests" (ITT) on the product in order to determine performance. The test methods of the product requirements are defined by the standards referred to in the specific product standard ".**

*Some tests can be carried out by the manufacturer, in accordance with the provisions of the relevant harmonised standards, while others are the responsibility of laboratories awarded notified body status by their Member State (notified bodies).*

#### THE MANUFACTURER MAY PROCEED IN SEVERAL WAYS:

- ◆ **Carry out the tests on its products independently at a Notified Body, thus becoming the holder of the ITTs**
- ◆ **Refer to the results of tests carried out by the holder of the window and door system, provided that the latter has given his consent by means of a user licence agreement signed by the parties.**

*From February 2010, CE marking is mandatory for pedestrian windows and doors without fire resistance and smoke resistance characteristics.*

**Appendix ZA of standard UNI EN 14351-1 specifies the essential characteristics for windows and doors and attributes responsibilities for the initial type tests.**

*The requirement for a given characteristic does not apply in the Member States where there are no regulatory requirements for that characteristic for the intended use of the product. In this case, manufacturers who place their products on the market of these Member States shall not be obliged to determine or to declare the performance of their products for same characteristic and the "No Performance Determined" (NPD) option may be used in the information accompanying the CE marking (see point ZA.3). However, the NPD option cannot be used when the characteristic is subject to a threshold level. (Full quote from UNI EN 14351-1 - Appendix ZA)*



Per finestre e porte senza funzione di compartimentazione del fuoco o fumo e non poste nelle vie di fuga (sistema di attestazione della conformità 3):

For windows and doors without a fire or smoke compartmentalization function and not located in run off areas (conformity attestation system 3):

CARATTERISTICHE FONDAMENTALI FUNDAMENTAL CHARACTERISTICS	Espressioni di Prestazione Expressions of Performance	Competenze Prove Iniziali Tipo   Initial Type Test Responsibilities		
		ON= Organismo Notificato; PR= Produttore   ON=Notified Body; PR= Manufacturer		
		Finestre   Windows	Porte   Doors	Lucernari   Hopper Windows
<b>Comportamento al FUOCO Dall'Esterno</b> <i>External Fire Behaviour</i>				<b>ON</b>
<b>Resistenza al FUOCO</b> <i>Fire Reaction</i>	<b>Euroclassi</b> <i>Euroclasses</i>			<b>ON</b>
<b>Tenuta all'ACQUA</b> <i>Watertightness</i>	<b>Classi Tecniche</b> <i>Technical Classes</i>	<b>ON</b>	<b>ON</b>	<b>ON</b>
<b>Sostanze Pericolose</b> <i>Hazardous Substances</i>		<b>ON</b>	<b>ON</b>	
<b>Resistenza al Carico del VENTO</b> <i>Wind Load Resistance</i>	<b>Classi Tecniche</b> <i>Technical Classes</i>	<b>ON</b>	<b>ON</b>	<b>PR</b>
<b>Resistenza al Carico della NEVE e Carico Premanente</b> <i>Snow Load and Permenent Load</i>	<b>Classi Tecniche</b> <i>Technical Classes</i>			<b>PR</b>
<b>Resistenza all'URTO</b> <i>Shock Resistance</i>	<b>KN/m<sup>2</sup></b> <i>KN/sqm</i>		<b>PR</b>	<b>ON</b>
<b>Capacità Portante dei Dispositivi di Sicurezza</b> <i>Load-bearing Capacity of Savety evices</i>	<b>Soglia</b>	<b>ON</b>	<b>ON</b>	<b>ON</b>
<b>Altezza</b> <i>Height</i>	<b>mm.</b>		<b>PR</b>	
<b>Forze di azionamento (solo dispositivi automatici)</b> <i>Operating forces (automatic devices only)</i>	<b>Classi Tecniche</b> <i>Technical Classes</i>		<b>ON</b>	
<b>Prestazione acustica</b> <i>Acoustic Performance</i>	<b>dB</b>	<b>ON</b>	<b>ON</b>	<b>ON</b>
<b>Trasmittanza termica</b> <i>Heat Transmittance</i>	<b>W/m<sup>2</sup>K</b>	<b>ON</b>	<b>ON</b>	<b>ON</b>
<b>Proprietà radioattive</b> <i>Radioactive properties</i>				<b>PR</b>
<b>Permeabilità all'ARIA</b> <i>AIR Permeability</i>	<b>Classi Tecniche</b> <i>Technical Classes</i>	<b>ON</b>	<b>ON</b>	<b>PR</b>

La valutazione delle caratteristiche da dichiarare è funzione della destinazione d'uso del prodotto e della legislazione vigente nello Stato Membro, ove esso è immesso.

*The characteristics to be declared depend on the intended use of the product and the legislation in force in the Member State where it is sold.*



## TEST INIZIALI di TIPO (ITT)

La serie riportata nel presente catalogo è stata sottoposta a test iniziali di tipo (ITT) relativamente ai requisiti previsti dalla norma prodotto UNI EN 14351-1. I risultati dei test iniziali di tipo sono estendibili a serramenti di differente tipologia e con differenti dimensioni e componenti, secondo le indicazioni fornite dalla norma EN 14351-1 in Appendice A (interdipendenza fra le caratteristiche e i componenti), Appendice E (determinazione delle caratteristiche) ed Appendice F (selezione facoltativa di provini rappresentativi per le finestre)

Il costruttore di serramenti ha la responsabilità di verificare la rispondenza del serramento prodotto rispetto al campione sottoposto a prova. Il consorzio TWIN Systems mette a disposizione dei propri clienti i risultati dei test effettuati, a seguito della stipulazione di un contratto d'uso gratuito degli stessi.

### Dichiarazione di Conformità

Il fabbricante del serramento è tenuto a consegnare al committente una dichiarazione di conformità la quale, in accordo alla norma UNI EN 14351-1, deve includere :

- ◆ Nome ed indirizzo del fabbricante o del suo rappresentante autorizzato con sede nella EEA;
- ◆ Descrizione del prodotto (tipo, identificazione, impiego, ecc.) e una copia delle informazioni che accompagnano la marcatura CE;
- ◆ Disposizioni alle quali il prodotto è conforme ( appendice AZ della norma prodotto UNI EN 14351-1);
- ◆ Condizioni particolari applicabili all'impiego del prodotto (per esempio disposizioni per l'impiego in determinante condizioni, ecc.);
- ◆ Nome e indirizzo del/i laboratorio/i approvato/i.
- ◆ Nome e qualifica della persona incaricata di firmare la dichiarazione per conto del fabbricante o del suo rappresentante autorizzato.

La dichiarazione e il certificato devono essere presentati nella lingua o nelle lingue ufficiali dello Stato Membro in cui il prodotto deve essere utilizzato.

### Etichettatura e Marcatura

Il fabbricante deve fornire informazioni sufficienti ad assicurare la rintracciabilità del suo prodotto fornendo il collegamento fra il prodotto, il fabbricante e la produzione. Queste informazioni devono essere contenute su un'etichetta o specificate in documenti di accompagnamento nelle specifiche tecniche pubblicate dal fabbricante. Le informazioni seguenti devono accompagnare il simbolo di marcatura CE:

- ◆ Nome e indirizzo registrato o marchio di identificazione del fabbricante;
- ◆ Ultime due cifre dell'anno in cui la marcatura CE è stata applicata;
- ◆ Riferimento alla norma di prodotto (EN 14351-1);
- ◆ Descrizione del prodotto: nome generico, materiale, dimensioni, ecc. e impiego previsto;
- ◆ Informazioni sulle caratteristiche essenziali che devono essere dichiarate presentate come:
- ◆ Valori dichiarati o livelli e/o classi;
- ◆ NPD - " Nessuna prestazione determinata" per le caratteristiche quando è pertinente.

## INITIAL TYPE TESTS (ITT)

*The series in this catalogue has been subjected to initial type tests (ITT) for the requirements of product standard UNI EN 14351-1.*

*The results of the initial type tests can be extended to doors and windows of different types and of different sizes and compositions, according to the indications provided for by EN 14351-1 in Appendix A (interdependence between the characteristics and compositions), Appendix E (determination of characteristics) and Appendix F (optional selection of representative samples for the windows).*

*The door and window manufacturer is responsible for verifying compliance of the window with the sample under test. The TWIN Systems consortium makes the results of the test performed available to its customer, after the free usage agreement has been signed.*

### Declaration of Conformity

*The window and door manufacturer must provide the customer with a declaration of conformity which, in accordance with UNI EN 14351-1, must include:*

- ◆ **Name and address of the manufacturer or its authorised representative established in the EEA;**
- ◆ **Description of the product (type, identification, use, etc.) and a copy of the information accompanying the CE marking;**
- ◆ **Provisions with which the product complies (Appendix AZ of product standard UNI EN 14351-1);**
- ◆ **Special conditions applicable to the use of the product (e.g. provisions for use under certain conditions, etc.);**
- ◆ **Name and address of the approved laboratory(ies).**
- ◆ **Name and capacity of the person empowered to sign the declaration on behalf of the manufacturer or his authorised representative.**

*The declaration and certificate must be done in the official language or languages of the Member State where the product is to be used.*

### Labelling and Marking

*The manufacturer must provide sufficient information to ensure the traceability of the product providing the link between the product, the manufacturer and the production. This information must be contained on a label or specified in accompanying documents in the technical specifications published by the manufacturer. The following information must accompany the CE marking symbol:*

- ◆ **Manufacturer's name and registered address or identification mark;**
- ◆ **Last two digits of the year in which the CE marking was applied;**
- ◆ **Reference to the product standard (EN 14351-1);**
- ◆ **Description of the product: generic name, material, size, etc. and intended use;**
- ◆ **Information about the essential characteristics that must be declared;**
- ◆ **Declared values or levels and/or classes;**
- ◆ **NPD - " No Performance Determined" for characteristics when relevant.**



Il simbolo della marcatura CE e le informazioni di accompagnamento devono essere apposti in modo visibile, leggibile e indelebile in una o più delle posizioni seguenti (gerarchia di preferenza del fabbricante):

Qualsiasi parte idonea del prodotto stesso, purché sia assicurata la visibilità quando si aprono le ante; Su un'etichetta attaccata; Sul suo imballaggio; Sul documento commerciale di accompagnamento.

#### DOCUMENTAZIONE TECNICA DI ACCOMPAGNAMENTO

Il fabbricante deve fornire informazioni su quanto segue:

- *Immagazzinaggio e movimentazione, se il fabbricante non è responsabile dell'installazione del prodotto;*
- *Requisiti e tecniche d'installazione (sul posto), se il fabbricante non è responsabile dell'installazione del prodotto (Guida UNCSAAL)*
- *Manutenzione e pulizia (Manuale Consorzio TWIN SYSTEMS)*
- *Istruzioni d'uso finali incluse le istruzioni per la sostituzione di componenti*
- *Istruzioni per l'uso in condizioni di sicurezza.*

In Italia i requisiti obbligatori per la Marcatura CE sono:

- *Permeabilità dell'aria*
- *Trasmittanza termica*
- *Proprietà radiative (Fattore solare g, Trasmissione luminosa (TV))*

In Spagna e in Portogallo i requisiti obbligatori per la Marcatura CE sono:

- *Permeabilità all'aria*
- *Tenuta all'acqua*
- *Resistenza al vento*
- *Trasmittanza termica*
- *Isolamento acustico*

*The CE marking and accompanying information must be affixed in a visible, legible and indelible way in one or more of the following positions (manufacturer's hierarchy of preference):*

***Any suitable part of the product itself, provided that visibility is ensured when opening the doors; On an attached label; On its packaging; On the accompanying commercial document.***

#### ACCOMPANYING TECHNICAL DOCUMENTATION

*The manufacturer will provide information about:*

- *Storage and handling, if the manufacturer is not responsible for the installation of the product*
- *Requirements and installation methods (on site), if the manufacturer is not responsible for the installation of the product (UNCSAAL Guide)*
- *Maintenance and cleaning (TWIN SYSTEMS Consortium Manual)*
- *Final instructions for use including instructions for replacing components; Instructions for safe use.*

***In Italy, the mandatory requirements for CE marking are:***

- *Air permeability*
- *Heat Transmittance*
- *Radiative properties (Solar factor g, Light transmission (TV)).*

***In Spain and Portugal the mandatory requirements for CE marking are :***

- *Air permeability*
- *Watertightnes*
- *Wind resistance*
- *Heat Transmittance*
- *Sound insulation*



## TRASMITTANZA TERMICA DEI SERRAMENTI

## HEAT TRANSMISSION OF WINDOWS

E' necessario sapere che le prescrizioni dettate dal decreto ministeriale cambiano in funzione della tipologia di intervento edilizio (nuova costruzione, ristrutturazione importante di primo oppure secondo livello, riqualificazione energetica) e si applicano ad edifici sia pubblici sia privati.

Per edifici di nuova costruzione si intendono quei fabbricati il cui titolo abilitativo sia stato richiesto dopo l'entrata in vigore del decreto.

Sono assimilati agli edifici di nuova costruzione gli edifici sottoposti a demolizione e ricostruzione, qualunque sia il titolo abilitativo necessario, e gli ampliamenti di edifici esistenti la cui nuova porzione abbia un volume lordo climatizzato superiore al 15% di quello esistente o comunque superiore a 500 m<sup>3</sup>.

Per interventi di ristrutturazione importante di primo livello si intendono quelli che interessano l'involucro edilizio con un'incidenza superiore al 50 per cento della superficie disperdente lorda complessiva dell'edificio, comprendendo anche la ristrutturazione dell'impianto termico per il servizio di climatizzazione invernale e/o estiva asservito all'intero edificio.

Per interventi di ristrutturazione importante di secondo livello si intendono quelli che interessano l'involucro edilizio con un'incidenza superiore al 25 per cento della superficie disperdente lorda complessiva dell'edificio e possono interessare l'impianto termico per il servizio di climatizzazione invernale e/o estiva.

Negli interventi di riqualificazione energetica rientrano gli interventi non riconducibili agli interventi succitati e che hanno un impatto sulla prestazione energetica dell'edificio. Rientrano quindi anche:

- Le ristrutturazioni che interessano l'involucro edilizio con un'incidenza inferiore o uguale al 25% della superficie disperdente lorda complessiva dell'edificio e/o consistono nella nuova installazione, nella ristrutturazione di un impianto termico asservito all'edificio o di altri interventi parziali, ivi compresa la sostituzione del generatore;
- Gli ampliamenti di edifici esistenti la cui nuova porzione abbia un volume lordo climatizzato inferiore o uguale al 15% di quello esistente o comunque inferiore a 500 m<sup>3</sup>.

Per gli edifici di nuova costruzione e per quelli sottoposti a ristrutturazioni di primo livello, non sono previsti specifici limiti di trasmittanza termica da rispettare per le chiusure trasparenti. Sussiste l'obbligo di rispettare limiti per quanto concerne altri parametri tecnici che connotano gli impianti, l'involucro edilizio e l'edificio nel loro complesso (per esempio coefficiente medio globale di scambio termico per trasmissione per unità di superficie disperdente HT' - area solare equivalente estiva per unità di superficie utile Asol,est/Asup utile - indice di prestazione termica utile per riscaldamento EPH,nd - indice di prestazione termica utile per il raffrescamento EPC,nd - indice di prestazione energetica globale dell'edificio EPgl,tot, ecc.) contenuti nell'Allegato A del decreto

*Note that the requirements as of the ministerial decree depend on the type of construction (new construction, major first or second level renovation, energy upgrading) and apply to both public and private buildings.*

*New buildings are those whose building permit has been requested following the promulgation of the decree.*

*Buildings subject to demolition and reconstruction, irrespective of the type of building permit, and extensions to existing buildings whose new portion has a gross air-conditioned volume of more than 15% of the existing one or in any case more than 500 m<sup>3</sup> are considered new buildings.*

*Major first level renovations are those affecting the building shell with an impact of more than 50% of the building's total gross dispersant surface, also including the renovation of the heating system for the winter and/or summer air conditioning service of the entire building.*

*For major second-level renovation interventions, those that concern the building shell with an impact of more than 25 percent of the building's total gross dispersant surface and can regard the heating plant system for the winter and/or summer air conditioning service.*

*Energy upgrading works include activities that are not attributable to the aforementioned activities and that have an impact on the building's energy performance. The following are therefore also included:*

- Renovations that affect the building shell with an impact of less than or equal to 25% of the building's total gross dispersant surface and/or the new installation or upgrading of the building's heating plant or other partial works, including the replacement of the generator;
- Extensions of existing buildings whose new portion has a gross air-conditioned volume of less than or equal to 15% of the existing one or in any case less than 500 m<sup>3</sup>.

*For new buildings and buildings undergoing first level renovations, there are no specific heat transmission limits to be respected for transparent doors. There is an obligation to respect the limits of other technical parameters that characterise the plants, shell and building as a whole (for example, average overall heat exchange coefficient for transmission by dispersant surface unit HT' - equivalent summer solar area per unit of surface area Asol,est/Asup - useful heat performance index for heating EPH,nd - heat performance index for cooling EPC,nd - overall energy performance index of the building EPgl,tot, etc.) contained in Annex A of the decree*



I limiti dell'Allegato A sul coefficiente medio globale di scambio termico per trasmissione per unità di superficie disperdente HT' sono da rispettare anche per gli interventi di ristrutturazione importante di secondo livello.

Nell'ambito degli **interventi di ristrutturazione importante di secondo livello e degli interventi di riqualificazione energetica** sono invece da rispettare i limiti riportati nell'Appendice B del decreto relativamente:

- **Alla trasmittanza termica  $U_w$  dei serramenti** (trasparenti, opachi) e dei **cassonetti** posti a delimitazione di ambienti climatizzati verso l'esterno oppure verso ambienti non climatizzati (cfr. **tabella 1**);
- **Al fattore di trasmissione solare totale  $g_{gl+sh}$  dei serramenti vetriati in combinazione con schermature solari mobili** posizionati sui fronti dell'edificio SUD, EST, OVEST, SUD-EST, SUD-OVEST (cfr. **tabella 2**).

*The limits of Annex A on the overall average coefficient of heat exchange through transmission by unit of dispersant surface HT' must also be respected for major second-level renovations.*

*In the case of major second level renovations and energy upgrading works, the limits set out in Appendix B of the decree must be respected for:*

- **Heat transmission  $U_w$  of the windows (transparent, opaque) and shutter boxes** positioned to delimit air-conditioned environments towards the outside or towards non-conditioned environments (see table 1);
- **The total solar transmission factor  $g_{gl+sh}$  glazed windows in combination with mobile solar shields** positioned on the SOUTH, EAST, WEST, SOUTH-EAST, SOUTH-WEST building façades (see table 2).

### Tabella/Table 1

Valori limite della trasmittanza  $U_w$  dei serramenti (trasparenti, opachi) e dei cassonetti posti a delimitazione di ambienti climatizzati verso l'esterno oppure verso ambienti non climatizzati.

ZONA CLIMATICA	$U_w$ [W/m <sup>2</sup> K]	
	2021	ECOBONUS
<b>Zona A</b>	<b>3.00</b>	<b>2.60</b>
<b>Zona B</b>	<b>3.00</b>	<b>2.60</b>
<b>Zona C</b>	<b>2.00</b>	<b>1.75</b>
<b>Zona D</b>	<b>1.80</b>	<b>1.67</b>
<b>Zona E</b>	<b>1.40</b>	<b>1.30</b>
<b>Zona F</b>	<b>1.00</b>	<b>1.00</b>

### Tabella/Table 2

Valori limite del fattore di trasmissione solare totale  $g_{gl+sh}$  chiusure trasparenti in presenza di schermature solari mobili installate su fronti dell'edificio SUD, EST, OVEST, SUD-EST, SUD-OVEST

ZONA CLIMATICA CLIMATIC ZONE	$g_{gl+sh}$
	2021
<b>Zone TUTTE</b> <b>ALL ZONES</b>	<b>0.35</b>



## VALUTAZIONE DELLA PRESTAZIONE TERMICA DEI SERRAMENTI

### TRASMITTANZA TERMICA:

La trasmittanza termica rappresenta il parametro più significativo per la valutazione del comportamento termico di un prodotto edilizio: minore è il suo valore migliore è la prestazione termica posseduta dal componente stesso. Il calcolo semplificato della trasmittanza termica del componente finestrato  $U_w$  composta da un singolo serramento e relativo vetro (o pannello) si esegue con la formula:

## VALUTAZIONE DELLA PRESTAZIONE TERMICA DEI SERRAMENTI

### HEAT TRANSMISSION:

Heat transmission is the most significant factor in the evaluation of the thermal performance of a building product: the lower its value, the higher the thermal performance of the product.

The simplified heat transmission calculation of the product glazing  $U_w$  comprising a single window and related glass (or panel) the formula is:

$$U_w = \frac{A_g U_g + A_f U_f + l_g \emptyset_g}{A_g + A_f}$$

$A_g$ : Area del vetro in  $m^2$

$U_g$ : Trasmittanza termica riferito all'area centrale della vetrata, e non include l'effetto del distanziatore del vetro lungo il bordo della vetrata stessa

$A_f$ : Area del telaio

$U_f$ : Trasmittanza termica del telaio applicabile in assenza della vetrata

$l_g$ : Lunghezza del perimetro del vetro

$\emptyset$ : Trasmittanza termica lineare concernente la conduzione di calore supplementare che avviene a causa dell'interazione tra telaio, vetri e distanziatore dei vetri in funzione delle proprietà termiche di ognuno di questi componenti e si rileva, secondo quanto precisato nell'allegato E della norma UNI EN ISO 10077-1, preferibilmente con il calcolo numerico eseguito in accordo con la norma ISO 10077-2; quando non sono disponibili i risultati di calcolo dettagliati ci si può riferire ai prospetti E.1 ed E.2 i quali indicano i valori  $\emptyset_g$  di default per le tipiche combinazioni di telai, vetri e distanziatori.

$A_g$ : Area of the glass in  $m^2$

$U_g$ : Heat transmission of the central area of the window, not including the effect of the glass spacer along the edge of the window

$A_f$ : Frame area

$U_f$ : Heat transmission of the frame applicable in absence of the glass

$l_g$ : Length of the perimeter of the glass

$\emptyset$ : Linear heat transmission concerning the additional heat conduction that occurs due to the interaction between the frame, glass and spacer of the glass as a function of the thermal properties of each of these components and it is noted, as specified in Annex E of standard UNI EN ISO 10077-1, preferably with the numerical calculation performed in accordance with ISO 10077-2; when the detailed calculation results are not available you can refer to the default  $\emptyset$  for the typical combinations of frames, glass and spacers.

**ESTENDIBILITÀ**

L'appendice F della norma di prodotto UNI EN 14351-1 suggerisce le tipologie di serramento rappresentative e le relative estensioni, ma essendo la tabella puramente informativa, sta allo stesso produttore scegliere i campioni.

**EXTENSIBILITY**

Appendix F of the product standard UNI EN 14351-1 suggests the types of typical windows and their extensions, but since the table is purely informative, it is up to the manufacturer to choose the samples.

TIPO DI FINESTRA WINDOW TYPE	POSSIBILE ESTENSIONE Possible Extension
<b>Anta FISSA</b> <i>Fixed</i>	<b>Finestra Battente/Ribalta</b> <i>Tilt &amp; Turn Window</i>
<b>Porta Finestra ad Anta Singola (Apertura Interna o Esterna)</b> <i>Single door window (internal or external opening)</i>	
<b>Finestra Anta Singola con Ribalta</b> <i>Single Sash Tilt &amp; Turn Window</i>	
Finestra con DUE o più Porte (Apertura Interna o Esterna) <i>Window with two or more doors (internal or external opening)</i>	<b>Stessa Tipologia</b> <i>Same Type</i>
Finestra a UNA o DUE ante orizzontali scorrevoli <i>Window with ONE or TWO horizontal sliding sashes</i>	
Finestra con DUE Ante Scorrevoli <i>Window with TWO Sliding Sashes</i>	<b>Stessa Tipologia</b> <i>Same Type</i>
Finestra a UNA o DUE ante orizzontali scorrevoli con Ribalta <i>Window with ONE or TWO horizontal sliding sashes with Tilt &amp; Turn</i>	<b>Stessa Tipologia</b> <i>Same Type</i>
Bilico Orizzontale o Verticale <i>Horizontal or vertical pivoting window</i>	<b>Stessa Tipologia</b> <i>Same Type</i>
Finestra a Soffietto <i>Folding Window</i>	<b>Stessa Tipologia</b> <i>Same Type</i>

La norma UNI EN 14351-1 prevede che il calcolo effettuato su di un serramento aventi dimensioni:

1230 (±25%) x 1480 (-25%)  
 1480 (+25%) x 2180 (±25%)

Le analisi termiche effettuate con le misure sopra descritte, possono essere estese a tutti i serramenti di tutte le dimensioni, purché il vetro utilizzato abbia come valore di  $U_g$  uguale o inferiore a  $1.9 \text{ w/m}^2\text{K}$ , altrimenti la norma delle regole di estensione dei valori calcolati sull'infisso normalizzato ad infissi di diverse dimensioni.

Ovviamente i calcoli devono essere effettuati sulle stesse tipologie di infissi, e s'intende che una modifica del componente modifica la caratteristica in questione. In termini di prestazioni termiche è ovvio che andando a togliere o ad aggiungere elementi (per esempio passare da una finestra ad una anta, da una a due e così via), determina un variazione dei valori finali.

The UNI EN 14351-1 standard sets forth the calculation carried out on a window with dimensions:

1230 (±25%) x 1480 (-25%)  
 1480 (+25%) x 2180 (±25%)

The thermal analyses carried out with the measurements described above can be extended to doors and windows of all sizes, provided that the glass used has a  $U_g$  value equal to or less than  $1.9 \text{ w/m}^2\text{K}$ , otherwise the standard of the rules of the values calculated on the normalised frame is extended to frames of different sizes.

Obviously, the calculations must be carried out on the same types of frames, and it is understood that any modification to the component changes the characteristic in question. In terms of thermal performance, it is clear that, removing or adding elements (for example, switching from a window with one door to one with two doors, and so on) results in a change in the final values.



## POSA QUALITÀ

### IL MARCHIO

Il Marchio Posa Qualità Serramenti distinguerà i migliori costruttori italiani di serramenti di tutti i materiali, offrendo ai consumatori italiani uno strumento tangibile per distinguere le migliori aziende con una garanzia assicurativa post vendita sul prodotto installato fino a 10 anni.

In questo modo il costruttore di serramenti potrà qualificare al cliente non solo le prestazioni «astratte» di un serramento, bensì quelle reali, una volta installato, potrà attestare la qualificazione della propria Azienda e potrà garantire nel tempo ciò che ha venduto.

Perché un Marchio rigoroso sulla Posa è l'unica forma di garanzia tangibile da offrire al consumatore.

Il progetto Marchi Posa Qualità prevede un piano di formazione che coinvolgerà tutta la filiera industriale del serramento, un Marchio che certificherà la qualità della progettazione della posa attraverso severi test di laboratorio e un Marchio che garantirà e verificherà la sua corretta esecuzione attraverso controlli a campione.

il consorzio TWIN SYSTEMS è certificato PROGETTAZIONE Posa Qualità Serramenti dal 2020. I suoi consorziati organizzano periodicamente corsi professionali per l'acquisizione dei patentini professionali per i posatori.



## POSA QUALITÀ

### THE TRADEMARK

The Posa Qualità Serramenti Trademark identifies the best Italian manufacturers of windows and doors in all materials, offering Italian consumers a tangible way of identifying the best companies with an after-sales warranty on the installed product of up to 10 years.

In this way, the window manufacturer will be able to offer the customer not only a guaranteed "generic" good performance of the window, but real guarantees and, once installed, it will be able to attest the quality of the company and guarantee the products sold over time.

Because guaranteed good installation is the only way offering customers peace of mind.

The Posa Qualità Brands project includes a training plan that will involve the entire window supply chain, a Brand that will certify the quality of the installation by means of strict laboratory tests and guarantee correct installation through spot checks.

The TWIN SYSTEMS Consortium has been certified Posa Qualità Serramenti DESIGN since 2020. The consortium members organise periodic training courses for installers with the award of professional licenses.

## MANUALE e CATALOGO PRODOTTI TWIN SYSTEMS POSA QUALITÀ



IL MANUALE e CATALOGO PRODOTTI TWIN SYSTEMS per la POSA QUALITÀ è

- Disponibile presso le sedi dei consorziati e dei serramentisti di riferimento
- Liberamente scaricabile sul sito [www.twinsystems.it](http://www.twinsystems.it) nella sezione CATALOGHI

The TWIN SYSTEMS MANUAL and PRODUCT CATALOGUE for POSA QUALITÀ

- Is available from consortium members and reference window and door manufacturers
- Free download from the website [www.twinsystems.it](http://www.twinsystems.it) in the CATALOGUES section

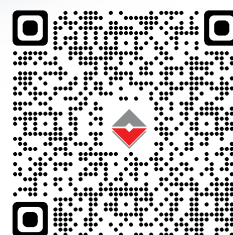

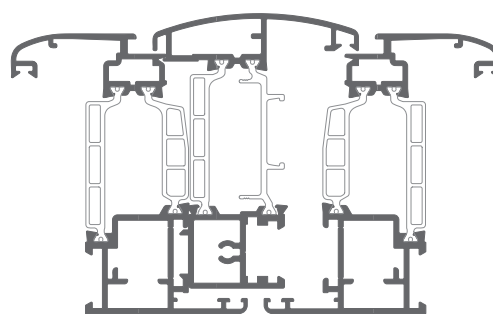
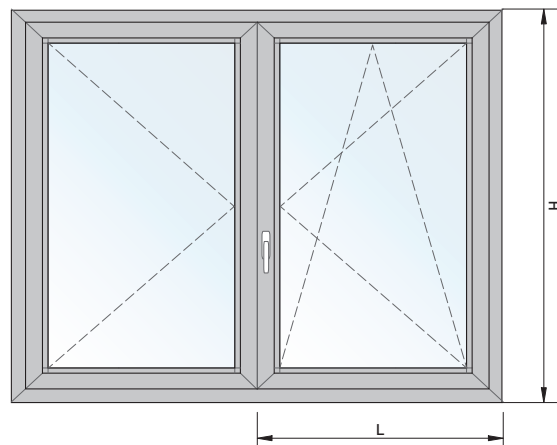
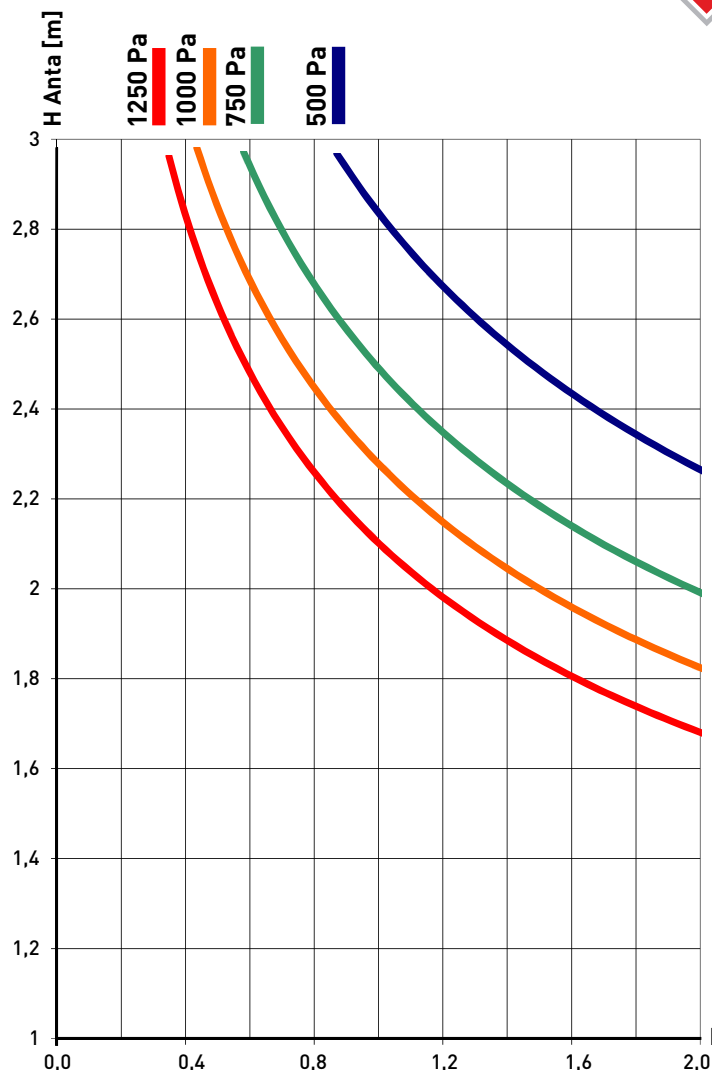

CX75.201 + CX75.301 + CX75.201

Infisso a 2 ante.  
Deflessione del nodo centrale

Il dimensionamento risultante dal grafico è solo indicativo. Il progettista o il serramentista, nel determinare le dimensioni massime dei serramenti, dovrà considerare e valutare, oltre le dimensioni ed il momento d'inerzia dei profilati, anche le caratteristiche applicative e meteorologiche quali l'altezza dal suolo, l'esposizione alla pioggia e la velocità dei venti nella zona.

Per questi dati consigliamo di consultare e seguire le "Raccomandazioni UNCSAAL" elaborate sulla base delle norme UNI, UNI-EN e UNI-CNR esistenti in merito. Verificare che la freccia del profilato sia compatibile con quella del vetro utilizzato.

Le curve rappresentano la larghezza massima dell'anta in funzione della sua altezza e della pressione del vento. Il serramento è considerato a 2 ante uguali. Le curve sono calcolate sulla base della deformazione elastica di 1/300 dell'altezza del serramento.

Double sash windows.  
Deflection of the central node

In determining the maximum dimensions of the doors and windows, in addition to the dimensions and moment of inertia of the profiles, the designer or manufacturer must also consider and evaluate the application and meteorological conditions such as the height from the ground, exposure to rain and the speed of the winds in the area.

For these data, we recommend consulting and following the "UNCSAAL Recommendations" drawn up on the basis of the relative UNI, UNI-EN and UNI-CNR standards. Check that the arrow on the profile is compatible with the arrow on the glass used.

The curves represent the maximum width of the door as a function of its height and wind pressure. The frame is considered to have 2 doors. The curves are calculated on the basis of the elastic deformation of 1/300 of the height of the window.

**ATTENZIONE: Dimensionamento minimo anta L=430 H=750**  
**ATTENTION: Sash Minimum Dimension W=430 H=750**

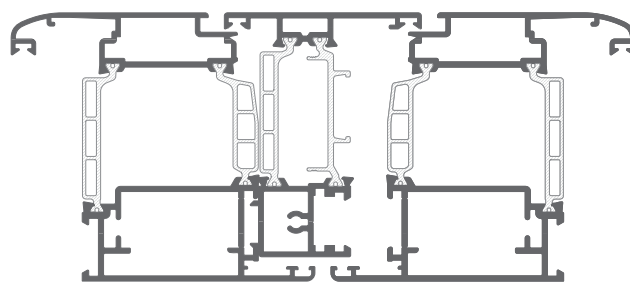
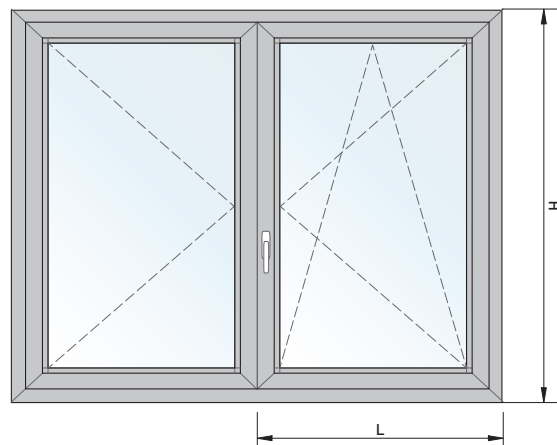
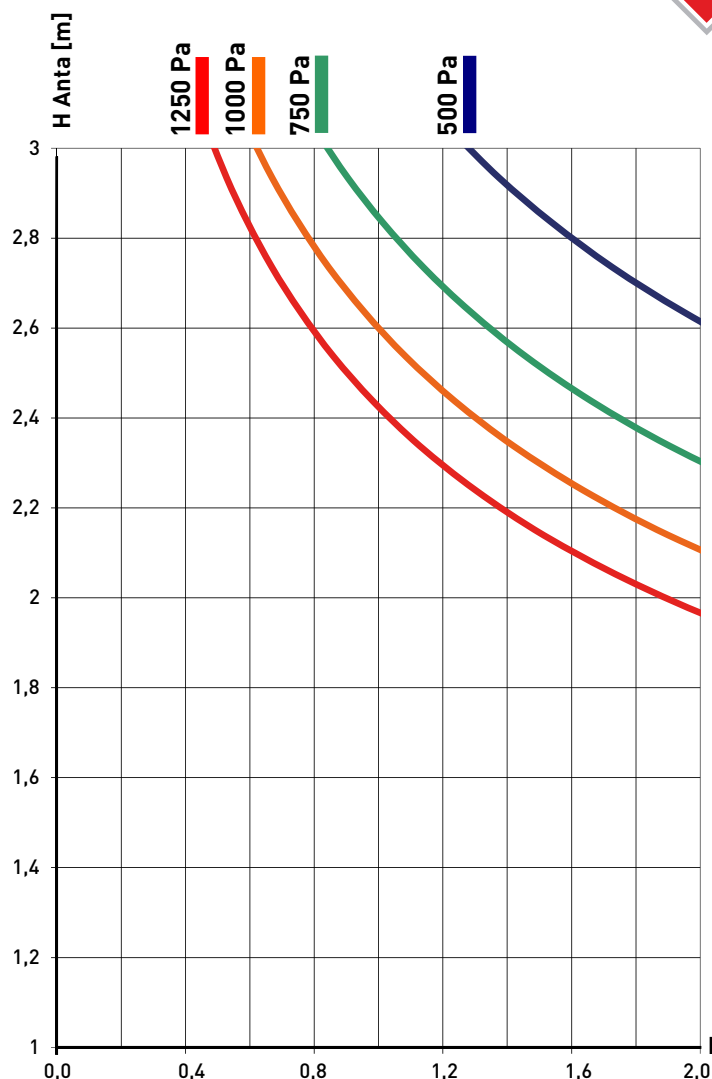

CX75.202 + CX75.301 + CX75.202

Infisso a 2 ante.  
Deflessione del nodo centrale

Il dimensionamento risultante dal grafico è solo indicativo. Il progettista o il serramentista, nel determinare le dimensioni massime dei serramenti, dovrà considerare e valutare, oltre le dimensioni ed il momento d'inerzia dei profilati, anche le caratteristiche applicative e meteorologiche quali l'altezza dal suolo, l'esposizione alla pioggia e la velocità dei venti nella zona.

Per questi dati consigliamo di consultare e seguire le "Raccomandazioni UNCSAAL" elaborate sulla base delle norme UNI, UNI-EN e UNI-CNR esistenti in merito. Verificare che la freccia del profilato sia compatibile con quella del vetro utilizzato.

Le curve rappresentano la larghezza massima dell'anta in funzione della sua altezza e della pressione del vento. Il serramento è considerato a 2 ante uguali. Le curve sono calcolate sulla base della deformazione elastica di 1/300 dell'altezza del serramento.

Double sash windows.  
Deflection of the central node

In determining the maximum dimensions of the doors and windows, in addition to the dimensions and moment of inertia of the profiles, the designer or manufacturer must also consider and evaluate the application and meteorological conditions such as the height from the ground, exposure to rain and the speed of the winds in the area.

For these data, we recommend consulting and following the "UNCSAAL Recommendations" drawn up on the basis of the relative UNI, UNI-EN and UNI-CNR standards. Check that the arrow on the profile is compatible with the arrow on the glass used.

The curves represent the maximum width of the door as a function of its height and wind pressure. The frame is considered to have 2 doors. The curves are calculated on the basis of the elastic deformation of 1/300 of the height of the window.

**ATTENZIONE: Dimensionamento minimo anta L=430 H=750**  
**ATTENTION: Sash Minimum Dimension W=430 H=750**





Profili  
*Profiles*

**Gruppo B**

Elenco Profili  
Profili Scala 1:1

*Profiles List*  
*Profiles Scale 1:1*

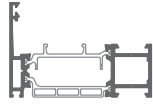
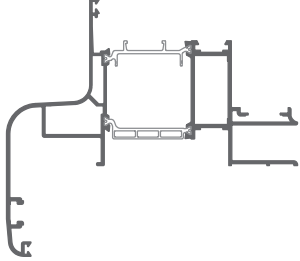
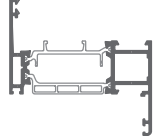
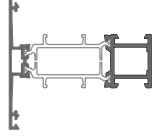
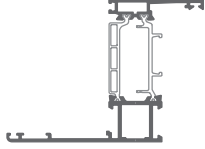
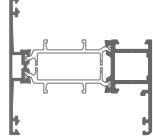
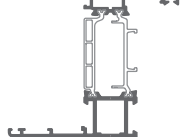
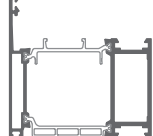
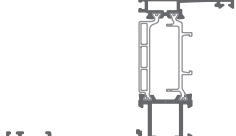
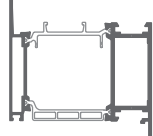
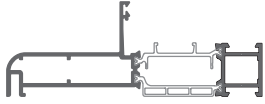
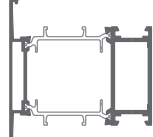
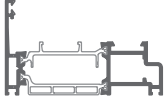
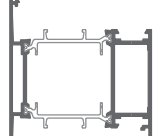
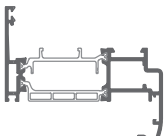

<p><b>CX75.101</b></p> <p>Telaio ad L piccolo   <i>Small L Frame</i></p> <p>Peso Weight kg/ml. <b>1.188</b></p> <p>Jx 31.00 cm4 Wx 7.87 cm3</p> <p>Jy 5.01 cm4 Wy 1.52 cm3</p>		<p>Tavola Table</p> <p>09</p>	<p><b>CX75.109</b></p> <p>Telaio per capannoni   <i>Industrial Sheds Fr.</i></p> <p>Peso Weight kg/ml. <b>2.996</b></p> <p>Jx 235.64 cm4 Wx 27.27 cm3</p> <p>Jy 84.84 cm4 Wy 11.69 cm3</p>		<p>Tavola Table</p> <p>29</p>
<p><b>CX75.102</b></p> <p>Telaio a Z piccolo   <i>Small Z Frame</i></p> <p>Peso Weight kg/ml. <b>1.298</b></p> <p>Jx 36.42 cm4 Wx 9.15 cm3</p> <p>Jy 8.26 cm4 Wy 2.29 cm3</p>		<p>Tavola Table</p> <p>09</p>			
<p><b>CX75.103</b></p> <p>Telaio a T piccolo   <i>Small T Frame</i></p> <p>Peso Weight kg/ml. <b>1.290</b></p> <p>Jx 35.40 cm4 Wx 8.23 cm3</p> <p>Jy 8.36 cm4 Wy 2.32 cm3</p>		<p>Tavola Table</p> <p>09</p>	<p><b>CX75.110</b></p> <p>Tel. Z aletta battuta 54 mm. <i>Glazing bead flap Z-fr. 54 mm.</i></p> <p>Peso Weight kg/ml. <b>1.460</b></p> <p>Jx 42.18 cm4 Wx 9.57 cm3</p> <p>Jy 22.78 cm4 Wy 3,71 cm3</p>		<p>Tavola Table</p> <p>11</p>
<p><b>CX75.104</b></p> <p>Tel. H piccolo-soglia   <i>Low Threshold H Fr.</i></p> <p>Peso Weight kg/ml. <b>1.400</b></p> <p>Jx 42.00 cm4 Wx 10.79 cm3</p> <p>Jy 11.01 cm4 Wy 2.86 cm3</p>		<p>Tavola Table</p> <p>09</p>	<p><b>CX75.111</b></p> <p>Tel. Z aletta battuta 40 mm. <i>Glazing bead flap Z-fr. 40 mm.</i></p> <p>Peso Weight kg/ml. <b>1.389</b></p> <p>Jx 40.04 cm4 Wx 9.42 cm3</p> <p>Jy 14.72 cm4 Wy 2,92 cm3</p>		<p>Tavola Table</p> <p>11</p>
<p><b>CX75.105</b></p> <p>Telaio ad L grande   <i>Big L Frame</i></p> <p>Peso Weight kg/ml. <b>1.664</b></p> <p>Jx 47.38 cm4 Wx 12.49 cm3</p> <p>Jy 19.29 cm4 Wy 4.28 cm3</p>		<p>Tavola Table</p> <p>10</p>	<p><b>CX75.112</b></p> <p>Tel. Z aletta battuta 70 mm. <i>Glazing bead flap Z-fr. 70 mm.</i></p> <p>Peso Weight kg/ml. <b>1.552</b></p> <p>Jx 45.13 cm4 Wx 9.75 cm3</p> <p>Jy 36.69 cm4 Wy 5,04 cm3</p>		<p>Tavola Table</p> <p>11</p>
<p><b>CX75.106</b></p> <p>Telaio a Z grande   <i>Big Z Frame</i></p> <p>Peso Weight kg/ml. <b>1.785</b></p> <p>Jx 52.71 cm4 Wx 13.21 cm3</p> <p>Jy 26.42 cm4 Wy 5.46 cm3</p>		<p>Tavola Table</p> <p>10</p>	<p><b>CX75.116</b></p> <p>Semi-Pilastrino   <i>Semi Pillar</i></p> <p>kg/ml. <b>1.782</b></p> <p>Jx 112.93 cm4 Wx 16.42 cm3</p> <p>Jy 6.49 cm4 Wy 1.89 cm3</p>		<p>Tavola Table</p> <p>13</p>
<p><b>CX75.107</b></p> <p>Telaio a T grande</p> <p>Peso Weight kg/ml. <b>1.775</b></p> <p>Jx 52.30 cm4 Wx 12.91 cm3</p> <p>Jy 26.11 cm4 Wy 5.43 cm3</p>		<p>Tavola Table</p> <p>10</p>	<p><b>CX75.119</b></p> <p>Tel. L complanare piccolo <i>Small coplanar L-frame</i></p> <p>Peso Weight kg/ml. <b>1.249</b></p> <p>Jx 36.99 cm4 Wx 8.43 cm3</p> <p>Jy 5.19 cm4 Wy 1.55 cm3</p>		<p>Tavola Table</p> <p>14</p>
<p><b>CX75.108</b></p> <p>Telaio ad h grande</p> <p>Peso Weight kg/ml. <b>1.896</b></p> <p>Jx 58.60 cm4 Wx 15.56 cm3</p> <p>Jy 32.21 cm4 Wy 6.34 cm3</p>		<p>Tavola Table</p> <p>10</p>	<p><b>CX75.120</b></p> <p>Tel. Z complan. picc. aletta 25 mm <i>Small coplanar Z-frame flap 25 mm</i></p> <p>kg/ml. <b>1.423</b></p> <p>Jx 45.65 cm4 Wx 10.15 cm3</p> <p>Jy 11.16 cm4 Wy 2.93 cm3</p>		<p>Tavola Table</p> <p>14</p>



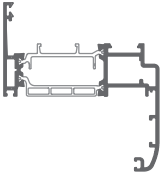
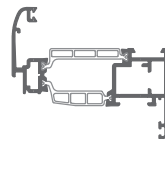
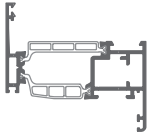
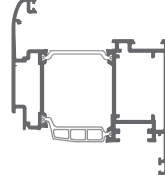
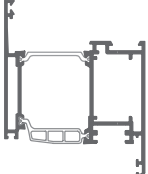
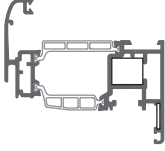
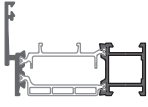
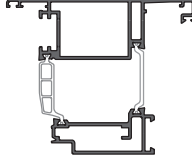
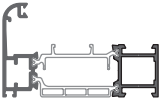
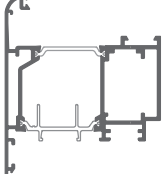
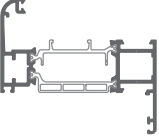
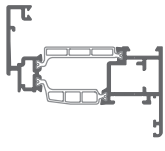
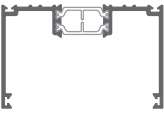
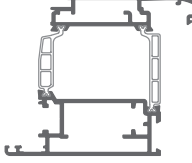
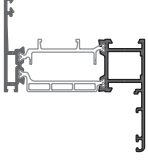
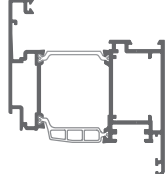

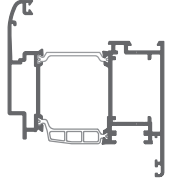
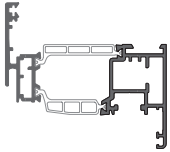
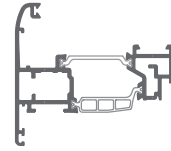
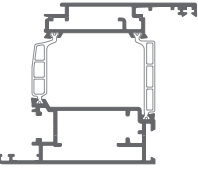
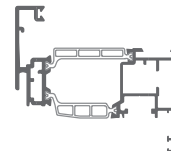
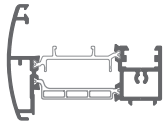
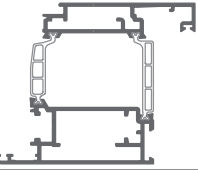
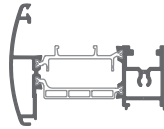
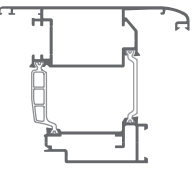
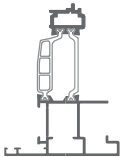
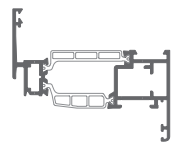
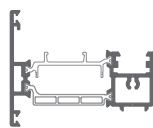
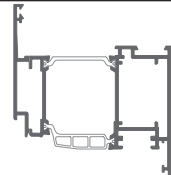
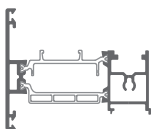
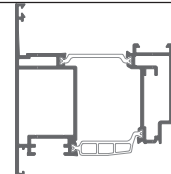
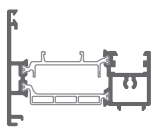

<p><b>CX75.121</b></p> <p>Tel. Z complan. picc. aletta 40 mm <i>Small coplanar Z-frame flap 40 mm</i></p> <p>Peso Weight kg/ml. <b>1.517</b></p> <p>Jx 49.72 cm4 Wx 10.47 cm3 Jy 18.94 cm4 Wy 3.91 cm3</p>		<p>Tavola Table</p> <p>14</p>	<p><b>CX75.201</b></p> <p>Anta tonda piccola c/fermavetro <i>Small round Sash with glazing bead</i></p> <p>Peso Weight kg/ml. <b>1.484</b></p> <p>Jx 45.93 cm4 Wx 10.43 cm3 Jy 9.92 cm4 Wy 2.82 cm3</p>		<p>Tavola Table</p> <p>16</p>
<p><b>CX75.122</b></p> <p>Anta piccola   <i>Small sash</i></p> <p>Peso Weight kg/ml. <b>1.390</b></p> <p>Jx 43.12 cm4 Wx 10.88 cm3 Jy 11.68 cm4 Wy 3.46 cm3</p>		<p>Tavola Table</p> <p>13</p>	<p><b>CX75.202</b></p> <p>Anta tonda grande c/fermavetro <i>Large round Sash with glazing bead</i></p> <p>Peso Weight kg/ml. <b>1.991</b></p> <p>Jx 63.79 cm4 Wx 14.65 cm3 Jy 30.74 cm4 Wy 6.49 cm3</p>		<p>Tavola Table</p> <p>16</p>
<p><b>CX75.123</b></p> <p>Anta grande   <i>Large Sash</i></p> <p>Peso Weight kg/ml. <b>1.884</b></p> <p>Jx 51.50 cm4 Wx 13.08 cm3 Jy 28.12 cm4 Wy 5.78 cm3</p>		<p>Tavola Table</p> <p>14</p>	<p><b>CX75.204</b></p> <p>Anta tonda piccola f/nastro <i>Small round Sash tape hardware</i></p> <p>Peso Weight kg/ml. <b>1.806</b></p> <p>Jx 59.04 cm4 Wx 13.16 cm3 Jy 15.21 cm4 Wy 3.93 cm3</p>		<p>Tavola Table</p> <p>20</p>
<p><b>CX75.124</b></p> <p>Tel. L Piccolo Ridotto   <i>Small L Fr. Reduced</i></p> <p>Peso Weight kg/ml. <b>1.160</b></p> <p>Jx 29.21 cm4 Wx 7.67 cm3 Jy 4.75 cm4 Wy 1.47 cm3</p>		<p>Tavola Table</p> <p>12</p>	<p><b>CX75.205</b></p> <p>Anta apertura esterna <i>External opening Sash</i></p> <p>Peso Weight kg/ml. <b>2.271</b></p> <p>Jx 65.76 cm4 Wx 13.33 cm3 Jy 36.35 cm4 Wy 7.30 cm3</p>		<p>Tavola Table</p> <p>24</p>
<p><b>CX75.152</b></p> <p>Tel. bombato L piccolo   <i>Small Rounded L Fr.</i></p> <p>Peso Weight kg/ml. <b>1.335</b></p> <p>Jx 41.72 cm4 Wx 9.08 cm3 Jy 6.82 cm4 Wy 2.14 cm3</p>		<p>Tavola Table</p> <p>15</p>	<p><b>CX75.207</b></p> <p>Anta apertura bilico <i>Pivoting Sash</i></p> <p>Peso Weight kg/ml. <b>2.116</b></p> <p>Jx 67.02 cm4 Wx 14.41 cm3 Jy 37.29 cm4 Wy 7.32 cm3</p>		<p>Tavola Table</p> <p>17</p>
<p><b>CX75.153</b></p> <p>Tel. bombato Z piccolo   <i>Small Rounded Z Fr.</i></p> <p>Peso Weight kg/ml. <b>1.445</b></p> <p>Jx 49.32 cm4 Wx 11.83 cm3 Jy 10.35 cm4 Wy 2.77 cm3</p>		<p>Tavola Table</p> <p>15</p>	<p><b>CX75.215</b></p> <p>Anta diritta piccola c/fermavetro <i>Small straight Sash w/glazing bead</i></p> <p>Peso Weight kg/ml. <b>1.505</b></p> <p>Jx 47.46 cm4 Wx 10.97 cm3 Jy 10.77 cm4 Wy 03.02 cm3</p>		<p>Tavola Table</p> <p>18</p>
<p><b>XX70.163</b></p> <p>Telaio compensazione   <i>Levelling Frame</i></p> <p>Peso Weight kg/ml. <b>1.214</b></p> <p>Jx 31.02 cm4 Wx 8.16 cm3 Jy 9.24 cm4 Wy 2.44 cm3</p>		<p>Tavola Table</p> <p>32</p>	<p><b>CX75.225</b></p> <p>Anta tonda grande f/nastro <i>Large round Sash tape hardware</i></p> <p>Peso Weight kg/ml. <b>2.382</b></p> <p>Jx 82.84 cm4 Wx 19.03 cm3 Jy 50.34 cm4 Wy 9.46 cm3</p>		<p>Tavola Table</p> <p>21</p>
<p><b>CX75.172</b></p> <p>Telaio a Z aletta battuta 32 mm. <i>Glazing bead flap Z-frame 32 mm.</i></p> <p>Peso Weight kg/ml. <b>1.361</b></p> <p>Jx 38.71 cm4 Wx 9.32 cm3 Jy 11.38 cm4 Wy 2.58 cm3</p>		<p>Tavola Table</p> <p>11</p>	<p><b>CX75.226</b></p> <p>Anta diritta grande c/fermavetro <i>Large straight Sash w/glazing bead</i></p> <p>Peso Weight kg/ml. <b>2.019</b></p> <p>Jx 65.70 cm4 Wx 15.33 cm3 Jy 32.29 cm4 Wy 06.74 cm3</p>		<p>Tavola Table</p> <p>18</p>

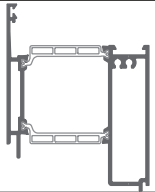
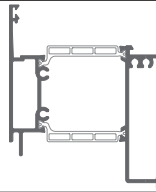
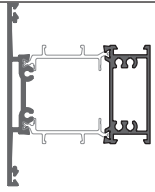
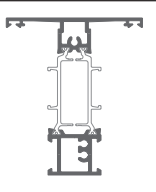
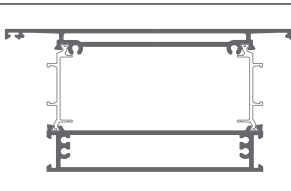
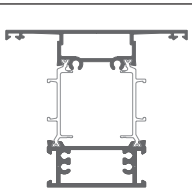
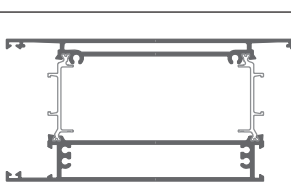
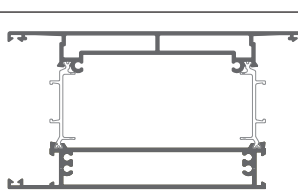
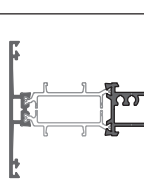
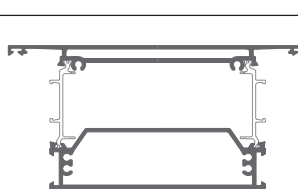
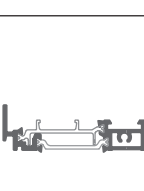
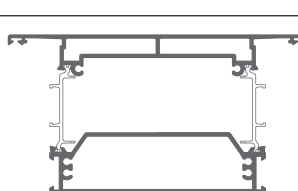
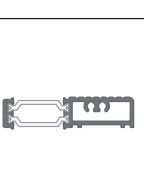

<p><b>CX75.227</b> Anta doppia battuta grande <i>Large double panelled sash</i> Peso Weight kg/ml <b>2.006</b> Jx 64.35 cm<sup>4</sup> Wx 14.87 cm<sup>3</sup> Jy 31.08 cm<sup>4</sup> Wy 6.58 cm<sup>3</sup></p>		<p>Tavola Table <b>19</b></p>	<p><b>CX75.278</b> Anta Piccola Rientro 7mm. f/Nastro <i>Small sash recess 7mm tape hardware</i> Peso Weight kg/ml <b>1.883</b> Jx 58.88 cm<sup>4</sup> Wx 13.01 cm<sup>3</sup> Jy 15.21 cm<sup>4</sup> Wy 3.93 cm<sup>3</sup></p>		<p>Tavola Table <b>39</b></p>
<p><b>CX75.237</b> Anta piccola ap. ext.   Small ext. op. sash Peso Weight kg/ml <b>1.735</b> Jx 49.29 cm<sup>4</sup> Wx 9.84 cm<sup>3</sup> Jy 13.14 cm<sup>4</sup> Wy 3.47 cm<sup>3</sup></p>		<p>Tavola Table <b>21</b></p>	<p><b>CX75.279</b> Anta Grande Rientro 7mm. f/Nastro <i>Large sash recess 7mm tape hardware</i> Peso Weight kg/ml <b>2.392</b> Jx 84.25 cm<sup>4</sup> Wx 19.38 cm<sup>3</sup> Jy 52.43 cm<sup>4</sup> Wy 9.75 cm<sup>3</sup></p>		<p>Tavola Table <b>39</b></p>
<p><b>CX75.238</b> Anta dritta piccola f/nastro <i>Small straight Sash tape hardware</i> Peso Weight kg/ml <b>1.827</b> Jx 60.69 cm<sup>4</sup> Wx 13.72 cm<sup>3</sup> Jy 16.27 cm<sup>4</sup> Wy 4.15 cm<sup>3</sup></p>		<p>Tavola Table <b>21</b></p>	<p><b>CX75.301</b> Riporto tondo   Round wing <b>1.423</b> Peso Weight kg/ml Jx 41.91 cm<sup>4</sup> Wx 9.83 cm<sup>3</sup> Jy 7.72 cm<sup>4</sup> Wy 2.17 cm<sup>3</sup></p>		<p>Tavola Table <b>16</b></p>
<p><b>CX75.262</b> Anta dritta grande f/nastro <i>Large straight Sash tape hardware</i> Peso Weight kg/ml <b>2.404</b> Jx 84.53 cm<sup>4</sup> Wx 19.63 cm<sup>3</sup> Jy 52.43 cm<sup>4</sup> Wy 9.75 cm<sup>3</sup></p>		<p>Tavola Table <b>21</b></p>	<p><b>CX75.302</b> Riporto tondo f/nastro <i>Round wing tape hardware</i> Peso Weight kg/ml <b>1.486</b> Jx 44.94 cm<sup>4</sup> Wx 10.72 cm<sup>3</sup> Jy 8.86 cm<sup>4</sup> Wy 2.41 cm<sup>3</sup></p>		<p>Tavola Table <b>20</b></p>
<p><b>CX75.274</b> Anta tonda grande Ap. Ext. <i>Large round Sash Ext. op.</i> Peso Weight kg/ml <b>2.195</b> Jx 65.12 cm<sup>4</sup> Wx 12.99 cm<sup>3</sup> Jy 36.35 cm<sup>4</sup> Wy 7.30 cm<sup>3</sup></p>		<p>Tavola Table <b>24</b></p>	<p><b>CX75.303</b> Riporto/inversione bilico <i>Wing/reverse pivoting</i> Peso Weight kg/ml <b>1.338</b> Jx 30.59 cm<sup>4</sup> Wx 5.86 cm<sup>3</sup> Jy 7.07 cm<sup>4</sup> Wy 2.17 cm<sup>3</sup></p>		<p>Tavola Table <b>17</b></p>
<p><b>CX75.275</b> Anta dritta rientro 5 mm. <i>Straight Sash recess 5 mm.</i> Peso Weight kg/ml <b>1.468</b> Jx 45.01 cm<sup>4</sup> Wx 9.99 cm<sup>3</sup> Jy 08.56 cm<sup>4</sup> Wy 2.38 cm<sup>3</sup></p>		<p>Tavola Table <b>37</b></p>	<p><b>CX75.304</b> Riporto dritto   Peso Weight kg/ml <b>1.342</b> Jx 36.51 cm<sup>4</sup> Wx 09.17 cm<sup>3</sup> Jy 06.90 cm<sup>4</sup> Wy 01.97 cm<sup>3</sup></p>		<p>Tavola Table <b>16</b></p>
<p><b>CX75.276</b> Anta dritta Grande rientro 5 mm. <i>Large straight Sash recess 5 mm.</i> Peso Weight kg/ml <b>1.981</b> Jx 63.2 cm<sup>4</sup> Wx 14.59 cm<sup>3</sup> Jy 30.74 cm<sup>4</sup> Wy 6.49 cm<sup>3</sup></p>		<p>Tavola Table <b>37</b></p>	<p><b>CX75.308</b> Riporto dritto f/nastro <i>Straight wing Tape Hardware</i> Peso Weight kg/ml <b>1.433</b> Jx 28.71 cm<sup>4</sup> Wx 8.10 cm<sup>3</sup> Jy 8.11 cm<sup>4</sup> Wy 2.25 cm<sup>3</sup></p>		<p>Tavola Table <b>20</b></p>
<p><b>CX75.277</b> Anta Ap. Ext. Grande Rientro 5mm. <i>Large straight Sash Ext. Op. recess 5 mm.</i> Peso Weight kg/ml <b>2.187</b> Jx 65.65 cm<sup>4</sup> Wx 12.99 cm<sup>3</sup> Jy 36.35 cm<sup>4</sup> Wy 7.30 cm<sup>3</sup></p>		<p>Tavola Table <b>38</b></p>	<p><b>CX75.312</b> Riporto Dritto Giunto Aperto <i>Straight wing Open Joint</i> Peso Weight kg/ml <b>1.352</b> Jx 36.50 cm<sup>4</sup> Wx 09.15 cm<sup>3</sup> Jy 06.90 cm<sup>4</sup> Wy 01.97 cm<sup>3</sup></p>		<p>Tavola Table <b>17</b></p>

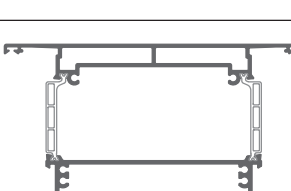



<p><b>CX75.401</b></p> <p>Soprazoccolo   <i>Over Sill</i></p> <p>Peso Weight kg/ml <b>1.923</b></p> <p>Jx 56.09 cm<sup>4</sup> Wx 14.38 cm<sup>3</sup></p> <p>Jy 37.17 cm<sup>4</sup> Wy 7.31 cm<sup>3</sup></p>		<p>Tavola Table</p> <p><b>22</b></p>	<p><b>CX75.428</b></p> <p>Soprazoccolo Anta Rientro 5 mm. <i>Door over sill recess 5 mm.</i></p> <p>Peso Weight kg/ml <b>2.040</b></p> <p>Jx 56.09 cm<sup>4</sup> Wx 14.38 cm<sup>3</sup></p> <p>Jy 39.04 cm<sup>4</sup> Wy 8.87 cm<sup>3</sup></p>		<p>Tavola Table</p> <p><b>37</b></p>
<p><b>CX75.402</b></p> <p>Traverso mm.96   <i>Crosspiece 96 mm.</i></p> <p>Peso Weight kg/ml <b>2.014</b></p> <p>Jx 56.94 cm<sup>4</sup> Wx 14.15 cm<sup>3</sup></p> <p>Jy 27.99 cm<sup>4</sup> Wy 5.81 cm<sup>3</sup></p>		<p>Tavola Table</p> <p><b>22</b></p>	<p><b>CX75.429</b></p> <p>Traverso 72 mm. anta rientro 5 <i>Crosspiece 72 mm. door recess 5</i></p> <p>Peso Weight kg/ml <b>1.524</b></p> <p>Jx 38.26 cm<sup>4</sup> Wx 9.41 cm<sup>3</sup></p> <p>Jy 9.01 cm<sup>4</sup> Wy 2.87 cm<sup>3</sup></p>		<p>Tavola Table</p> <p><b>38</b></p>
<p><b>CX75.403</b></p> <p>Fascia mm. 158   <i>Band 158 mm.</i></p> <p>Peso Weight kg/ml <b>3.086</b></p> <p>Jx 102.75 cm<sup>4</sup> Wx 25.44 cm<sup>3</sup></p> <p>Jy 179.67 cm<sup>4</sup> Wy 22.74 cm<sup>3</sup></p>		<p>Tavola Table</p> <p><b>23</b></p>	<p><b>CX75.430</b></p> <p>Traverso 96 mm. anta rientro 5 <i>Crosspiece 96 mm. door recess 5</i></p> <p>Peso Weight kg/ml <b>2.060</b></p> <p>Jx 56.94 cm<sup>4</sup> Wx 14.15 cm<sup>3</sup></p> <p>Jy 29.02 cm<sup>4</sup> Wy 6.81 cm<sup>3</sup></p>		<p>Tavola Table</p> <p><b>37</b></p>
<p><b>CX75.404</b></p> <p>Zoccolo mm.158   <i>Sill 158 mm.</i></p> <p>Peso Weight kg/ml <b>3.303</b></p> <p>Jx 108.54 cm<sup>4</sup> Wx 27.78 cm<sup>3</sup></p> <p>Jy 198.61 cm<sup>4</sup> Wy 24.40 cm<sup>3</sup></p>		<p>Tavola Table</p> <p><b>23</b></p>	<p><b>CX75.432</b></p> <p>Traverso 158 mm. anta rientro 5 <i>Crosspiece 158 mm. door recess 5</i></p> <p>Peso Weight kg/ml <b>3.401</b></p> <p>Jx 98.54 cm<sup>4</sup> Wx 27.78 cm<sup>3</sup></p> <p>Jy 203.23 cm<sup>4</sup> Wy 27.41 cm<sup>3</sup></p>		<p>Tavola Table</p> <p><b>38</b></p>
<p><b>CX75.408</b></p> <p>Traverso Piccolo mm.72 <i>Small Crosspiece 72 mm.</i></p> <p>Peso Weight kg/ml <b>1.378</b></p> <p>Jx 38.26 cm<sup>4</sup> Wx 9.41 cm<sup>3</sup></p> <p>Jy 8.53 cm<sup>4</sup> Wy 2.34 cm<sup>3</sup></p>		<p>Tavola Table</p> <p><b>25</b></p>	<p><b>CX75.433</b></p> <p>Traverso 158 mm. anta rientro 5 <i>Crosspiece 158 mm. door recess 5</i></p> <p>Peso Weight kg/ml <b>3.254</b></p> <p>Jx 99.94 cm<sup>4</sup> Wx 29.39 cm<sup>3</sup></p> <p>Jy 244.05 cm<sup>4</sup> Wy 30.97 cm<sup>3</sup></p>		<p>Tavola Table</p> <p><b>40</b></p>
<p><b>CX75.409</b></p> <p>Soglia bassa   <i>Low Threshold</i></p> <p>Peso Weight kg/ml <b>1.006</b></p> <p>Jx 20.32 cm<sup>4</sup> Wx 5.15 cm<sup>3</sup></p> <p>Jy 7.08 cm<sup>4</sup> Wy 0.43 cm<sup>3</sup></p>		<p>Tavola Table</p> <p><b>12</b></p>	<p><b>CX75.434</b></p> <p>Traverso 158 mm. anta rientro 5 <i>Crosspiece 158 mm. door recess 5</i></p> <p>Peso Weight kg/ml <b>3.352</b></p> <p>Jx 124.96 cm<sup>4</sup> Wx 28.01 cm<sup>3</sup></p> <p>Jy 254.07 cm<sup>4</sup> Wy 32.12 cm<sup>3</sup></p>		<p>Tavola Table</p> <p><b>40</b></p>
<p><b>CX75.414</b></p> <p>Soglia bassa Porte   <i>Door Low Threshold</i></p> <p>Peso Weight kg/ml <b>0.996</b></p> <p>Jx 0.00 cm<sup>4</sup> Wx 0.00 cm<sup>3</sup></p> <p>Jy 0.00 cm<sup>4</sup> Wy 0.00 cm<sup>3</sup></p>		<p>Tavola Table</p> <p><b>23</b></p>	<p><b>XX70.503</b></p> <p>Coprifilo   <i>Casing Profile</i></p> <p>Peso Weight kg/ml <b>0.224</b></p> <p>Jx 00.00 cm<sup>4</sup> Wx 00.00 cm<sup>3</sup></p> <p>Jy 00.00 cm<sup>4</sup> Wy 00.00 cm<sup>3</sup></p>		<p>Tavola Table</p> <p><b>32</b></p>
<p><b>CX75.415</b></p> <p>Fascia Compl. 78 x 158 mm. <i>Complementary Sash 78 x 158 mm.</i></p> <p>Peso Weight kg/ml <b>3.196</b></p> <p>Jx 124.5 cm<sup>4</sup> Wx 28.65 cm<sup>3</sup></p> <p>Jy 185.49 cm<sup>4</sup> Wy 23.47 cm<sup>3</sup></p>		<p>Tavola Table</p> <p><b>20</b></p>	<p><b>XX70.504</b></p> <p>Coprifilo   <i>Casing Profile</i></p> <p>Peso Weight kg/ml <b>0.238</b></p> <p>Jx 00.00 cm<sup>4</sup> Wx 00.00 cm<sup>3</sup></p> <p>Jy 00.00 cm<sup>4</sup> Wy 00.00 cm<sup>3</sup></p>		<p>Tavola Table</p> <p><b>32</b></p>





<p><b>CX70.521</b></p> <p>Fermavetro Tondo mm.14 <i>Round glazing bead mm. 14</i></p> <p>Peso Weight kg/ml <b>0.266</b></p> <p>Jx 00.00 cm<sup>4</sup> Wx 00.00 cm<sup>3</sup></p> <p>Jy 00.00 cm<sup>4</sup> Wy 00.00 cm<sup>3</sup></p>		Tavola Table <b>33</b>	<p><b>CX70.529</b></p> <p>Fermavetro Dritto mm.26 <i>Straight glazing bead mm. 26</i></p> <p>Peso Weight kg/ml <b>0.362</b></p> <p>Jx 00.00 cm<sup>4</sup> Wx 00.00 cm<sup>3</sup></p> <p>Jy 00.00 cm<sup>4</sup> Wy 00.00 cm<sup>3</sup></p>		Tavola Table <b>34</b>
<p><b>CX70.522</b></p> <p>Fermavetro Tondo mm.18 <i>Round glazing bead mm. 18</i></p> <p>Peso Weight kg/ml <b>0.277</b></p> <p>Jx 00.00 cm<sup>4</sup> Wx 00.00 cm<sup>3</sup></p> <p>Jy 00.00 cm<sup>4</sup> Wy 00.00 cm<sup>3</sup></p>		Tavola Table <b>33</b>	<p><b>CX70.530</b></p> <p>Fermavetro Dritto mm.30 <i>Straight glazing bead mm. 30</i></p> <p>Peso Weight kg/ml <b>0.370</b></p> <p>Jx 00.00 cm<sup>4</sup> Wx 00.00 cm<sup>3</sup></p> <p>Jy 00.00 cm<sup>4</sup> Wy 00.00 cm<sup>3</sup></p>		Tavola Table <b>34</b>
<p><b>CX70.523</b></p> <p>Fermavetro Tondo mm.22 <i>Round glazing bead mm. 22</i></p> <p>Peso Weight kg/ml <b>0.294</b></p> <p>Jx 00.00 cm<sup>4</sup> Wx 00.00 cm<sup>3</sup></p> <p>Jy 00.00 cm<sup>4</sup> Wy 00.00 cm<sup>3</sup></p>		Tavola Table <b>33</b>	<p><b>CX70.531</b></p> <p>Fermavetro Tondo mm.35 <i>Round glazing bead mm. 35</i></p> <p>Peso Weight kg/ml <b>0.370</b></p> <p>Jx 00.00 cm<sup>4</sup> Wx 00.00 cm<sup>3</sup></p> <p>Jy 00.00 cm<sup>4</sup> Wy 00.00 cm<sup>3</sup></p>		Tavola Table <b>33</b>
<p><b>CX70.524</b></p> <p>Fermavetro Tondo mm.26 <i>Round glazing bead mm. 26</i></p> <p>Peso Weight kg/ml <b>0.314</b></p> <p>Jx 00.00 cm<sup>4</sup> Wx 00.00 cm<sup>3</sup></p> <p>Jy 00.00 cm<sup>4</sup> Wy 00.00 cm<sup>3</sup></p>		Tavola Table <b>33</b>	<p><b>CX70.532</b></p> <p>Fermavetro Dritto mm.35 <i>Straight glazing bead mm. 35</i></p> <p>Peso Weight kg/ml <b>0.383</b></p> <p>Jx 00.00 cm<sup>4</sup> Wx 00.00 cm<sup>3</sup></p> <p>Jy 00.00 cm<sup>4</sup> Wy 00.00 cm<sup>3</sup></p>		Tavola Table <b>34</b>
<p><b>CX70.525</b></p> <p>Fermavetro Tondo mm.30 <i>Round glazing bead mm. 30</i></p> <p>Peso Weight kg/ml <b>0.350</b></p> <p>Jx 00.00 cm<sup>4</sup> Wx 00.00 cm<sup>3</sup></p> <p>Jy 00.00 cm<sup>4</sup> Wy 00.00 cm<sup>3</sup></p>		Tavola Table <b>33</b>	<p><b>CX70.533</b></p> <p>Fermavetro Dritto mm.5 <i>Round glazing bead mm. 30</i></p> <p>Peso Weight kg/ml <b>0.252</b></p> <p>Jx 00.00 cm<sup>4</sup> Wx 00.00 cm<sup>3</sup></p> <p>Jy 00.00 cm<sup>4</sup> Wy 00.00 cm<sup>3</sup></p>		Tavola Table <b>34</b>
<p><b>CX70.526</b></p> <p>Fermavetro Dritto mm.14 <i>Straight glazing bead mm. 14</i></p> <p>Peso Weight kg/ml <b>0.279</b></p> <p>Jx 00.00 cm<sup>4</sup> Wx 00.00 cm<sup>3</sup></p> <p>Jy 00.00 cm<sup>4</sup> Wy 00.00 cm<sup>3</sup></p>		Tavola Table <b>34</b>	<p><b>CX70.537</b></p> <p>Fermavetro Dritto mm.40 <i>Straight glazing bead mm. 40</i></p> <p>Peso Weight kg/ml <b>0.403</b></p> <p>Jx 00.00 cm<sup>4</sup> Wx 00.00 cm<sup>3</sup></p> <p>Jy 00.00 cm<sup>4</sup> Wy 00.00 cm<sup>3</sup></p>		Tavola Table <b>34</b>
<p><b>CX70.527</b></p> <p>Fermavetro Dritto mm.18 <i>Straight glazing bead mm. 18</i></p> <p>Peso Weight kg/ml <b>0.290</b></p> <p>Jx 00.00 cm<sup>4</sup> Wx 00.00 cm<sup>3</sup></p> <p>Jy 00.00 cm<sup>4</sup> Wy 00.00 cm<sup>3</sup></p>		Tavola Table <b>34</b>	<p><b>CX70.539</b></p> <p>Fermavetro Dritto mm.44 <i>Straight glazing bead mm. 44</i></p> <p>Peso Weight kg/ml <b>0.324</b></p> <p>Jx 00.00 cm<sup>4</sup> Wx 00.00 cm<sup>3</sup></p> <p>Jy 00.00 cm<sup>4</sup> Wy 00.00 cm<sup>3</sup></p>		Tavola Table <b>34</b>
<p><b>CX70.528</b></p> <p>Fermavetro Dritto mm.22 <i>Straight glazing bead mm. 22</i></p> <p>Peso Weight kg/ml <b>0.307</b></p> <p>Jx 00.00 cm<sup>4</sup> Wx 00.00 cm<sup>3</sup></p> <p>Jy 00.00 cm<sup>4</sup> Wy 00.00 cm<sup>3</sup></p>		Tavola Table <b>34</b>	<p><b>CX70.541</b></p> <p>Fermavetro Dritto mm.44 <i>Straight glazing bead mm. 44</i></p> <p>Peso Weight kg/ml <b>0.418</b></p> <p>Jx 00.00 cm<sup>4</sup> Wx 00.00 cm<sup>3</sup></p> <p>Jy 00.00 cm<sup>4</sup> Wy 00.00 cm<sup>3</sup></p>		Tavola Table <b>34</b>





<b>CX70.562</b>			Tavola Table <b>26</b>
Fermavetro Sicurezza mm.14 <i>Safety glazing bead mm. 14</i>			
Peso Weight	kg/ml <b>0.330</b>		
Jx 00.00 cm <sup>4</sup>	Wx 00.00 cm <sup>3</sup>		
Jy 00.00 cm <sup>4</sup>	Wy 00.00 cm <sup>3</sup>		

<b>CX70.572</b>			Tavola Table <b>35</b>
Fermavetro Clips Tondo mm.18 <i>Round glazing bead Clips mm. 18</i>			
Peso Weight	kg/ml <b>0.262</b>		
Jx 00.00 cm <sup>4</sup>	Wx 0.00 cm <sup>3</sup>		
Jy 00.00 cm <sup>4</sup>	Wy 0.00 cm <sup>3</sup>		

<b>CX70.563</b>			Tavola Table <b>36</b>
Fermavetro Sicurezza mm.18 <i>Safety glazing bead mm. 18</i>			
Peso Weight	kg/ml <b>0.348</b>		
Jx 00.00 cm <sup>4</sup>	Wx 00.00 cm <sup>3</sup>		
Jy 00.00 cm <sup>4</sup>	Wy 00.00 cm <sup>3</sup>		

<b>CX70.573</b>			Tavola Table <b>35</b>
Fermavetro Clips Tondo mm.22 <i>Round glazing bead Clips mm. 22</i>			
Peso Weight	kg/ml <b>0.283</b>		
Jx 00.00 cm <sup>4</sup>	Wx 0.00 cm <sup>3</sup>		
Jy 00.00 cm <sup>4</sup>	Wy 0.00 cm <sup>3</sup>		

<b>CX70.564</b>			Tavola Table <b>36</b>
Fermavetro Sicurezza mm.22 <i>Safety glazing bead mm. 22</i>			
Peso Weight	kg/ml <b>0.372</b>		
Jx 00.00 cm <sup>4</sup>	Wx 00.00 cm <sup>3</sup>		
Jy 00.00 cm <sup>4</sup>	Wy 00.00 cm <sup>3</sup>		

<b>CX70.574</b>			Tavola Table <b>35</b>
Fermavetro Clips Tondo mm.26 <i>Round glazing bead Clips mm. 26</i>			
Peso Weight	kg/ml <b>0.313</b>		
Jx 00.00 cm <sup>4</sup>	Wx 0.00 cm <sup>3</sup>		
Jy 00.00 cm <sup>4</sup>	Wy 0.00 cm <sup>3</sup>		

<b>CX70.565</b>			Tavola Table <b>36</b>
Fermavetro Sicurezza mm.26 <i>Safety glazing bead mm. 26</i>			
Peso Weight	kg/ml <b>0.294</b>		
Jx 00.00 cm <sup>4</sup>	Wx 00.00 cm <sup>3</sup>		
Jy 00.00 cm <sup>4</sup>	Wy 00.00 cm <sup>3</sup>		

<b>CX70.575</b>			Tavola Table <b>35</b>
Fermavetro Clips Tondo mm.30 <i>Round glazing bead Clips mm. 30</i>			
Peso Weight	kg/ml <b>0.340</b>		
Jx 00.00 cm <sup>4</sup>	Wx 0.00 cm <sup>3</sup>		
Jy 00.00 cm <sup>4</sup>	Wy 0.00 cm <sup>3</sup>		

<b>CX70.566</b>			Tavola Table <b>36</b>
Fermavetro Sicurezza mm.30 <i>Safety glazing bead mm. 30</i>			
Peso Weight	kg/ml <b>0.314</b>		
Jx 00.00 cm <sup>4</sup>	Wx 00.00 cm <sup>3</sup>		
Jy 00.00 cm <sup>4</sup>	Wy 00.00 cm <sup>3</sup>		

<b>CX70.581</b>			Tavola Table <b>35</b>
Fermavetro Clips Tondo mm.35 <i>Round glazing bead Clips mm. 35</i>			
Peso Weight	kg/ml <b>0.361</b>		
Jx 00.00 cm <sup>4</sup>	Wx 0.00 cm <sup>3</sup>		
Jy 00.00 cm <sup>4</sup>	Wy 0.00 cm <sup>3</sup>		

<b>CX70.567</b>			Tavola Table <b>36</b>
Fermavetro Sicurezza mm.35 <i>Safety glazing bead mm. 30</i>			
Peso Weight	kg/ml <b>0.434</b>		
Jx 00.00 cm <sup>4</sup>	Wx 0.00 cm <sup>3</sup>		
Jy 00.00 cm <sup>4</sup>	Wy 0.00 cm <sup>3</sup>		

<b>XX70.601</b>			Tavola Table <b>22</b>
Gocciolatoio   Drip Tray			
Peso Weight	kg/ml <b>0.269</b>		
Jx 00.00 cm <sup>4</sup>	Wx 0.00 cm <sup>3</sup>		
Jy 00.00 cm <sup>4</sup>	Wy 0.00 cm <sup>3</sup>		

<b>CX70.568</b>			Tavola Table <b>36</b>
Fermavetro Sicurezza mm.10 <i>Safety glazing bead mm. 10</i>			
Peso Weight	kg/ml <b>0.297</b>		
Jx 00.00 cm <sup>4</sup>	Wx 0.00 cm <sup>3</sup>		
Jy 00.00 cm <sup>4</sup>	Wy 0.00 cm <sup>3</sup>		

<b>XX70.603</b>			Tavola Table <b>22</b>
Soglia Piana   Flat Threshold			
Peso Weight	kg/ml <b>0.275</b>		
Jx 00.00 cm <sup>4</sup>	Wx 0.00 cm <sup>3</sup>		
Jy 00.00 cm <sup>4</sup>	Wy 0.00 cm <sup>3</sup>		

<b>CX70.571</b>			Tavola Table <b>35</b>
Fermavetro Clips Tondo mm.14 <i>Round glazing bead Clips mm. 14</i>			
Peso Weight	kg/ml <b>0.216</b>		
Jx 00.00 cm <sup>4</sup>	Wx 0.00 cm <sup>3</sup>		
Jy 00.00 cm <sup>4</sup>	Wy 0.00 cm <sup>3</sup>		

<b>CX75.604</b>			Tavola Table <b>25</b>
Inversione di Battuta   Rabbet Reversal			
Peso Weight	kg/ml <b>1.212</b>		
Jx 00.00 cm <sup>4</sup>	Wx 0.00 cm <sup>3</sup>		
Jy 00.00 cm <sup>4</sup>	Wy 0.00 cm <sup>3</sup>		



<p><b>CX70.605</b></p> <p>Astina   Bar</p> <p>Peso Weight kg/ml 0.146</p> <p>Jx 00.00 cm<sup>4</sup> Wx 0.00 cm<sup>3</sup></p> <p>Jy 00.00 cm<sup>4</sup> Wy 0.00 cm<sup>3</sup></p>		Tavola Table 18	<p><b>XX70.635</b></p> <p>Battuta riportata per telaio   Added rabbet for frame</p> <p>Peso Weight kg/ml 0.306</p> <p>Jx 00.00 cm<sup>4</sup> Wx 0.00 cm<sup>3</sup></p> <p>Jy 00.00 cm<sup>4</sup> Wy 0.00 cm<sup>3</sup></p>		Tavola Table 12
<p><b>XX70.606</b></p> <p>Scivolo Esterno Soglia Bassa Bottom threshold external slide</p> <p>Peso Weight kg/ml 0.322</p> <p>Jx 00.00 cm<sup>4</sup> Wx 0.00 cm<sup>3</sup></p> <p>Jy 00.00 cm<sup>4</sup> Wy 0.00 cm<sup>3</sup></p>		Tavola Table 12	<p><b>XX70.636</b></p> <p>Doga Stave profile</p> <p>Peso Weight kg/ml 1.644</p> <p>Jx 00.00 cm<sup>4</sup> Wx 0.00 cm<sup>3</sup></p> <p>Jy 00.00 cm<sup>4</sup> Wy 0.00 cm<sup>3</sup></p>		Tavola Table 25
<p><b>MX603.607</b></p> <p>Scivolo Interno Soglia Bassa Bottom threshold Internal slide</p> <p>Peso Weight kg/ml 0.149</p> <p>Jx 00.00 cm<sup>4</sup> Wx 0.00 cm<sup>3</sup></p> <p>Jy 00.00 cm<sup>4</sup> Wy 0.00 cm<sup>3</sup></p>		Tavola Table 12	<p><b>CX75.640</b></p> <p>Profilo Sostegno Inversione Support Profile Reversal</p> <p>Peso Weight kg/ml 0.000</p> <p>Jx 00.00 cm<sup>4</sup> Wx 0.00 cm<sup>3</sup></p> <p>Jy 00.00 cm<sup>4</sup> Wy 0.00 cm<sup>3</sup></p>		Tavola Table 25
<p><b>RX70.609</b></p> <p>Chiusura Rinforzo Montanti Uprights reinforcement closure depth</p> <p>Peso Weight kg/ml 0.393</p> <p>Jx 00.00 cm<sup>4</sup> Wx 0.00 cm<sup>3</sup></p> <p>Jy 00.00 cm<sup>4</sup> Wy 0.00 cm<sup>3</sup></p>		Tavola Table 13	<p><b>XX70.643</b></p> <p>Porta Spazzolino Anta Sash Brush Holder</p> <p>Peso Weight kg/ml 0.264</p> <p>Jx 00.00 cm<sup>4</sup> Wx 00.00 cm<sup>3</sup></p> <p>Jy 00.00 cm<sup>4</sup> Wy 00.00 cm<sup>3</sup></p>		Tavola Table 13
<p><b>XX70.611</b></p> <p>Profilo per squadretta   Corner Joint Profile</p> <p>Peso Weight kg/ml 3.426</p> <p>Jx 00.00 cm<sup>4</sup> Wx 0.00 cm<sup>3</sup></p> <p>Jy 00.00 cm<sup>4</sup> Wy 0.00 cm<sup>3</sup></p>		Tavola Table 20	<p><b>XX70.648</b></p> <p>Profilo di battuta Capannoni Shed profile</p> <p>Peso Weight kg/ml 0.801</p> <p>Jx 00.00 cm<sup>4</sup> Wx 00.00 cm<sup>3</sup></p> <p>Jy 00.00 cm<sup>4</sup> Wy 00.00 cm<sup>3</sup></p>		Tavola Table ---
<p><b>XX70.612</b></p> <p>Profilo bancalino   Pallet Profile</p> <p>Peso Weight kg/ml 0.254</p> <p>Jx 00.00 cm<sup>4</sup> Wx 0.00 cm<sup>3</sup></p> <p>Jy 00.00 cm<sup>4</sup> Wy 0.00 cm<sup>3</sup></p>		Tavola Table 12	<p><b>CX75.701</b></p> <p>Spalla laterale chiusa   Closed Side Reveal</p> <p>Peso Weight kg/ml 3.073</p> <p>Jx 288.00 cm<sup>4</sup> Wx 37.62 cm<sup>3</sup></p> <p>Jy 129.18 cm<sup>4</sup> Wy 19.16 cm<sup>3</sup></p>		Tavola Table 26
<p><b>XX75.613</b></p> <p>Angolo universale  </p> <p>Peso Weight kg/ml 1.963</p> <p>Jx 00.00 cm<sup>4</sup> Wx 0.00 cm<sup>3</sup></p> <p>Jy 00.00 cm<sup>4</sup> Wy 0.00 cm<sup>3</sup></p>		Tavola Table 32	<p><b>CX75.702</b></p> <p>Spalla laterale aperta   Open Side Reveal</p> <p>Peso Weight kg/ml 2.335</p> <p>Jx 240.97 cm<sup>4</sup> Wx 30.45 cm<sup>3</sup></p> <p>Jy 87.13 cm<sup>4</sup> Wy 10.95 cm<sup>3</sup></p>		Tavola Table 26
<p><b>CX75.627</b></p> <p>Battuta riportata per zoccolo Added rabbet for sill</p> <p>Peso Weight kg/ml 0.659</p> <p>Jx 16.43 cm<sup>4</sup> Wx 3.87 cm<sup>3</sup></p> <p>Jy 07.16 cm<sup>4</sup> Wy 3.94 cm<sup>3</sup></p>		Tavola Table 23			





<b>XX70.703</b>		
Traverso Superiore Monoblocco <i>Upper Monobloc Crosspiece</i>		Tavola Table <b>27</b>
Peso Weight kg/ml <b>0.791</b>		
Jx 00.00 cm <sup>4</sup> Wx 0.00 cm <sup>3</sup>		
Jy 00.00 cm <sup>4</sup> Wy 0.00 cm <sup>3</sup>		

<b>XX70.808</b>		
Jolly per Imbotte   <i>Jolly for Jambs</i>		Tavola Table <b>30</b>
Peso Weight kg/ml <b>0.750</b>		
Jx 00.00 cm <sup>4</sup> Wx 0.00 cm <sup>3</sup>		
Jy 00.00 cm <sup>4</sup> Wy 0.00 cm <sup>3</sup>		

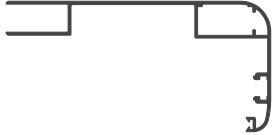
<b>XX70.704</b>		
Coprivite   <i>Screw Cover</i>		Tavola Table <b>27</b>
Peso Weight kg/ml <b>0.135</b>		
Jx 00.00 cm <sup>4</sup> Wx 0.00 cm <sup>3</sup>		
Jy 00.00 cm <sup>4</sup> Wy 0.00 cm <sup>3</sup>		

<b>XX70.809</b>		
Imbotte mm.140   <i>Jamb 140 mm.</i>		Tavola Table <b>30</b>
Peso Weight kg/ml <b>1.580</b>		
Jx 00.00 cm <sup>4</sup> Wx 0.00 cm <sup>3</sup>		
Jy 00.00 cm <sup>4</sup> Wy 0.00 cm <sup>3</sup>		

<b>XX70.705</b>		
Profilo battuta cassonetto <i>Shutter box rabbet profile</i>		Tavola Table <b>27</b>
Peso Weight kg/ml <b>0.155</b>		
Jx 00.00 cm <sup>4</sup> Wx 0.00 cm <sup>3</sup>		
Jy 00.00 cm <sup>4</sup> Wy 0.00 cm <sup>3</sup>		

<b>CX45.3362</b>		
Centrale per Cassonetto   <i>Central Shutter Box</i>		Tavola Table <b>28</b>
Peso Weight kg/ml <b>1.150</b>		
Jx 288.00 cm <sup>4</sup> Wx 37.62 cm <sup>3</sup>		
Jy 129.18 cm <sup>4</sup> Wy 19.16 cm <sup>3</sup>		

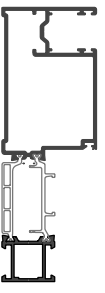
<b>CX75.706</b>		
Mezza spalla monoblocco <i>Monobloc Half Reveal</i>		Tavola Table <b>27</b>
Peso Weight kg/ml <b>2.098</b>		
Jx 163.53 cm <sup>4</sup> Wx 20.23 cm <sup>3</sup>		
Jy 18.60 cm <sup>4</sup> Wy 6.48 cm <sup>3</sup>		

<b>CX45.3363</b>		
Super./Infer. Cassonetto <i>Upper/Lower Shutter Box</i>		Tavola Table <b>28</b>
Peso Weight kg/ml <b>1.379</b>		
Jx 288.00 cm <sup>4</sup> Wx 37.62 cm <sup>3</sup>		
Jy 129.18 cm <sup>4</sup> Wy 19.16 cm <sup>3</sup>		

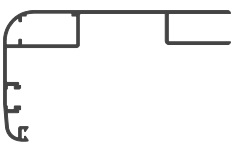
<b>XX70.801</b>		
Imbotte da mm.120   <i>Jamb 120 mm.</i>		Tavola Table <b>30</b>
Peso Weight kg/ml <b>1.317</b>		
Jx 76.93 cm <sup>4</sup> Wx 9.91 cm <sup>3</sup>		
Jy 20.54 cm <sup>4</sup> Wy 4.10 cm <sup>3</sup>		

<b>XX70.802</b>		
Prolunga Imbotte 90 mm. <i>90 mm. Jamb Extension</i>		Tavola Table <b>30</b>
Peso Weight kg/ml <b>0.882</b>		
Jx 00.00 cm <sup>4</sup> Wx 0.00 cm <sup>3</sup>		
Jy 00.00 cm <sup>4</sup> Wy 0.00 cm <sup>3</sup>		

<b>XX70.2040</b>		
Gocciolatoio Mini   <i>Mini Drip Tray</i>		Tavola Table <b>18</b>
Peso Weight kg/ml <b>0.095</b>		
Jx 00.00 cm <sup>4</sup> Wx 0.00 cm <sup>3</sup>		
Jy 00.00 cm <sup>4</sup> Wy 0.00 cm <sup>3</sup>		

<b>XX70.803</b>		
Prolunga Imbotte 50 mm. <i>50 mm. Jamb Extension</i>		Tavola Table <b>30</b>
Peso Weight kg/ml <b>0.574</b>		
Jx 00.00 cm <sup>4</sup> Wx 0.00 cm <sup>3</sup>		
Jy 00.00 cm <sup>4</sup> Wy 0.00 cm <sup>3</sup>		

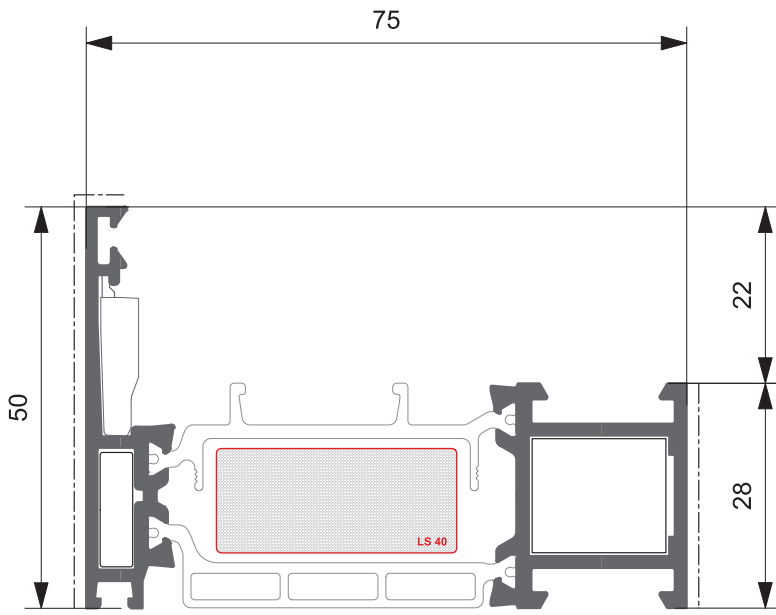

**CX75.101**

Kg/ml 1.175  
--- mm. 78,0

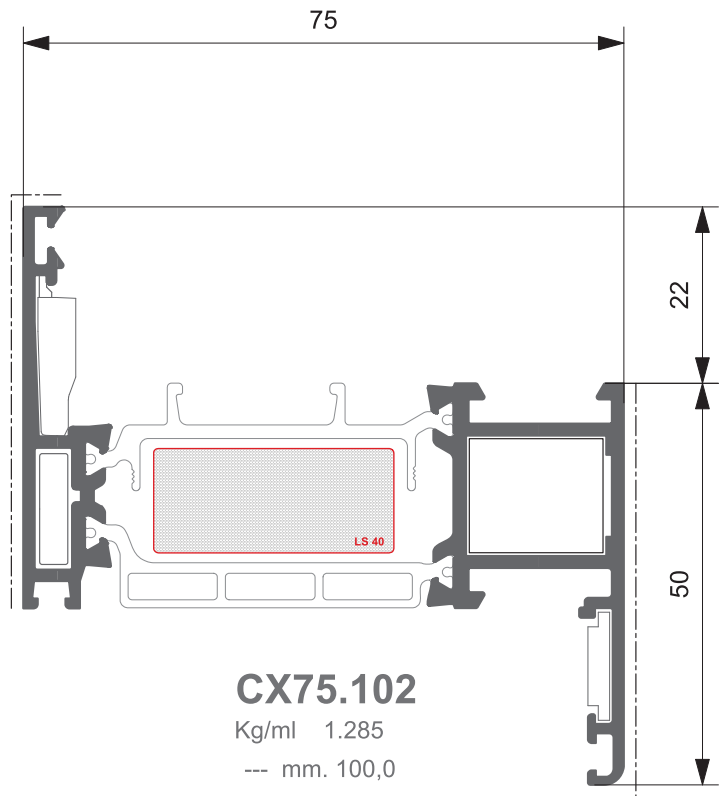

**CX75.102**

Kg/ml 1.285  
--- mm. 100,0

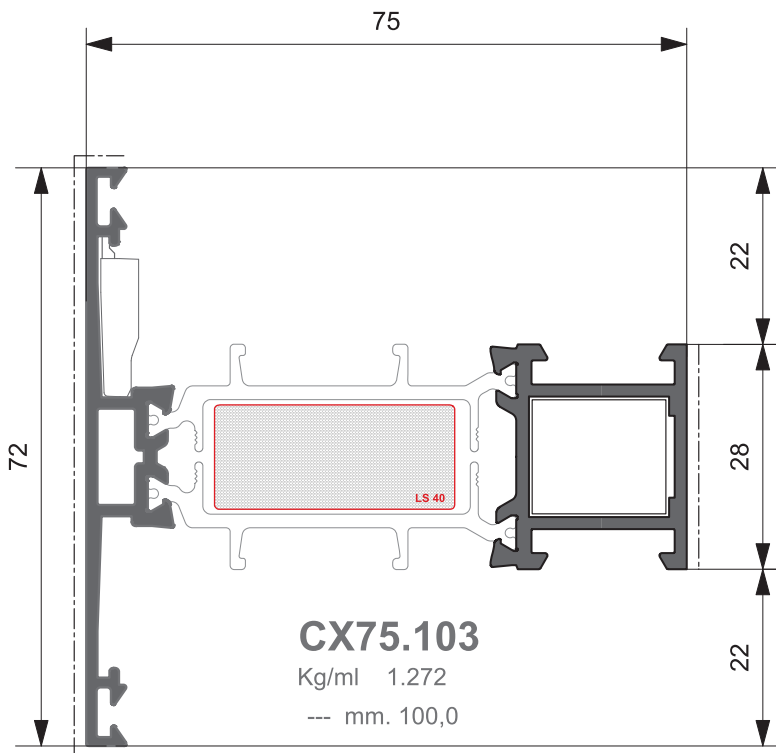

**CX75.103**

Kg/ml 1.272  
--- mm. 100,0

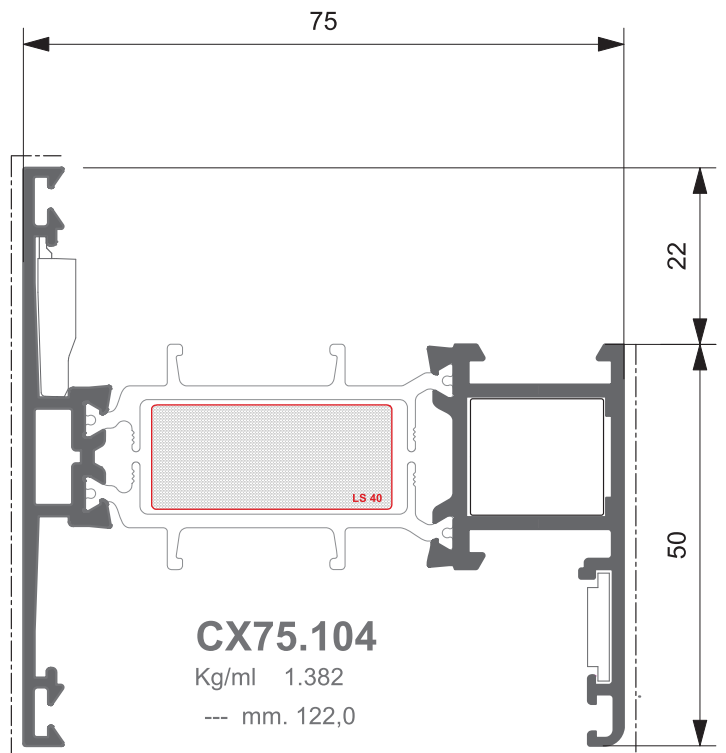

**CX75.104**

Kg/ml 1.382  
--- mm. 122,0

Profilato Profile	Squadretta esterna   External Corner Joint		Squadretta Interna   Internal Corner Joint				Sq. Allineamento   Alining Corner J.	
	Cianfrinare Riveting	Spinare Crimping	Bottone Slot	Cianfrinare Riveting	Spinare Crimping	Avvitare Screw	Esterna External	Interna Internal
CX75.101	ARX.03.SQ	ARX.03.SQ + ARX.08.SQ	AWX.16.SQ		AWX.19.SQ		ARX.15.SQ	
CX75.102	ARX.03.SQ	ARX.03.SQ + ARX.08.SQ	AWX.16.SQ		AWX.19.SQ		ARX.15.SQ	ARX.10.SQ
CX75.102			AWX.16.SQ		AWX.19.SQ		ARX.15.SQ	
CX75.102			AWX.16.SQ		AWX.19.SQ		ARX.15.SQ	ARX.10.SQ

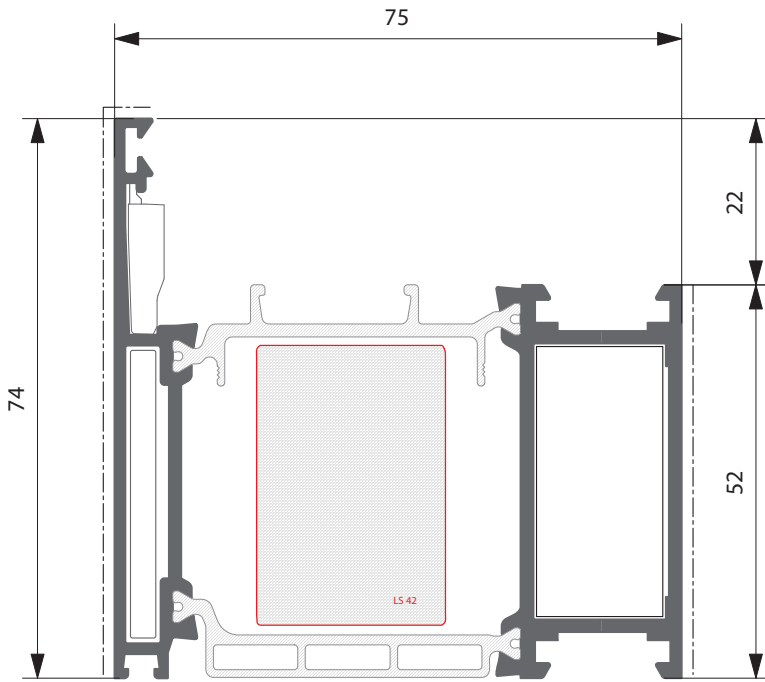

**CX75.105**

Kg/ml 1.650  
--- mm. 126,0

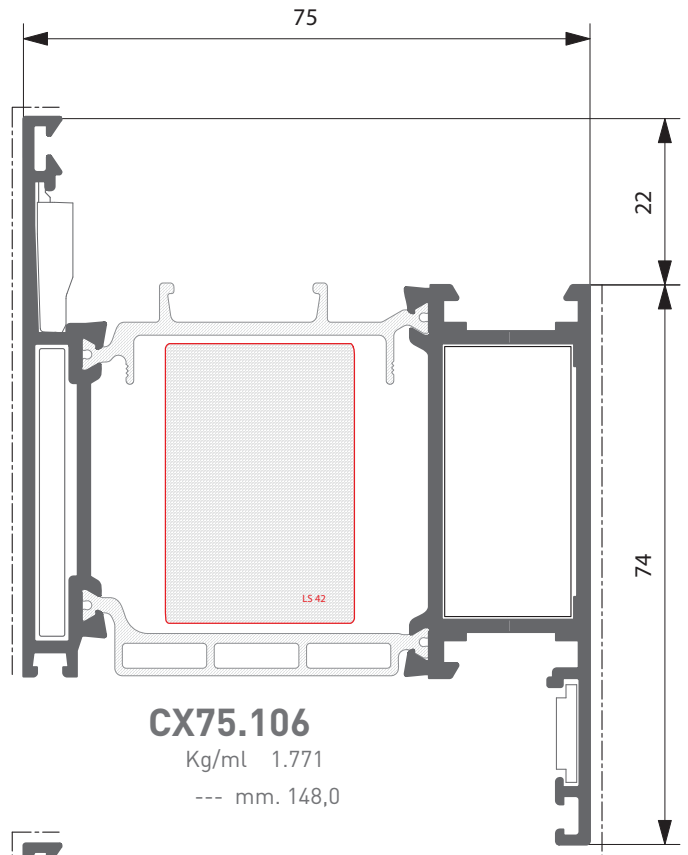

**CX75.106**

Kg/ml 1.771  
--- mm. 148,0

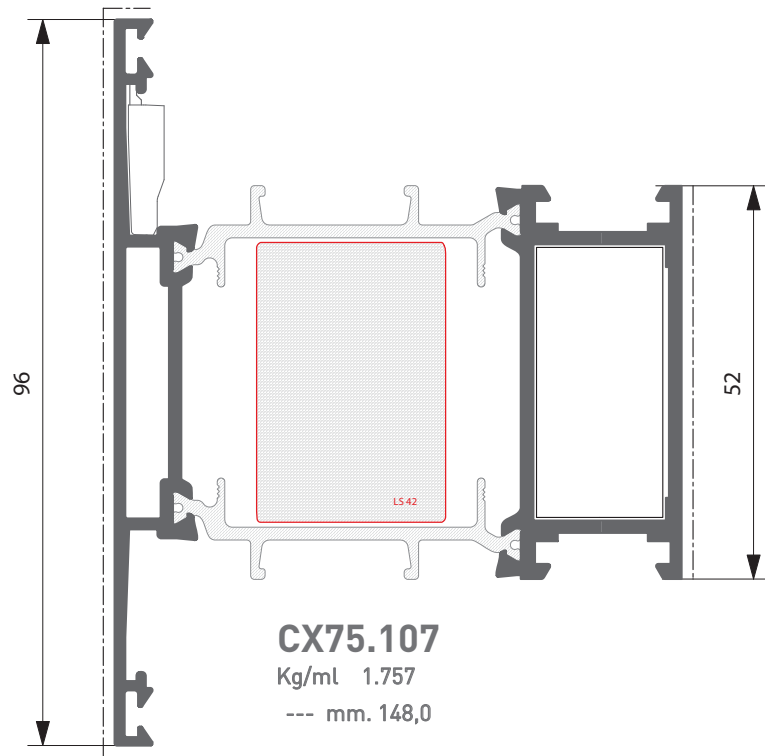

**CX75.107**

Kg/ml 1.757  
--- mm. 148,0

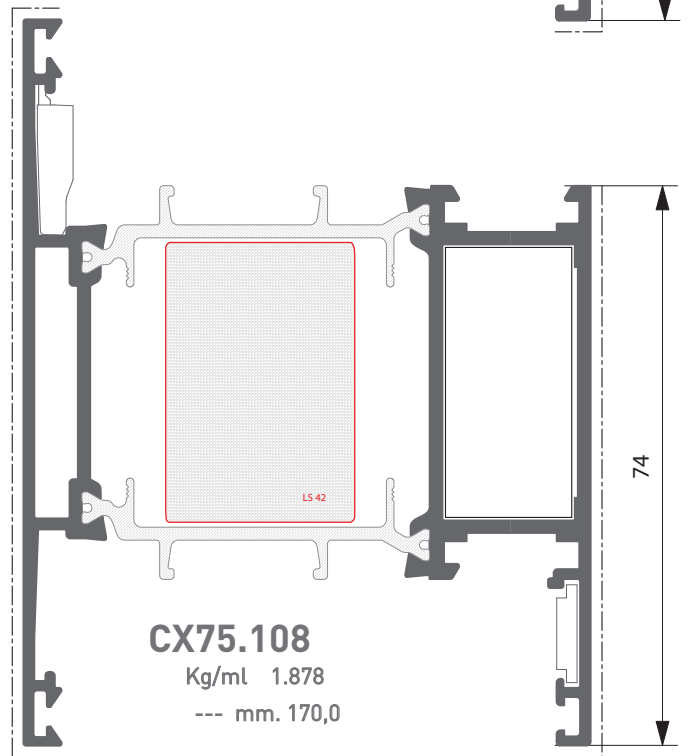

**CX75.108**

Kg/ml 1.878  
--- mm. 170,0

Profilato Profile	Squadretta esterna   External Corner Joint			Squadretta Interna   Internal Corner Joint					Sq. Allineamento   Alining Corner J.	
	Cianfrinare Riveting	Spinare Crimping		Bottone Slot	Cianfrinare Riveting	Spinare Crimping	Avvitare Screw	Esterna External	Interna Internal	
CX75.105	ARX.06.SQ	ARX.06.SQ + ARX.08.SQ				AWX.17.SQ		ARX.15.SQ		
CX75.106	ARX.06.SQ	ARX.06.SQ + ARX.08.SQ				AWX.17.SQ		ARX.15.SQ	ARX.10.SQ	
CX75.107						AWX.17.SQ		ARX.15.SQ		
CX75.108						AWX.17.SQ		ARX.15.SQ	ARX.10.SQ	

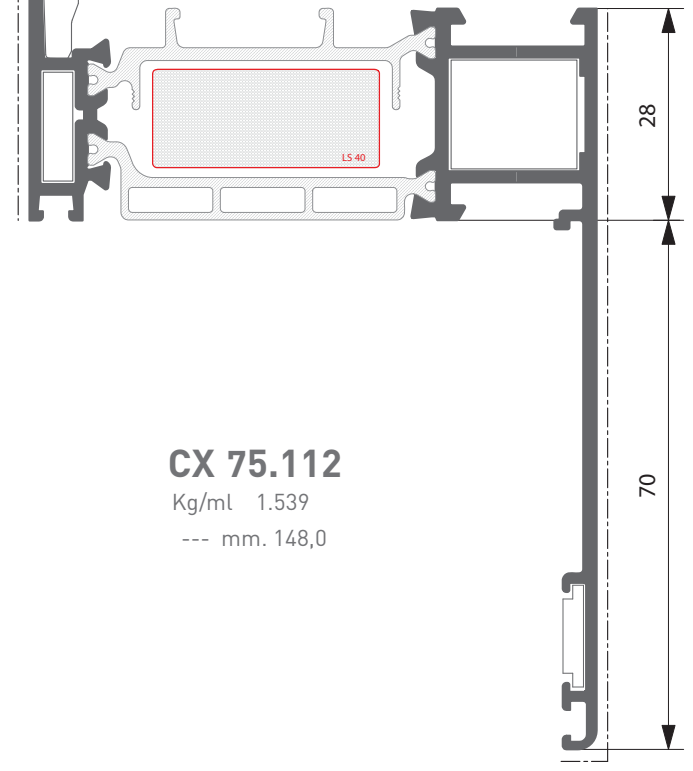
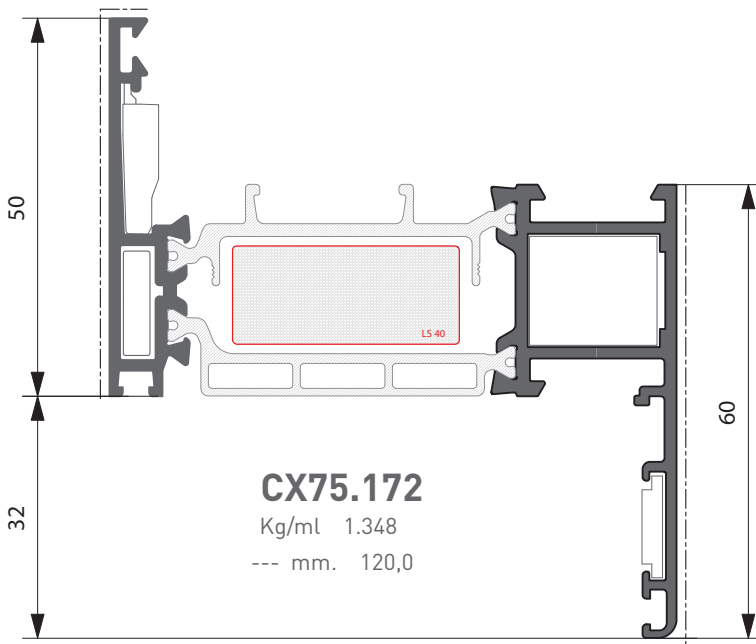
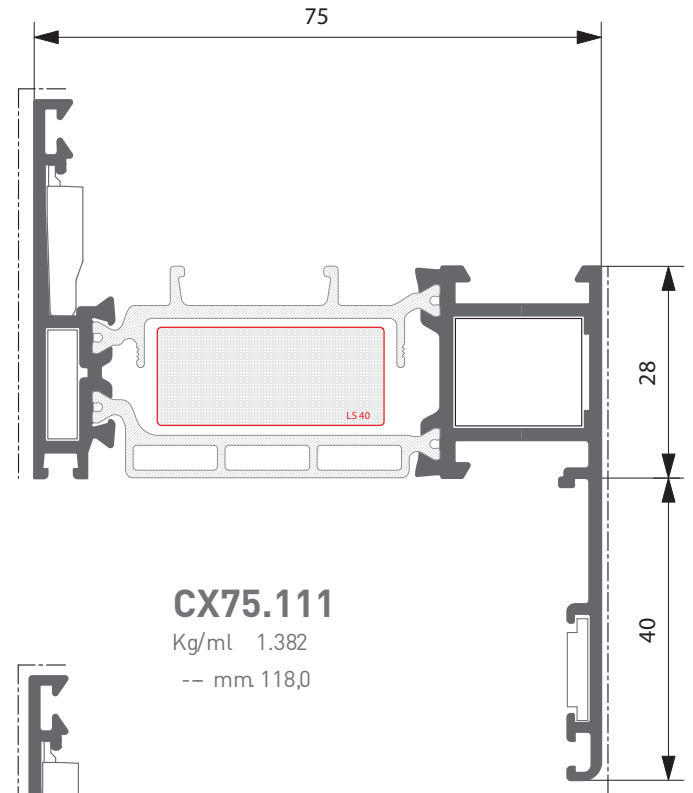
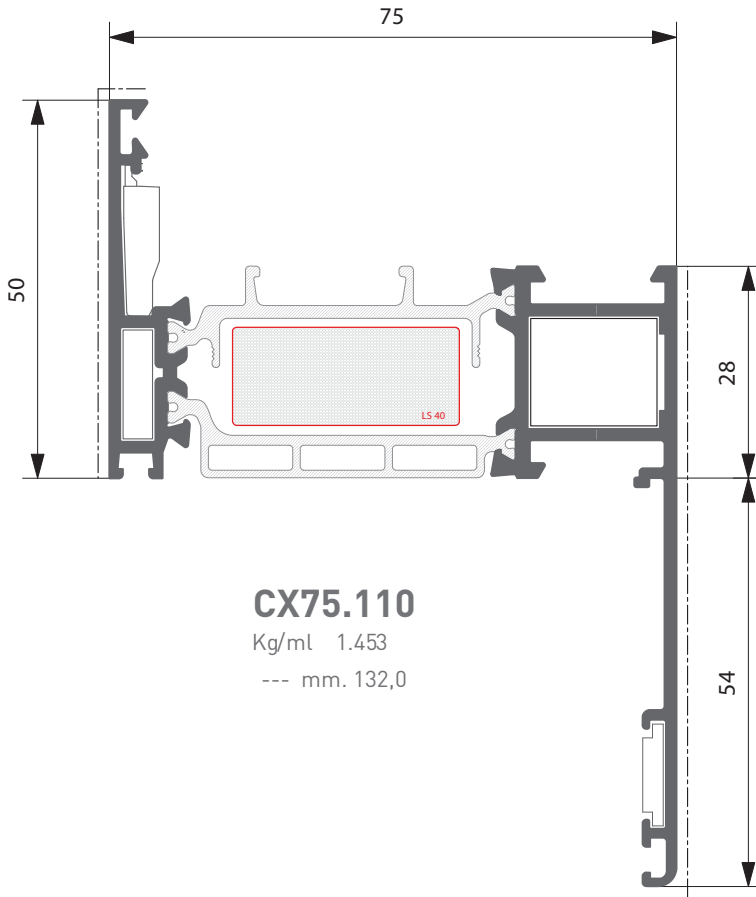

Profilato Profile	Squadretta esterna   External Corner Joint		Squadretta Interna   Internal Corner Joint				Sq. Allineamento   Alining Corner J.	
	Cianfrinare Riveting	Spinare Crimping	Bottone Slot	Cianfrinare Riveting	Spinare Crimping	Avvitare Screw	Esterna External	Interna Internal
CX75.110	ARX.03.SQ	ARX.03.SQ + ARX.08.SQ	ACX.16.SQ		AWX.19.SQ		ARX.15.SQ	ARX.10.SQ
CX75.111	ARX.03.SQ	ARX.03.SQ + ARX.08.SQ	ACX.16.SQ		AWX.19.SQ		ARX.15.SQ	ARX.10.SQ
CX75.112	ARX.03.SQ	ARX.03.SQ + ARX.08.SQ	ACX.16.SQ		AWX.19.SQ		ARX.15.SQ	ARX.10.SQ
CX75.172	ARX.03.SQ	ARX.03.SQ + ARX.08.SQ	ACX.16.SQ		AWX.19.SQ		ARX.15.SQ	ARX.10.SQ

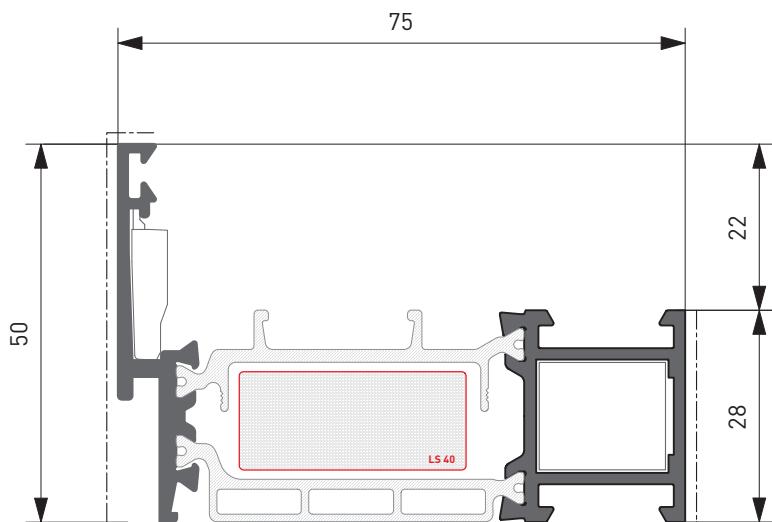

**CX75.124**

Kg/ml 1.146  
--- mm. 78,0

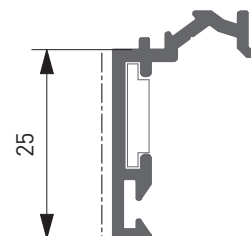

**XX70.612**

Kg/ml 0.245  
--- mm. 25,0

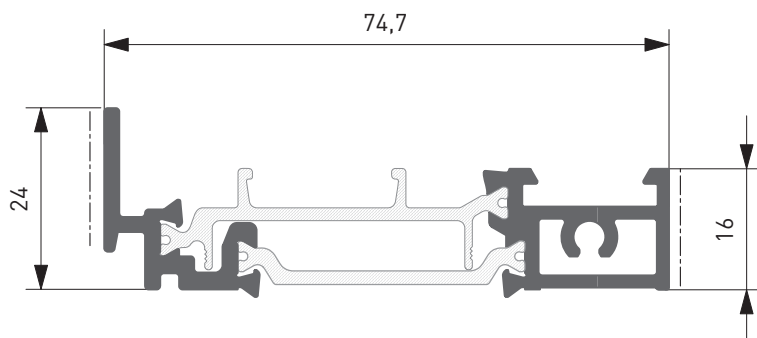

**CX75.409**

Kg/ml 0.984  
--- mm. 34,0

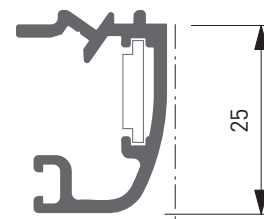

**XX60.635**

Kg/ml 0.306  
--- mm. 41,0

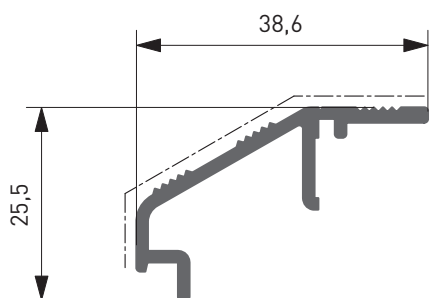

**XX70.606**

Kg/ml 0.322  
--- mm. 50,0

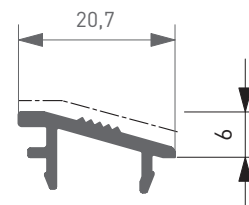

**MX603.607**

Kg/ml 0.149  
--- mm. 32,0

Profilato Profile	Squadretta esterna   External Corner Joint		Squadretta Interna   Internal Corner Joint				Sq. Allineamento   Alining Corner J.	
	Cianfrinare Riveting	Spinare Crimping	Bottone Slot	Cianfrinare Riveting	Spinare Crimping	Avvitare Screw	Esterna External	Interna Internal
CX75.124			ACX.16.SQ		AWX.19.SQ		ARX.15.SQ	
XX60.635							ARX.10.SQ	
XX70.612							ARX.10.SQ	

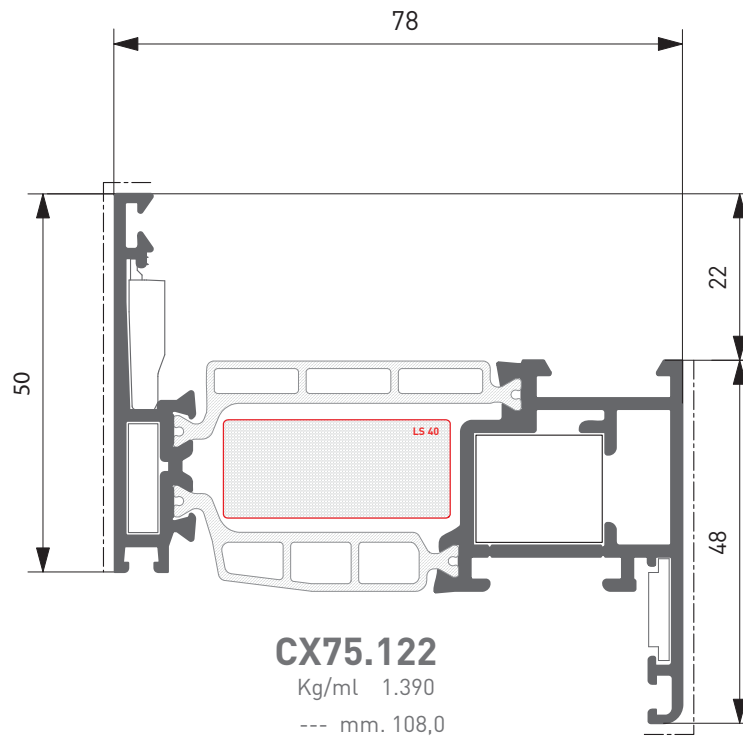
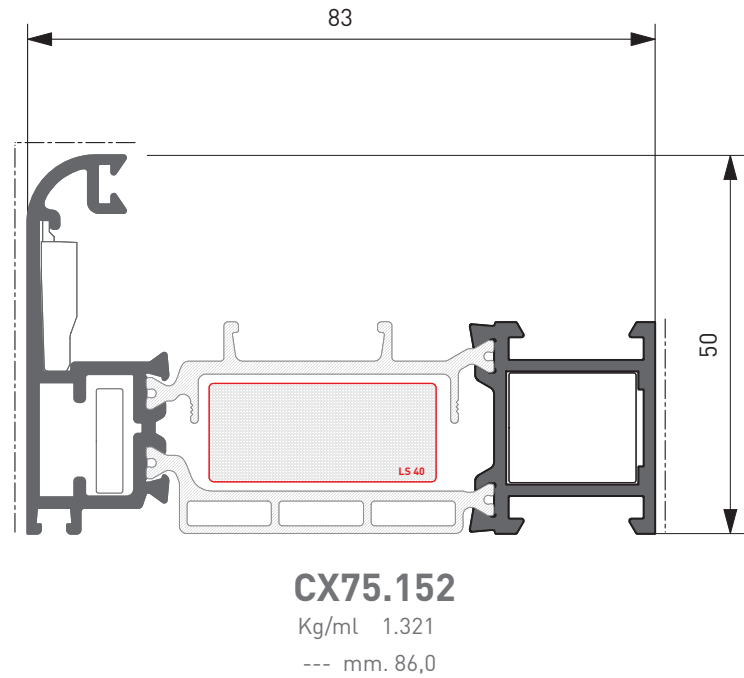
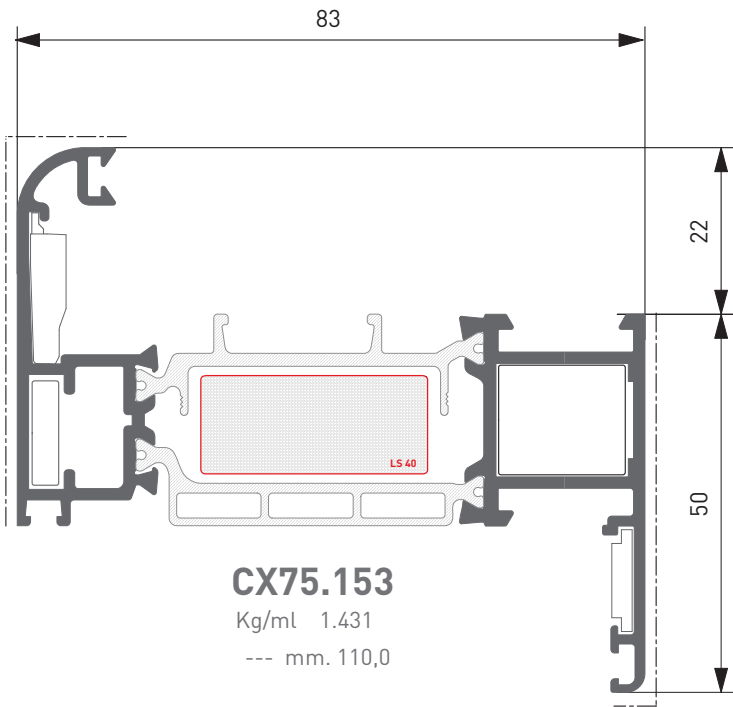

Profilato Profile	Squadretta esterna   External Corner Joint		Squadretta Interna   Internal Corner Joint				Sq. Allineamento   Alining Corner J.	
	Cianfrinare Riveting	Spinare Crimping	Bottone Slot	Cianfrinare Riveting	Spinare Crimping	Avvitare Screw	Esterna External	Interna Internal
CX75.152	ARX.03.SQ	ARX.03.SQ + ARX.08.SQ	ACX.16.SQ		AWX.19.SQ		ARX.15.SQ	
CX75.153	ARX.03.SQ	ARX.03.SQ + ARX.08.SQ	ACX.16.SQ		AWX.19.SQ		ARX.15.SQ	ARX.10.SQ
CX75.122	ARX.03.SQ	ARX.03.SQ + ARX.08.SQ	ACX.16.SQ		AWX.19.SQ		ARX.15.SQ	ARX.10.SQ

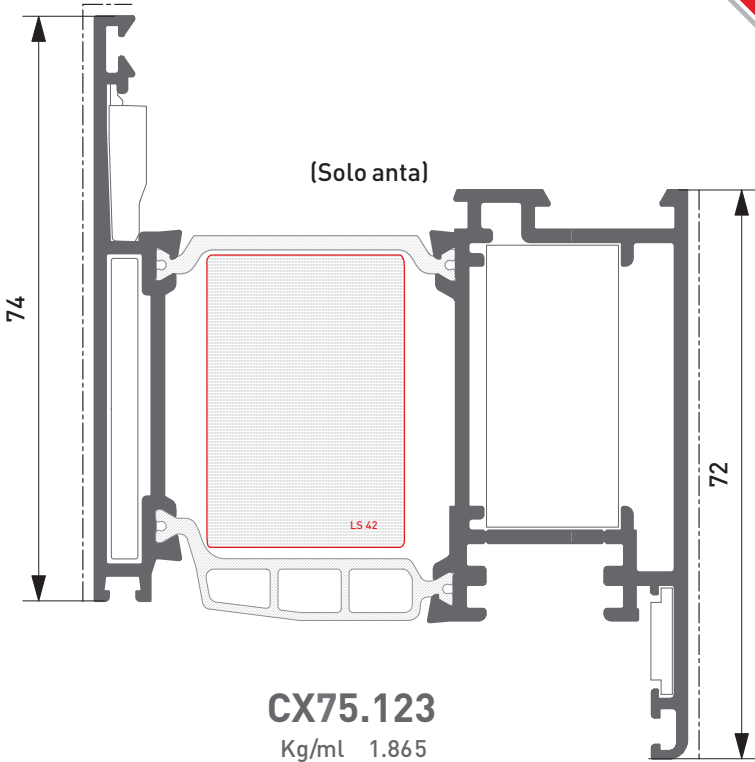

**CX75.123**  
Kg/ml 1.865  
-- mm. 146

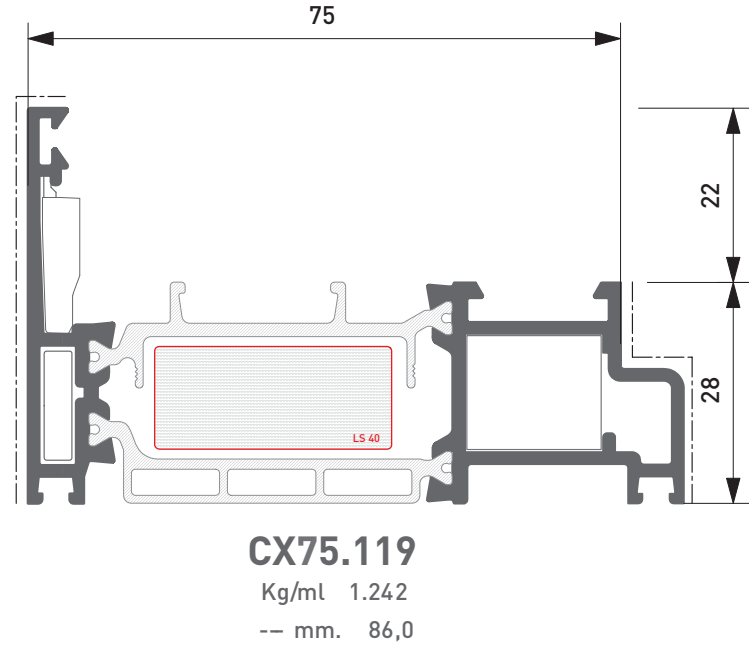

**CX75.119**  
Kg/ml 1.242  
-- mm. 86,0

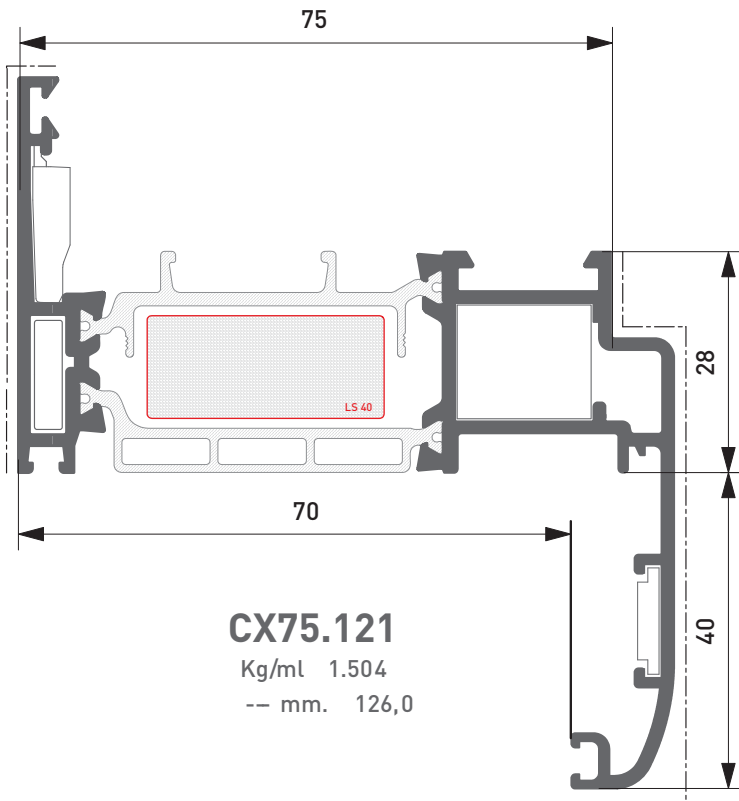

**CX75.121**  
Kg/ml 1.504  
-- mm. 126,0

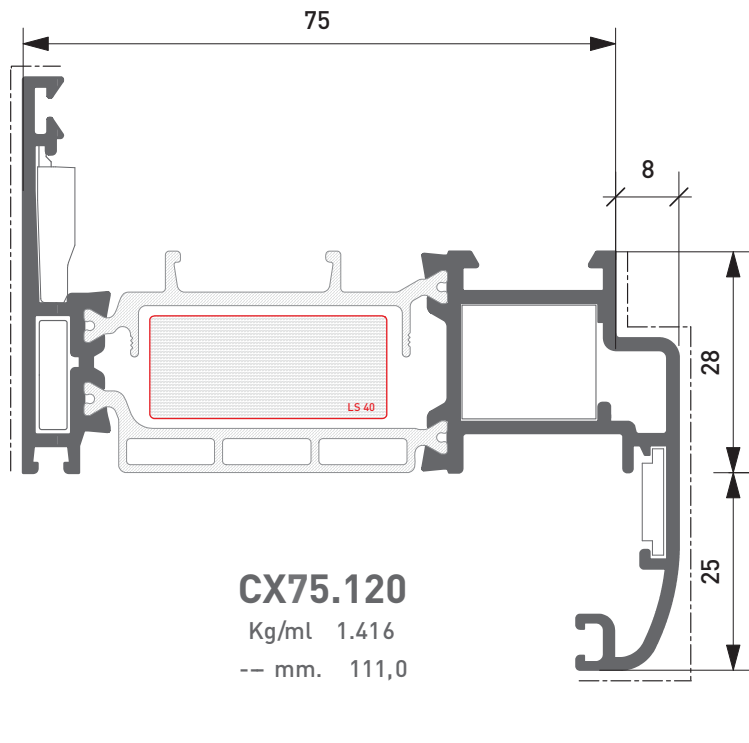

**CX75.120**  
Kg/ml 1.416  
-- mm. 111,0

Profilato Profile	Squadretta esterna   External Corner Joint				Squadretta Interna   Internal Corner Joint						Sq. Allineamento   Alining Corner J.			
	Cianfrinare Riveting		Spinare Crimping		Bottone Slot	Cianfrinare Riveting	Spinare Crimping	Awitare Screw		Esterna External	Interna Internal			
CX75.119	ARX.03.SQ	ARX.03.SQ + ARX.08.SQ			ACX.16.SQ		AWX.19.SQ			ARX.15.SQ				
CX75.120	ARX.03.SQ	ARX.03.SQ + ARX.08.SQ			ACX.16.SQ		AWX.19.SQ			ARX.15.SQ		ARX.10.SQ		
CX75.121	ARX.03.SQ	ARX.03.SQ + ARX.08.SQ			ACX.16.SQ		AWX.19.SQ			ARX.15.SQ		ARX.10.SQ		
CX75.123	ARX.06.SQ	ARX.06.SQ + ARX.08.SQ			ACX.16.SQ		AWX.19.SQ			ARX.15.SQ		ARX.10.SQ		

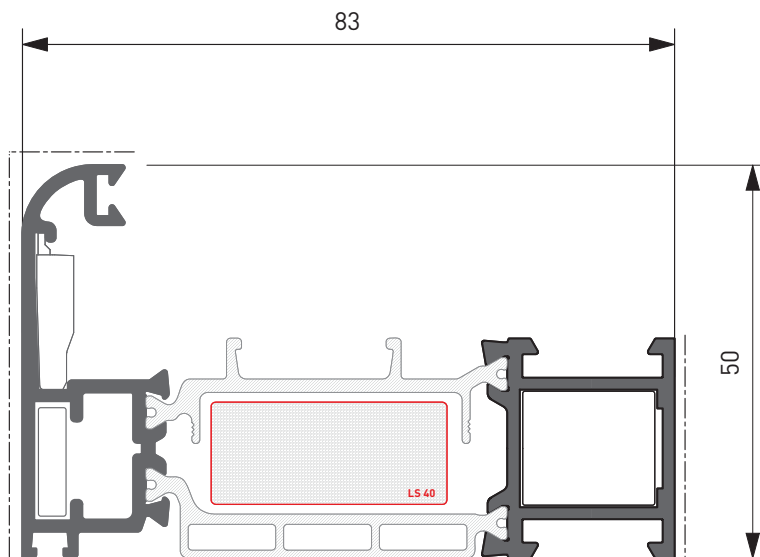

**CX75.152**

Kg/ml 1.321  
--- mm. 86,0

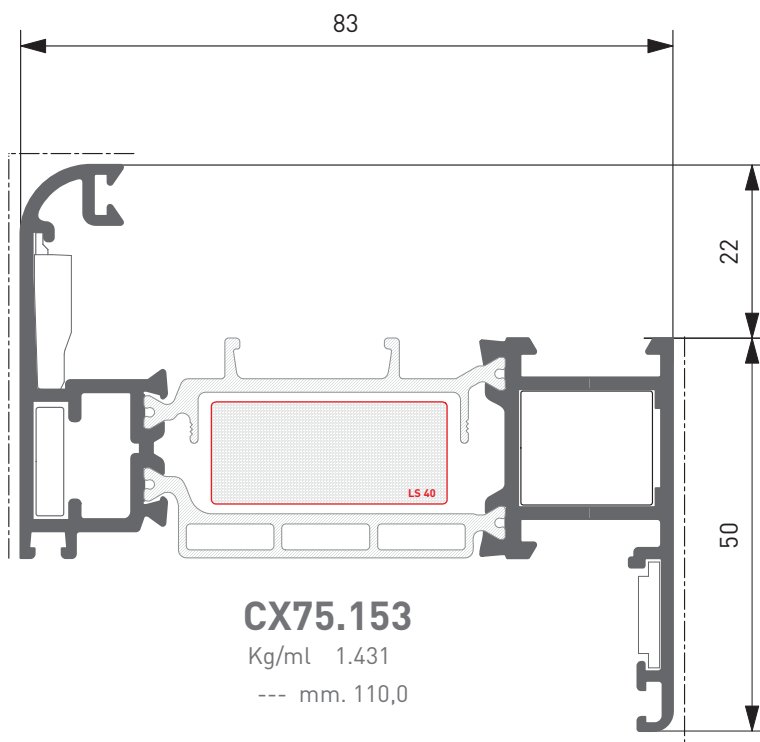

**CX75.153**

Kg/ml 1.431  
--- mm. 110,0

Profilato Profile	Squadretta esterna   External Corner Joint		Squadretta Interna   Internal Corner Joint					Sq. Allineamento   Alining Corner J.	
	Cianfrinare Riveting	Spinare Crimping	Bottone Slot	Cianfrinare Riveting	Spinare Crimping	Avitare Screw	Esterna External	Interna Internal	
CX75.152	ARX.03.SQ	ARX.03.SQ + ARX.08.SQ	ACX.16.SQ		AWX.19.SQ		ARX.15.SQ		
CX75.153	ARX.03.SQ	ARX.03.SQ + ARX.08.SQ	ACX.16.SQ		AWX.19.SQ		ARX.15.SQ	ARX.10.SQ	

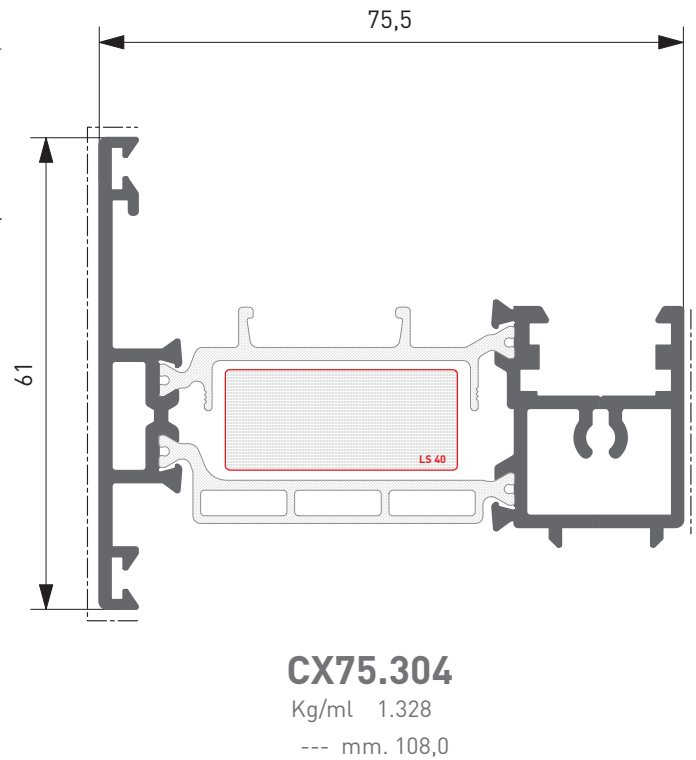
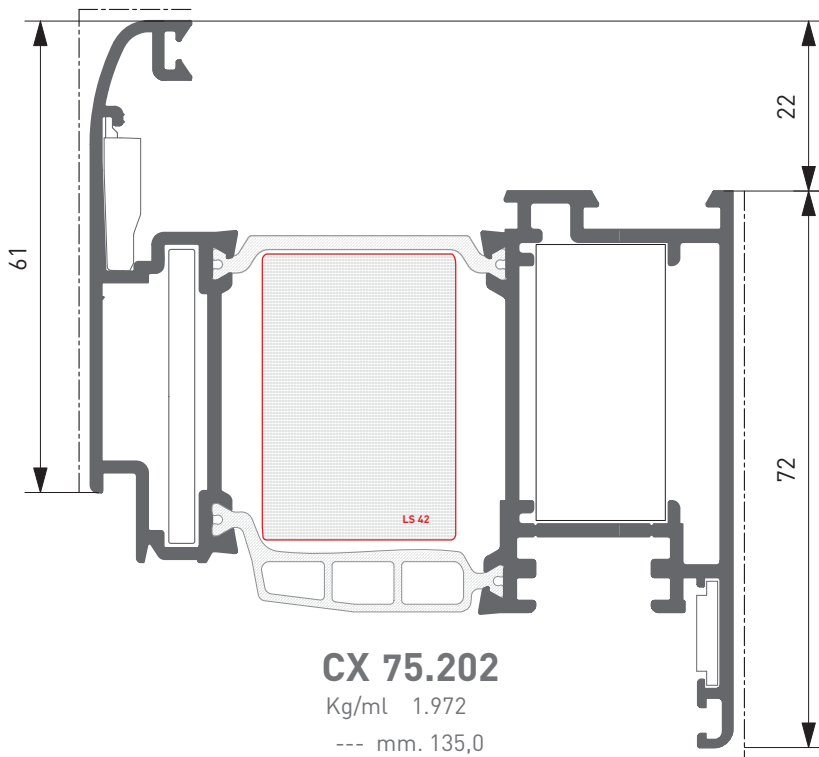
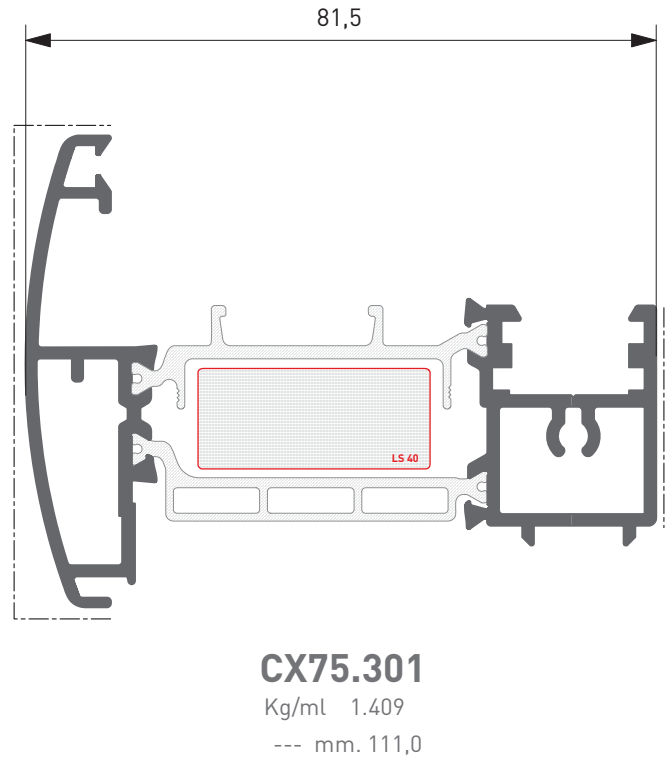
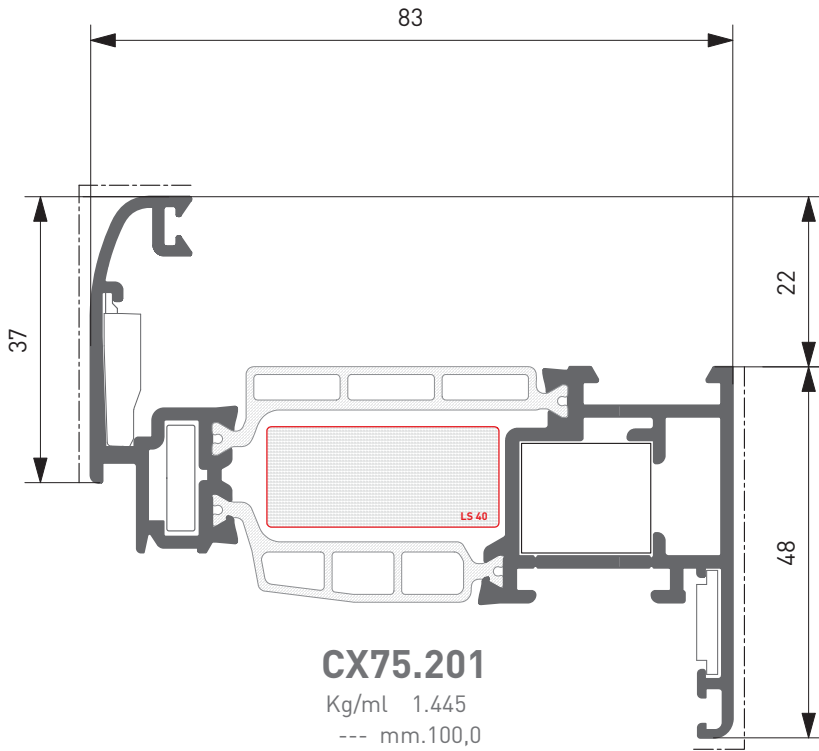

Profilato Profile	Squadretta esterna   External Corner Joint		Squadretta Interna   Internal Corner Joint				Sq. Allineamento   Alining Corner J.	
	Cianfrinare Riveting	Spinare Crimping	Bottone Slot	Cianfrinare Riveting	Spinare Crimping	Avvitare Screw	Esterna External	Interna Internal
CX75.201	ARX.03.SQ	ARX.03.SQ + ARX.08.SQ	ACX.16.SQ		AWX.19.SQ		ARX.15.SQ	ARX.10.SQ
CX 75.202	ARX.06.SQ	ARX.06.SQ + ARX.08.SQ			AWX.17.SQ		ARX.15.SQ	ARX.10.SQ

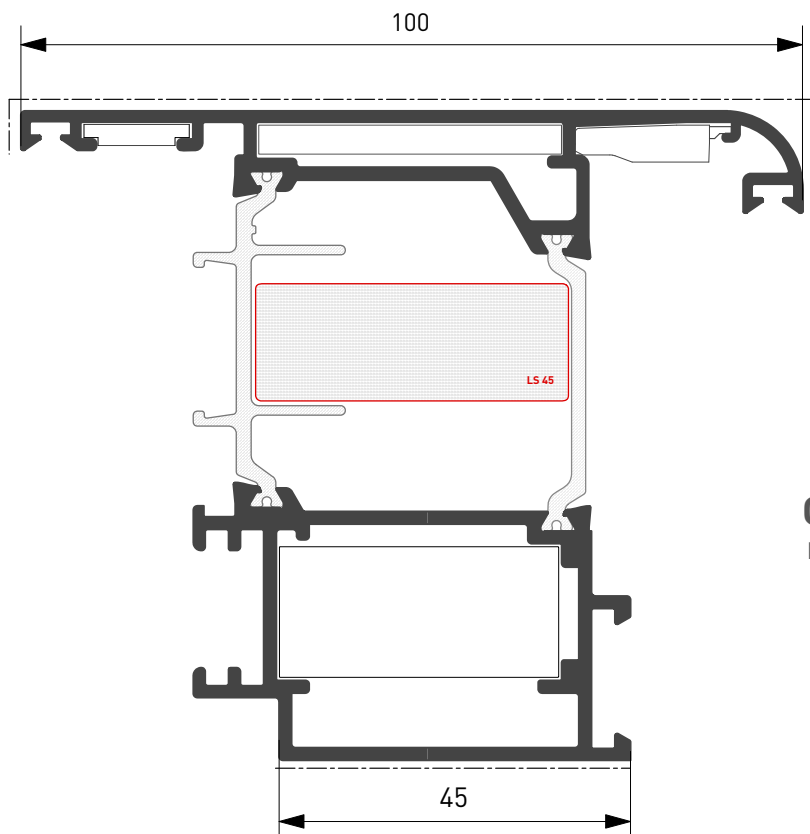

**CX75.207**

Kg/ml 2.108  
--- mm. 155,0

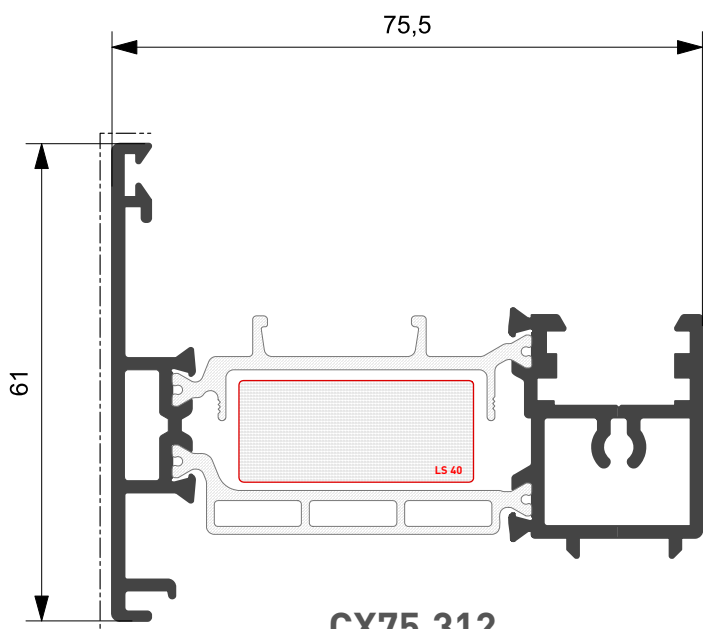

**CX75.312**

Kg/ml 1.335  
--- mm. 108,0

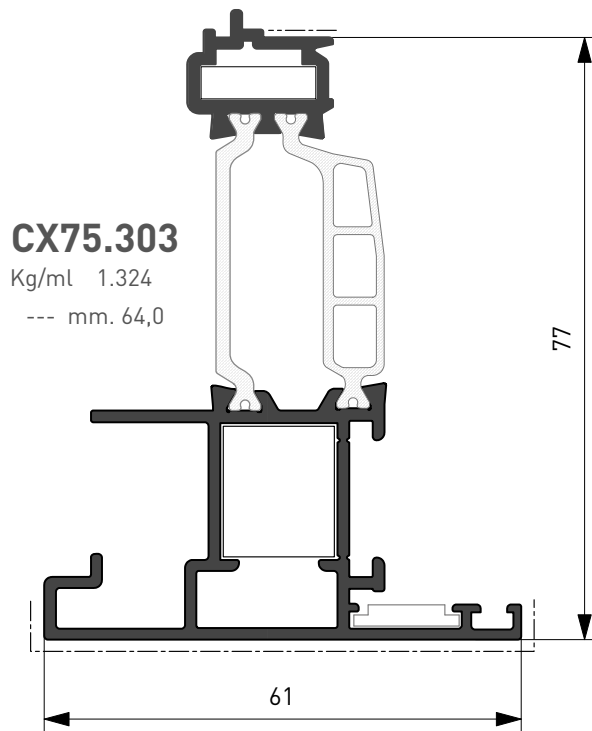

**CX75.303**

Kg/ml 1.324  
--- mm. 64,0

Profilato Profile	Squadretta esterna   External Corner Joint		Squadretta Interna   Internal Corner Joint				Sq. Allineamento   Alining Corner J.	
	Cianfrinare Riveting	Spinare Crimping	Bottone Slot	Cianfrinare Riveting	Spinare Crimping	Awitare Screw	Esterna External	Interna Internal
CX75.207	ARX.06.SQ				AWX.17.SQ		ARX.15.SQ	ARX.10.SQ
CX75.303	ARX.03.SQ	ARX.03.SQ + ARX.08.SQ			AWX.19.SQ			ARX.10.SQ
	ACX.16.SQ							

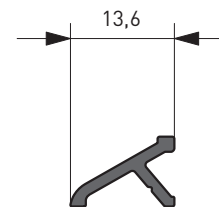
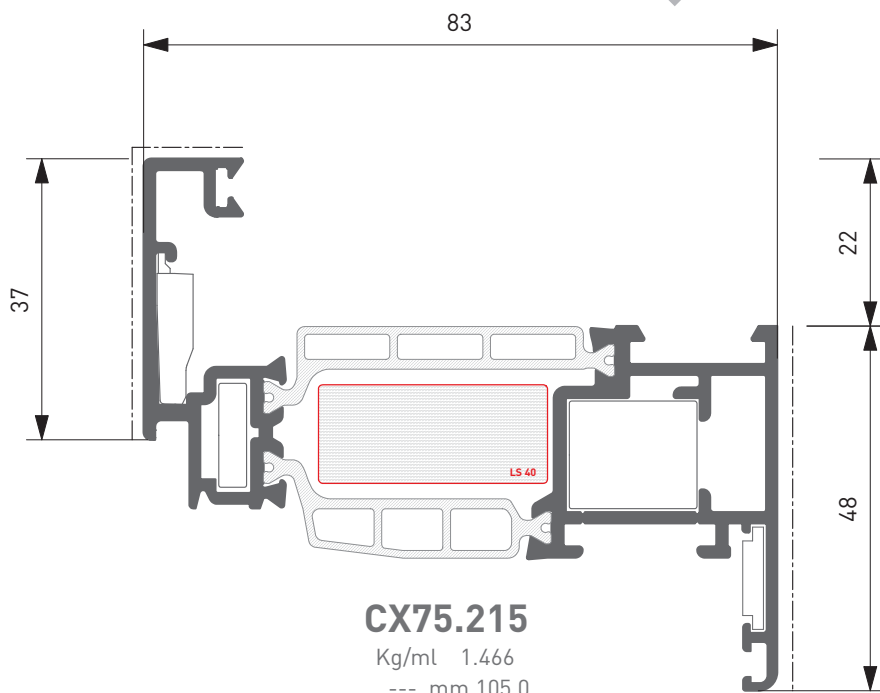

**XX70.2040**  
Kg/ml 0,095  
--- mm. 14,0

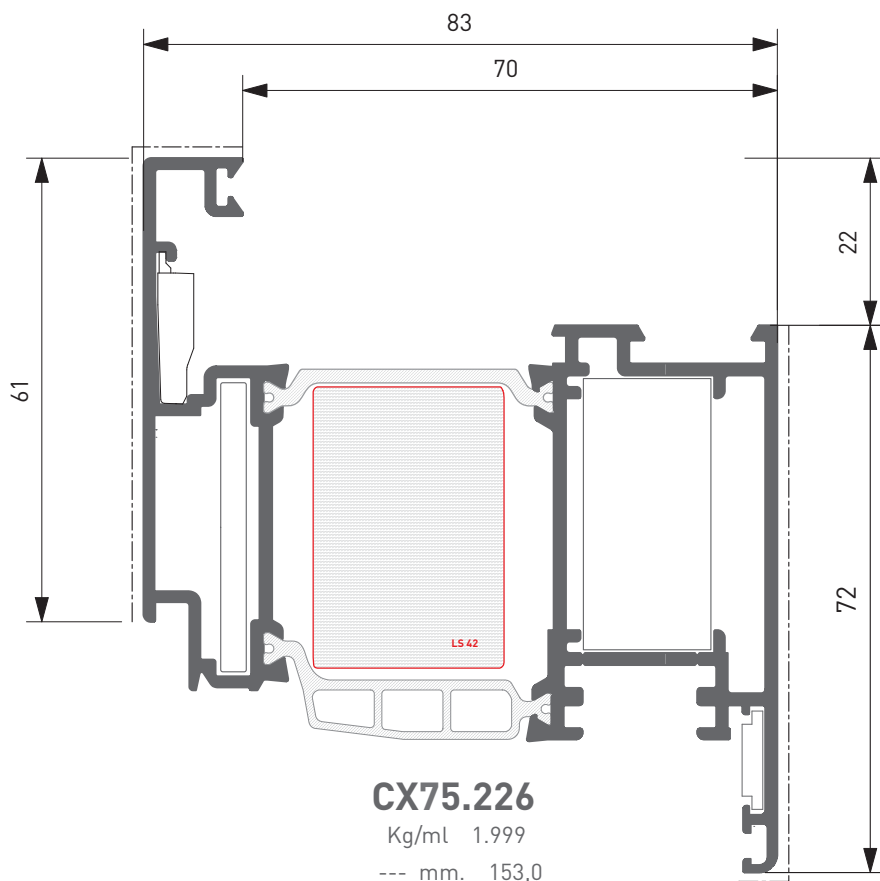

**CX70.605**  
Kg/ml 0,146  
--- mm. 14,0

Profilato Profile	Squadretta esterna   External Corner Joint		Squadretta Interna   Internal Corner Joint					Sq. Allineamento   Alining Corner J.			
	Cianfrinare Riveting	Spinare Crimping	Bottone Slot	Cianfrinare Riveting	Spinare Crimping	Avvitare Screw	Esterna External	Interna Internal	Interna Internal		
CX75.215	ARX.03.SQ	ARX.03.SQ + ARX.08.SQ	ACX.16.SQ		AWX.19.SQ		ARX.15.SQ		ARX.10.SQ		
CX75.226	ARX.06.SQ	ARX.06.SQ + ARX.08.SQ			AWX.17.SQ		ARX.15.SQ		ARX.10.SQ		

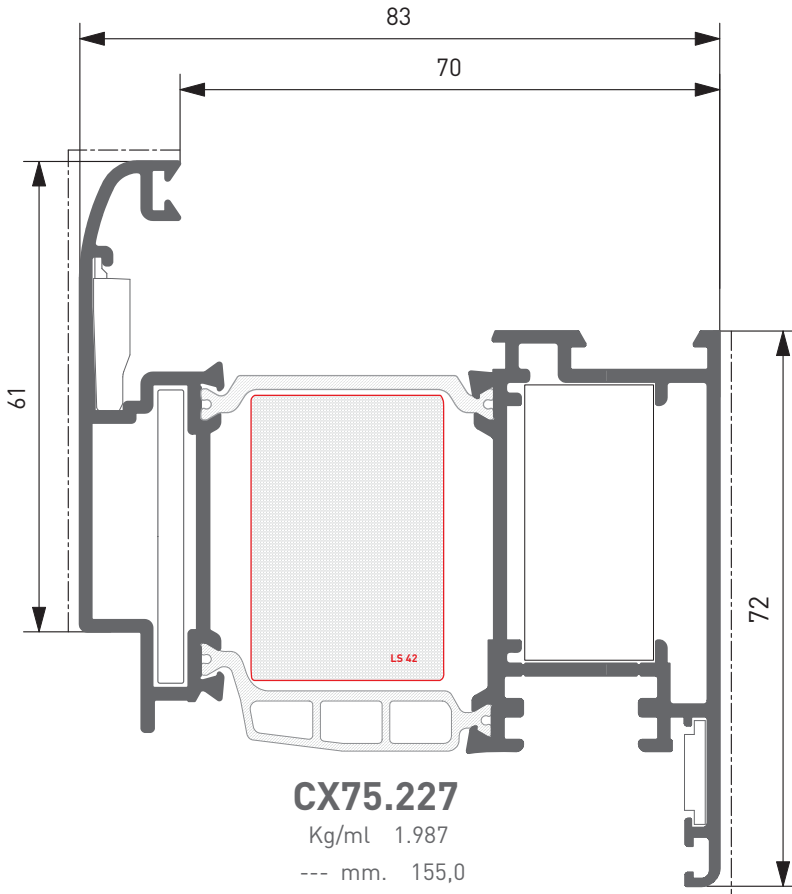

**CX75.227**

Kg/ml 1.987  
--- mm. 155,0

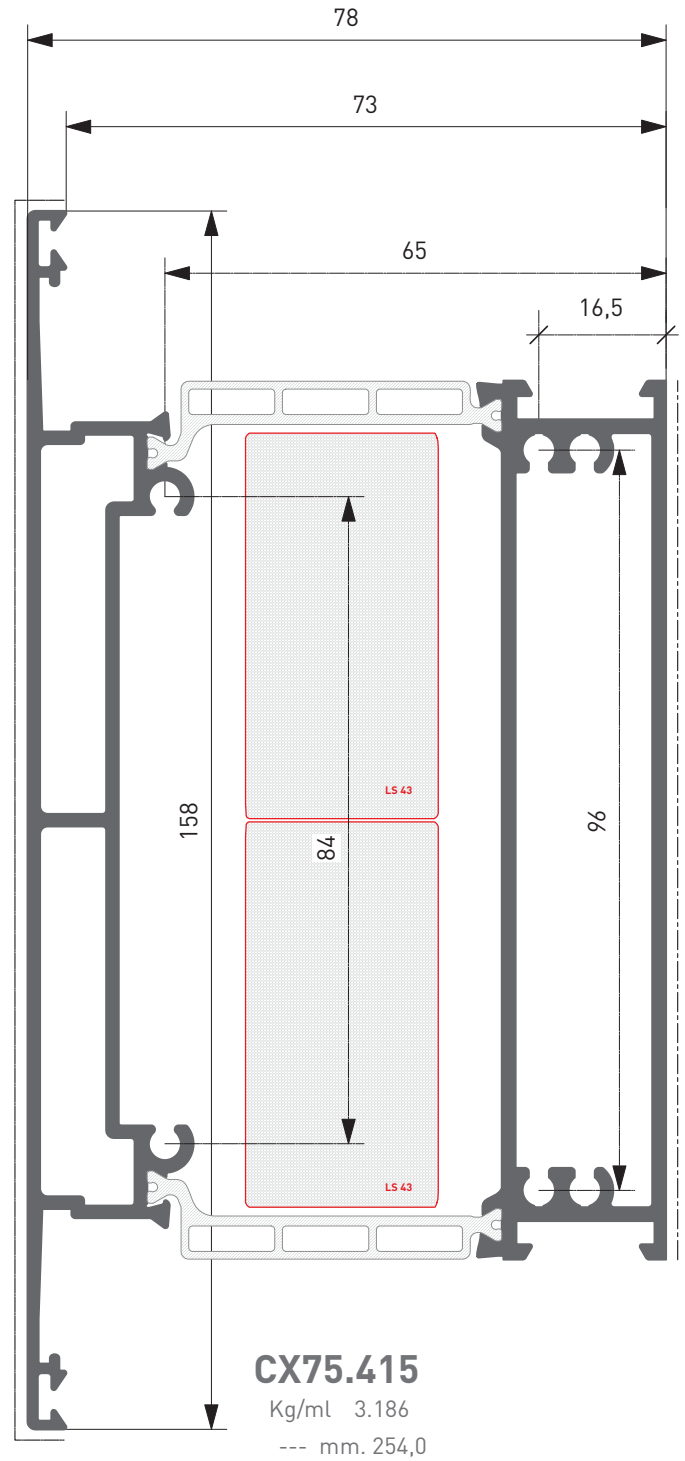

**CX75.415**

Kg/ml 3.186  
--- mm. 254,0

Profilato Profile	Squadretta esterna   External Corner Joint		Squadretta Interna   Internal Corner Joint				Sq. Allineamento   Alining Corner J.	
	Cianfrinare Riveting	Spinare Crimping	Bottone Slot	Cianfrinare Riveting	Spinare Crimping	Awitare Screw	Esterna External	Interna Internal
CX75.227	ARX.06.SQ	ARX.06.SQ + ARX.08. SQ			AWX.17.SQ		ARX.15.SQ	ARX.10.SQ



**FERRAMENTA A NASTRO  
TAPE HARDWARE**

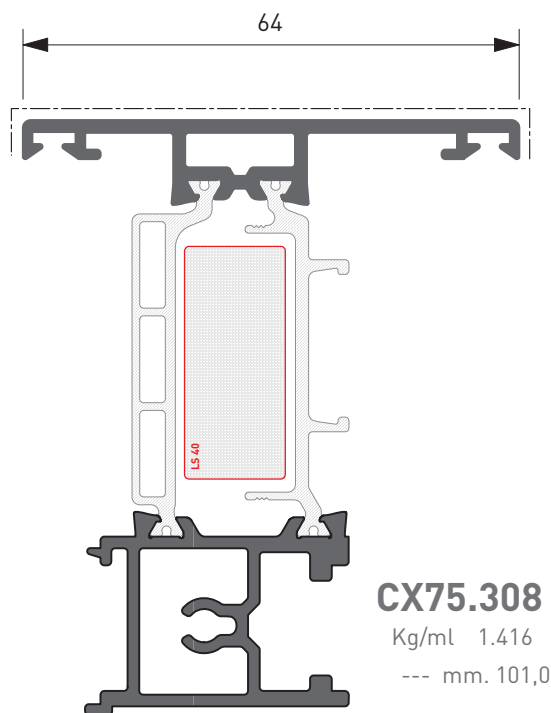
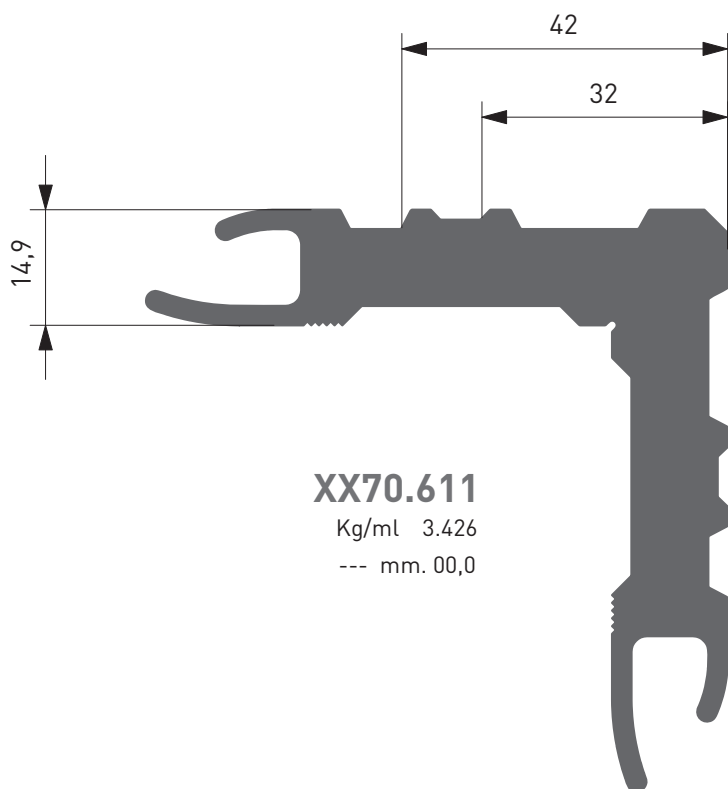
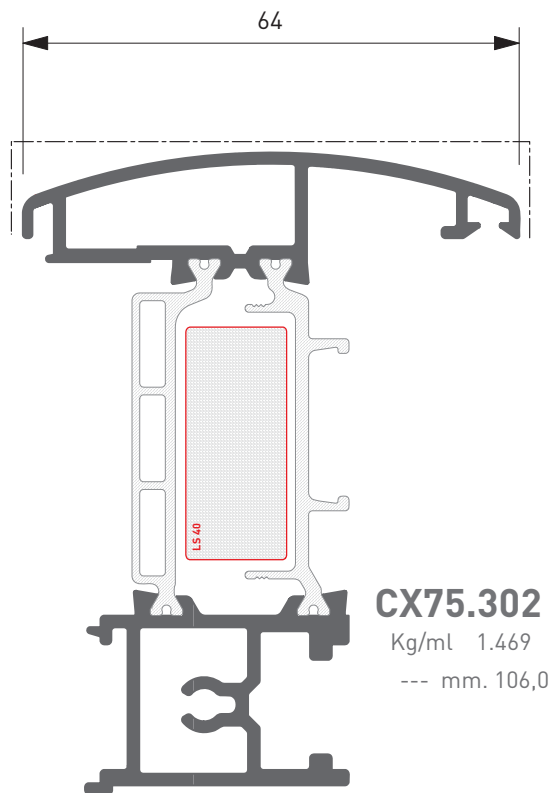
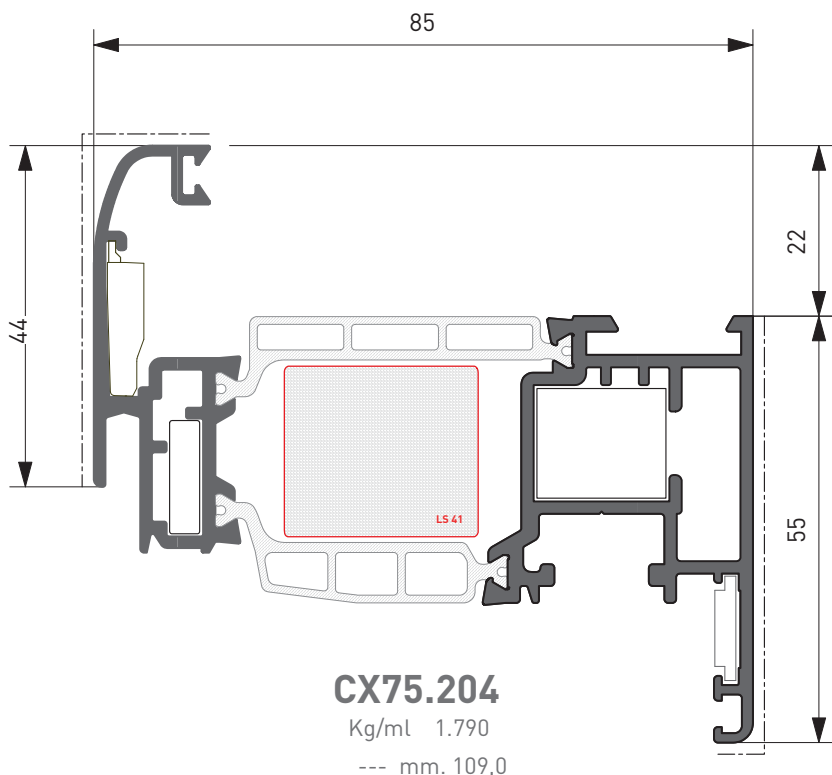

Profilato Profile	Squadretta esterna   External Corner Joint		Squadretta Interna   Internal Corner Joint					Sq. Allineamento   Alining Corner J.	
	Cianfrinare Riveting	Spinare Crimping	Bottone Slot	Cianfrinare Riveting	Spinare Crimping	Avitare Screw	Esterna External	Interna Internal	
CX75.204	ARX.03.SQ	ARX.03.SQ + ARX.08.SQ	ACX.16.SQ	AWX.19.SQ			ARX.15.SQ	ARX.10.SQ	

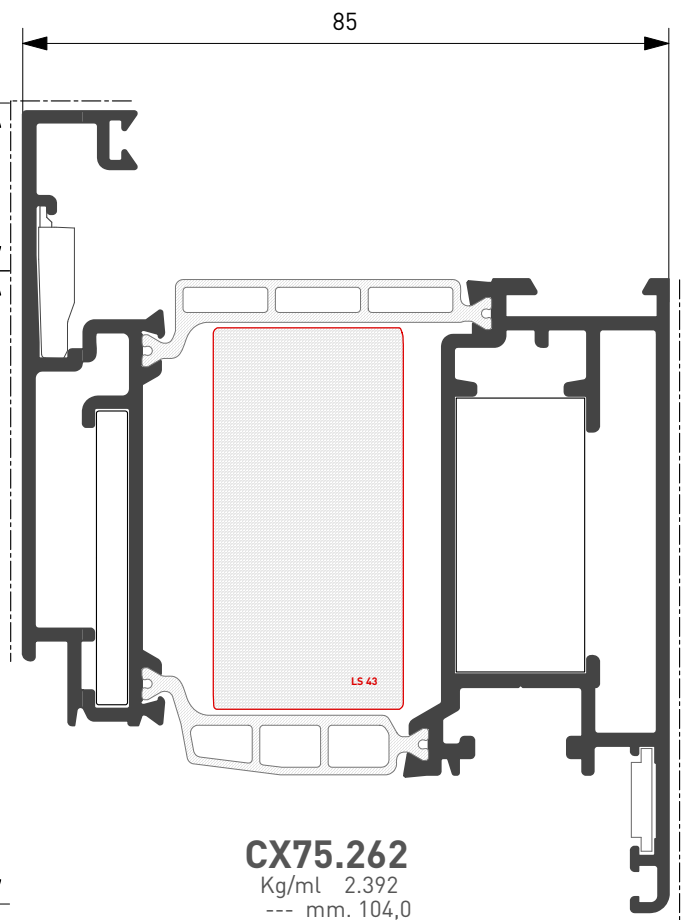
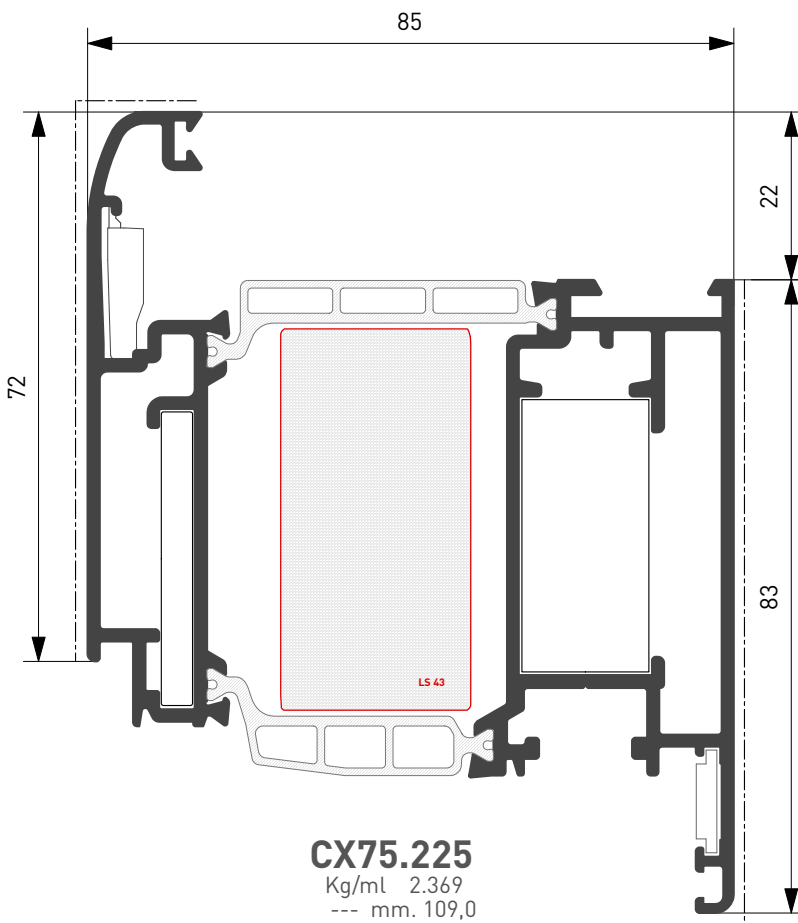
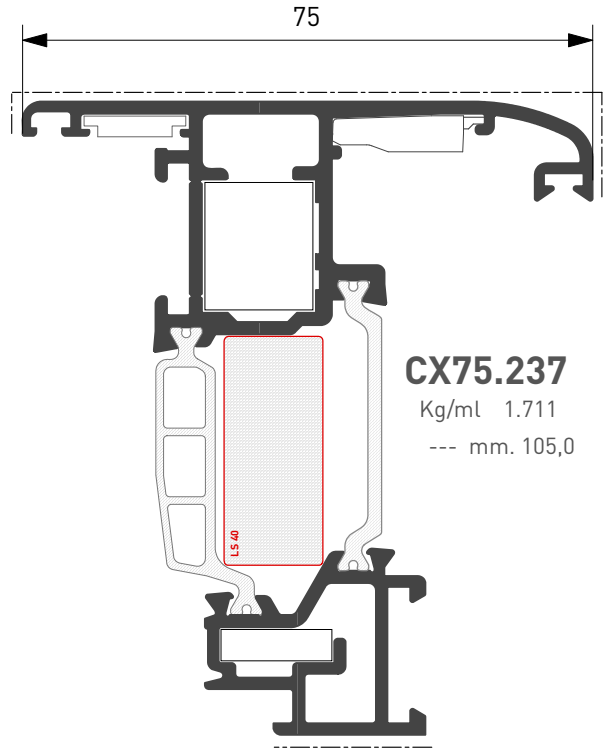
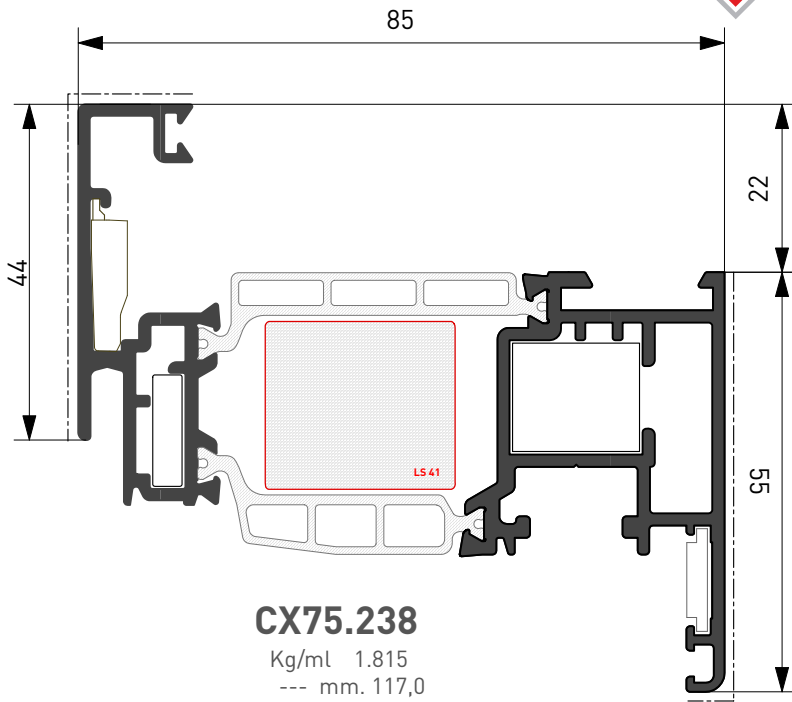

Profilato Profile	Squadretta esterna   External Corner Joint				Squadretta Interna   Internal Corner Joint						Sq. Allineamento   Alining Corner J.			
	Cianfrinare Riveting		Spinare Crimping		Bottoni Slot	Cianfrinare	Riveting	Spinare Crimping	Avvitare Screw	Esterna External	Esterna	Interna Internal	Interna	
CX75.225	ARX.06.SQ	ARX.06.SQ + ARX.08.SQ						AWX.17.SQ		ARX.15.SQ				
CX75.237	ARX.03.SQ	ARX.03.SQ + ARX.08.SQ			ACX.16.SQ			AWX.19.SQ		ARX.15.SQ				
CX75.238	ARX.03.SQ	ARX.03.SQ + ARX.08.SQ			ACX.16.SQ			AWX.19.SQ		ARX.10.SQ				
CX75.262	ARX.06.SQ	ARX.06.SQ + ARX.08.SQ						AWX.17.SQ		ARX.15.SQ				

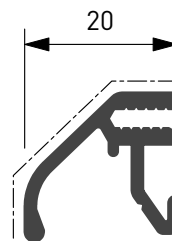
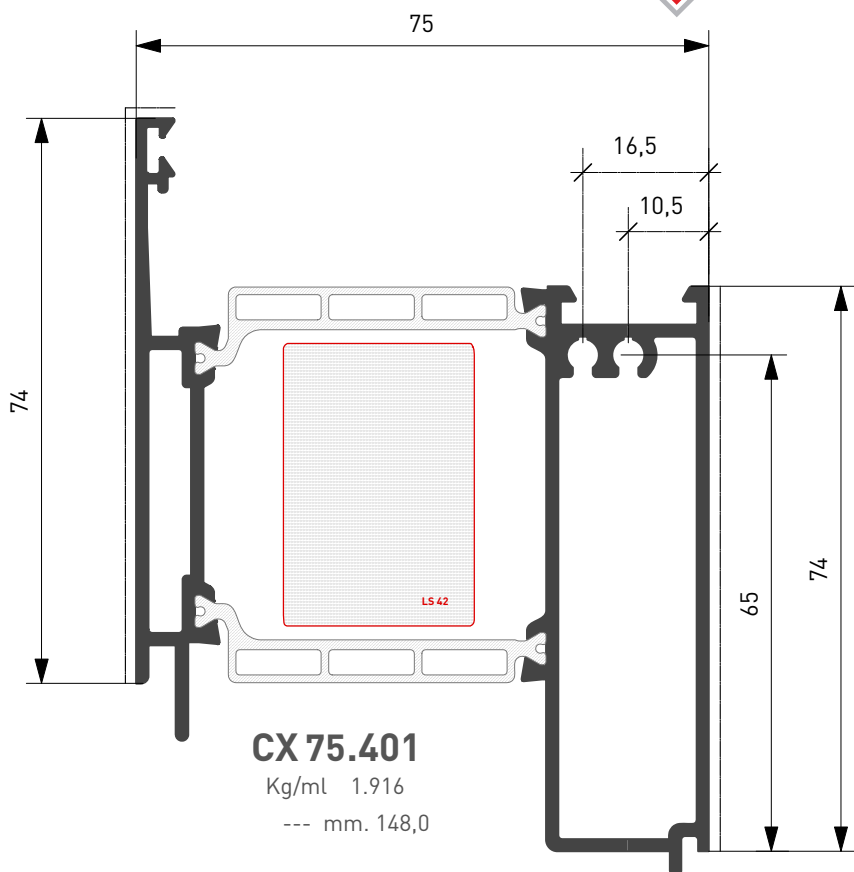

**XX70.601**

Kg/ml 0.269  
--- mm. 28,0

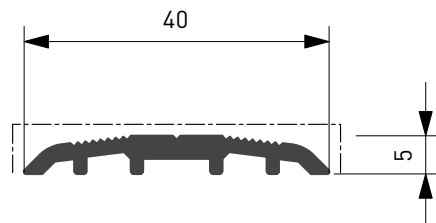
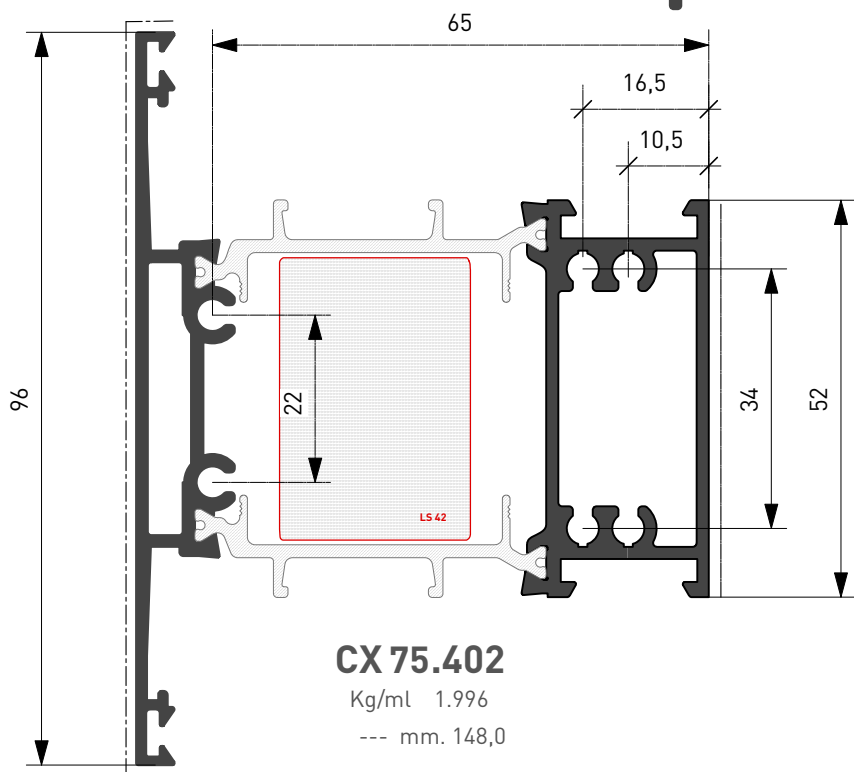

**XX70.603**

Kg/ml 0.275  
--- mm. 40,0

Profilato Profile	Squadretta esterna   External Corner Joint				Squadretta Interna   Internal Corner Joint					Sq. Allineamento   Alining Corner J.				
	Cianfrinare   Riveting		Spinare   Crimping		Bottone   Slot	Cianfrinare   Riveting		Spinare   Crimping		Avvitare   Screw		Esterna   External	Interna   Internal	

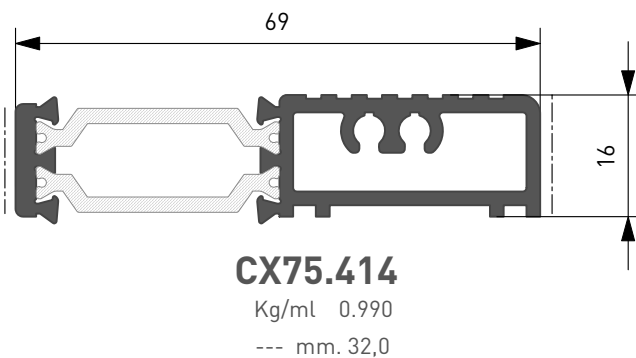
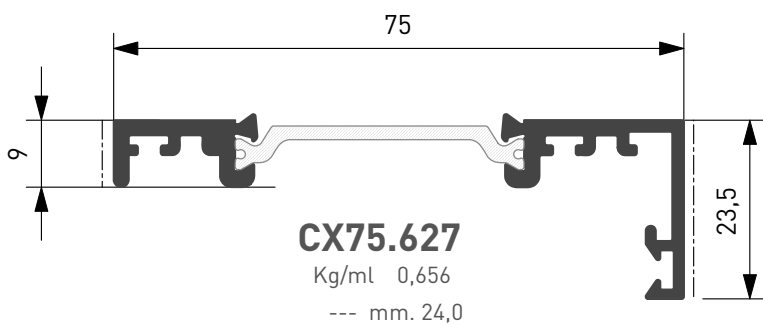
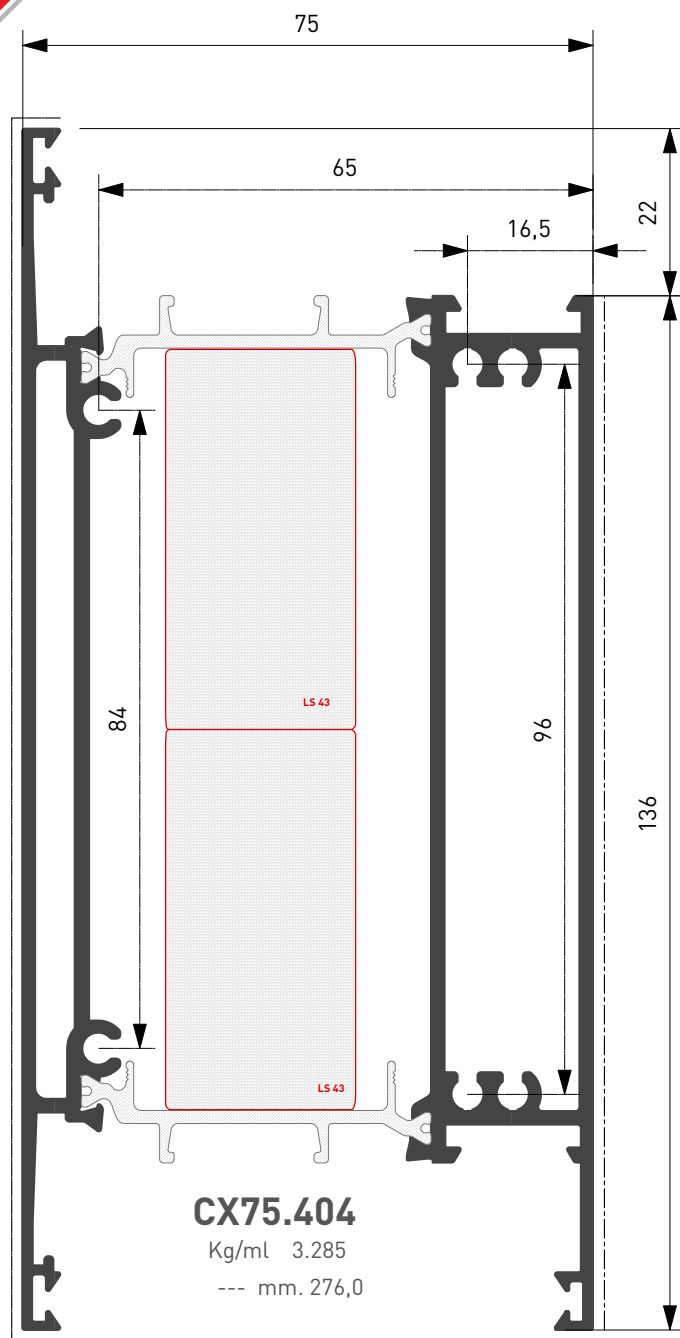
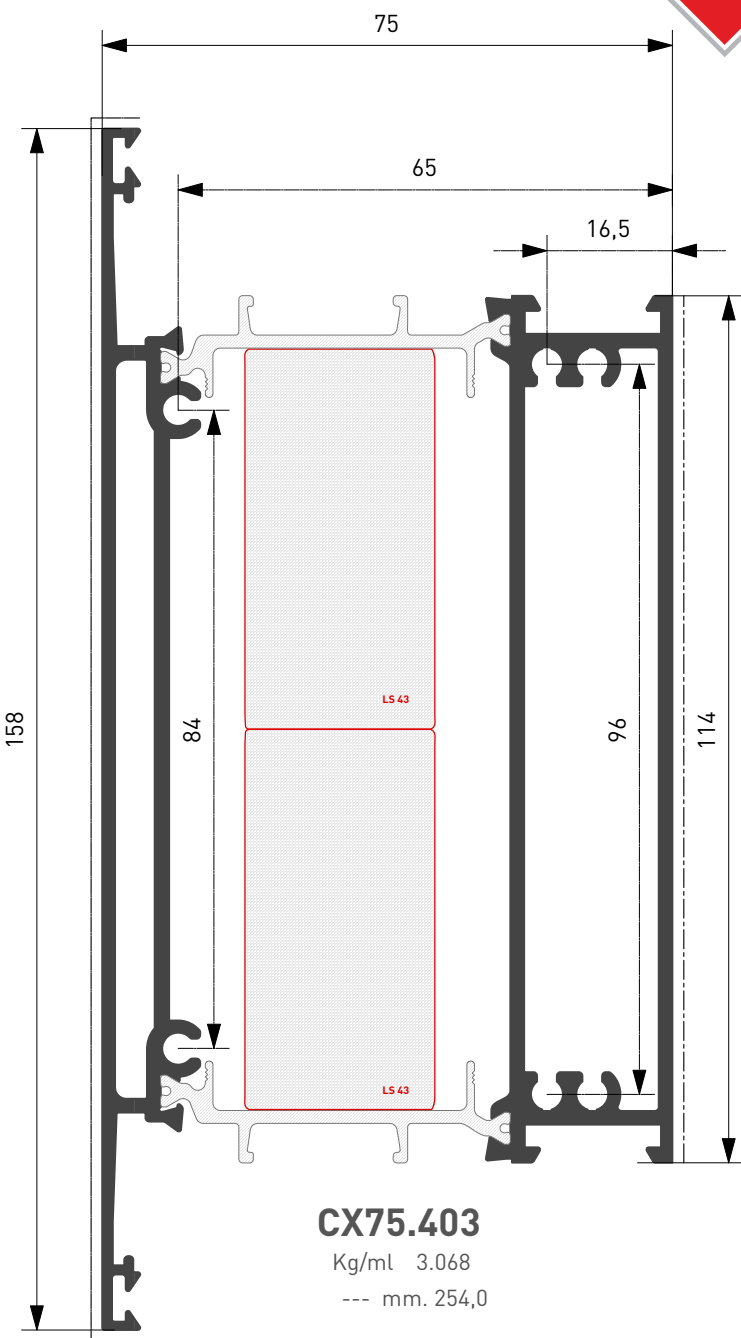

Profilato Profile	Squadretta esterna   External Corner Joint		Squadretta Interna   Internal Corner Joint				Sq. Allineamento   Alining Corner J.	
	Cianfrinare Riveting	Spinare Crimping	Bottone Slot	Cianfrinare Riveting	Spinare Crimping	Avvitare Screw	Esterna External	Interna Internal

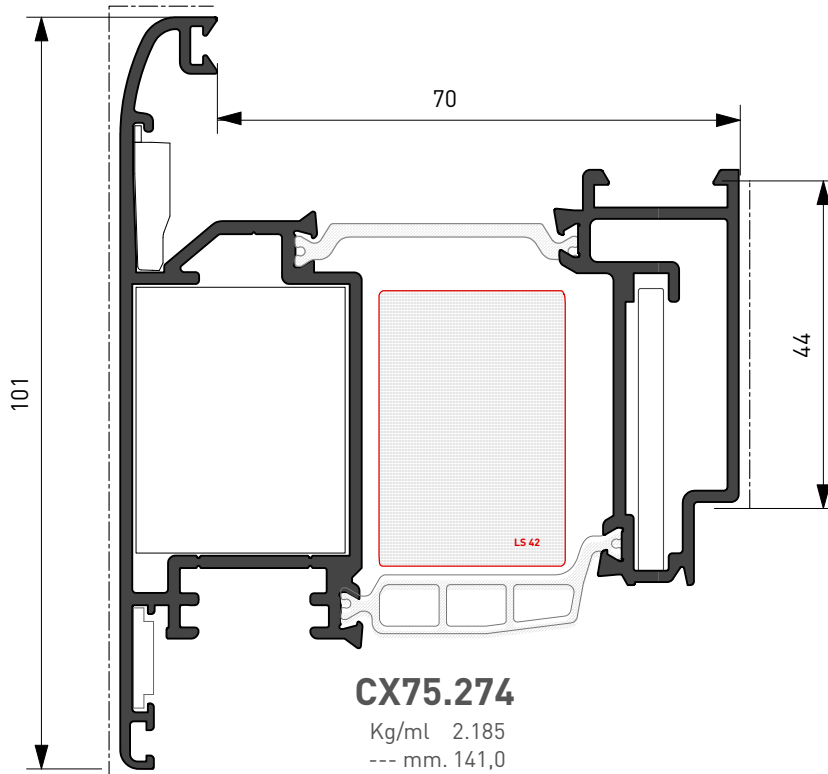
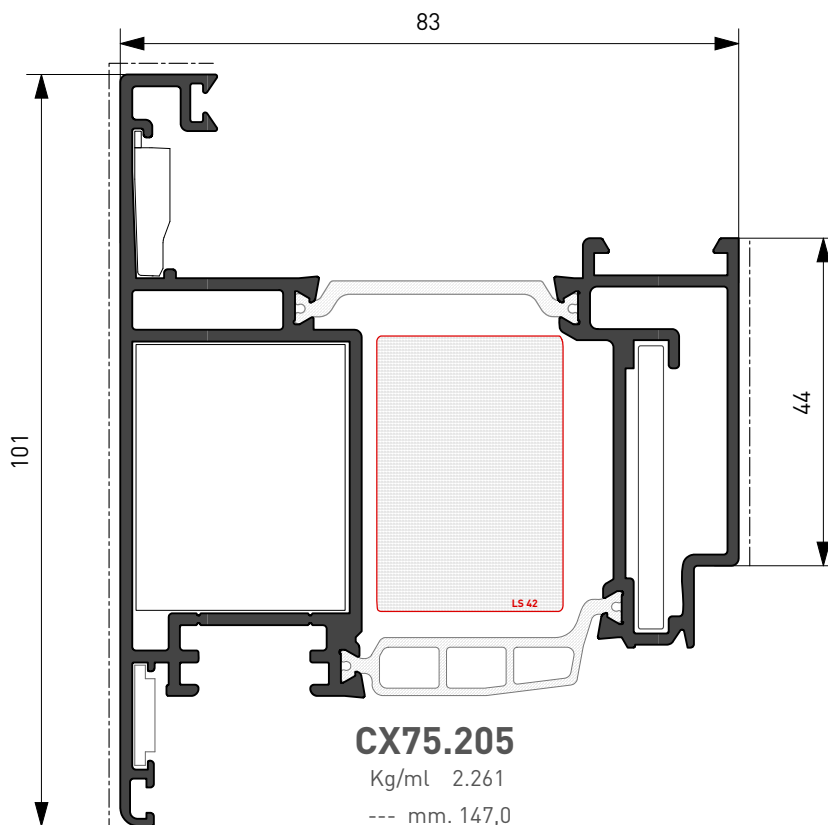

Profilato Profile	Squadretta esterna   External Corner Joint		Squadretta Interna   Internal Corner Joint				Sq. Allineamento   Alining Corner J.	
	Cianfrinare Riveting	Spinare Crimping	Bottone Slot	Cianfrinare Riveting	Spinare Crimping	Avvitare Screw	Esterna External	Interna Internal
CX75.205	ARX.06.SQ	ARX.06.SQ + ARX.08.SQ			ACX.14.SQ		ARX.15.SQ	ARX.10.SQ
CX75.274	ARX.06.SQ	ARX.06.SQ + ARX.08.SQ			ACX.14.SQ		ARX.15.SQ	ARX.10.SQ

**ATTENZIONE! Per spinatura aggiungere ACX07.SQ | Per avvitatura aggiungere VILM 5x14\_D8 [Gruppo C]**  
**ATTENTION! For crimping add ACX07.SQ | For Screw add VILM 5x14\_D8 [Group C]**

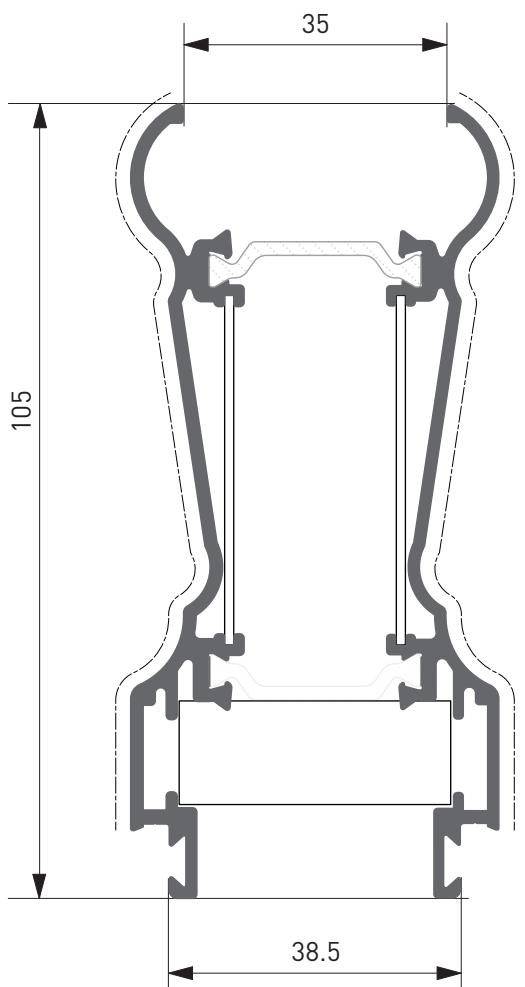

**XX70.636**

Kg/ml 1.644  
--- mm. 214,0

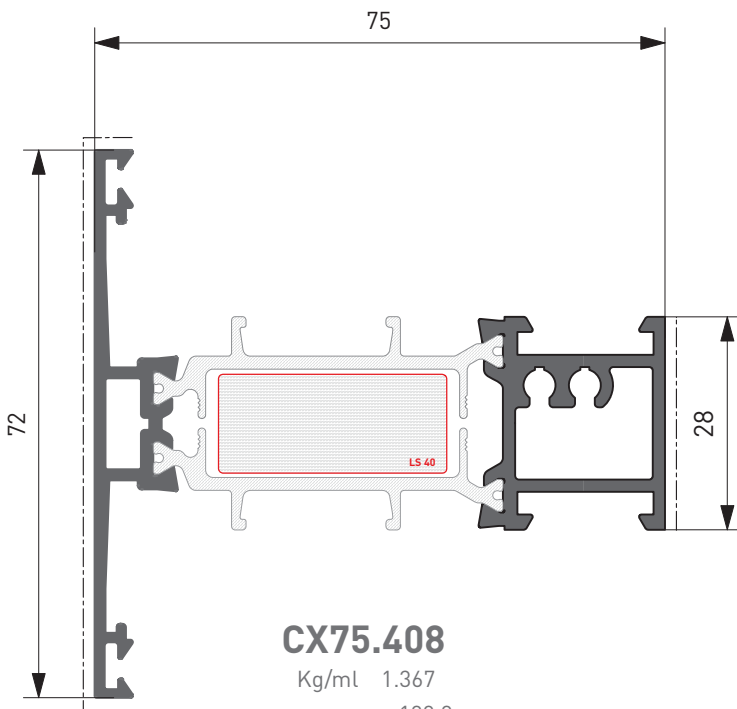
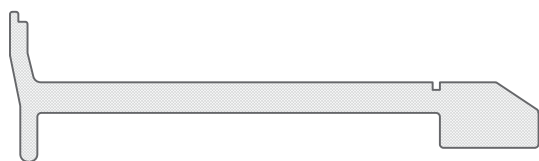

**CX75.408**

Kg/ml 1.367  
--- mm. 100,0

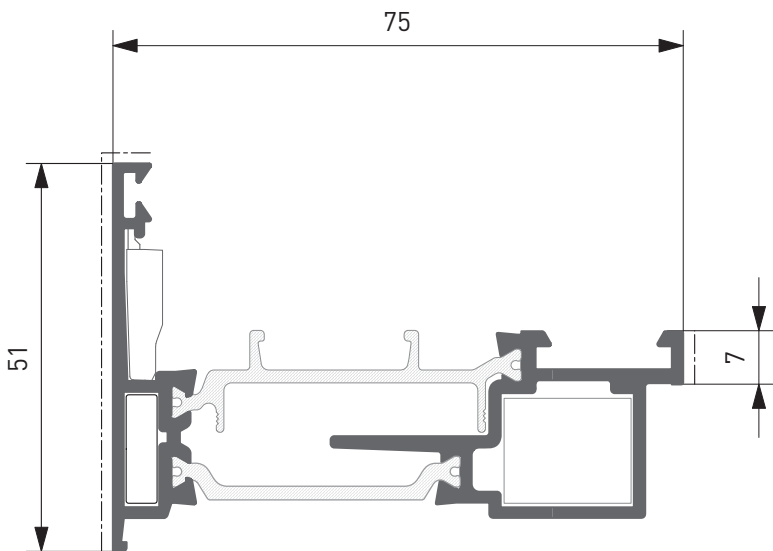

**CX75.604**

Kg/ml 1.200  
--- mm. 58,0

**CX75.640**

Kg/ml 0.966  
--- mm. 182,0

Profilato Profile	Squadretta esterna   External Corner Joint				Squadretta Interna   Internal Corner Joint					Sq. Allineamento   Alining Corner J.			
	Cianfrinare   Riveting		Spinare   Crimping		Bottone   Slot	Cianfrinare   Riveting	Spinare   Crimping	Avvitare   Screw		Esterna   External	Interna   Internal		
CX75.604	ARX.03.SQ	ARX.06.SQ + ARX.08.SQ			ACX.16.SQ	AWX.19.SQ				ARX.15.SQ			
XX70.636					ACX.72.SQ					ACX.73.SQ		ACX.73.SQ	

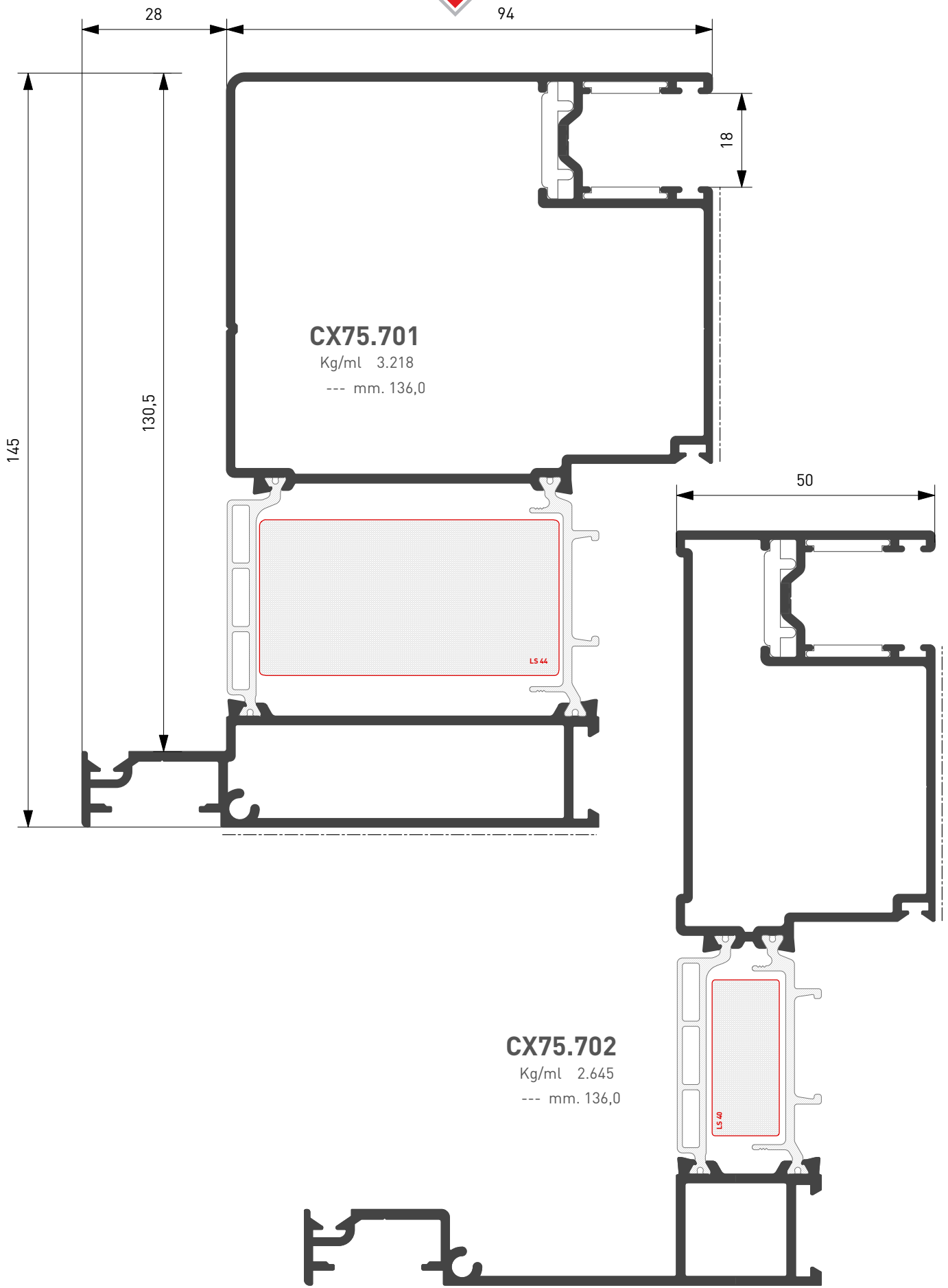

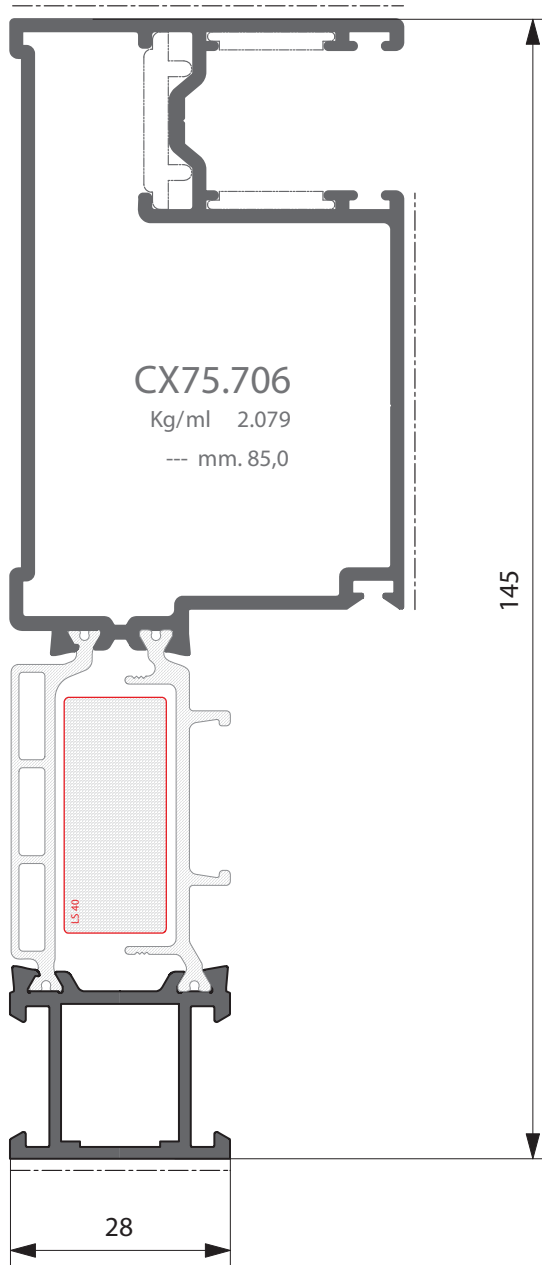

**CX75.706**  
Kg/ml 2.079  
--- mm. 85,0



**XX70.705**  
Kg/ml 0.155  
--- mm. 000,0

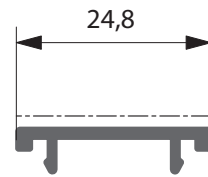

**XX70.704**  
Kg/ml 0.135  
--- mm. 25,0

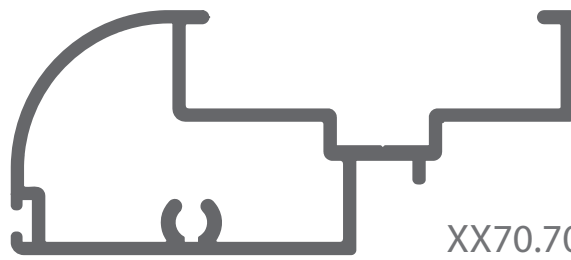

**XX70.703**  
Kg/ml 0.791  
--- mm. 43,0

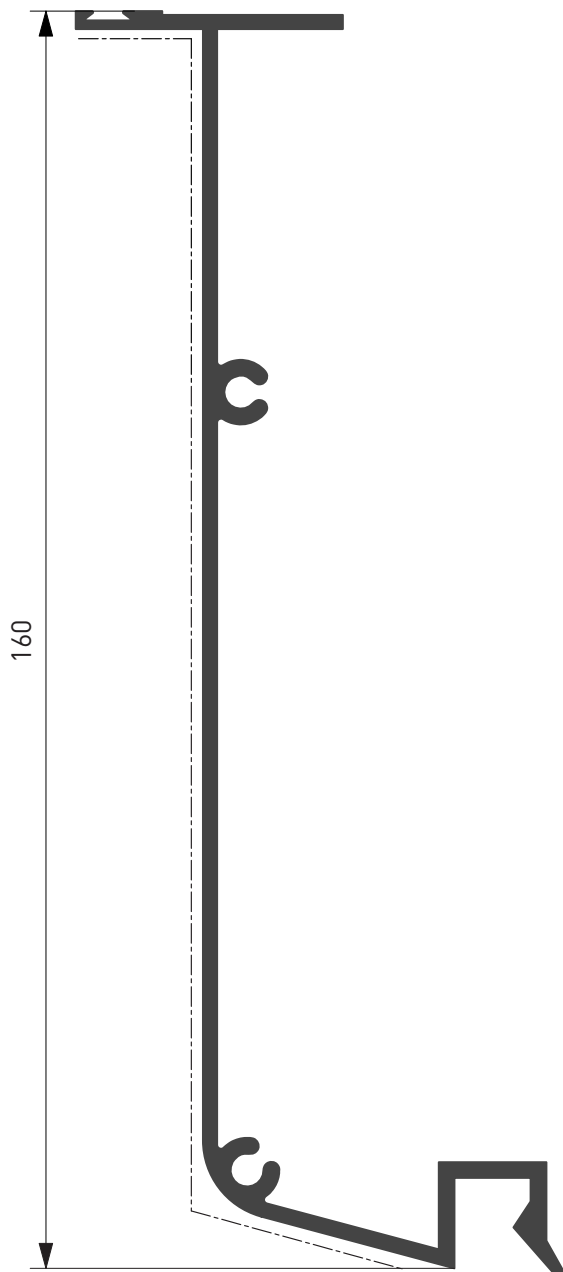

**CX45.3363**

Kg/ml 1.379

--- mm. 182,0

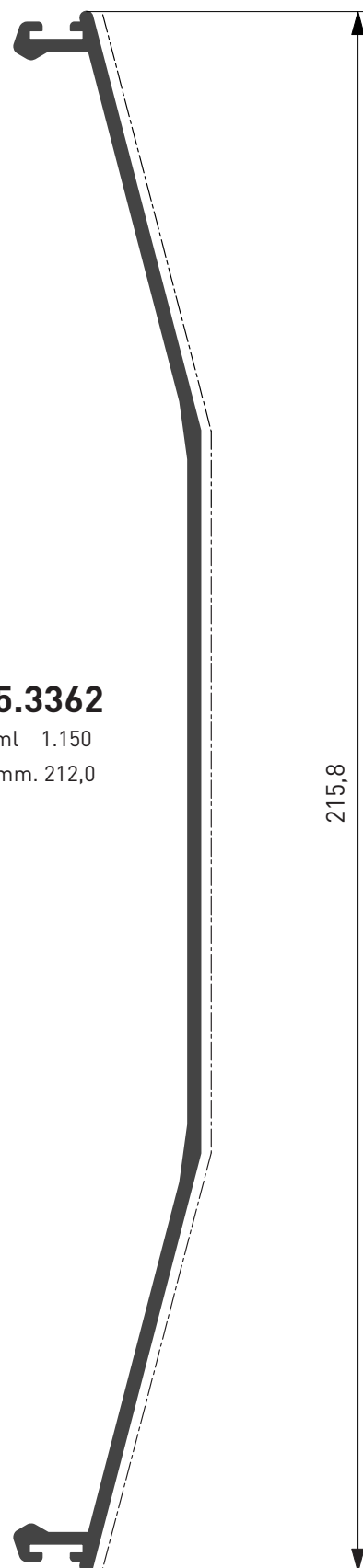

**CX45.3362**

Kg/ml 1.150

--- mm. 212,0

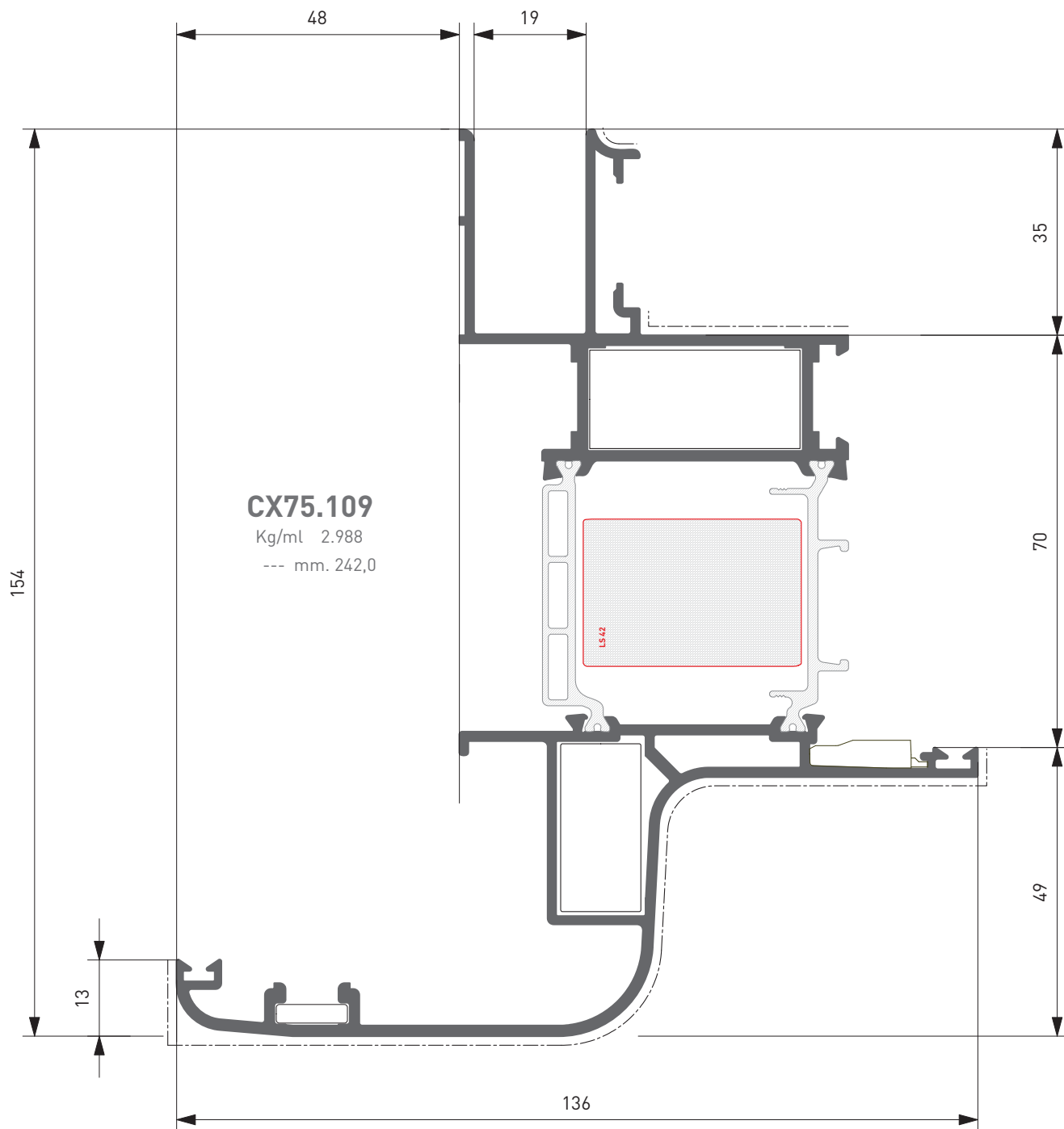

Profilato Profile	Squadretta esterna   External Corner Joint		Squadretta Interna   Internal Corner Joint					Sq. Allineamento   Alining Corner J.	
	Cianfrinare Riveting	Spinare Crimping	Bottone Slot	Cianfrinare Riveting	Spinare Crimping	Avvitare Screw	Esterna External	Interna Internal	
CX75.109	ARX.01.SQ	ARX.02.SQ			AWX.17.SQ		ARX.15.SQ	ARX.11.SQ	

**ATTENZIONE! Per spinatura aggiungere anche LM0088 | Per avvitatura aggiungere VILM 5x14\_D8 [Gruppo C]**  
**ATTENTION! For crimping add LM0088 | For Screw add VILM 5x14\_D8 [Group C]**

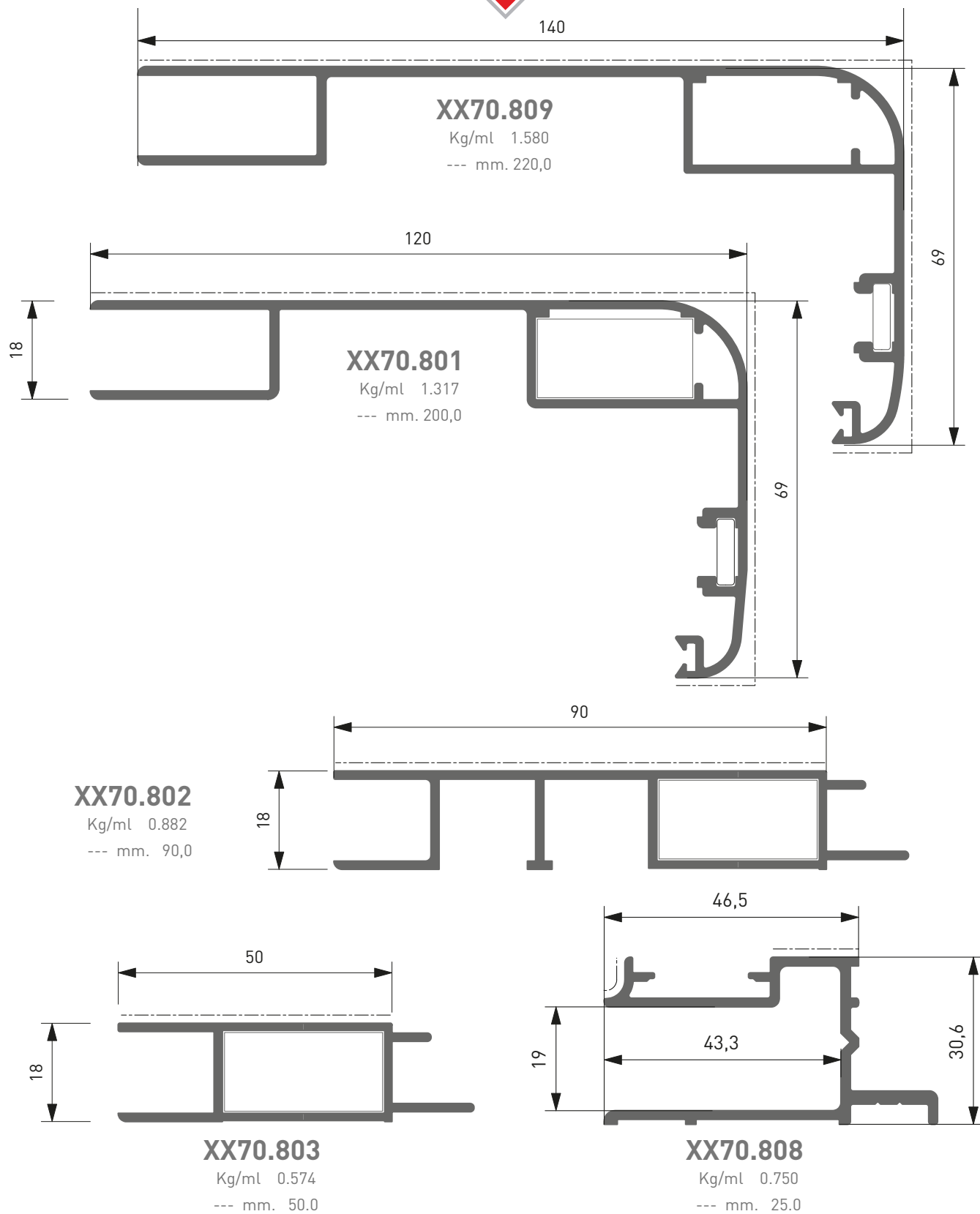

Profilato Profile	Squadretta esterna   External Corner Joint		Squadretta Interna   Internal Corner Joint				Sq. Allineamento   Alining Corner J.	
	Cianfrinare Riveting	Spinare Crimping	Bottone Slot	Cianfrinare Riveting	Spinare Crimping	Avvitare Screw	Esterna External	Interna Internal
XX70.801			ACX.16.SQ	AWX.19.SQ	AWX.19.SQ + LM 0088			ARX.11.SQ
XX70.802			ACX.16.SQ	AWX.19.SQ	AWX.19.SQ + LM 0088			
XX70.803			ACX.16.SQ	AWX.19.SQ	AWX.19.SQ + LM 0088			
XX70.809			ACX.16.SQ	AWX.19.SQ	AWX.19.SQ + LM 0088			ARX.11.SQ

**ATTENZIONE! Per spinatura aggiungere anche LM0088 | Per avvitatura aggiungere VILM 5x14\_D8 [Gruppo C]**  
**ATTENTION! For crimping add LM0088 | For Screw add VILM 5x14\_D8 [Group C]**

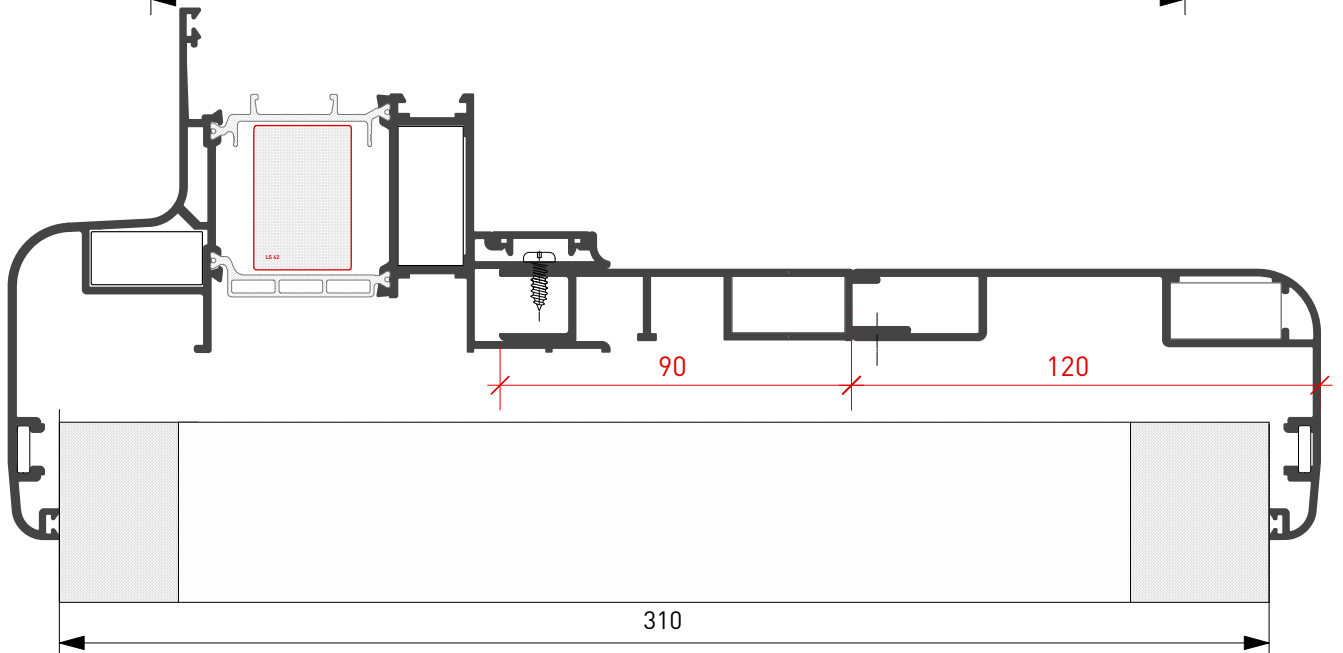
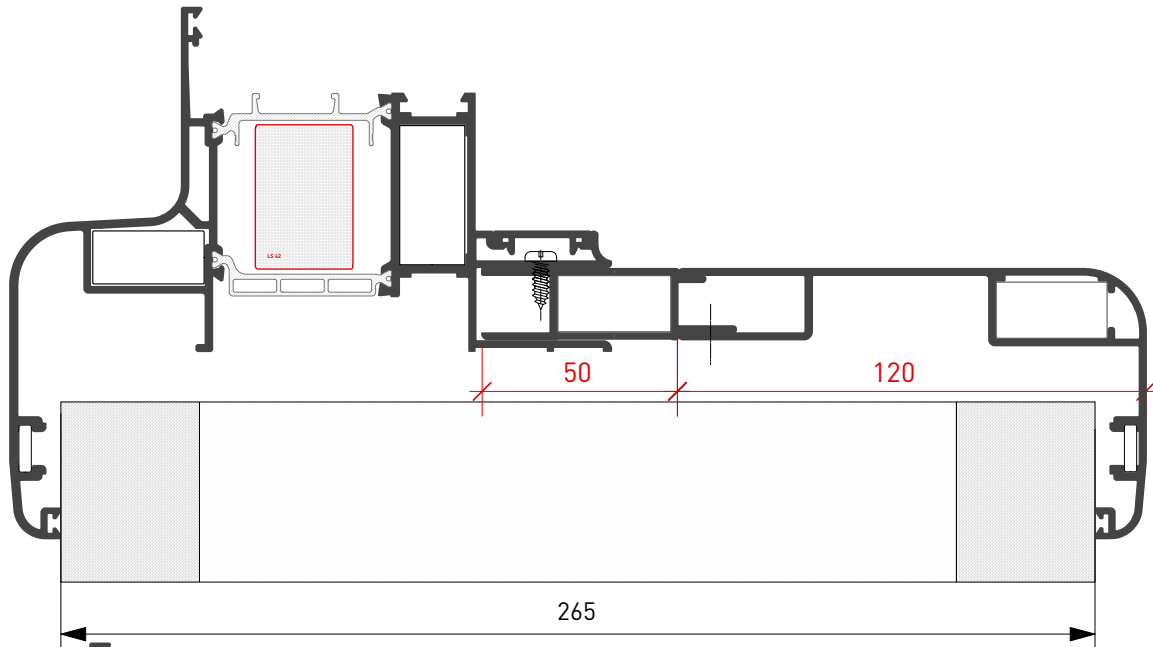
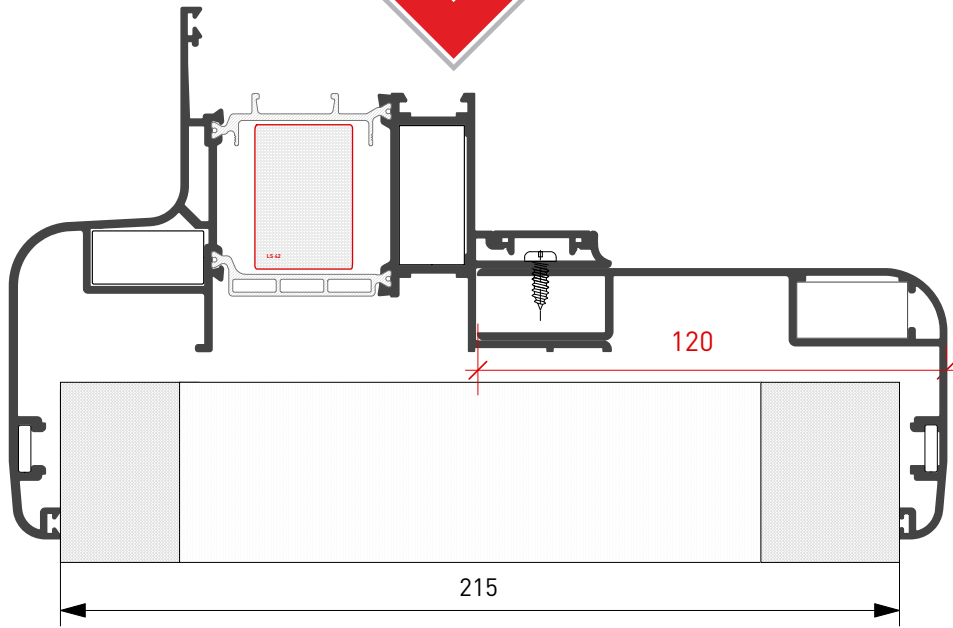

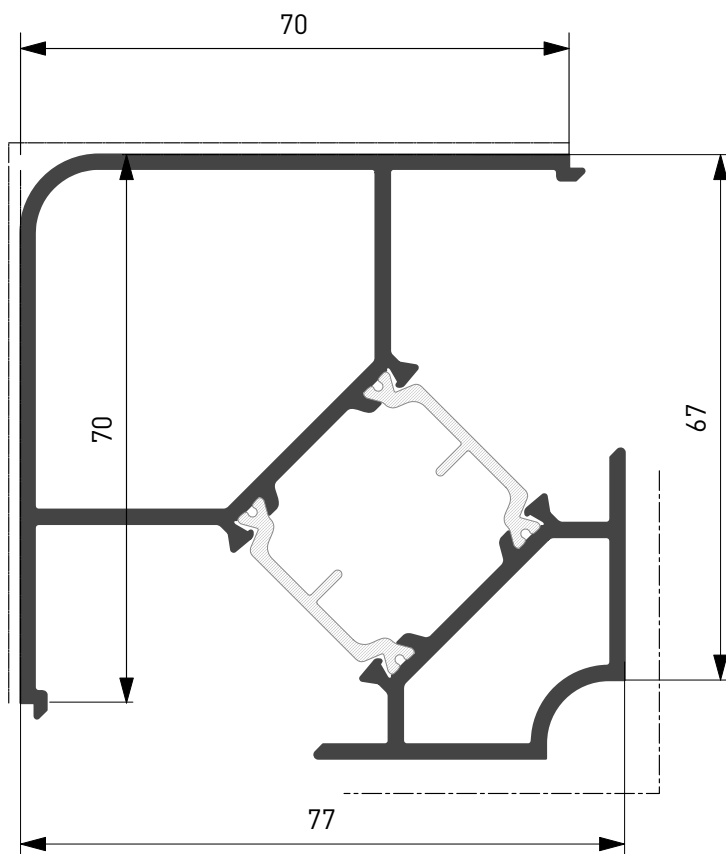

**XX75.613**

Kg/ml 1,877  
--- mm. 215,0

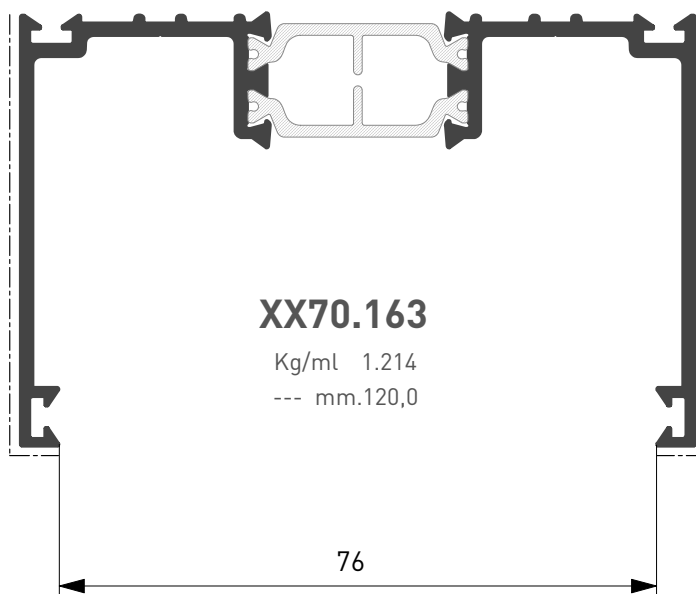

**XX70.163**

Kg/ml 1.214  
--- mm.120,0



**CX70.540**

Kg/ml 0.2249  
--- mm. 32,0

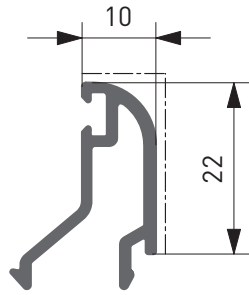

**CX70.521**

Kg/ml 0.266  
--- mm. 36,0

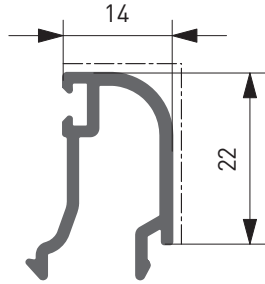

**CX70.522**

Kg/ml 0.277  
--- mm. 40,0

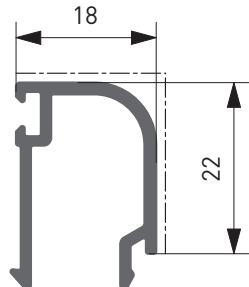

**CX70.523**

Kg/ml 0.294  
--- mm. 44,0

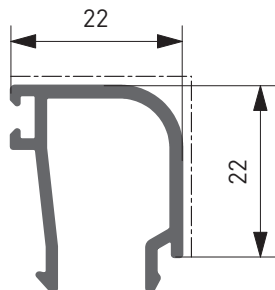

**CX70.524**

Kg/ml 0.314  
--- mm. 48,0

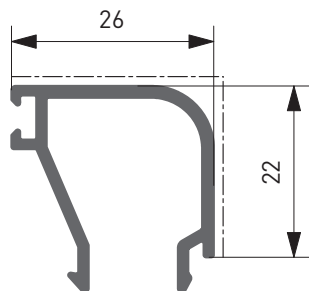

**CX70.525**

Kg/ml 0.350  
--- mm. 52,0

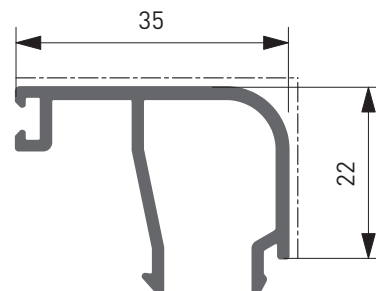
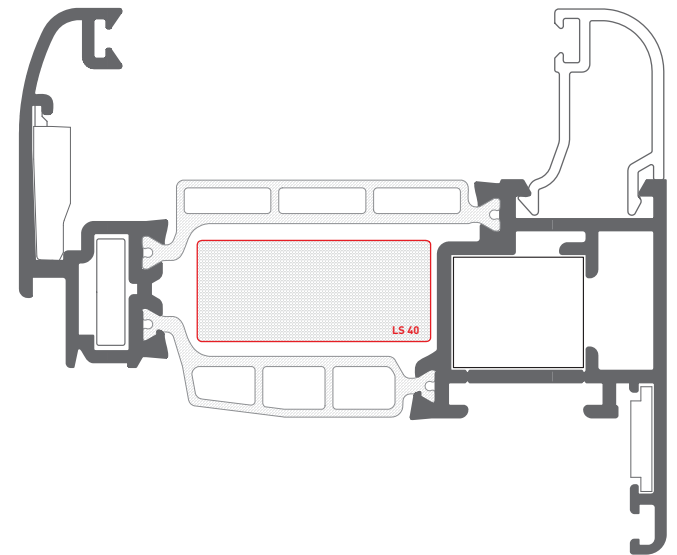
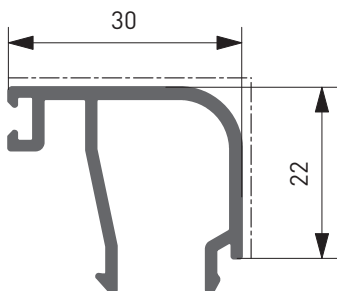

**CX70.531**

Kg/ml 0.370  
--- mm. 57,0



**APPLICAZIONE FERMAVETRI DRITTI**  
**APPLICATION OF STRAIGHT GLAZING BEADS**

**CX70.533**

Kg/ml 0.252  
--- mm. 27,0

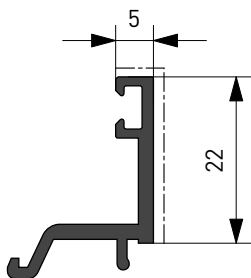

**CX70.539**

Kg/ml 0.245  
--- mm. 27,0

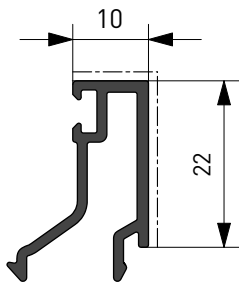

**CX70.526**

Kg/ml 0.279  
--- mm. 36,0

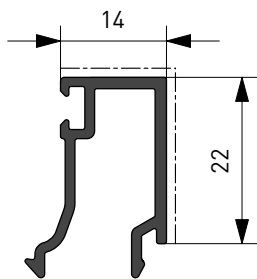

**CX70.527**

Kg/ml 0.290  
--- mm. 40,0

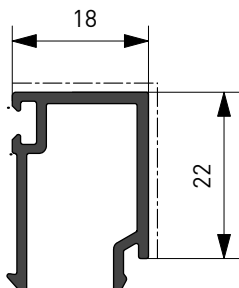

**CX70.528**

Kg/ml 0.307  
--- mm. 44,0

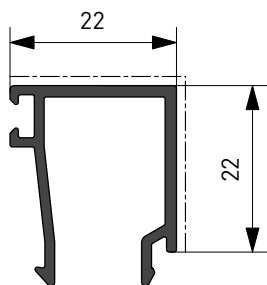

**CX70.529**

Kg/ml 0.327  
--- mm. 48,0

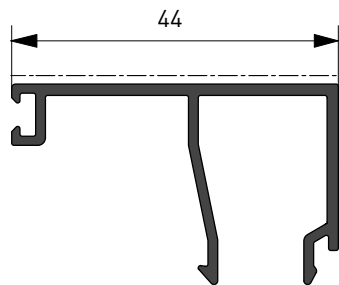
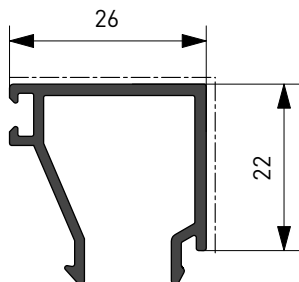

**CX70.541**

Kg/ml 0.418  
--- mm. 66,0

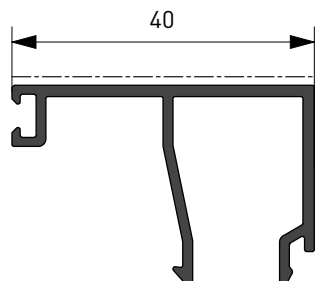

**CX70.537**

Kg/ml 0.403  
--- mm. 62,0

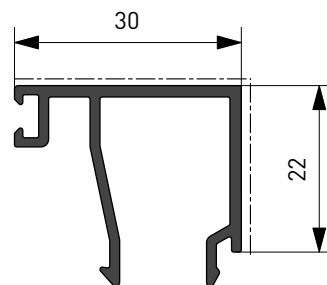

**CX70.530**

Kg/ml 0.362  
--- mm. 52,0

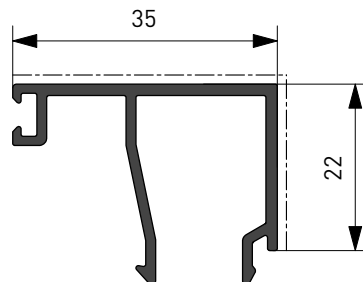

**CX70.532**

Kg/ml 0.383  
--- mm. 57,0

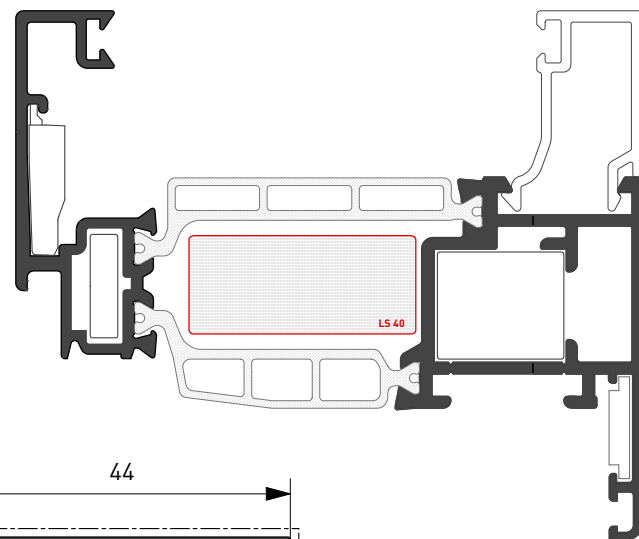



**CX70.571**

Kg/ml 0.216  
--- mm. 36,0

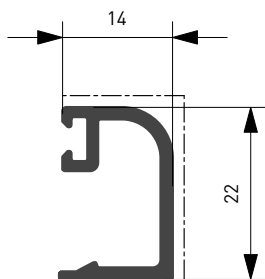

**CX70.572**

Kg/ml 0.262  
--- mm. 40,0

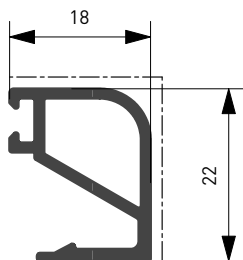

**CX70.573**

Kg/ml 0.283  
--- mm. 44,0

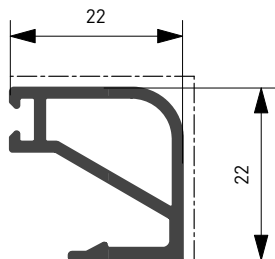

**CX70.574**

Kg/ml 0.313  
--- mm. 48,0

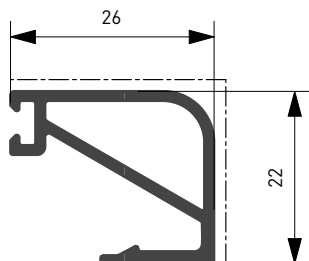

**CX70.575**

Kg/ml 0.340  
--- mm. 52,0

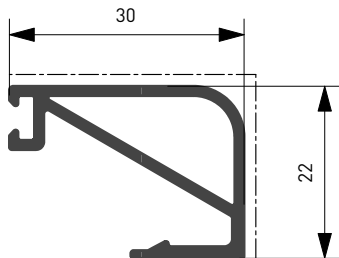

**RX70.581**

Kg/ml 0.361  
--- mm. 57,0

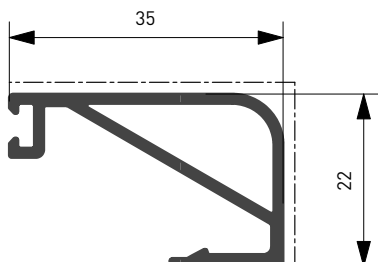

**APPLICAZIONE FERMAVETRI TONDI C/CLIPS**  
**APPLICATION OF ROUND GLAZING BEADS w/CLIPS**

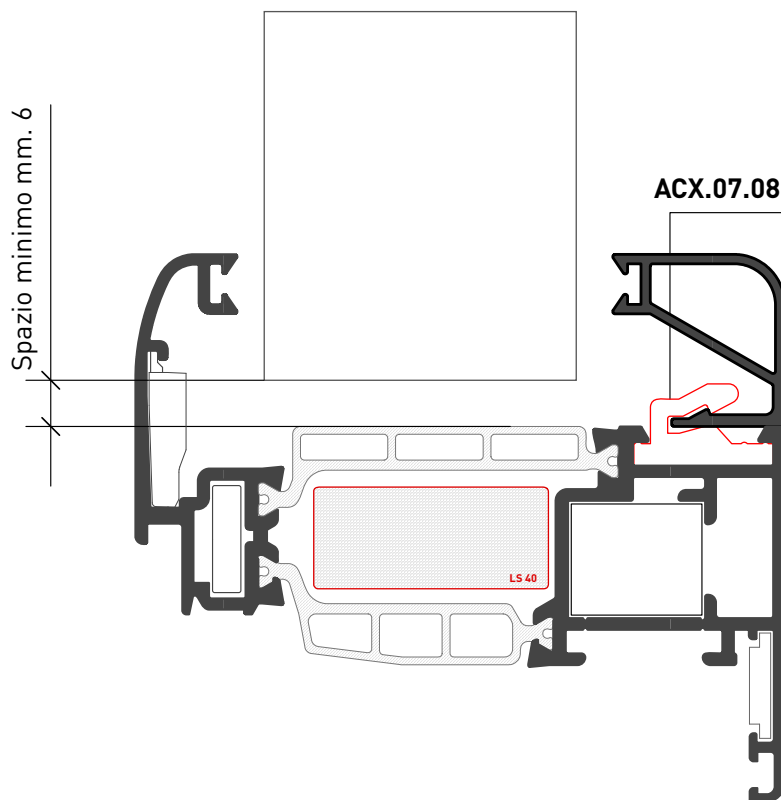

**E' consigliabile l'abbinamento con fermavetri tradizionali tondi con taglio a 45°, al fine di evitare gli angoli fermavetro in zama**

*It is advisable to combine with traditional round glazing beads with a 45° cut, in order to avoid zamac glazing bead corners*



**APPLICAZIONE FERMAVETRI DI SICUREZZA**

**APPLICATION OF SAFETY GLAZING BEADS**

**CX70.568**

Kg/ml 0.297

--- mm. 32,0

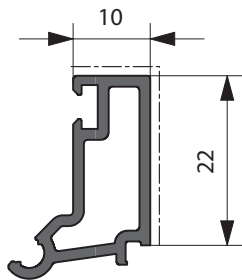

**CX70.562**

Kg/ml 0.324

--- mm. 36,0

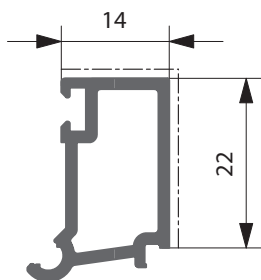

**CX70.563**

Kg/ml 0.330

--- mm. 40,0

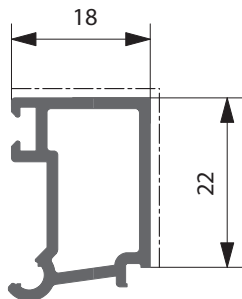

**CX70.564**

Kg/ml 0.348

--- mm. 44,0

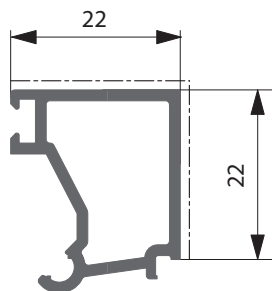

**CX70.565**

Kg/ml 0.372

--- mm. 48,0

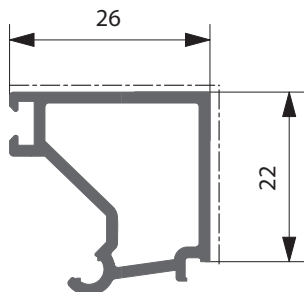

**CX70.566**

Kg/ml 0.396

--- mm. 52,0

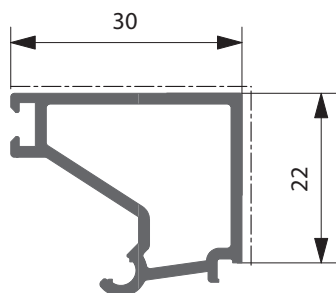

**APPLICAZIONE FERMAVETRI C/CLIPS**

**APPLICATION OF GLAZING BEADS W/CLIPS**

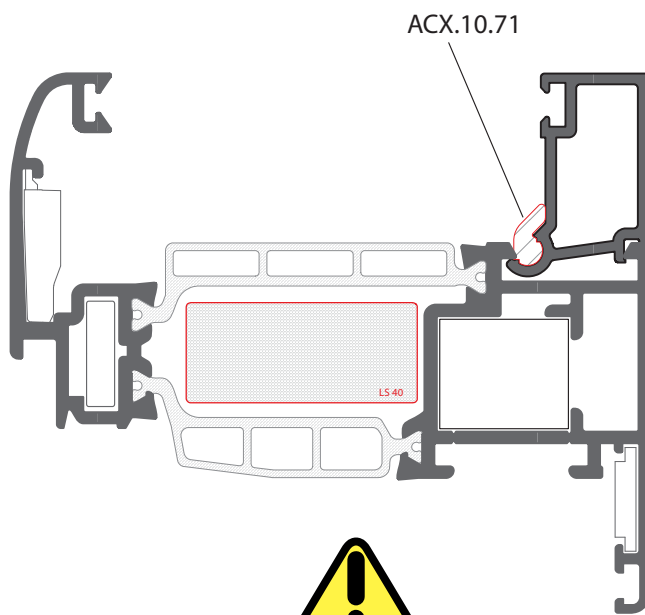

**ATTENZIONE | ATTENTION**

UTILIZZARE UN PEZZO OGNI  
300 mm. (min 2 Pz.)  
CONSIDERARE LA  
GUARNIZIONE INTERNA A  
ZEPPA Min. 4 mm.

• USE ONE PIECE EVERY 300 mm.  
• CONSIDER THE INTERNAL  
WEDGE GASKET Min. 4 mm.

**CX70.567**

Kg/ml 0.434

--- mm. 57,0

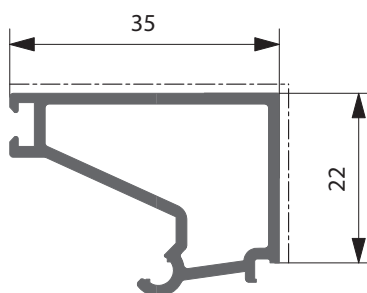

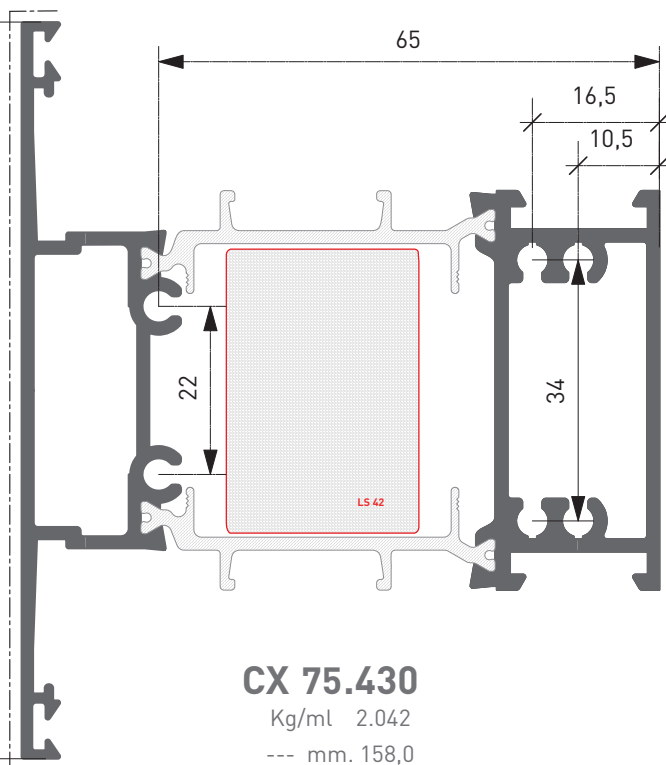
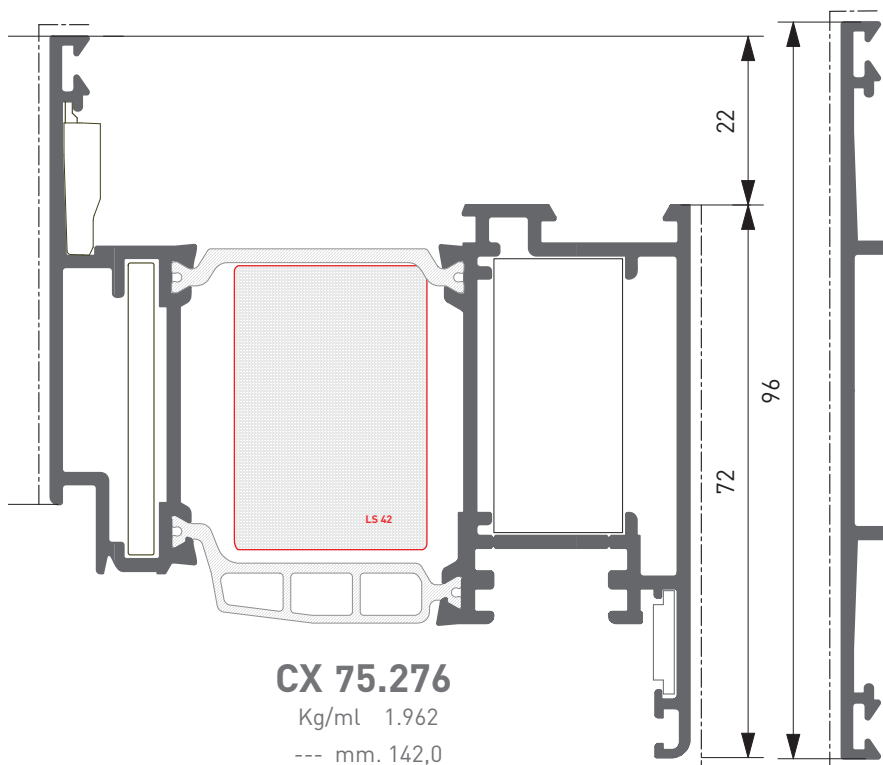
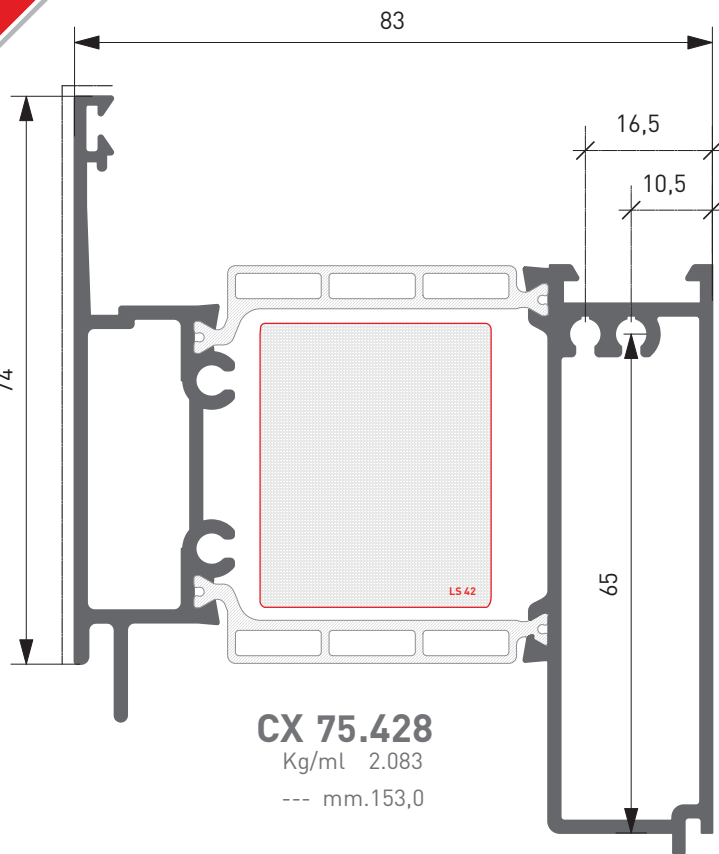
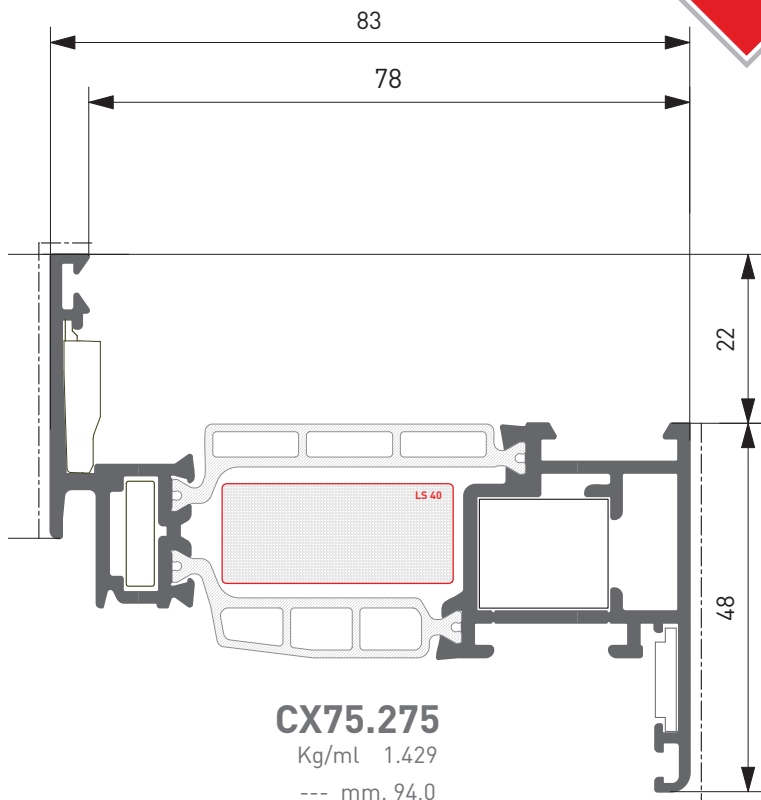

Profilato Profile	Squadretta esterna   External Corner Joint		Squadretta Interna   Internal Corner Joint				Sq. Allineamento   Alining Corner J.	
	Cianfrinare Riveting	Spinare Crimping	Bottone Slot	Cianfrinare Riveting	Spinare Crimping	Avvitare Screw	Esterna External	Interna Internal
CX75.275	ARX.03.SQ	ARX.03.SQ + ARX.08.SQ	ACX.16.SQ		AWX.19.SQ		ARX.15.SQ	ARX.10.SQ
CX75.276	ARX.06.SQ	ARX.06.SQ + ARX.08.SQ			AWX.17.SQ		ARX.15.SQ	ARX.10.SQ

**ATTENZIONE! Per spinatura aggiungere ACX07.SQ | Per avvitatura aggiungere VILM 5x14\_D8 [Gruppo C]**  
**ATTENTION! For crimping add ACX07.SQ | For Screw add VILM 5x14\_D8 [Group C]**

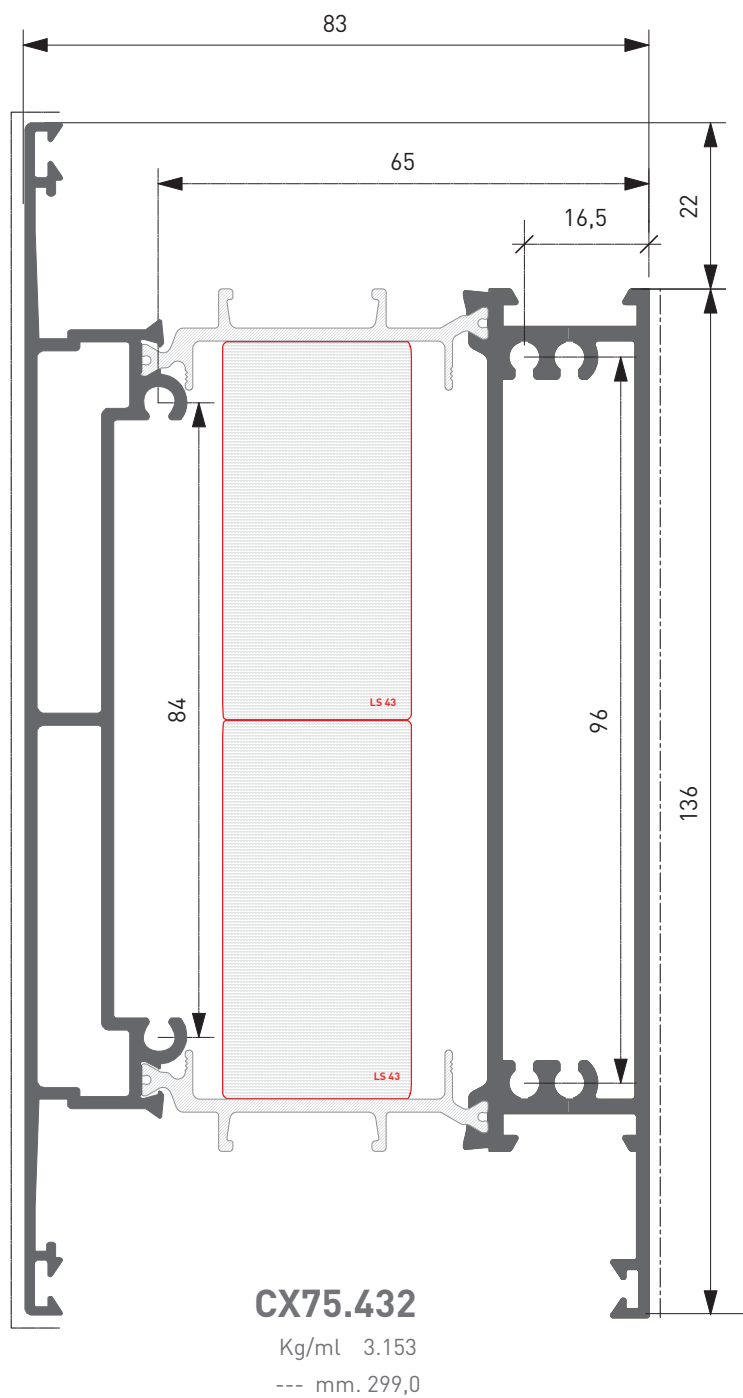
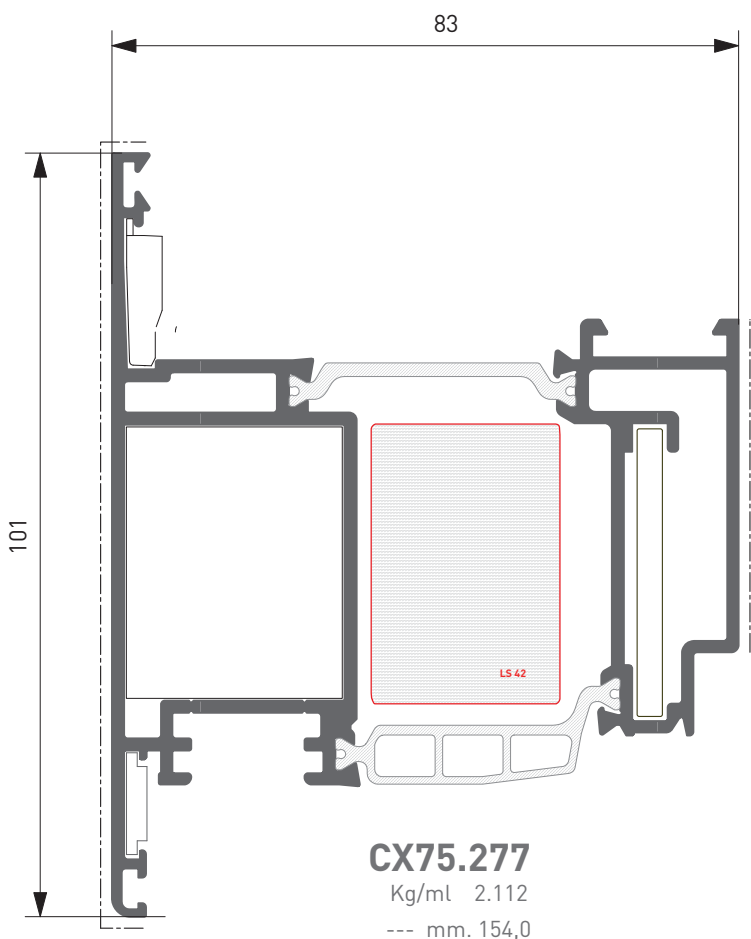
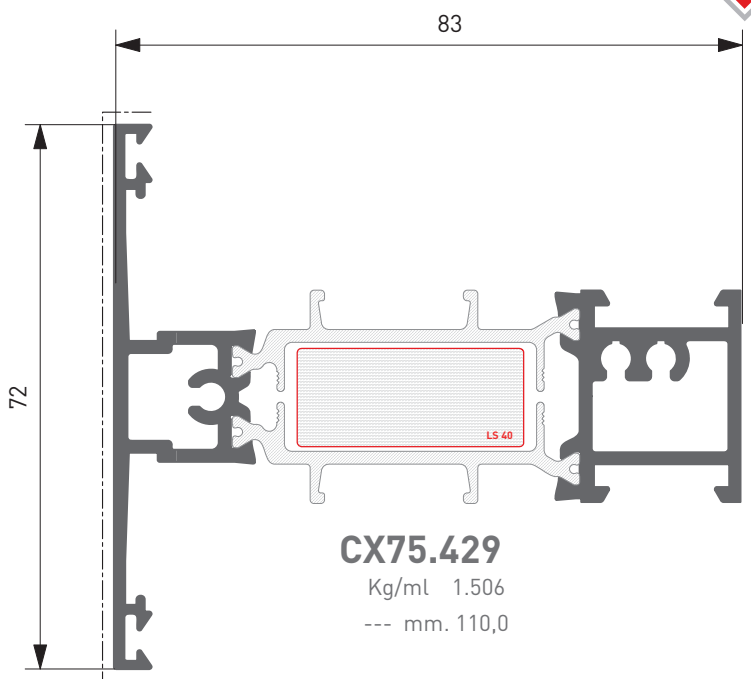

Profilato Profile	Squadretta esterna   External Corner Joint		Squadretta Interna   Internal Corner Joint				Sq. Allineamento   Alining Corner J.	
	Cianfrinare Riveting	Spinare Crimping	Bottone Slot	Cianfrinare riveting	Spinare Crimping	Avvitare Screw	Esterna External	Interna Internal
CX75.277	ARX.06.SQ	ARX.06.SQ + ARX.08.SQ			AWX.17.SQ		ARX.10 e 15.SQ	ARX.09.SQ

**ATTENZIONE! Per spinatura aggiungere ACX07.SQ | Per avvitatura aggiungere VILM 5x14\_D8 [Gruppo C]**  
**ATTENTION! For crimping add ACX07.SQ | For Screw add VILM 5x14\_D8 [Group C]**

**FERRAMENTA A NASTRO**  
**TAPE HARDWARE**

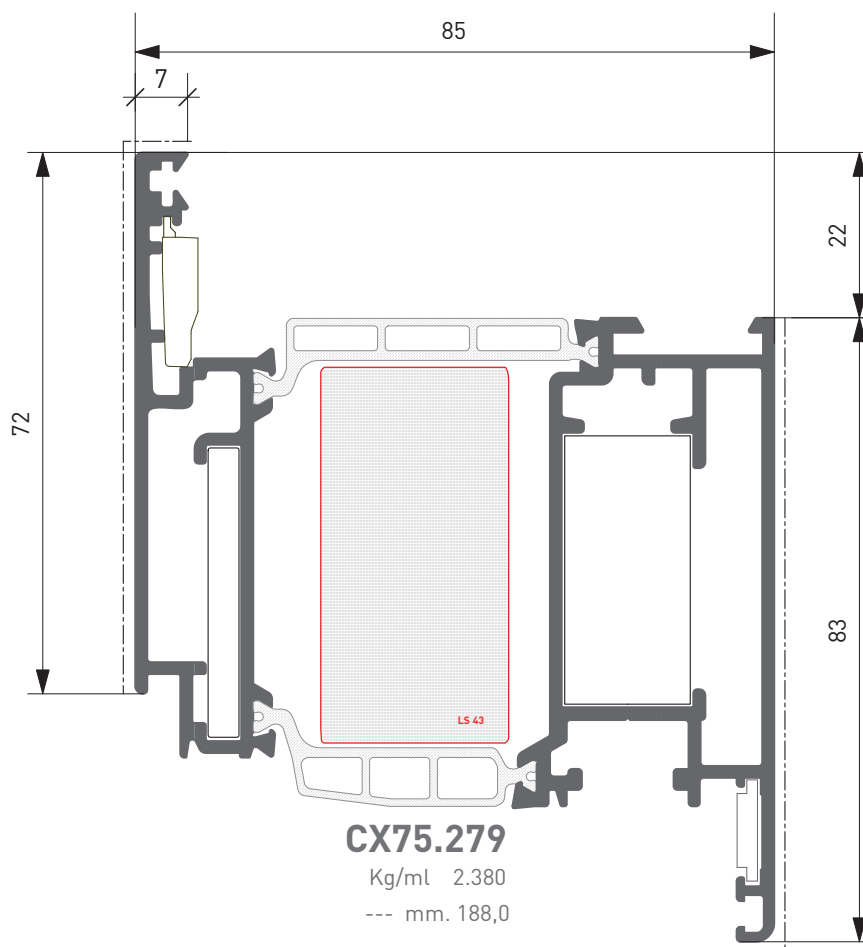
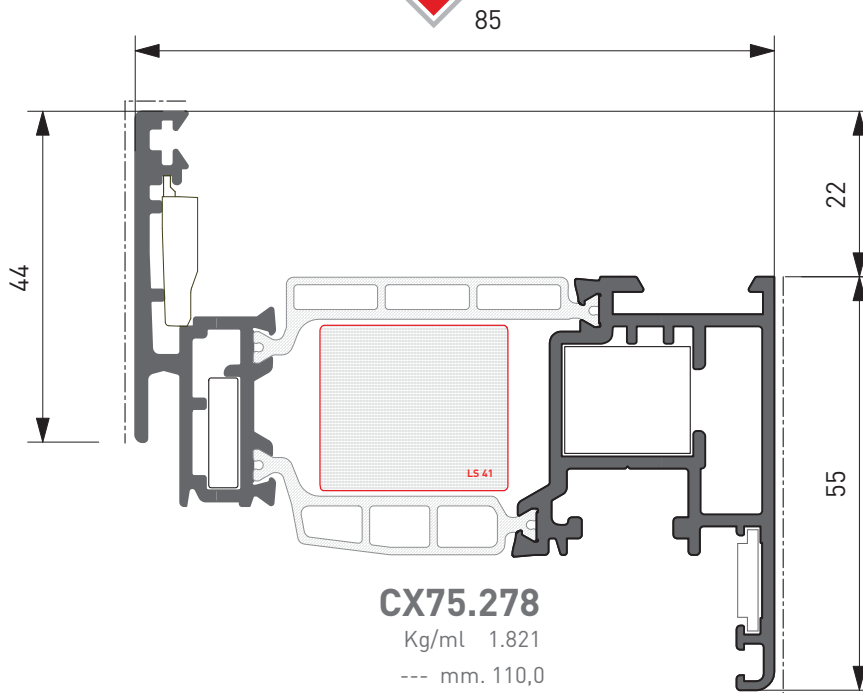

Profilato Profile	Squadretta esterna   External Corner Joint		Squadretta Interna   Internal Corner Joint					Sq. Allineamento   Alining Corner J.	
	Cianfrinare Riveting	Spinare Crimping	Bottone Slot	Cianfrinare Riveting	Spinare Crimping	Avvitare Screw	Esterna External	Interna Internal	
CX75.279	ARX.06.SQ	ARX.06.SQ + ARX.08.SQ			AWX.17.SQ		ARX.15.SQ	ARX.10.SQ	
CX75.278	ARX.03.SQ	ARX.03.SQ + ARX.08.SQ	ACX.16.SQ		AWX.19.SQ		ARX.15.SQ	ARX.10.SQ	

**ATTENZIONE!** Per spinatura aggiungere anche ACX07.SQ | Per avvitatura aggiungere anche VILM 5x14\_D8 [Gruppo C]  
**ATTENTION!** The internal corner joints are Right and Left, see the List of Accessories [Group C]

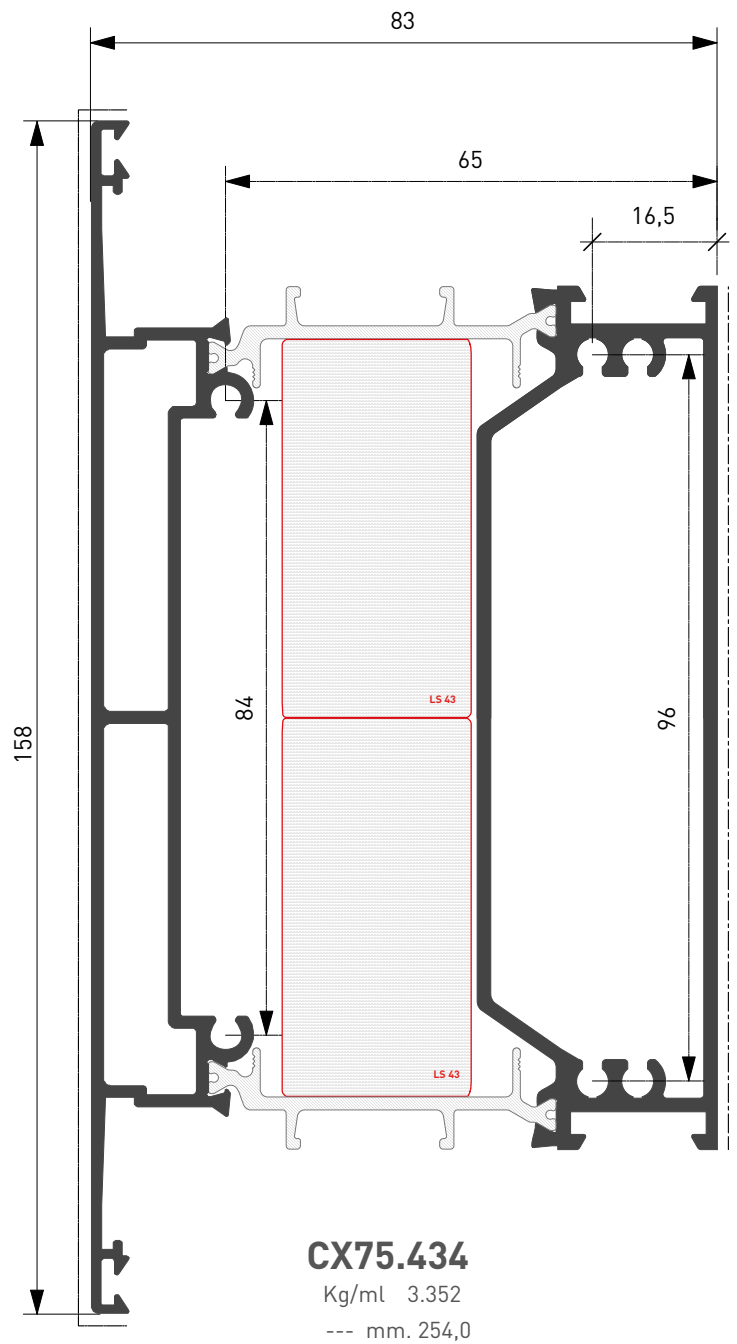
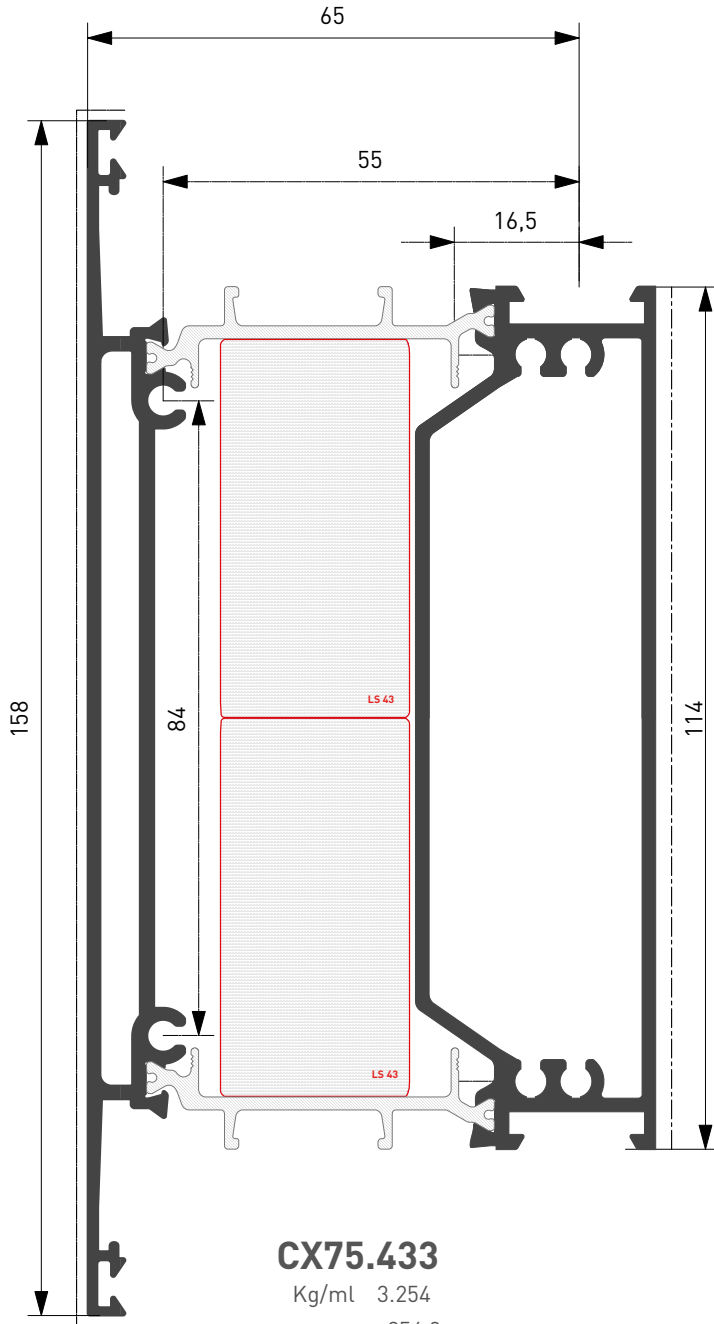



Aletta Flap <b>(a)</b> mm.	Vuoto Gap <b>(v)</b> mm.	Dim. Fermavetro Glazing Bead Size <b>(f)</b> mm.	Codice Fermavetro Glazing Bead CODE	Dim. Guarnizione EXT EXTERNAL Gasket Size mm.	Guarnizioni INTERNE Vetro INTERNAL Glass Window Gaskets								
					ARX.10.15		ARX.10.14		ARX.10.13		ARX.10.12		
					mm.10	mm.9	mm.8	mm.7	mm.6	mm.5	mm.4	mm.3	
5	35	35	D	CX70.532	3	22	23	24	25	26	27	28	29
			T	CX70.531									
5	40	30	D	CX70.530	3	27	28	29	30	31	32	33	34
			T	CX70.525									
5	44	26	D	CX70.529	3	31	32	33	34	35	36	37	38
			T	CX70.524									
5	48	22	D	CX70.528	3	35	36	37	38	39	40	41	42
			T	CX70.523									
5	52	18	D	CX70.527	3	39	40	41	42	43	44	45	46
			T	CX70.522									
5	56	14	D	CX70.526	3	43	44	45	46	47	48	49	50
			T	CX70.521									
5	65	5	D	CX70.533	3	52	53	54	55	56	57	58	59
			T										

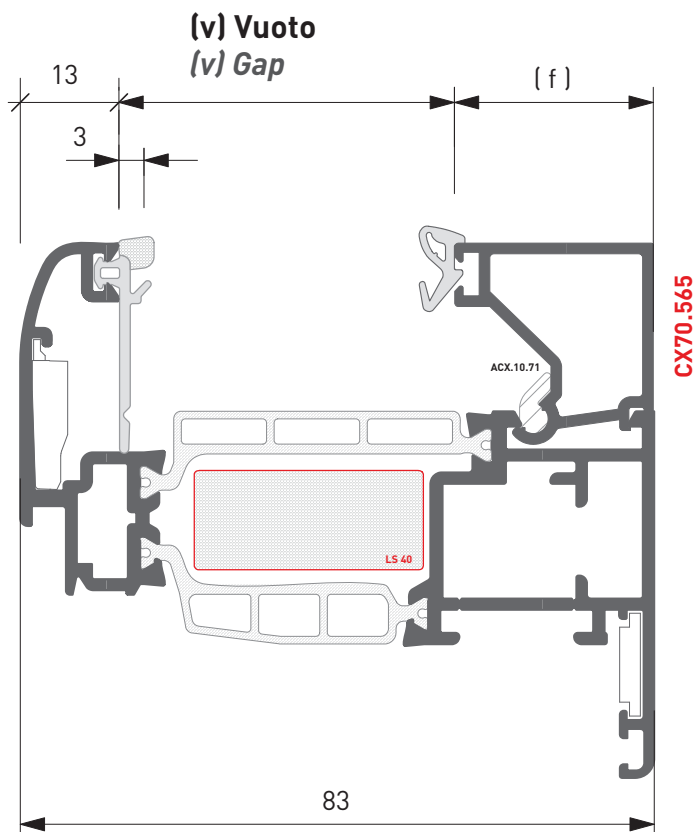
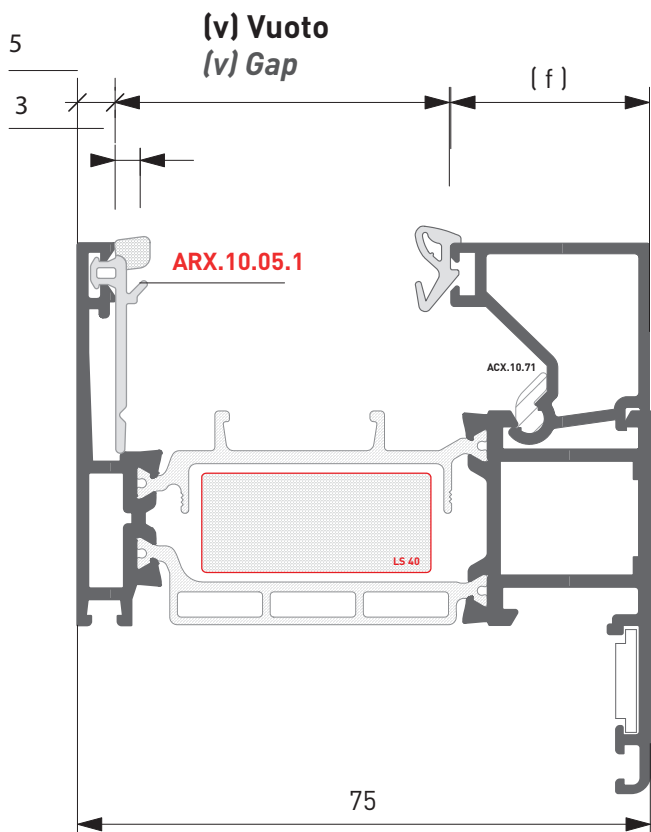



**TASSELLI VETRO PER TIPOLOGIA**  
**GLASS DOWELS FOR TYPE**

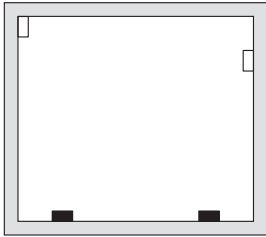

**Telaio Fisso**  
*Fixed Frame*

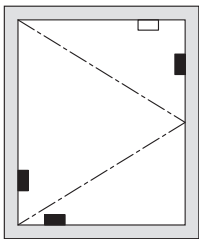

**Anta Battente**  
*Casement Window*

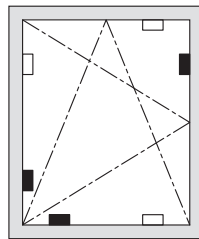

**Anta Ribalta**  
*Csement+Protruding Window*

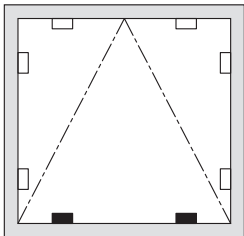

**Wasistas**  
*Protruding Window*

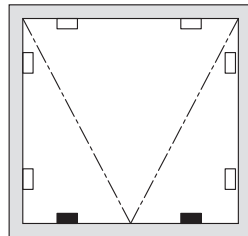

**Sporgere**  
*Transom Window*

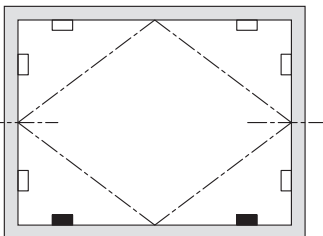

**Bilico Orizzontale**  
*Horizontal Pivoting Window*

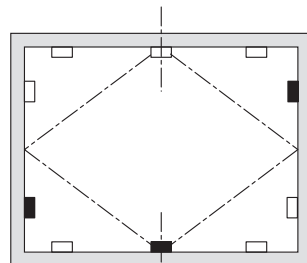

**Bilico Verticale**  
*Vertical Pivoting Window*

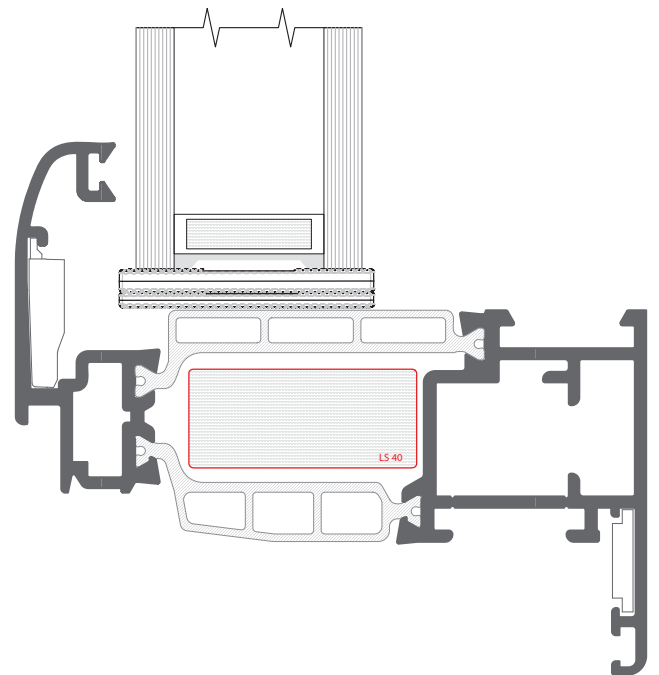

**TASSELLO di APPOGGIO**  
*SUPPORTING PLUG*

**TASSELLO PERIMETRALE**  
*PERIMETER PLUG*





Accessori e Guarnizioni  
*Accessories and Gaskets*

Gruppo **C**

Elenco accessori | *List of Accessories*  
Elenco guarnizioni | *List of Window Gaskets*

**CODIFICA FINITURE SUPERFICIALI ACCESSORI**  
**ACCESSORIES SURFACE FINISHING CODES**

In fase di ordine aggiungere agli accessori, se previste, le seguenti codifiche superficiali:  
When ordering, add the following surface codes to the accessories listed below, where applicable:

<b>DESCRIPTION</b>	<b>CODICE CODE</b>	<b>DESCRIZIONE</b>
<b>PAINTED MATT BLACK</b>	<b>NEOPA</b>	VERNICIATO NERO OPACO
<b>WHITE</b>	<b>R 9 0 1 0</b>	VERNICIATO BIANCO
<b>IVORY</b>	<b>R 1 0 1 3</b>	VERNICIATO AVORIO
<b>GREEN</b>	<b>R 6 0 0 5</b>	VERNICIATO VERDE
<b>BLACK</b>	<b>R 9 0 0 5</b>	VERNICIATO NERO LUCIDO
<b>BROWN</b>	<b>R 8 0 1 7</b>	VERNICIATO MARRONE
<b>GOTHIC GREEN</b>	<b>G 6 3 6 0</b>	VERNICIATO VERDE GOTICO
<b>GOTHIC GREY</b>	<b>G 9 4 2 0</b>	VERNICIATO GRIGIO GOTICO
<b>GOTHIC BROWN</b>	<b>G 3 9 7 6</b>	VERNICIATO MARRONE GOTICO
<b>SILVER</b>	<b>V E A R</b>	VERNICIATO ARGENTO
<b>WITHERED MOSS</b>	<b>V S C R A</b>	VERDE SCURO RAGGRINZITO
<b>FALLOW</b>	<b>M A R A G</b>	MARRONE RAGGRINZITO
<b>GOLDFINISH GUNMETAL GRAY</b>	<b>K A N F U</b>	CANNA DI FUCILE GOLDFINISH
<b>GOLDFINISH COPPER</b>	<b>K R A M E</b>	RAME GOLDFINISH
<b>GOLDFINISH POLISHED</b>	<b>K I N O X</b>	INOX LUCIDO GOLDFINISH
<b>GOLDFINISH SATIN-FINISH STAINLESS STEEL</b>	<b>K S A T I</b>	INOX SATINATO GOLDFINISH
<b>GOLDFINISH GOLD</b>	<b>K G O L D</b>	GOLD GOLDFINISH
<b>GOLDFINISH ANTIQUE BRASS</b>	<b>K A N T I C</b>	OTTONE ANTICO GOLDFINISH
<b>NEW SILVER</b>	<b>A R G E N T</b>	NEW ARGENTO
<b>NEW BRONZE</b>	<b>B R O N Z</b>	NEW BRONZO

**ESEMPIO****ARX 02.01 | R 9010****EXAMPLE****Cerniera Verniciata | COLORE Bianco Ral 9010**  
**Painted Hinge | COLOUR White RAL 9010**



<p><b>ARX.03.SQ</b></p> <p>Descrizione <i>Description</i> <b>Squadretta cianfrinare/spinare</b> <i>Riveting/crimping Corner Joint</i> (4.3 mm. x 14 mm.)</p>		<p><b>AWX.17.SQ</b></p> <p>Descrizione <i>Description</i> <b>Squadretta avvitare/cianfrinare/spinare</b> <i>Screwing/Riveting/crimping Corner Joint</i> (17.5 mm. x 35.8 mm.)</p>	 <p>VIL M5X14_D8 Vite per squadretta <i>Corner Joint Screw</i></p>
<p><b>ARX.06.SQ</b></p> <p>Descrizione <i>Description</i> <b>Squadretta cianfrinare/spinare</b> <i>Riveting/crimping Corner Joint</i> (4.3 mm. x 39.1 mm.)</p>		<p><b>ARX.18.SQ</b></p> <p>Descrizione <i>Description</i> <b>Squadretta cianfrinare/spinare</b> <i>Riveting/crimping Corner Joint</i> (4.3 mm. x 26.3 mm.)</p>	
<p><b>ARX.07.SQ</b></p> <p>Spina per ACX.02.SQ e ACX.14.SQ <i>Plug</i></p> <p><b>ARX.08.SQ</b></p> <p>Spina per ACX.03.SQ e ACX.06.SQ <i>Plug</i></p>	  	<p><b>AWX.19.SQ</b></p> <p>Descrizione <i>Description</i> <b>Squadretta avvitare/cianfrinare/spinare</b> <i>Screwing/Riveting/crimping Corner Joint</i> (17.5 mm. x 15 mm.)</p>	 <p>VIL M5X14_D8 Vite per squadretta <i>Corner Joint Screw</i></p>
<p><b>ARX.10.SQ</b></p> <p>Descrizione <i>Description</i> <b>Squadretta allineamento interna</b> <i>Internal Alining Corner Joint</i></p>		<p><b>ARX.24.SQ</b></p> <p>Descrizione <i>Description</i> <b>Squadretta allineamento esterna</b> <i>External Alining Corner Joint</i></p>	
<p><b>ARX.11.SQ</b></p> <p>Descrizione <i>Description</i> <b>Squadretta allineamento EXT</b> <i>External Alining Corner Joint</i> <b>XX70.801 e RX60.109</b></p>		<p><b>ACX.47.SQ</b></p> <p>Descrizione <i>Description</i> <b>Cavalotto fermavetri dritti</b> <b>nessuna lavorazione</b> <i>External U-bolt w/straight glazing bead</i> (portata 350 kg.)</p>	
<p><b>ARX.13.SQ</b></p> <p>Descrizione <i>Description</i> <b>Squadretta a pulsante</b> <i>Slot Corner Joint</i> (23.5 mm. x 14.5 mm.)</p>		<p><b>ACX.48.SQ</b></p> <p>Descrizione <i>Description</i> <b>Squadretta angolo variabile</b> <i>Variable Corner Joint</i> (16.8 mm. x 14.3 mm.)</p>	 <p>dx - sx L - R</p>
<p><b>ARX.14.SQ</b></p> <p>Descrizione <i>Description</i> <b>Squadretta cianfrinare/spinare/avvitare</b> <i>Riveting/crimping Corner Joint</i> (28.5 mm. x 35.8 mm.)</p>		<p><b>ARX.58.SQ</b></p> <p>Descrizione <i>Description</i> <b>Squad. allineam. ante   FASCIA</b> <i>T-joint alignment for sash</i> Rientro 13 mm.</p>	
<p><b>ARX.15.SQ</b></p> <p>Descrizione <i>Description</i> <b>Squad. allineamento EXT</b> <b>tiraggio meccanico</b> <i>External alining Corner Joint</i> <i>mechanical draught</i></p>		<p><b>ARX.71.SQ</b></p> <p>Descrizione <i>Description</i> <b>Squad. allineam. capannoni</b> <i>External alignment corner joint</i> (40 mm. x 3 mm.)</p>	
<p><b>ACX.16.SQ</b></p> <p>Descrizione <i>Description</i> <b>Squadretta a pulsante</b> <i>Slot Corner Joint</i> (17.5 mm. x 15 mm.) Pulsante (Button) 8 mm.</p>		<p><b>ACX.72.SQ</b></p> <p>Descrizione <i>Description</i> <b>Squadretta a pulsante</b> <i>Slot Corner Joint</i> (35.9 mm. x 14.7 mm.) Pulsante (Button) 8 mm.</p>	



<p><b>ACX.73.SQ</b></p> <p>Descrizione <i>Description</i> Squad. allineam. Alignment corner joint (46. mm. x 1.2 mm.)</p>		<p><b>ACX.02.06</b></p> <p>Descrizione <i>Description</i> Cerniera per vasistas apertura doppia 30° e 75° Long arm for wasistas window</p>	
<p><b>VIL M5X14_D8</b></p> <p>Descrizione <i>Description</i> Vite per squadretta Screw for Corner Joint AWX.17.SQ e AWX.19.SQ</p>		<p><b>ACX.02.07</b></p> <p>Descrizione <i>Description</i> Braccio lungo per vasistas Short arm for wasistas window Anta/Sash=600/1600 mm.</p>	
<p><b>ACX.63.SQ</b></p> <p>Descrizione <i>Description</i> Giunzione a "T" o a "Croce" "T" or "Cross" junction H = 14.4</p>		<p><b>ACX.02.08</b></p> <p>Descrizione <i>Description</i> Braccio corto per vasistas Anta/Sash=280/800 mm.</p>	
<p><b>ACX.64.SQ</b></p> <p>Descrizione <i>Description</i> Giunzione a "T" o a "Croce" "T" or "Cross" junction H = 34.8 Pulsante[Button] 8 mm</p>		<p><b>ACX.02.09</b></p> <p>Descrizione <i>Description</i> Braccio telescopico per vasistas a scatto Telescopic arm for snap-fit wasistas window</p>	
<p><b>ACX.02.01</b></p> <p>Descrizione <i>Description</i> Cerniera a montaggio rapido preassemblata a 2 ali Rapid-assembly pre-assembled 2-leafed hinge for 3rd Sash</p>		<p><b>ACX.02.10</b></p> <p>Descrizione <i>Description</i> Cerniera a compasso Compass Hinge</p>	
<p><b>ACX.02.02</b></p> <p>Descrizione <i>Description</i> Cerniera a montaggio rapido preassemblata a 2 ali per 3° anta Rapid-assembly pre-assembled 3-leafed hinge</p>		<p><b>ACX.02.10P</b></p> <p>Descrizione <i>Description</i> Cerniera Scomparsa Concealed Hinge Battente Casement 40 kg Sporgere Projection 120 kg Wasistas Wasistas 120 kg</p>	
<p><b>ACX.02.03</b></p> <p>Descrizione <i>Description</i> Cerniera a montaggio rapido preassemblata a 3 ali Rapid-assembly pre-assembled 3-leafed hinge for 3rd Sash</p>		<p><b>ACX.02.11</b></p> <p>Descrizione <i>Description</i> Cerniera a 2 ali per porte con piastrina ad infilare 2-leafed hinge for doors with plate to insert</p>	
<p><b>ACX.02.04</b></p> <p>Descrizione <i>Description</i> Cerniera a montaggio rapido preassemblata a 3 ali per 3° anta Hinge for single opening wasistas window 30°</p>		<p><b>ARX.02.12</b></p> <p>Descrizione <i>Description</i> Cerniera per Porta EXT 2 Ali 2-leafed hinge for External doors Interasse/Center Dist.= 67 mm.</p>	
<p><b>ACX.02.05</b></p> <p>Descrizione <i>Description</i> Cerniera per vasistas apertura singola 30° Hinge for double opening wasistas window 30°/75°</p>		<p><b>ARX.02.13</b></p> <p>Descrizione <i>Description</i> Cerniera per Porta EXT 3 Ali 3-leafed hinge for External doors Interasse/Center Dist.= 67 mm.</p>	

















<p><b>ARX.02.14</b></p> <p>Descrizione <i>Description</i> <b>Cerniera per Porta EXT 2 Ali</b> 2-leafed hinge for External doors Interasse/Center Dist.= 93 mm.</p>		<p><b>ARX.02.37</b></p> <p>Descrizione <i>Description</i> <b>Regolatore in altezza</b> Height Adjuster Cerniere/Hinges=ARX.02.11</p>	
<p><b>ARX.02.15</b></p> <p>Descrizione <i>Description</i> <b>Cerniera per Porta EXT 3 Ali</b> 3-leafed hinge for External doors Interasse/Center Dist.= 93 mm.</p>		<p><b>ACX.03.01</b></p> <p>Descrizione <i>Description</i> <b>Cricchetto in alluminio</b> Fissaggio Con Piastrine Plate fixing aluminium ratchet</p>	
<p><b>ARX.02.16</b></p> <p>Descrizione <i>Description</i> <b>Spessore per Cerniera Porta EXT</b> Spacer for EXT Door Hinge Spessore/Thickness= 8 mm.</p>		<p><b>ARX.03.02</b></p> <p>Descrizione <i>Description</i> <b>Maniglia a Tavellino</b> Tavellino HANDLE</p>	
<p><b>ARX.02.17</b></p> <p>Descrizione <i>Description</i> <b>Cerniera per scuretto</b> Hinge for Shutter</p>		<p><b>ARX.03.03</b></p> <p>Descrizione <i>Description</i> <b>Maniglia Doppia</b> Double Hinge</p>	
<p><b>ARX.02.21</b></p> <p>Descrizione <i>Description</i> <b>Kit Contropiastrine cerniere 2 Ali</b> 2-leafed hinge strike plates kit</p>		<p><b>ASX.03.03</b></p> <p>Descrizione <i>Description</i> <b>Martellina Doppia</b> Double Martellina Handle COMFORT</p>	
<p><b>ARX.02.22</b></p> <p>Descrizione <i>Description</i> <b>Kit Contropiastrine cerniere 3 Ali</b> 3-leafed hinge strike plates kit</p>		<p><b>ARX.03.04</b></p> <p>Descrizione <i>Description</i> <b>Martellina</b> MARTELLINA Handle Rosette Projection=24 mm.</p>	
<p><b>ARX.02.23</b></p> <p>Descrizione <i>Description</i> <b>Perni fissaggio cerniere</b> Hinge Fixing Pins 68 mm.</p>		<p><b>ARX.03.05</b></p> <p>Descrizione <i>Description</i> <b>Martellina con chiave</b> MARTELLINA Handle w/Key Sporg. Quadro/Rosette Projection=24 mm.</p>	
<p><b>ARX.02.24</b></p> <p>Descrizione <i>Description</i> <b>Viti di Fissaggio cerniere</b> Hinge Fixing Screws</p>		<p><b>ARX.03.05L</b></p> <p>Descrizione <i>Description</i> <b>Martellina LOGICA dx</b> RIGHT MARTELLINA Handle LOGICA Sporg. Quadro/Rosette Projection=24 mm.</p>	
<p><b>ARX.02.25</b></p> <p>Descrizione <i>Description</i> <b>Kit gradino</b> Step KIT</p>		<p><b>ARX.03.06</b></p> <p>Descrizione <i>Description</i> <b>Cremonese</b> CREMONESE Handle Sporg. Quadro/Center Dist. 84/92/104 mm.</p>	



<p><b>ARX.03.07</b></p> <p>Descrizione <i>Description</i> Cremonese con chiave CREMONESE Handle w/Key</p> <p>Interasse/Center Dist.=84/92/104 mm.</p>		<p><b>ACX.03.17</b></p> <p>Descrizione <i>Description</i> Innesti Cremonese CREMONESE Connections</p>	
<p><b>ARX.03.07L</b></p> <p>Descrizione <i>Description</i> Cremonese LOGICA dx RIGHT CREMONESE Handle LOGICA</p> <p>Interasse/Center Dist.=84/92/104 mm.</p>		<p><b>ACX.03.18</b></p> <p>Descrizione <i>Description</i> Terminali astina Bar Terminals</p>	
<p><b>ARX.03.08</b></p> <p>Descrizione <i>Description</i> Cremonese per Anta Ribalta Cremonese for Tilt&amp;Turn Window</p> <p>Interasse/</p>		<p><b>ACX.03.19</b></p> <p>Descrizione <i>Description</i> Sostegno anta Sash Support</p>	
<p><b>ARX.03.09</b></p> <p>Descrizione <i>Description</i> Movimentazione Bidirezionale Bi-directional movement</p> <p>Interasse/Center Dist.=15/27 mm.</p>		<p><b>ARX.03.22</b></p> <p>Descrizione <i>Description</i> Kit Fast Out chiusura apert. EXT Fast Out EXT Open/Close L=1000 mm. (3 punti) (3 points) E=35 mm.</p>	
<p><b>ACX.03.10</b></p> <p>Descrizione <i>Description</i> Movimentazione Unidirezionale per Anta Ribalta Unidirectional movement for Tilt&amp;Turn Window</p>		<p><b>ARX.03.23</b></p> <p>Descrizione <i>Description</i> Kit Fast Out chiusura apert. EXT Fast Out EXT Open/Close L=600 mm. (2 punti) (2 points) E=35 mm.</p>	
<p><b>ACX.03.12</b></p> <p>Descrizione <i>Description</i> Terminale asta Bar Terminal</p>		<p><b>ARX.03.24</b></p> <p>Descrizione <i>Description</i> Kit Fast Out chiusura apert. EXT Fast Out EXT Open/Close L=1600 mm. (3 punti) (3 points) E=35 mm.</p>	
<p><b>ACX.03.14</b></p> <p>Descrizione <i>Description</i> Incontro Asta Doppio Double Bar Rest Plate</p>		<p><b>ARX.03.XX</b></p> <p>Descrizione <i>Description</i> Kit Fast Out chiusura apert. EXT Fast Out EXT Open/Close</p>	
<p><b>ACX.03.15</b></p> <p>Descrizione <i>Description</i> Ferma Anta Door Stop</p>		<p><b>ARX.03.25</b> art. ARX.03.22</p> <p><b>ARX.03.26</b> art. ARX.03.23</p> <p><b>ARX.03.27</b> art. ARX.03.24</p>	
<p><b>ACX.03.16</b></p> <p>Descrizione <i>Description</i> Perno di chiusura supplementare regolabile Supplementary adjustable closing pin</p>		<p><b>ARX.03.28</b></p> <p>Descrizione <i>Description</i> Martellina per Fast Out FAST OUT MARTELLINA</p> <p>Sporg. Quadro/Rosette Projection=64 mm.</p>	











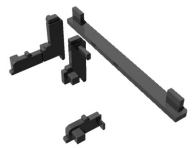

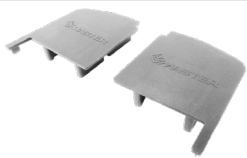

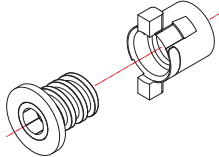

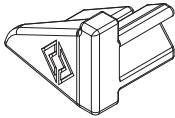
<p><b>ACX.03.29</b></p> <p>Rostro chiusura supplementare Supplementary closing bolt</p>		<p><b>ACX.03.53</b></p> <p>Descrizione Description Martellina "ITALIA" cassa 100mm Martellina Handle "ITALIA" case 100mm</p>	
<p><b>ARX.03.30</b></p> <p>Tavellino per profilo scuretto Latch for Shutter</p>		<p><b>ACX.03.54</b></p> <p>Descrizione Description Sirio terminale asta c/Puntale [Ottone] SIRIO Bar Terminal w/Tip [Brass] Decentr DX   Off Center R <math>\varnothing</math> 8 mm.</p>	
<p><b>ACX.03.43</b></p> <p>POLYAMIDE Bar Astina in poliammide</p>		<p><b>ACX.03.55</b></p> <p>Descrizione Description Sirio terminale asta c/Puntale [Ottone] SIRIO Bar Terminal w/Tip [Brass] Decentr SX   Off Center R <math>\varnothing</math> 8 mm.</p>	
<p><b>ARX.03.45</b></p> <p>Descrizione Description Perno trascinamento Winding Pivot L= 22 mm.</p>		<p><b>ACX.03.56</b></p> <p>Descrizione Description Sirio terminale asta c/Puntale [Ottone] SIRIO Bar Terminal w/Tip [Brass] <math>\varnothing</math> 8 mm.</p>	
<p><b>ARX.03.46</b></p> <p>Descrizione Description Cremonese con chiave CREMONESE Handle w/cylinder Lock</p>		<p><b>ACX.03.57</b></p> <p>Descrizione Description Cremonese ITALIA CREMONESE Italia Bolt In Interasse/Center Dist.=84.5/104 mm.</p>	
<p><b>ARX.03.47</b></p> <p>Descrizione Description Perno trascinamento Winding Pivot L= 13 mm.</p>		<p><b>ACX.03.58</b></p> <p>Descrizione Description ANTIEFFRAZIONE Antibreakage Kit base per Chiusura Closing Accessories Base Kit</p>	
<p><b>ARX.03.48</b></p> <p>Descrizione Description Cremonese apertura EXT c/chave CREMONESE Handle EXT Op. w/cylinder Lock</p>		<p><b>ACX.03.59</b></p> <p>Descrizione Description Cremonese ITALIA per AR con anti falsa manovra for AR wrong counter-actuation</p>	
<p><b>ARX.03.50</b></p> <p>Descrizione Description Cremonese apertura EXT CREMONESE Handle EXT Opening</p>		<p><b>ACX.03.60</b></p> <p>Descrizione Description ANTIEFFRAZIONE Antibreakage Punto chiusura / Closure Lav Astina Tondal Round Bar Tooling <math>\varnothing</math> 8 mm.</p>	
<p><b>ACX.03.52</b></p> <p>Descrizione Description ANTIEFFRAZIONE Antibreakage Braccio Chiusura Closure Arm</p>		<p><b>ACX.03.61</b></p> <p>Descrizione Description ANTIEFFRAZIONE Antibreakage Chiusura Sist. sicurezza connessione Astina Bar Connection Safety System</p>	

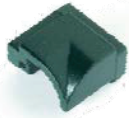













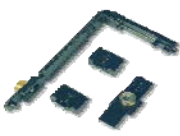

<p><b>ACX.03.62</b></p> <p>Descrizione <i>Description</i> <b>Incontro a pozzetto Puntale</b> <i>Drain Rest Plate Tooling for Tip</i></p> <p style="text-align: right;">Ø 6 mm.</p>		<p><b>ACX.03.71</b></p> <p>Descrizione <i>Description</i> <b>Catenaccio a Leva "Mini tex"</b> <i>"Mini tex" Lever Bolt</i></p> <p style="text-align: right;">Sirio</p>	
<p><b>ACX.03.63</b></p> <p>Descrizione <i>Description</i> <b>Incontro a pozzetto</b> <i>Drain Rest Plate</i></p> <p style="text-align: right;">per puntale Ø 6 mm.</p>		<p><b>ACX.03.72</b></p> <p>Descrizione <i>Description</i> <b>Movimentazione Bidirezionale</b> <i>Bidirectional Movement</i></p> <p style="text-align: right;">Interasse/Center Dist.=23/35 mm.</p>	
<p><b>ACX.03.64</b></p> <p>Descrizione <i>Description</i> <b>Corpo di manovra a leva</b> <i>Lever Manoeuvring Body</i></p> <p style="text-align: right;">"Mini tex."</p>		<p><b>ACX.03.73</b></p> <p>Descrizione <i>Description</i> <b>Martellina ridotta</b> <i>Reduced Martellina handle</i></p> <p style="text-align: right;">Sporg Quadrol Rosette Projection 70 mm.</p>	<p>"COMFORT MINI"</p> 
<p><b>ACX.03.65</b></p> <p>Descrizione <i>Description</i> <b>Catenaccio a leva Bidirezionale</b> <i>Bidirectional lever bolt</i></p> <p style="text-align: right;">"bi-hid" kit</p>		<p><b>ACX.03.74</b></p> <p>Descrizione <i>Description</i> <b>Martellina ridotta con cilindro</b> <i>Reduced Martellina handle w/Cylinder</i></p> <p style="text-align: right;">Sporg Quadrol Rosette Projection 70 mm.</p>	<p>"COMFORT MINI"</p> 
<p><b>ACX.03.66</b></p> <p>Descrizione <i>Description</i> <b>Perno di trascinamento</b> <i>Winding Pivot</i></p> <p style="text-align: right;">L=11 mm.</p>		<p><b>ARX.04.30</b></p> <p>Descrizione <i>Description</i> <b>Tappo a L battuta inferiore porte</b> <i>L-shaped Plug Bottom Rabbet</i></p>	
<p><b>ACX.03.67</b></p> <p>Descrizione <i>Description</i> <b>Perno di trascinamento</b> <i>Winding Pivot</i></p> <p style="text-align: right;">L=27 mm.</p>		<p><b>ARX.04.31</b></p> <p>Descrizione <i>Description</i> <b>Tappo a L battuta inferiore porte</b> <i>L-shaped Plug Bottom Rabbet</i></p>	
<p><b>ACX.03.68</b></p> <p>Descrizione <i>Description</i> <b>Doppia maniglia "Comfort mini"</b> <i>Double Handle "Comfort MINI"</i></p>		<p><b>ACX.04.54</b></p> <p>Descrizione <i>Description</i> <b>Ripporto Tondo/Dritto/Round/Straight Wing</b> <b>Tappo Ripporto Giunto Aperto</b> <i>Open Coupling Wing Plug</i></p>	
<p><b>ACX.03.69</b></p> <p>Descrizione <i>Description</i> <b>Doppia maniglia "ITALIA"</b> <i>Double Handle "ITALIA"</i></p>		<p><b>ACX.04.55</b></p> <p>Descrizione <i>Description</i> <b>Ripporto Tondo/Dritto/Round Straight Wing</b> <b>Tappo Ripporto Ferramenta Nastro</b> <i>Tape Hardware Wing Plug</i></p>	
<p><b>ACX.03.70</b></p> <p>Descrizione <i>Description</i> <b>Catenaccio a comando diretto</b> <i>Direct drive bolt</i></p> <p style="text-align: right;">Sirio</p>		<p><b>ACX.04.56</b></p> <p>Descrizione <i>Description</i> <b>Ripporto Tondo/Dritto/Round/Straight Wing</b> <b>Tappo Ripporto Doppia Battua</b> <i>Double Gasket Wing Plug</i></p>	

















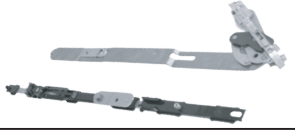

<p><b>ARX.04.60</b></p> <p>Descrizione <i>Description</i>  <b>Tappo per XX70.643</b>  <b>Porta Spazzolino ANTA</b>  <i>Plug for XX70.643 Sash Brush Holder</i></p>		<p><b>ACX.06.04</b></p> <p>Descrizione <i>Description</i>  <b>Registro Z/P</b>  <i>Z/P Adjusting screw</i></p>	
<p><b>ARX.04.69B</b></p> <p>Descrizione <i>Description</i>  <b>Tappo profilo scivolo BIANCO</b>  <i>WHITE Plug for slide profile</i></p>		<p><b>ARX.06.XX</b></p> <p>Descrizione <i>Description</i>  <b>Grano per registro</b>  <i>Adjusting Grub Screw</i></p>	<ul style="list-style-type: none"> <li>• ARX.06.08 L=15 mm.</li> <li>• ARX.06.09 L=20 mm.</li> <li>• ARX.06.10 L=30 mm.</li> <li>• ARX.06.11 L=45 mm.</li> </ul> 
<p><b>ARX.04.69G</b></p> <p>Descrizione <i>Description</i>  <b>Tappo profilo scivolo GRIGIO</b>  <i>GREY Plug for slide profile</i></p>		<p><b>ARX.06.13</b></p> <p>Descrizione <i>Description</i>  <b>Registro TWIN Autobloccante su Barrette di Poliammide</b>  <i>TWIN Adjusting screw Self-locking on Polyamide Bars</i></p>	
<p><b>ARX.04.69N</b></p> <p>Descrizione <i>Description</i>  <b>Tappo profilo scivolo NERO</b>  <i>BLACK Plug for slide profile</i></p>		<p><b>ACX.06.14/15</b></p> <p>Descrizione <i>Description</i>  <b>Registro TWIN Autobloccante su Barrette di Poliammide</b>  <i>TWIN Adjusting screw Self-locking on Polyamide Bars</i></p>	<p><b>ACX.06.14</b> foro/hole D=6mm</p> <p><b>ACX.06.15</b> foro/hole D=8mm</p> 
<p><b>ARX.04.70</b></p> <p>Descrizione <i>Description</i>  <b>Tappo Gocciolatorio Profilo XX70.2040</b>  <i>Dropper Plug for XX70.2040</i></p>		<p><b>ACX.06.16</b></p> <p>Descrizione <i>Description</i>  <b>Rondella di fissaggio per ARX06.14/15</b>  <i>TWIN Fixing Washer for ACX06.14/15</i></p>	
<p><b>ARX.05.01</b></p> <p>Descrizione <i>Description</i>  <b>Pluggetta drenaggio acqua</b>  <i>Water Drainage Plug</i></p>		<p><b>ACX.07.02</b></p> <p>Descrizione <i>Description</i>  <b>Angolo Universale Fermavetro</b>  <i>Universal Corner Glazing Bead</i></p>	
<p><b>ARX.06.01</b></p> <p>Descrizione <i>Description</i>  <b>Registro Universale</b>  <i>Universal Adjusting Spacer Screw</i></p>		<p><b>ARX.07.09</b></p> <p>Descrizione <i>Description</i>  <b>Supporto vetro Universale</b>  <i>Glass support kit</i>  <b>Spessore   Width = 2/3mm</b></p>	
<p><b>ARX.06.02</b></p> <p>Descrizione <i>Description</i>  <b>Piastrina Registro Universale</b>  <i>Universal Plate Adjusting Screw</i></p>		<p><b>ACX.08.01</b></p> <p>Descrizione <i>Description</i>  <b>ANTA RIBALTA WEEN</b>  <b>TILT&amp;TURN SASH</b></p>	
<p><b>ARX.06.03</b></p> <p>Descrizione <i>Description</i>  <b>Grano per registro</b>  <i>Adjusting Grub Screw</i></p>		<p><b>c/anti falsa manovra sulla Cremonese</b>  <i>w/ wrong counter-actuation on the Cremonese bolt</i></p> <p><b>KIT BASE   BASE KIT</b>  <b>Portata/Plugacity 160 Kg.</b></p>	



<p><b>ACX.08.01L</b></p> <p>Descrizione <i>Description</i> <b>ANTA RIBALTA WEEN</b> <i>TILT&amp;TURN SASH</i></p> <p><b>Logica</b></p> <p><i>c/anti falsa manovra sulla Cremonese</i> <i>w/ wrong counter-actuation on the Cremonese bolt</i></p> <p><b>KIT BASE   BASE KIT</b> Portata/Plugacity 160 Kg.</p>		<p><b>ACX.08.19</b></p> <p>Descrizione <i>Description</i> <b>Microventilazione regolabile</b> <i>Adjustable micro-ventilation</i></p>	
<p><b>ACX.08.05</b></p> <p>Descrizione <i>Description</i> <b>A.R. Braccio Supplementare</b> <i>A.R. Supplementary Arm</i></p>		<p><b>ACX.08.22</b></p> <p>Descrizione <i>Description</i> <b>Anta Ribalta Braccio Corto</b> <i>Tilt&amp;Turn short arm</i></p> <p>L=395 mm. → 450 mm.</p>	
<p><b>ACX.08.05L</b></p> <p>Descrizione <i>Description</i> <b>A.R. Braccio Supplementare</b> <i>A.R. Supplementary Arm</i></p> <p><b>Logica</b></p>		<p><b>ACX.08.22L</b></p> <p>Descrizione <i>Description</i> <b>Anta Ribalta Braccio Corto</b> <i>Tilt&amp;Turn short arm</i></p> <p>L=395 mm. → 450 mm.</p>	
<p><b>ACX.08.06</b></p> <p>Descrizione <i>Description</i> <b>Chiusura Supplementare Verticale e Universale</b> <i>Supplementary Universal Vertical Closure</i></p>		<p><b>ACX.08.23</b></p> <p>Descrizione <i>Description</i> <b>Anta Ribalta Braccio Medio</b> <i>Tilt&amp;Turn medium arm</i></p> <p>L=451 mm. → 650 mm.</p>	
<p><b>ARX.08.09</b></p> <p>Descrizione <i>Description</i> <b>A.R. Cerniera a Pettine 2.0</b> <i>A.R. Comb Hinge 2.0</i></p>		<p><b>ACX.08.23L</b></p> <p>Descrizione <i>Description</i> <b>Anta Ribalta Braccio Medio</b> <i>Drop down door medium arm</i></p> <p>L=451 mm. → 650 mm.</p>	
<p><b>ACX.08.13</b></p> <p>Descrizione <i>Description</i> <b>Incontro asta singolo</b> <i>Single bar Rest Plate</i></p>		<p><b>ACX.08.24</b></p> <p>Descrizione <i>Description</i> <b>Anta Ribalta Braccio Lungo</b> <i>Tilt&amp;Turn long arm</i></p> <p>L=650 mm. → 1700 mm.</p>	
<p><b>ARX.08.16</b></p> <p>Descrizione <i>Description</i> <b>Perno chiusura supplementare</b> <i>Pin additional lock</i></p>		<p><b>ACX.08.24L</b></p> <p>Descrizione <i>Description</i> <b>Anta Ribalta Braccio Lungo</b> <i>Tilt&amp;Turn long arm</i></p> <p>L=650 mm. → 1700 mm.</p>	
<p><b>ACX.08.18</b></p> <p>Descrizione <i>Description</i> <b>Chiusura supplementare inferiore orizzontale</b> <i>Horizontal bottom additional closure</i></p>		<p><b>ACX.08.26</b></p> <p>Descrizione <i>Description</i> <b>Cerniere vasistas a scomparsa</b> <i>Wasistas concealed hinges</i></p>	<p><b>Ween hide 180</b></p> 
		<p><b>ACX.08.27</b></p> <p>Descrizione <i>Description</i> <b>Braccio AR a scomparsa</b> <i>Retractable short arm AR</i></p>	





<b>ACX.08.28</b>	<b>Ween hide 180</b> Braccio AR a scomparsa Retractable short arm AR
Descrizione <i>Description</i> Corto SX SHORT Left	
<b>ACX.08.29</b>	
Descrizione <i>Description</i> Corto DX SHORT Right <b>Logica</b>	
<b>ACX.08.30</b>	
Descrizione <i>Description</i> Corto SX SHORT Left <b>Logica</b>	
<b>ACX.08.31</b>	
Descrizione <i>Description</i> Medio DX Medium Right	
<b>ACX.08.32</b>	
Descrizione <i>Description</i> Medio SX Medium Left	
<b>ACX.08.33</b>	
Descrizione <i>Description</i> Medio DX Medium Right <b>Logica</b>	
<b>ACX.08.34</b>	
Descrizione <i>Description</i> Medio SX Medium Left <b>Logica</b>	
<b>ACX.08.35</b>	<b>Ween hide 180</b>
Descrizione <i>Description</i> Supporto Anta Sash Support  Max load 170 Kg.	
<b>ACX.08.36</b>	<b>Ween hide 180</b>
Descrizione <i>Description</i>  DX   Right	
<b>ACX.08.37</b>	
Descrizione <i>Description</i>  SX   Left	

<b>ACX.08.38</b>	
Descrizione <i>Description</i>  DX   Right	
<b>ACX.08.39</b>	
Descrizione <i>Description</i>  SX   Left	
<b>ACX.08.40</b>	
Descrizione <i>Description</i> Rinvio d'angolo, terminali e riscontri in zama Corner return, terminals and handles in zamak.	
<b>ACX.08.41</b>	
<b>Logica</b>	
<b>ACX.08.42</b>	
Descrizione <i>Description</i> c/scatto microventilazione w/Microventilation Trigger	
<b>ACX.08.43</b>	
Descrizione <i>Description</i> Anta Ribalta Automatica Automatic Tilt&Turn Sash  Max load 160 Kg.	
<b>ACX.08.44</b>	
Descrizione <i>Description</i> Catenaccio a leva ad appoggio Lever Bolt  Sporg. Quadro   Rosette Projection 24 mm.	
<b>ACX.08.48</b>	
Descrizione <i>Description</i> Kit cerniere ribalta anta affiancata "ween" Hinge kit with Tilt&Turn addit. sash" Portata/Max Load 160 Kg.	
<b>ACX.08.49</b>	
Descrizione <i>Description</i> Chiusura supplementare laterale con riscontro regolabile Add closing w/adjustable counterplate	



<b>ACX.20.01</b>		<b>WI-CLOUD RC</b>
Descrizione	Description	
<b>Attuatore a catena radiocomandato</b>	<b>Remote-Controlled Chain Actuator</b>	

<b>ACX.20.02</b>		<b>WI-CONTROL</b>
Descrizione	Description	
<b>Radiocomando</b>	<b>Remote-Control</b>	

<b>ACX.20.03</b>		<b>WI-CLOUD</b>
Descrizione	Description	
<b>Attuatore a catena radiocomandato</b>	<b>Remote-Controlled Chain Actuator</b>	

<b>ACX.20.04</b>		<b>WI-CLOUD RC-LOCK</b>
Descrizione	Description	
<b>Attuatore a catena c/serratura elettromeccanica</b>	<b>Chain Actuator w/Electromechanical Lock</b>	

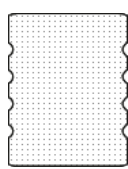















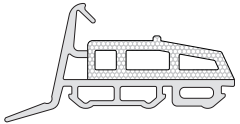
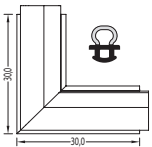

Descrizione	Description	
<b>LS</b>	<b>LISTELLO ISOLANTE</b> <b>INSULATING STRIP</b>	

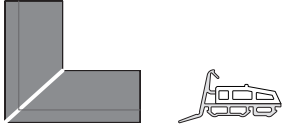
- LS 09 5x28 mm.
- LS 23 25x30 mm.
- LS 40 13x30 mm.
- LS 41 22x25 mm.
- LS 42 25x37 mm.
- LS 43 25x50 mm.
- LS 44 30x58 mm.
- LS 45 40x13 mm.

<b>ACX.04.63</b>		
Descrizione	Description	
<b>Clip per profili XX70.503-504</b>	<b>Profile clip XX70.503-504</b>	

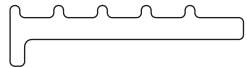

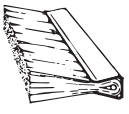
## GUARNIZIONI | GASKETS

<p><b>ACX.10.03</b></p> <p>Descrizione <i>Description</i> Guarnizione di battuta a scatto <i>Snap-On Rabbet window gasket</i></p>		<p><b>ARX.10.XX</b></p> <p>Descrizione <i>Description</i></p> <p><b>Guarnizione Vetro INT</b> <i>Glass Window Gasket INT</i></p>	 <p><b>ARX.10.12</b> Spessore   Width 3 - 4 mm.</p>  <p><b>ARX.10.13</b> Spessore   Width 5 - 6 mm.</p>  <p><b>ARX.10.14</b> Spessore   Width 7 - 8 mm.</p>  <p><b>ARX.10.15</b> Spessore   Width 9 - 10 mm.</p>
<p><b>ACX.10.04</b></p> <p>Descrizione <i>Description</i> Guarnizione di battuta ad infilo <i>Rabbet window gasket to insert</i></p>		<p><b>ASX.10.35</b></p> <p>Descrizione <i>Description</i> Guarnizione rigida per porte <i>Rigid window gasket for doors</i></p>	
<p><b>ACX.10.04.1</b></p> <p>Descrizione <i>Description</i> Guarnizione di battuta ad infilo 3.5mm <i>Rabbet window gasket to insert</i></p>		<p><b>ACX.10.58.1</b></p> <p>Descrizione <i>Description</i> Guarnizione centrale di Precamera <i>Pre-chamber Central window gasket</i></p>	
<p><b>ACX.10.04.2</b></p> <p>Descrizione <i>Description</i> Angolo per Guarnizione di battuta ad infilo ACX.10.04.01 <i>Corner for rabbet window gasket to insert ACX.10.04.01</i></p>		<p><b>ARX.10.05.1</b></p> <p>Descrizione <i>Description</i> Guarnizione vetro esterna coestrusa per isolamento termico-acustico <i>Coextruded external glass gasket for thermal-acoustic insulation</i></p>	
<p><b>ARX.10.07</b></p> <p>Descrizione <i>Description</i> Guarnizione di battuta acustica <i>EXT glass acoustic window gasket</i></p>		<p><b>ACX.10.59</b></p> <p>Descrizione <i>Description</i> Angolo per Guarnizione centrale di Precamera ARX.10.58.1 <i>Corner for Pre-chamber Central window gasket</i></p>	
<p><b>ARX.10.08</b></p> <p>Descrizione <i>Description</i> Guarnizione di battuta <i>Rabbet window gasket</i></p>	<p>FERRAMENTA A NASTRO TAPE HARDWARE</p> 	<p><b>ACX.10.71</b></p> <p>Descrizione <i>Description</i> Guarnizioni fermavetro di sicurezza (a pezzi) <i>Item for safety glazing bead (in pieces)</i></p>	
<p><b>ARX.10.10</b></p> <p>Descrizione <i>Description</i> Spazzola a pavimento con supporto <i>Window door seal brush w/holder</i></p>		<p><b>ACX.10.81</b></p> <p>Descrizione <i>Description</i> Guarnizione sotto vetro <i>Gasket under glass</i></p>	
<p><b>ARX.10.27</b></p> <p>Descrizione <i>Description</i> Rotella infila guarnizioni <i>Window gasket threader</i></p>		<p><b>ARX.10.83</b></p> <p>Descrizione <i>Description</i> Spazzola a pavimento H 15 mm <i>Window door seal brush H. 15 mm.</i></p>	
<p><b>ARX.10.97</b></p> <p>Descrizione <i>Description</i> Guarnizione profilo doga <i>Gasket for stave profile</i></p>			



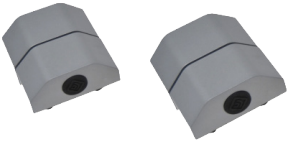

## ACCESSORI BILICO Vertical PIVOT

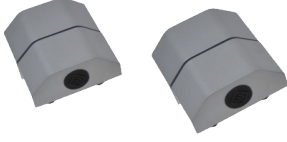
<b>ARX.03.75</b>	
<p>Descrizione <i>Description</i>  <b>Coppia cerniere a frizione con blocco</b>  <i>Couple of friction hinges for pivoty window without lock</i></p>	

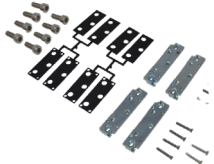
<b>ARX.03.76</b>	
<p>Descrizione <i>Description</i>  <b>Coppia cerniere a frizione senza blocco</b>  <i>Couple of friction hinges for pivoty window without lock</i></p>	

<b>ACX.03.77</b>	
<p>Descrizione <i>Description</i>  <b>Guarnizione di battuta a scatto</b>  <i>Snap-On Rabbet window gasket</i></p>	

<b>ACX.03.78</b>	
<p>Descrizione <i>Description</i>  <b>Kit chiusura perimetrale base bilico CX</b>  <i>Multi-point locking kit for pivot window CX groove</i></p>	

<b>ACX.03.79</b>	
<p>Descrizione <i>Description</i>  <b>Kit chiusura perimetrale supplementare bilico CX</b>  <i>Multi-point locking kit for pivot window CX groove</i></p>	

<b>ARX.03.80</b>	
<p>Descrizione <i>Description</i>  <b>Riscontro per chiusure supplementari</b>  <i>Adjustable striker for additional closing CX</i></p>	

<b>ACX.03.81</b>	
<p>Descrizione <i>Description</i>  <b>Chiusura supplementare perno eccentrico</b>  <i>Supplementary locking eccentric pin</i></p>	

<b>ARX.03.04</b>	
<p>Descrizione <i>Description</i>  <b>Martellina</b>  <i>Martellina HANDLE</i>          Sporg. Quadro/Rosette Projection=26 mm.</p>	

<b>ACX.08.42</b>	
<p>Descrizione <i>Description</i>          c/scatto microventilazione  <i>w/Microventilation Trigger</i></p>	

<b>ACX.08.60</b>	
<p>Descrizione <i>Description</i>  <b>Martellina</b>  <i>Martellina HANDLE</i>          Sporg. Quadro/Rosette Projection=24 mm.</p>	

## Bilico VERTICALE Vertical PIVOT

<b>ACX.03.08</b>	
<p>Descrizione <i>Description</i>  <b>Cremonese "COMFORT"</b>  <i>Cremonese handle</i>          interasse/ Center Distance 84.5/104</p>	

<b>ACX.03.59</b>	
<p>Descrizione <i>Description</i>  <b>Cremonese "ITALIA"</b>  <i>Cremonese handle</i>          interasse/ Center Distance 84.5/104</p>	

<b>ACX.03.10</b>	
<p>Descrizione <i>Description</i>  <b>Bloccetto collegamento unidirezionale</b>  <i>Connecting block one-way</i></p>	

<b>ACX.03.82</b>	
<p>Descrizione <i>Description</i>  <b>Bloccetto collegamento</b>  <i>Connecting block</i></p>	

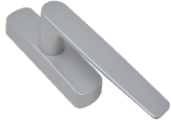
<b>ACX.08.83</b>	
<p>Descrizione <i>Description</i>  <b>Cremonese "KARMA"</b>  <i>Cremonese handle</i></p>	

## Bilico ORIZZONTALE Horizontal PIVOT

<b>ARX.03.94</b>	
<p>Descrizione <i>Description</i>  <b>Bloccetto collegamento</b>  <i>Connecting block</i></p>	

<b>ARX.03.45</b>	
<p>Descrizione <i>Description</i>  <b>Perno trascinamento</b>  <i>Winding Pivot</i>          L= 22 mm.</p>	

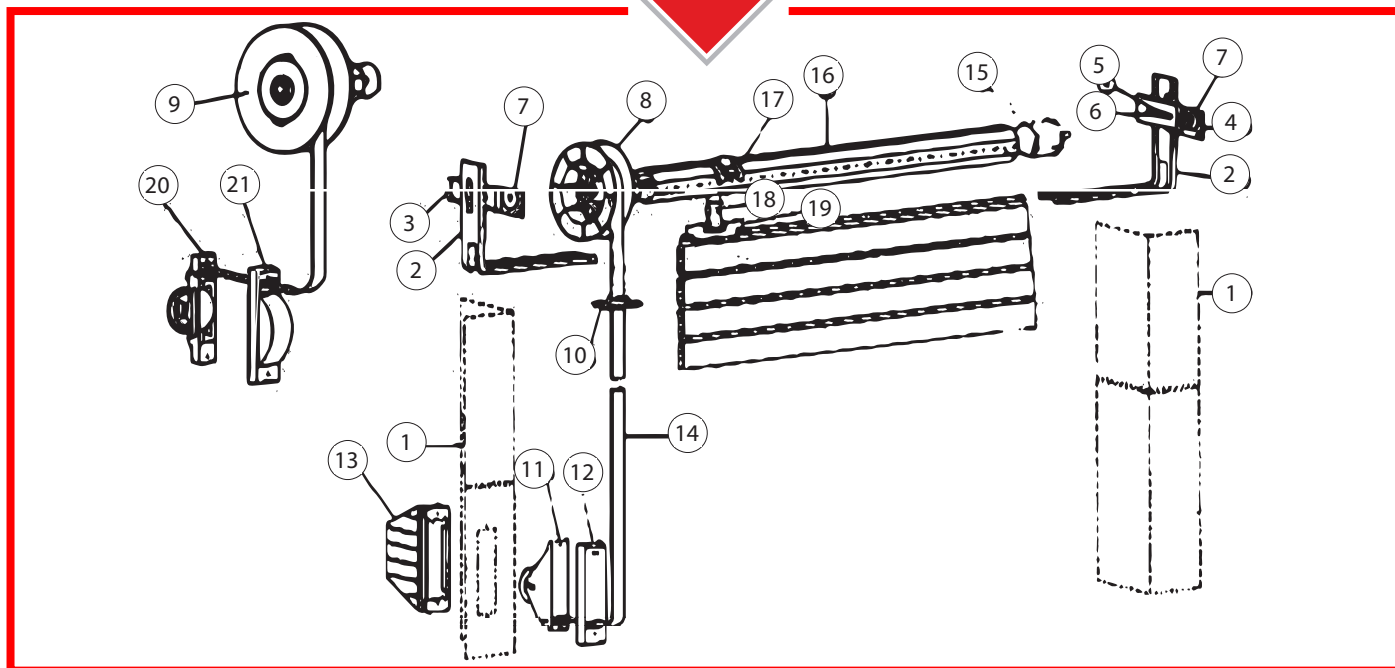

**MONOBLOCCO - Soluzione Puleggia | Monobloc - Solution with pulley**

Art./Item	Descrizione   Description	Dim (mm.)	Rif.   Ref.	Scelta Choice	Rif.   Ref.
ARX.11.01	Supporto a squadra   Square support	A = 46	<b>2</b>		<b>2</b>
ARX.11.02	Mensola per Supporto(SX)   Support Shelf (Left)		<b>1</b>		<b>3</b>
ARX.11.03	Mensola per Supporto(DX)   Support Shelf (Right)		<b>1</b>		<b>4</b>
ARX.11.04	Vite 6x20 c/dado   Screw W/Nut		<b>2</b>		<b>5-6</b>
ARX.11.05	Boccola in Nylon   Nylon Bushing		<b>2</b>		<b>7</b>
ARX.11.06	Puleggia in Plastica a Minimo Ingombro   Small Sized Plastic Pulley	Ø 220	<b>1</b>	Tipo   Type	<b>8</b>
ARX.11.07	Guida Cinghia Trasversale in Nylon   Nylon cross strap guide		<b>1</b>	Tipo   Type	<b>10</b>
ARX.11.08	Avvolgitore   Rewinder		<b>1</b>		<b>11</b>
ARX.11.09	Placca   Plaque		<b>1</b>	Tipo   Type	<b>12</b>
ARX.11.10	Cassetta   Cassette		<b>1</b>	Tipo   Type	<b>13</b>
ARX.11.11	Cintolino   Tape		<b>Mt.</b>	Tipo   Type	<b>14</b>
ARX.11.12	Calotta in Plastica   Plastic Cap		<b>1</b>		<b>15</b>
ARX.11.13	Rullo Ottagonale   Octagonal Roller		<b>Mt.</b>	Tipo   Type	<b>16</b>
ARX.11.14	Gancio Attacco Cintino/Rullo   Hook for attaching the tape to the roller		<b>2</b>		<b>17</b>
ARX.11.15	Grappa Fermacintino   Tape Locking Clip		<b>2</b>		<b>18</b>
ARX.11.16	Gancio per Avvolgibile in Plastica c/Asola   Plastic Roller Hook w/Slot		<b>2</b>		<b>19</b>

**MONOBLOCCO - Soluzione Puleggia | Monobloc - Solution with pulley**

ARX.11.18	Riduttore portata 40 kg.   Square support A= mm 46.	R=1;2.8	<b>1</b>		<b>9</b>
	Puleggia	Ø 220	<b>1</b>		
ARX.11.19	Avvolgitore   Rewinder		<b>1</b>		<b>20</b>
ARX.11.20	Placca   Plaque		<b>1</b>	Tipo   Type	<b>21</b>

**Vari | Miscellaneous**

ARX.11.21	Invito Tapparella [Nylon su Profilo Alluminio]   Shutter Guide [Nylon on Aluminium Profile]				
ARX.11.22	Coppia Tappi Lateral Cassonetto in Alluminio   Pair of side caps for aluminium shutter box				
ARX.11.23	Supporto a squadra   Square support A= mm 46.				





**Nodi**  
*Main Sections*

**Gruppo D**

Sezioni principali  
e Accessori  
Sc. 1:1

*Main Sections and  
Accessories  
Scale 1:1*



SCHEMA DIMENSIONALE  
DIMENSIONAL DIAGRAM

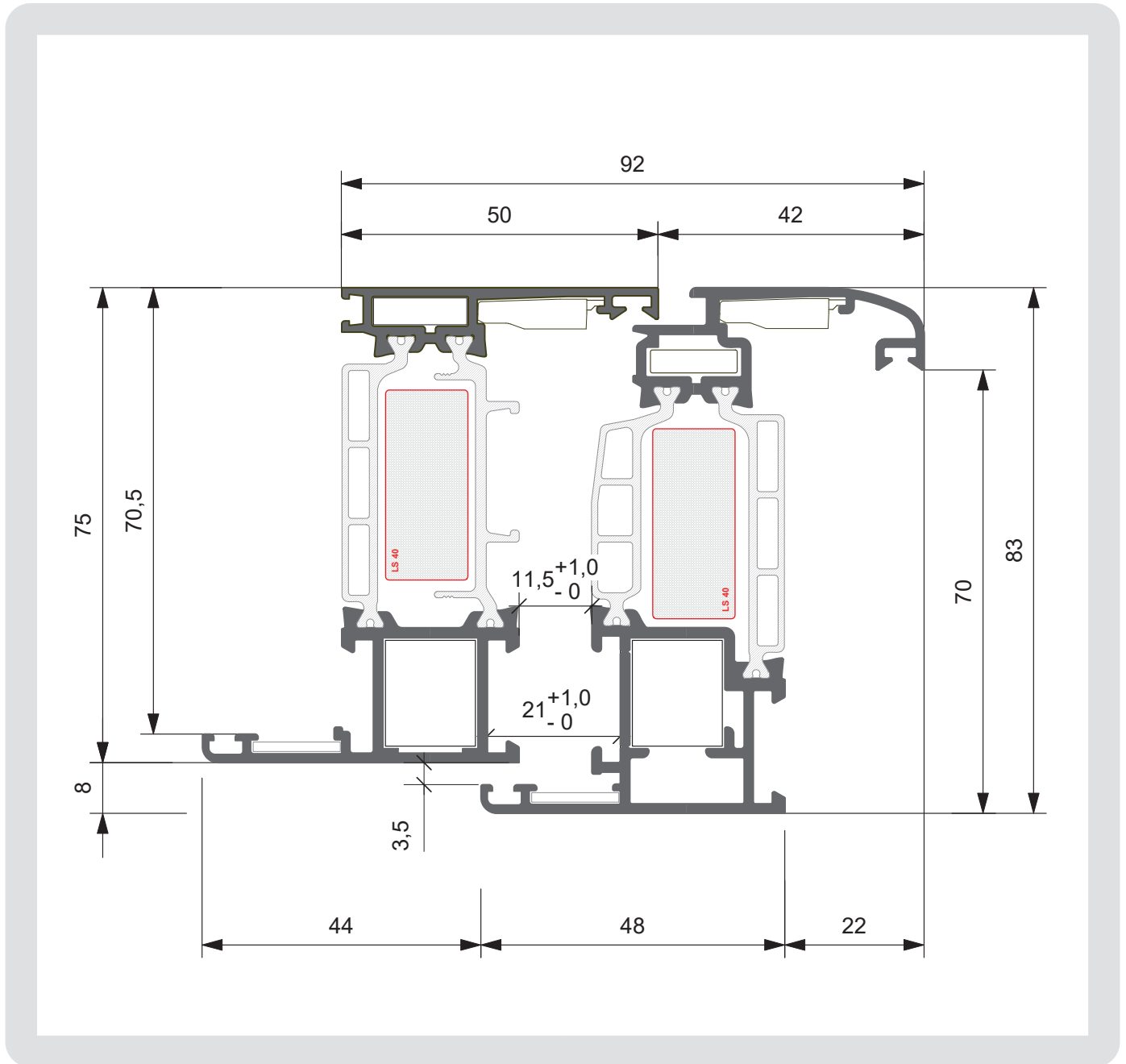



**FINESTRA A DUE ANTE**  
*DOUBLE SASH WINDOW*

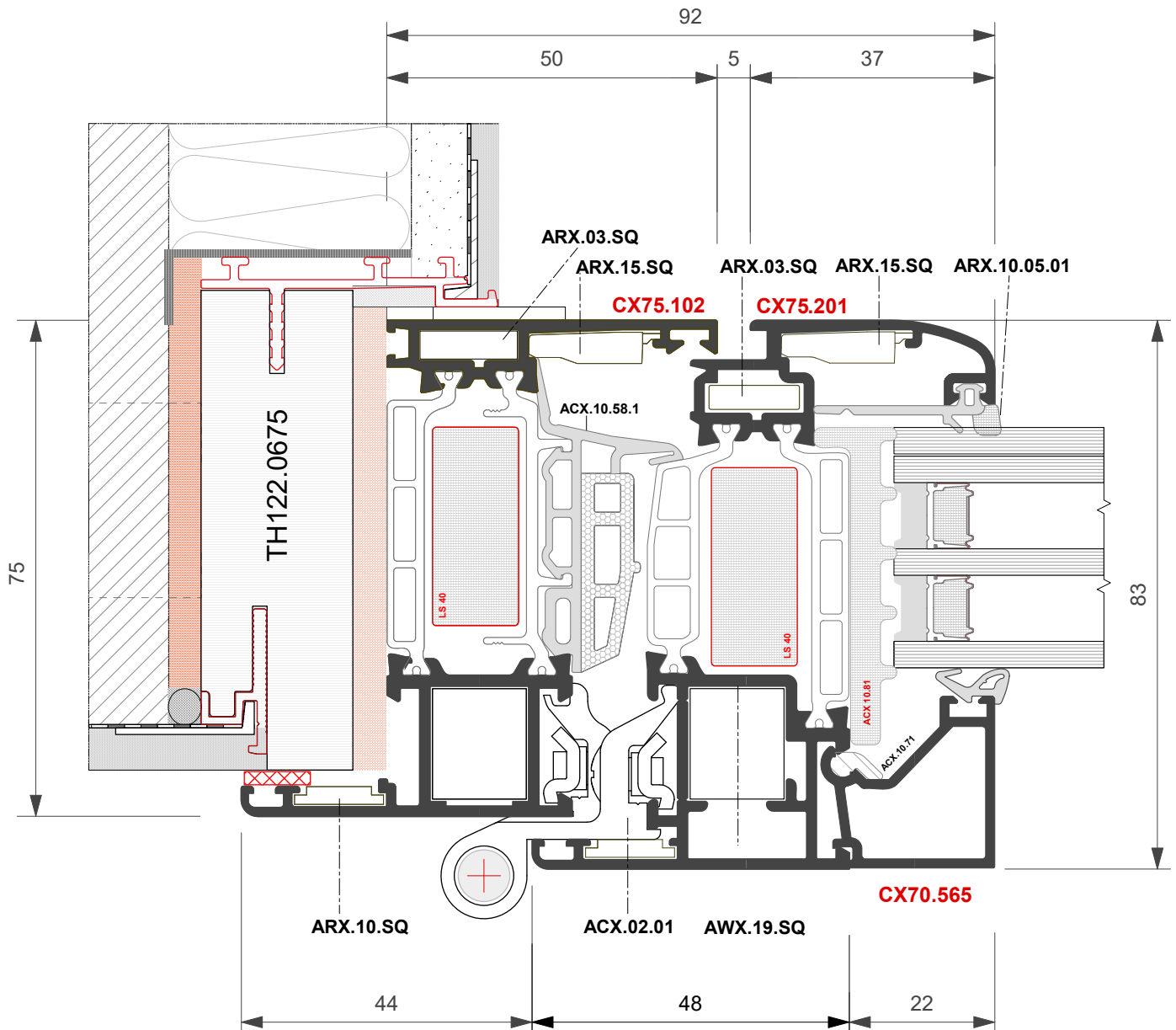
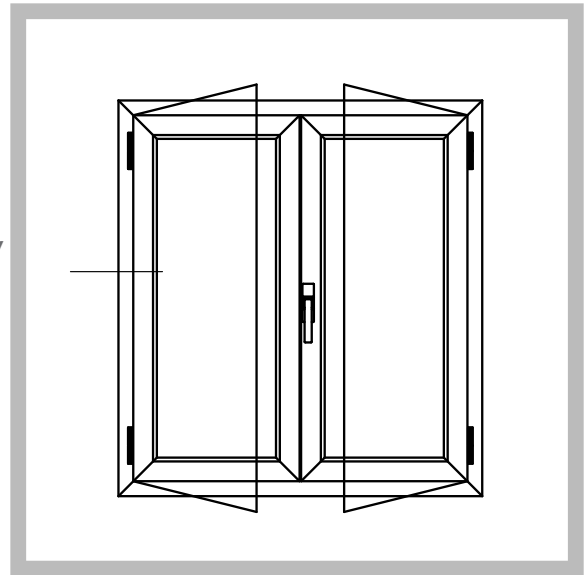



**FINESTRA A DUE ANTE**  
*DOUBLE SASH WINDOW*

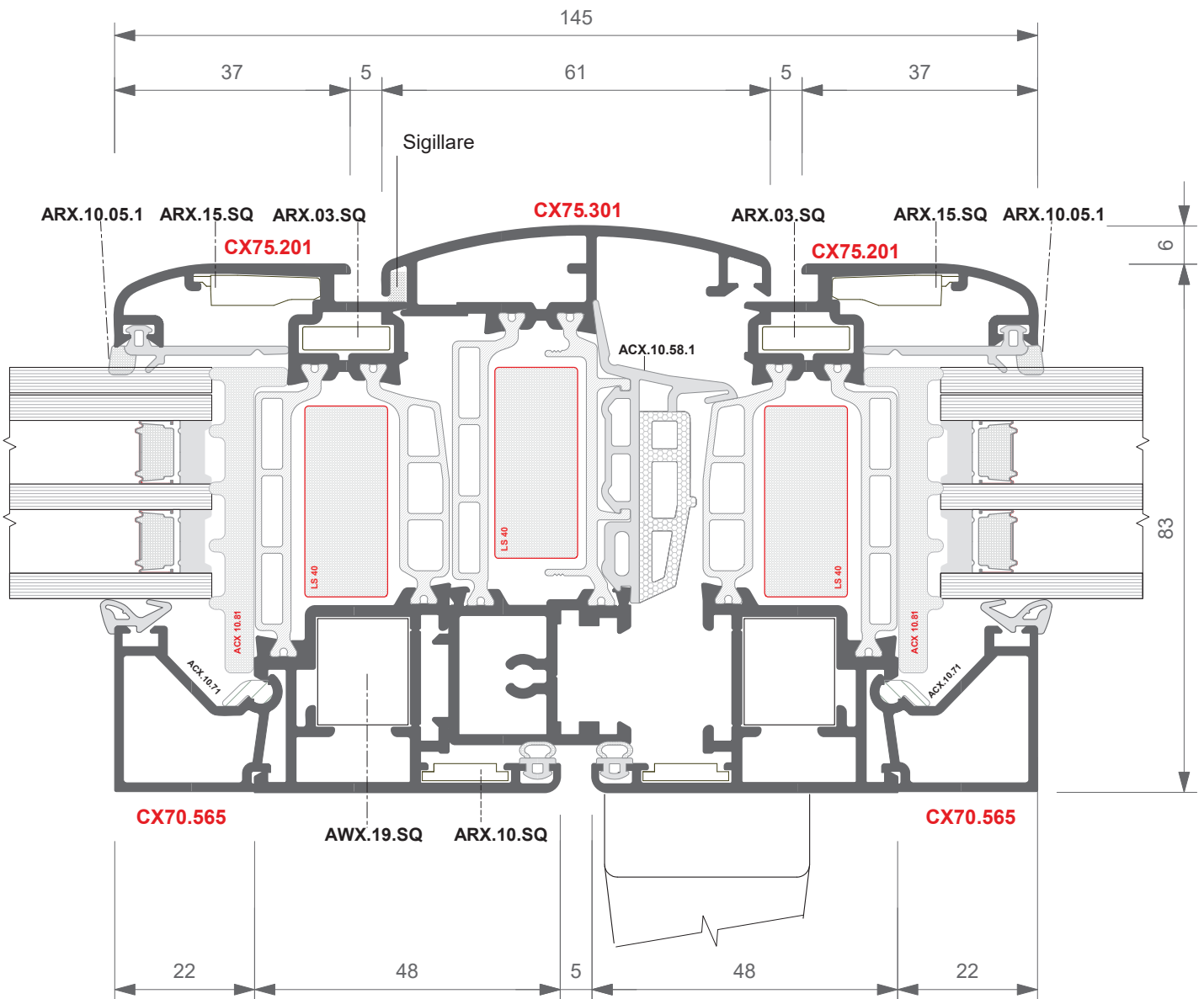
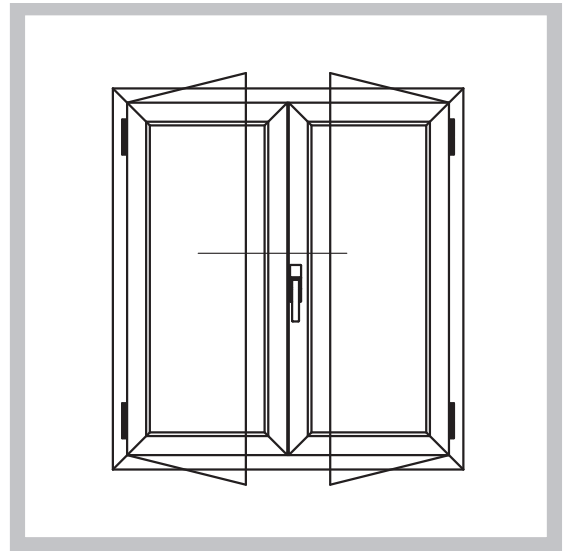



**FINESTRA A DUE ANTE**  
DOUBLE SASH WINDOW

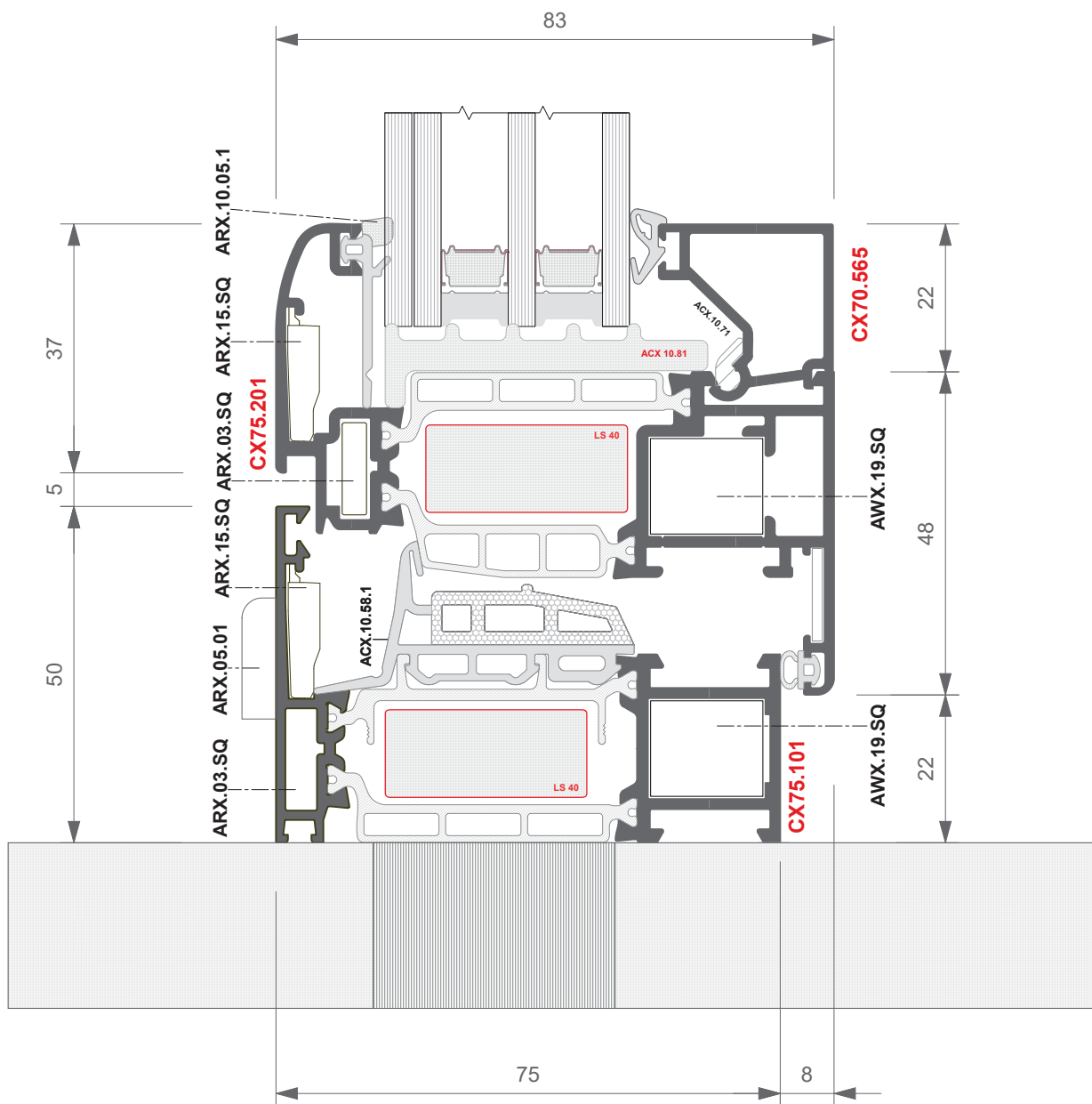
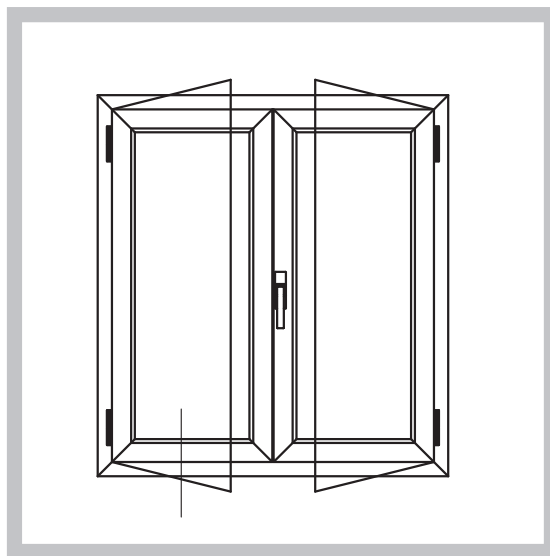





**PORTA BALCONE A DUE ANTE**  
con soglia bassa  
*DOUBLE SASH BALCONY DOOR*  
W/LOW THRESHOLD

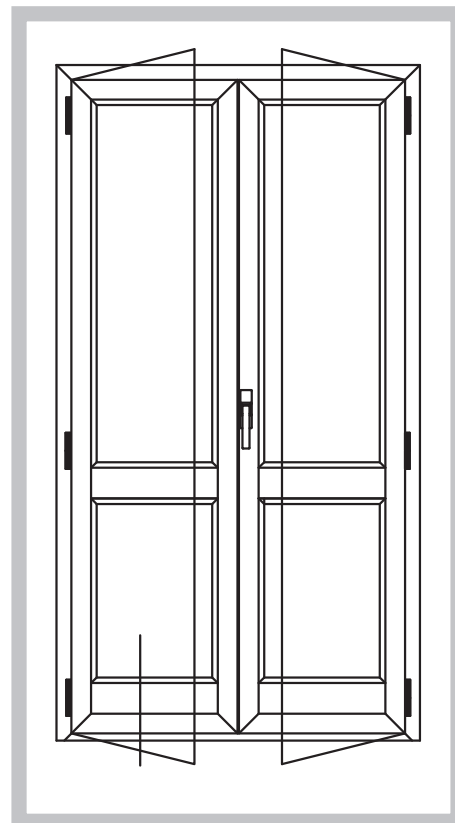
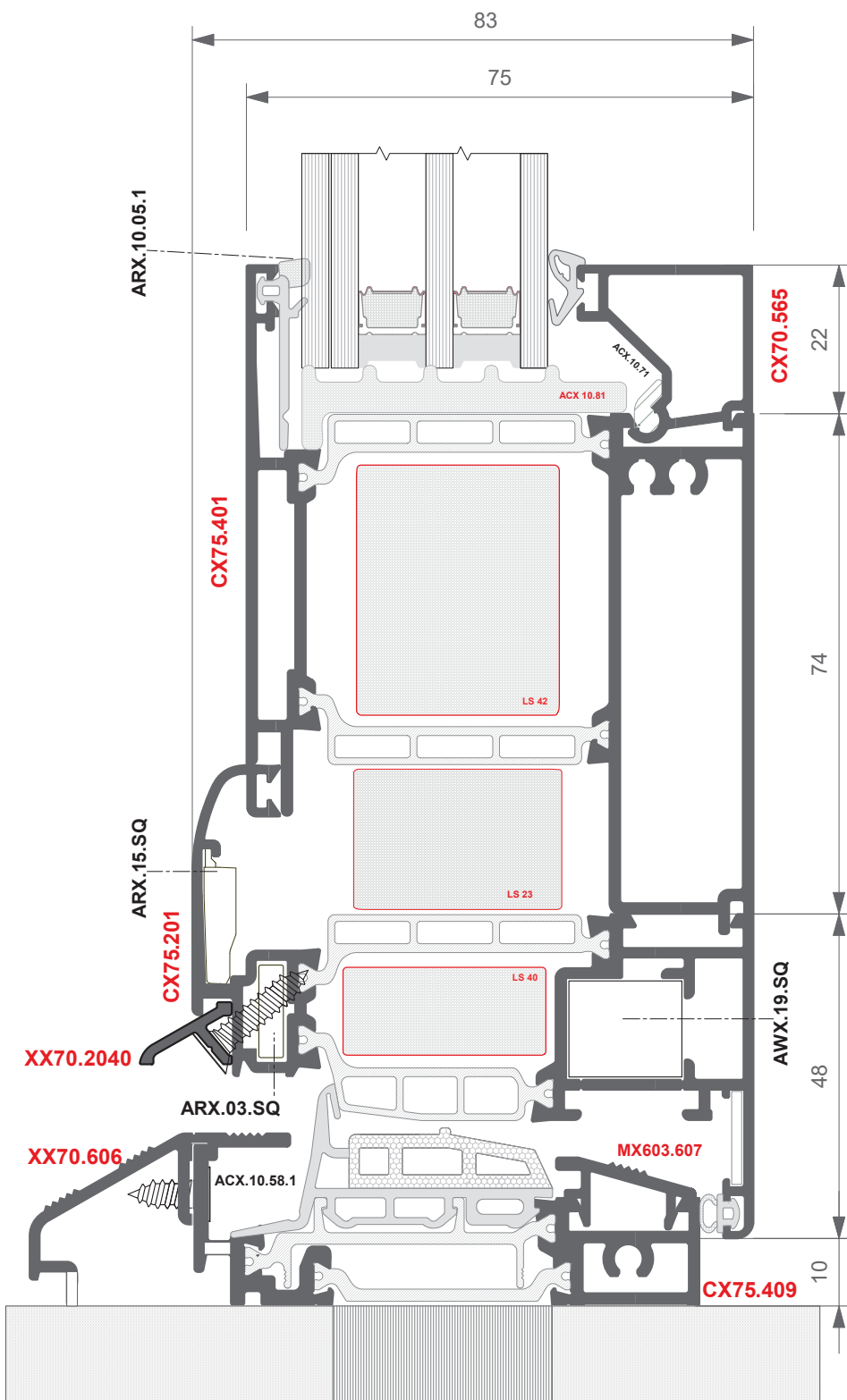



**PORTA BALCONE A DUE ANTE**  
*DOUBLE SASH BALCONY DOOR*

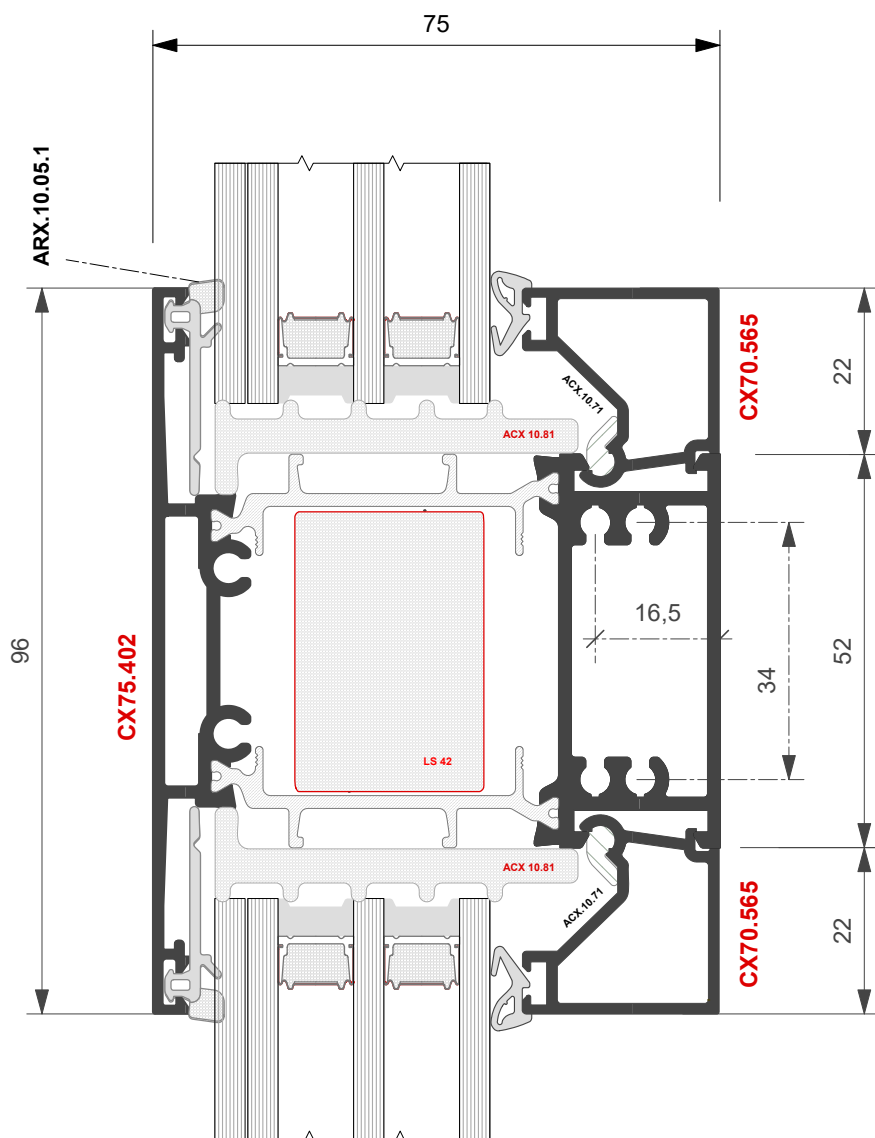
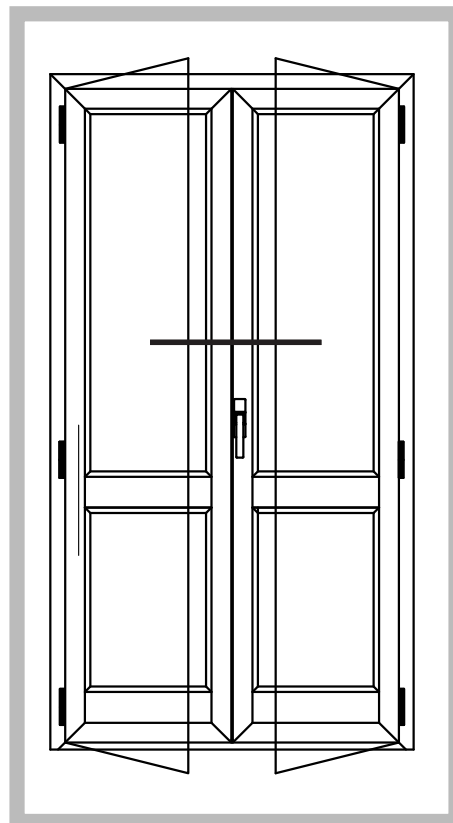



**FINESTRA A DUE ANTE**  
*DOUBLE SASH WINDOW*

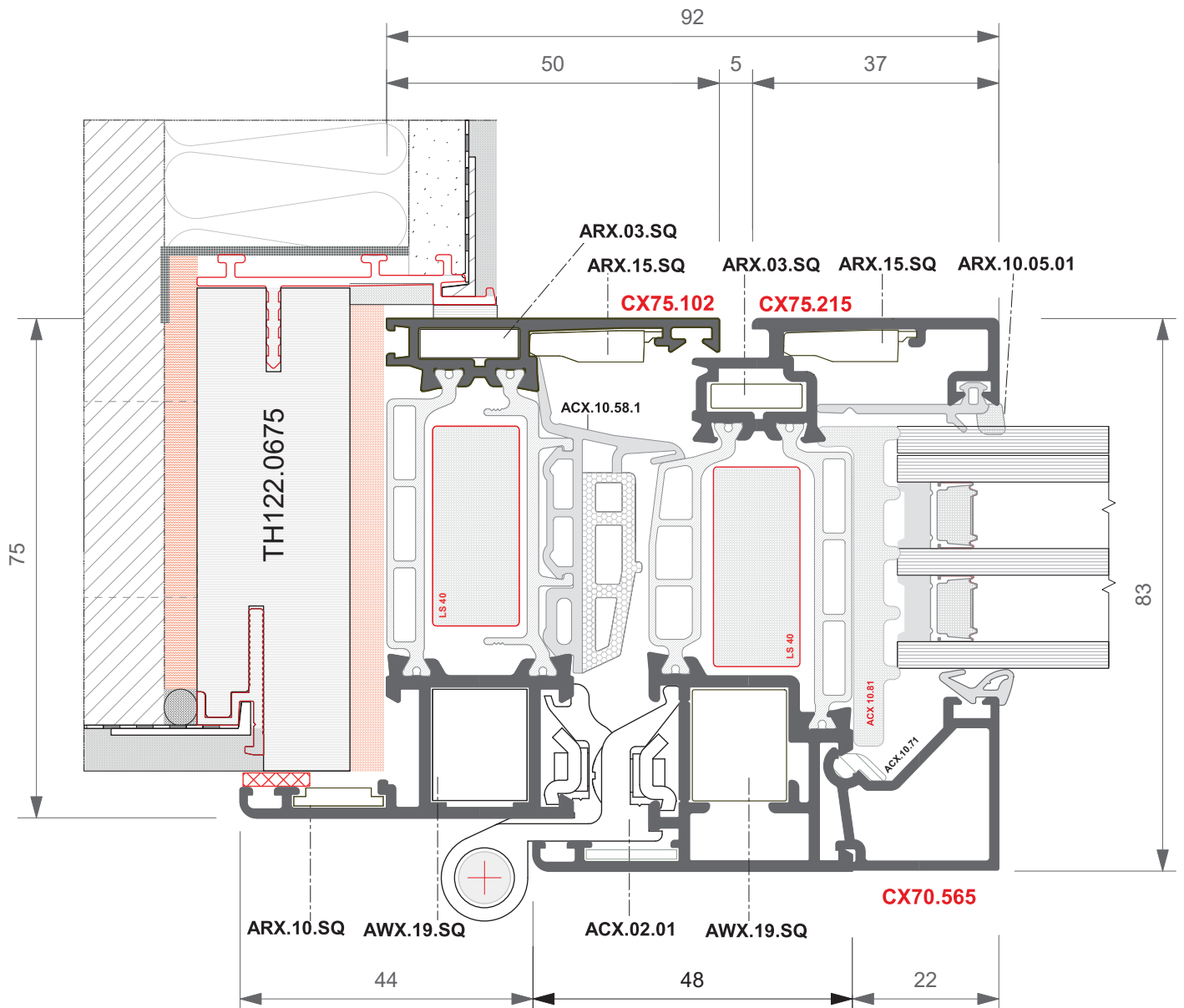
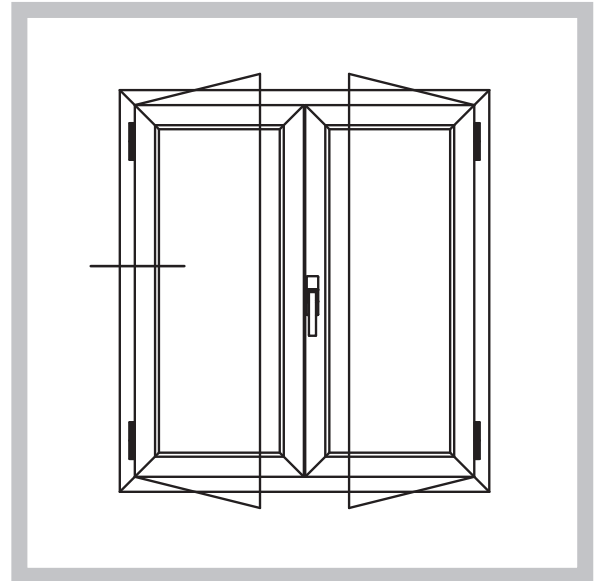



**FINESTRA A DUE ANTE**  
DOUBLE SASH WINDOW

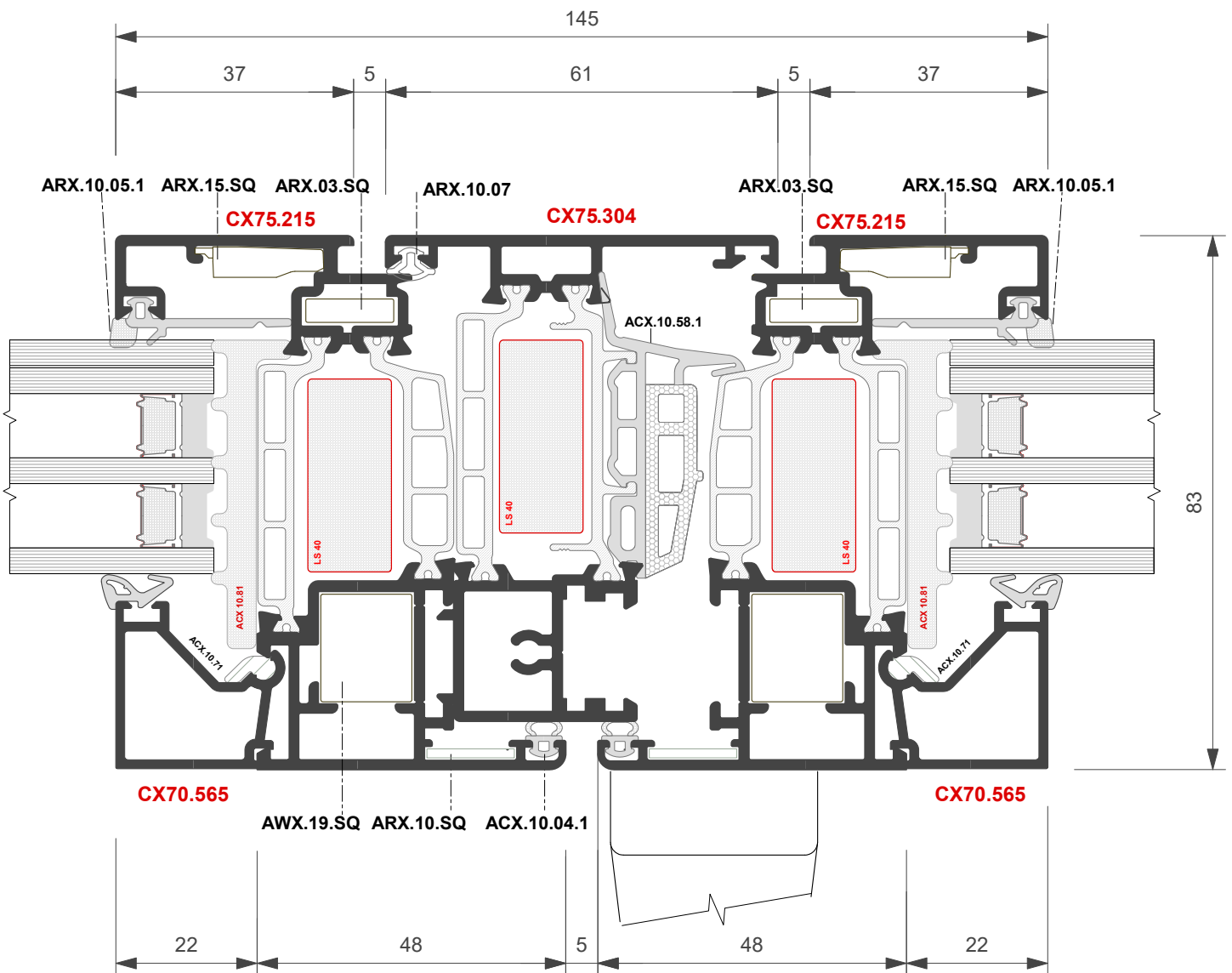
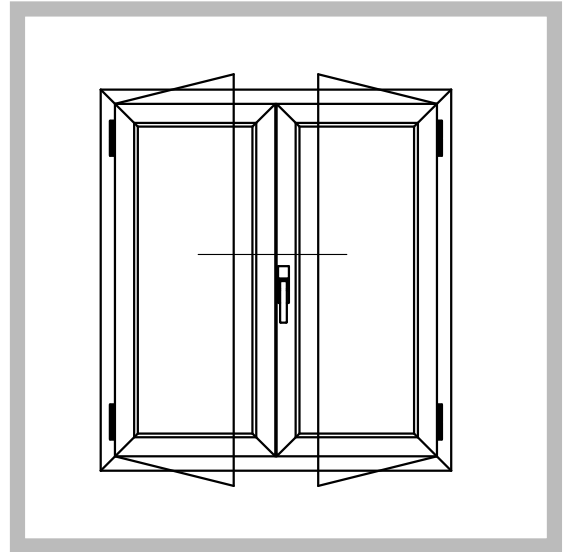

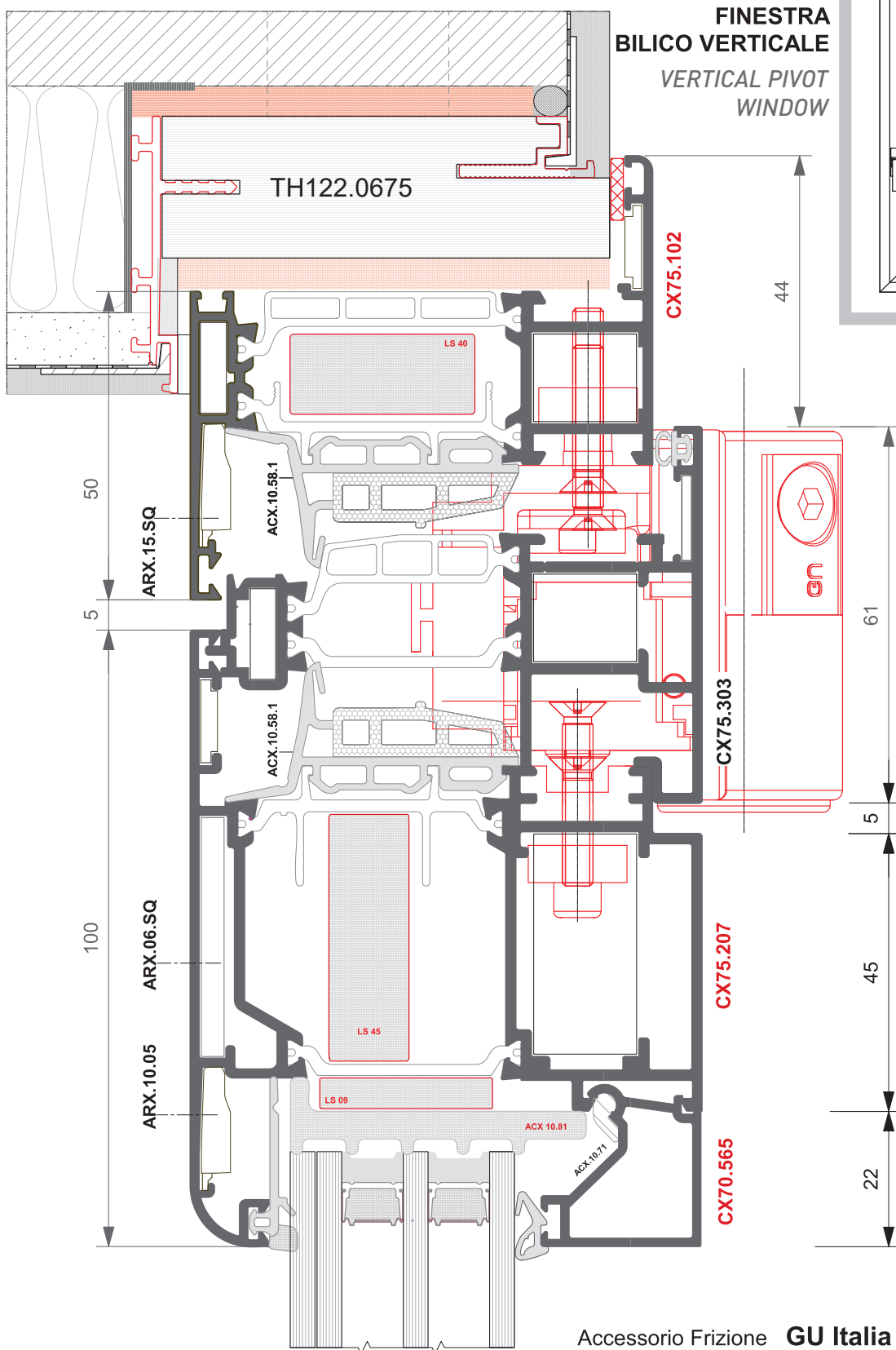

**FINESTRA**  
**BILICO VERTICALE**  
VERTICAL PIVOT  
WINDOW

Accessorio Frizione **GU Italia U - 88**  
**Articolo 6 - 27337-08 - P**  
per accessori di movimentazione riferirsi  
alla tavola di assieme



**ELEMENTO FISSO**  
FIXED GLASS

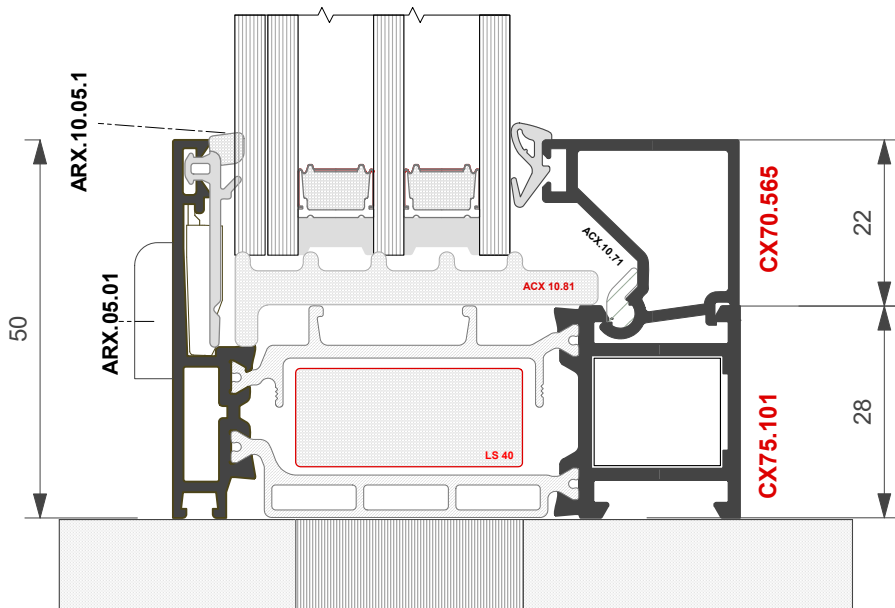
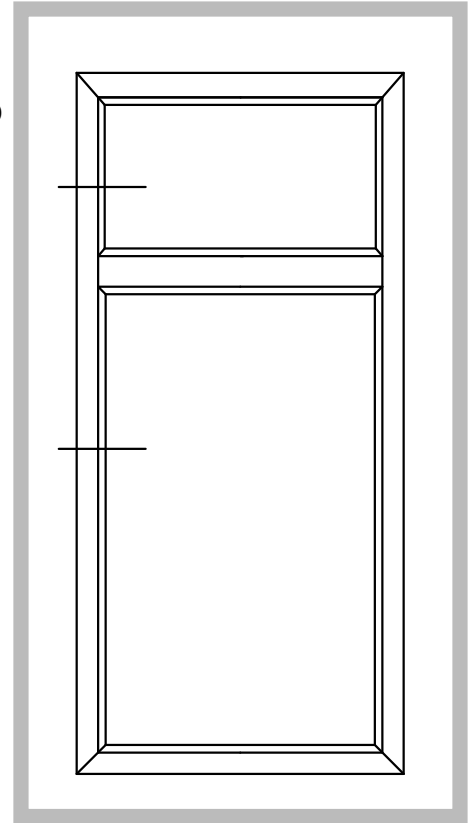
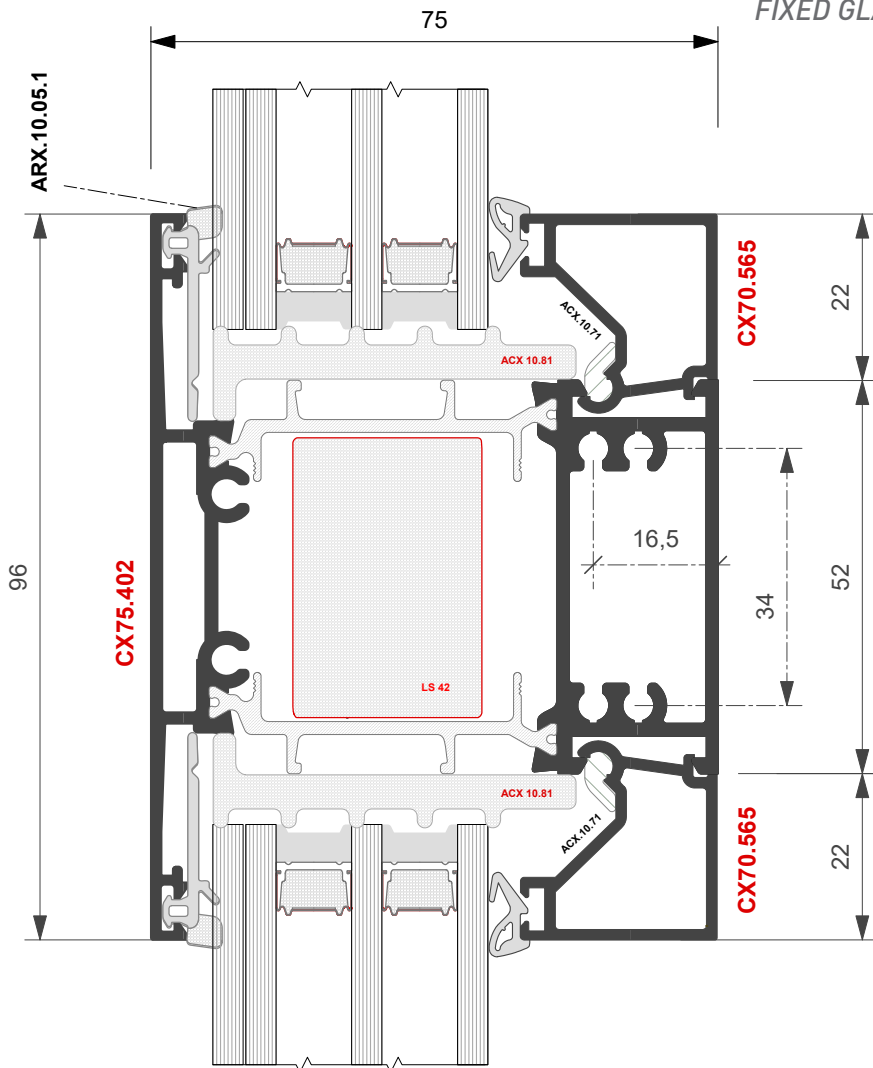



**Ferramenta a nastro**  
TAPE HARDWARE

**FINESTRA A DUE ANTE**  
DOUBLE SASH WINDOW

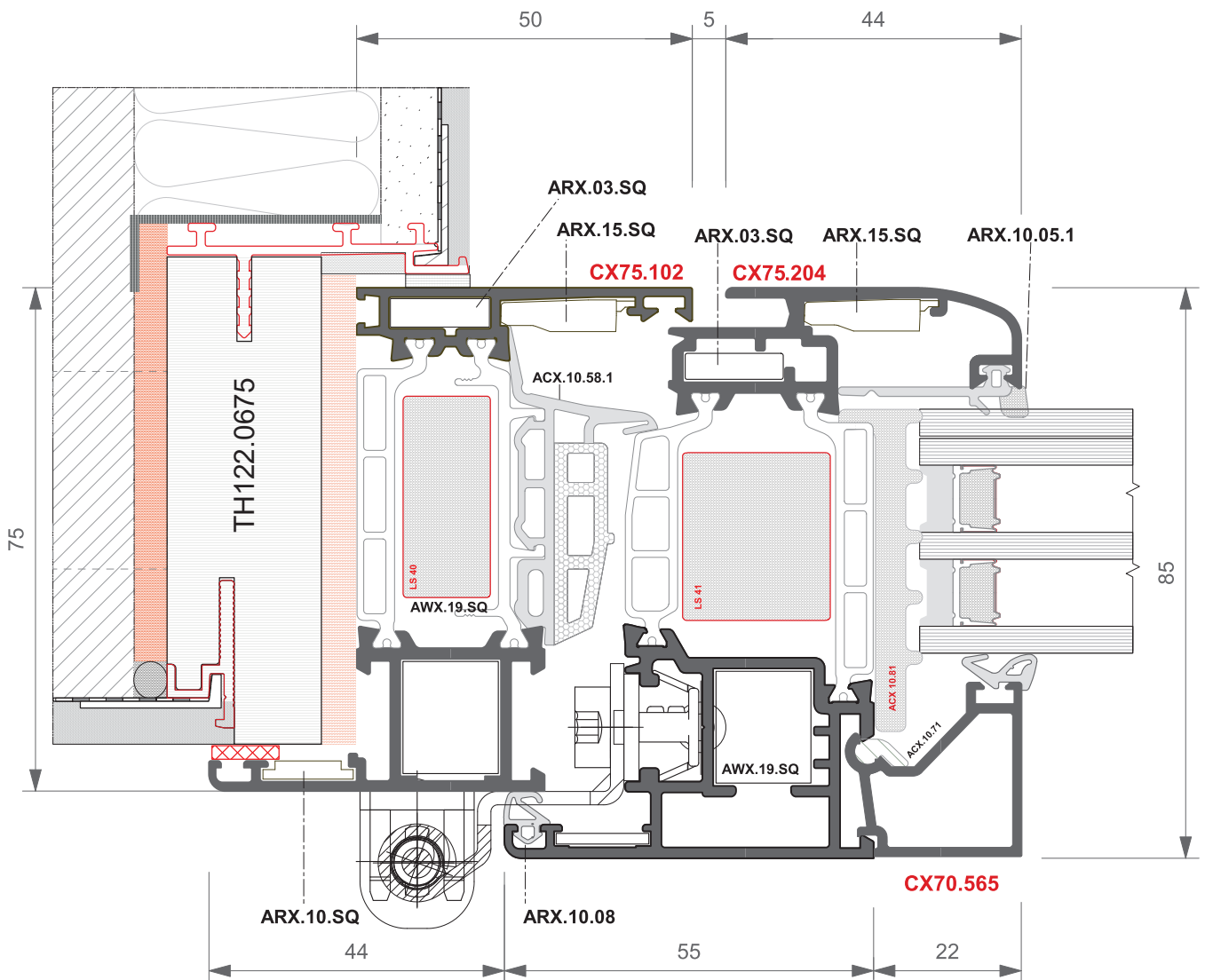
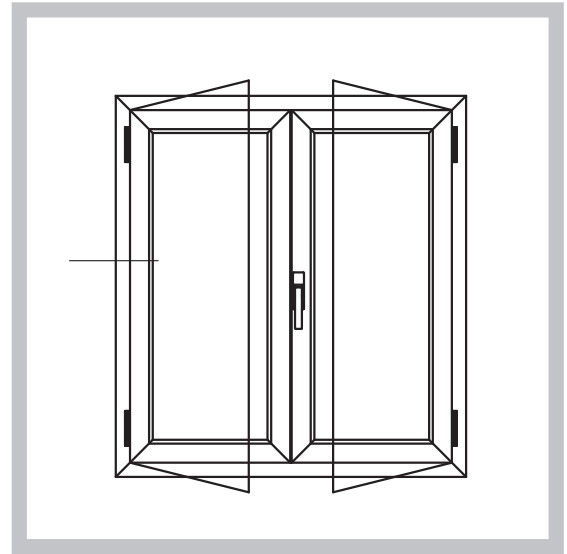



**Ferramenta a nastro**  
TAPE HARDWARE

**FINESTRA A DUE ANTE**  
DOUBLE SASH WINDOW

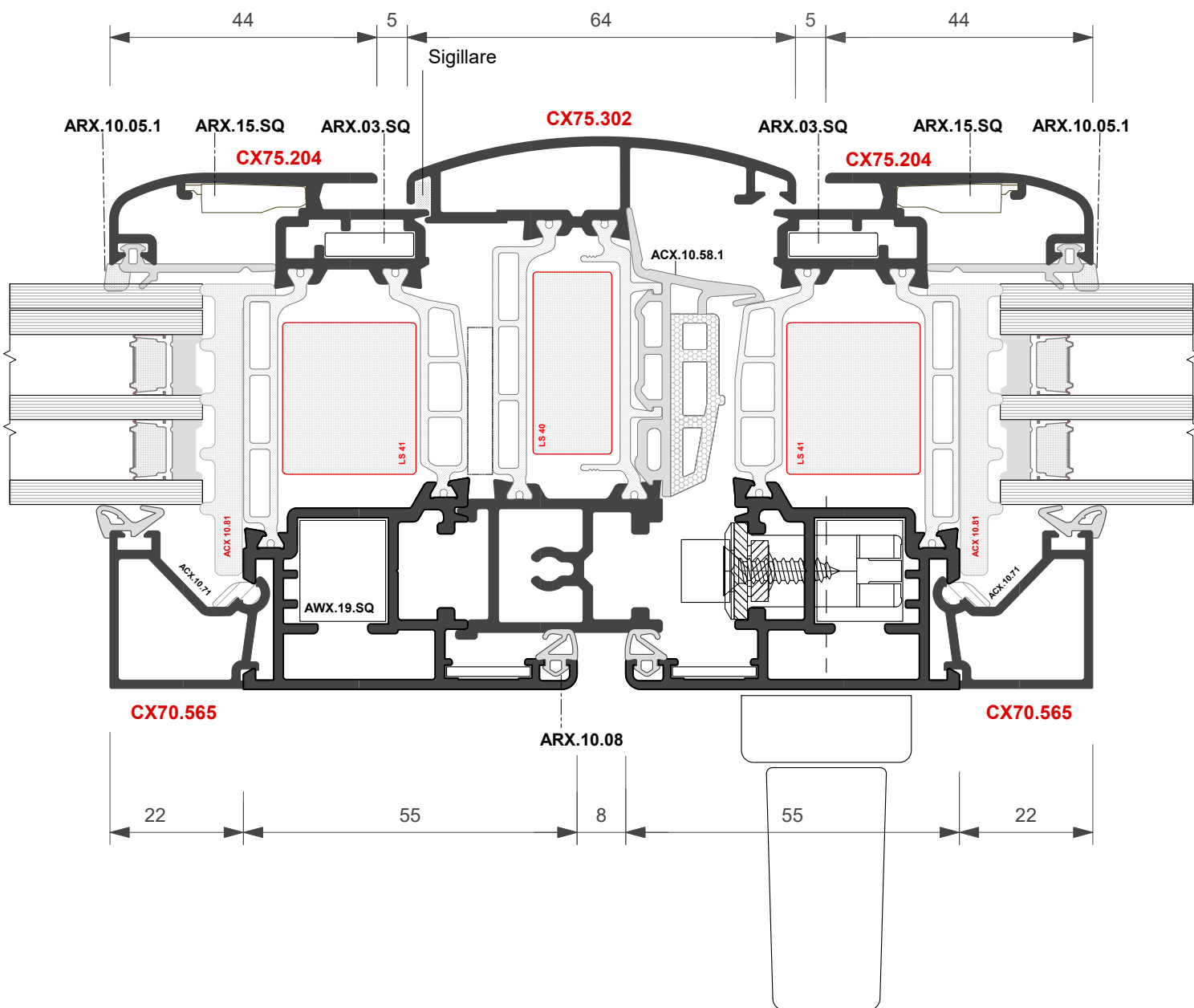
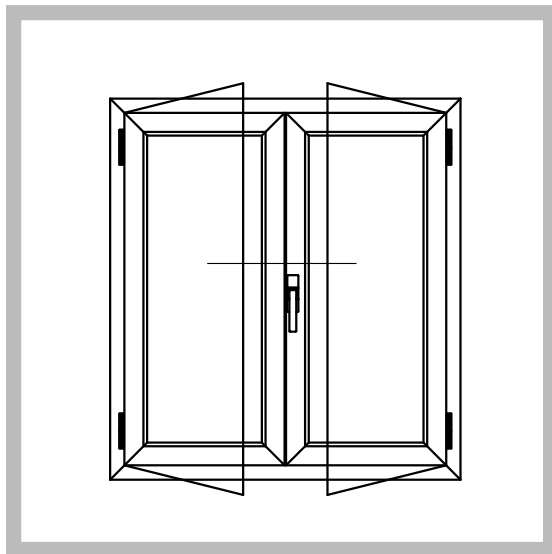



**FINESTRA A DUE ANTE**  
**Scorrevole in parallelo**  
*DOUBLE SASH WINDOW*  
*Parallel Sliding*

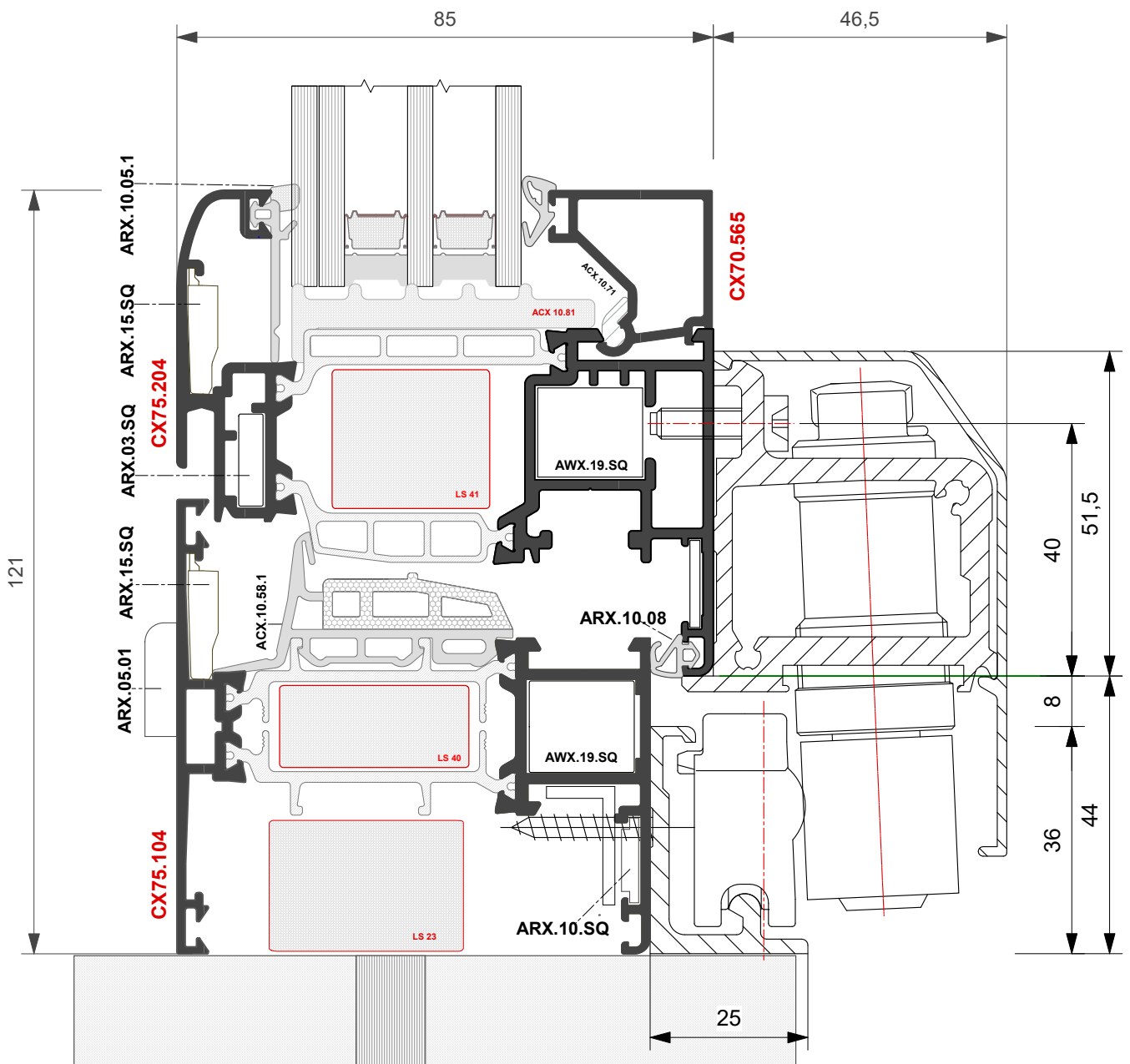
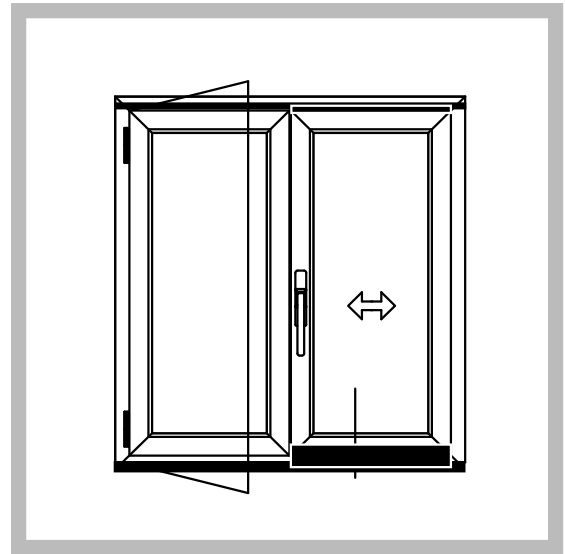



**Ferramenta a nastro**  
TAPE HARDWARE

**FINESTRA A DUE ANTE**  
Scorrevole in parallelo  
*DOUBLE SASH WINDOW*  
*Parallel Sliding*

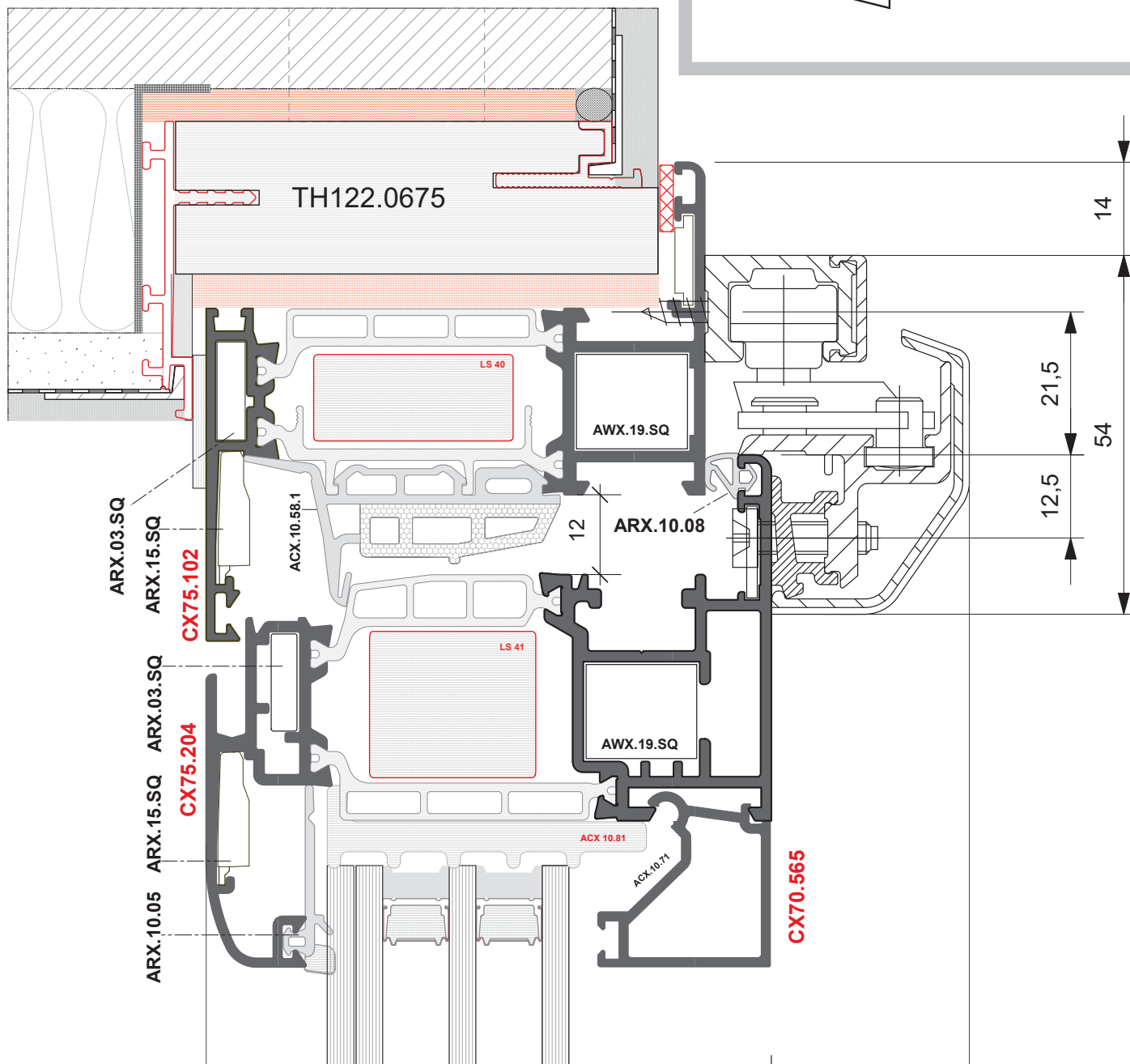
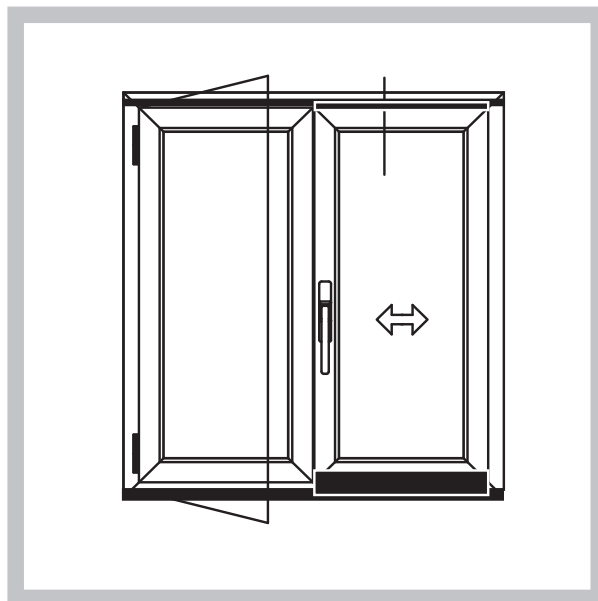



**Ferramenta a nastro**

TAPE HARDWARE

**PORTA BALCONE A DUE ANTE**  
DOUBLE SASH BALCONY DOOR  
85

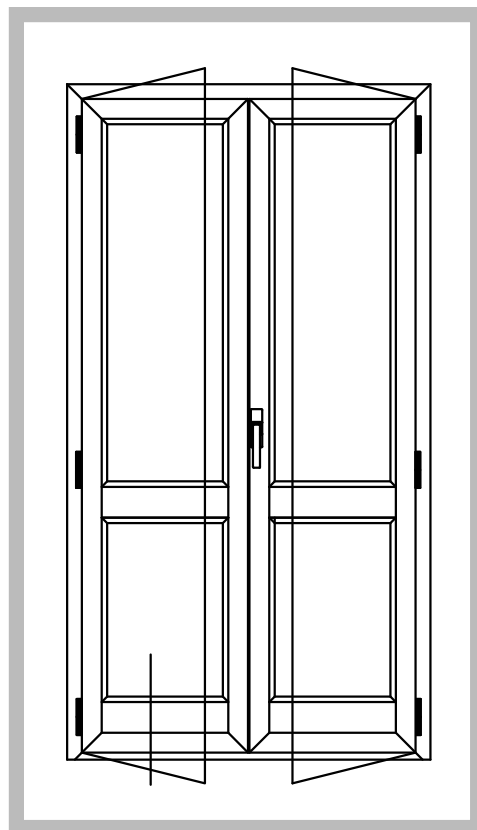
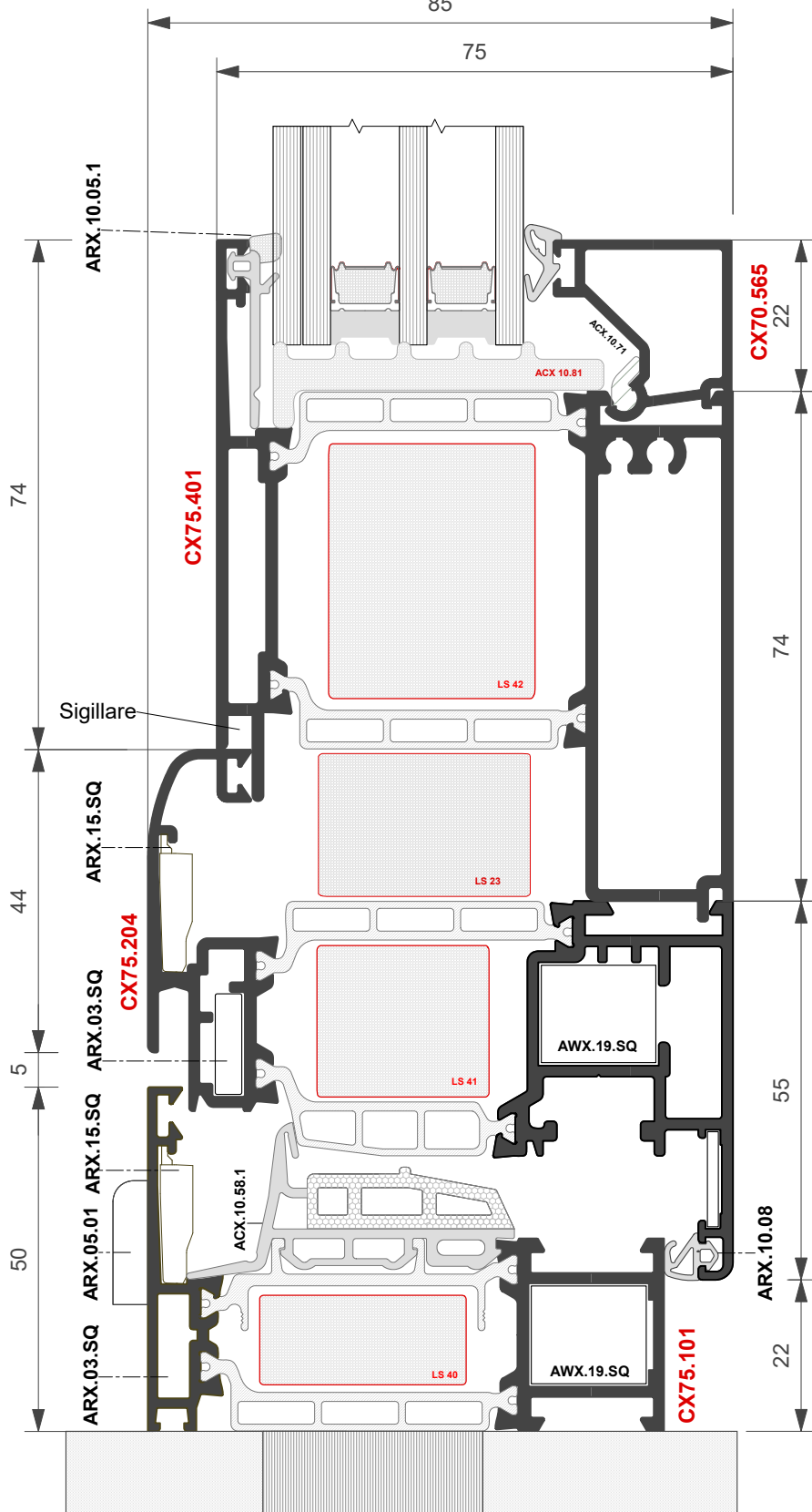



## Ferramenta a nastro

TAPE HARDWARE

**PORTA BALCONE A DUE ANTE**  
DOUBLE SASH BALCONY DOOR

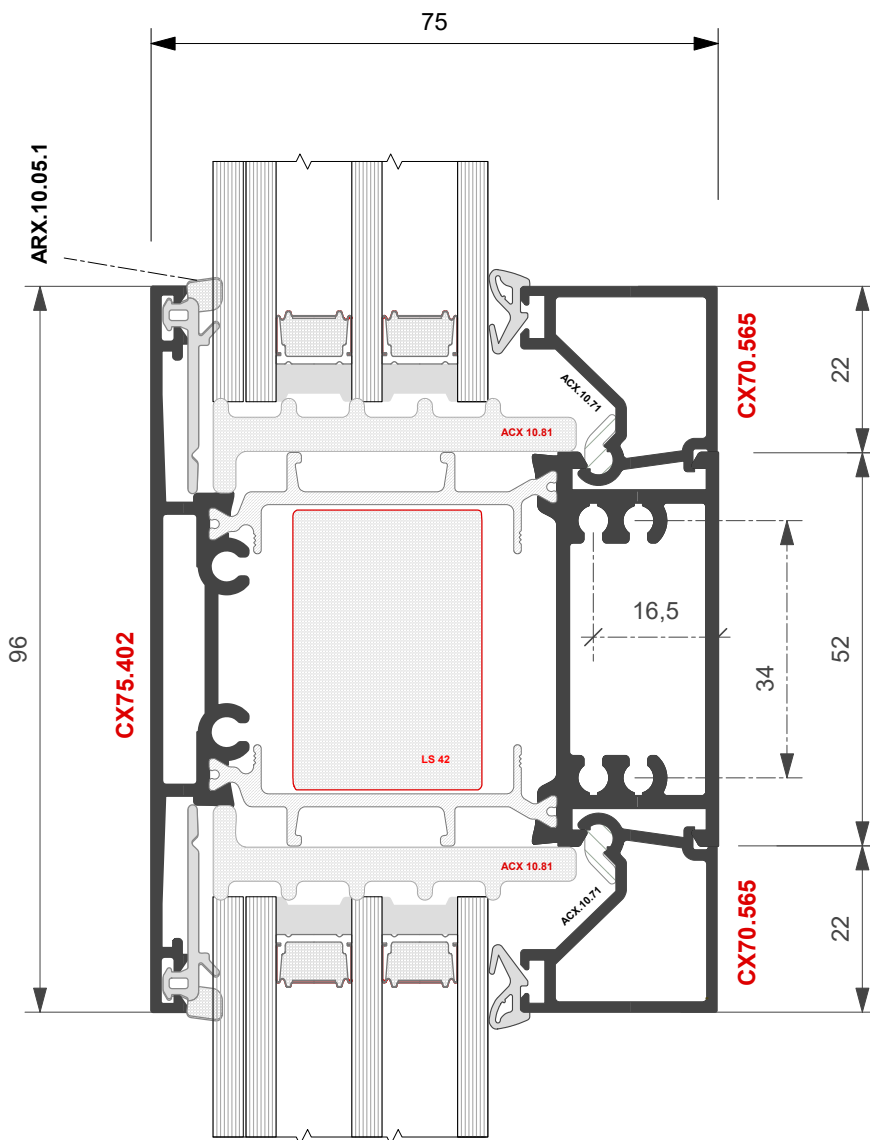
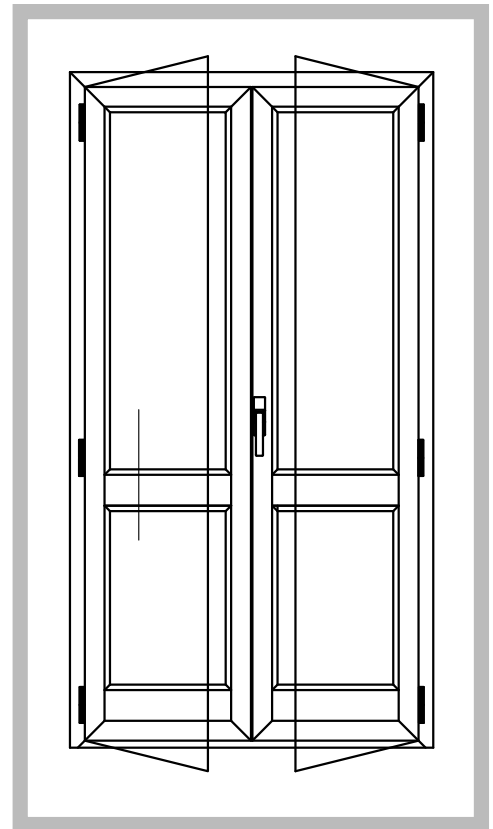



**FINESTRA**  
**BILICO ORIZZONTALE**  
HORIZONTAL PIVOT  
WINDOW

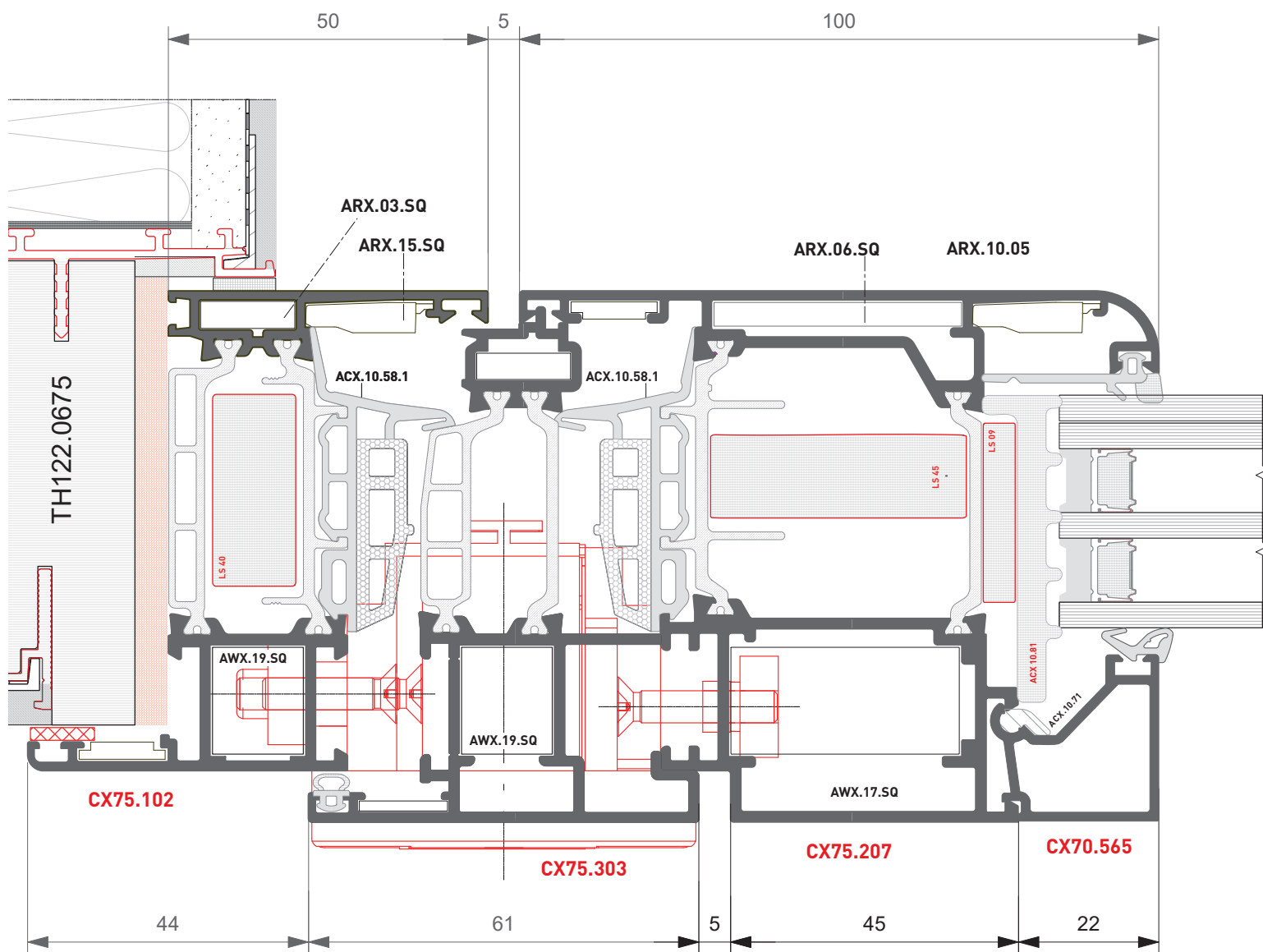
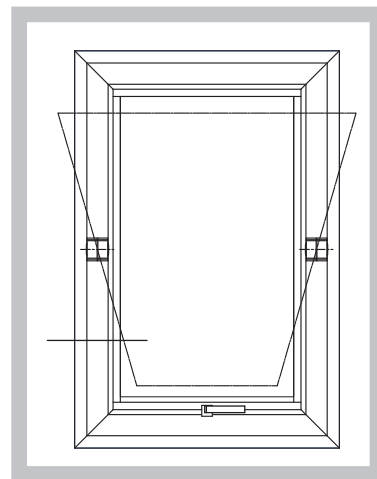

Accessorio Frizione **GU Italia U - 18/3**  
**Articolo 6 - 27212 - 07 - P**  
per accessori di movimentazione riferirsi  
alla tavola di assieme

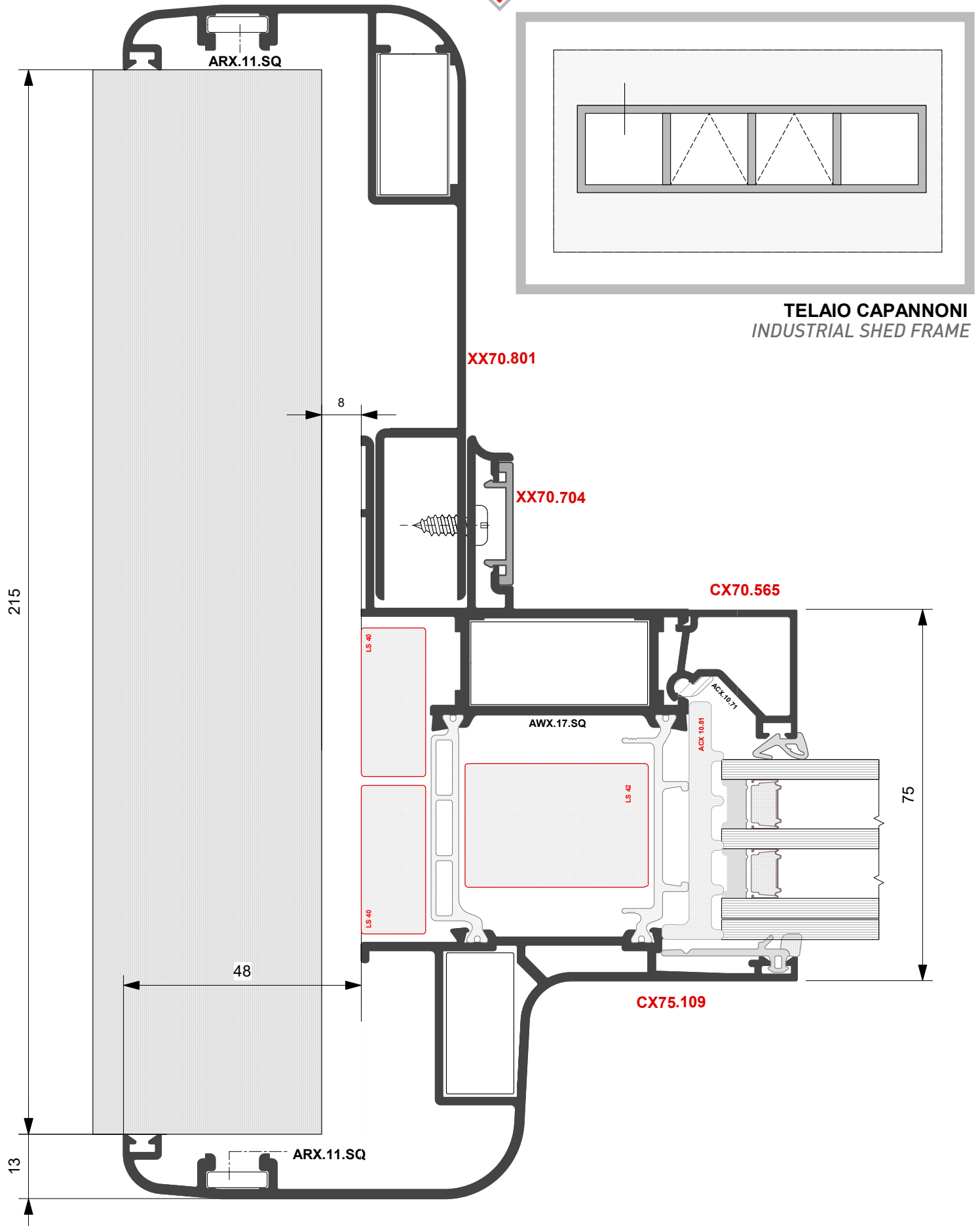

**TELAIO CAPANNONI**  
INDUSTRIAL SHED FRAME

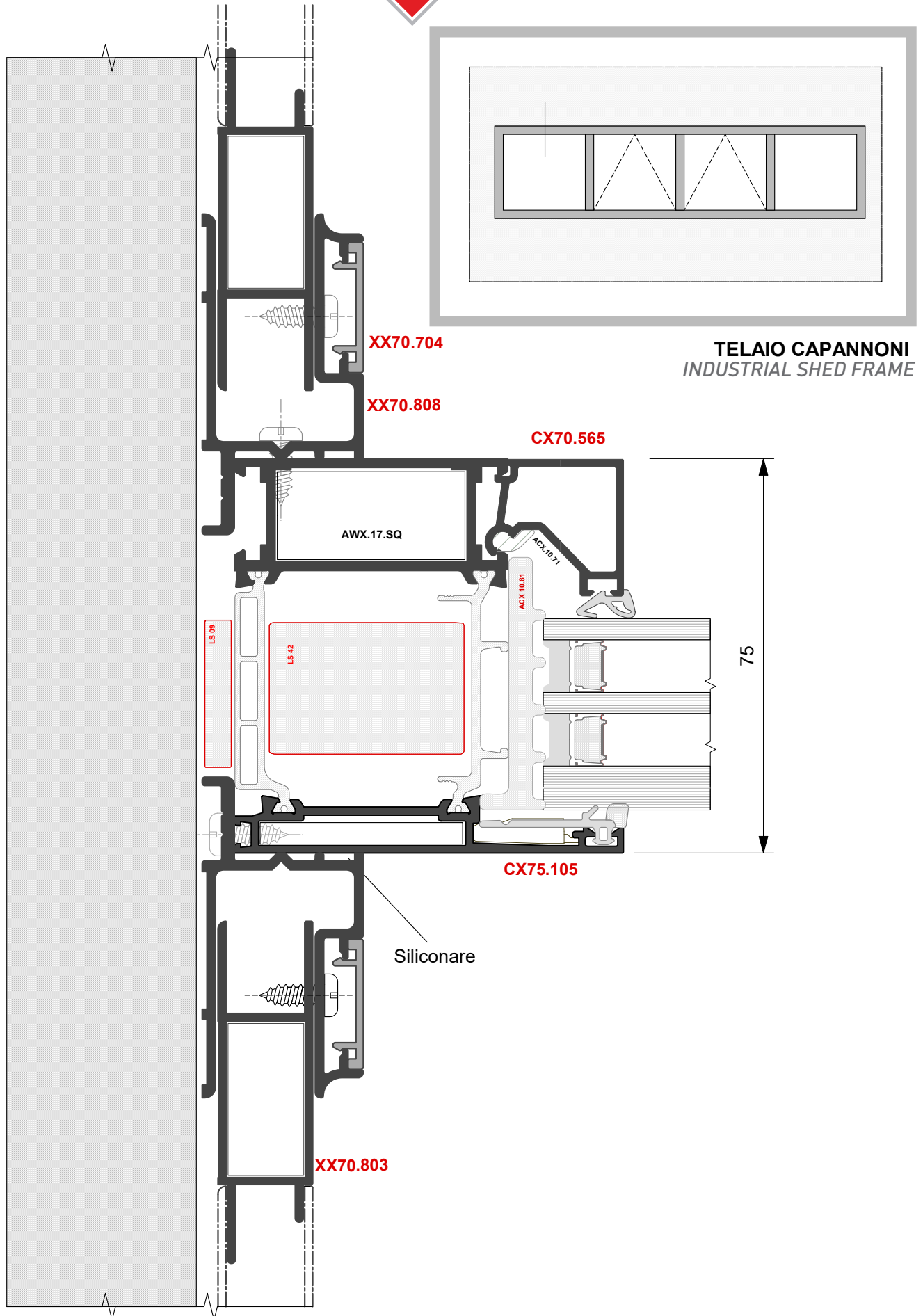

**TELAIO CAPANNONI**  
INDUSTRIAL SHED FRAME



**TELAI COMPENSAZIONE**  
LEVELLING FRAME

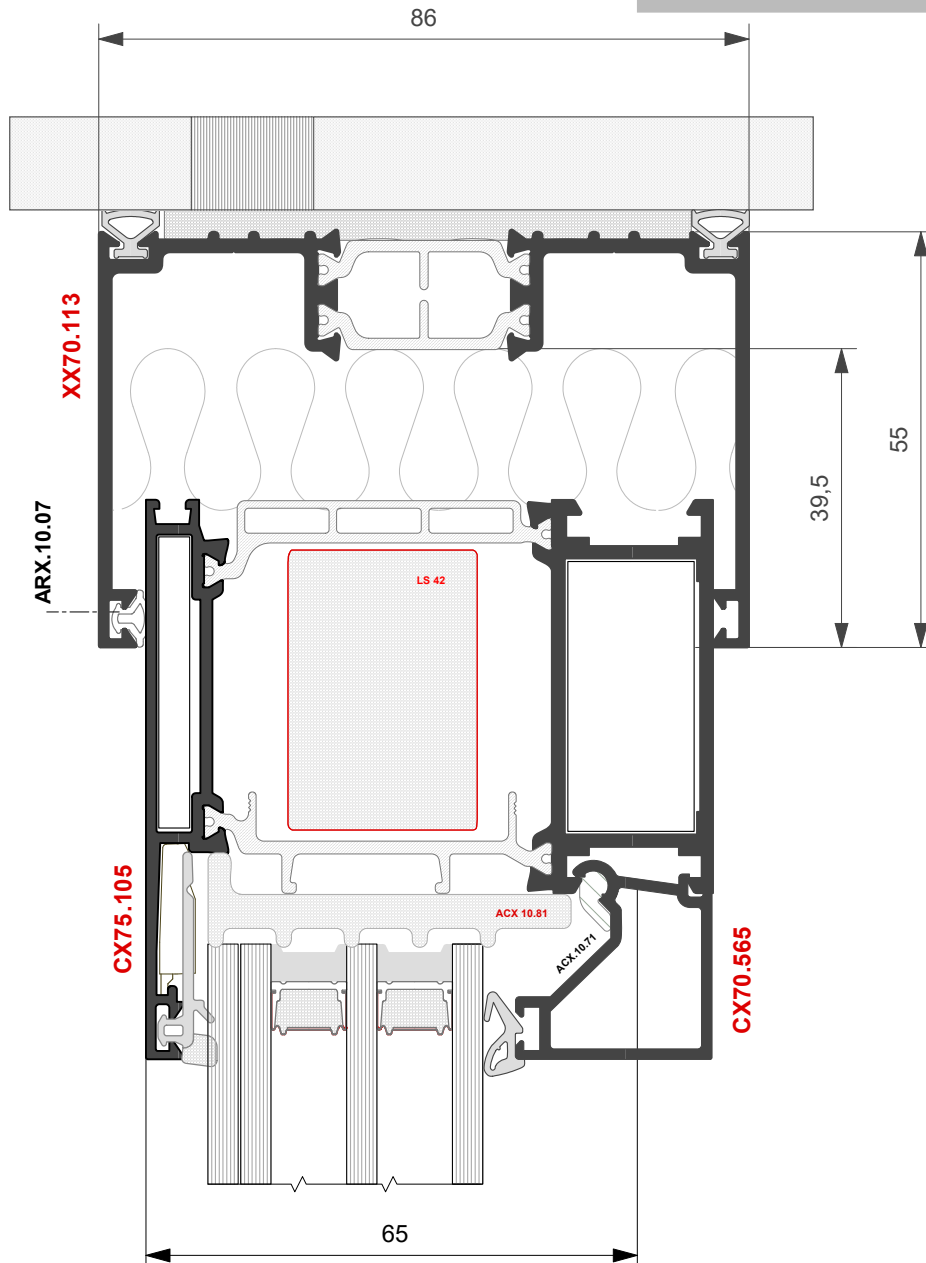
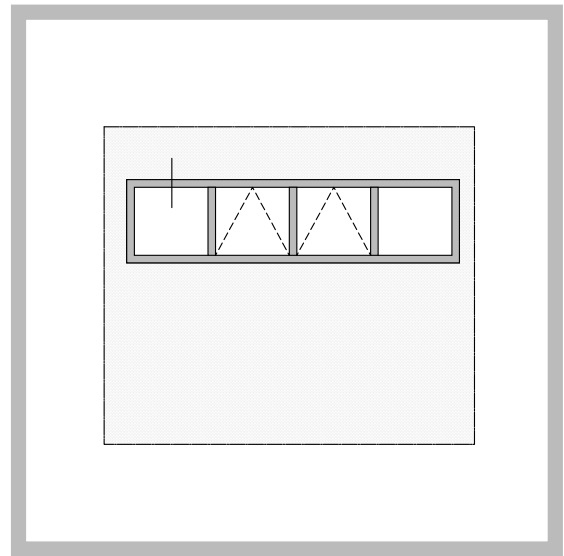



**PROFILO BATTUTA CAPANNONE**  
*SHED STOP PROFILE*

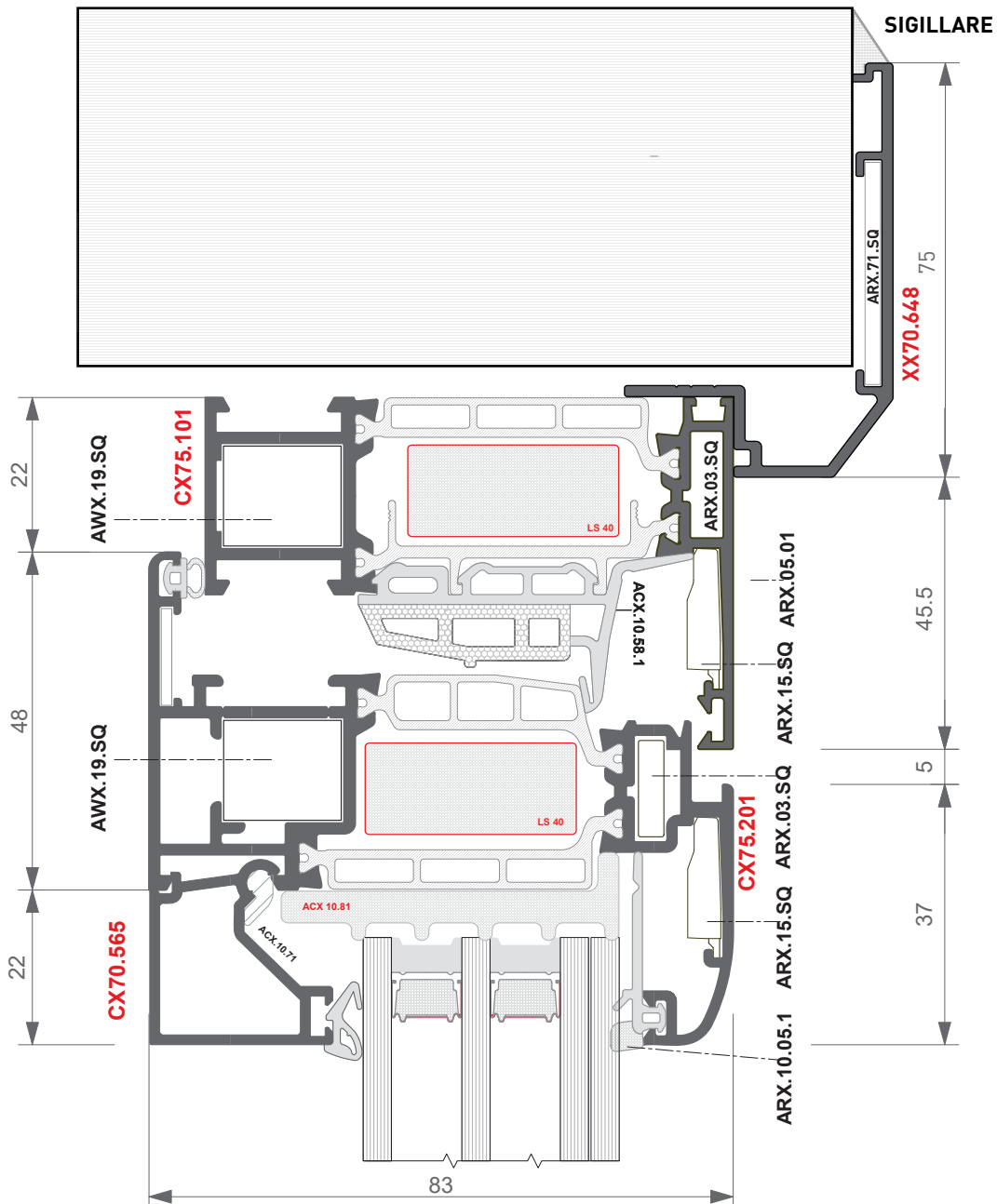
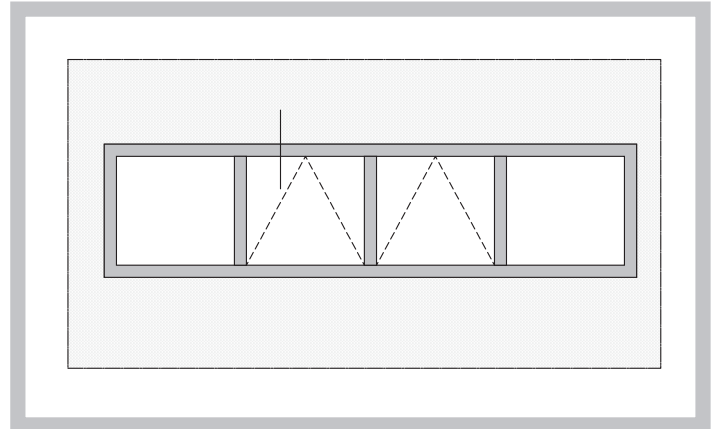



**PROFILO UNIVERSALE PER ANGOLO A 90°**  
UNIVERSAL PROFILE FOR 90° CORNER

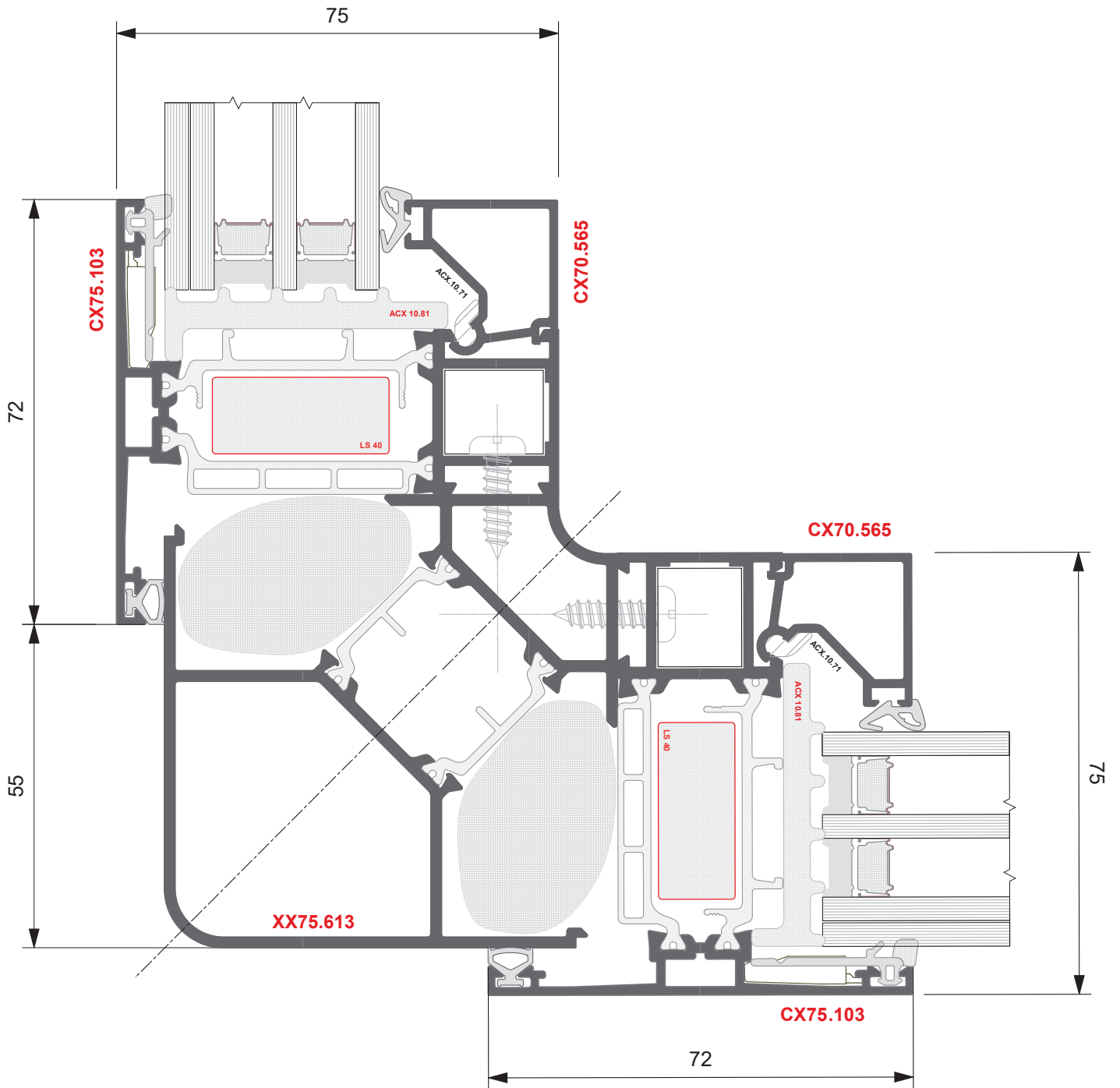



**PORTA DI INGRESSO A 2 ANTE**  
*DOUBLE SASHES ENTRANCE DOOR*

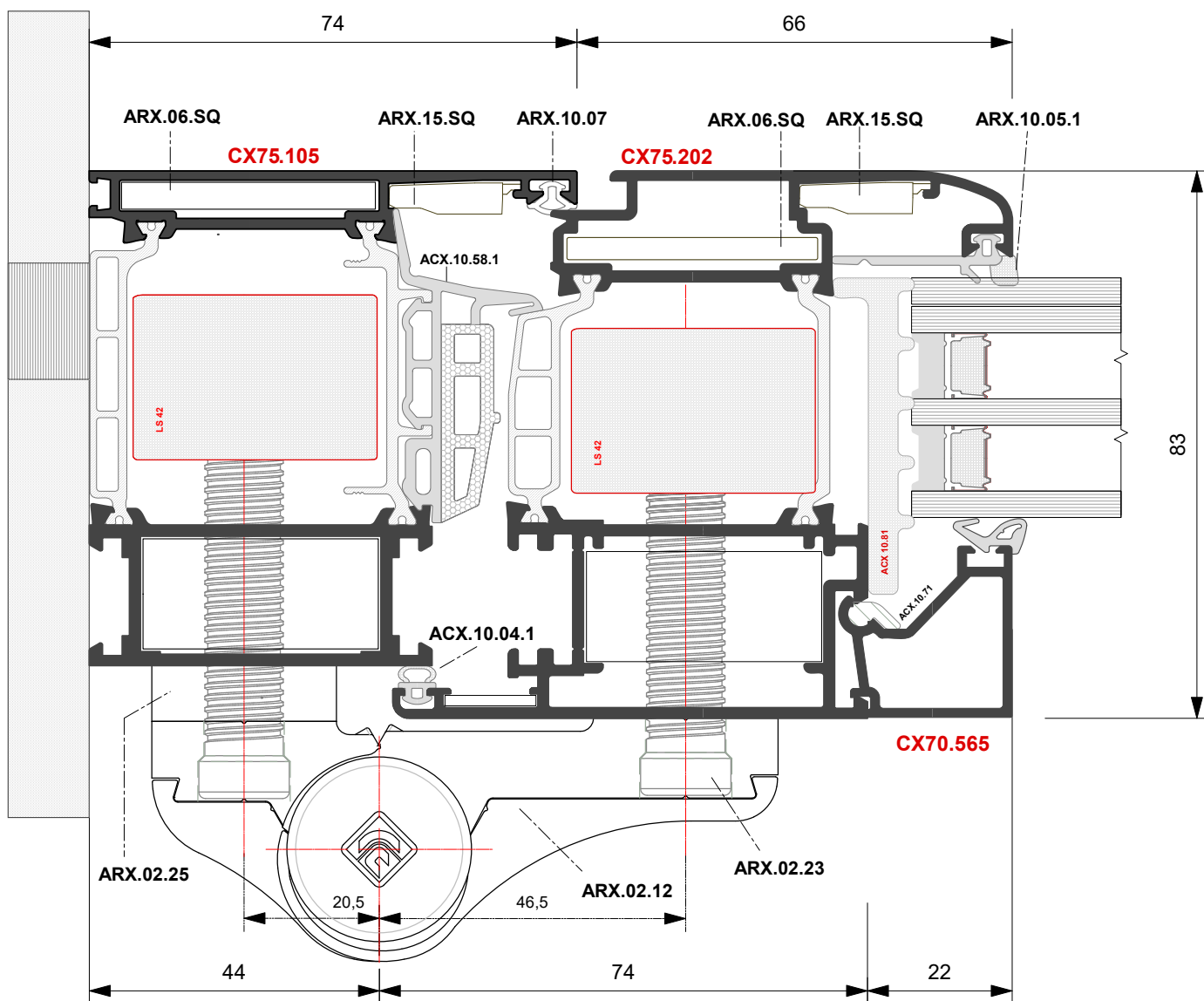
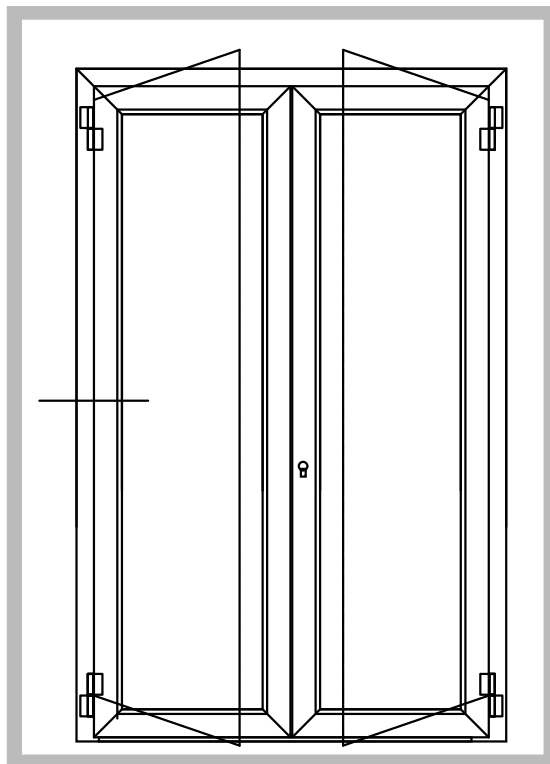

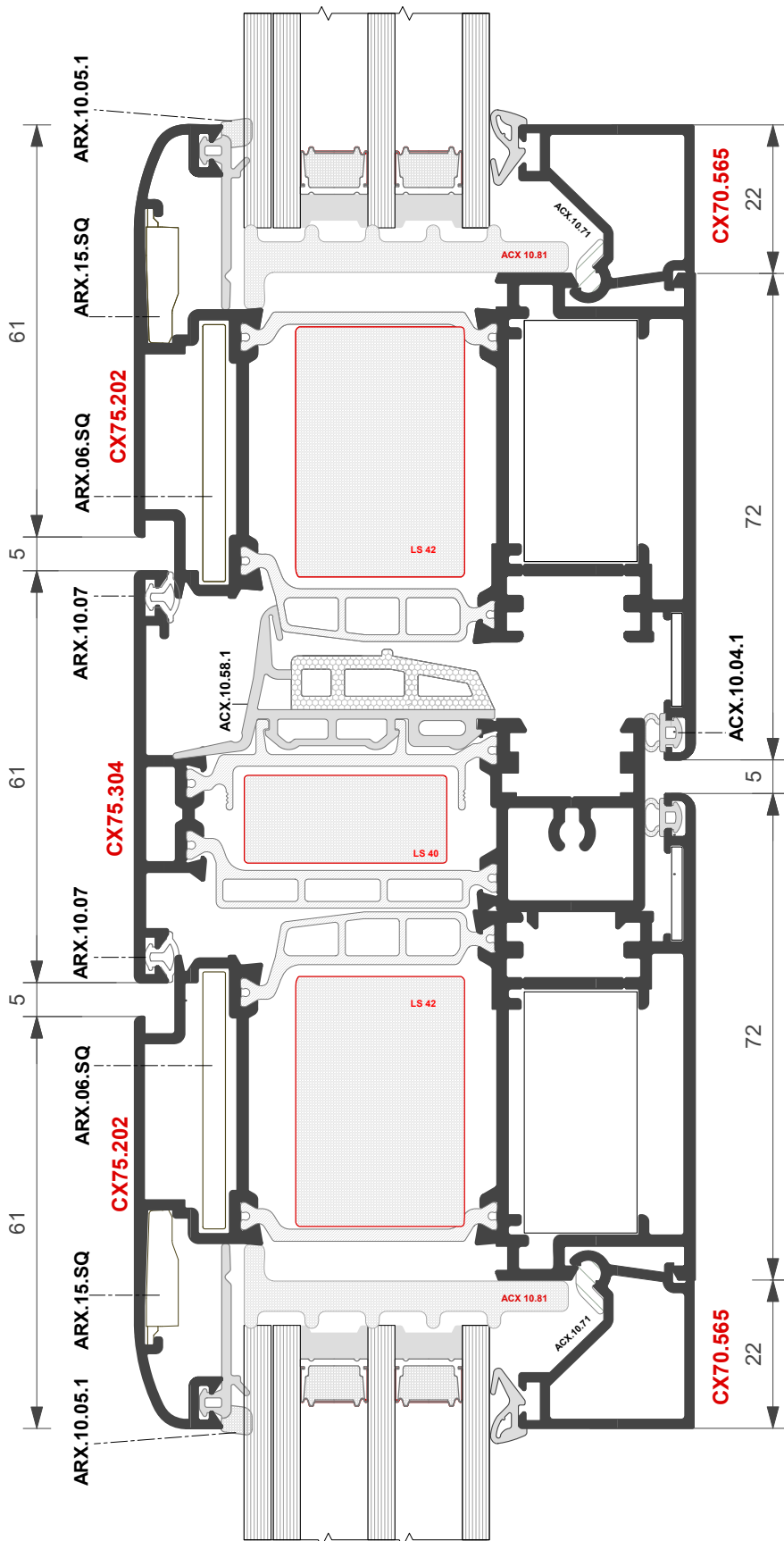

**PORTA DI INGRESSO A 2 ANTE**  
DOUBLE SASH ENTRANCE DOOR

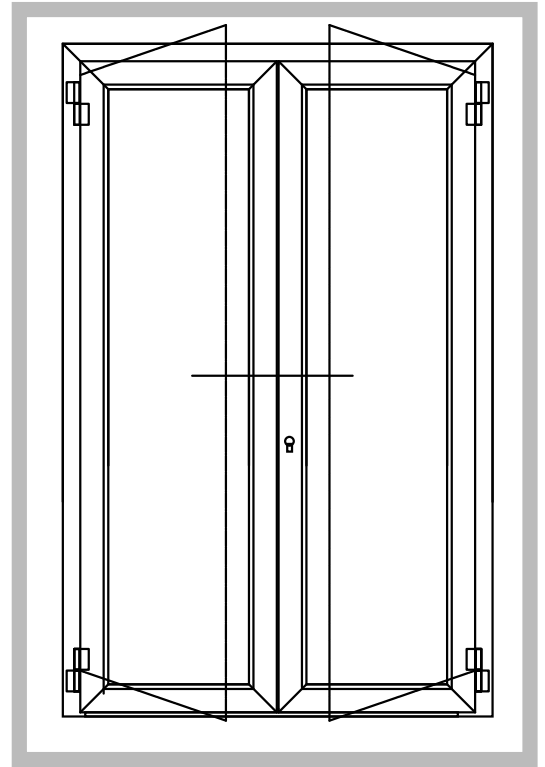



**PORTA INGRESSO AD UNA ANTA**  
*SINGLE SASH ENTRANCE DOOR*

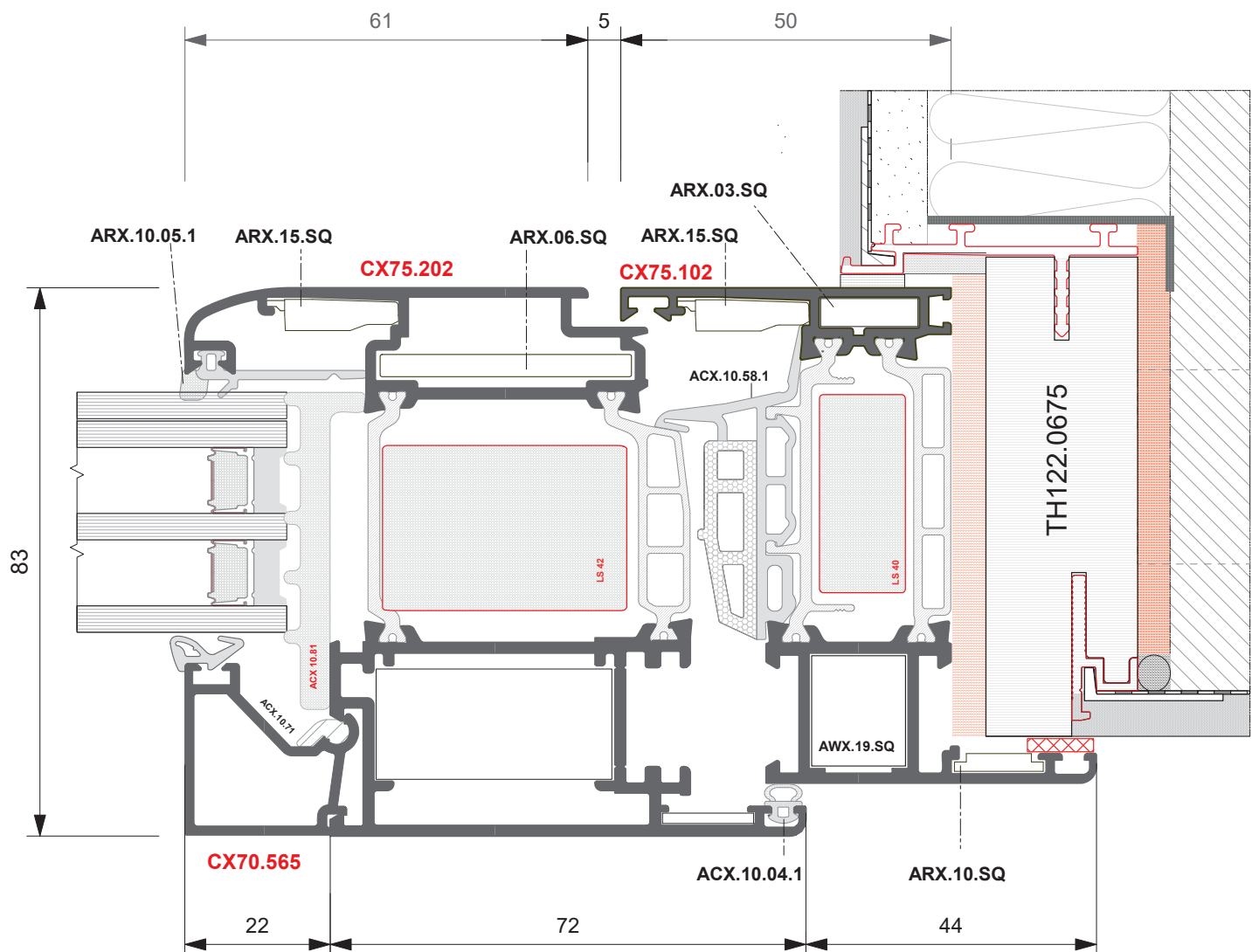
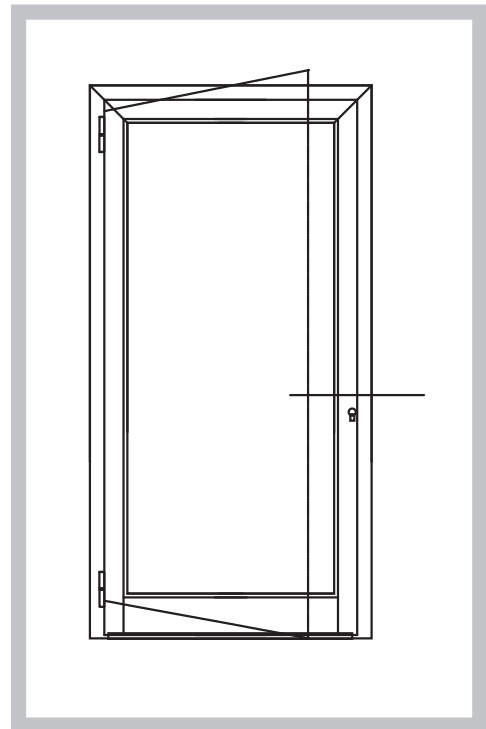



**PORTA DI INGRESSO A 2 ANTE**  
*DOUBLE SASH ENTRANCE DOOR*  
75

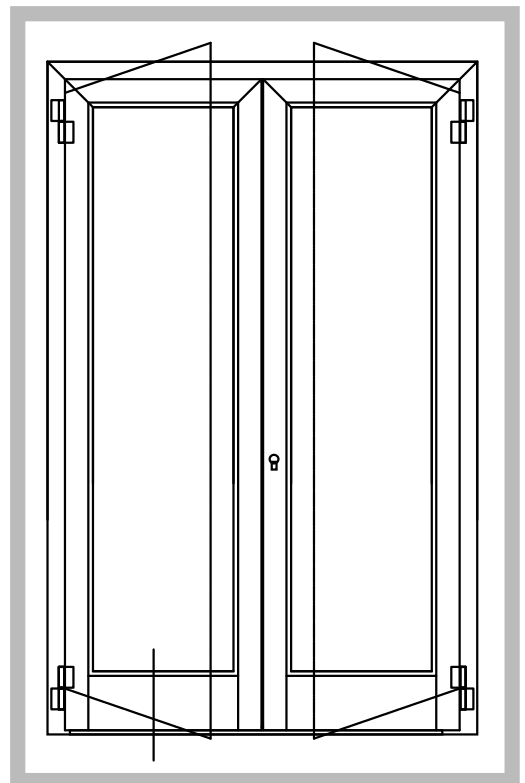
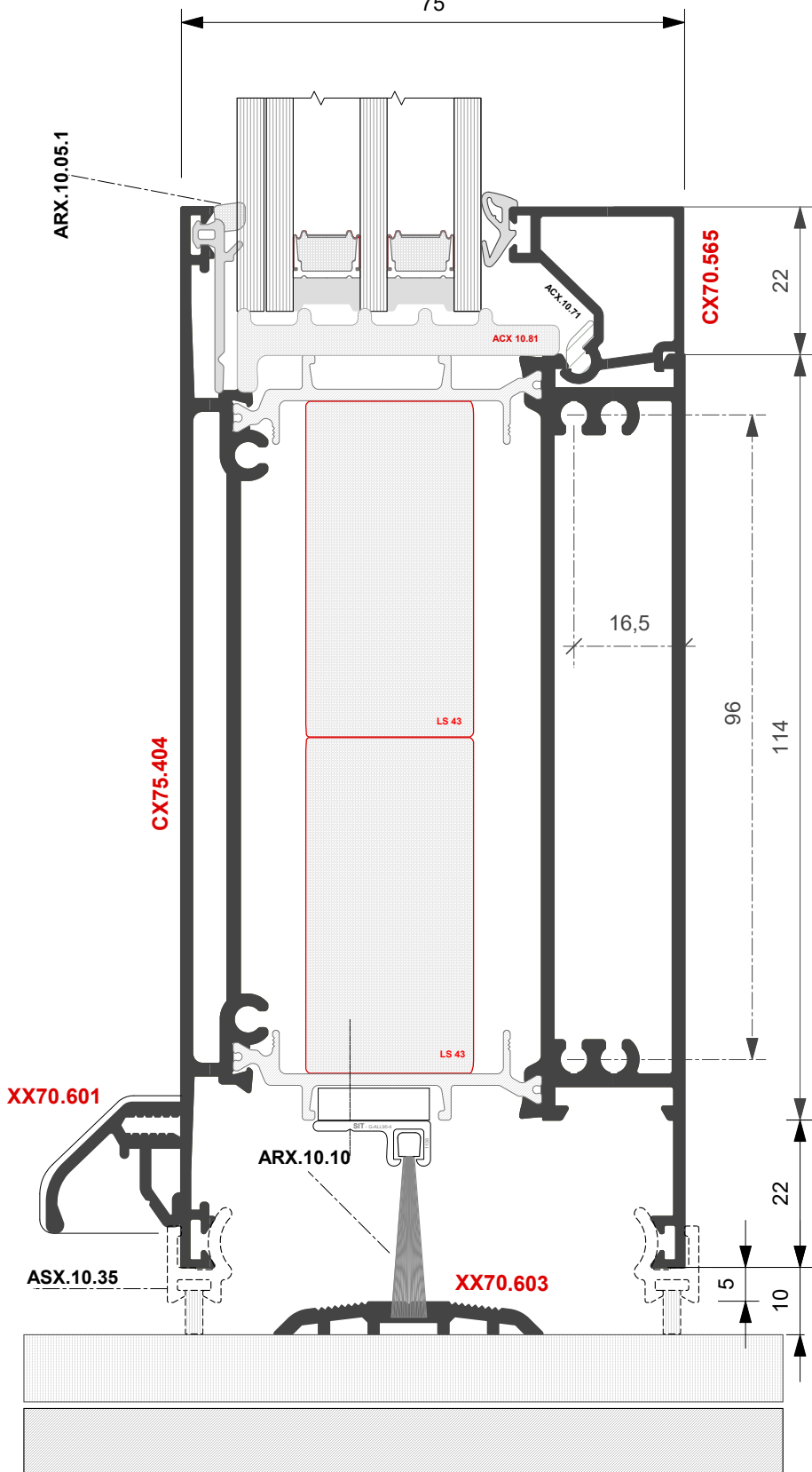



**PORTA DI INGRESSO A 2 ANTE**  
*DOUBLE SASH ENTRANCE DOOR*

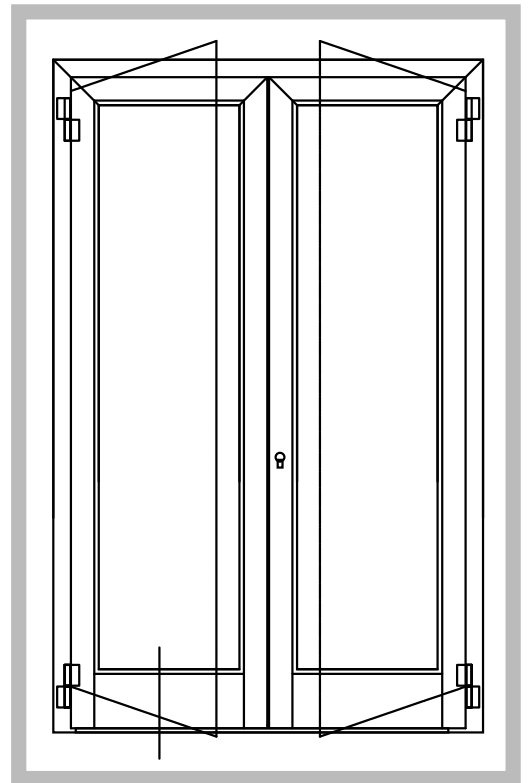
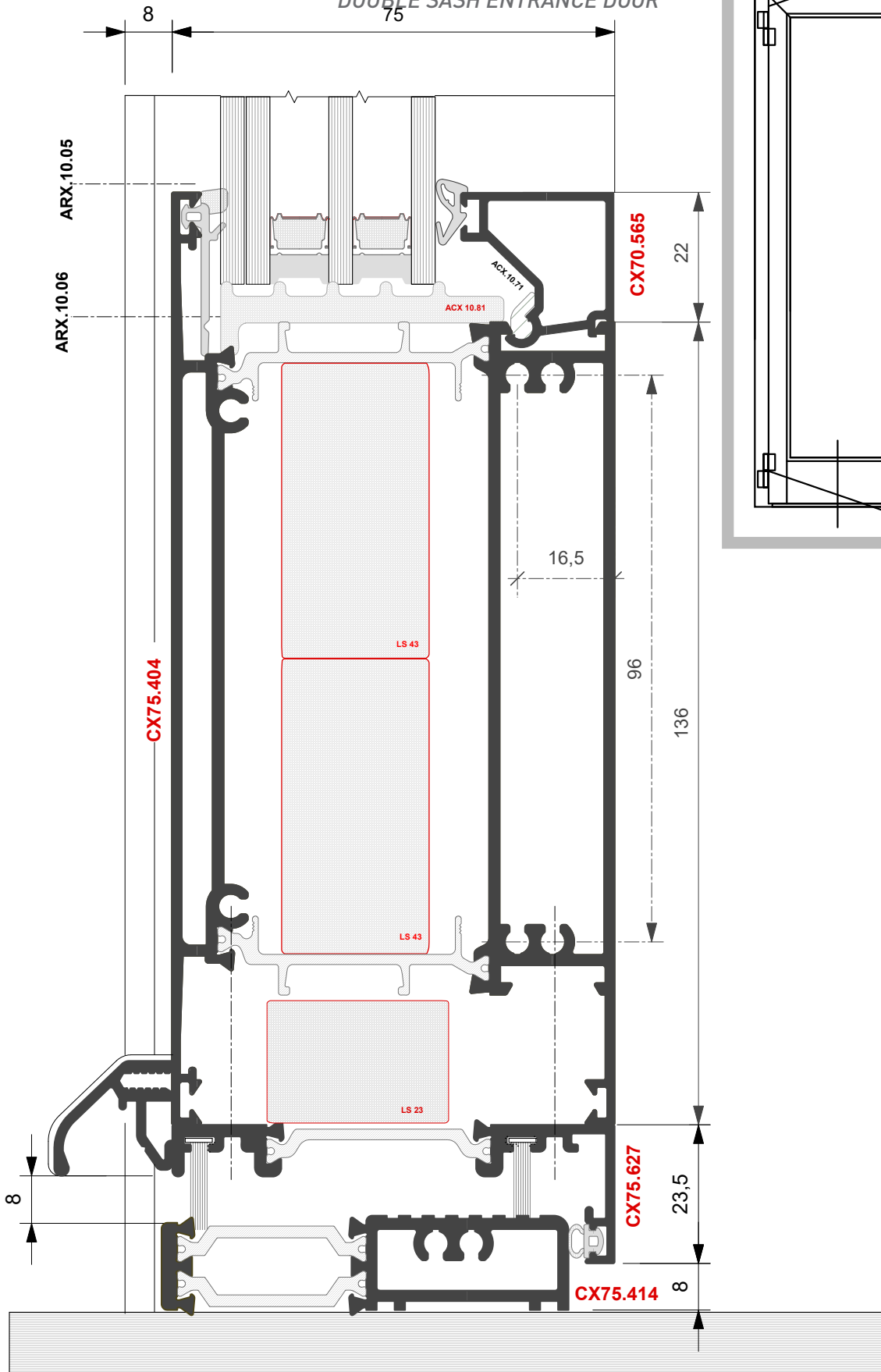

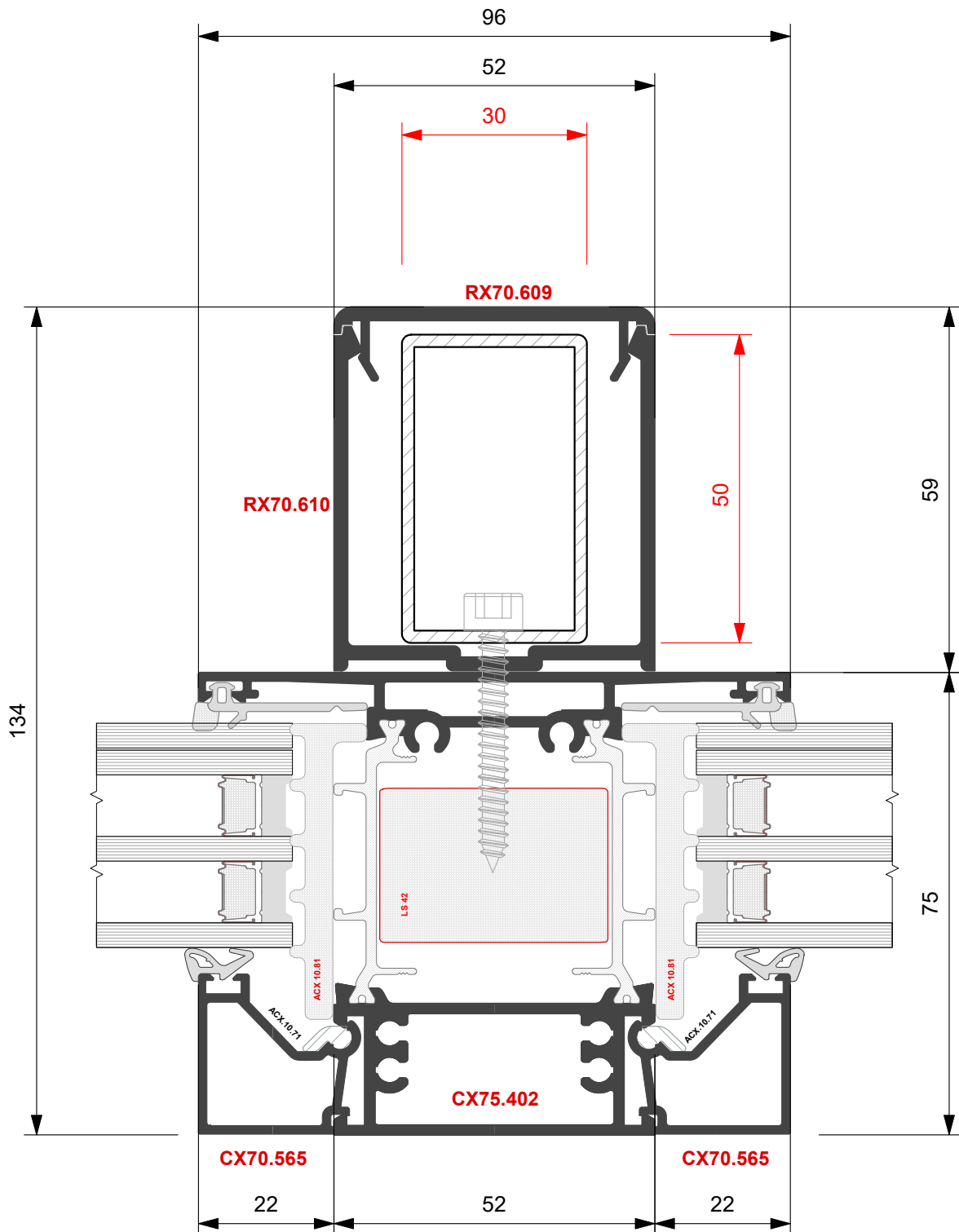

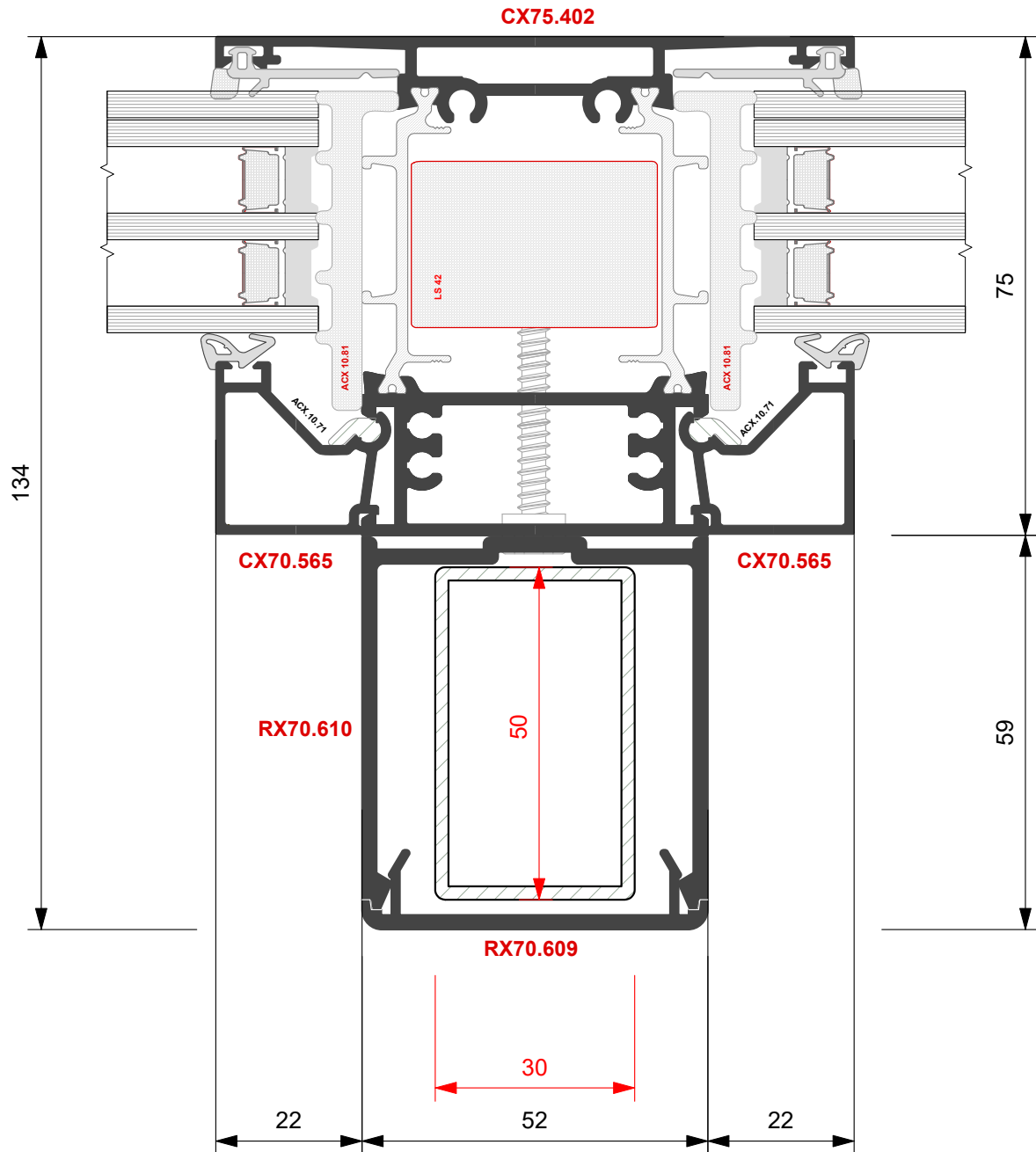

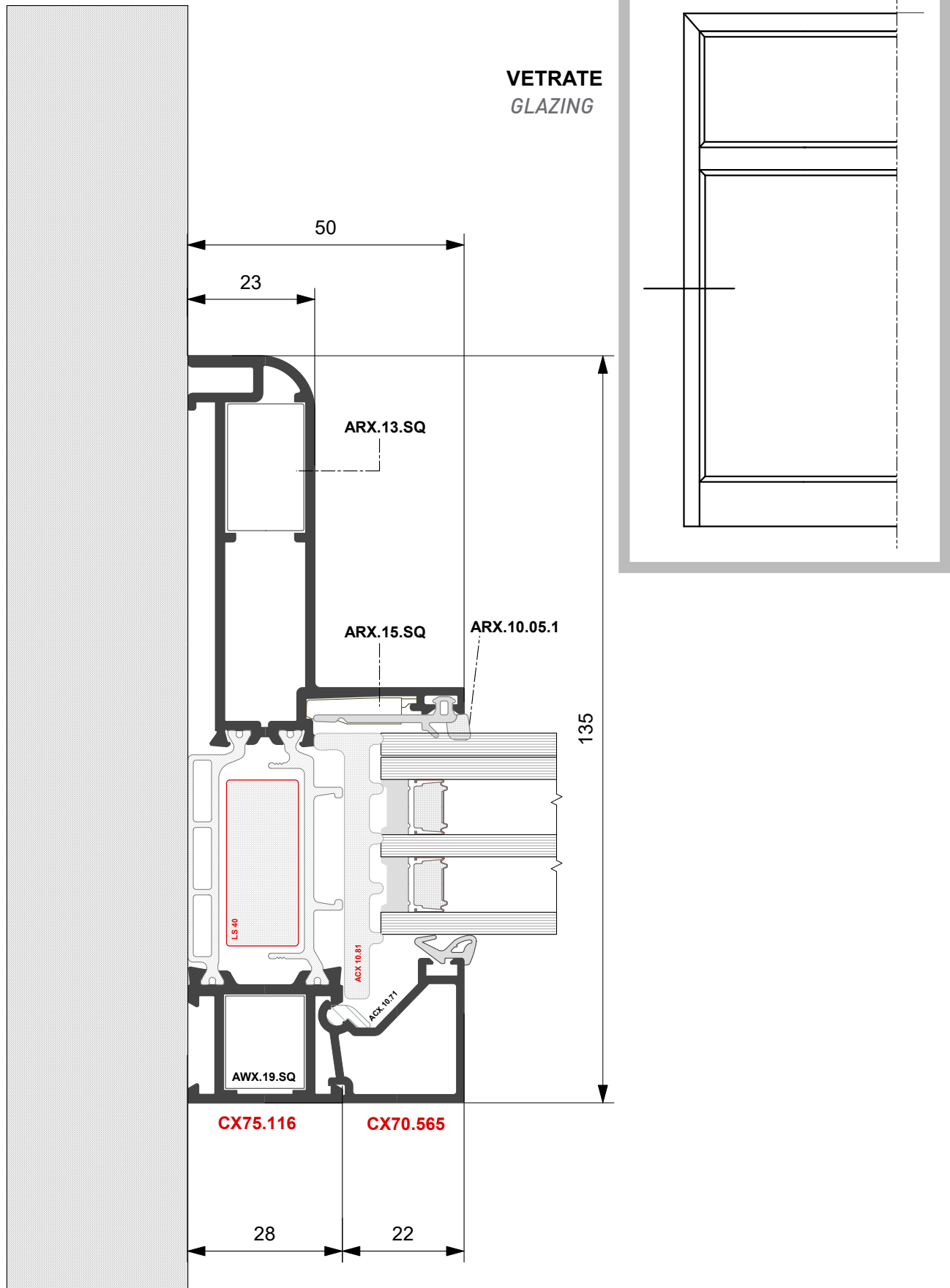



**VETRATE**  
GLAZING

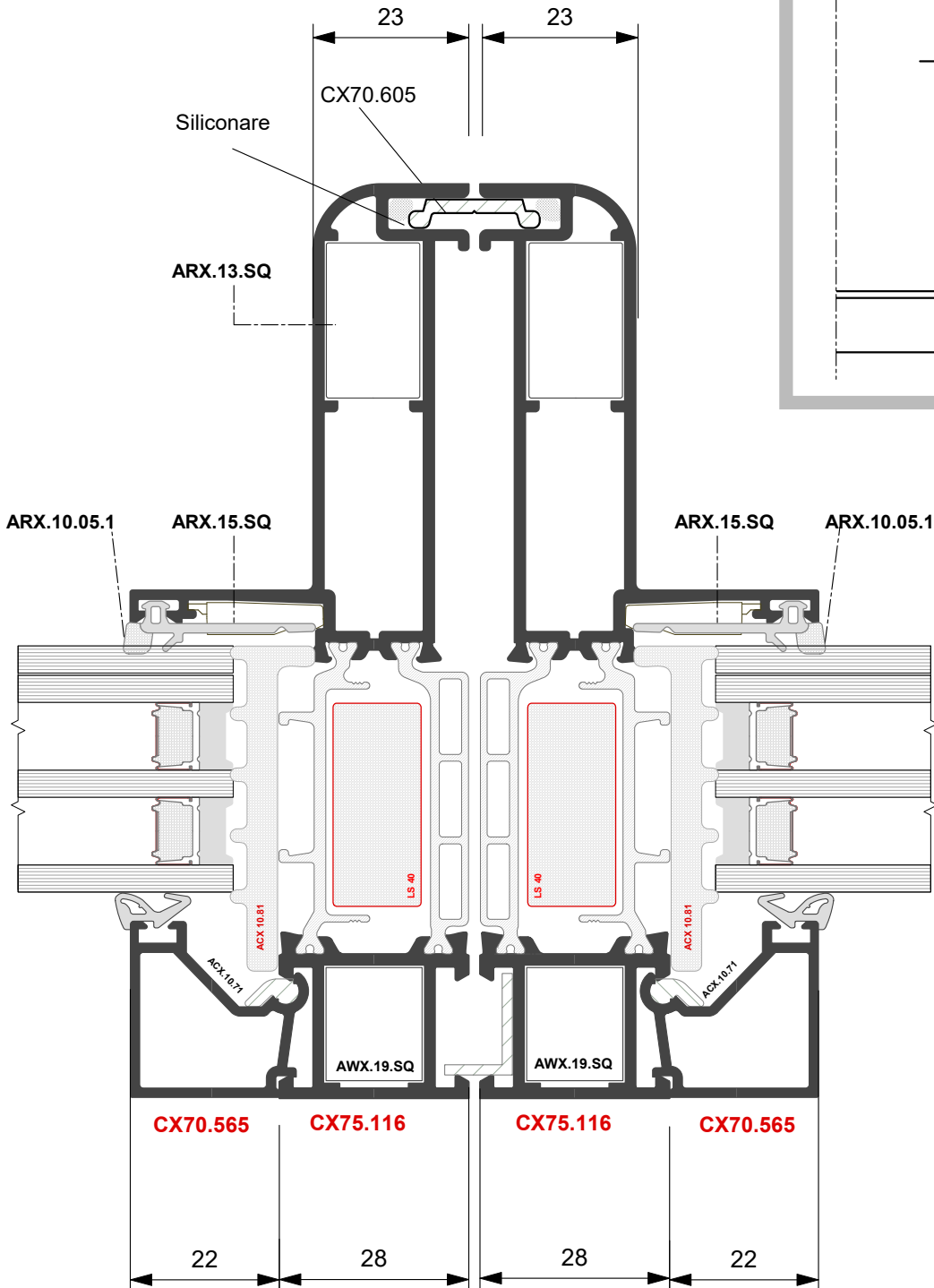
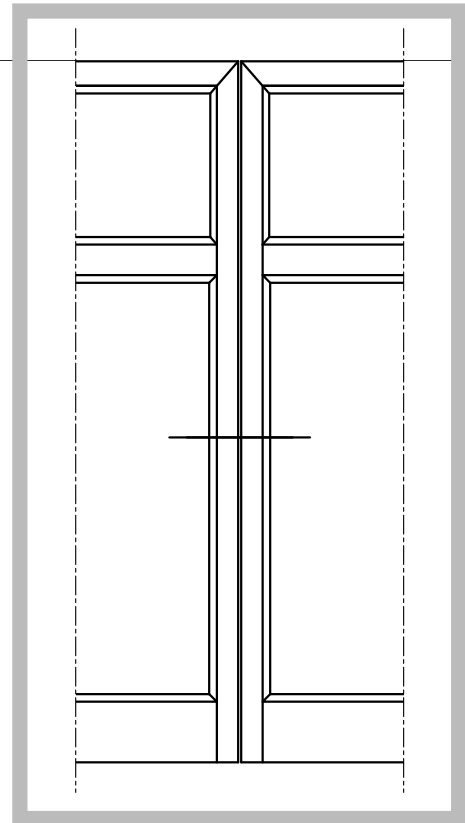



**PORTA DI INGRESSO A 2 ANTE**  
**Apertura esterna**  
*DOUBLE SASH ENTRANCE DOOR*  
*External Opening*

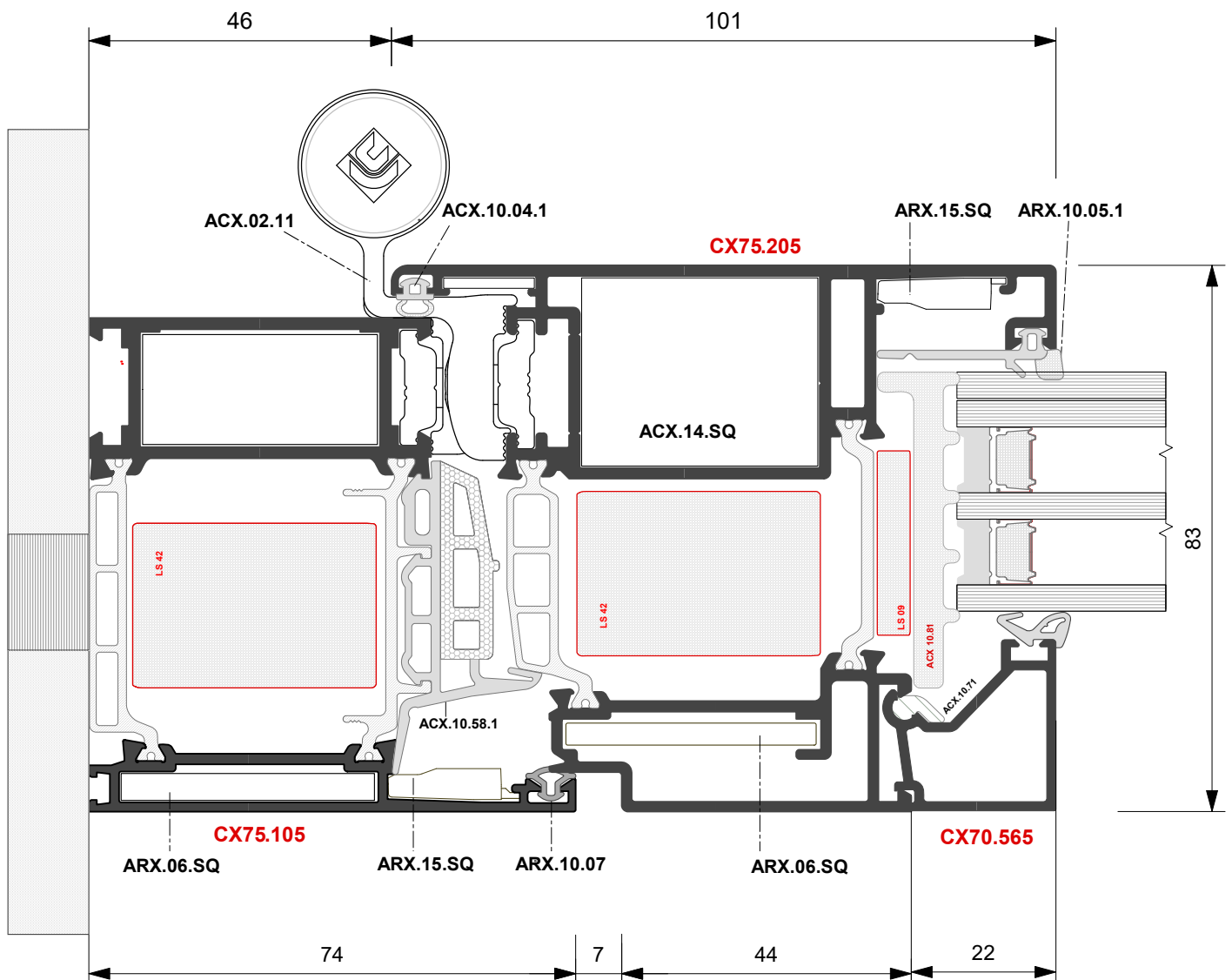
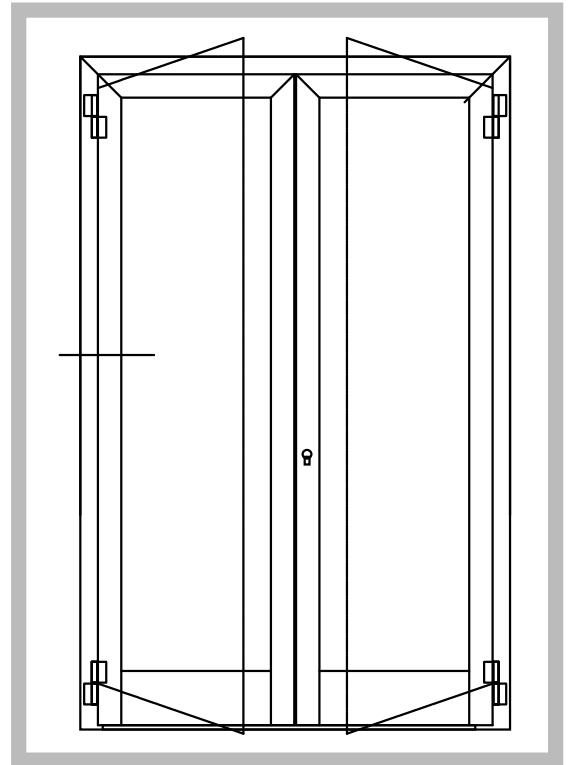



**PORTA INGRESSO AD UNA ANTA**  
**Apertura esterna**

*SINGLE SASH ENTRANCE DOOR*  
*External Opening*

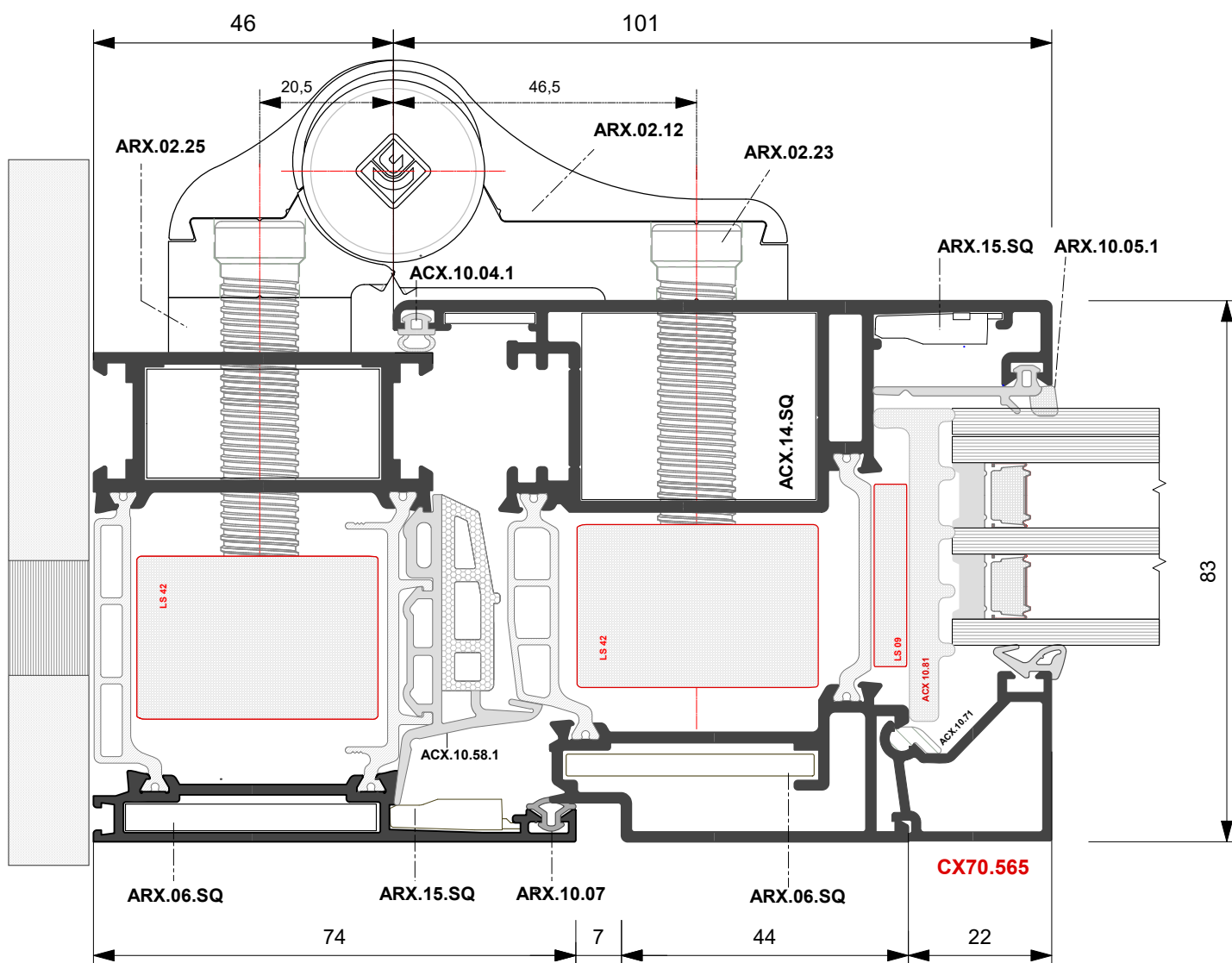
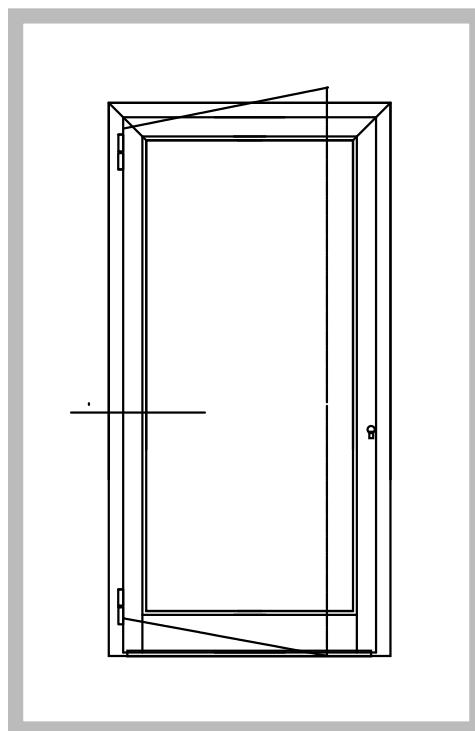



**PORTA INGRESSO AD UNA ANTA**  
**Apertura esterna**  
*SINGLE SASH ENTRANCE DOOR*  
*External Opening*

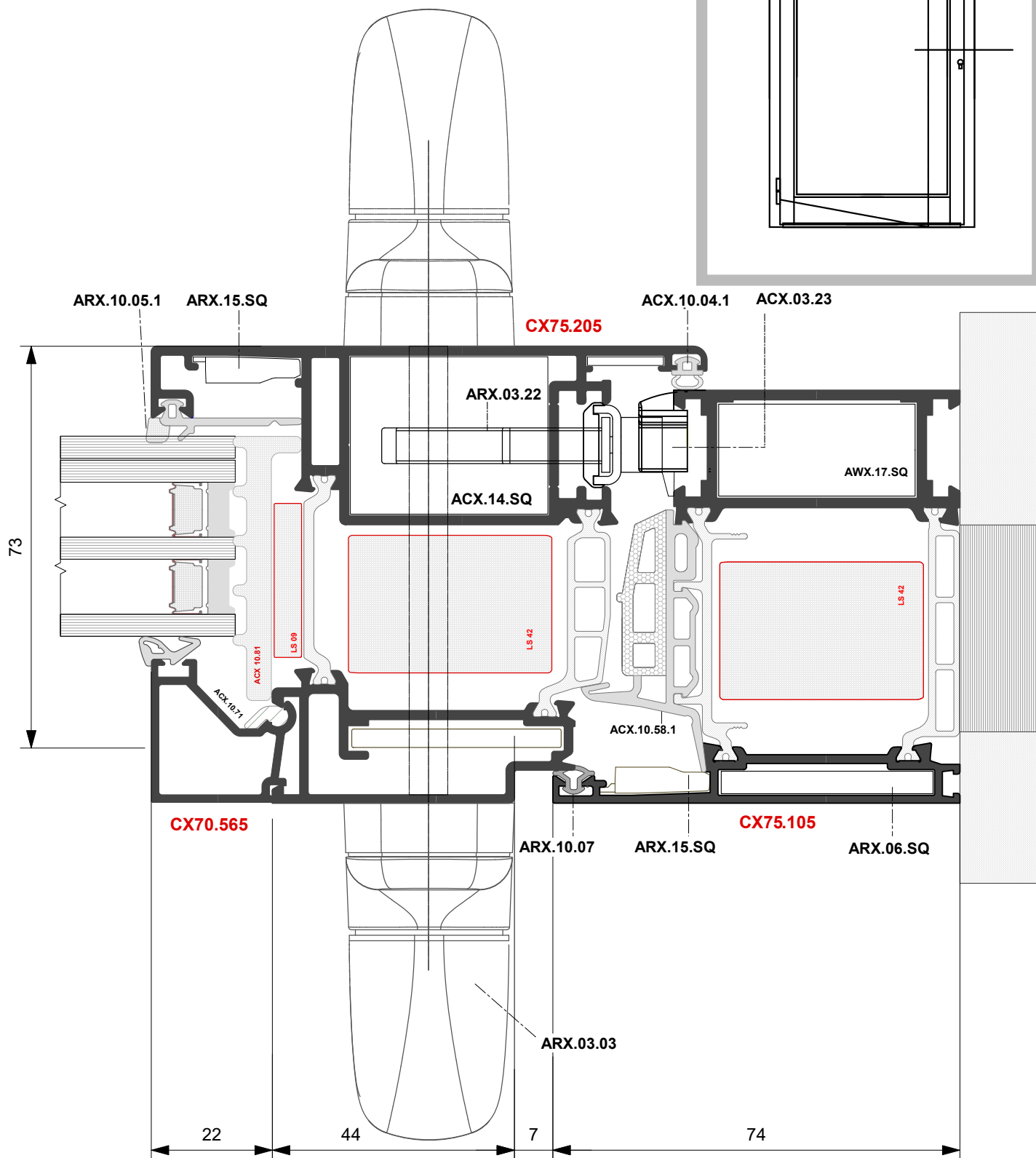
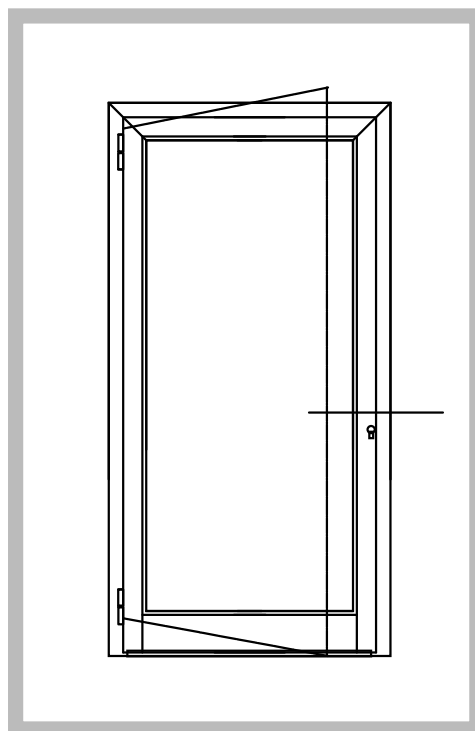

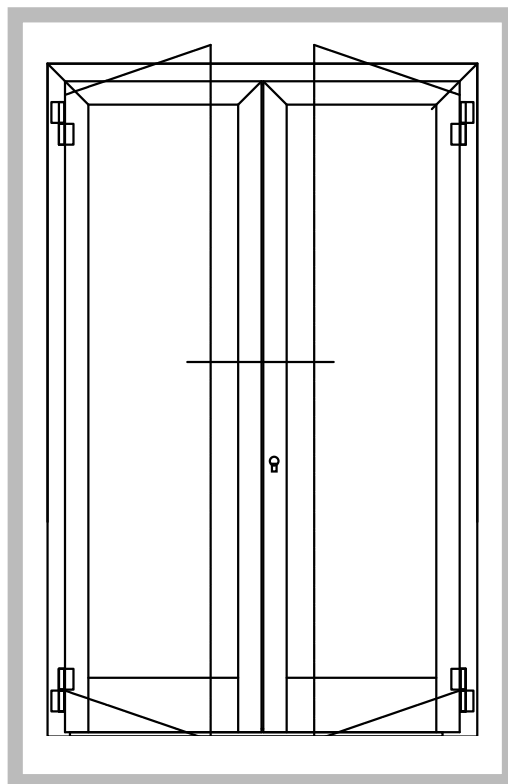
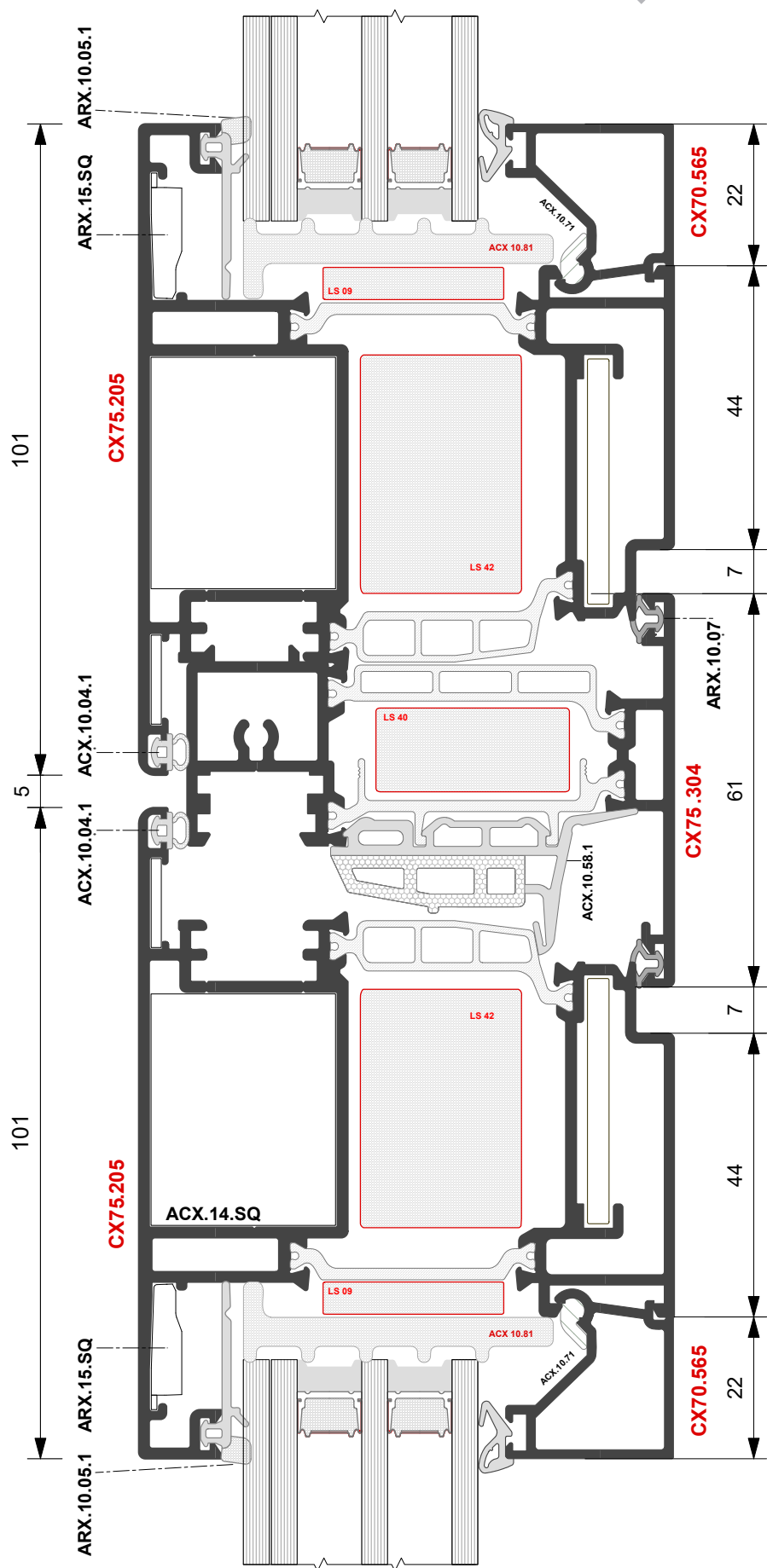

**PORTA INGRESSO AD DUE ANTE**  
**Apertura esterna**  
*DOUBLE SASH ENTRANCE DOOR*  
*External Opening*



**PORTA DI INGRESSO A 3 ANTE**  
**Apertura esterna**  
**3 SASHES ENTRANCE DOOR**  
*External Opening*

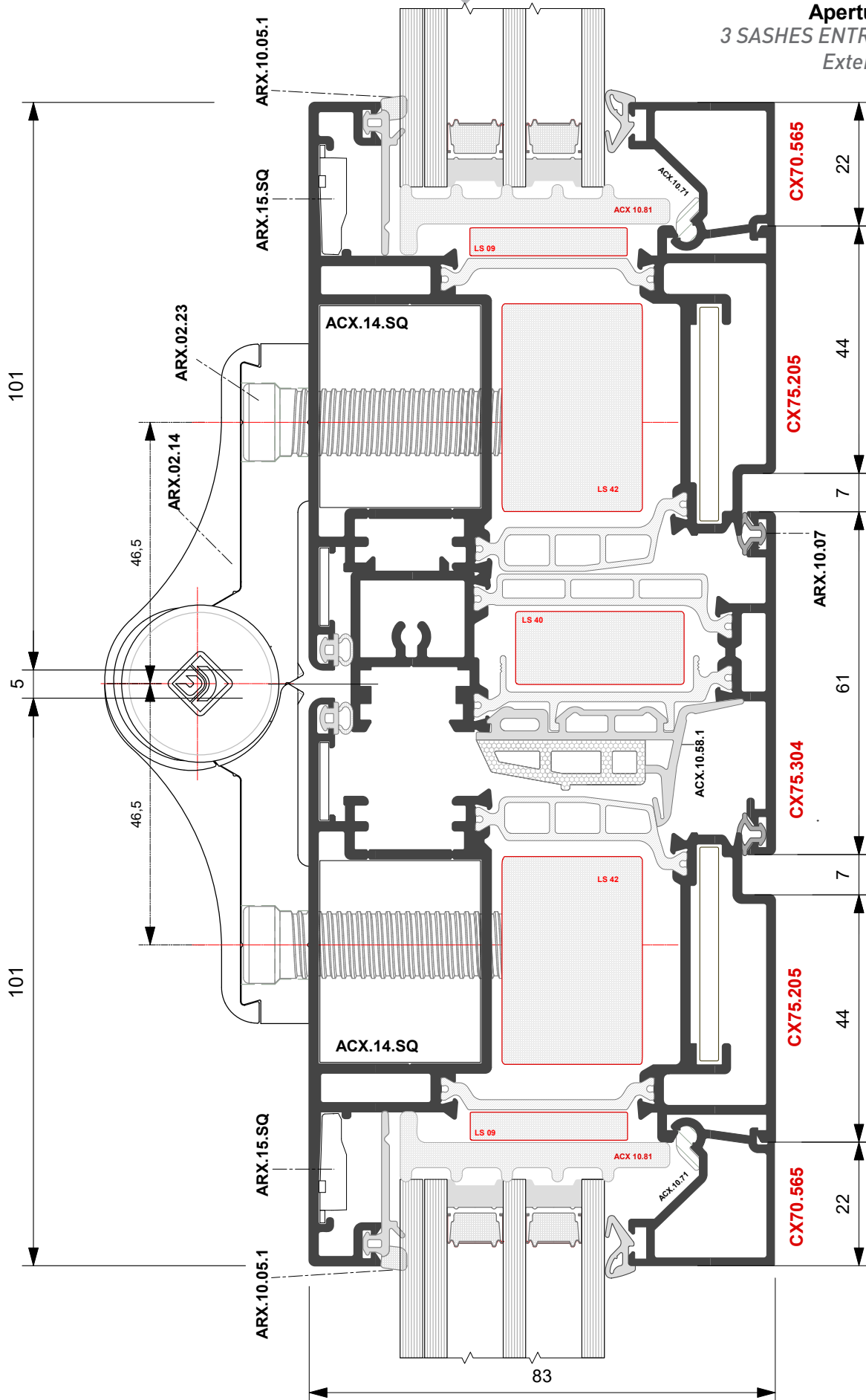

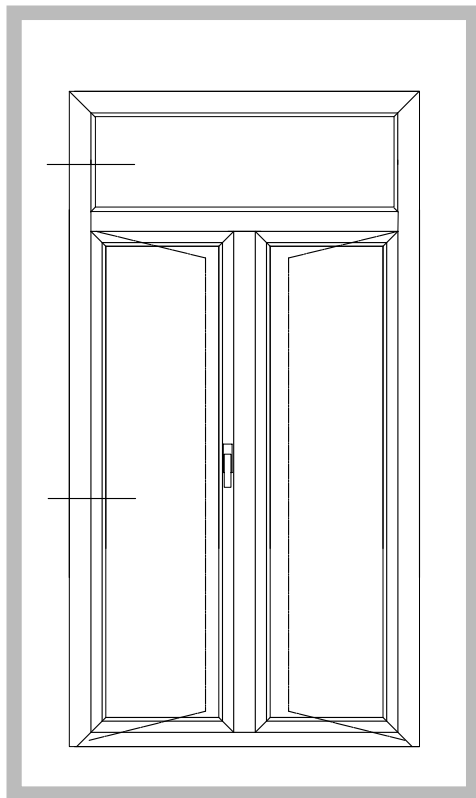
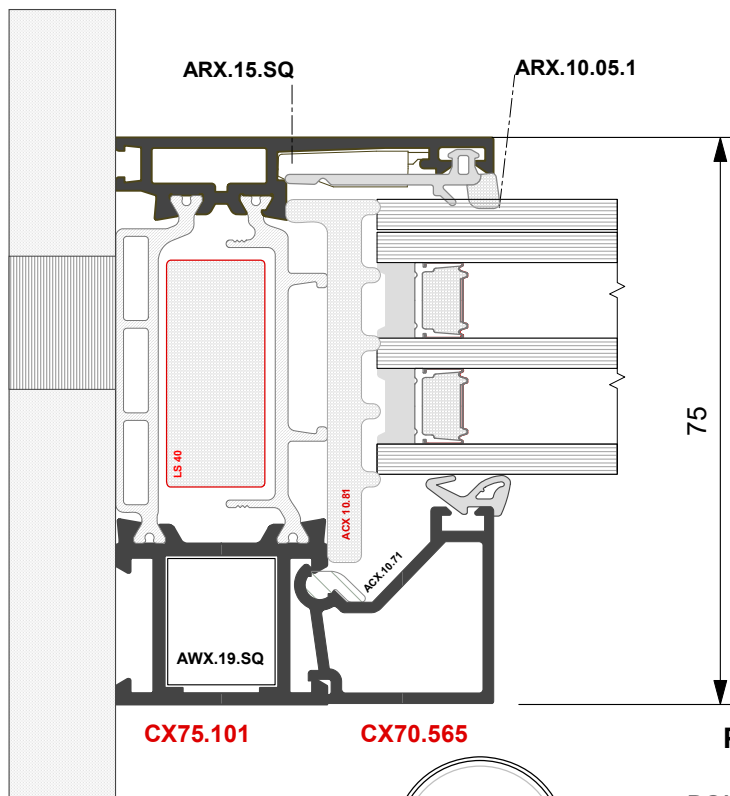

**PORTA A DUE ANTE CON SOPRALUCE FISSO**

**Apertura esterna**

*DOUBLE SASH WINDOW + FIXED FANLIGHT TRANSOM*

*External Opening*

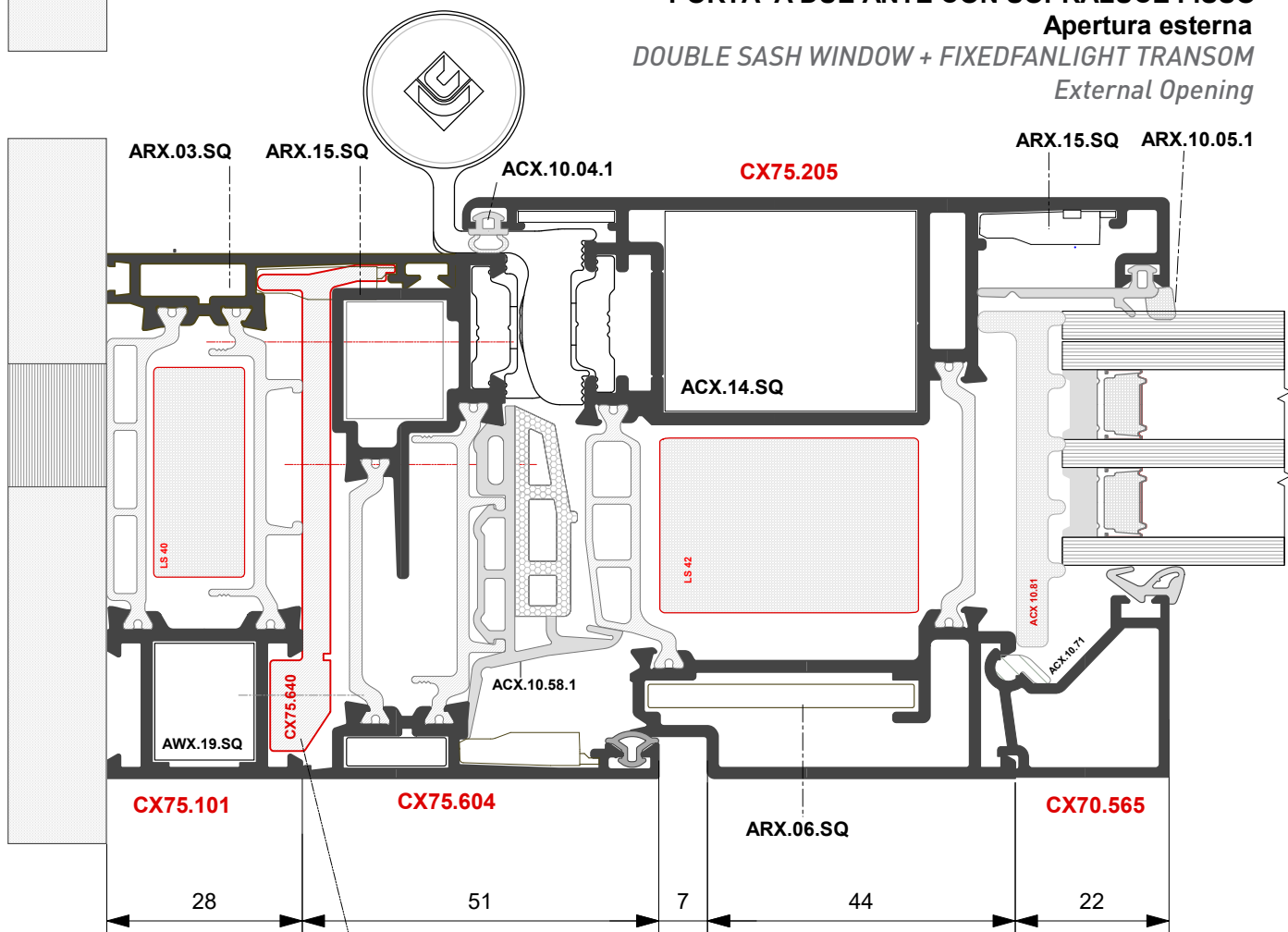

Utilizzare a pezzi in corrispondenza fissaggi.



**PORTA INGRESSO A DUE ANTE**  
**Apertura interna**  
*DOUBLE SASH ENTRANCE DOOR*  
*Internal Opening*

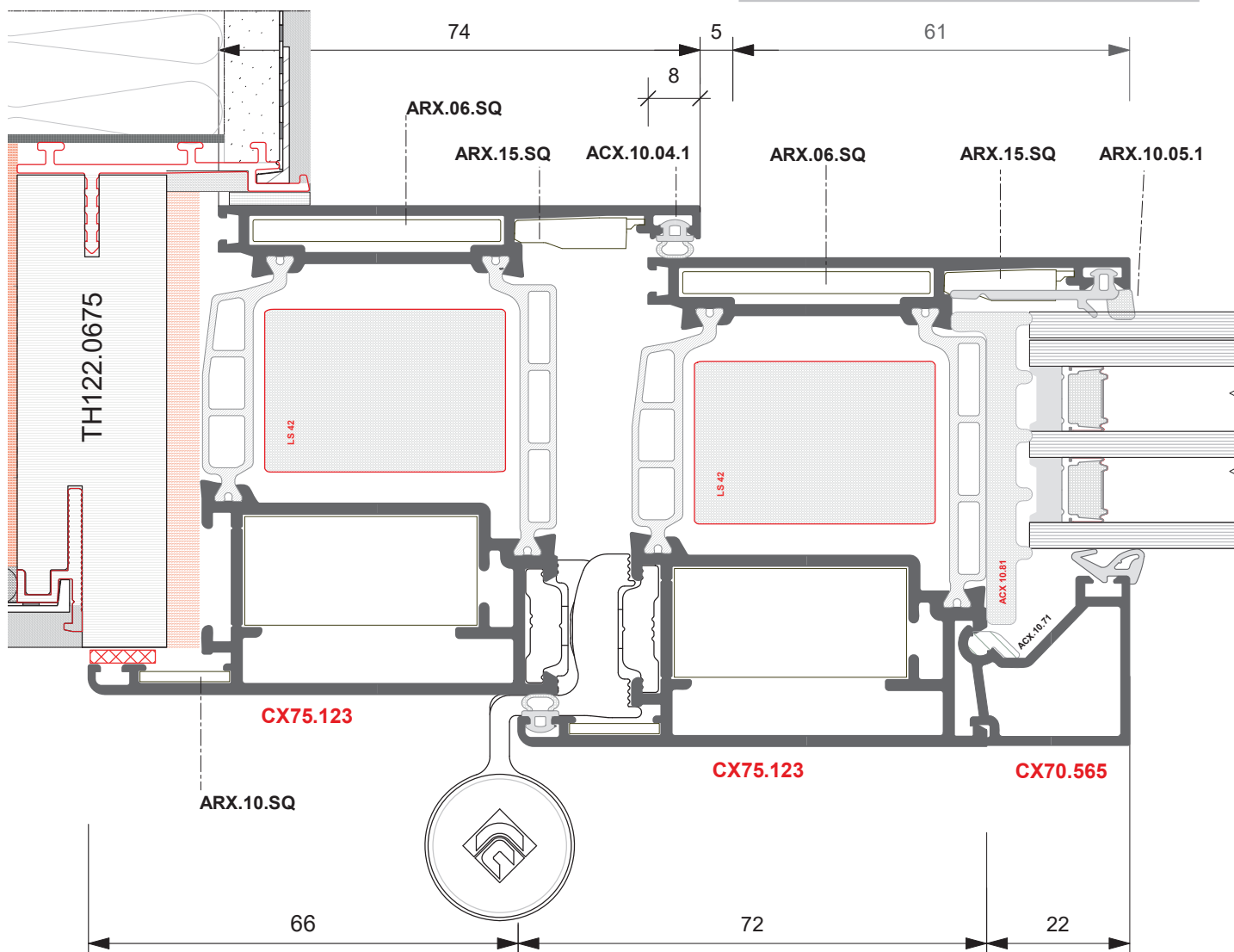
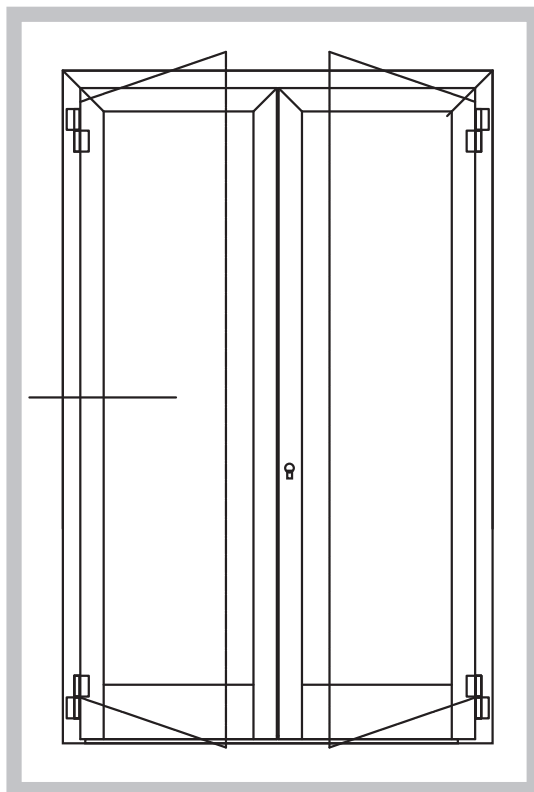

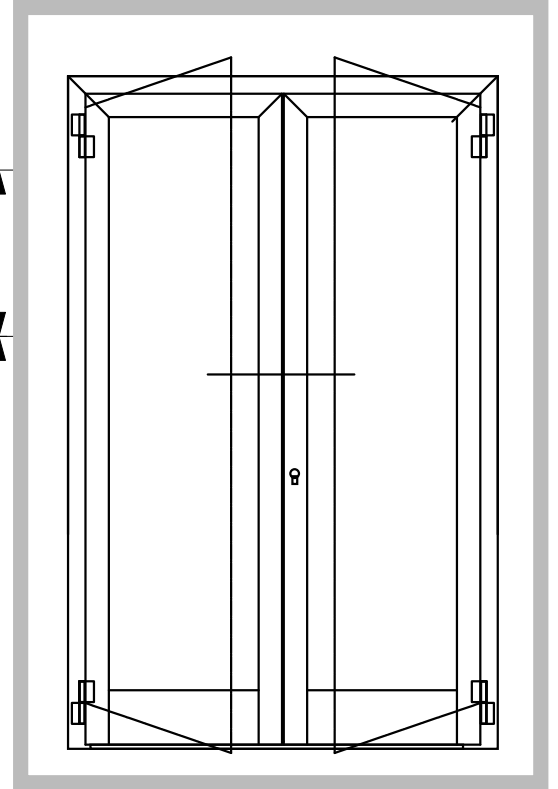
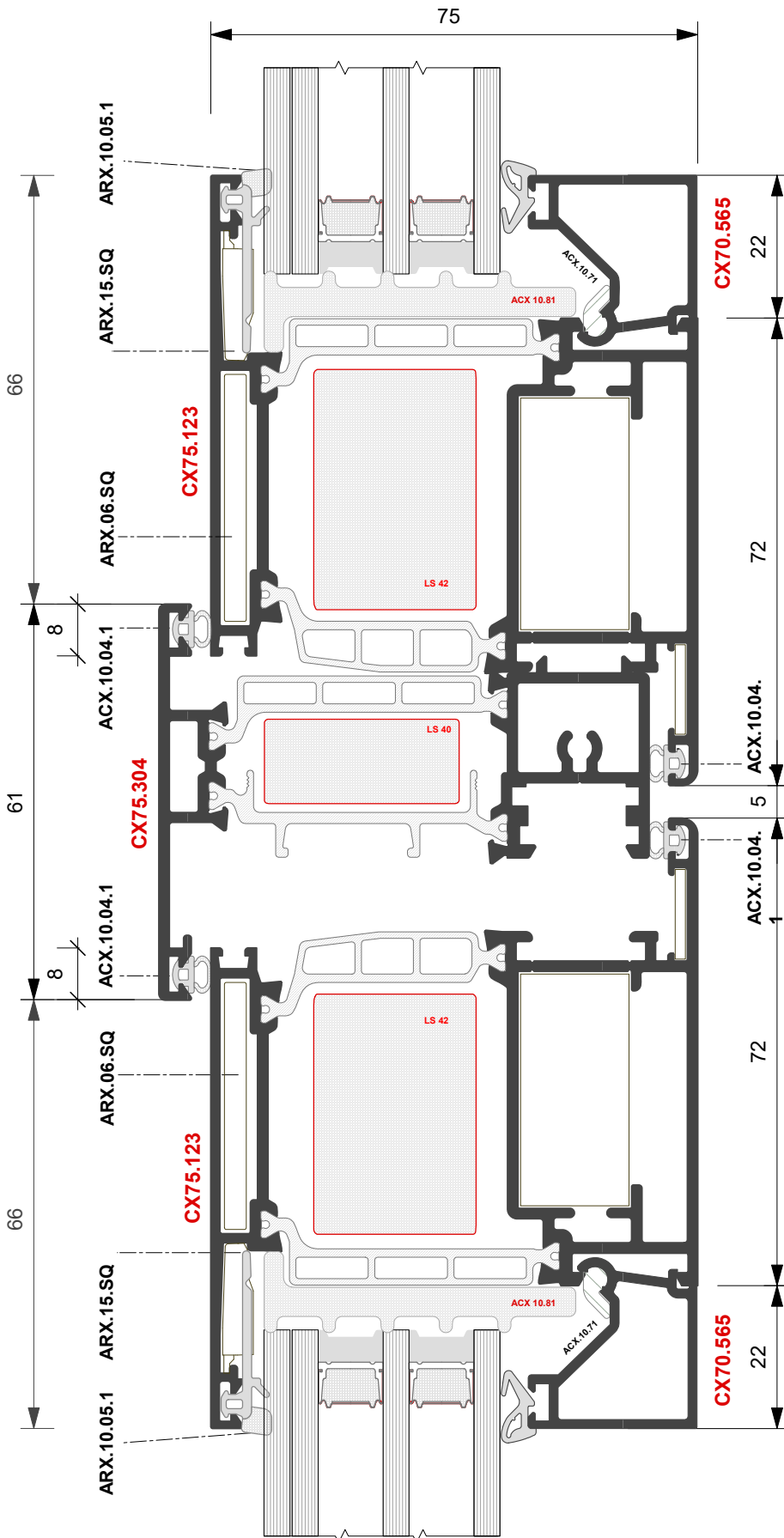

**PORTA INGRESSO A DUE ANTE**  
**Apertura interna**  
*DOUBLE SASH ENTRANCE DOOR*  
*Internal Opening*



**FINESTRA MONOBLOCCO**  
MONOBLOC WINDOW

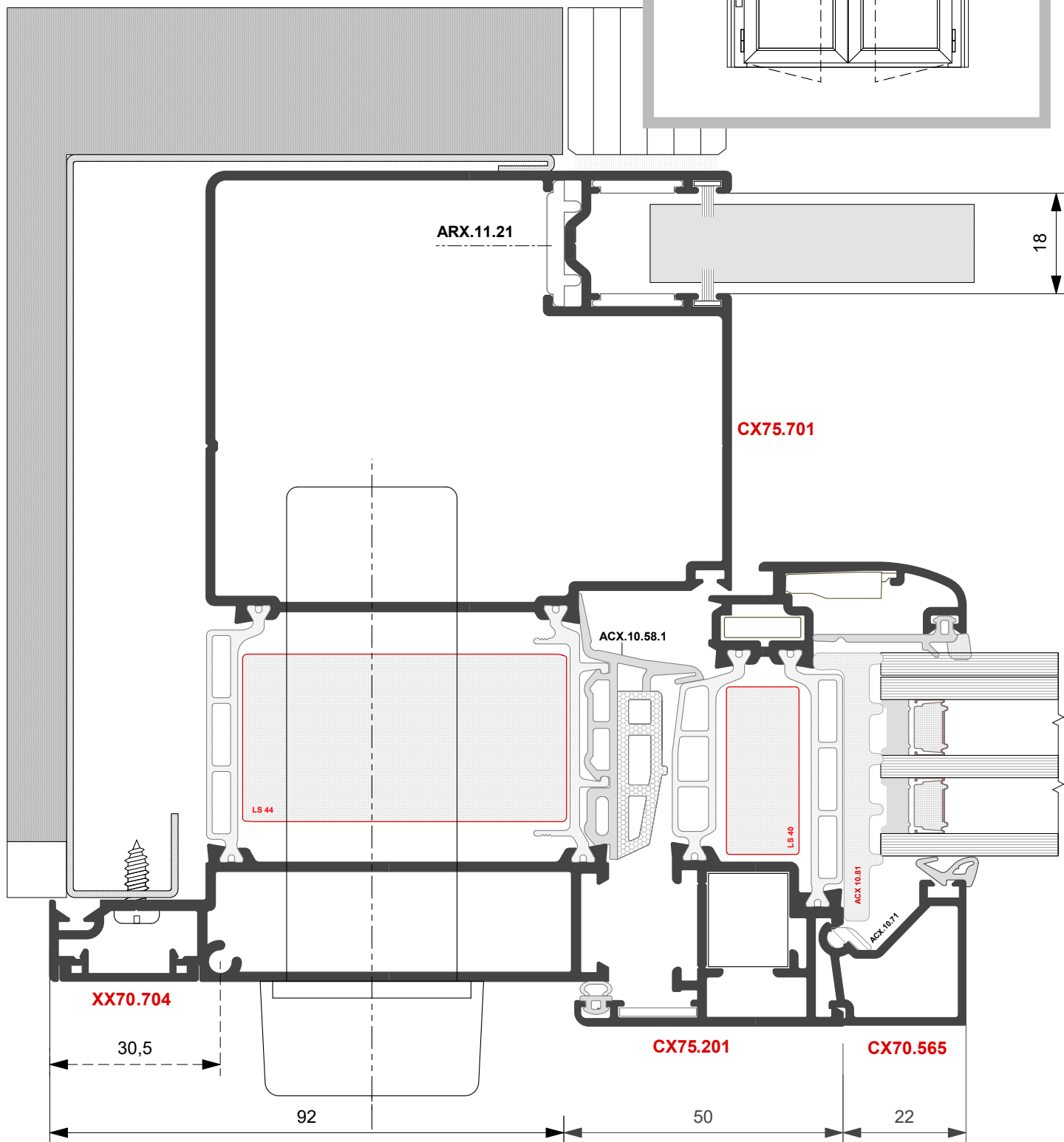
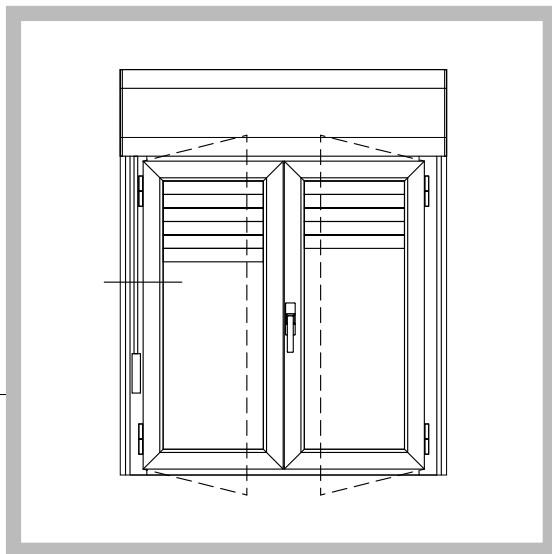



**FINESTRA MONOBLOCCO**  
MONOBLOC WINDOW

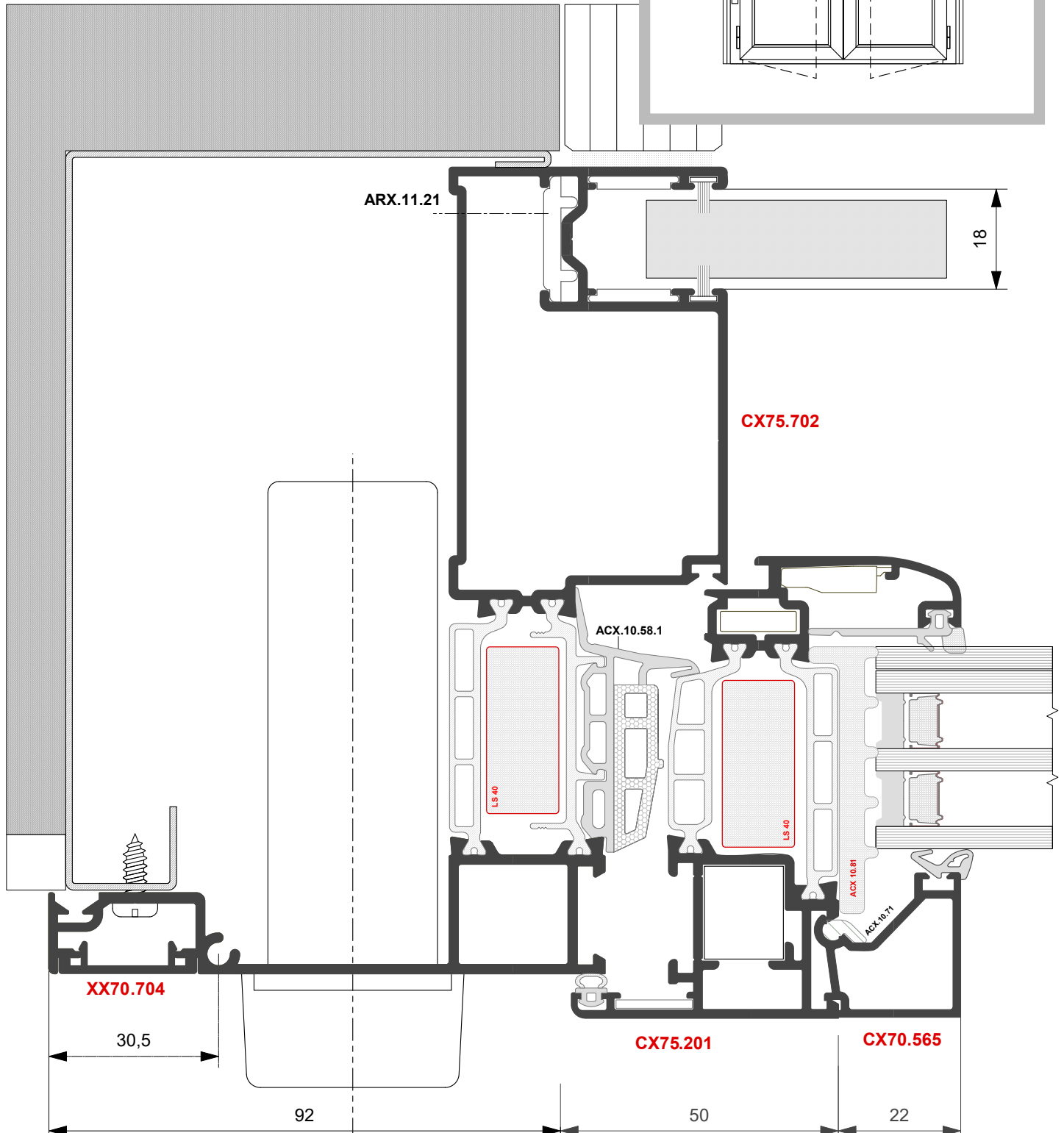
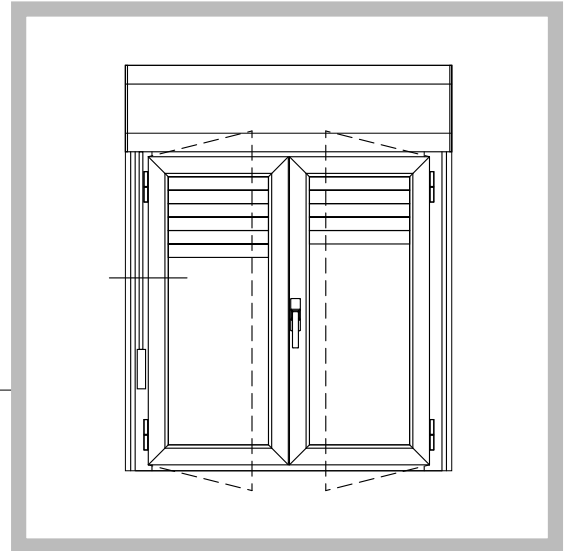



**FINESTRA MONOBLOCCO**  
*MONOBLOC WINDOW*

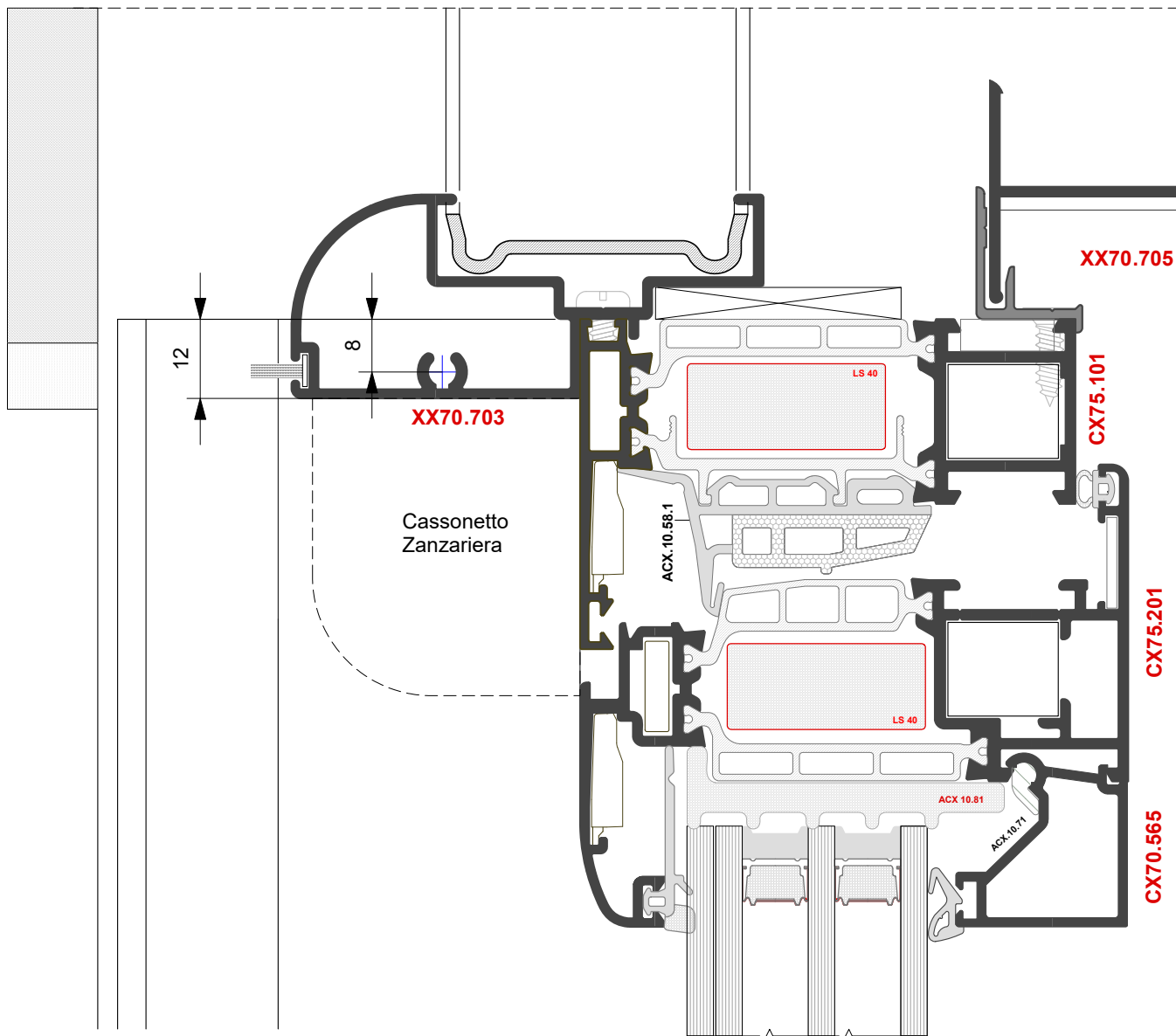
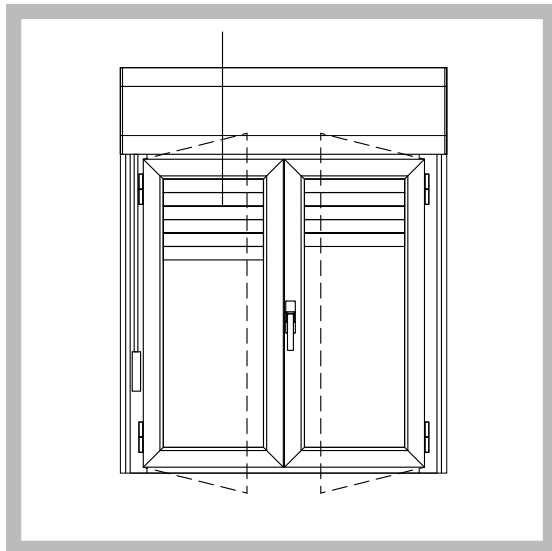



**FINESTRA MONOBLOCCO**  
MONOBLOC WINDOW

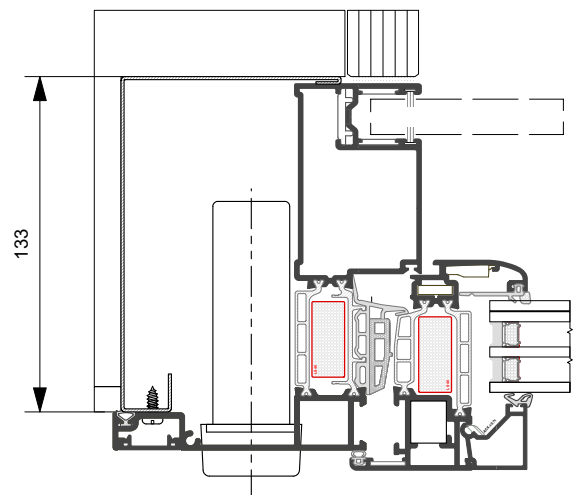
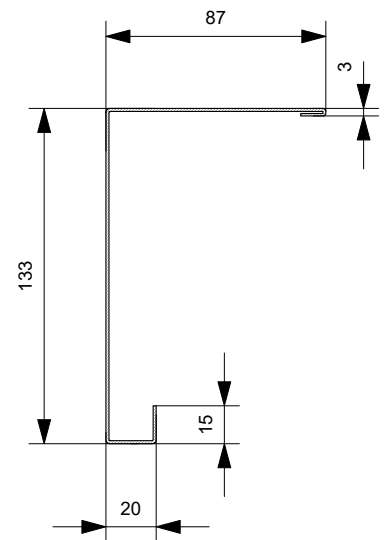
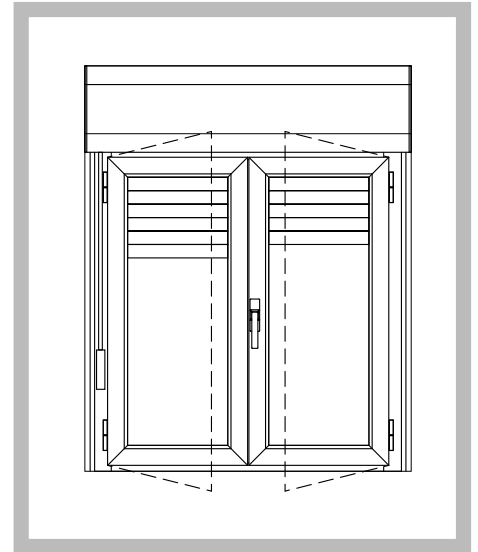
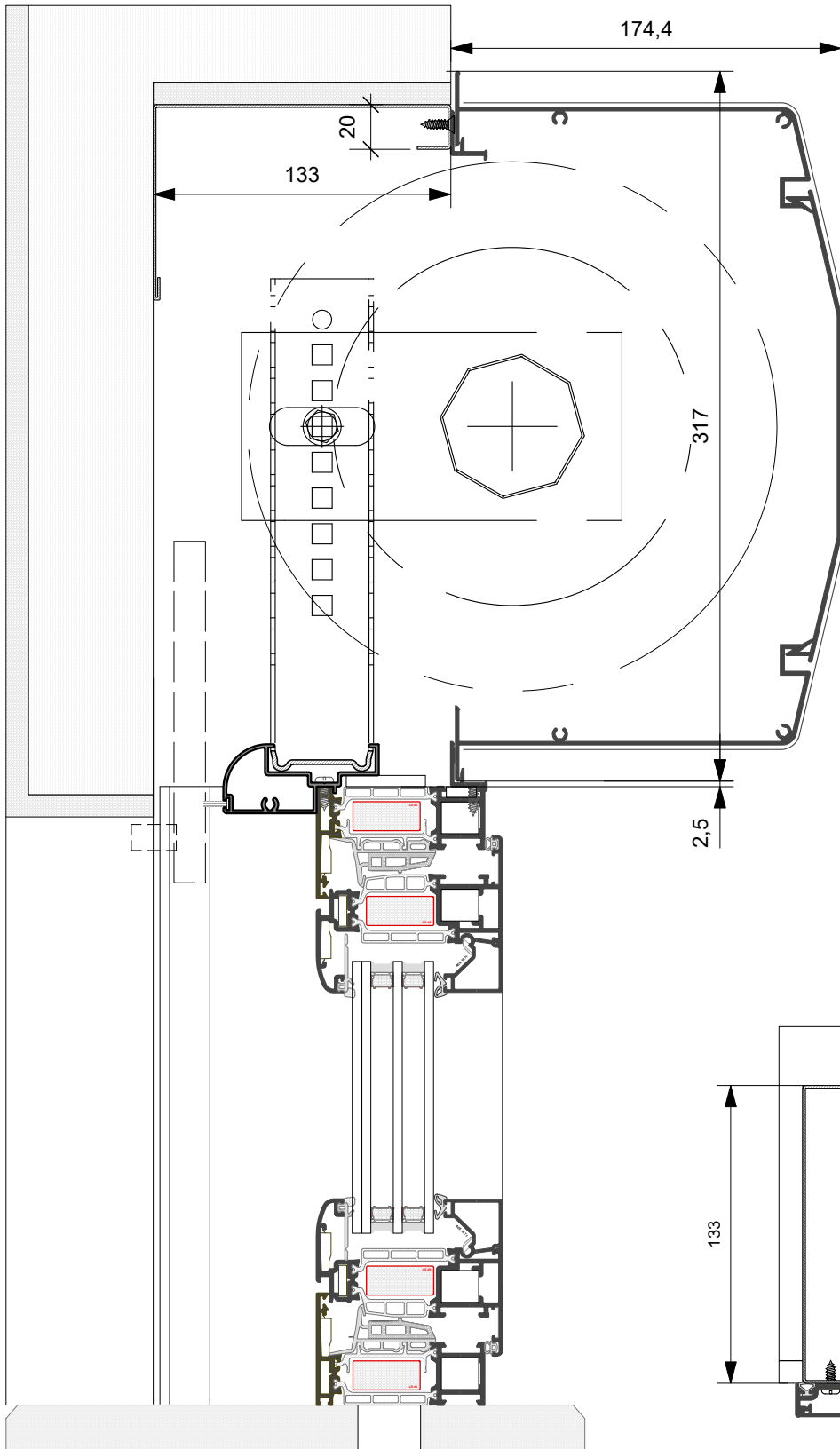



**FINESTRA A DUE ANTE**  
con scuretto  
**DOUBLE SASH WINDOW**  
w/Shutter

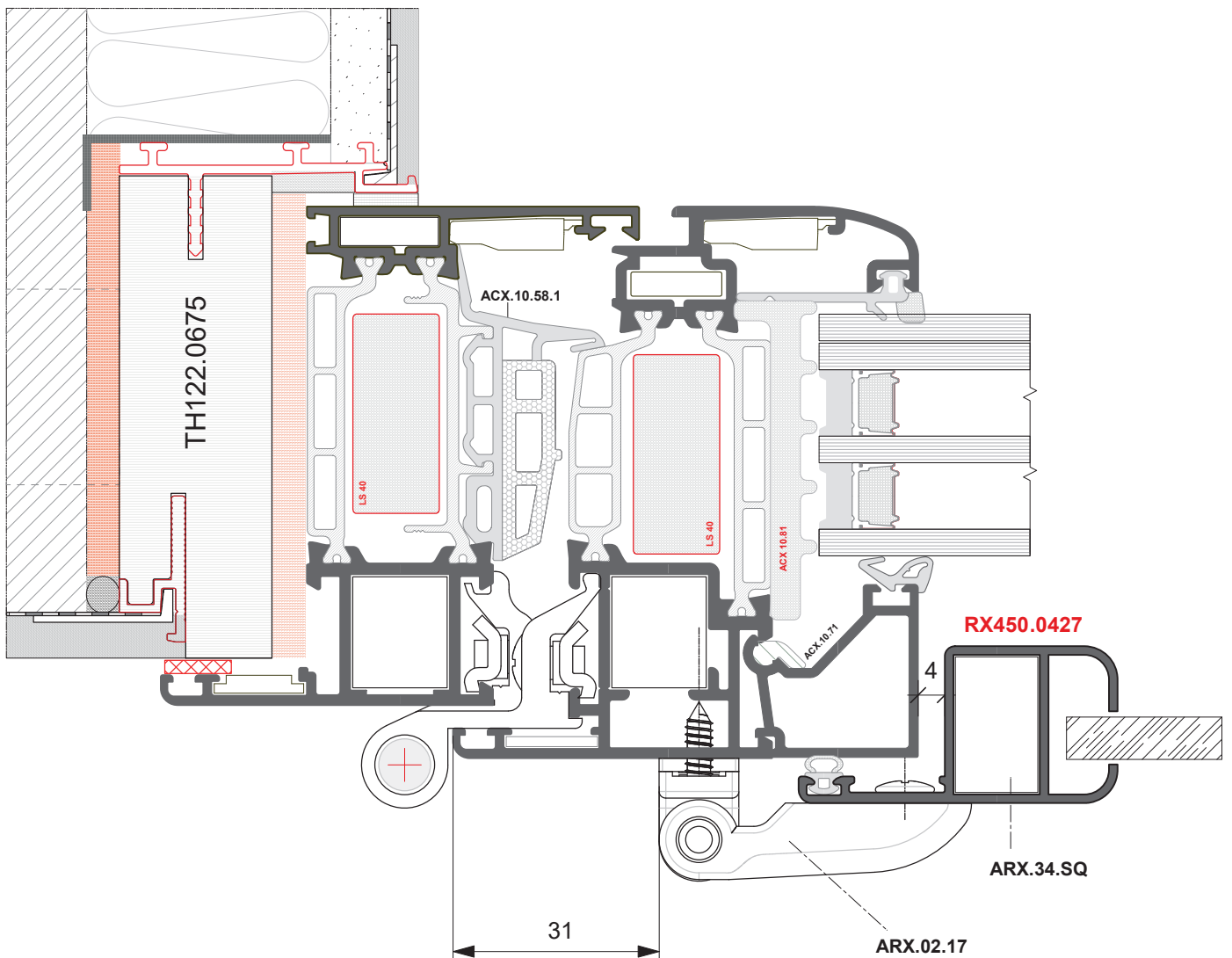
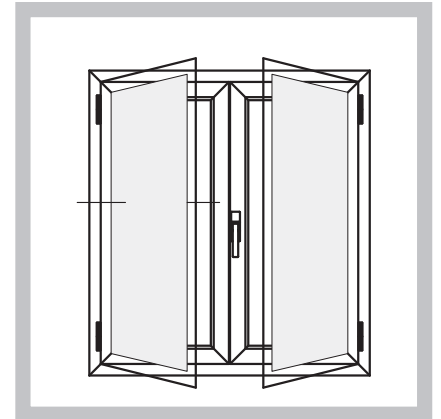



**FINESTRA A DUE ANTE**  
Apertura esterna

**DOUBLE SASH WINDOW**  
External Opening

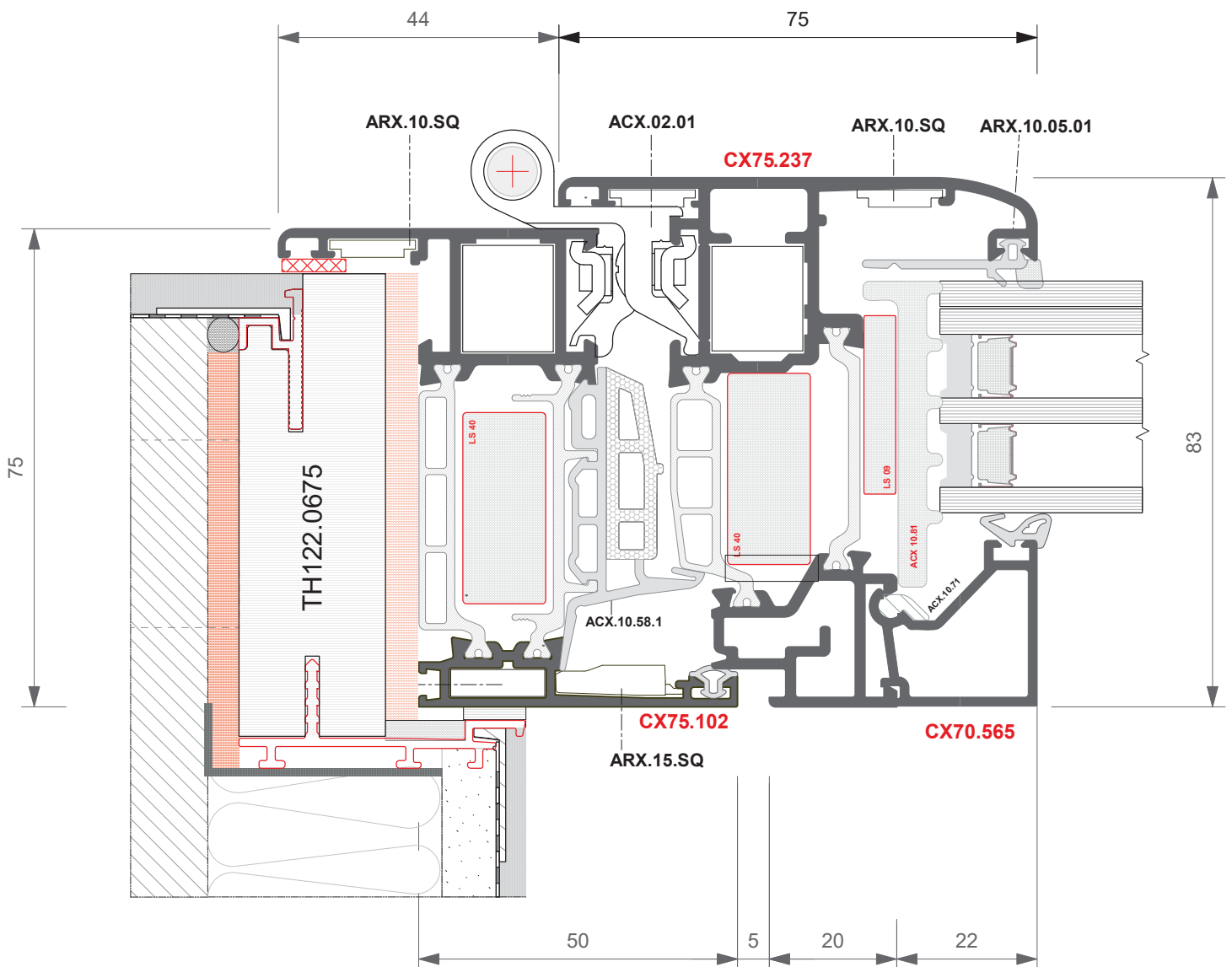
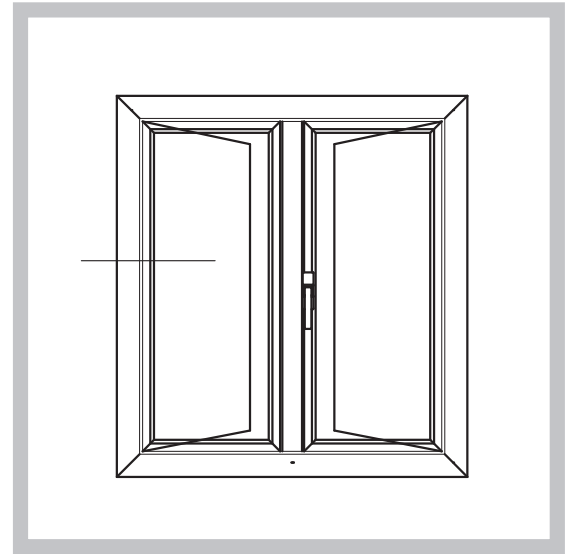



**FINESTRA A DUE ANTE**  
**Apertura esterna**  
**DOUBLE SASH WINDOW**  
**External Opening**

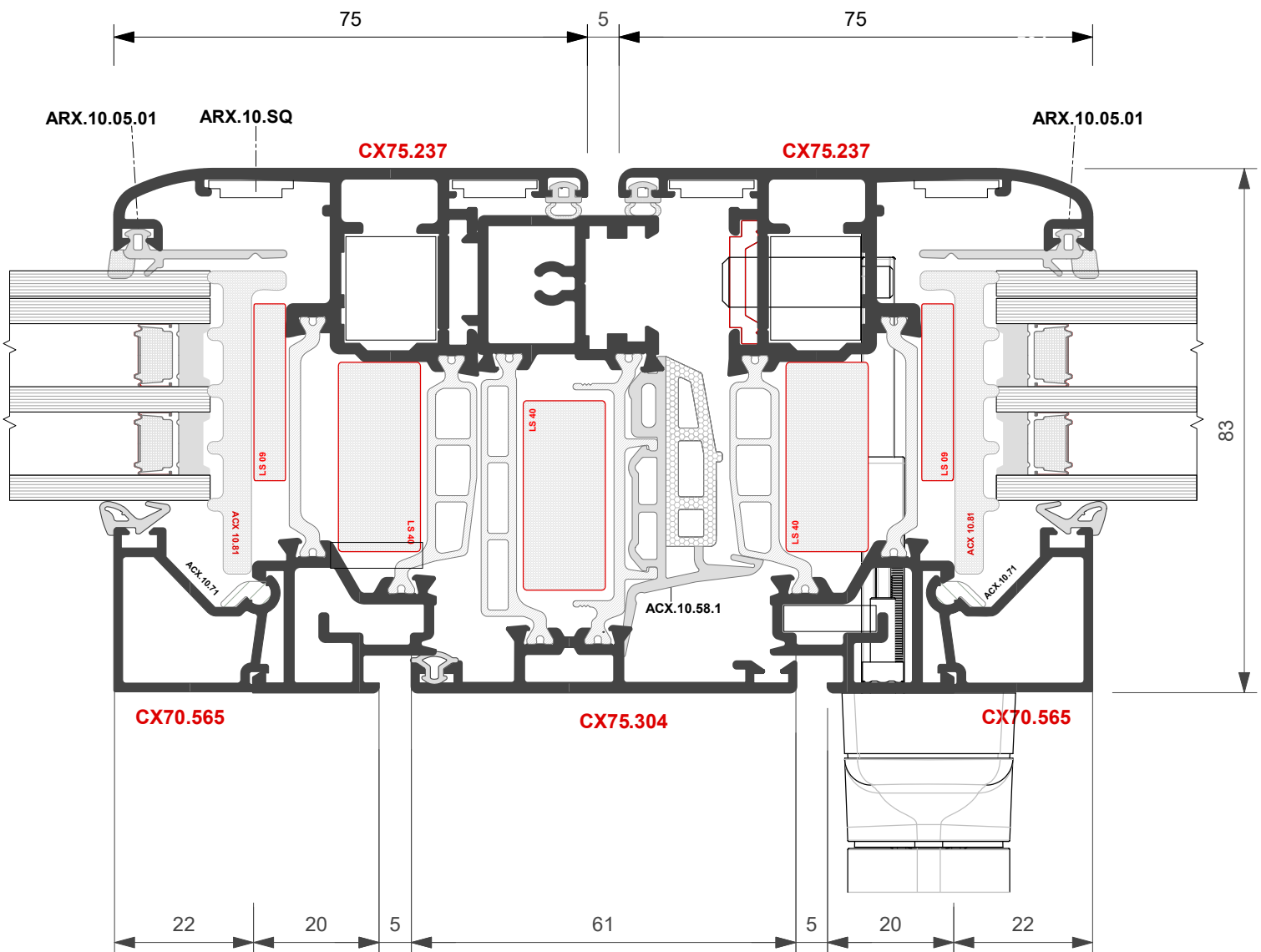
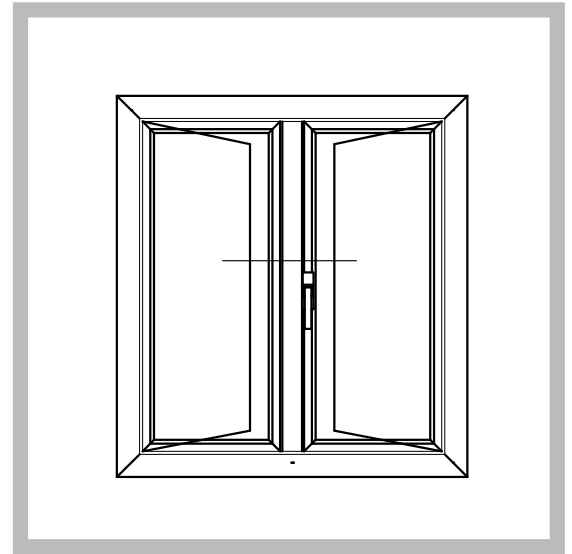



**PORTA A 2 ANTE**  
**PROFILO DOGA XX70.636**  
*DOUBLE SASH DOOR*  
*STAVE PROFILE XX70.636*

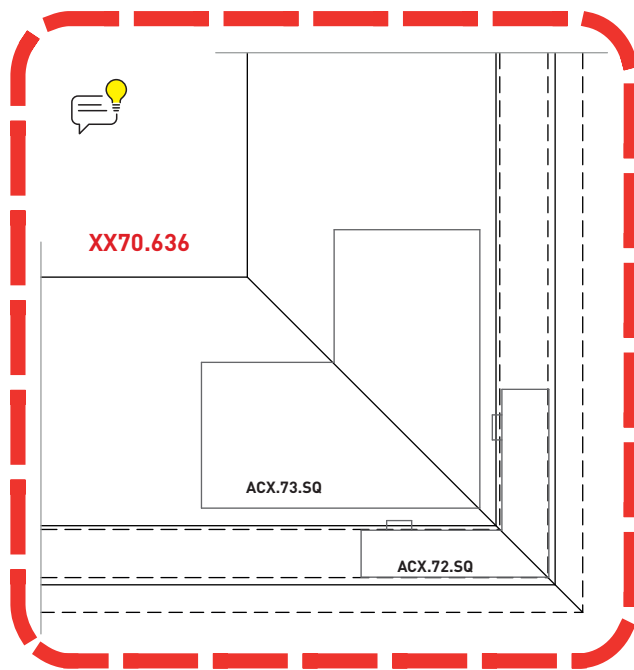
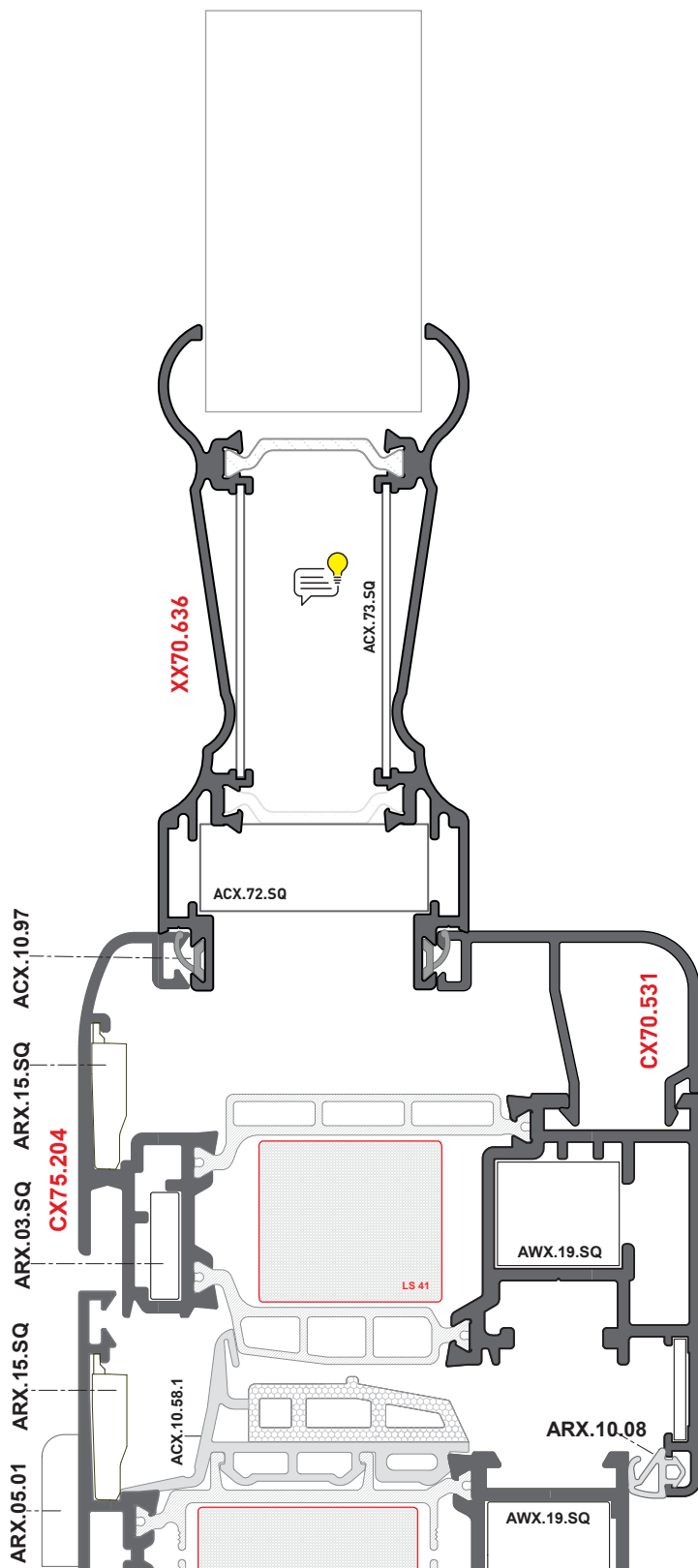
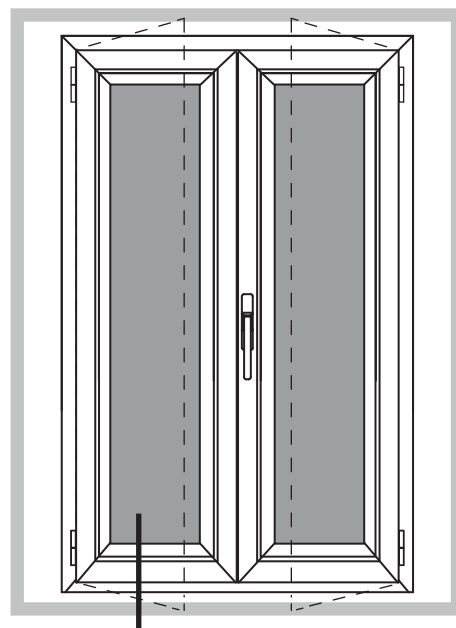





Tipologie  
*Types*

Gruppo **E**

Tipologie  *Main Sections*



**Finestra 1 Anta**  
**1 Sash Window**

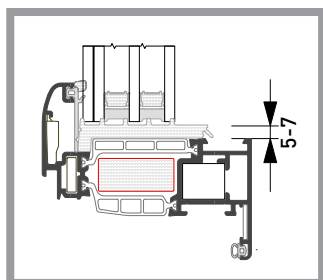
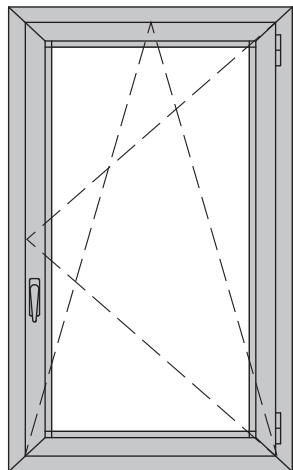

Accessori & Guarnizioni | Accessories & Gaskets

Art.   Code	Descrizione   Description	Qt.
<b>AWX.19.SQ</b>	Squadretta Telaio /Anta   Frame/door corner connection	8
<b>ARX.03.SQ</b>	Squad. Cianfrinare EXT.   External riveting corner joint	8
<b>ARX.10.SQ</b>	Squad. Allin. Anta INT.   Internal door aligning corner joint	4
<b>ARX.15.SQ</b>	Squad. Allin. Telaio/Anta   Frame/door aligning corner joint	8
<b>ACX.02.01</b>	Cerniera 2 Ali   2-leafed hinge	2
<b>ARX.03.06</b>	Cremonese Pressofusa   Die-cast Cremonese bolt	1
<b>ACX.03.14</b>	Ferrogliera   Striker plate	2
<b>ACX.03.17</b>	Innesti Cremonese   Cremonese bolt connections	1
<b>ACX.03.18</b>	Terminale Astina   Bbar Terminal	2
<b>ARX.05.01</b>	Copriasola Scarico Acqua   Water drainage slot cover	2
<b>ARX.06.01</b>	Espansore   Expander	*
<b>ACX.07.02</b>	Angolo Pressofuso Fermavetro   Die-cast glazing bead corner	4
<b>ACX.10.04.1</b>	Guarnizione Battuta   Rabbet window gasket	2H-2L
<b>ARX.10.05.1</b>	Guarnizione Vetro EXT   External glass window gasket	2H-2L
<b>*ARX.10.XX</b>	Guarnizione Vetro INT   Internal glass window gasket	2H-2L
<b>ACX.10.58</b>	Guarnizione Precamera   Prechamber Gasket	2L, 2H
<b>ACX.10.59</b>	Angolo Guarnizione Precamera   Pre-chamber corner connection window gasket	4
<b>ACX.10.81</b>	Isolante Sottovetro   Under glass insulation	2H-2L

\* Secondo Dimensioni | Depending on size

DISTINTA Taglio Vetri		
Qt.	H	L
<b>1</b>	<b>H-150</b>	<b>L-150</b>
Spazio/Gap 5 mm.		

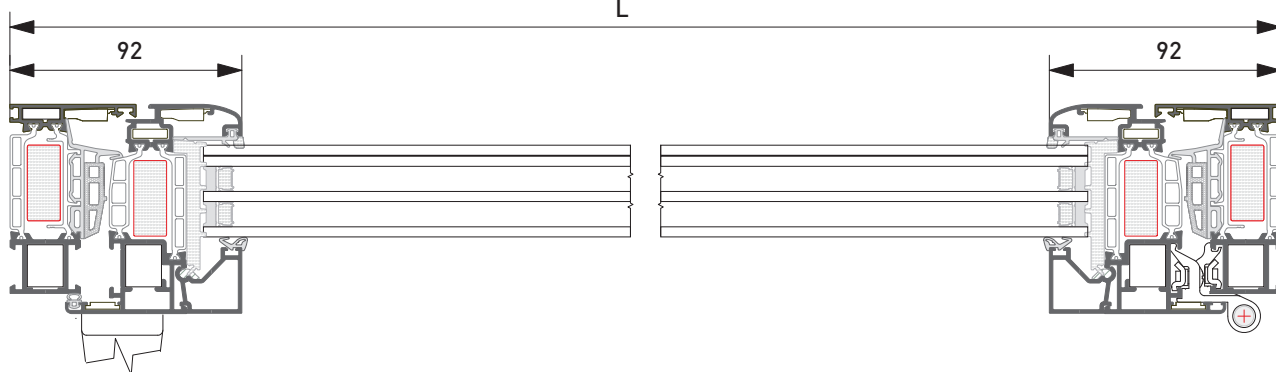
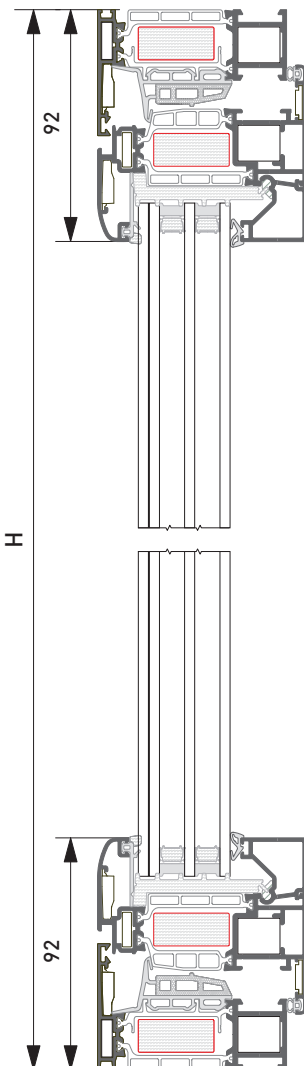

Profilo Profile	Taglio CUT	Qt.	Profilo Profile	Taglio CUT	Qt.	Profilo Profile	Taglio CUT	Qt.
CX75.101 	L	2	CX70.565 	L - 184	2			
	H	2		H - 184	2			
CX75.201 	L - 44	1	CX70.605 					
	H - 44							



**Finestra 2 Ante**  
**2 Sashes Window**

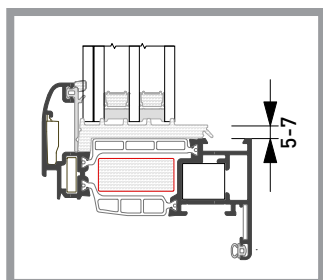
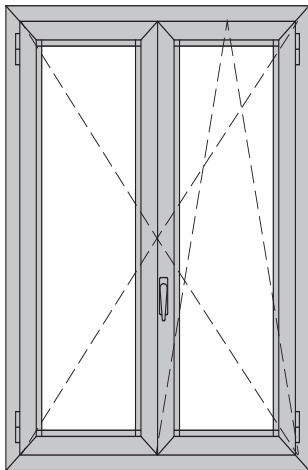

Art.   Code	Descrizione   Description	Qt.
<b>AWX.19.SQ</b>	Squadretta Telaio /Anta   Frame/door corner connection	12
<b>ARX.03.SQ</b>	Squad. Cianfrinare EXT.   External riveting corner joint	12
<b>ARX.10.SQ</b>	Squad. Allin. Anta INT.   Internal door aligning corner joint	8
<b>ARX.15.SQ</b>	Squad. Allin. Telaio/Anta   Frame/door aligning corner joint	12
<b>ACX.02.01</b>	Cerniera 2 Ali   2-leafed hinge	4
<b>ARX.03.06</b>	Cremonese Pressofusa   Die-cast Cremonese bolt	1
<b>ACX.03.14</b>	Ferrogliera   Striker plate	2
<b>ACX.03.17</b>	Innesti Cremonese   Cremonese bolt connections	1
<b>ACX.03.18</b>	Terminale Astina   Bbar Terminal	2
<b>ACX.03.71</b>	Paletto mini TEX   mini TEX lever bolt	2
<b>ACX.04.54</b>	Tappo Riparto Centrale   Central wing cap	1
<b>ARX.05.01</b>	Copriasola Scarico Acqua   Water drainage slot cover	2
<b>ARX.06.01</b>	Espansore   Expander	*
<b>ACX.07.02</b>	Angolo Pressofuso Fermavetro   Die-cast glazing bead corner	8
<b>ACX.10.04.1</b>	Guarnizione Battuta   Rabbet window gasket	4H-2L
<b>ARX.10.05.1</b>	Guarnizione Vetro EXT   External glass window gasket	4H-2L
<b>*ARX.10.XX</b>	Guarnizione Vetro INT   Internal glass window gasket	4H-2L
<b>ACX.10.58</b>	Guarnizione Precamera   Prechamber Gasket	3H-2L
<b>ACX.10.59</b>	Angolo Guarnizione Precamera   Pre-chamber corner connection window gasket	4
<b>ACX.10.81</b>	Isolante Sottovetro   Under glass insulation	4H-2L

\* Secondo Dimensioni | Depending on size

DISTINTA Taglio Vetri   Glass Cutting List		
Qt.	H	L
<b>2</b>	<b>H-150</b>	<b>L/2-130.5</b>
Spazio/Gap 5 mm.		

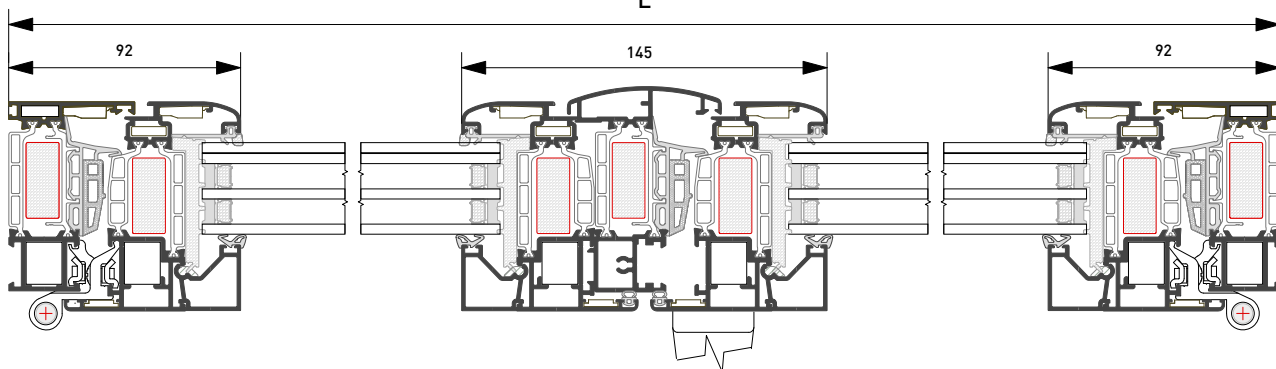
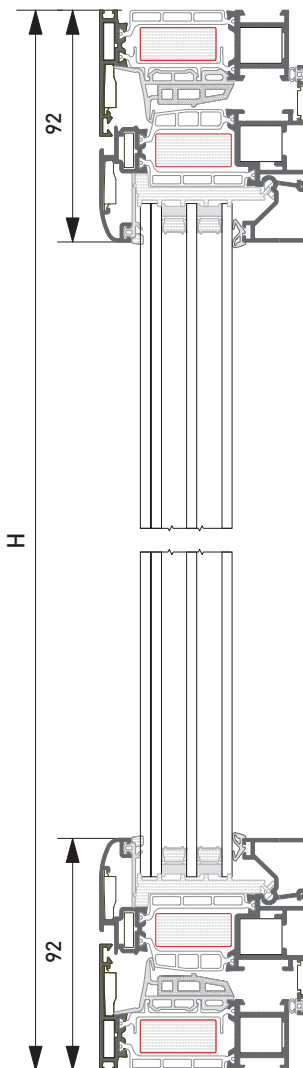

Profilo Profile	Taglio CUT	Qt.	Profilo Profile	Taglio CUT	Qt.	Profilo Profile	Taglio CUT	Qt.
<b>CX75.101</b> 	<b>L</b>	<b>2</b>	<b>CX70.565</b> 	<b>L/2 - 164.5</b>	<b>4</b>	<b>CX70.605</b> 	<b>H</b>	<b>4</b>
	<b>H</b>	<b>2</b>		<b>H - 184</b>	<b>4</b>			
<b>CX75.201</b> 	<b>L/2 - 24.5</b>	<b>4</b>	<b>CX75.301</b> 	<b>H - 110</b>	<b>1</b>			
	<b>H - 44</b>	<b>4</b>						



**Porta 1 Anta**  
**1 Sash Door**

Accessori & Guarnizioni | Accessories & Gaskets

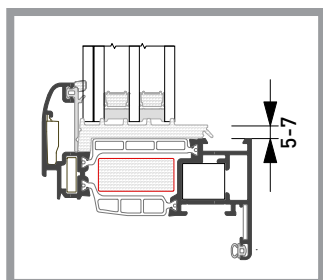
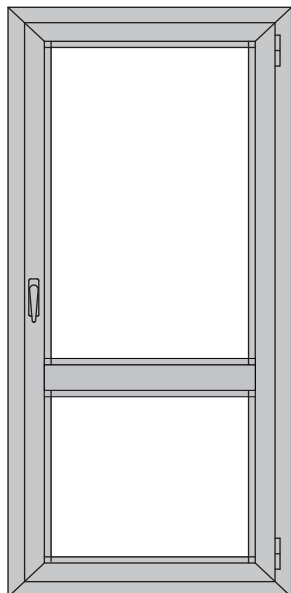

Art.   Code	Descrizione   Description	Qt.
<b>AWX.19.SQ</b>	Squadretta Telaio /Anta   Frame/door corner connection	8
<b>ARX.03.SQ</b>	Squad. Cianfrinare EXT.   External riveting corner joint	8
<b>ARX.10.SQ</b>	Squad. Allin. Anta INT.   Internal door aligning corner joint	4
<b>ARX.15.SQ</b>	Squad. Allin. Telaio/Anta   Frame/door aligning corner joint	8
<b>ACX.02.01</b>	Cerniera 2 Ali   2-leafed hinge	3
<b>ARX.03.06</b>	Cremonese Pressofusa   Die-cast Cremonese bolt	1
<b>ACX.03.14</b>	Ferrogliera   Striker plate	2
<b>ACX.03.17</b>	Innesti Cremonese   Cremonese bolt connections	1
<b>ACX.03.18</b>	Terminale Astina   Bbar Terminal	2
<b>ARX.05.01</b>	Copriasola Scarico Acqua   Water drainage slot cover	2
<b>ARX.06.01</b>	Espansore   Expander	*
<b>ACX.07.02</b>	Angolo Pressofuso Fermavetro   Die-cast glazing bead corner	8
<b>ACX.10.04.1</b>	Guarnizione Battuta   Rabbet window gasket	2H-2L
<b>ARX.10.05.1</b>	Guarnizione Vetro EXT   External glass window gasket	2H-4L
<b>*ARX.10.XX</b>	Guarnizione Vetro INT   Internal glass window gasket	2H-4L
<b>ACX.10.58</b>	Guarnizione Precamera   Prechamber Gasket	2H-2L
<b>ACX.10.59</b>	Angolo Guarnizione Precamera   Pre-chamber corner connection window gasket	4
<b>ACX.10.81</b>	Isolante Sottovetro   Under glass insulation	2H-4L

\* Secondo Dimensioni | Depending on size

DISTINTA Taglio Vetri   Glass Cutting List		
Qt.	H	L
<b>1</b>	<b>H - H<sub>fa</sub> - 58</b>	<b>L - 150</b>
<b>1</b>	<b>H<sub>fa</sub> - 154</b>	<b>L - 150</b>

Spazio/Gap 5 mm.

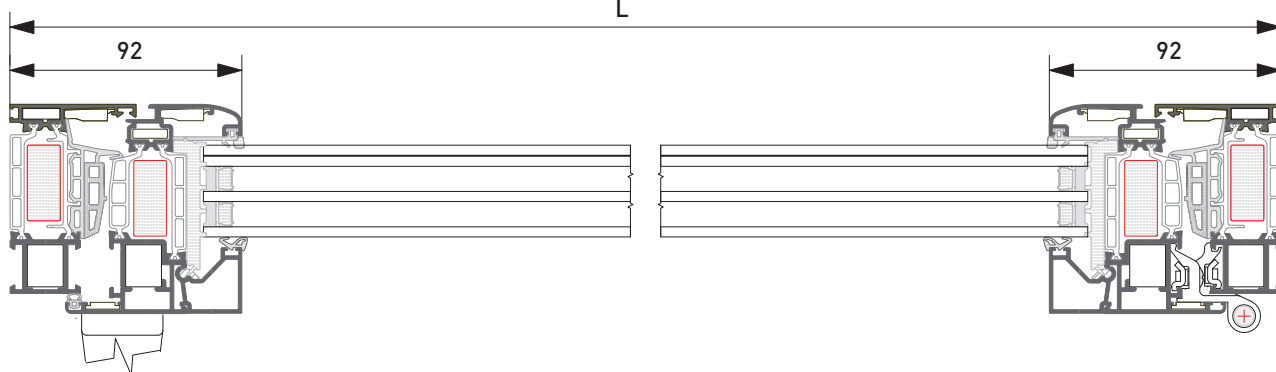
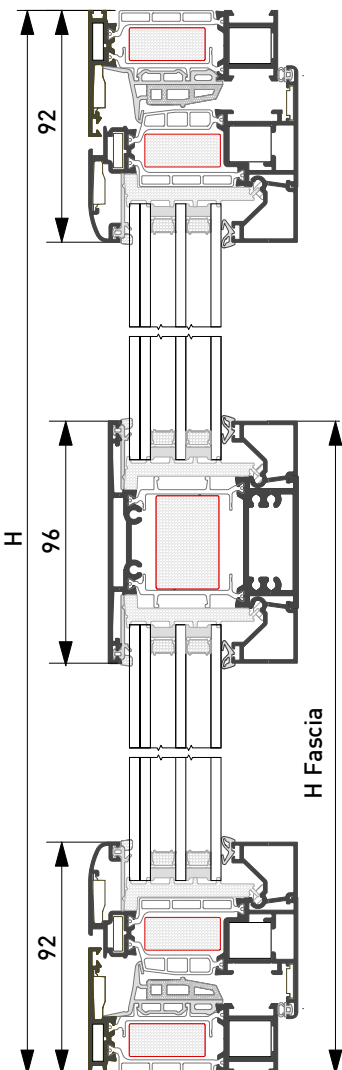

Profilo Profile	Taglio CUT	Qt.	Profilo Profile	Taglio CUT	Qt.	Profilo Profile	Taglio CUT	Qt.
CX75.101	L	2	CX70.565	L - 184	4	CX75.402	L - 130	1
	H	2		H - H <sub>fa</sub> - 92	2			
CX75.201	L - 44	2		H <sub>fa</sub> - 188	2			
	H - 44	2	CX70.605					



**Porta 2 Ante**  
**2 Sashes Door**

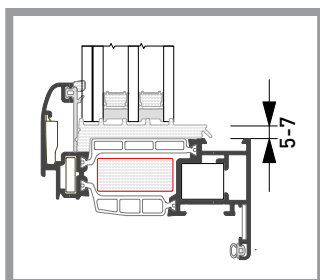
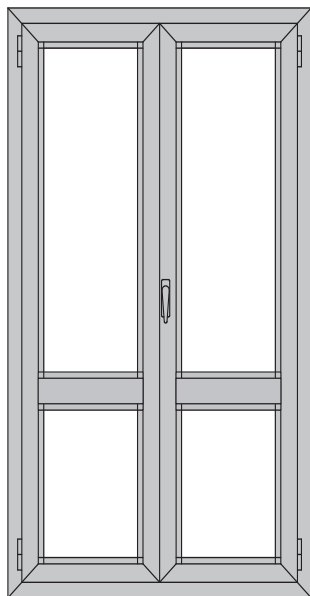

Art.   Code	Descrizione   Description	Qt.
<b>AWX.19.SQ</b>	Squadretta Telaio /Anta   Frame/door corner connection	12
<b>ARX.03.SQ</b>	Squad. Cianfrinare EXT.   External riveting corner joint	12
<b>ARX.10.SQ</b>	Squad. Allin. Anta INT.   Internal door aligning corner joint	8
<b>ARX.15.SQ</b>	Squad. Allin. Telaio/Anta   Frame/door aligning corner joint	12
<b>ACX.02.01</b>	Cerniera 2 Ali   2-leafed hinge	6
<b>ARX.03.06</b>	Cremonese Pressofusa   Die-cast Cremonese bolt	1
<b>ACX.03.14</b>	Ferrogliera   Striker plate	2
<b>ACX.03.17</b>	Innesti Cremonese   Cremonese bolt connections	1
<b>ACX.03.18</b>	Terminale Astina   Bbar Terminal	2
<b>ACX.03.71</b>	Paletto mini TEX   mini TEX lever bolt	2
<b>ACX.04.54</b>	Tappo Riporto Centrale   Central wing cap	1
<b>ARX.05.01</b>	Copriasola Scarico Acqua   Water drainage slot cover	2
<b>ARX.06.01</b>	Espansore   Expander	*
<b>ACX.07.02</b>	Angolo Pressofuso Fermavetro   Die-cast glazing bead corner	16
<b>ACX.10.04.1</b>	Guarnizione Battuta   Rabbet window gasket	4H-2L
<b>ARX.10.05.1</b>	Guarnizione Vetro EXT   External glass window gasket	4H-4L
<b>*ARX.10.XX</b>	Guarnizione Vetro INT   Internal glass window gasket	4H-4L
<b>ACX.10.58</b>	Guarnizione Precamera   Prechamber Gasket	3H-2L
<b>ACX.10.59</b>	Angolo Guarnizione Precamera   Pre-chamber corner connection window gasket	4
<b>ACX.10.81</b>	Isolante Sottovetro   Under glass insulation	4H-4L

\* Secondo Dimensioni | Depending on size

<b>DISTINTA Taglio Vetri   Glass Cutting List</b>		
Qt.	H	L
<b>1</b>	<b>H - H<sub>Fa</sub> - 58</b>	<b>L/2 - 130.5</b>
<b>2</b>	<b>H<sub>Fa</sub> - 154</b>	<b>L/2 - 130.5</b>

Spazio/Gap 5 mm.

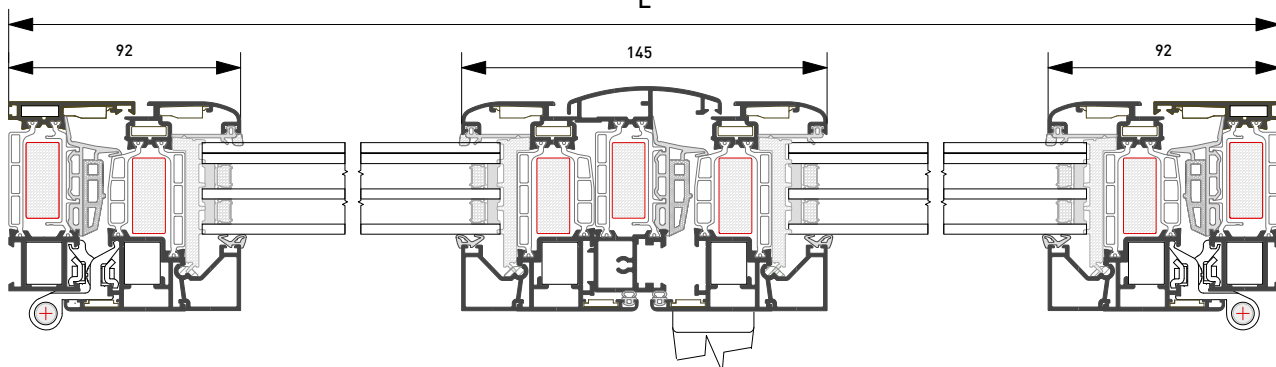
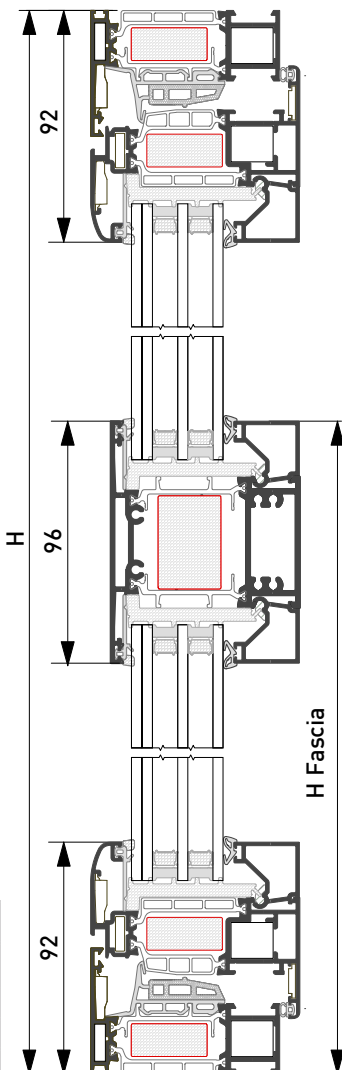

Profilo Profile	Taglio CUT	Qt.	Profilo Profile	Taglio CUT	Qt.	Profilo Profile	Taglio CUT	Qt.
CX75.101	L	2	CX75.565	L/2 - 164.5	8	CX75.301	H - 110	1
	H	2		H - H <sub>Fa</sub> - 92	4			
CX75.201	L/2 - 24.5	4		H <sub>Fa</sub> - 188	4	CX75.402	L/2 - 110	2
	H - 44	2	CX70.605		1			





**Attacco alla Muratura**  
*Connection to Brickwork*

**Gruppo F**

Sezione particolareggiata  
attacco alla muratura

*Wall Joint Detail*

**SCHEMA FISSAGGIO | Fixing**

**Tipo A | Type A**

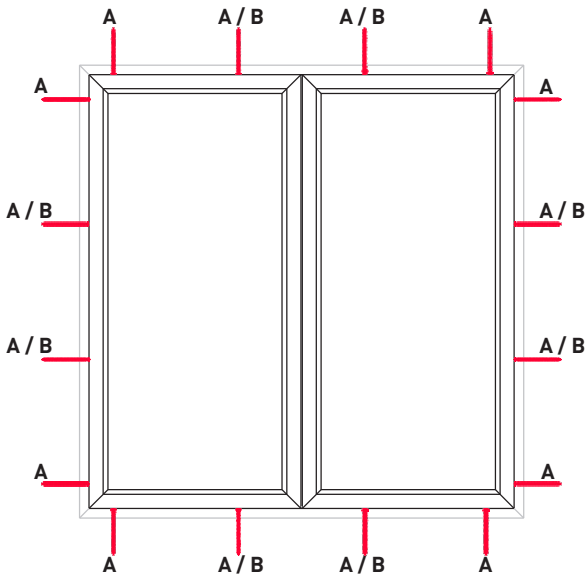

**DAGLI ANGOLI | From the CORNERS = 150 mm.**

**INTERASSE | Center Distance = 700 mm.**

**FISSAGGI MINIMI | Minimum Fasteners = 8 Fasteners**

Verticale = 3 Fissaggi /Lato | Vertical = 3 Fasteners/ Side  
Orizzontale = 1 Fissaggio/Lato | Horizontal = Fasteners/Side

**ARX.06.13** REGISTRO TELAIO TWIN AUTOBLOCCANTE SU BARRETTE

TWIN frame register self-Locking on bars

**PUNTA 2 DIAMETRI**

Tip 2 diameters

**LAMATORE**

LAMATOR

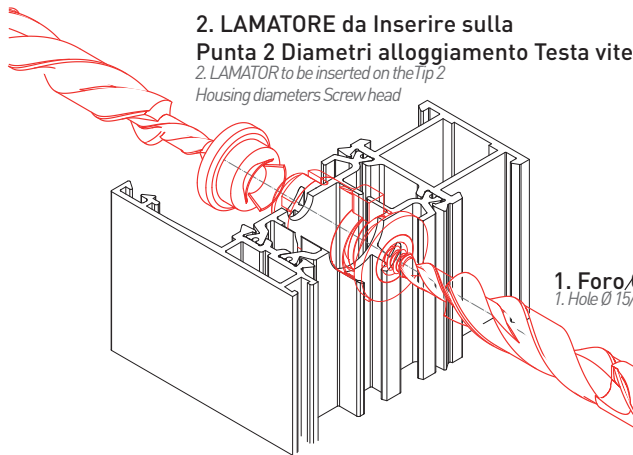
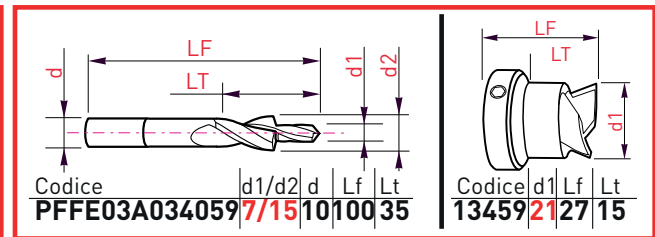
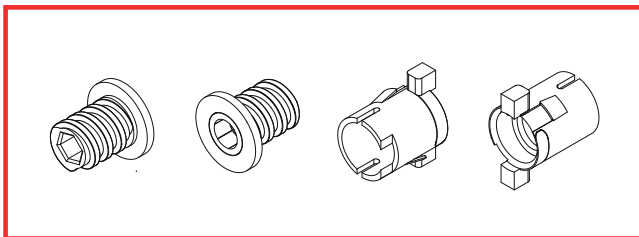

**Vite autofilettante Ø4.8**  
**UNI6954 [DIN7981/ISO7049]** **Tipo B**  
Self-tapping screw Ø4.8

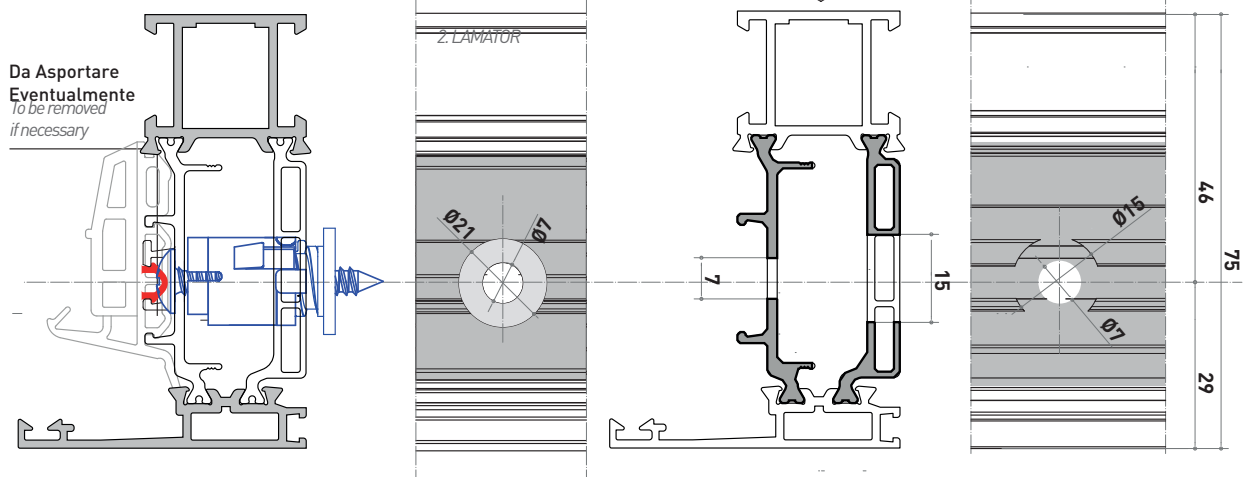
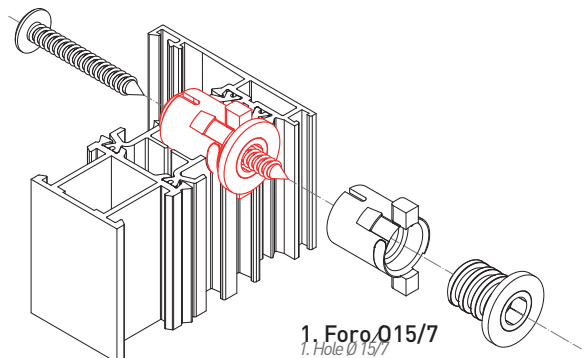



## FISSAGGIO ALLA MURATURA

*Fixing to the wall*

Registro Telaio TWIN SYSTEMS Autobloccante su Barrette  
*Self Locking TWIN SYSTEMS Frame On Bars*

**ARX.06.13**

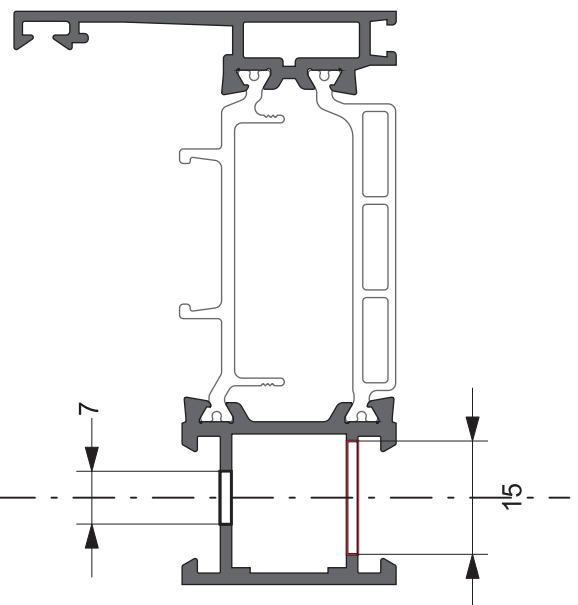
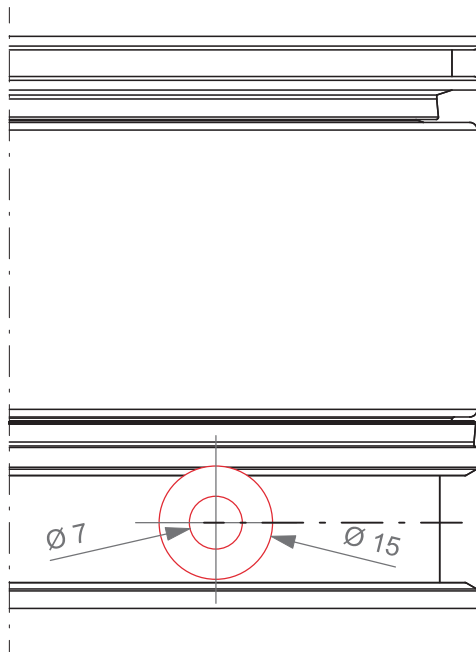
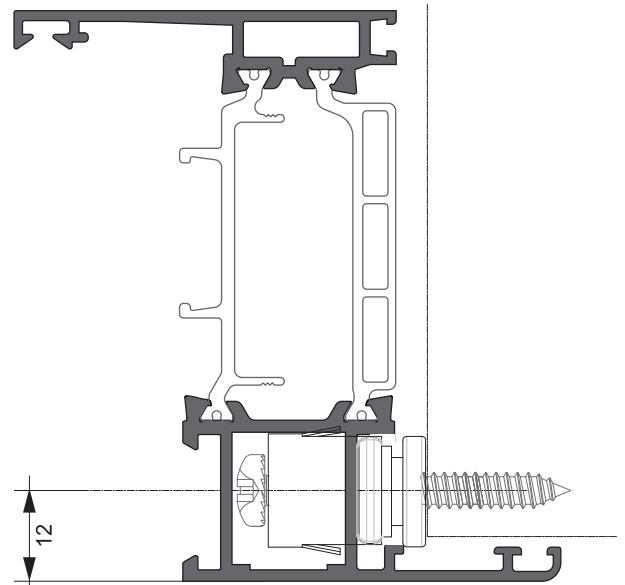
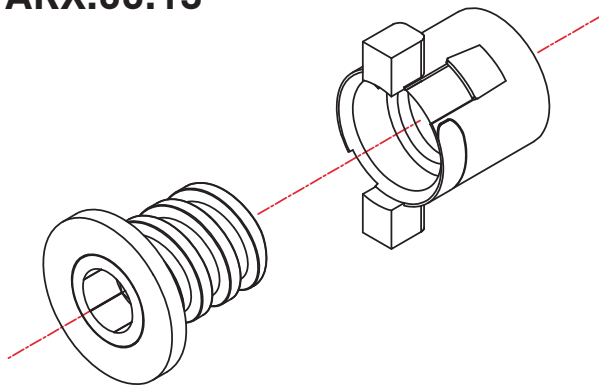







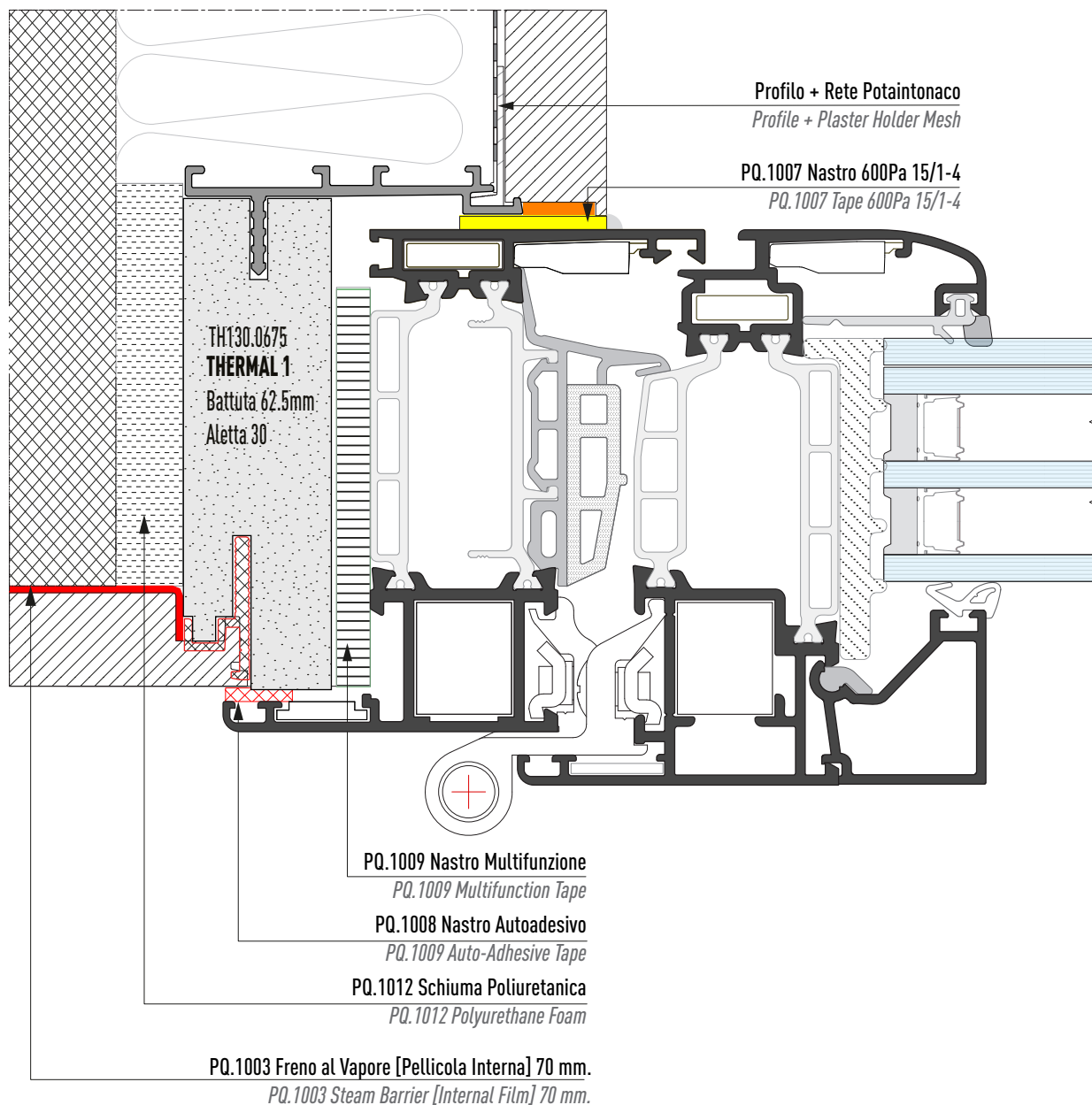



SEZIONE ORIZZONTALE

POSA QUALITÀ

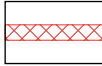

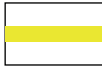
LEGENDA MATERIALI

	<b>Muratura</b> <i>Brickwall</i>		<b>Controtelaio THERMAL</b> <i>Wall frame THERMAL</i>		<b>PQ.1012 Schiuma Poliuretanicca</b> <i>PQ.1012 Polyurethane Foam</i>
	<b>Intonaco</b> <i>Plaster</i>		<b>PQ.1008 Nastro Autoadesivo 9x2</b> <i>PQ.1008 Auto-Adhesive Tape 9x2</i>		<b>PQ.1003 Freno al Vapore [Pellicola Interna] 70 mm.</b> <i>PQ.1003 Steam Barrier [Internal Film] 70 mm.</i>
	<b>Isolamento</b> <i>Insulation</i>		<b>PQ.1007 Nastro 600Pa 15/1-4</b> <i>PQ.1007 Tape 600Pa 15/1-4</i>		<b>Sigillante Ibrido</b> <i>Hybrid Sealant</i>







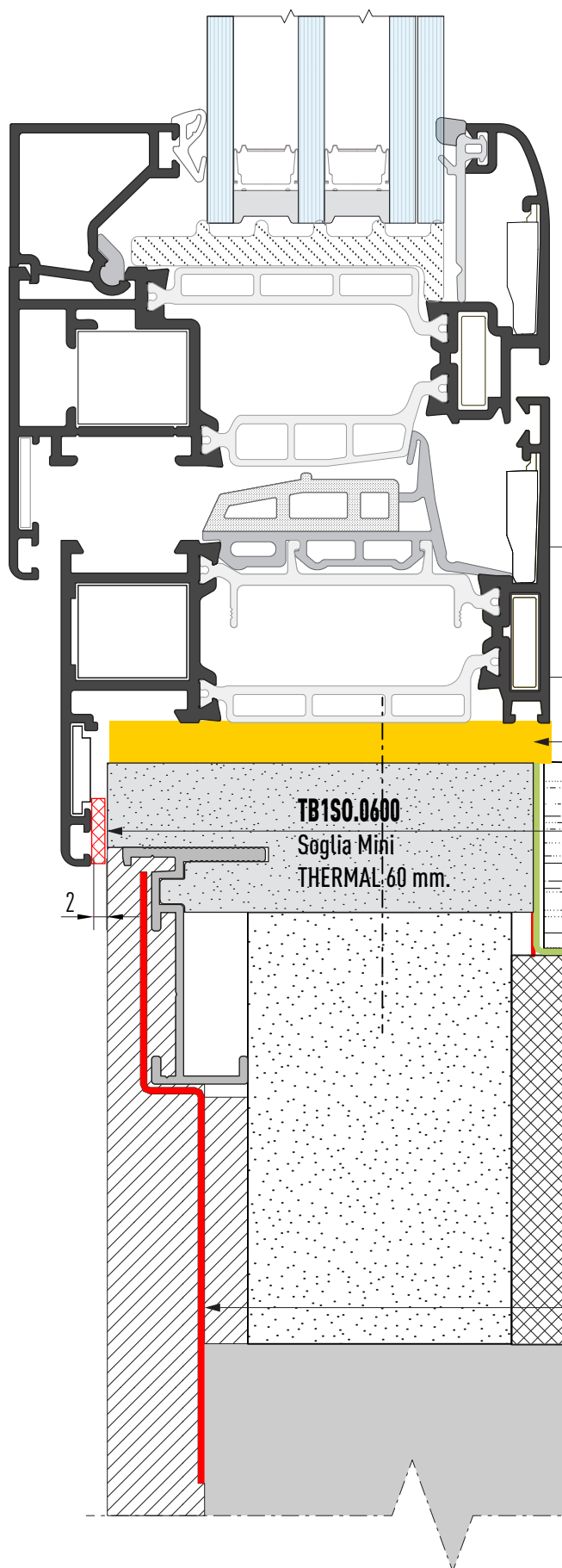

SEZIONE VERTICALE

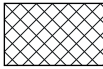
LEGENDA MATERIALI

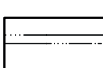
**POSA QUALITÀ**

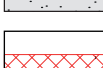
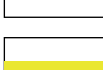

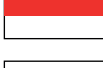
-  **Muratura**  
*Brickwall*
-  **Intonaco**  
*Plaster*
-  **Soglia**  
*Threshold*
-  **Controtelaio THERMAL**  
*Wall frame THERMAL*
-  **PQ.1008 Nastro Autoadesivo 9x2**  
*PQ.1008 Auto-Adhesive Tape 9x2*
-  **PQ.1007 Nastro 600Pa 15/1-4**  
*PQ.1007 Tape 600Pa 15/1-4*
-  **PQ.1012 Schiuma Poliuretanic**  
*PQ.1012 Polyurethane Foam*
-  **PQ.1003 Freno al Vapore [Pellicola Interna] 70 mm.**  
*PQ.1003 Steam Barrier [Internal Film] 70 mm.*
-  **PQ.1005 Guaina Esterna EPDM 80 mm.**  
*PQ.1005 External Sheath EPDM 80 mm.*

PQ.1010 Nastro PE 60x6 mm.  
*PQ.1010 Tape PE 60x6 mm.*

PQ.1008 Nastro PE 9x2 mm.  
*PQ.1008 Tape PE 9x2 mm.*

PQ.1005 Guaina Esterna EPDM 80 mm.  
*PQ.1005 External Sheath EPDM 80 mm.*

PQ.1003 Pellicola Interna 70 mm.  
*PQ.1003 Internal Film 70 mm.*

**TB150.0600**  
**Soglia Mini**  
**THERMAL 60 mm.**

2



► **CONTROTELAIO PERIMETRALE**  
**PERIMETRAL COUNTERFRAME**

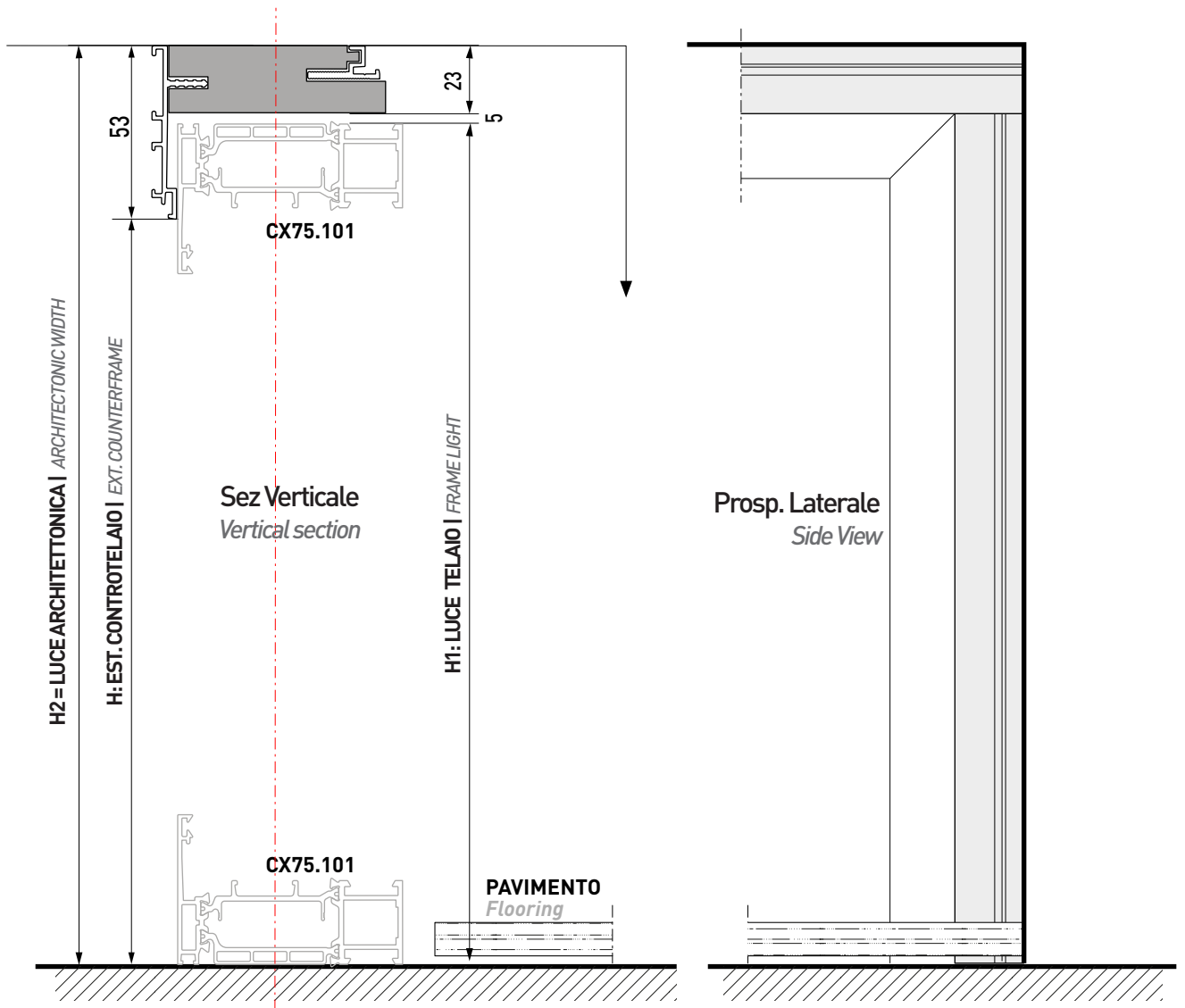
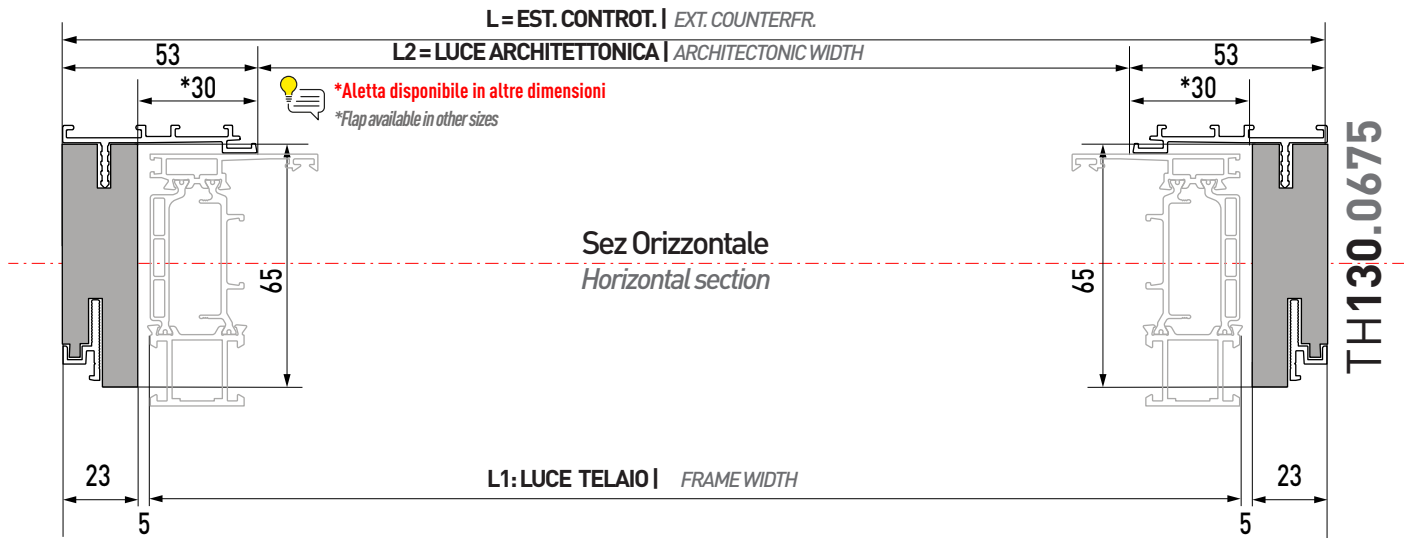



Lavorazioni e Montaggi  
*Tooling and Assembly*

Gruppo **G**

Schemi Lavorazioni  
Frese  
Attrezzatura

*Tooling Systems  
Cutters Equipments  
Milling*

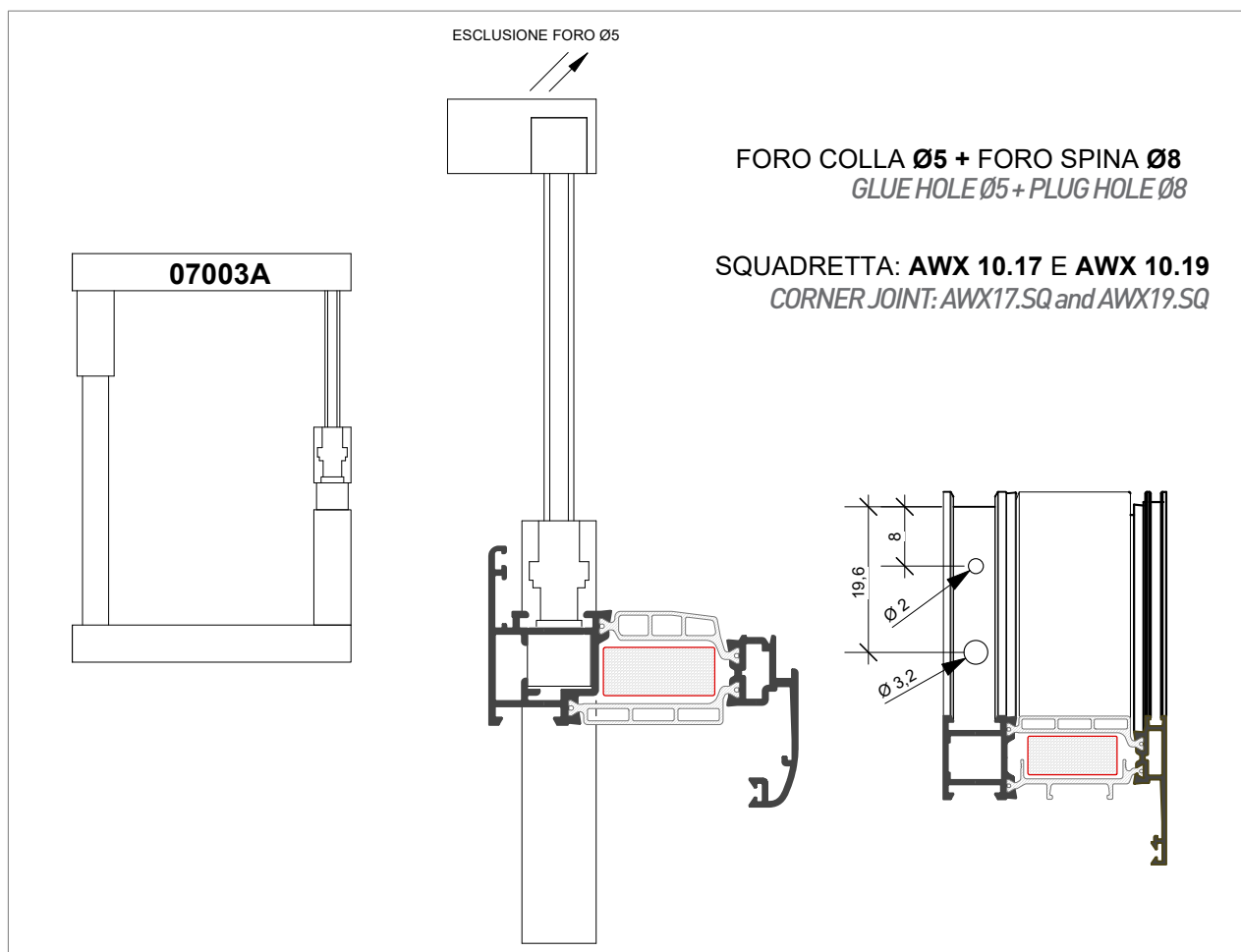
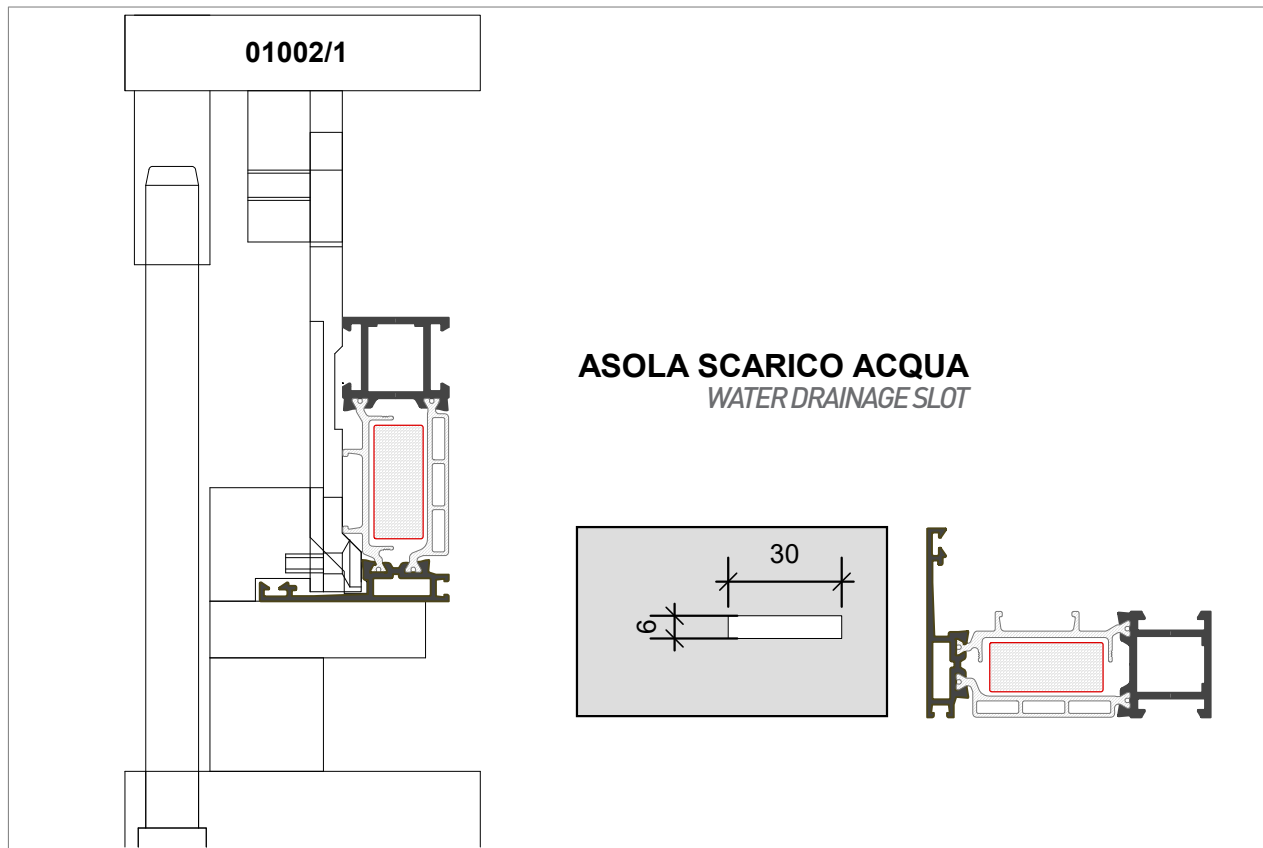

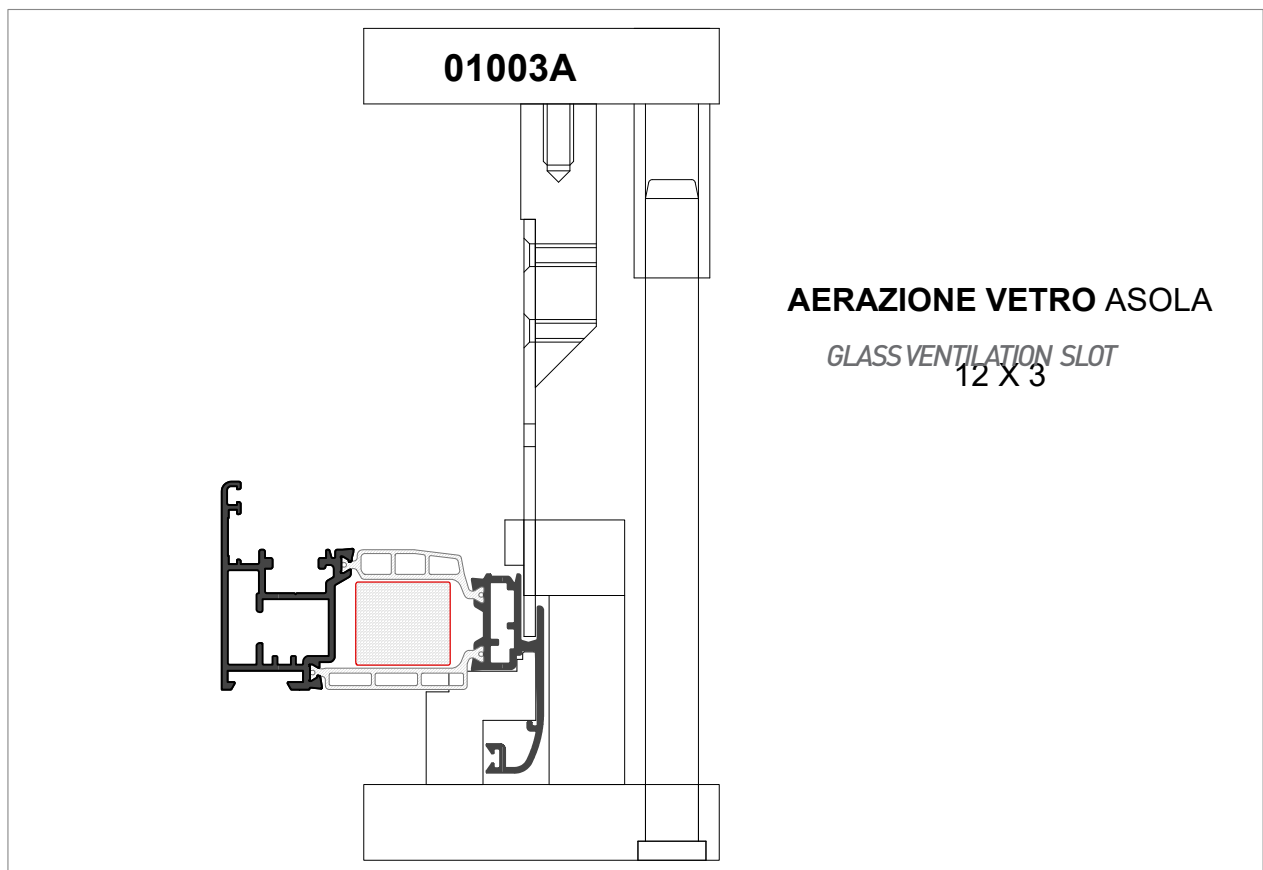
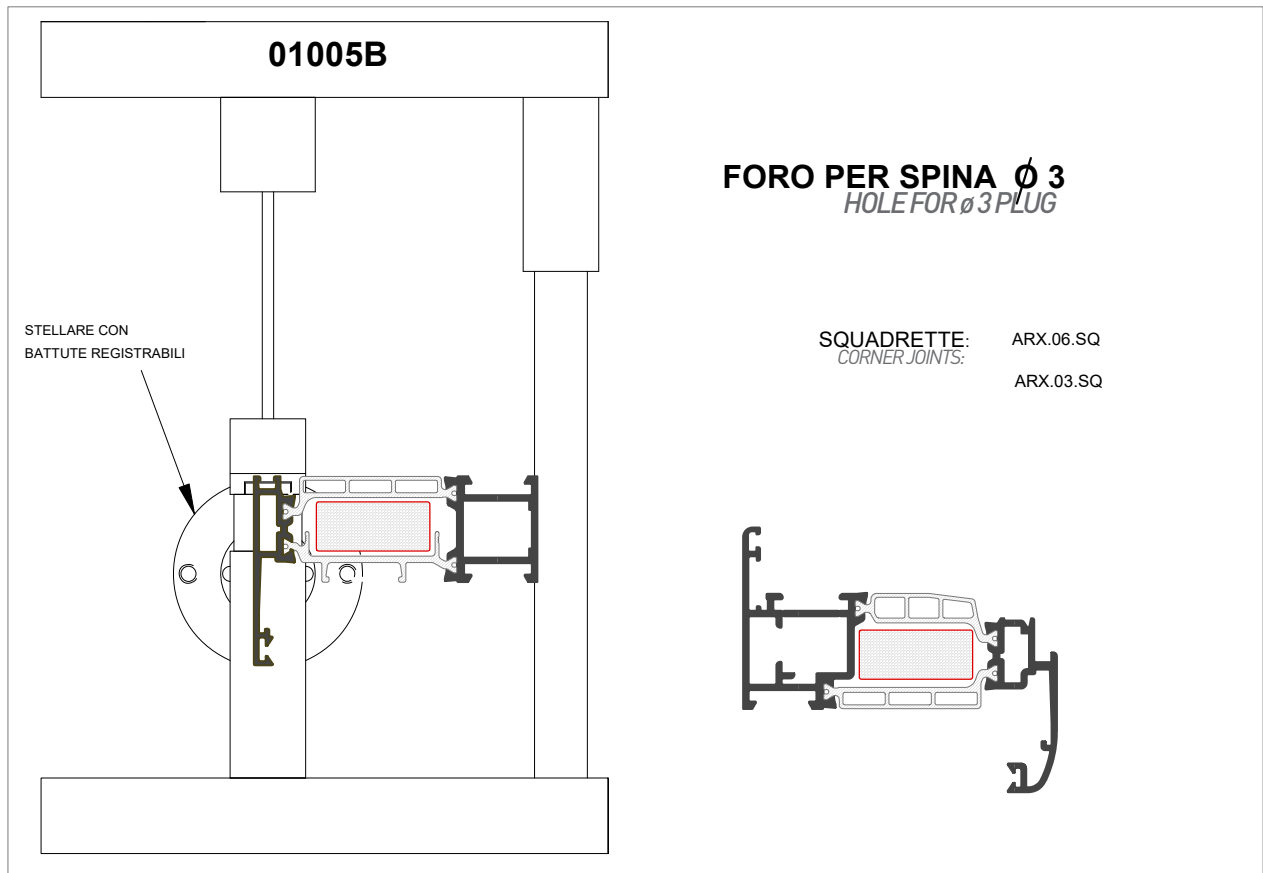

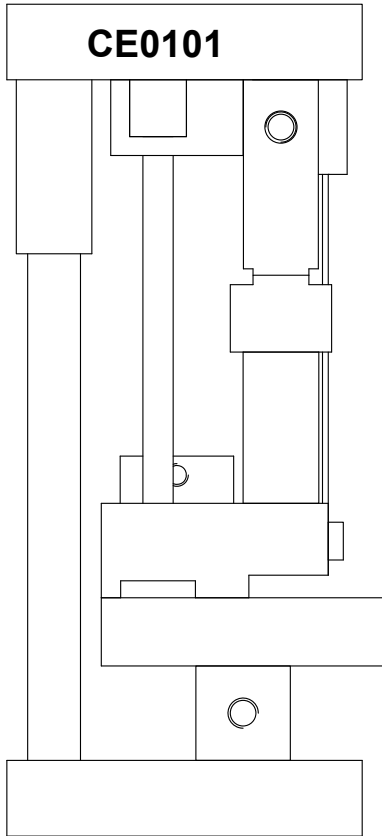

### LAVORAZIONI TOOLING

- LAVORAZIONE CREMONESE DA 104mm  
-CREMONESE BOLT TOOLING 104mm
- FORO Ø8 DI TESTA E PASSANTE, DOPPIO FORO DA Ø8 SU ASTINA  
Ø8 HEAD AND THROUGH HOLE, DOUBLE Ø8 HOLE ON BAR
- ASPORTAZIONE DENTINI PASSAGGIO ASTA  
REMOVAL OF BAR PASSING TEETH

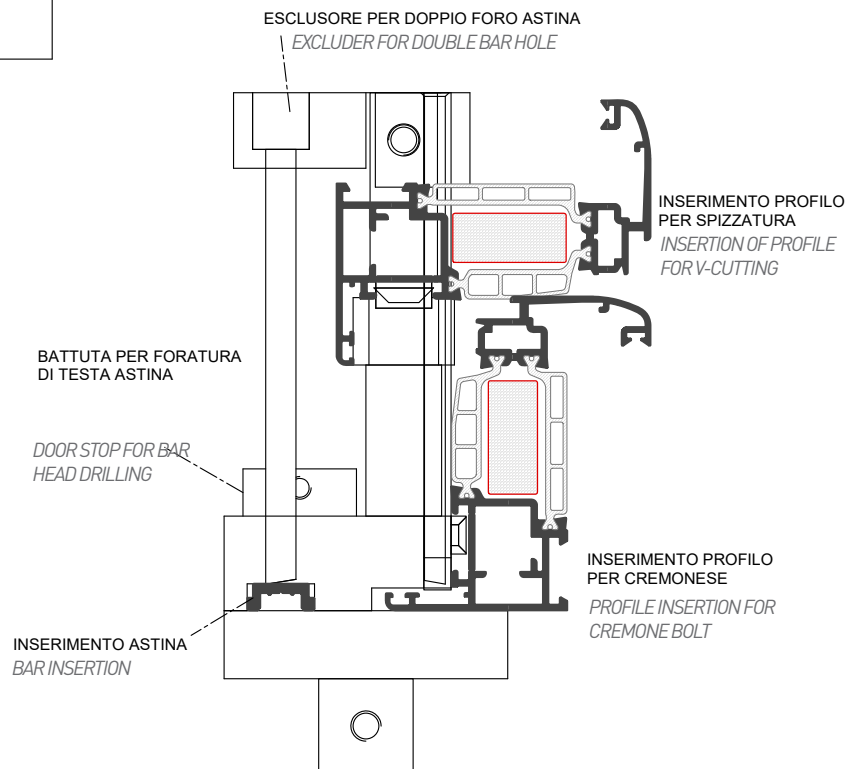

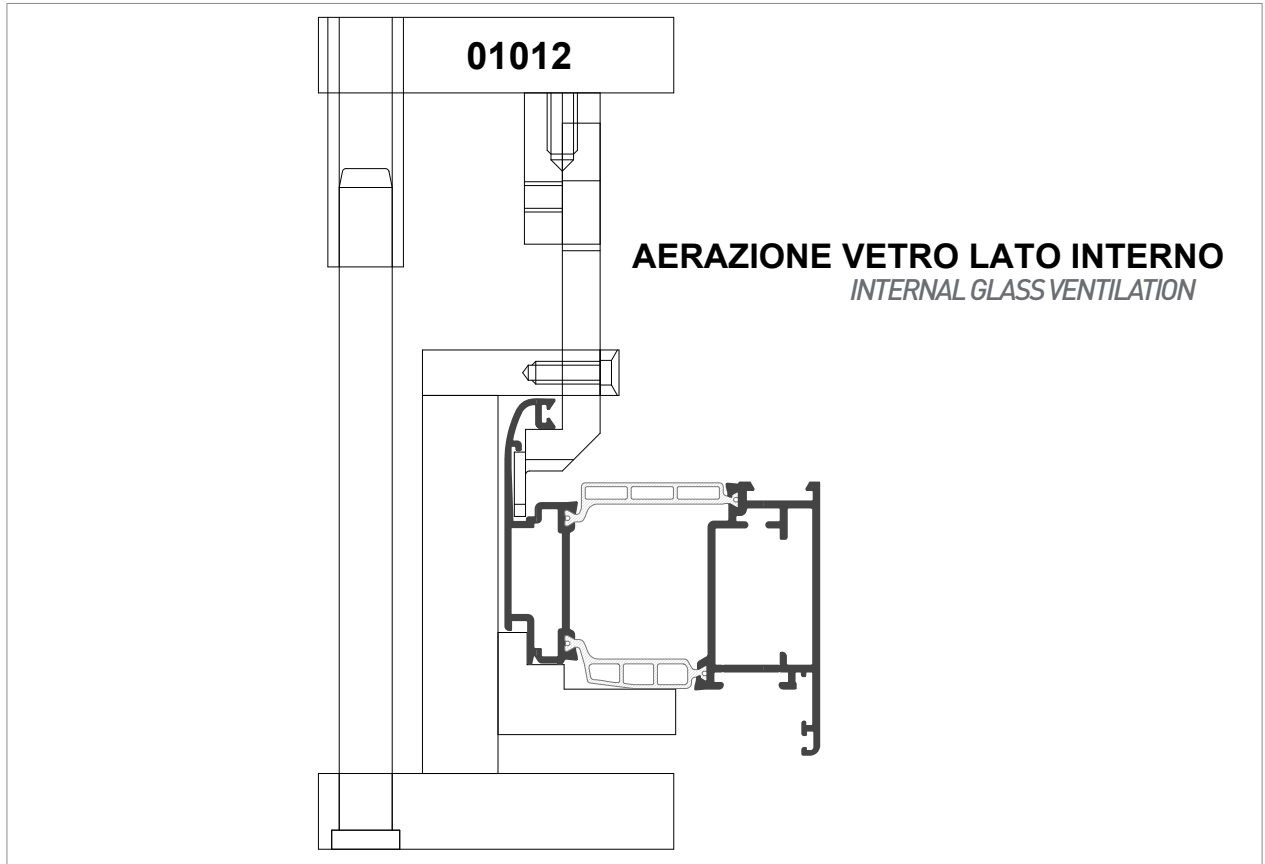

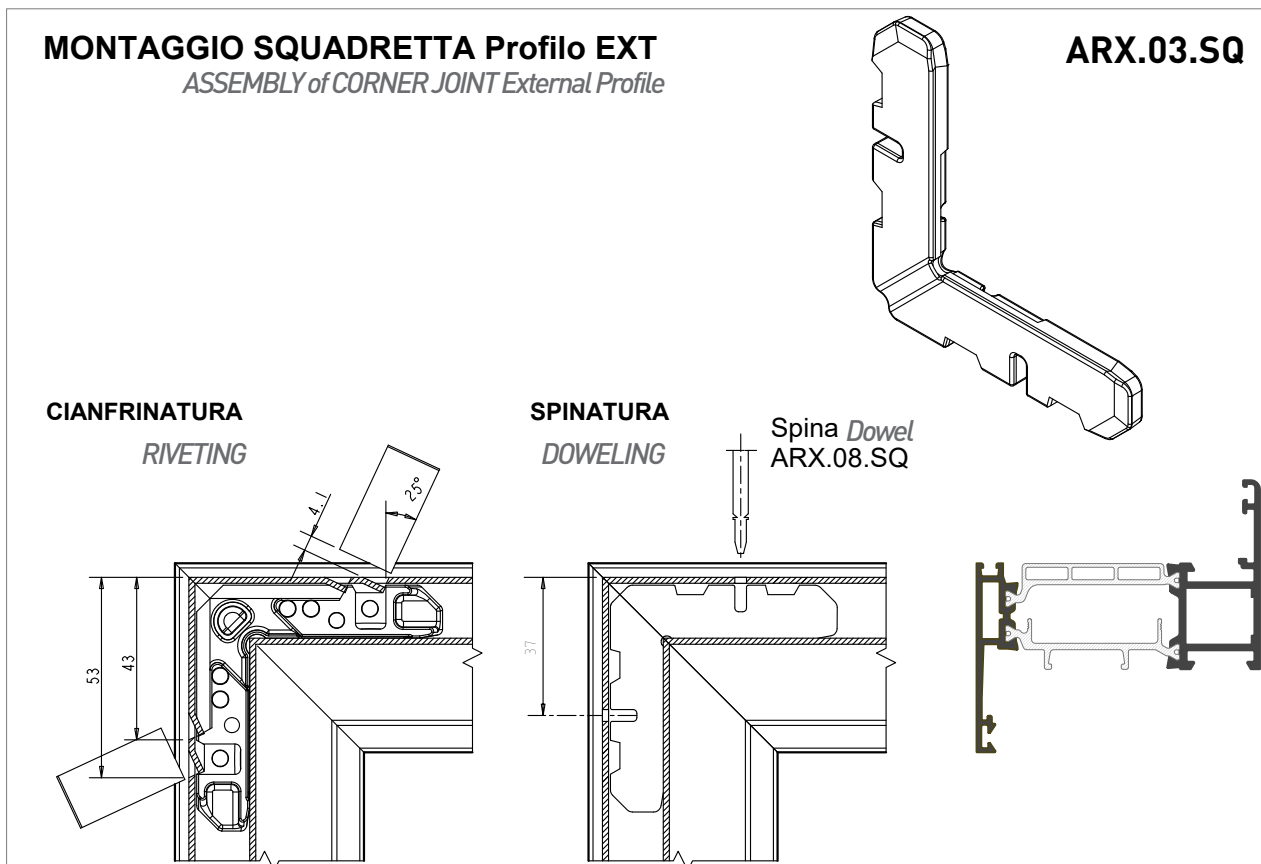
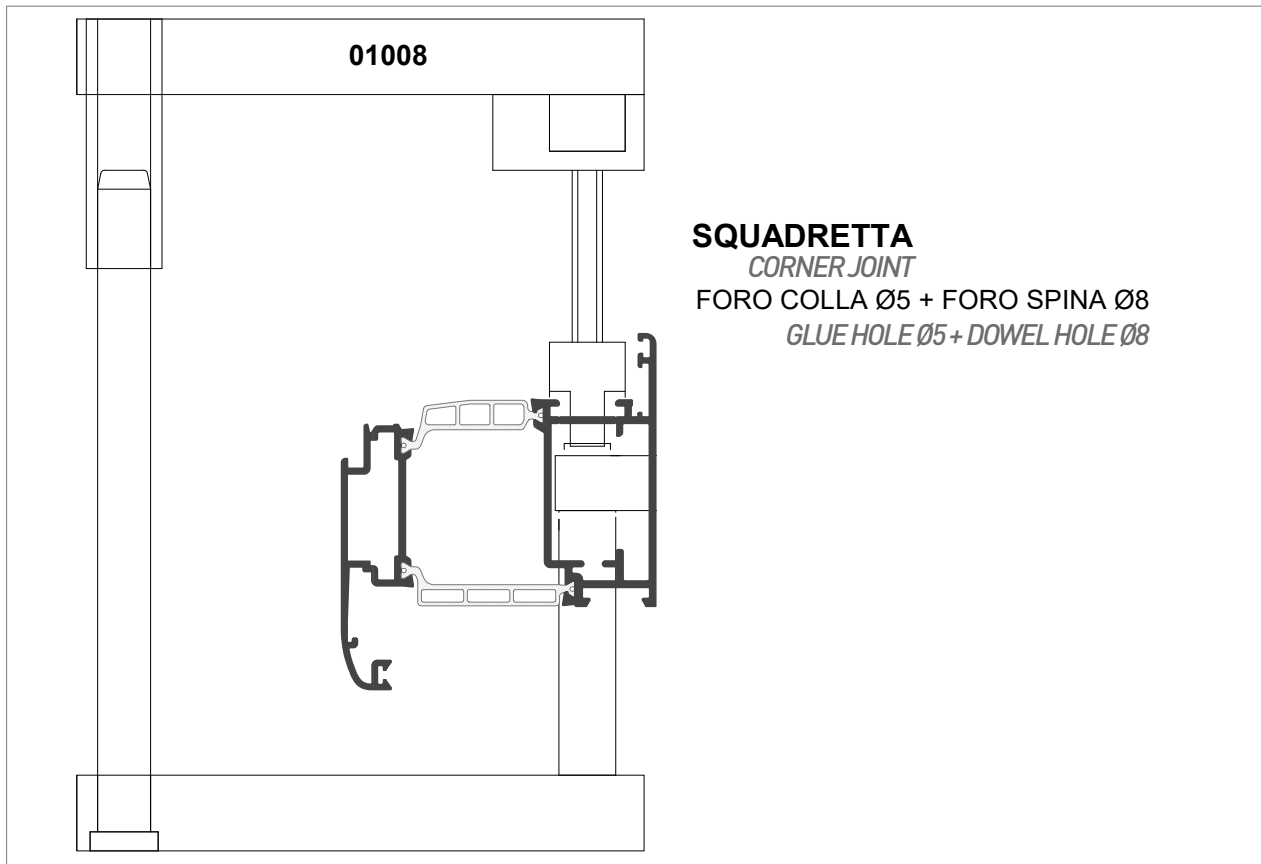

**Applicazione Accessori**

**Application of Accessories**

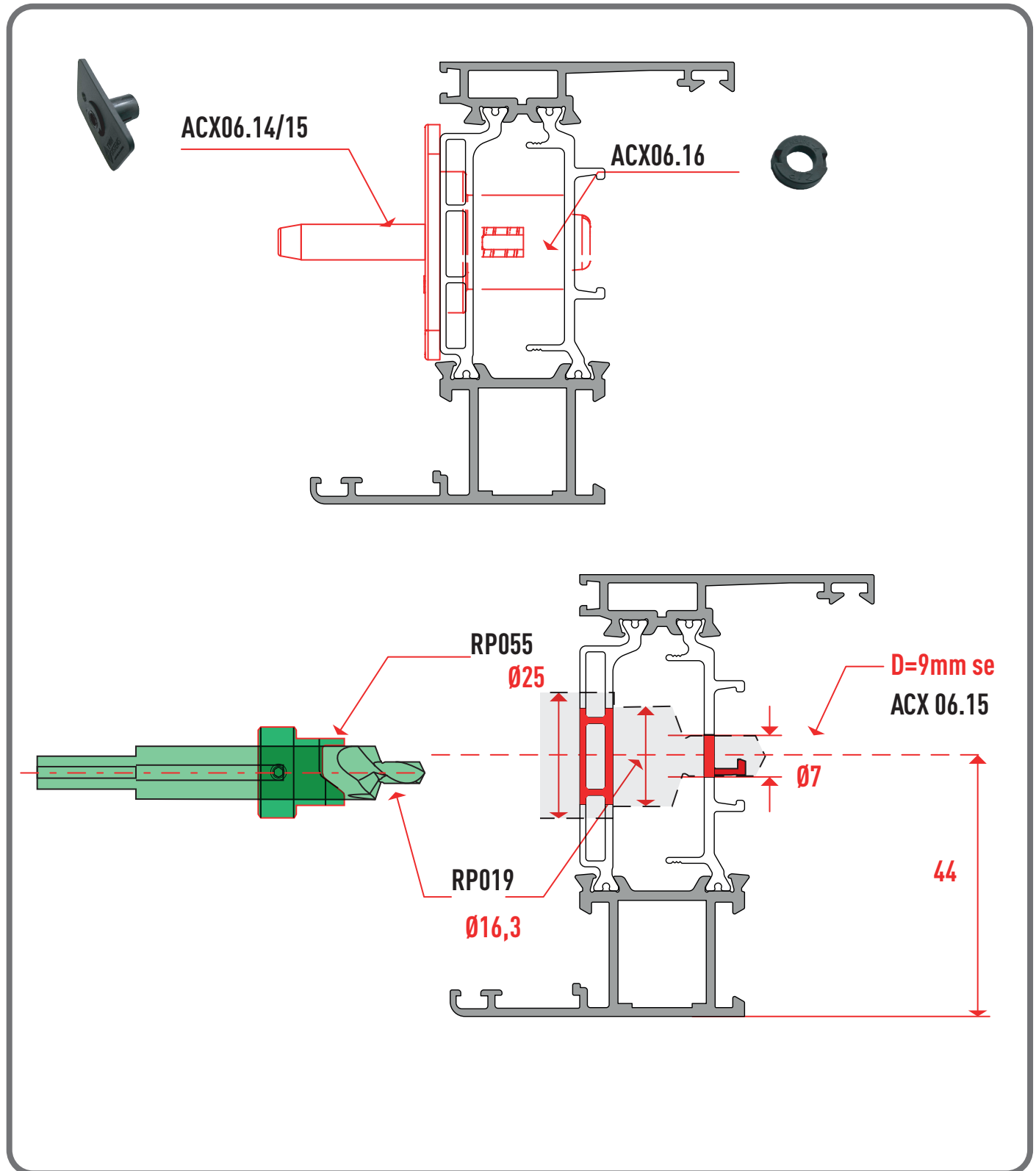

**Applicazione Accessori**

**Application of Accessories**

**MONTAGGIO SQUADRETTA Profilo EXT**

ASSEMBLY of CORNER JOINT External Profile

**ARX.06.SQ**

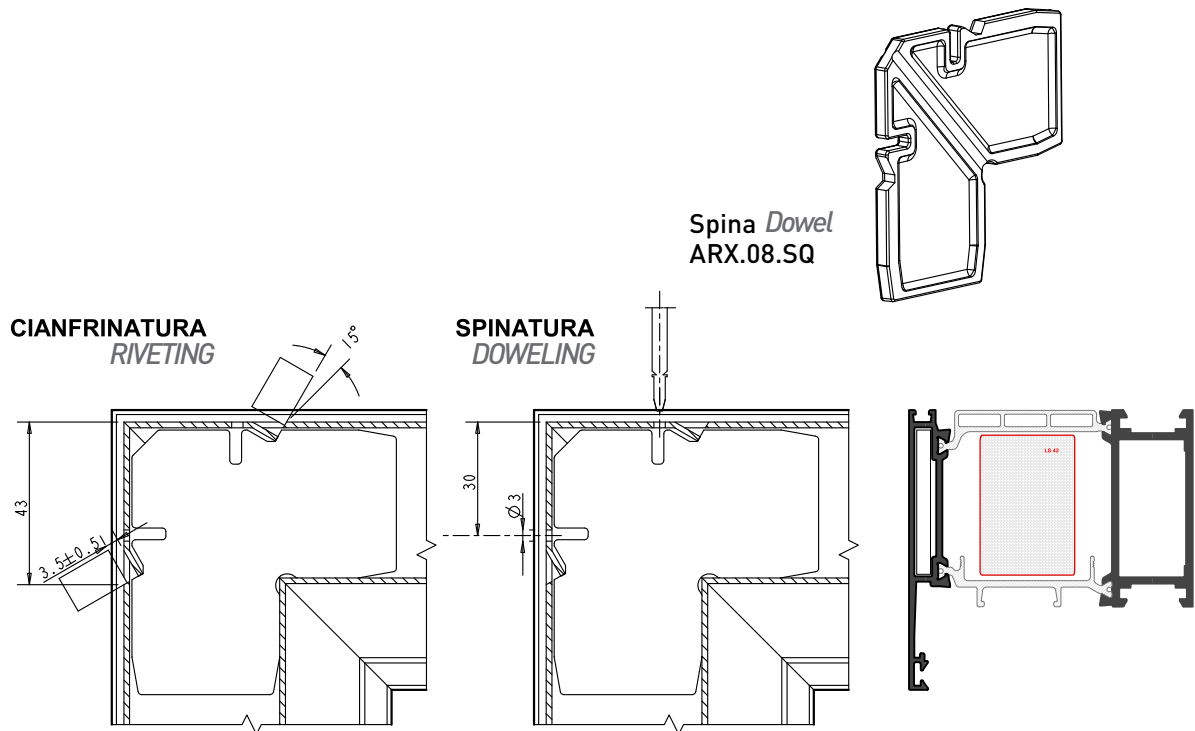

**MONTAGGIO SQUADRETTA A PULSANTE Profilo INT**

ASSEMBLY OF SLOT CORNER JOINT Internal Profile

**ACX.16.SQ**

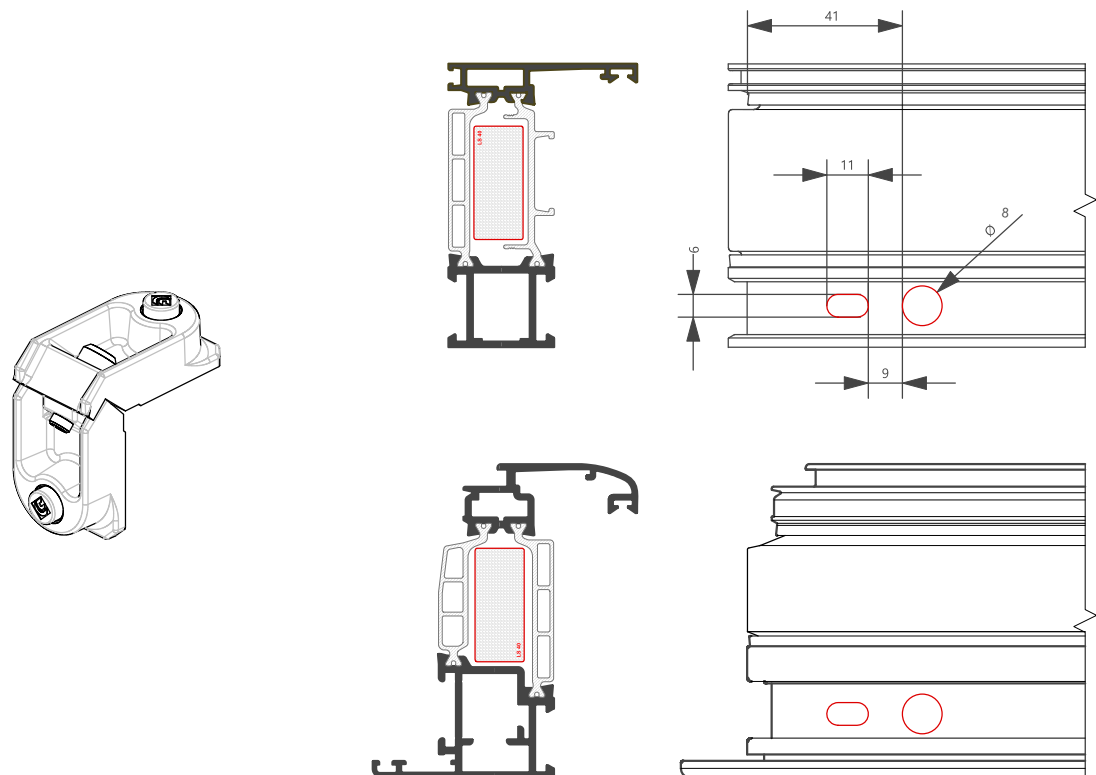

**Applicazione Accessori**

**Application of Accessories**

**MONTAGGIO SQUADRETTA SPINARE, CIANFRINARE ED AVITARE**

*ASSEMBLY of CORNER JOINT DOWELING, RIVETING, TIGHTENING*

PROFILI : **CX75.101 - CX75.201** e SIMILARI

Profiles: *CX75.101 - CX75.201 e similari*

**CIANFRINATURA** Coltello 10 mm  
*RIVETING Knife 10 mm*

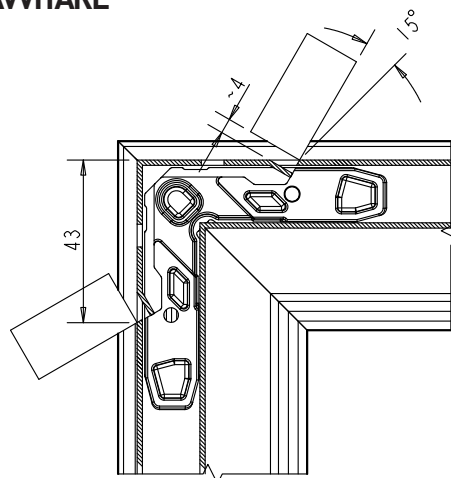

**AVITATURA** VIL M5X14\_D8  
*TIGHTENING VIL M5X14\_D8*

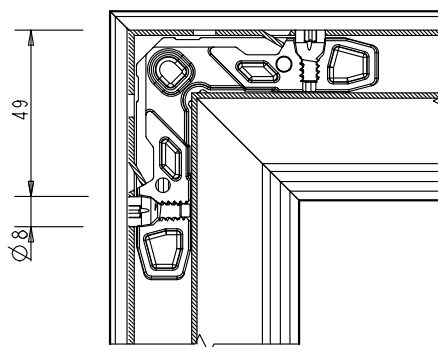

**SPINATURA**  
SPINA ARX.07.SQ [LM0088]  
*DOWELING*  
*DOWEL ARX.07.SQ*  
*[LM0088] M5X14\_D8*

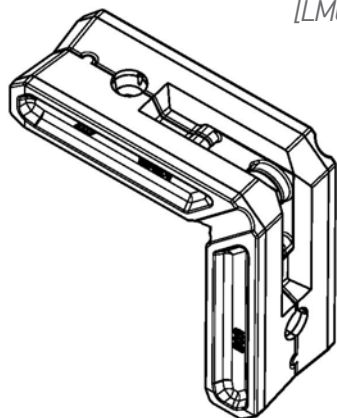

**Art. AWX.19.SQ**

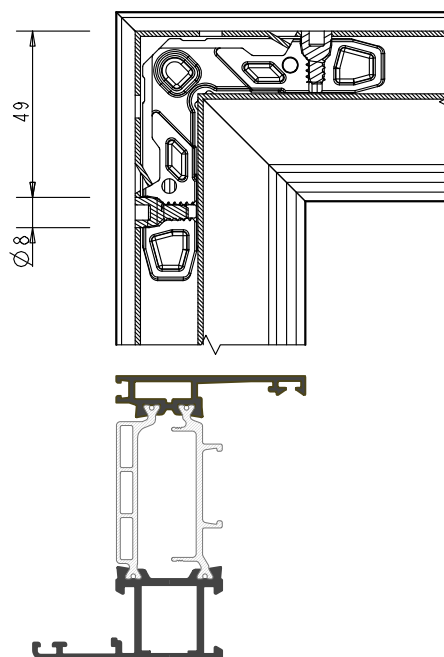

**Applicazione Accessori**

**Application of Accessories**

**MONTAGGIO SQUADRETTA SPINARE, CIANFRINARE ED AVVITARE**

ASSEMBLY of CORNER JOINT DOWELING, RIVETING, TIGHTENING

PROFILI : CX75.105 - CX75.202 e SIMILARI

Profiles: CX75.105 - CX75.202 e similari

**SPINATURA**

SPINA ARX.07.SQ [LM0088]

DOWELING

DOWEL ARX.07.SQ [LM0088] M5X14\_D8

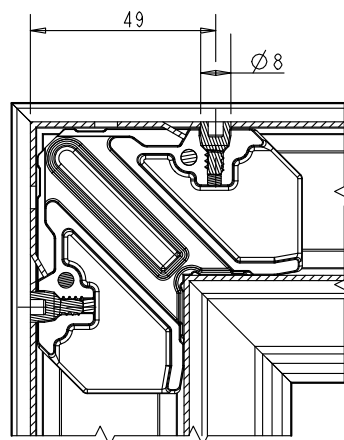

**AVVITATURA VIL M5X14\_D8**

TIGHTENING VIL M5X14\_D8

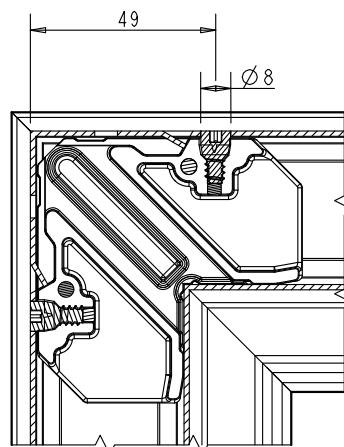

**CIANFRINATURA Coltello 10 mm**

RIVETING Knife 10 mm

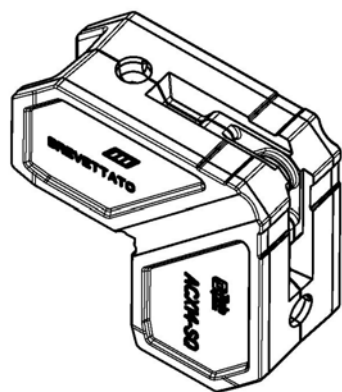
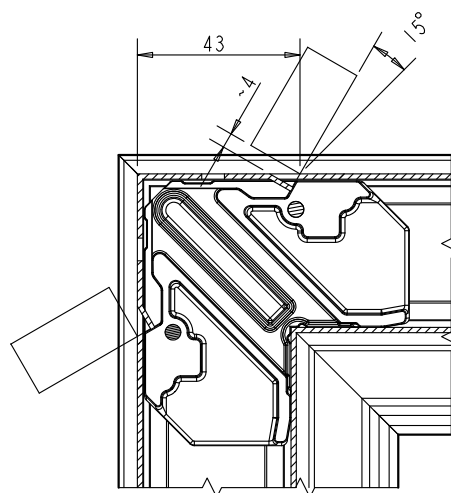

**Art. AWX.17.SQ**

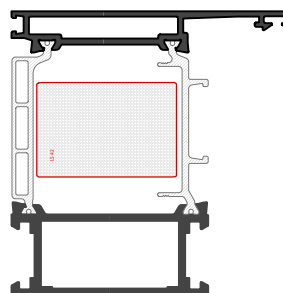

**Applicazione Accessori**

**Application of Accessories**

**ACX.60.SQ**

Giunzione a "T" o a croce H=14,4mm  
"T" or "Cross" Joint

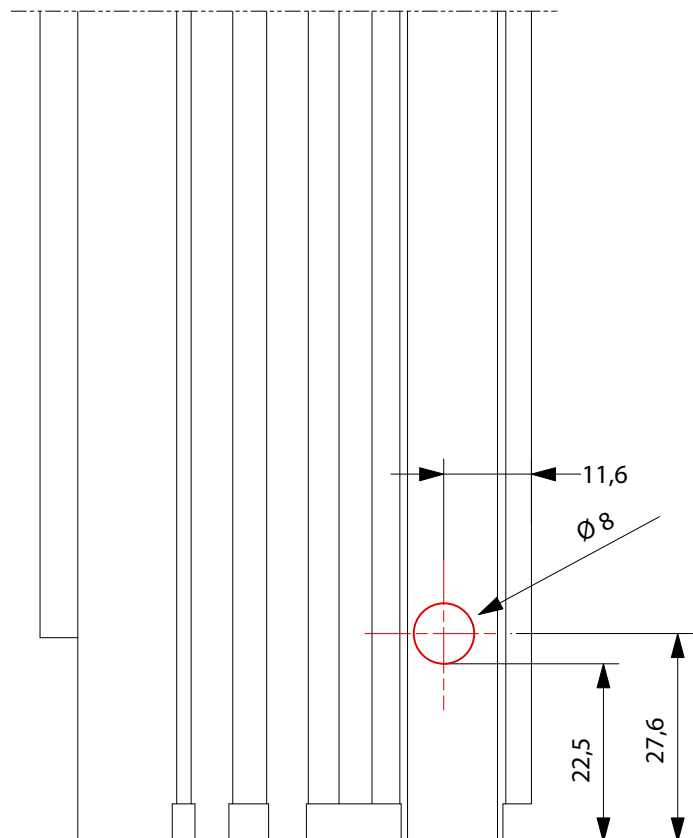
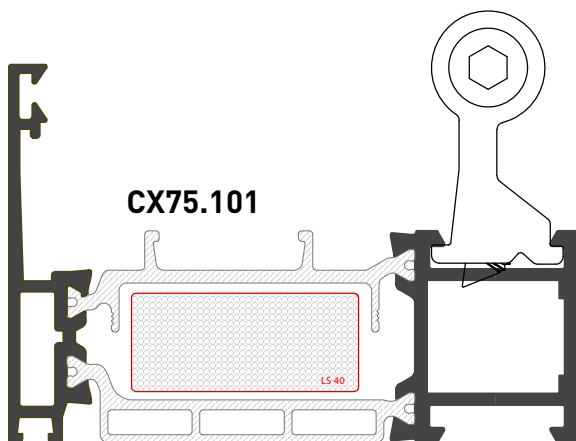
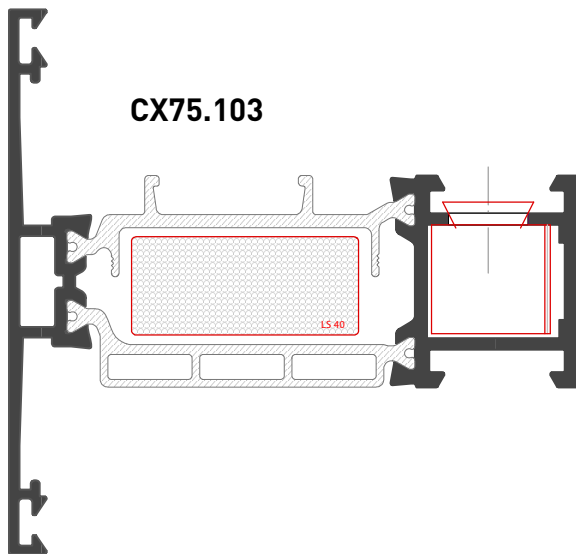
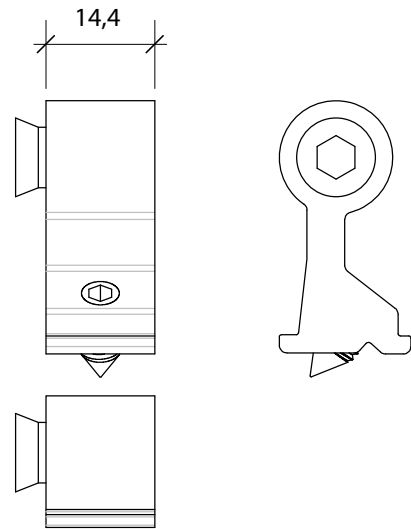
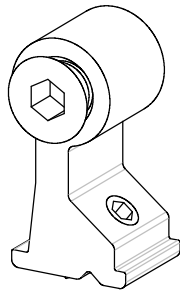

**Applicazione Accessori**

**Application of Accessories**

**ACX.61.SQ**

Giunzione a "T" o a croce H=34,8 mm

"T" or "Cross" Joint

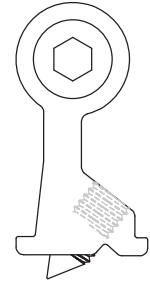
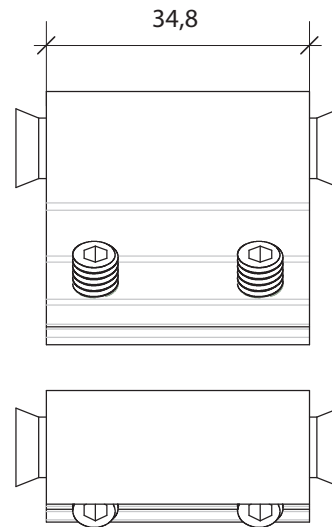
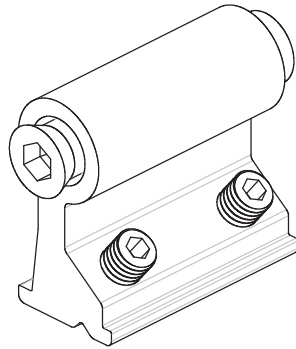

**CX75.107**

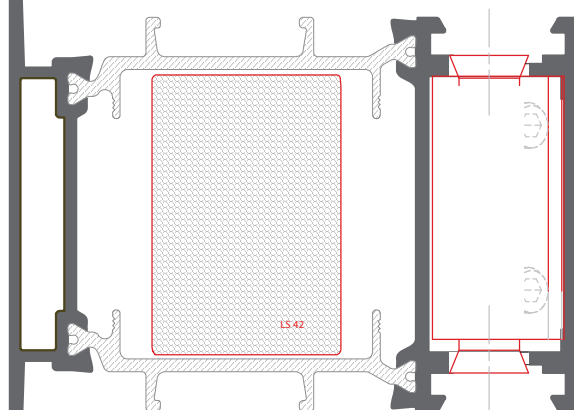

**CX75.101**

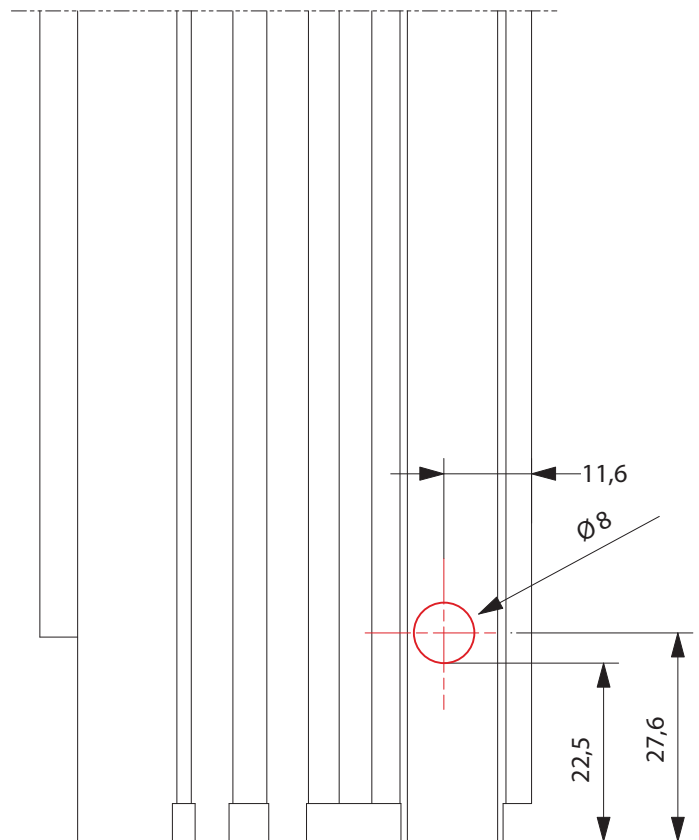
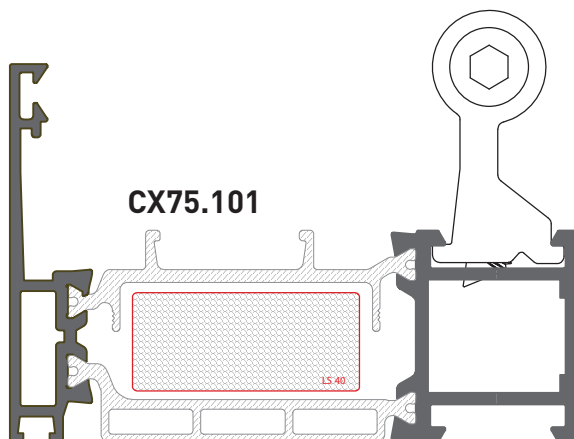

**Applicazione Accessori**

**Application of Accessories**

**MONTAGGIO SQUADRETTA** *ASSEMBLING CORNER JOINT*

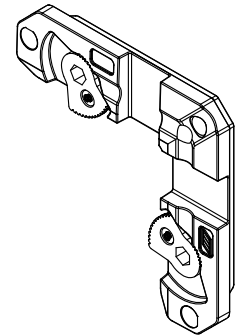
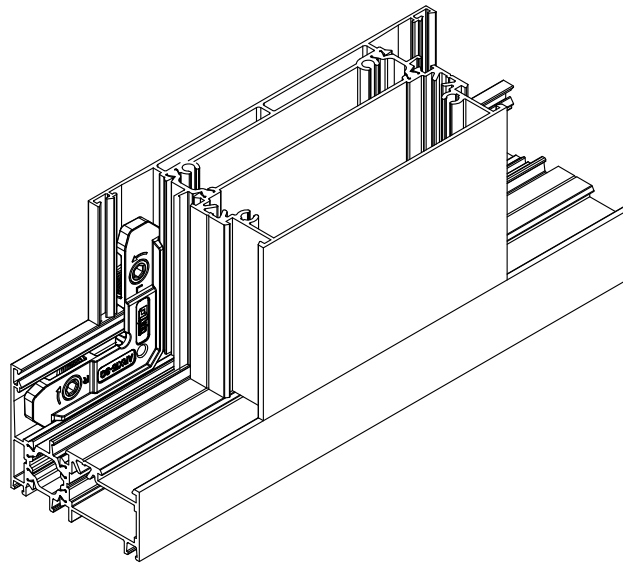
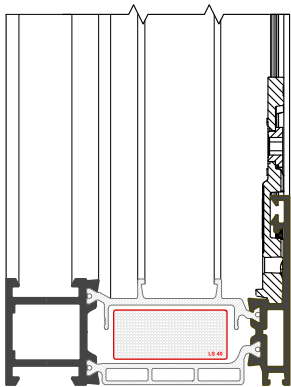

Art. **ARX.15.SQ**

Taglio a 45° o a 90° parti fisse *45° CUT or 90° for FIXED PARTS*

**ARX.15.SQ**

**MONTAGGIO CAVALLOTTO**



**ACX.47.SQ**

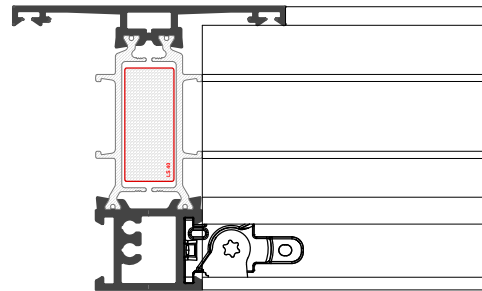

**MONTAGGIO CAVALLOTTO**

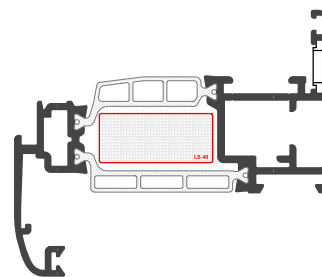
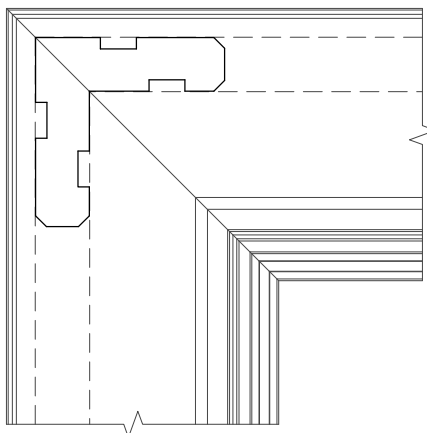

**ARX.10.SQ**

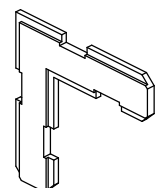

**Applicazione Accessori**

**Application of Accessories**

**MONTAGGIO SQUADRETTA**  
*ASSEMBLING CORNER JOINT*

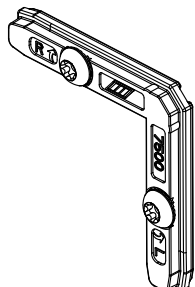

**ARX.11.SQ**

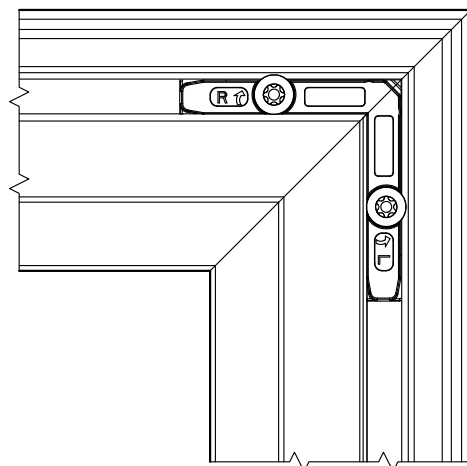
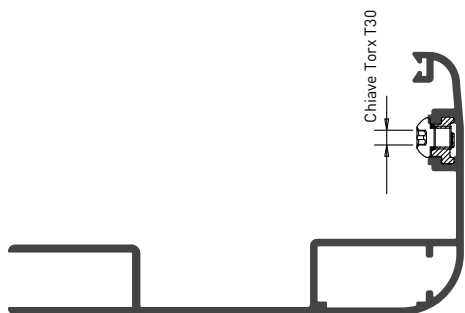

**MONTAGGIO SQUADRETTA**  
*ASSEMBLING CORNER JOINT*

**Allineamento esterno ante con rientro 13mm. traversi**  
*External Sashes Alignment. Cross Profiles Return: 5 mm.*

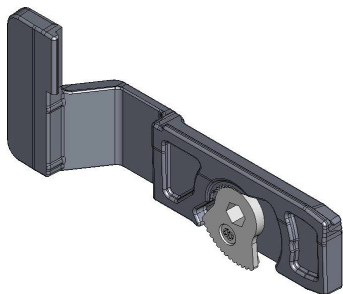

**SQUADRETTA DI ALLINEAMENTO SX**  
*LEFT Alignment Corner Joint*

**ARX.58.SQ SX**

**ARX.58.SQ DX**

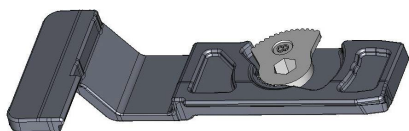

**SQUADRETTA DI ALLINEAMENTO DX**  
*RIGHT Alignment Corner Joint*

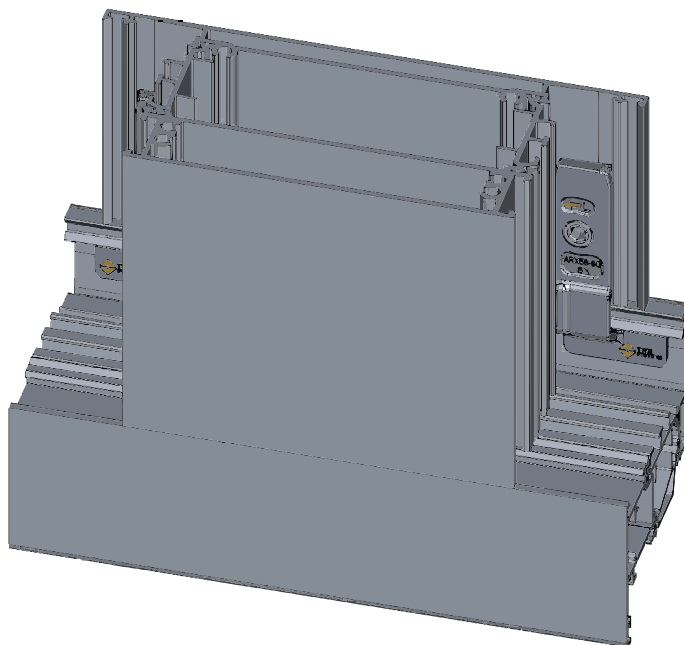

**Applicazione Accessori**

**Application of Accessories**

Terminale asta  
BAR Terminal



**ACX.03.12**

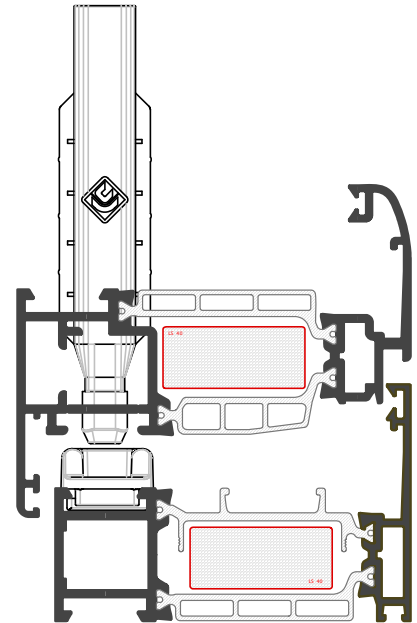
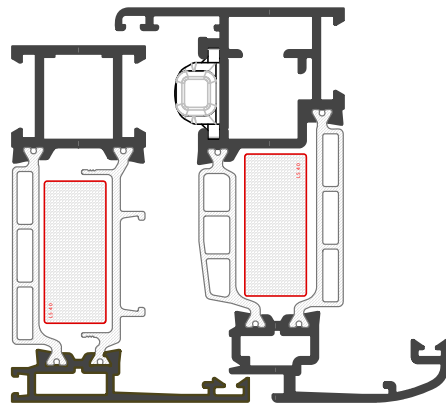

**ACX.03.18**

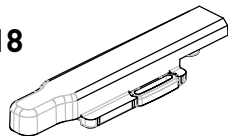

Terminale asta in zama  
ZAMAC Bar Terminal

**ACX.08.13**

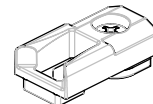

Incontro asta singola in zama  
Single Zamac Bar Rest Plate

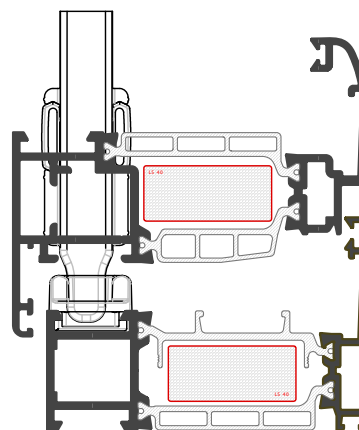
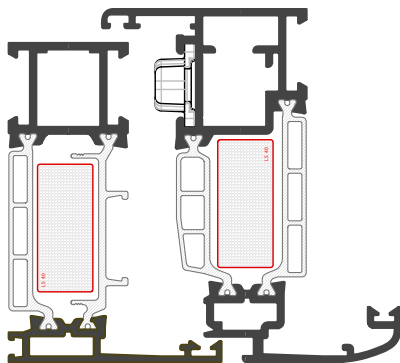

**Applicazione Accessori**

**Application of Accessories**

**SLIM**

**ACX.03.70**

**Catenaccio a comando diretto SIRIO**  
*SIRIO direct bolt*

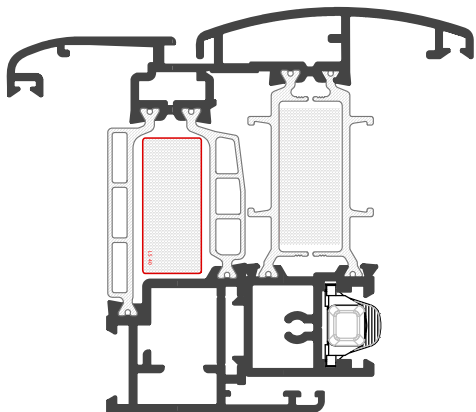
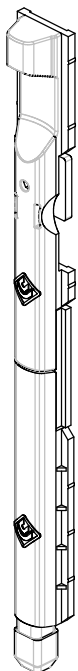

**ACX.08.44**

**Kit Catenacci a leva per anta affiancata**  
*Lever Bolt kit for side by side door*

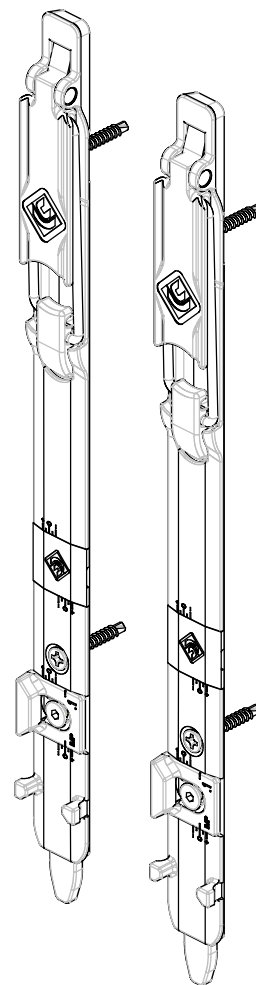
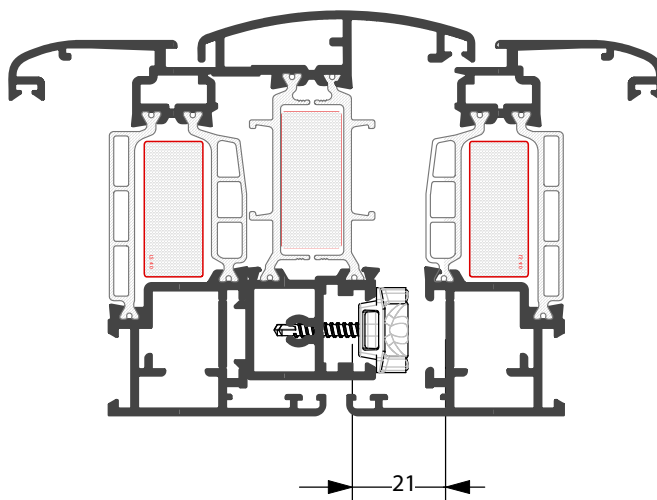

**ACX.03.71**

**Catenaccio a Leva "Mini tex"**  
*"Mini tex" Lever Bolt*

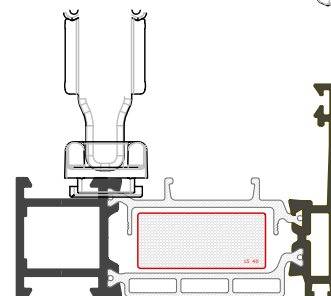
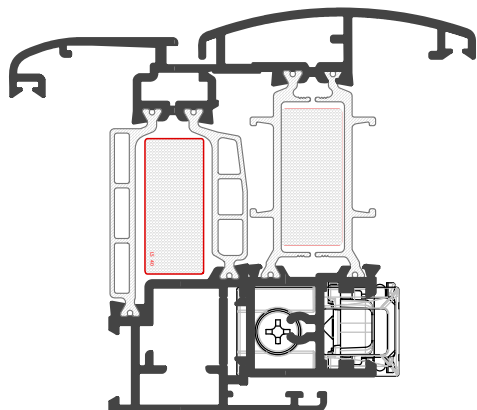
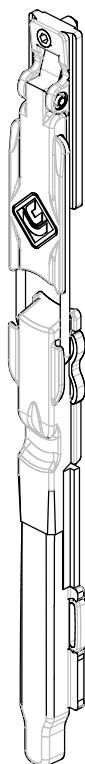

**ACX.08.13**  
**Incontro asta**  
*Bar Rest Plate*

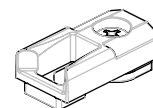

**Applicazione Accessori**

**Application of Accessories**

**ACX.03.16**

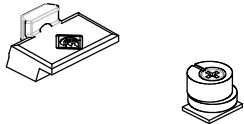

Kit di chiusura Supplementare c/Eccentrico  
*Supplementary closure kit with eccentric bolt*

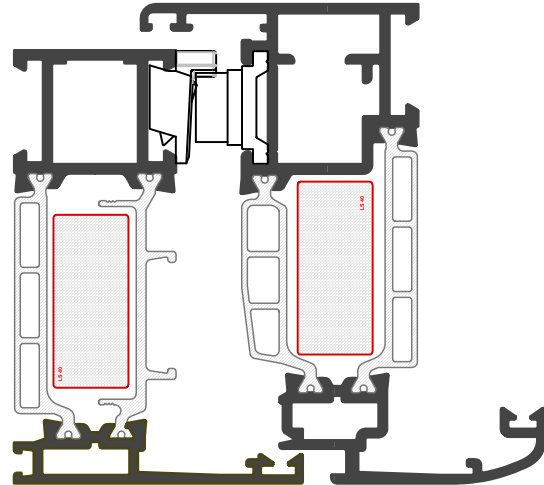

**ACX.03.63**

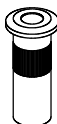

Incontro a pozzetto d=8mm.  
*Drain rest plate D=8 mm.*

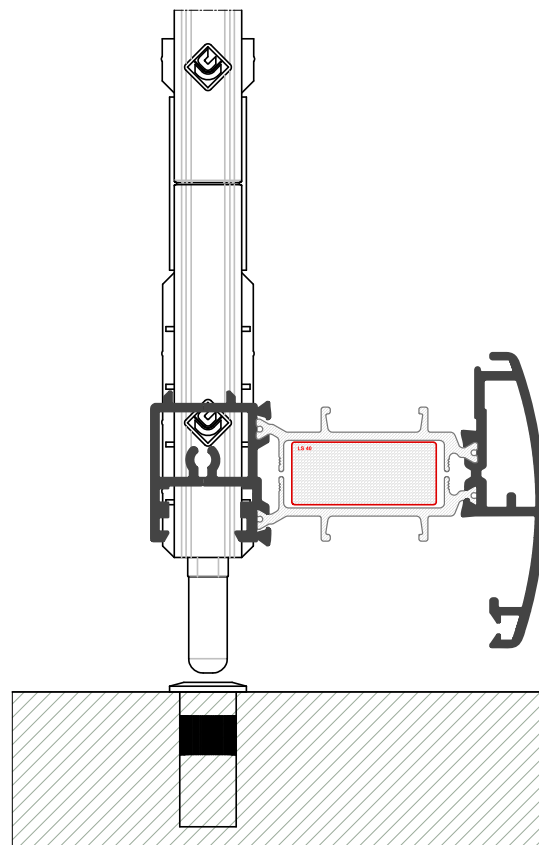



**Applicazione Accessori**

**Application of Accessories**

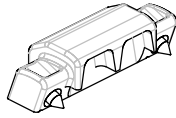

**ACX.03.19**  
Kit sostegno anta  
*Door support kit*

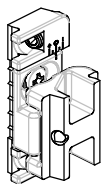
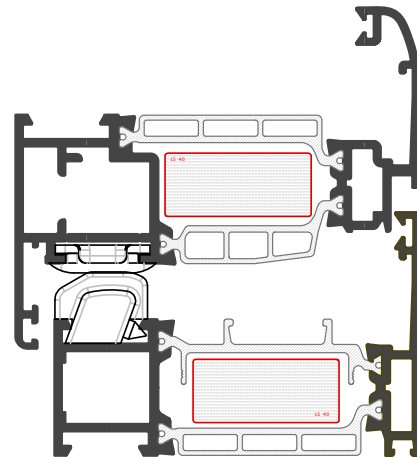

**ACX.03.29**  
Rostro regolabile  
*Adjustable Bolt*

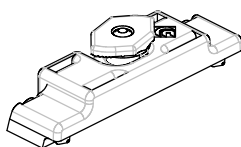
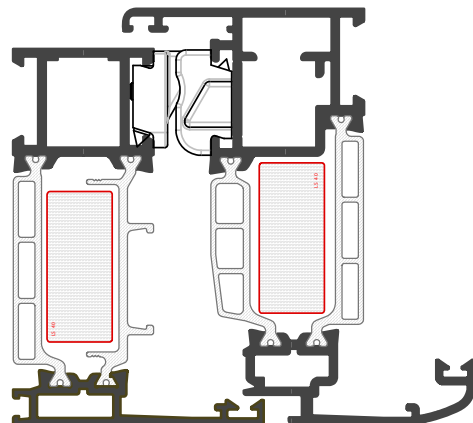

**ACX.03.15**  
Clip ferma anta  
*Rabbit Clip*

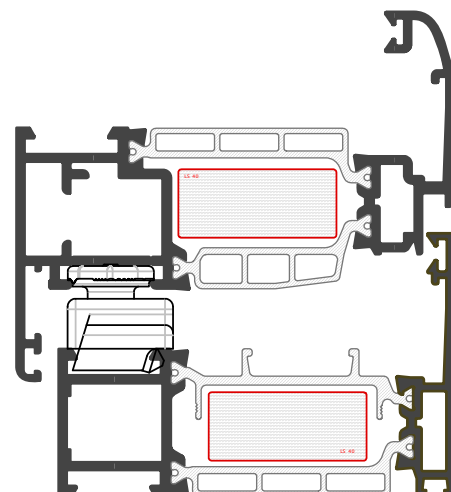

**Applicazione Accessori**

**Application of Accessories**

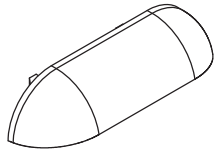

**ARX.05.01**  
**Cappetta drenaggio**  
*Drainage plug*

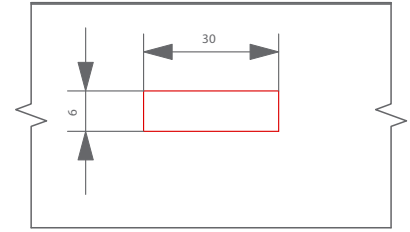
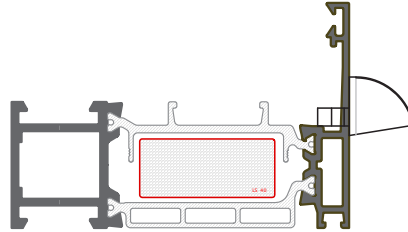

**ARX.06.02**  
**Piastrina registro Telaio**  
*Frame adjustment plate*



**ARX.06.03**  
**Registro Telaio 20 mm.**  
*Frame adjusting screw 20 mm*

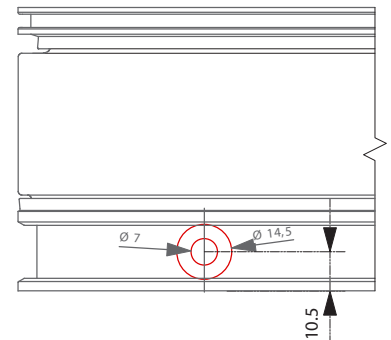
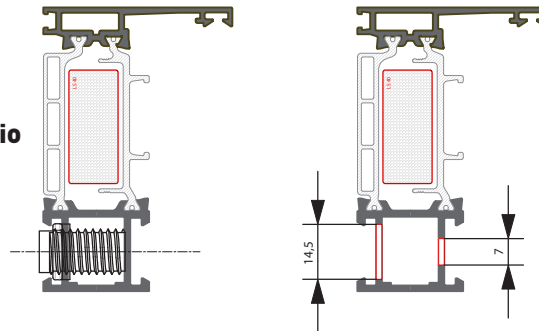

**ATTENZIONE: Applicazione valida Solo per telaio ad L**  
**ATTENTION: Application valid only for L frame**

**CX75.640**

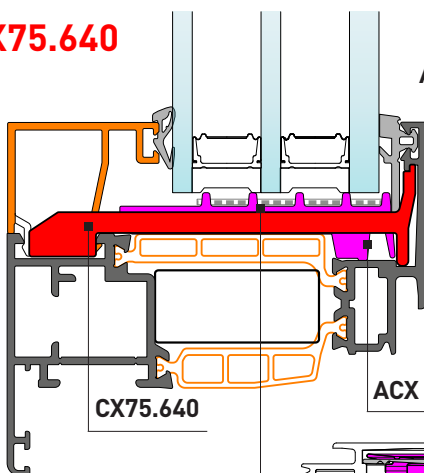

**Cuscinetto Appoggio Vetro Sp. 1mm.**  
*Glass Support Bearing 1mm thick.*

**ARX 10.05.1**

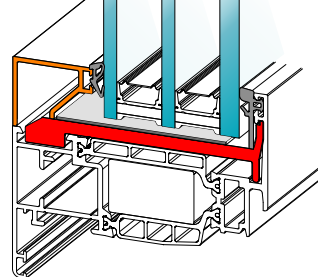

**ACX 10.81**

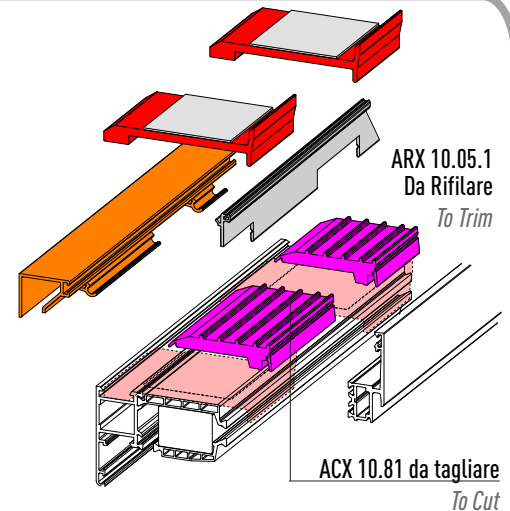
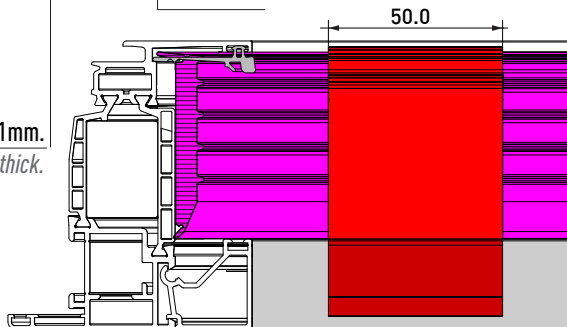

**ARX 10.05.1**  
**Da Rifilare**  
*To Trim*

**ACX 10.81 da tagliare**  
*To Cut*

**Scantonatura**  
**Fermavetro**  
*Glazing Bead*  
*Trimming*

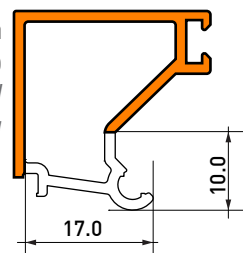

**Applicazione Accessori**

**Application of Accessories**

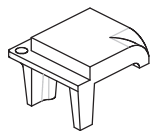

**ACX.07.02**  
Angolo fermavetro  
*Glazing bead corner*

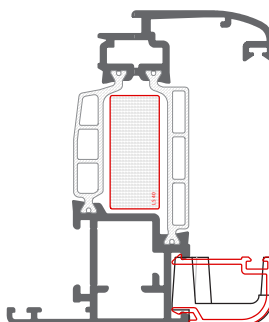
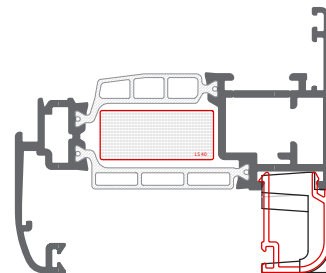
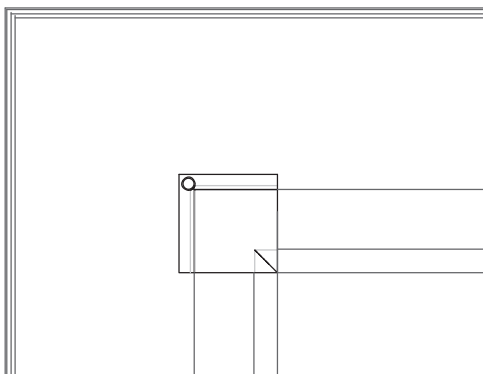

**TAPPO PER PROFLO CX75.627 (Porta a 2 ante, anta semifissa)**

*PLUG FOR PROFILE*

*(2 Sashes Door, Semi Fixed Sash)*

PROFILI: **CX75.727**

PROFILES

**Art. ARX.04.30**

**Art. ARX.04.31**



**ARX.04.70 TAPPO GOCCIOLATOIO PER PROFLO XX70.2040**

*PLUG FOR PROFILE*

PROFILI: **XX70.2040**

PROFILES

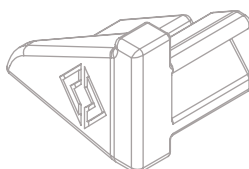

**Art. ARX.04.70**

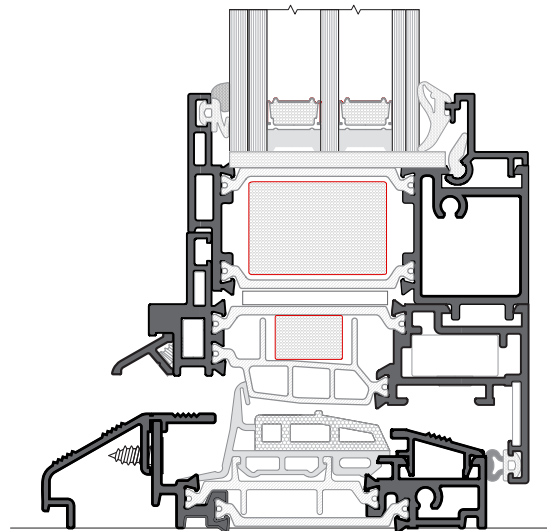

**Applicazione Accessori**

**Application of Accessories**

**Coppia Tappi di Riporto camera Europea Tondo / Dritto con pre-taglio**  
*Pair of round / straight European chamber wing plugs with pre-cutting*

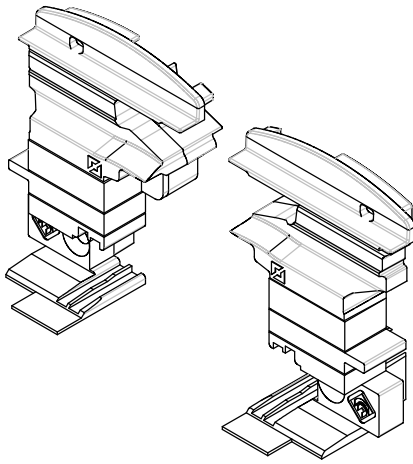

**ACX.04.54**

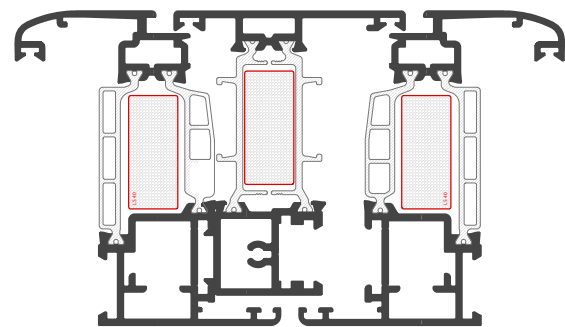
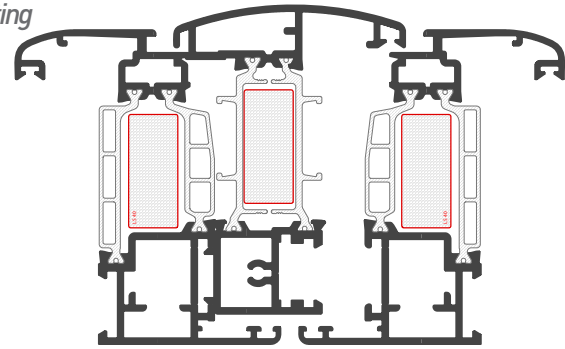

**Coppia Tappi di Riporto Ferramenta a Nastro Tondo / Dritto con pre-taglio**  
*Pair of round / straight tape hardware wing plugs with pre-cutting*

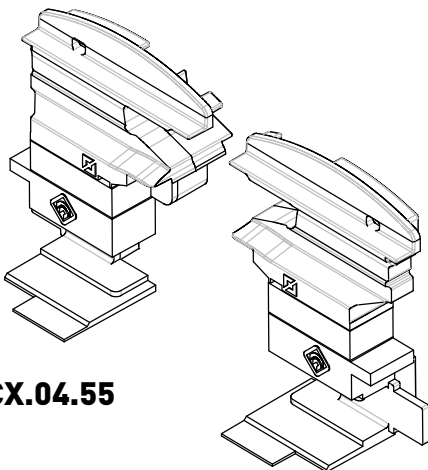

**ACX.04.55**

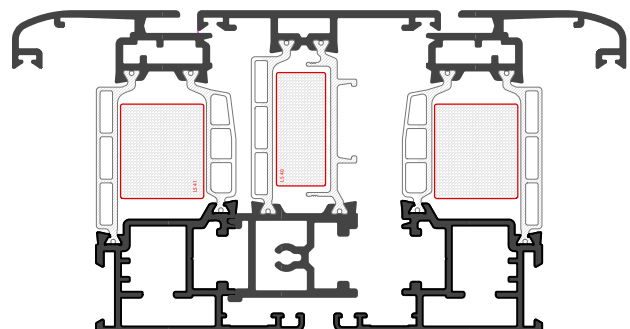
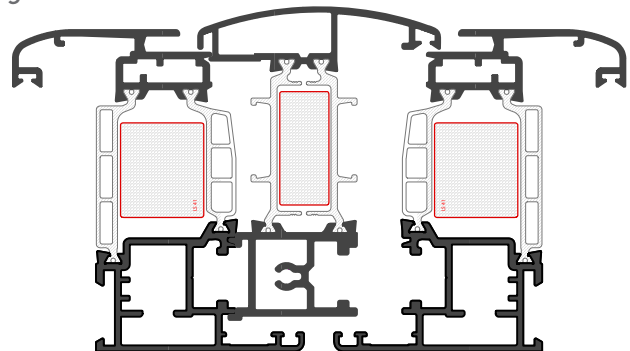

**Applicazione Accessori**

**Application of Accessories**

**Coppia Tappi di Riporto Doppia Battuta Tondo / Dritto con pre-taglio**  
*Pair of round / straight double door stop wing plugs with pre-cutting*

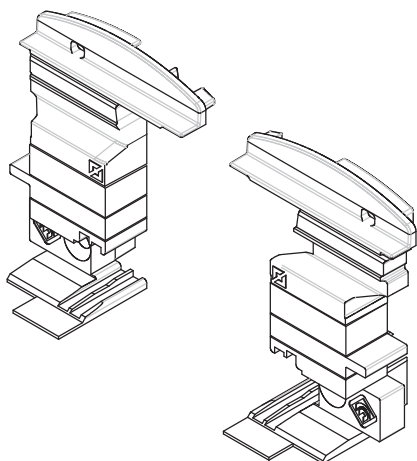

**ACX.04.56**

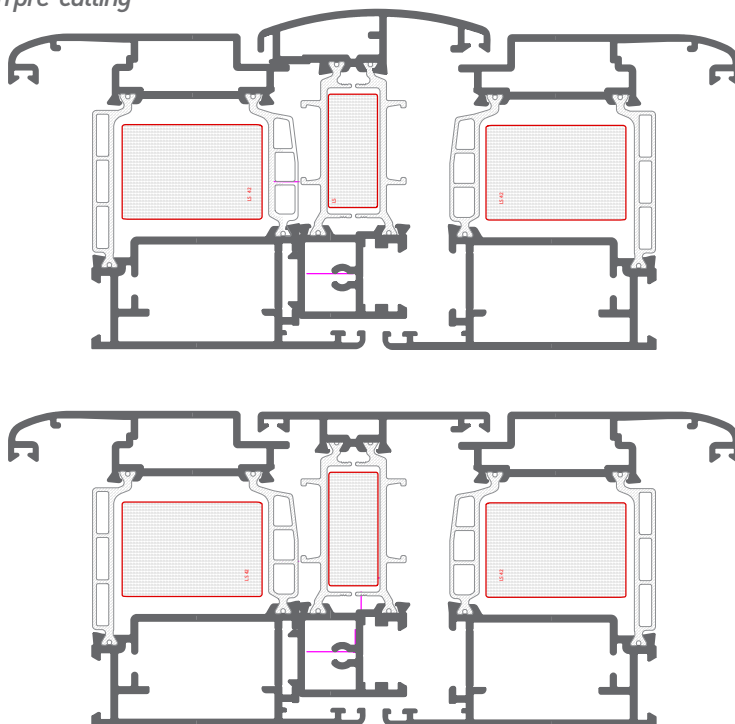

**Kit Tappi di Riporto Doppia Battuta per XX70.643**  
*Kit double sash door plugs for XX70.643*

**Art. ARX.04.60**

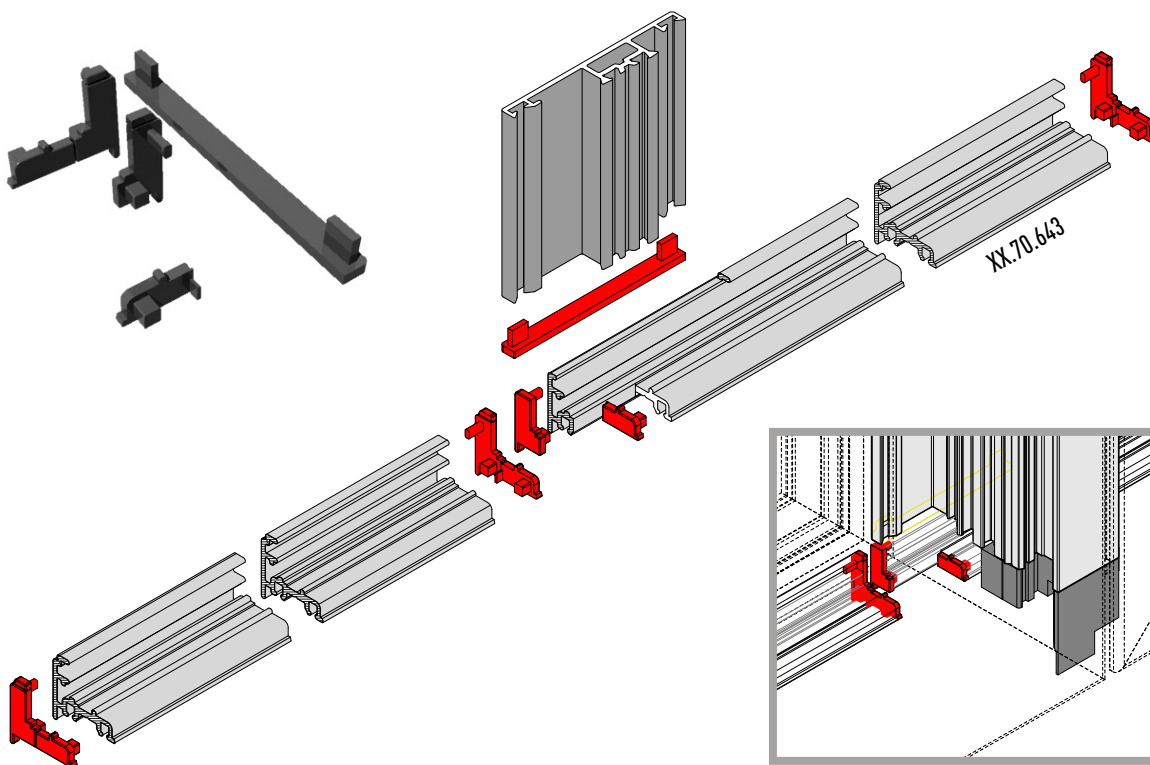

**Applicazione Accessori**

**Application of Accessories**

Art. XX70.643

**Profilo Porta Spazzolino per Anta Doppia Battuta. Apertura Esterna**  
*Brush Holder Profile for Double Stop Sash. External Opening*

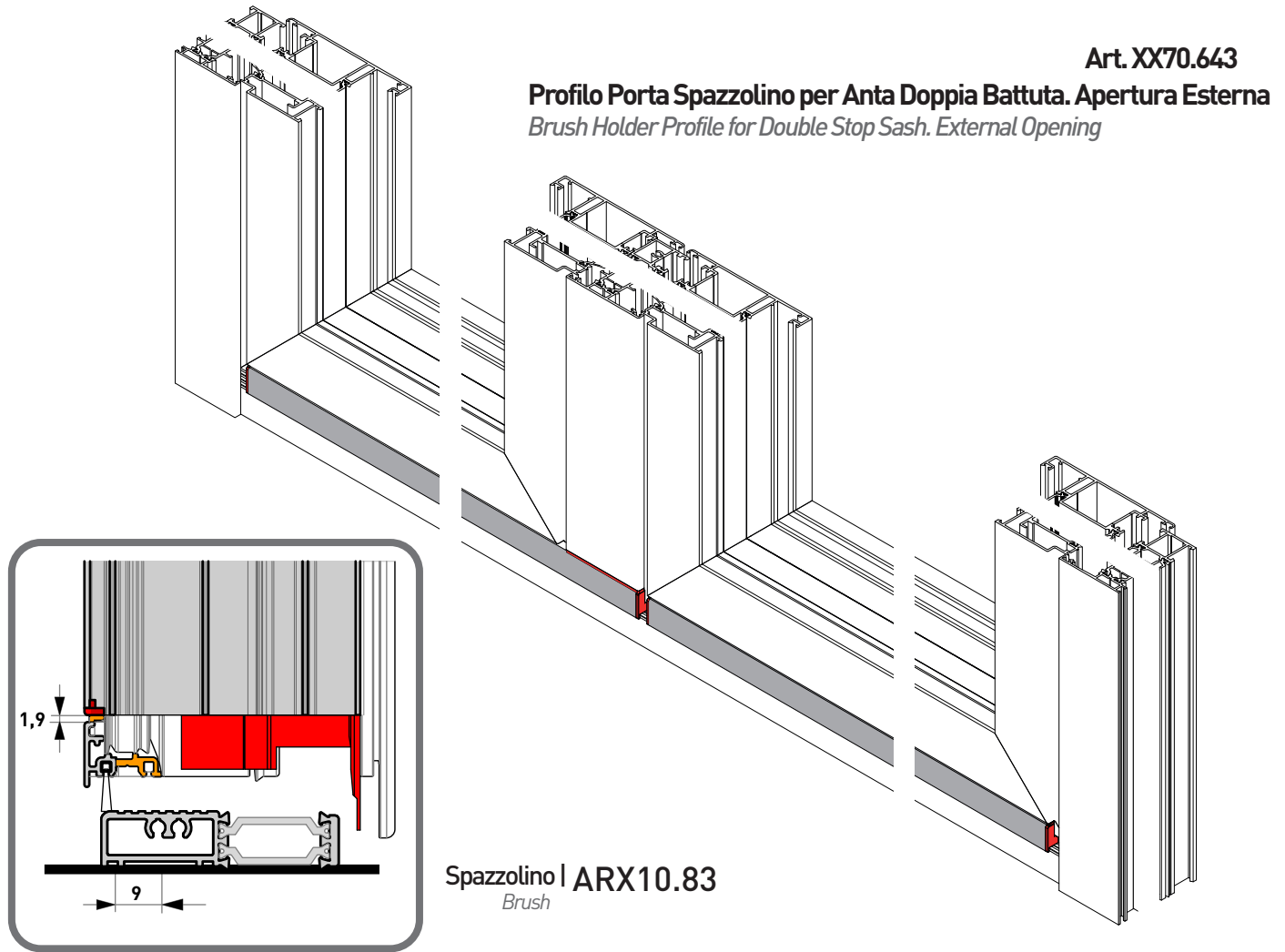

**Spazzolino | ARX10.83**  
*Brush*

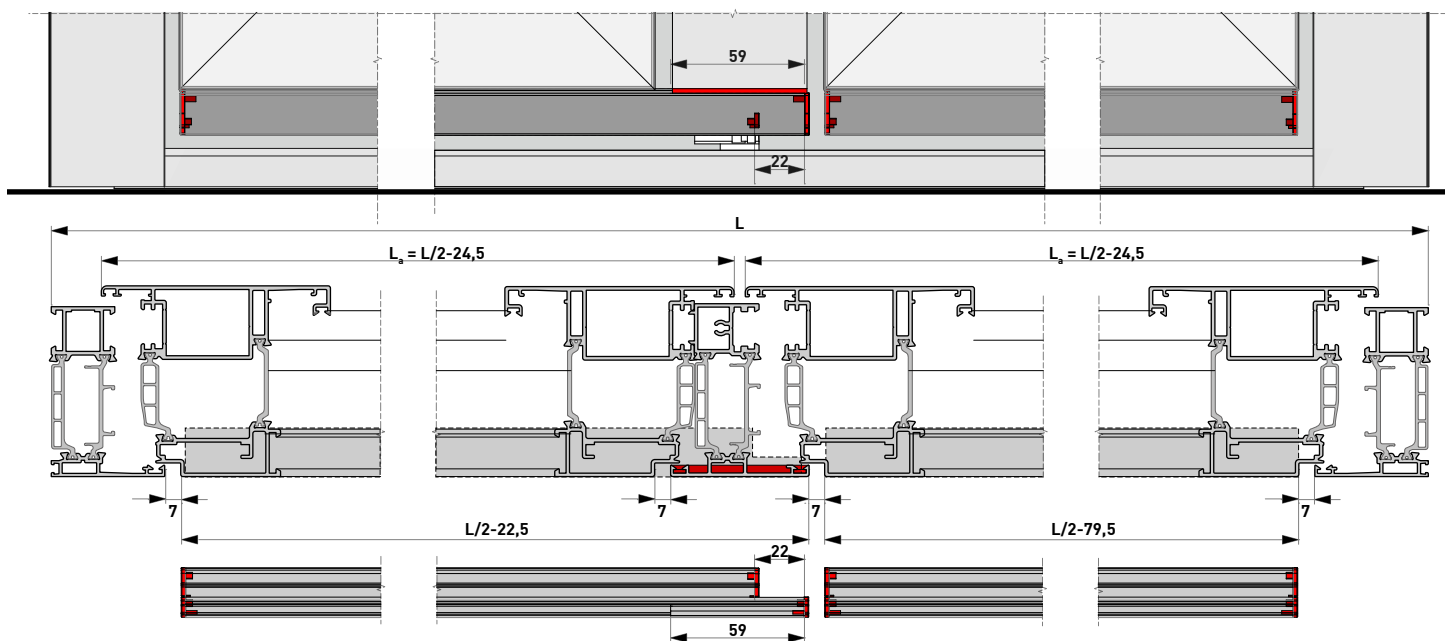

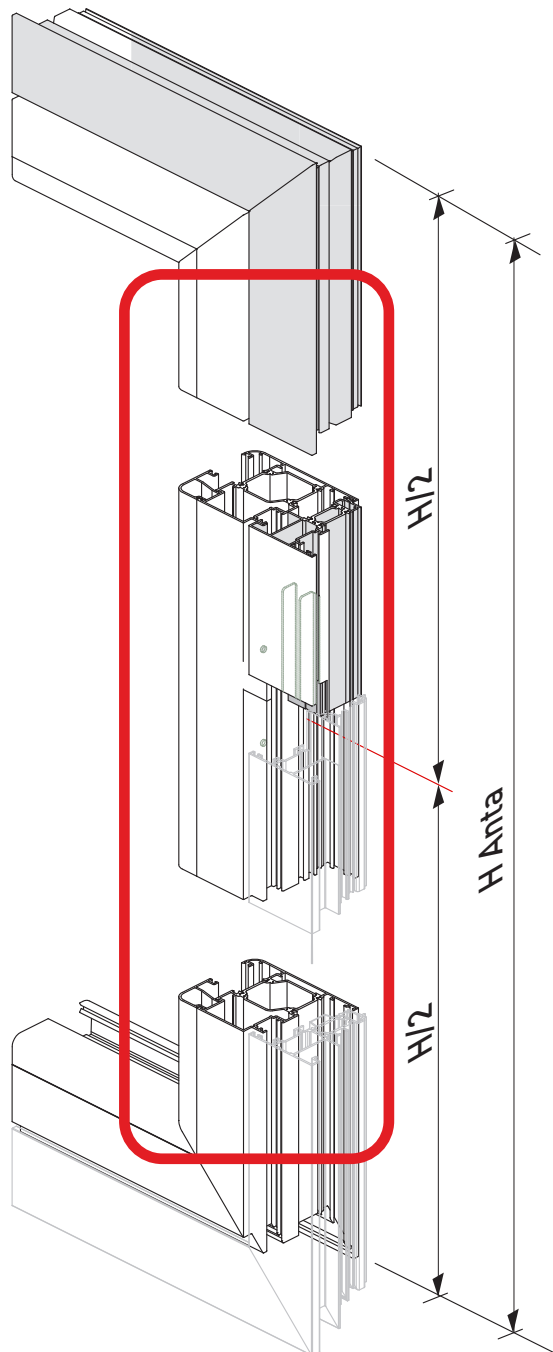
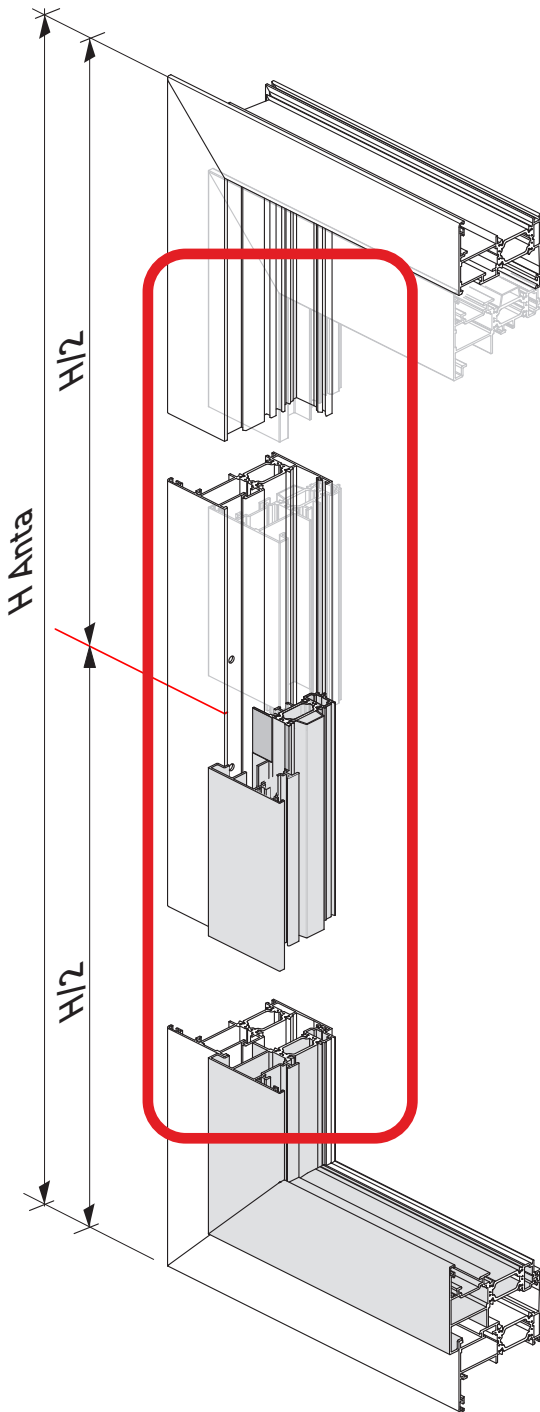
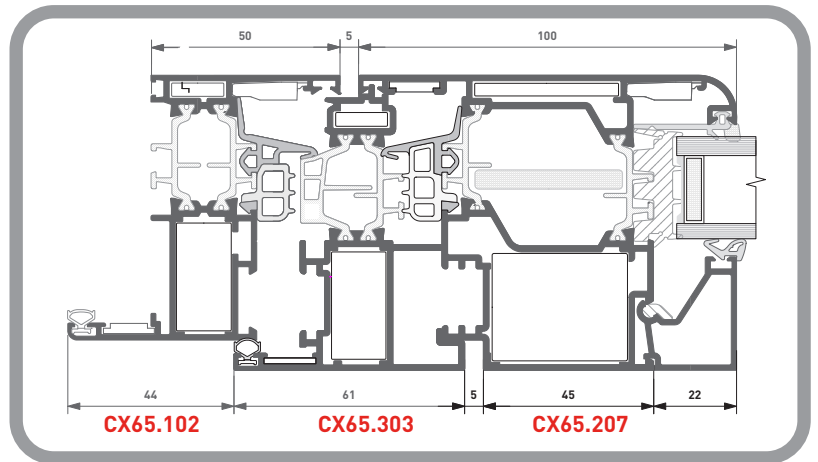



**SOLUZIONE BILICO PIVOT VERSION**

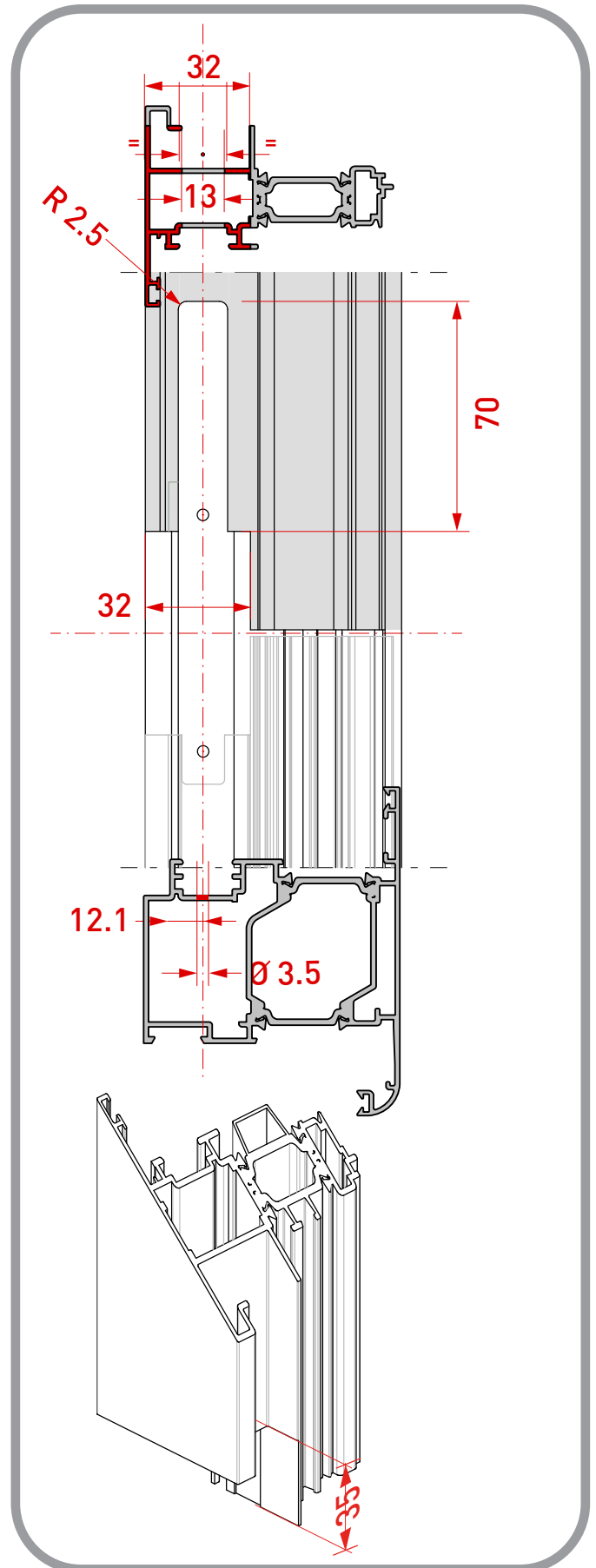
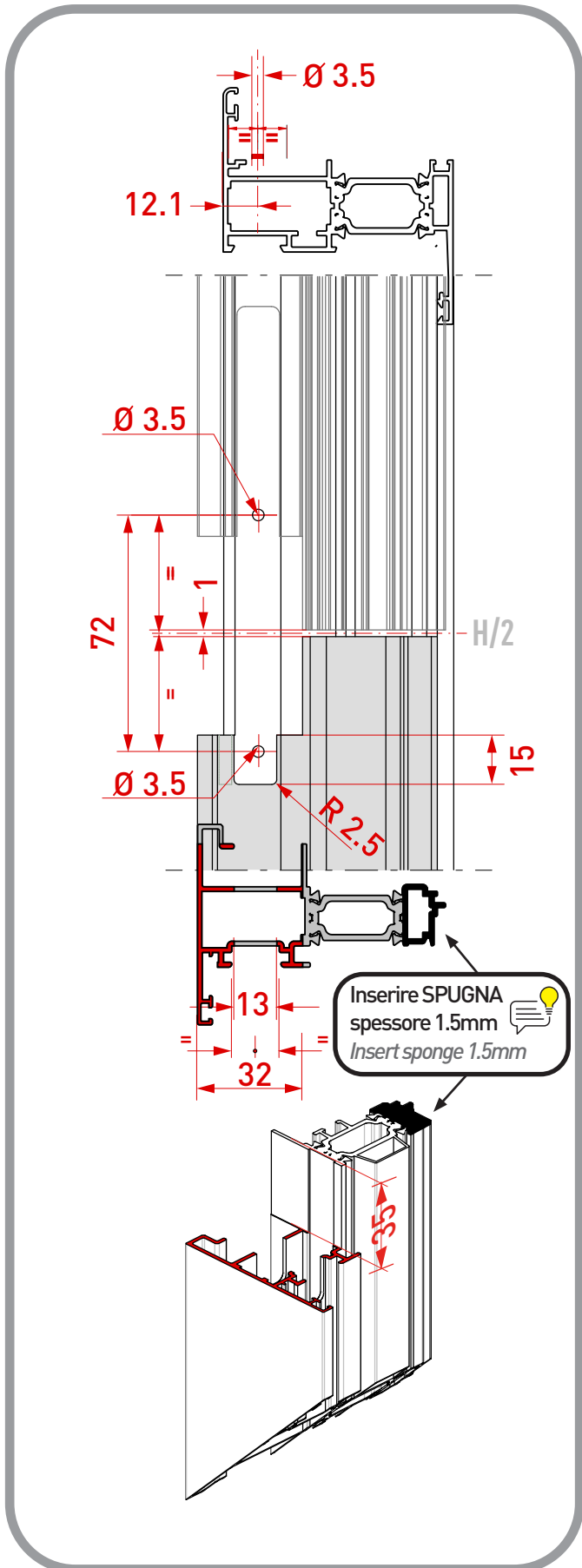

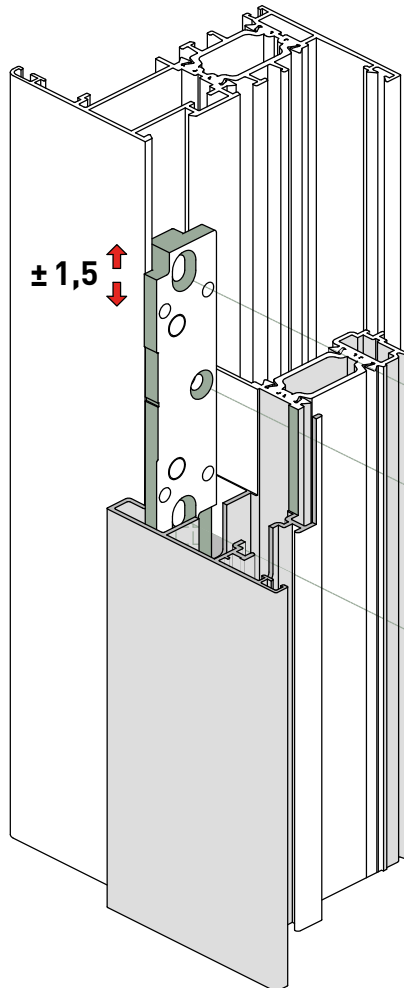

  
Soluzione non utilizzabile con  
profili COMPLANARI  
Solution not applicable with  
coplanar profiles

 **Fissare DOPO la regolazione dell'Anta  
in Altezza**  
Secure AFTER adjusting the Sash height

TSP 4,2 x 25

Spessore 2

TSP 3,9 x 25

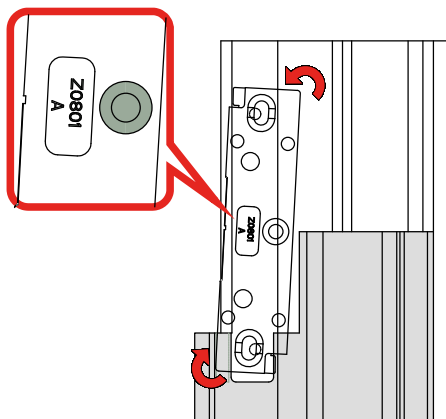
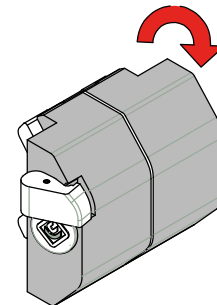

Regolazione in altezza

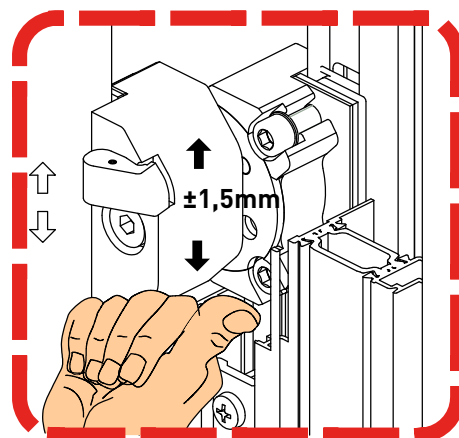



SOLUZIONE BILICO PIVOT VERSION

  
Soluzione non utilizzabile con  
profili COMPLANARI  
Solution not applicable with  
coplanar profiles

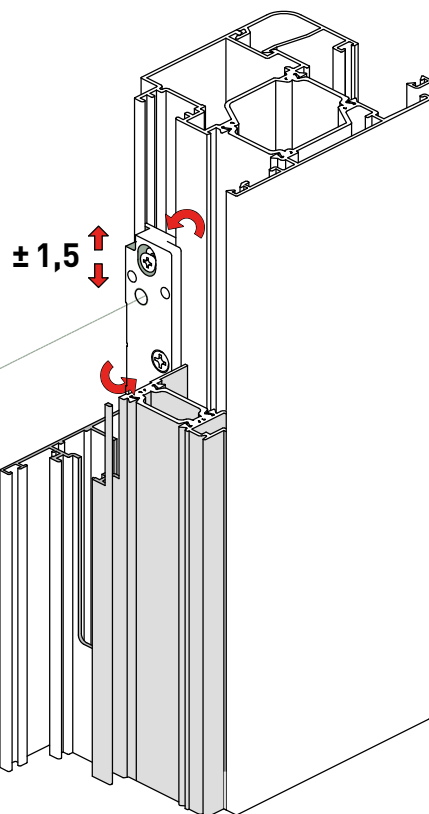
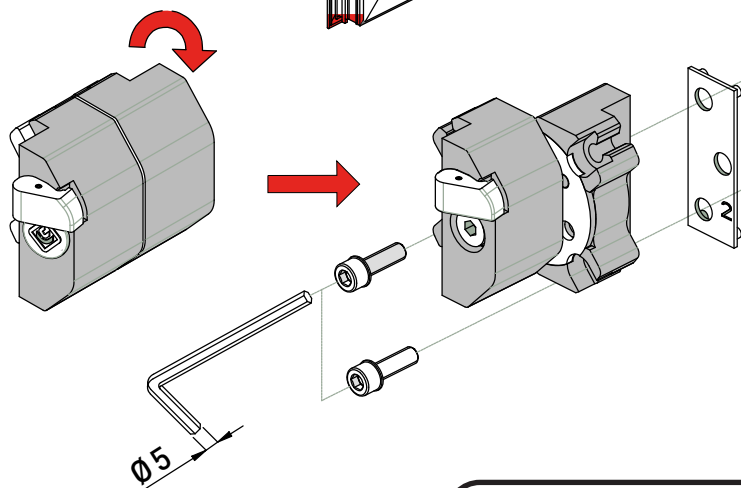
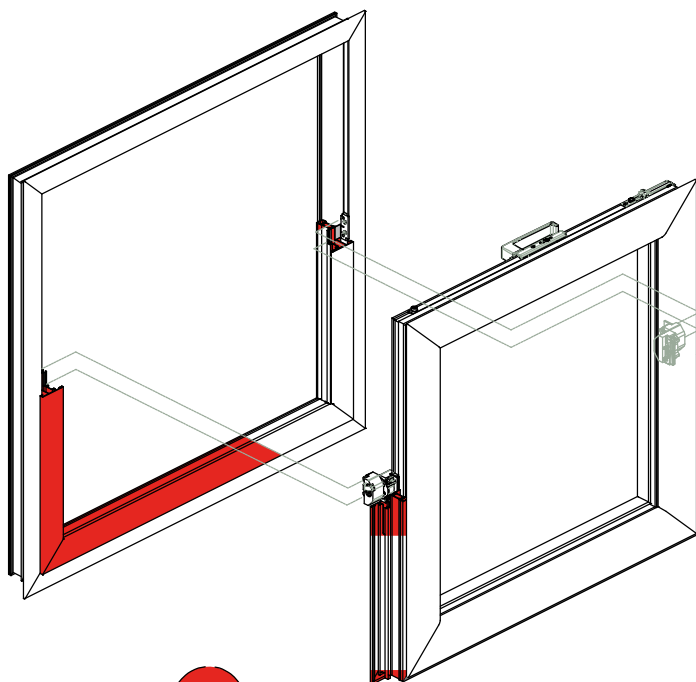

  
Fissare la Cerniera con  
BLOCCO sul lato SINISTRO  
Attach the Hinge with LOCK on  
the LEFT side.

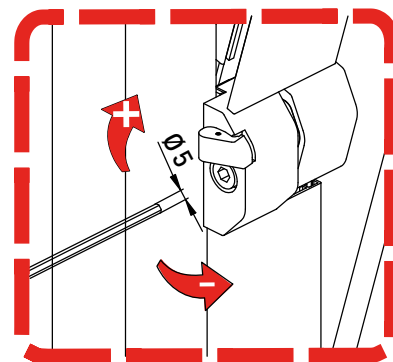
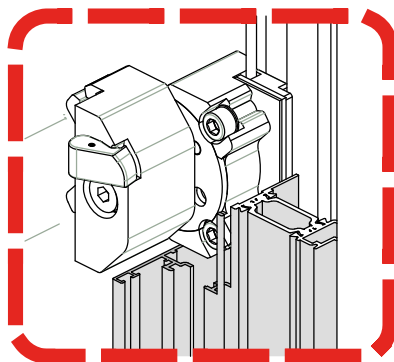
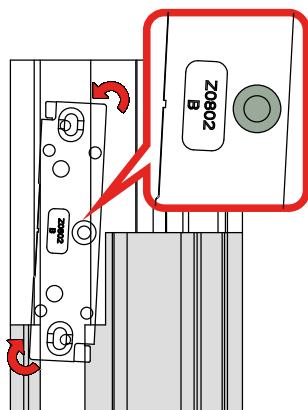



SOLUZIONE BILICO PIVOT VERSION

Horizontal

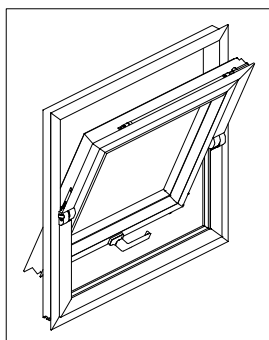

kg 120

Diagramma di carico - Application range

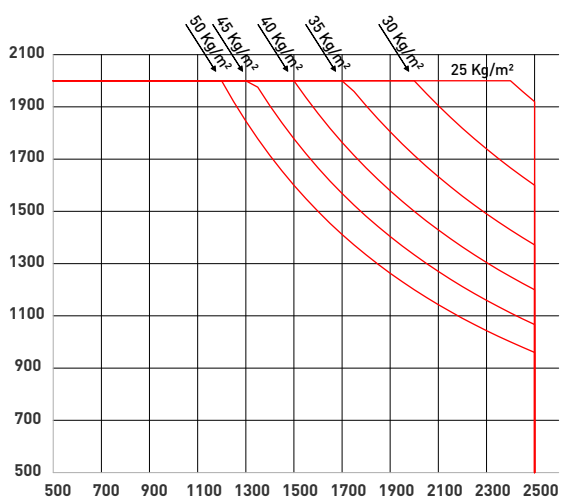

Vertical

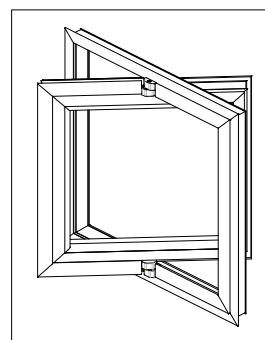

kg 80

Diagramma di carico - Application range

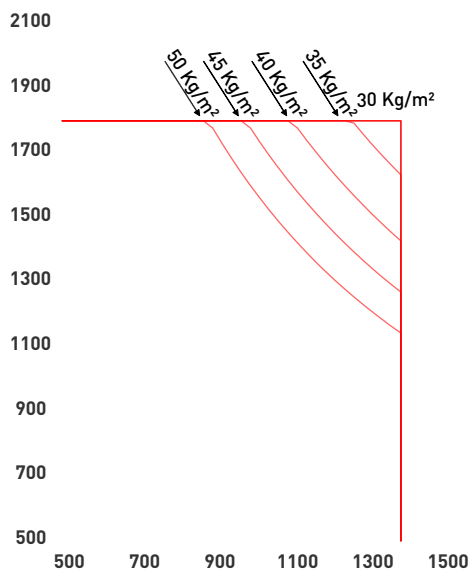

H 2000	A	ARX 03.75	1 cp	A	ARX 03.75	1 cp
	B	ACX 03.77	1 pz	B	ACX 03.77	1 pz
	C	ACX 03.78	1 pz	C	ACX 03.78	1 pz
	D	ACX 03.79	1 pz	D	ACX 03.79	1 pz
	G	ARX 03.80 + ACX 03.81	2 pz	G	ARX 03.80 + ACX 03.81	4 pz
H 1800	A	ARX 03.75	1 cp	A	ARX 03.75	1 cp
	B	ACX 03.77	1 pz	B	ACX 03.77	1 pz
	C	ACX 03.78	1 pz	C	ACX 03.78	1 pz
	D	ACX 03.79	1 pz	D	ACX 03.79	1 pz
H 550	A	ARX 03.75	1 cp	A	ARX 03.75	1 cp
	B	ACX 03.77	1 pz	B	ACX 03.77	1 pz
	C	ACX 03.78	1 pz	C	ACX 03.78	1 pz
						L 2500

H 1800	A	ARX 03.76	1 cp	A	ARX 03.76	1 cp
	B	ACX 03.77	1 pz	B	ACX 03.77	1 pz
	C	ACX 03.78	1 pz	C	ACX 03.78	1 pz
	D	ACX 03.79	1 pz	D	ACX 03.79	1 pz
	G	ARX 03.80 + ACX 03.81	2 pz	G	ARX 03.80 + ACX 03.81	4 pz
H 1000	A	ARX 03.76	1 cp	A	ARX 03.76	1 cp
	B	ACX 03.77	1 pz	B	ACX 03.77	1 pz
	C	ACX 03.78	1 pz	C	ACX 03.78	1 pz
H 550	A	ARX 03.76	1 cp	A	ARX 03.76	1 cp
	B	ACX 03.77	1 pz	B	ACX 03.77	1 pz
						L 1400

**Applicazione Accessori**

**Application of Accessories**

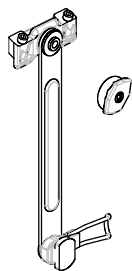

**ACX.02.08**

**Braccio limitatore**  
H Anta= da 260mm a 800mm

*Limiter arm door*  
*H Sash = from 260mm to 800mm*

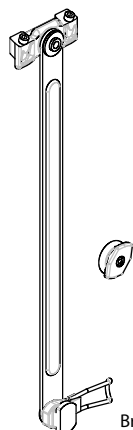

Braccio telescopico a scatto

**ACX.02.07**

**Braccio limitatore**  
H Anta= da 600 mm a 1600 mm

*Limiter arm door*  
*H Sash = from 600 mm to 1600mm*

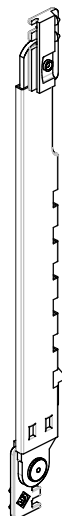

**ACX.02.09**

**Braccio Limitatore a Scatto**

*Snap-on Pair of round / straight double door stop*  
*wing plugs with pre-cutting telescopic arm*

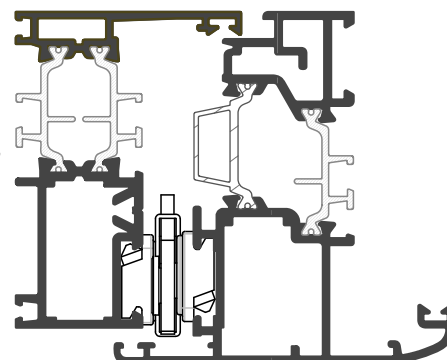
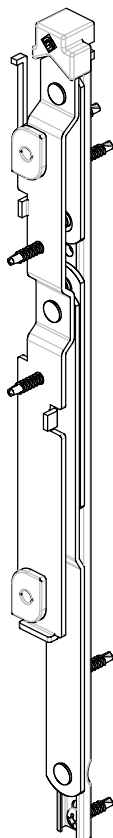
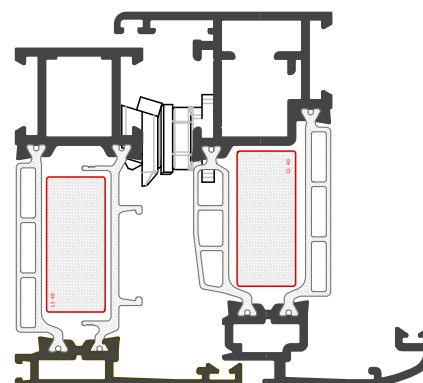

**ACX.02.10**

**Cerniera a Compasso**

*Compass Hinge*

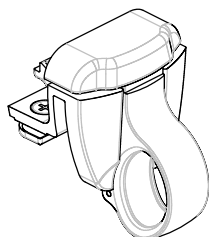
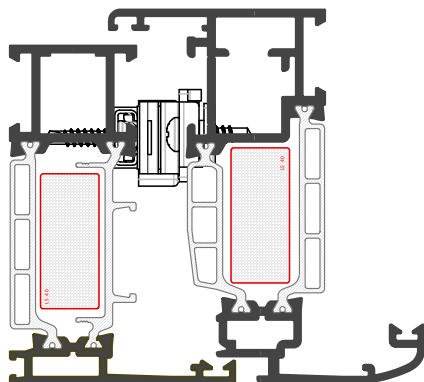

**ACX.03.01**

**Cricchetto ad aggancio con piastrine per telai sormonto**

*Coupling ratchet with plates for overlapping frames*

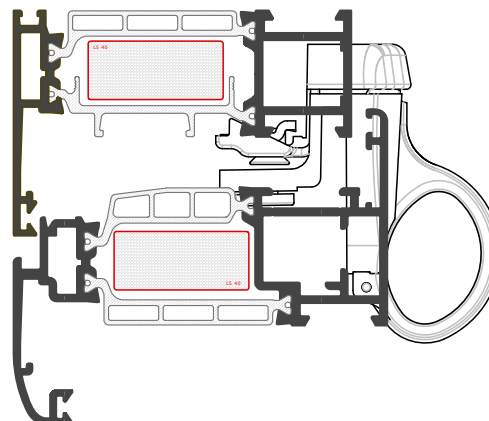



**Applicazione Accessori**

**Application of Accessories**

ARX.03.02  
Maniglia a tavellino  
*Tavellino Handle*

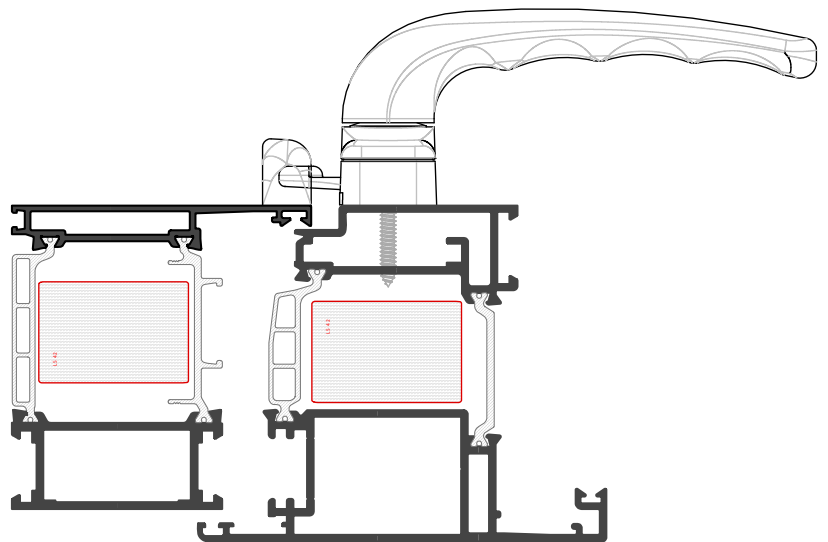
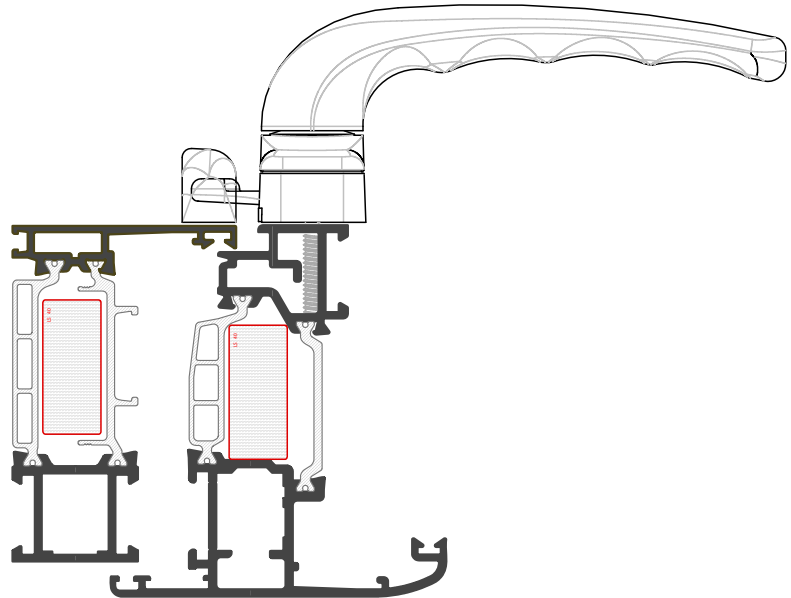
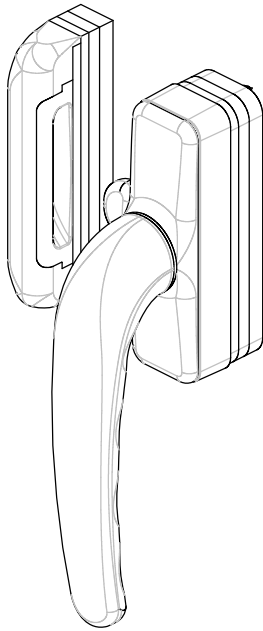

**Applicazione Accessori**

**Application of Accessories**

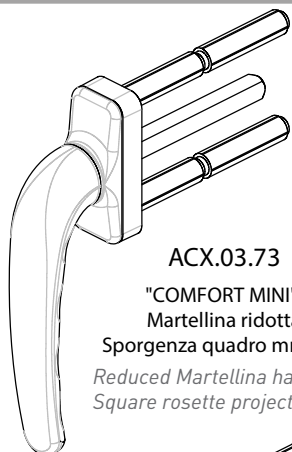

**ACX.03.73**  
"COMFORT MINI"  
Martellina ridotta  
Sporgenza quadro mm.70  
*Reduced Martellina handle  
Square rosette projection mm.70*

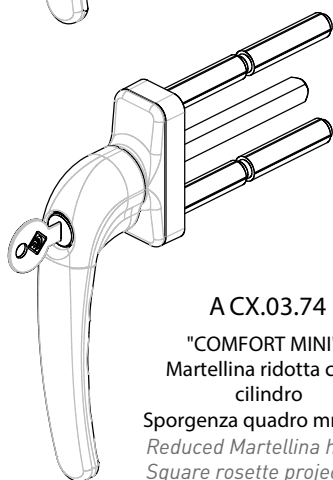

**ACX.03.74**  
"COMFORT MINI"  
Martellina ridotta con  
cilindro  
Sporgenza quadro mm.70  
*Reduced Martellina handle  
Square rosette projection mm.70*

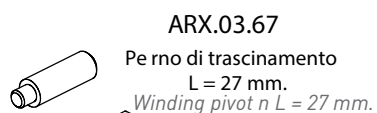

**ARX.03.67**  
Perno di trascinamento  
L = 27 mm.  
*Winding pivot n L = 27 mm.*

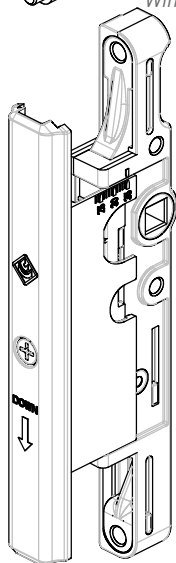

**ACX.03.72**  
Movimentazione Bidirezionale  
Interasse 23 - 35 mm.  
*Bi-directional movement Center  
Distance 23 - 35 mm.*

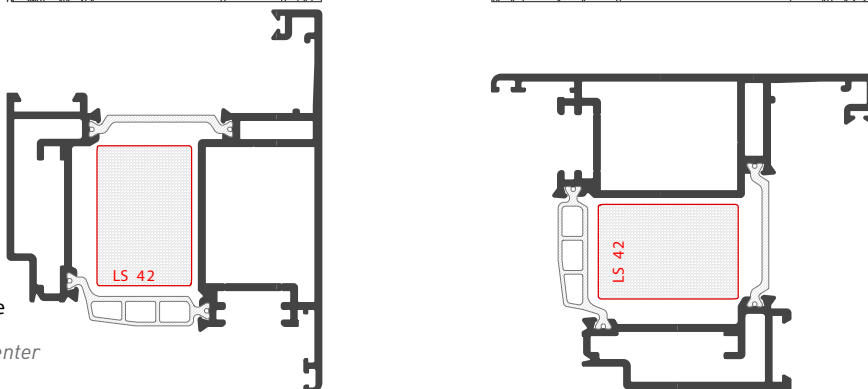
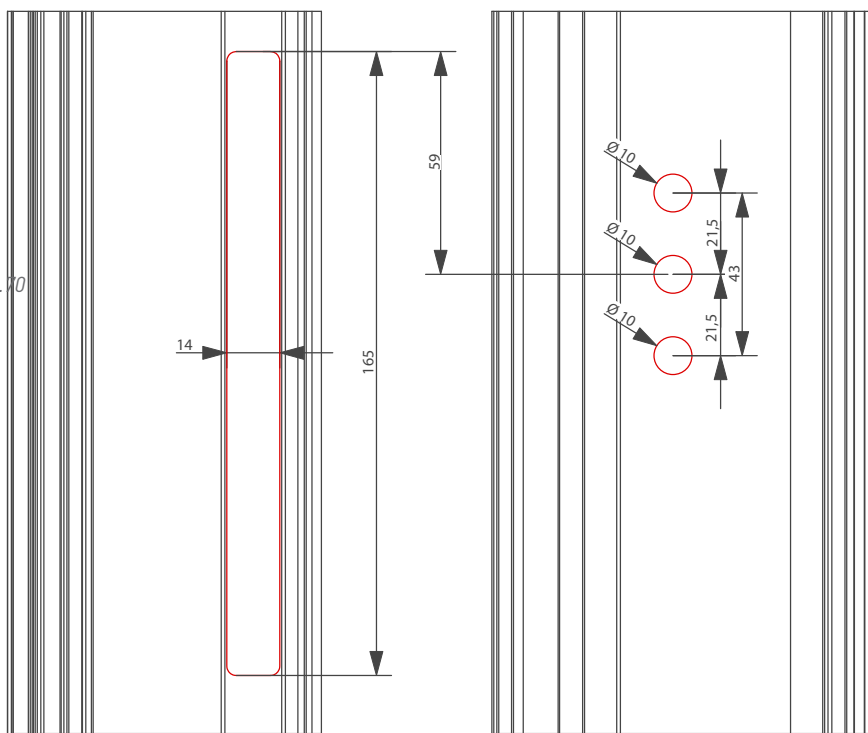
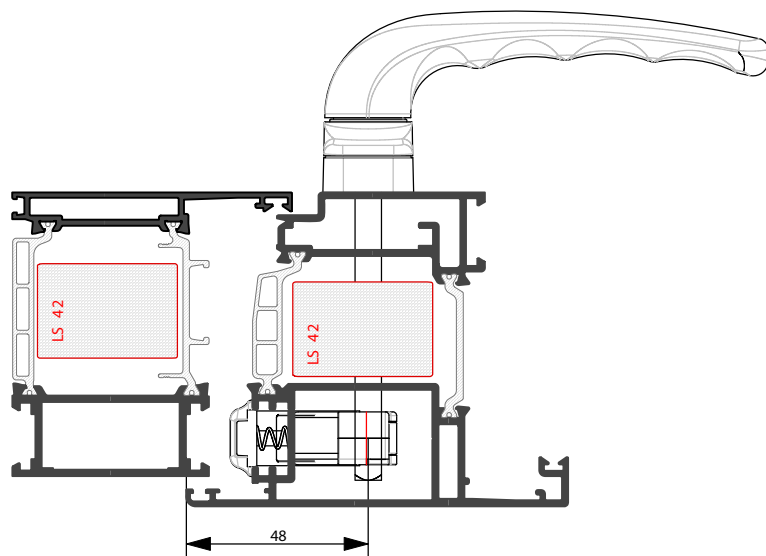

**Applicazione Accessori**

**Application of Accessories**

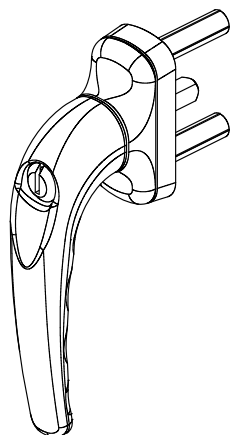
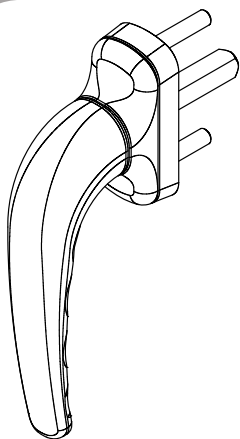

**ARX.03.04**

Martellina

Sporgenza quadro mm.24

*Martellina Handle Square  
Rosette projection mm.24*

**ARX.03.05**

Martellina con chiave

Sporgenza quadro mm.24

*Martellina Handle with key  
square rosette projection  
mm.24*

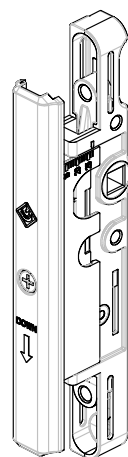

**ACX.03.66**  
Perno 11 mm.

**ARX.03.09**

Movimentazione bidirezionale  
regolabile 15 - 27 mm.

*Adjustable bidirectional  
movement 15 - 27 mm.*

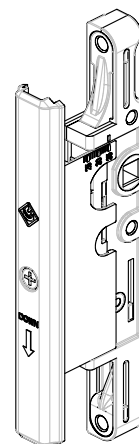

**ACX.03.67**  
Perno 27 mm.

**ACX.03.72**

Movimentazione bidirezionale  
regolabile 23 - 35 mm.

*Adjustable bidirectional  
movement 23 - 35 mm.*

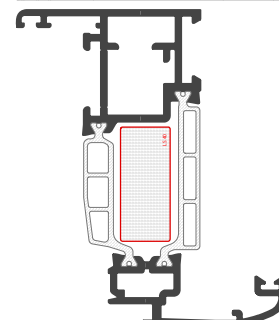
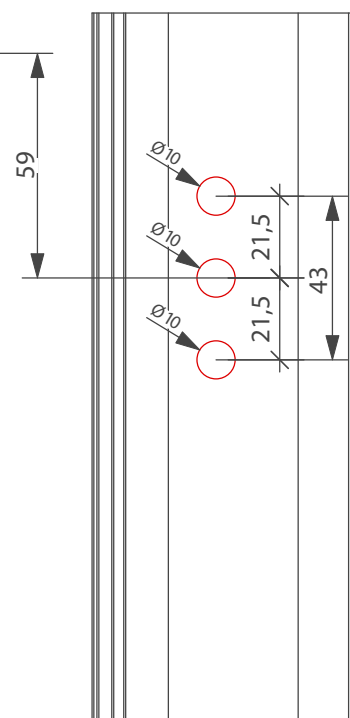
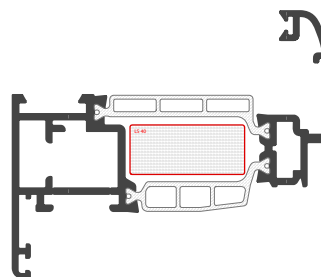
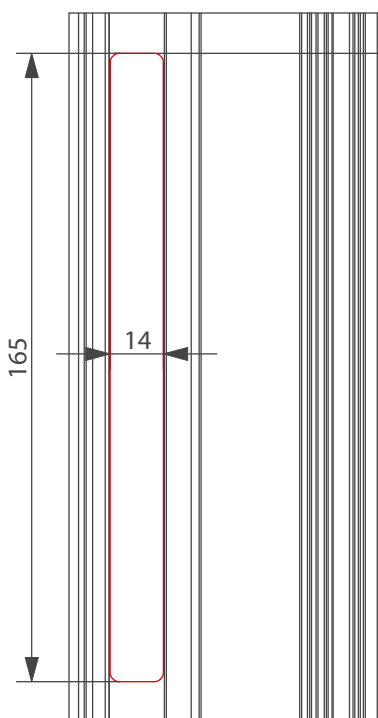
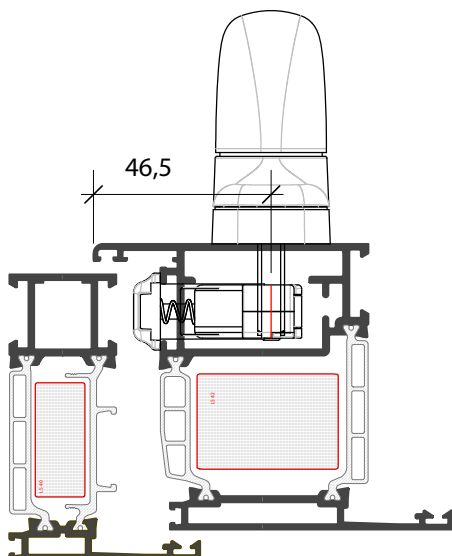
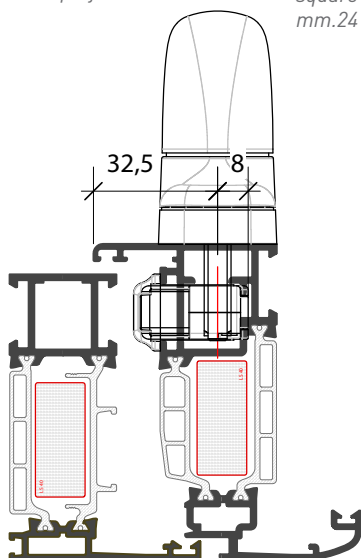

**Applicazione Accessori**

**Application of Accessories**

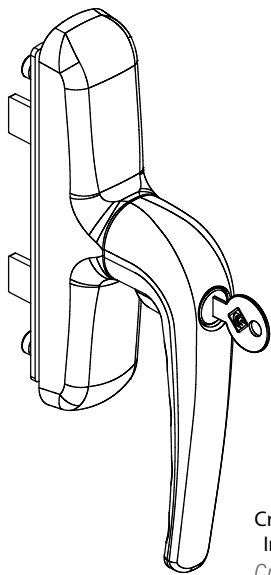

**ARX.03.07**

Cremonese con chiave  
Interasse 84.5 - 92 - 104  
Cremonese bolt opening external -  
int. 28/65mm

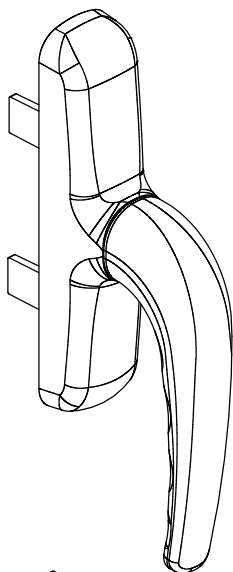
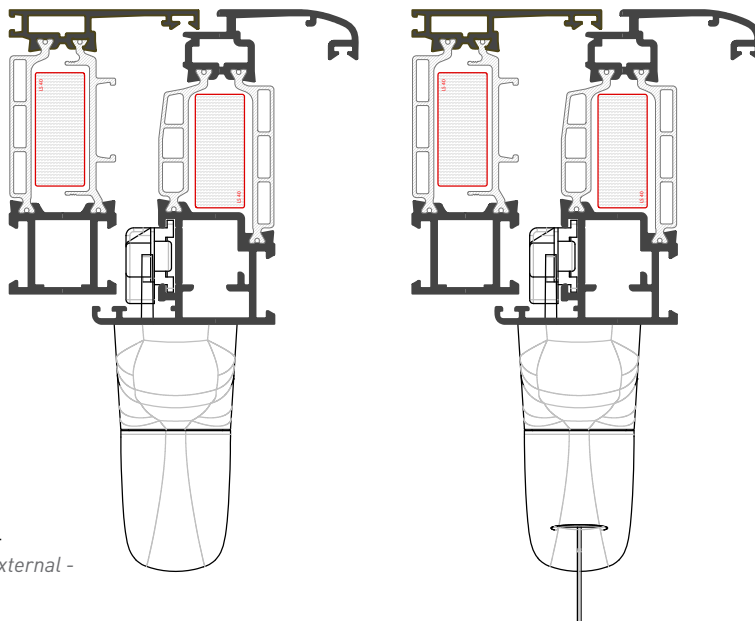

**ARX.03.06**

Cremonese  
Interasse 84.5 - 92 - 104  
Cremonese bolt with cylinder lock  
external opening - int. 38/65mm

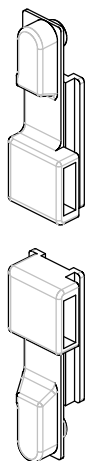
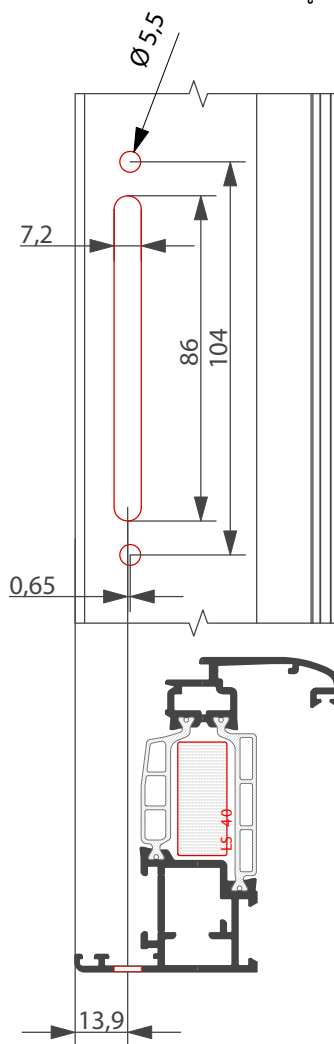

**ACX.03.17**

Innesti cremonese  
Winding pivot L=27mm

**Applicazione Accessori**

**Application of Accessories**

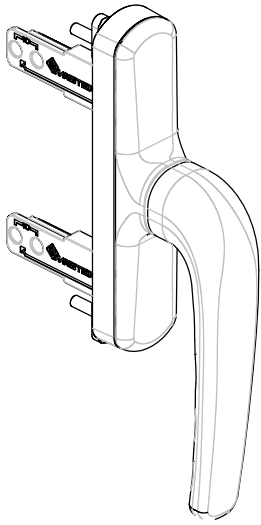

**ARX.03.47**

Cremonese apertura  
esterna - int. 28/65mm  
*Cremonese bolt external opening -  
int. 28/65mm*

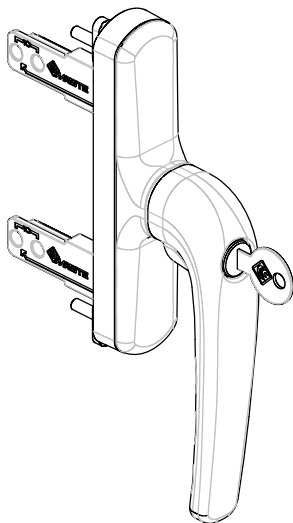
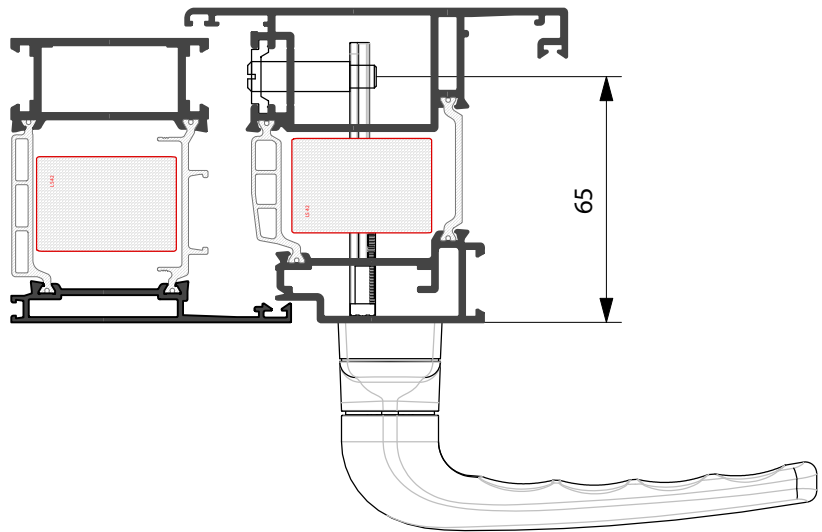

**ARX.03.48**

Cremonese apertura esterna  
con chiave - int. 38/65mm  
*Cremonese bolt external opening  
with cylinder lock - int. 38/65mm*

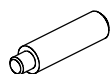
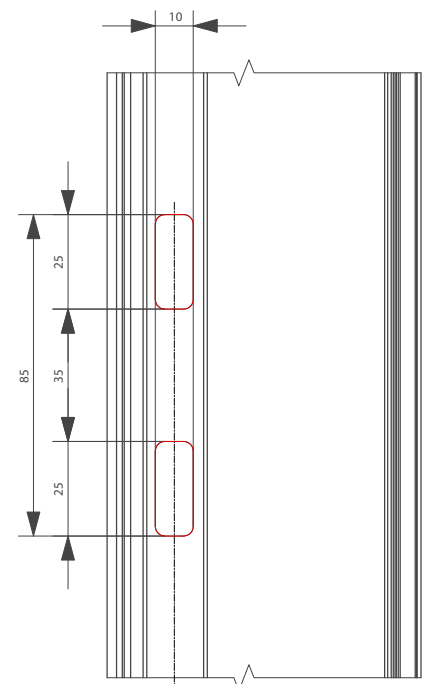
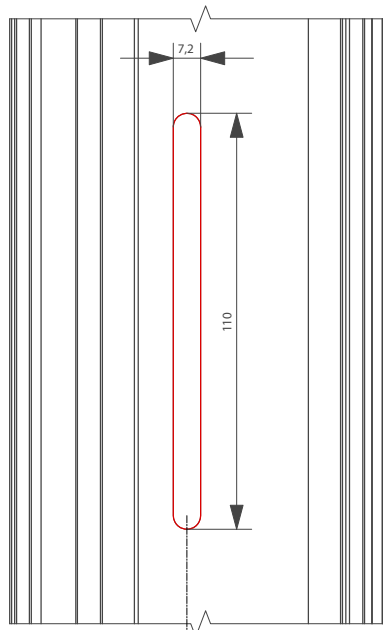

**ACX.03.67**

Perno di trascinamento  
L=27mm  
*Winding pivot L=22mm*

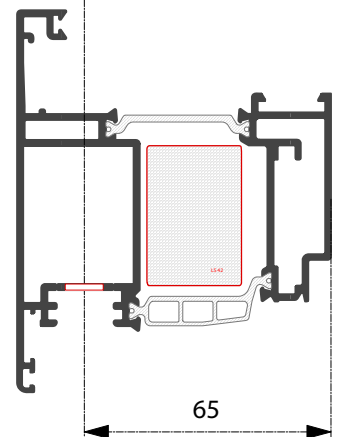
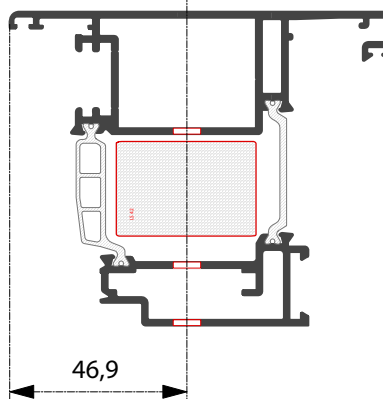

**Applicazione Accessori**

**Application of Accessories**

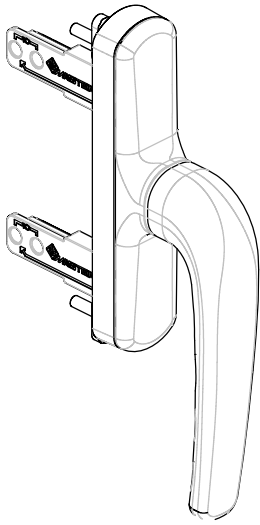

**ARX.03.47**

Cremonese apertura  
esterna - int. 28/65mm  
*Cremonese bolt external opening -  
int. 28/65mm*

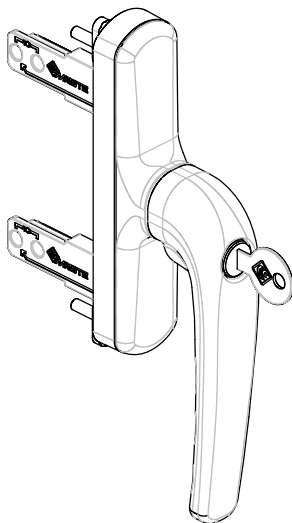
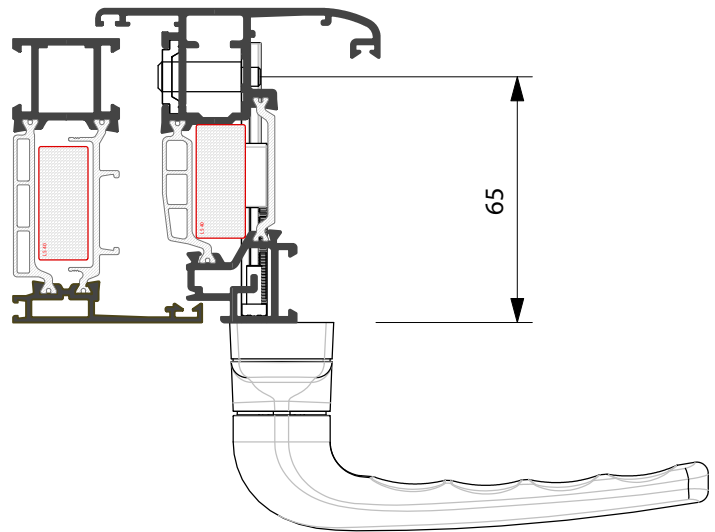

**ARX.03.48**

Cremonese apertura esterna  
con chiave - int. 38/65mm  
*Cremonese bolt external opening  
with cylinder lock - int. 38/65mm*

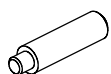
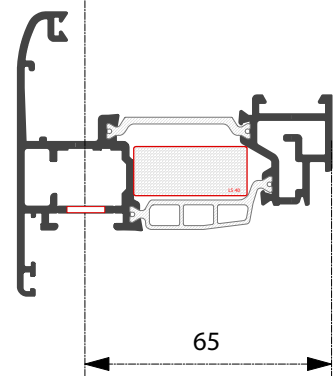
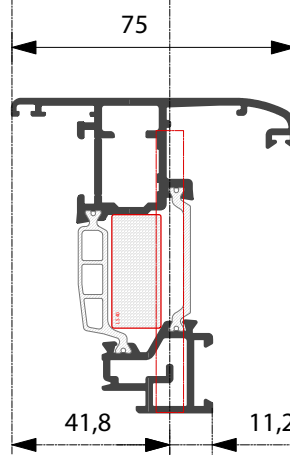
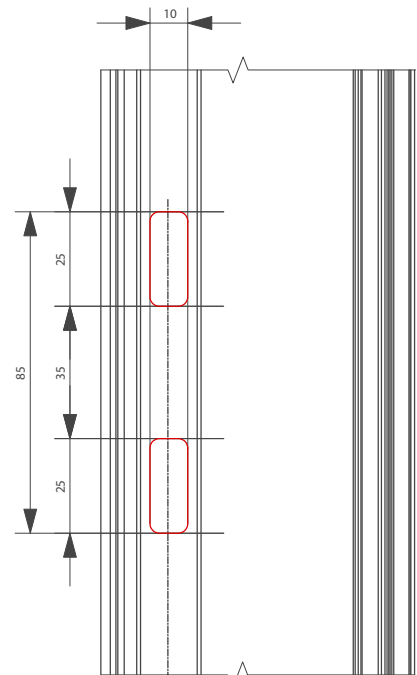
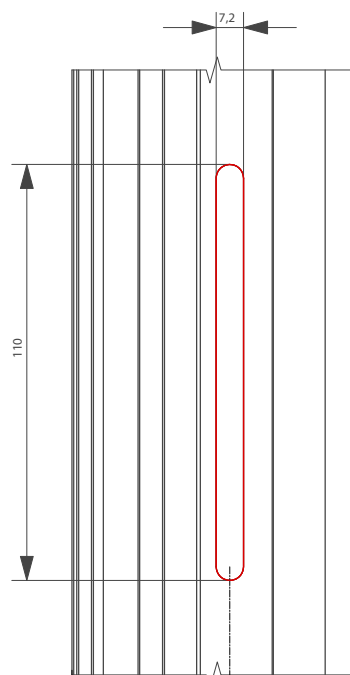

**ARX.03.45**

Perno di trascinamento  
L=22mm  
*Winding pivot L=22mm*

**Applicazione Accessori**

**Application of Accessories**

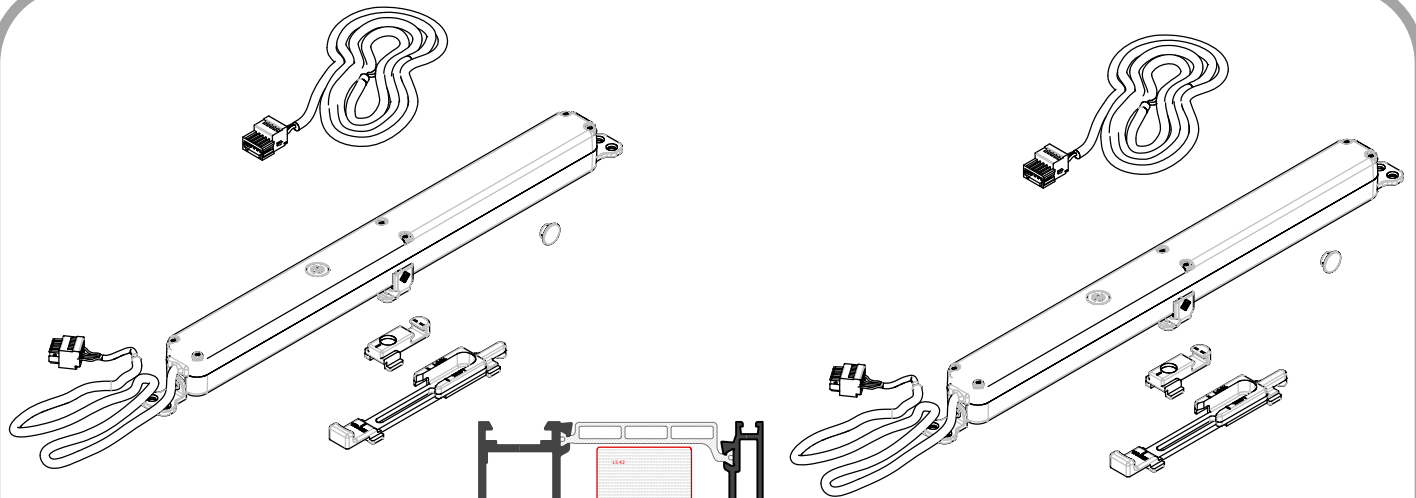

**ACX.20.01**

"WiCloud Rc" Attuatore a catena ad  
incasso radiocomandato  
"WiCloud Rc" Remote Controlled  
Recessed Chain Actuator

**ACX.20.03**

"WiCloud Rc" Attuatore a catena ad  
incasso  
"WiCloud Rc" Recessed chain  
actuator

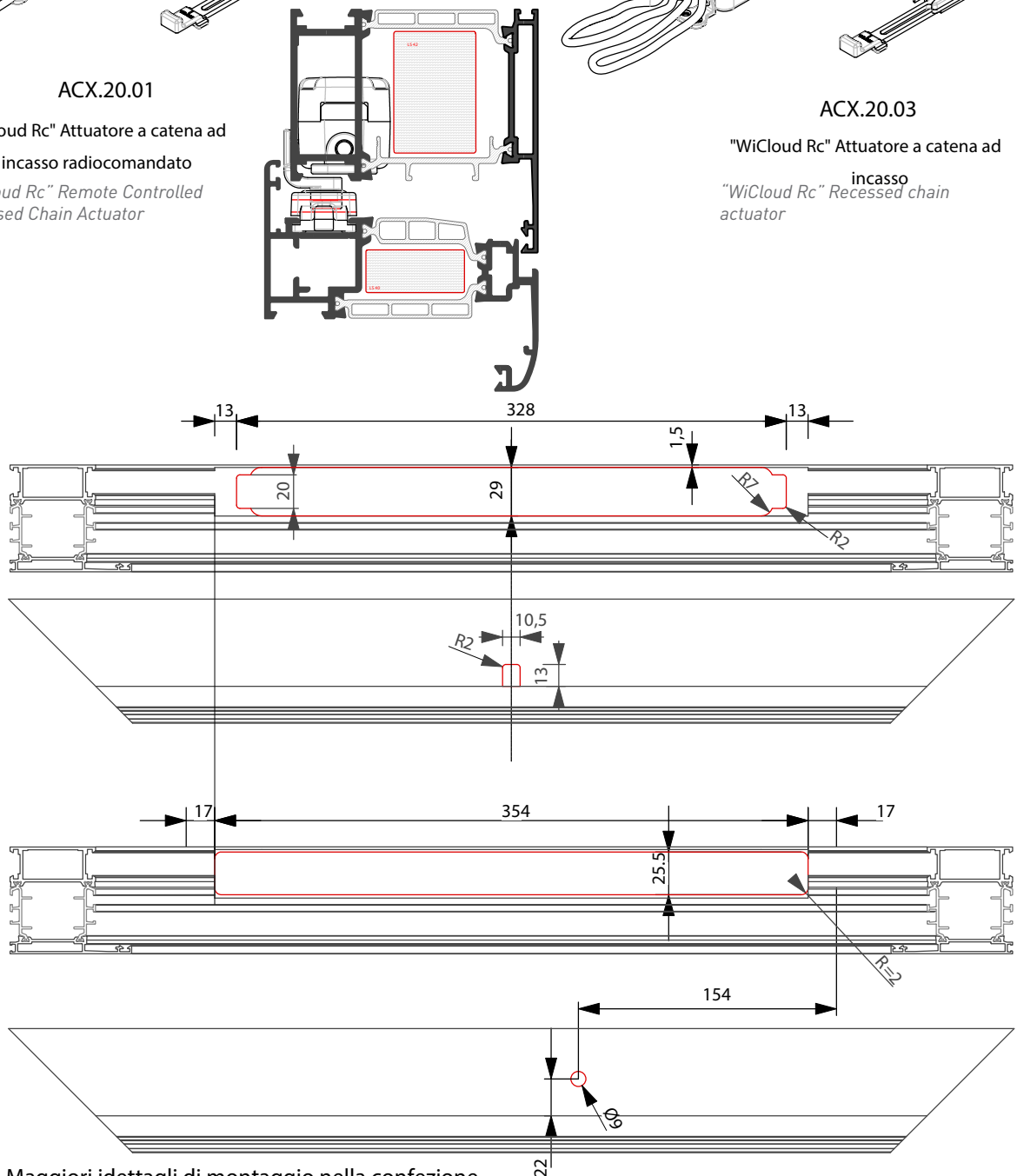

**NB . Maggiori idettagli di montaggio nella confezione**  
N.B. More details about assembly in the package

Applicazione Accessori

Application of Accessories

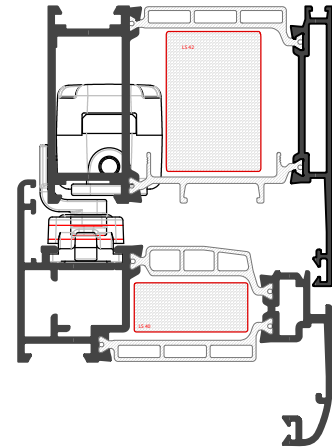
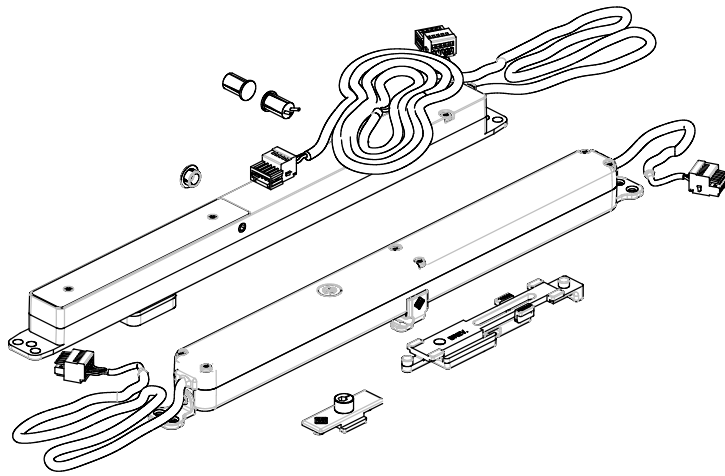

ACX.20.04

"WiCloud Rc - Lock"

Attuatore a catena radiocomandato + serratura elettromeccanica

"WiCloud Rc - Lock"

Remote controlled chain actuator + electromechanical lock

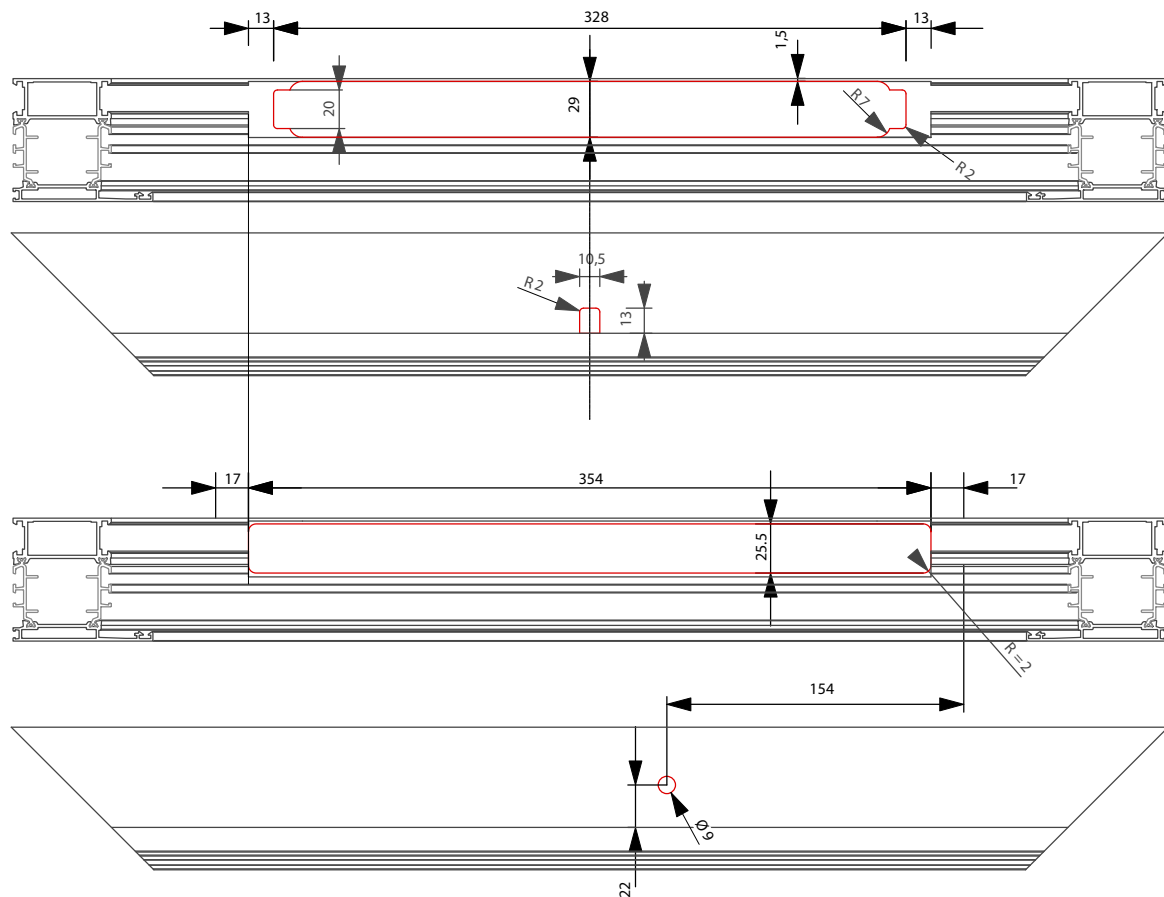

NB . Maggiori idettagli di montaggio nella confezione



**GRUPPI FRESE**  
**MILLING UNITS**

**GRFW 34 CAS3553**

Gruppo Frese CX550/650/750  
Traversi/telaio-ante e FN  
*Crosspiece/door frame milling unit TAPE HW*

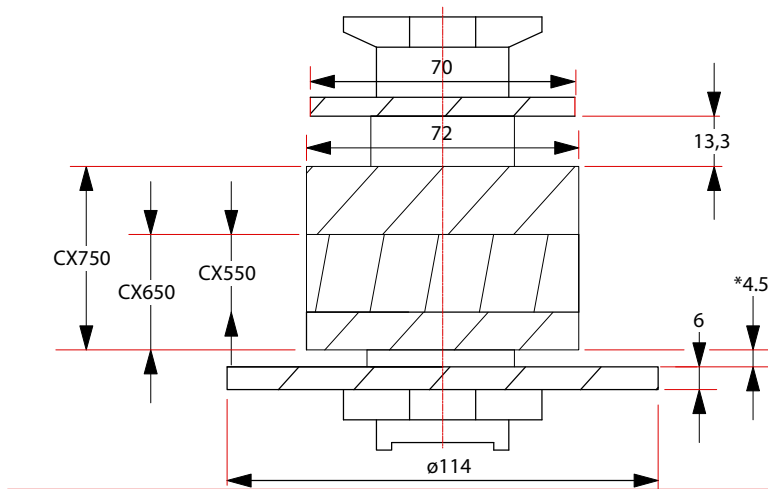
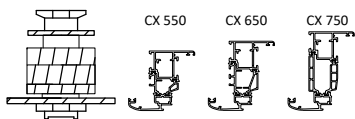

**GRFW 35 CAS3553**

Gruppo Frese CX550/650/750  
Traversi ante Magg  
*Crosspiece frame milling unit Major Sashes*

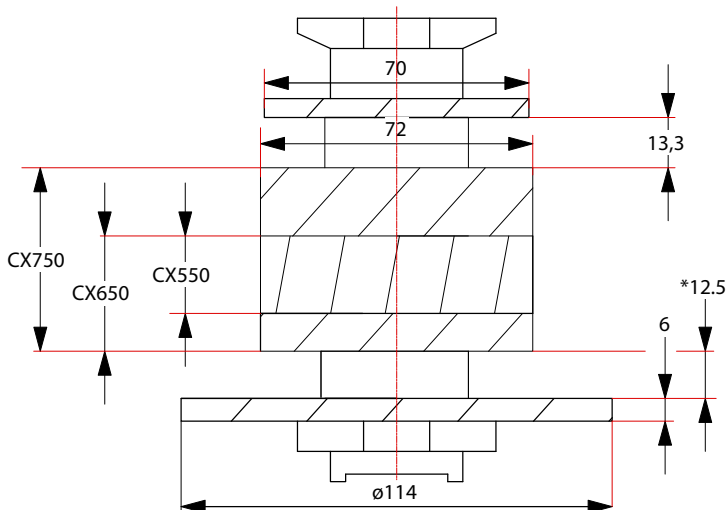
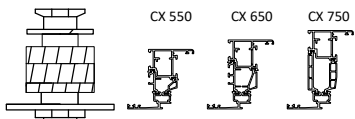

**GRFW 36 CAS3553**

Gruppo Frese CX550/650/750  
Traversi/ante AE  
*Crosspiece/door frame milling unit for EUROPEAN CHAMBER*

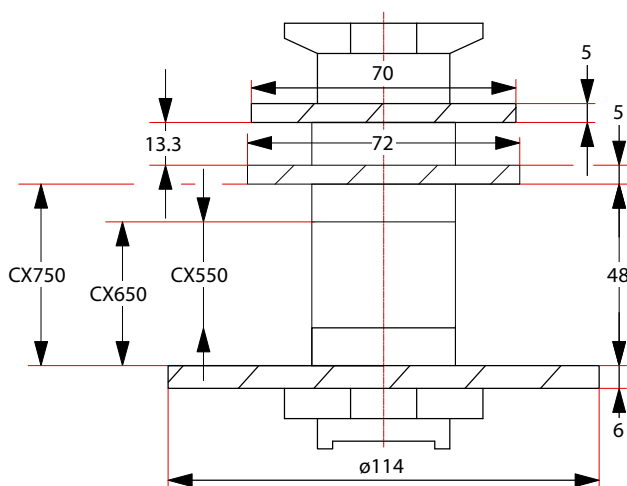
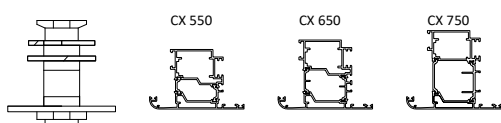

**GRUPPI FRESE**



**GRFW 37 CAS3553**

Gruppo Frese CX750  
Telaio/Soglia

Frame / THRESHOLD milling unit

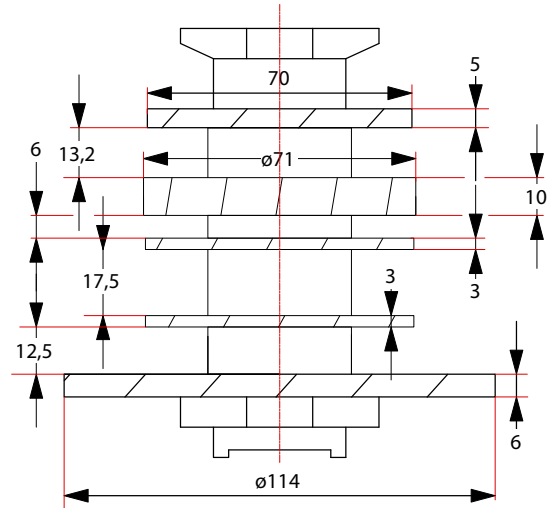
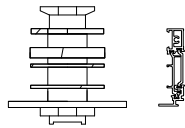



**Applicazione Accessori**

**Application of Accessories**

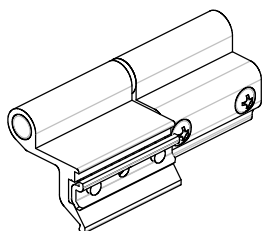

**ACX.02.01**

Cerniera a montaggio rapido a 2 ali  
*Rapid assembly 2-leafed hinge*

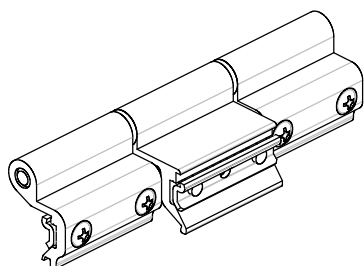

**ACX.02.03**

Cerniera a montaggio rapido a 3 ali  
*Rapid assembly 3-leafed hinge*

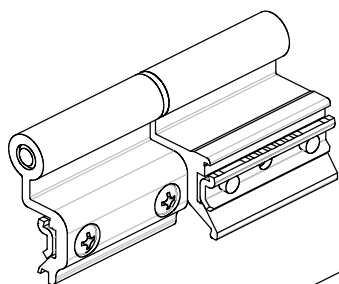
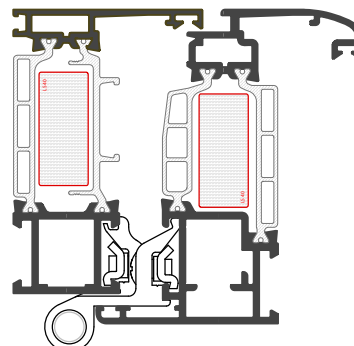

**ACX.02.02**

Cerniera a montaggio rapido a 2 ali  
*Rapid assembly 2-leafed hinge*

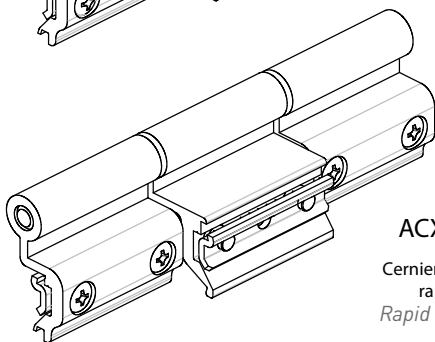

**ACX.02.04**

Cerniera a montaggio rapido a 3 ali  
*Rapid assembly 3-leafed hinge*

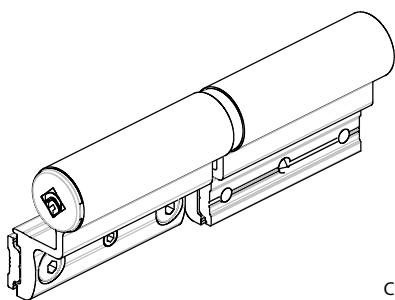
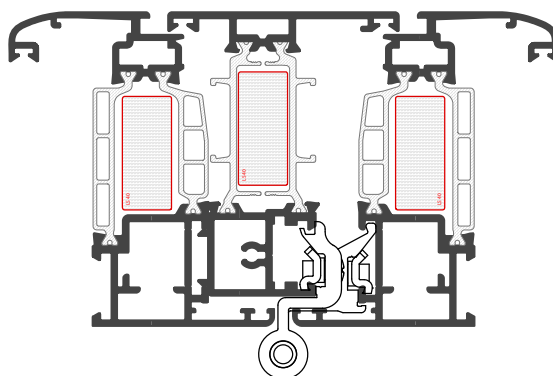

**ACX.02.11**

Cerniera porte a 2 ali  
*Rapid assembly 2-leafed hinge*

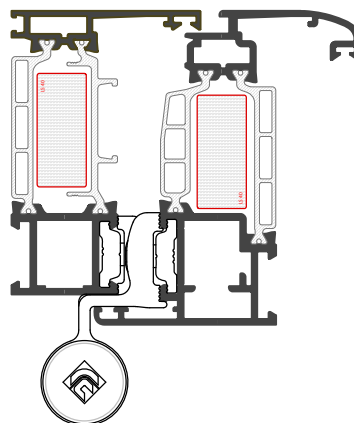

**Applicazione Accessori**

**Application of Accessories**

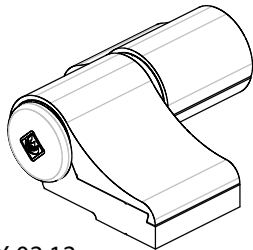
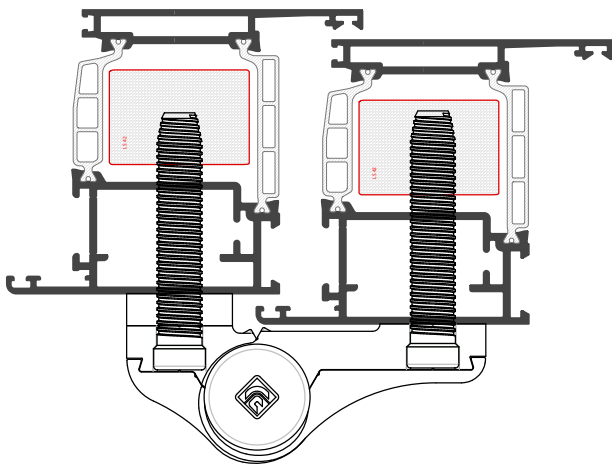

ARX.02.12

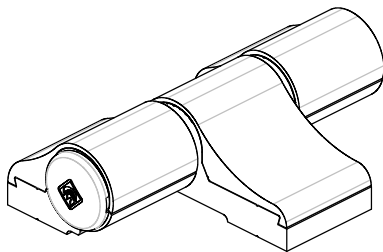

ARX.02.13

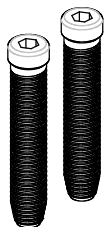

ARX.02.23

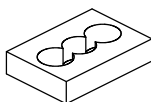

ARX.02.25

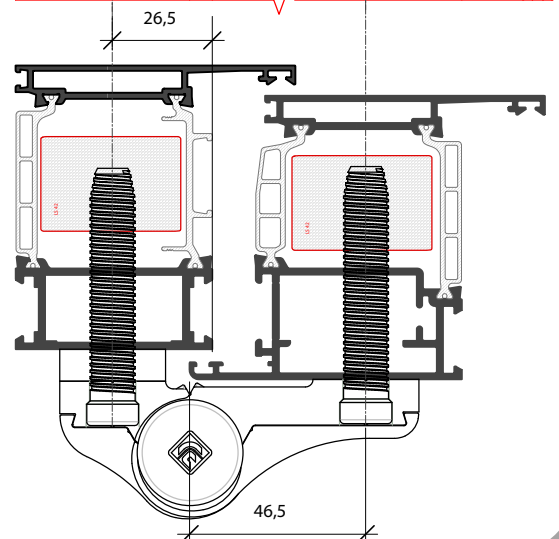
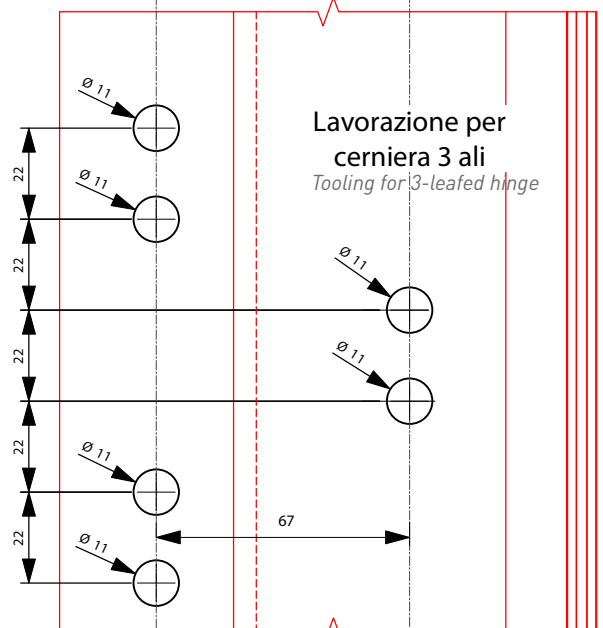
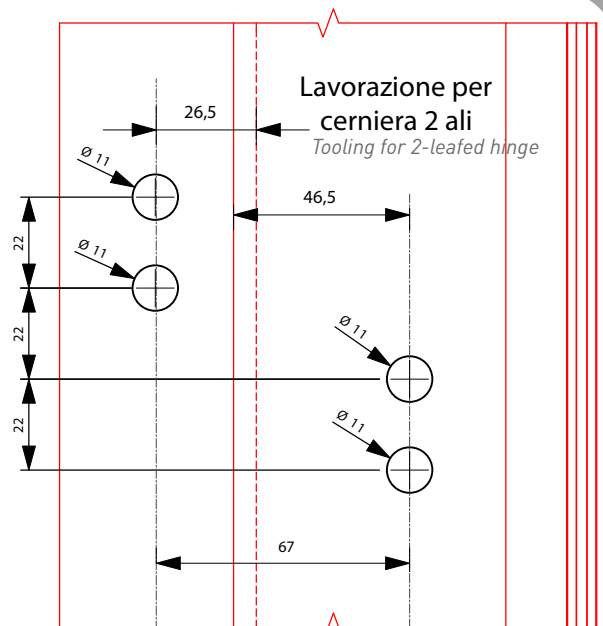

**Applicazione Accessori**

**Application of Accessories**

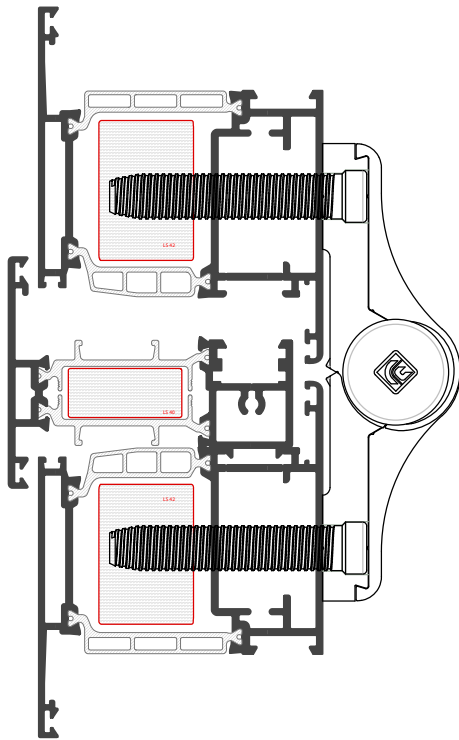

ARX.02.33

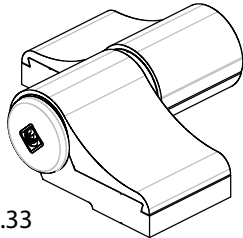

ARX.02.34

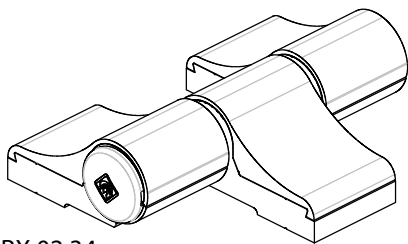

ARX.02.23

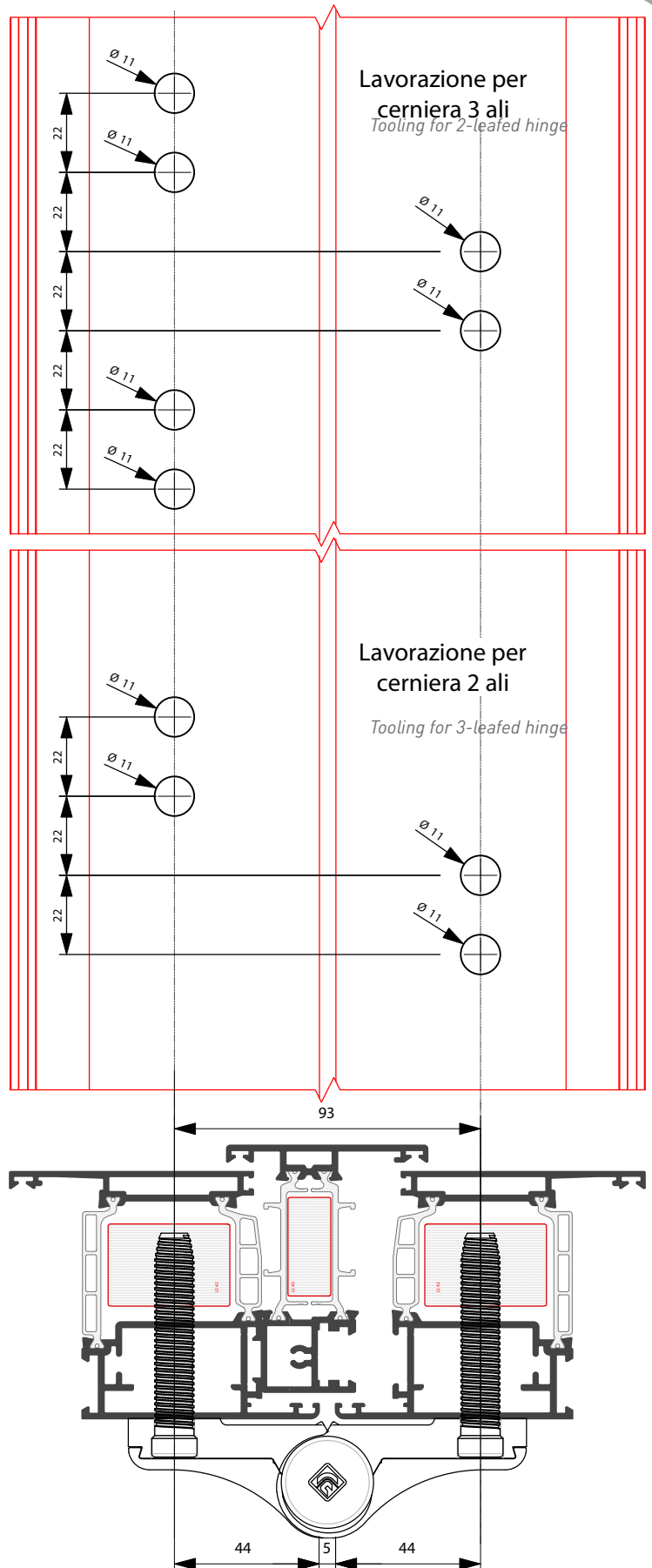
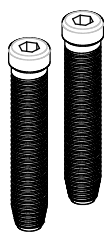

**Applicazione Accessori**

**Application of Accessories**

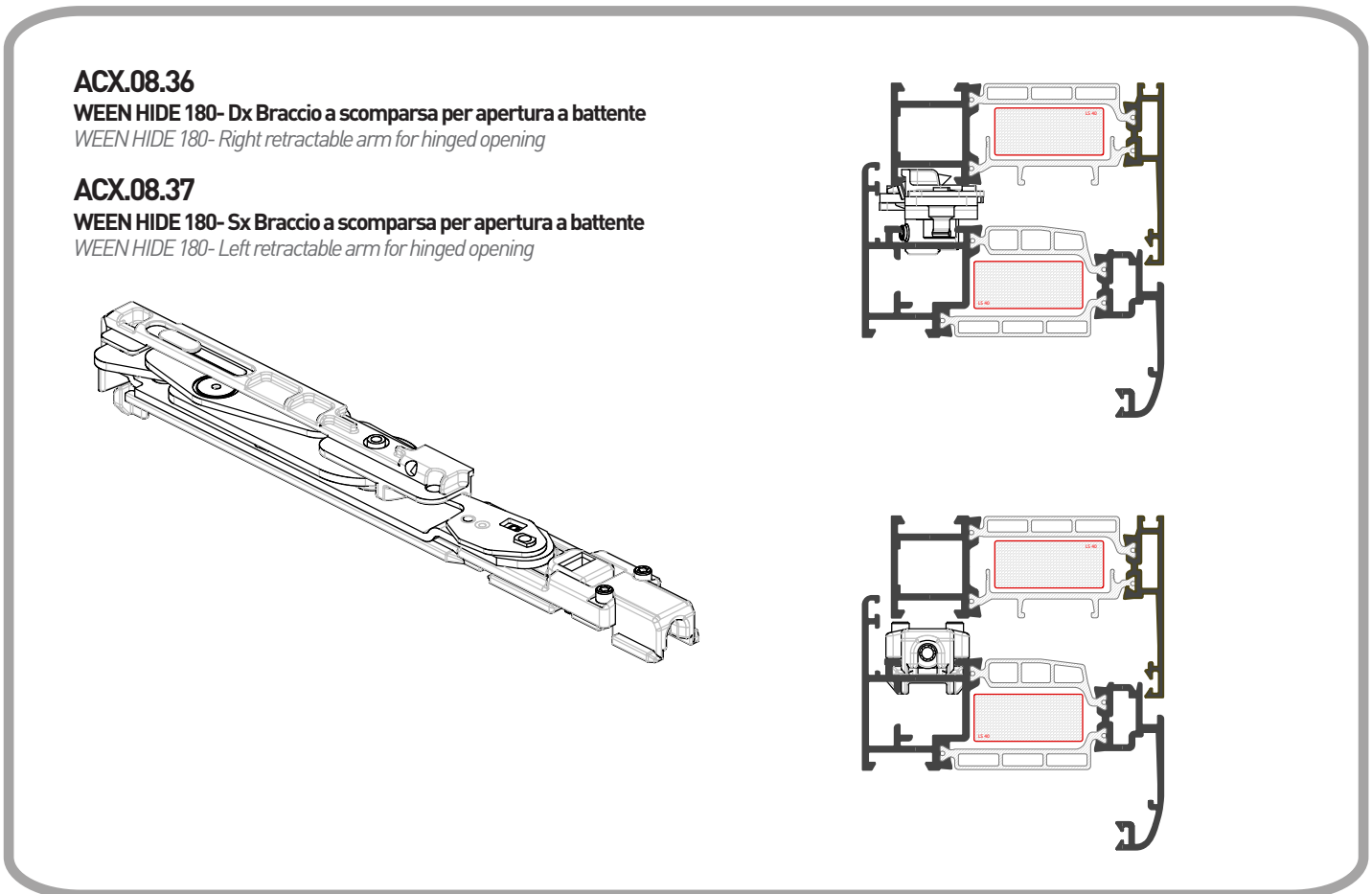
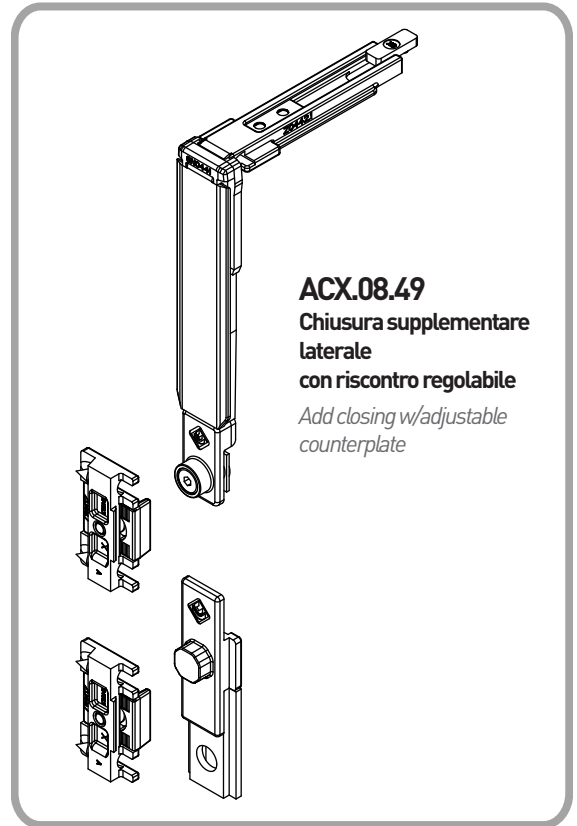
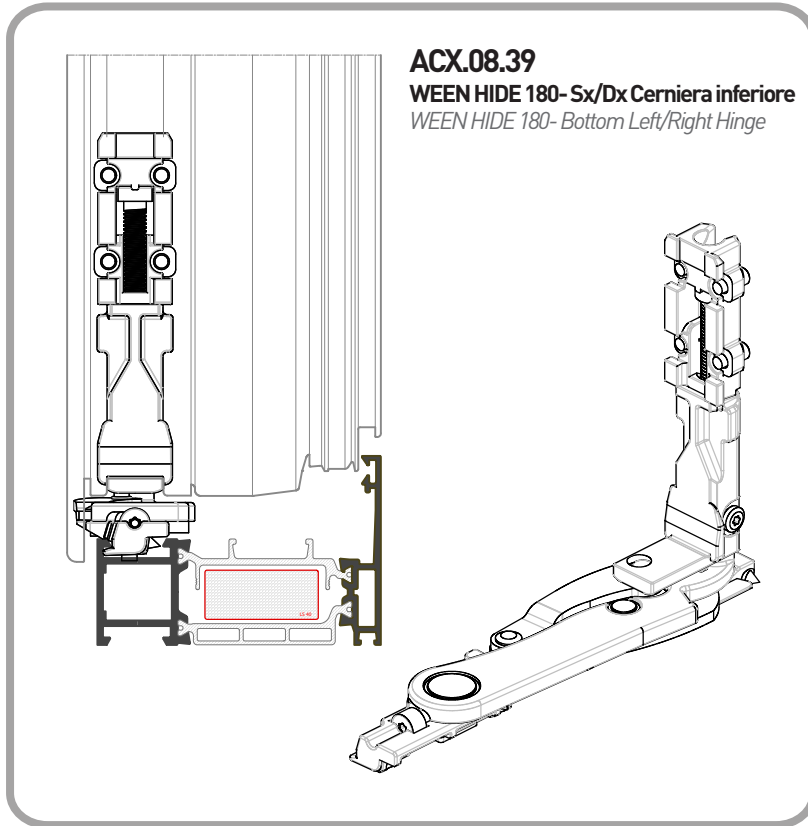

**Applicazione Accessori**

**Application of Accessories**

**ACX.08.40**

**Ween hide 180**

**kit base anta ribalta con anti falsa manovra sulla  
cremonese ante CX70.260 e CX70.261**

*tilt&turn window base kit with wrong counter-actuation on the  
Cremonese bolt*

**RIBALTA**  
**Folding**

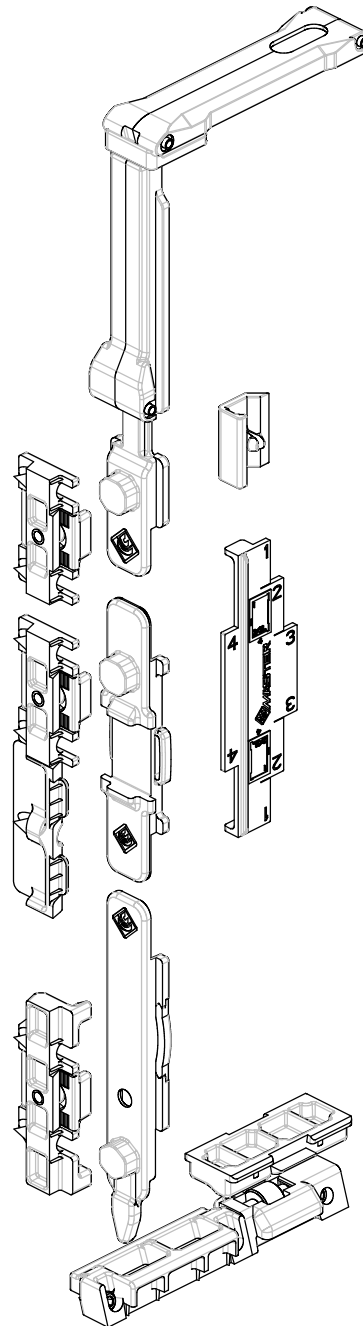
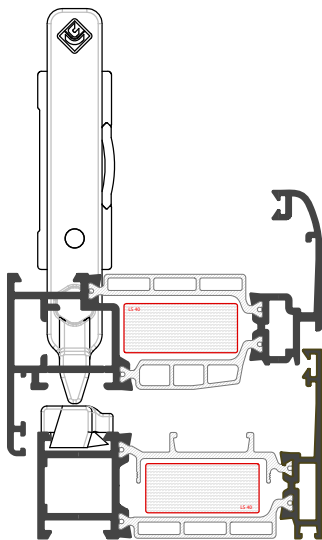
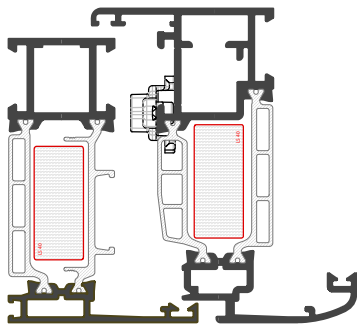
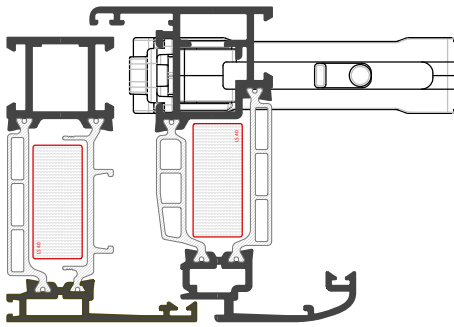

**Applicazione Accessori**

**Application of Accessories**

**ACX.08.41**  
**Ween hide 180**  
**kit base anta ribalta con anti falsa manovra sulla**  
**cremonese**

*tilt&turn window base kit with wrong counter-actuation on the Cremonese bolt*

**RIBALTA**  
**Folding**

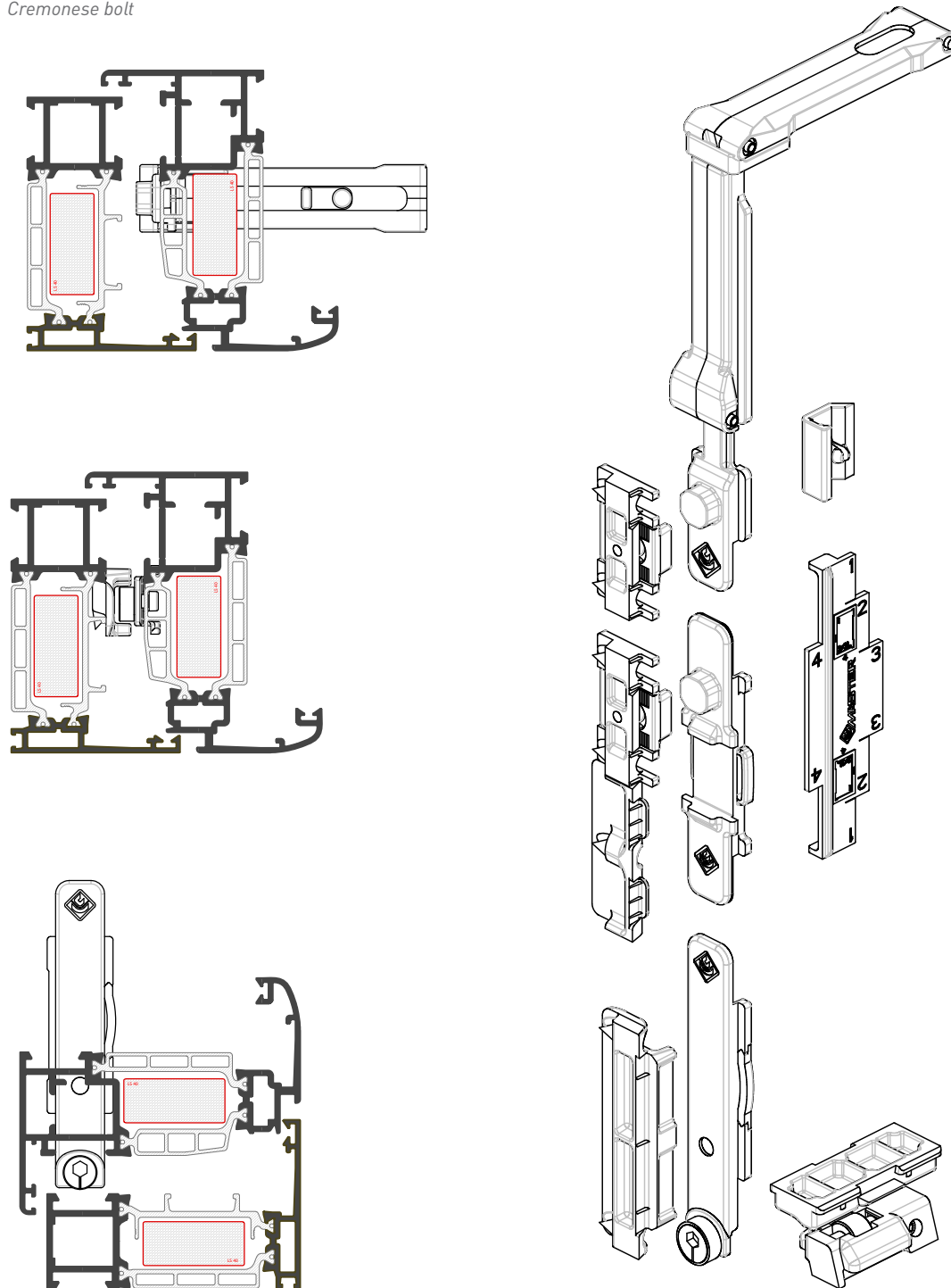

**Applicazione Accessori**

**Application of Accessories**

**ACX.08.01**

**Kit base anta ribalta**

**Portata massima 160Kg**

*tilt&turn window base kit Maximum Load 160Kg*

**RIBALTA**  
*Folding*

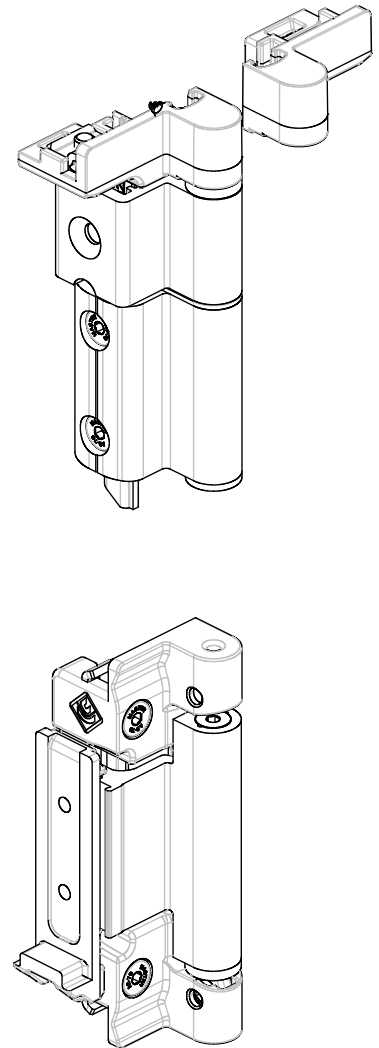
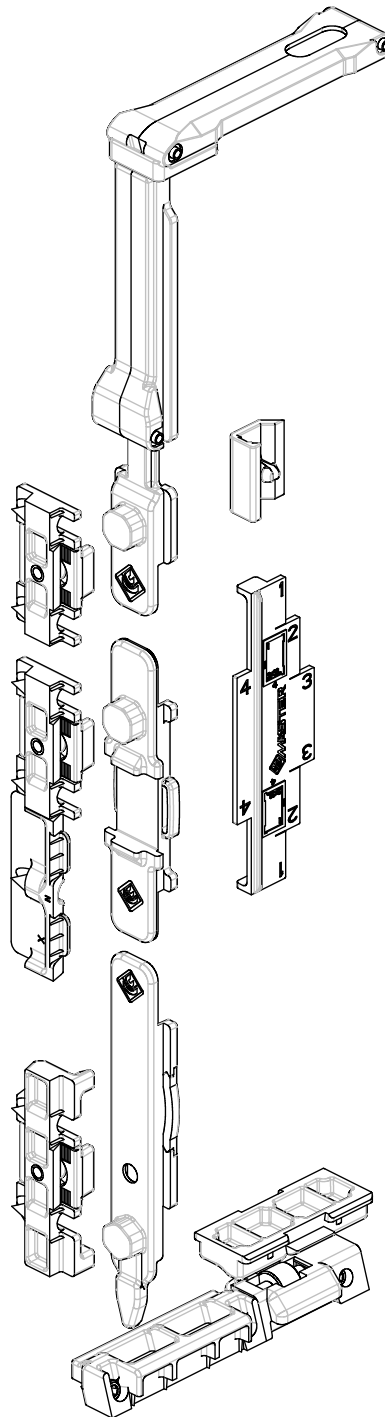
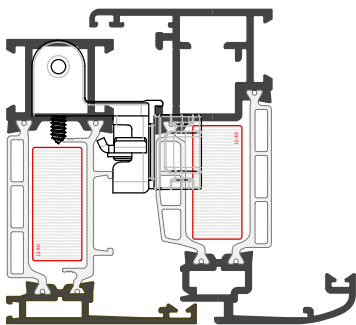
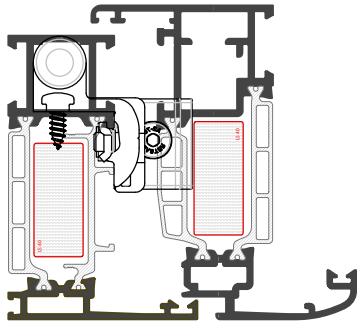

**Applicazione Accessori**

**Application of Accessories**

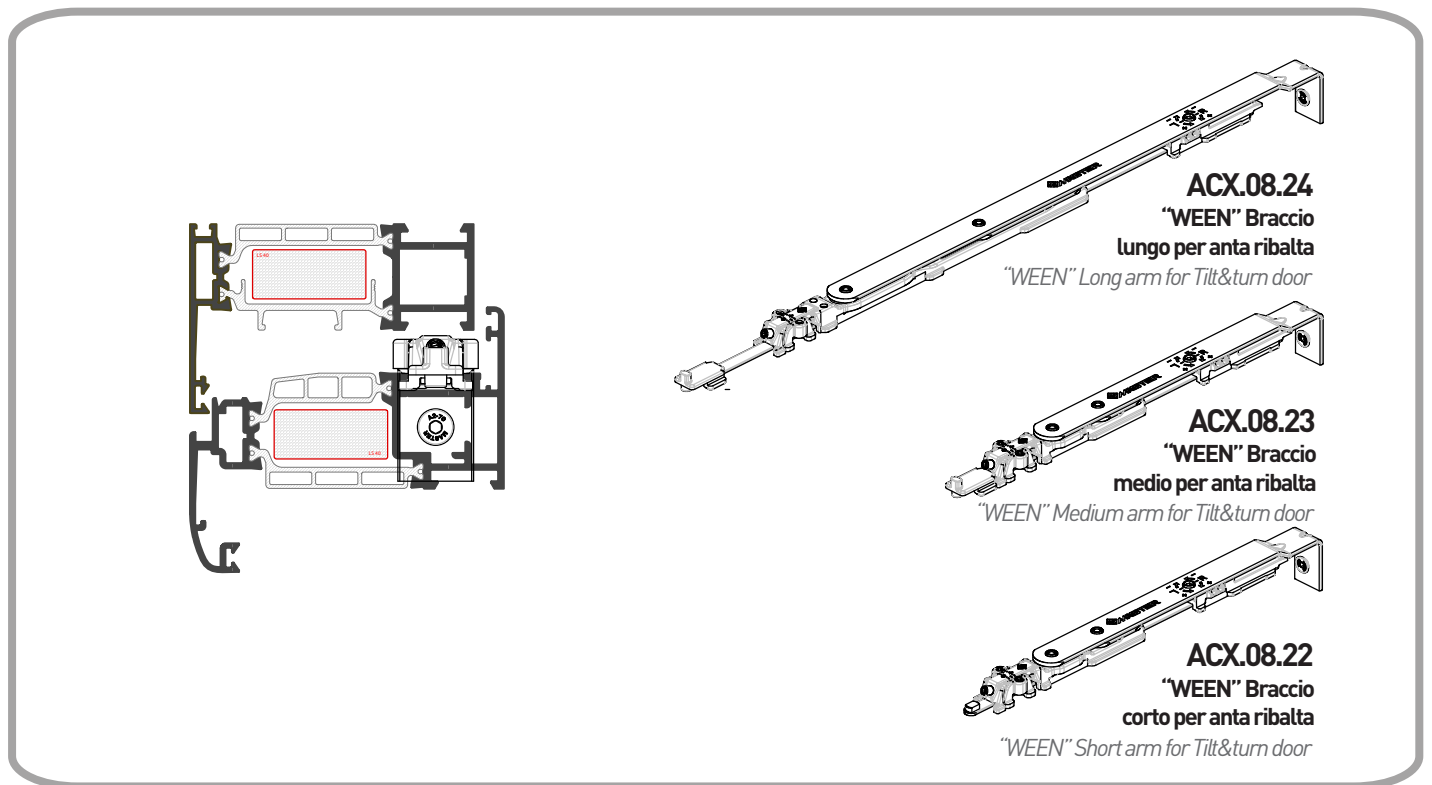
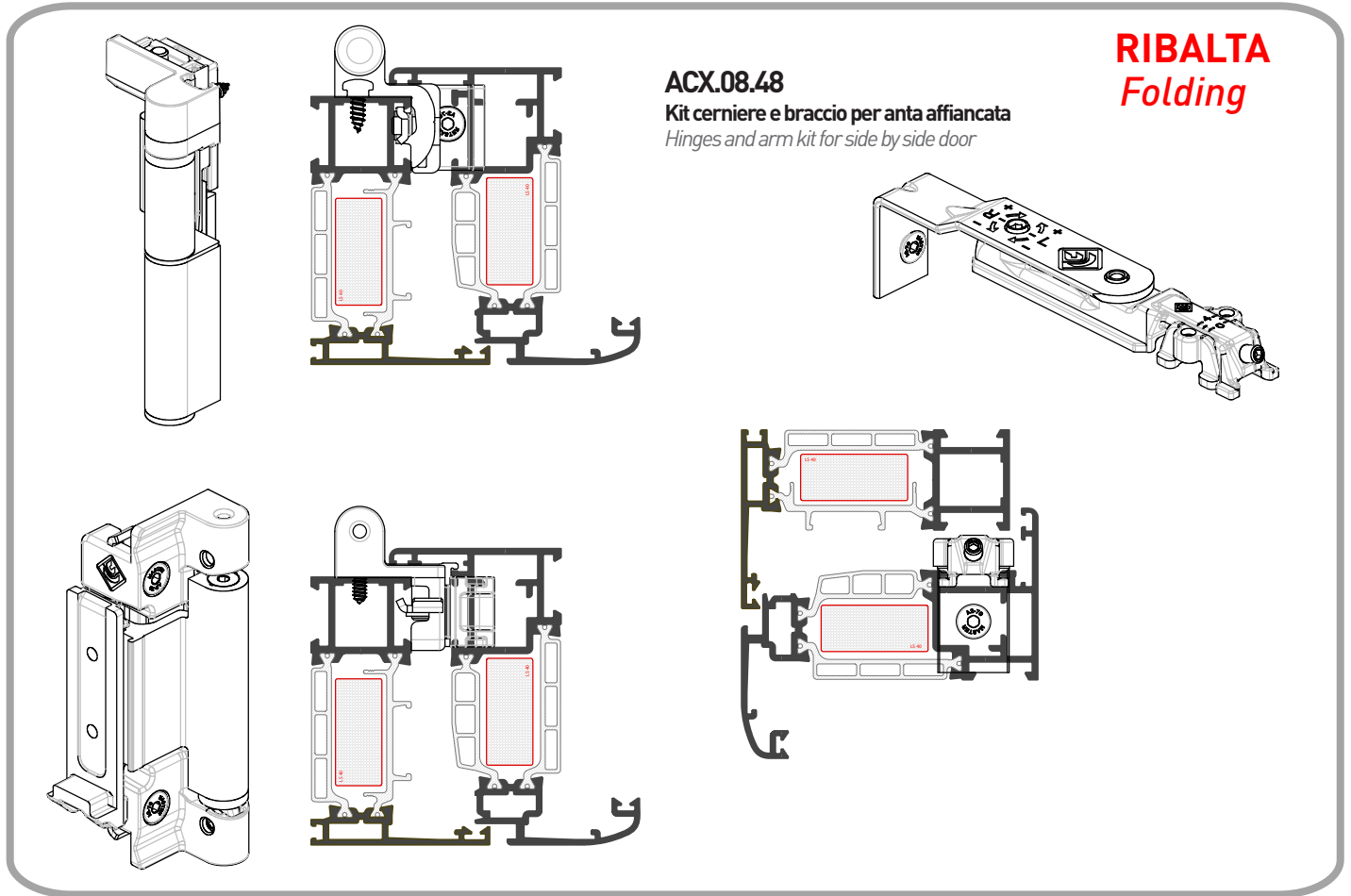

**Applicazione Accessori**

**Application of Accessories**

**RIBALTA**  
*Folding*

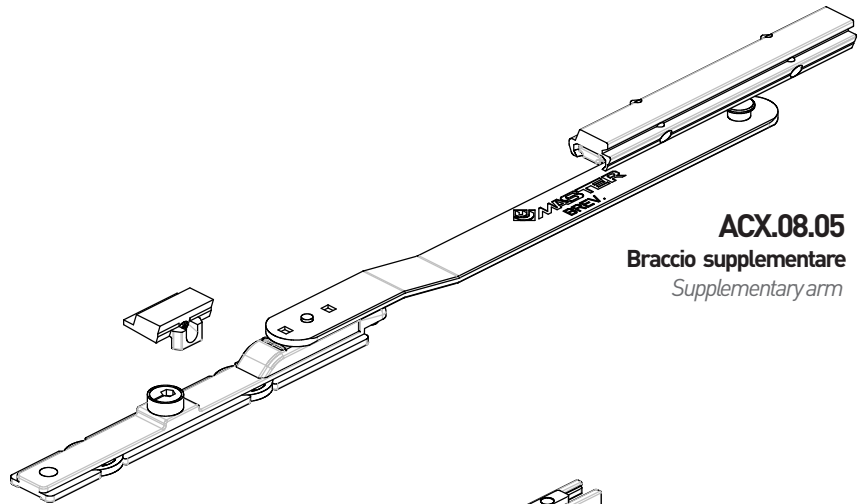
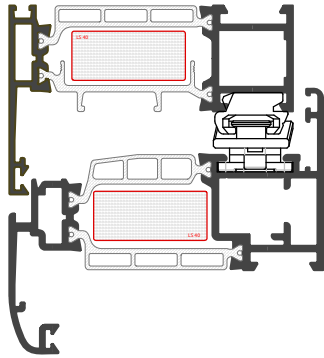

**ACX.08.05**  
Braccio supplementare  
*Supplementary arm*

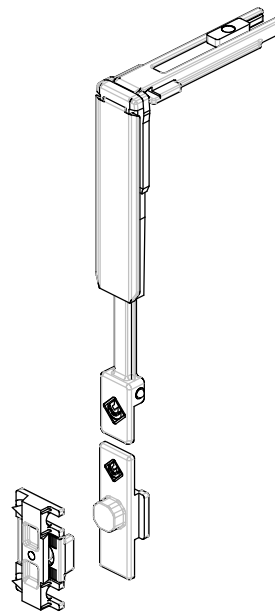
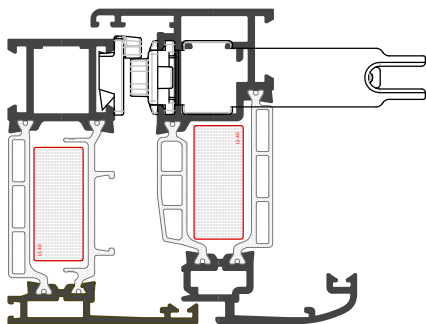

**ACX.08.06**  
"WEEN" Chiusura  
supplementare orizz./vert.  
*"WEEN" Supplementary  
Horizontal/Vert.*

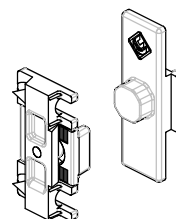
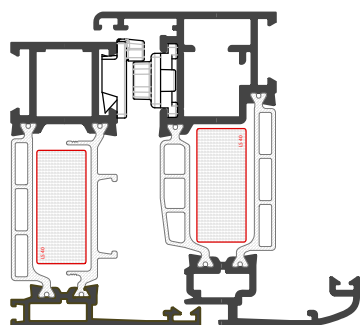

**ARX.08.16**  
"WEEN" Punto  
chiusura supplementare  
*"WEEN" Supplementary  
closing point*

**Applicazione Accessori**

**Application of Accessories**

**RIBALTA**  
**Folding**

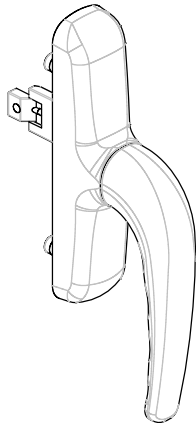

**ARX.03.08**  
Cremonese per anta ribalta  
*Cremonese bolt for Tilt&turn door*

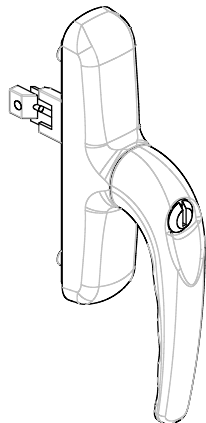
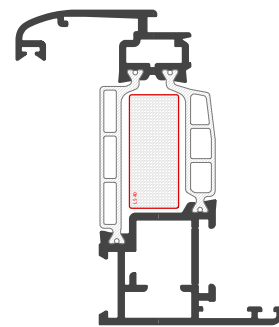
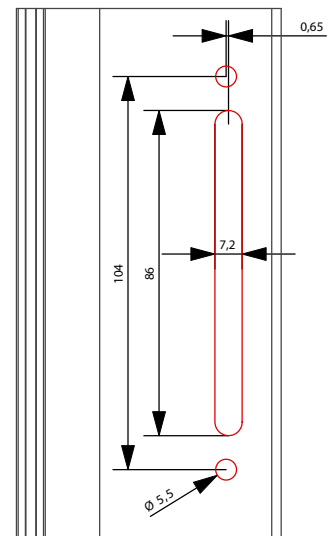
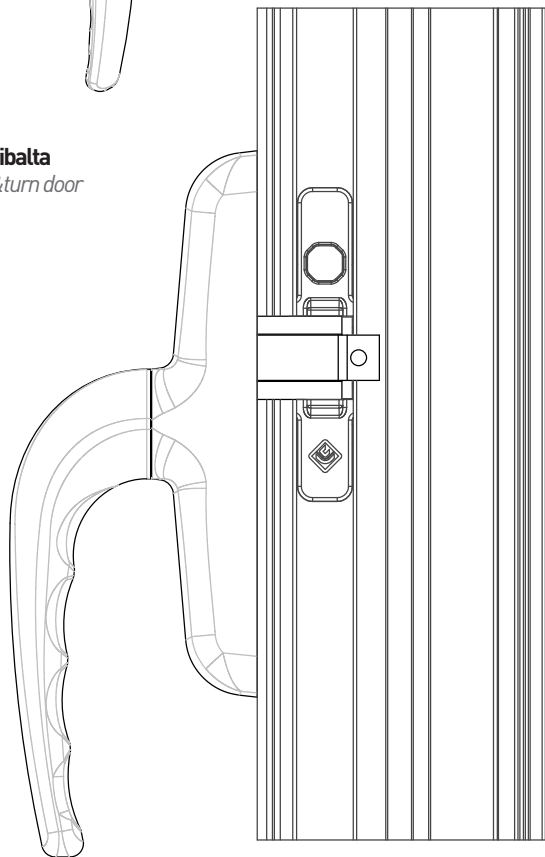

**ARX.03.46**  
Cremonese con chiave  
per anta ribalta  
*Cremonese bolt with cylinder lock  
for Tilt&turn door*

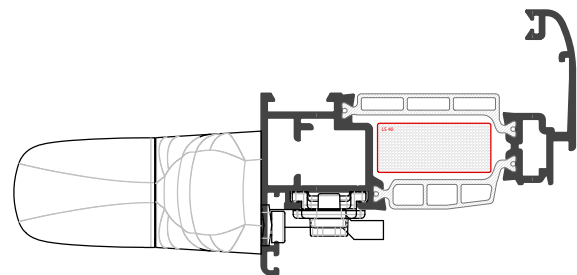

**Applicazione Accessori**

**Application of Accessories**

- Indicazioni per foratura traversi

- Indications for drilling crosspieces

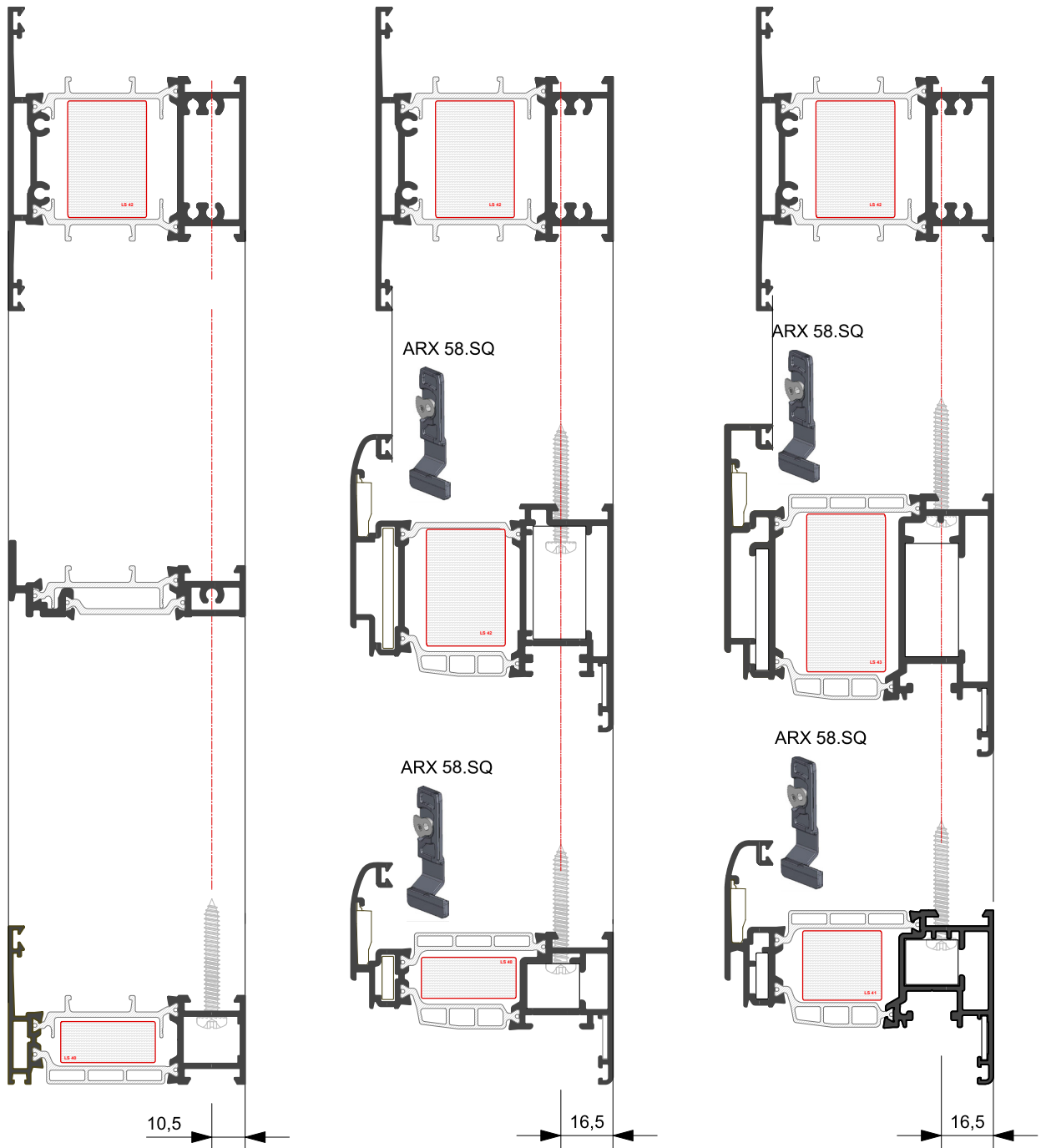

**Applicazione Accessori**

**Application of Accessories**

• Indicazioni per foratura Traversi

• Indications for drilling crosspieces

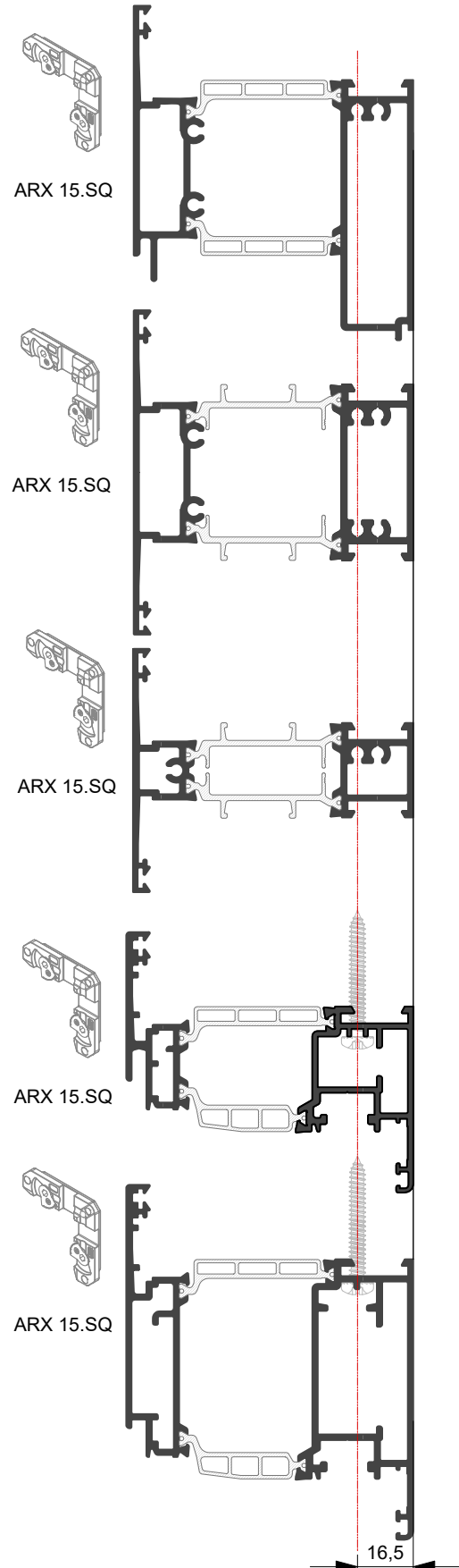
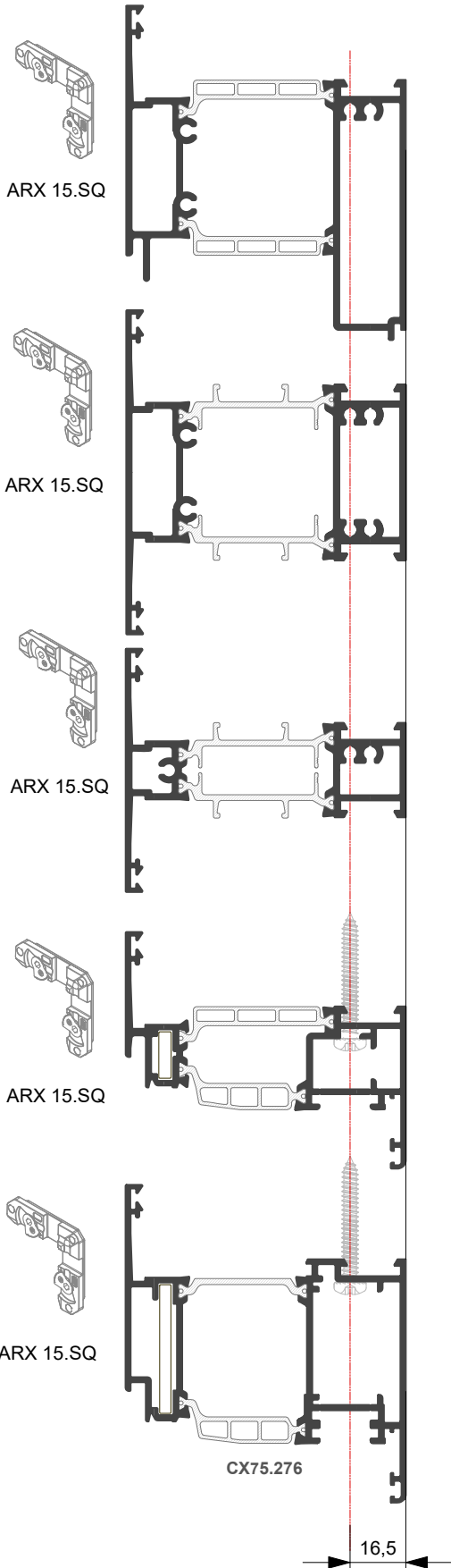

**Applicazione Accessori**

**Application of Accessories**

- Indicazioni per foratura Traversi

- Indications for drilling crosspieces

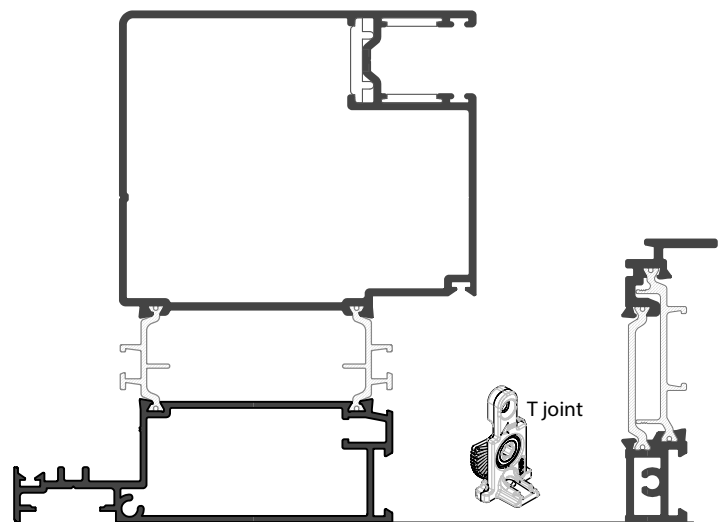
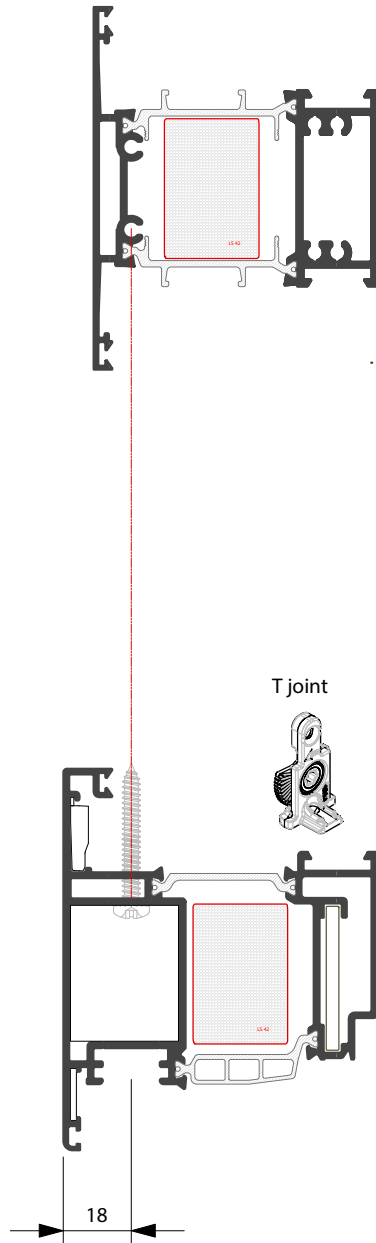



**A**

Art.19225

Contropiastra Regolabile in Metallo			
A-B	C	D	E
06463-82	06465-72	06463-82	06465-72 (pz.2)
(17) = inserto rullo art. 06141-71			

**1 ANTA**

**B**

Art.49225

CILINDRO SAGOMATO (Nichelato Fin.12)		Frontale
con borchie	senza borchie	
0E300-24-0-12 L=99 (29.5-69.5)	0E300-41-0-12 L=94 (29.5-64.5)	22x3

E= 35 mm

**C**

Art.49225

**D**

Art.49250

**E**

Art. 06443-31/36-0

**A**

Art.19225

Contropiastra Regolabile in Metallo			
A-B	C	D	E
06463-82	06465-72	06463-82	06465-72 (pz.2)
(17) = inserto rullo art. 06141-71			

**2 ANTE**

**B**

Art.49225

CILINDRO SAGOMATO (Nichelato Fin.12)		Frontale
con borchie	senza borchie	
0E300-24-0-12 L=99 (29.5-69.5)	0E300-41-0-12 L=94 (29.5-64.5)	22x3

E= 35 mm

**C**

Art.49225

**D**

Art.49250

**E**

Art. 06443-31/36-0

**A**

Art.19225

Contropiastra Regolabile in Metallo			
A-B	C	D	E
06463-82	06465-72	06463-82	06465-72 (pz.2)
(17) = inserto rullo art. 06141-71			

**1 ANTA  
Apertura  
ESTERNA**

**B**

Art.49225

CILINDRO SAGOMATO (Nichelato Fin.12)		Frontale
con borchie	senza borchie	
0E300-24-0-12 L=99 (29.5-69.5)	0E300-41-0-12 L=94 (29.5-64.5)	22x3

E= 35 mm

**C**

Art.49225

**D**

Art.49250

**E**

Art. 06443-31/36-0

**A**

Art.19225

Contropiastra Regolabile in Metallo			
A-B	C	D	E
06463-82	06465-72	06463-82	06465-72 (pz.2)
(17) = inserto rullo art. 06141-71			

**2 ANTE  
Apertura  
ESTERNA**

**B**

Art.49225

CILINDRO SAGOMATO (Nichelato Fin.12)		Frontale
con borchie	senza borchie	
0E300-24-0-12 L=99 (29.5-69.5)	0E300-41-0-12 L=94 (29.5-64.5)	22x3

E= 35 mm

**C**

Art.49225

**D**

Art.49250

**E**

Art. 06443-31/36-0



**1 ANTA**

Contropiastra Regolabile in Metallo		
A-B-C	D	E-F
06463-72	06463-72 (17)	06465-72
(17) = inserto rullo art. 06141-71		

CILINDRO SAGOMATO (Nichelato Fin.12)		Frontale
con borchie	senza borchie	
0E300-24-0-12 L=99 (29.5-69.5)	0E300-41-0-12 L=94 (29.5-64.5)	22x3

E= 35 mm

Art. 16205  
Art. 16215  
Art. 16225  
Art. 16217  
Art. 16227  
Art. 46215  
Art. 46225  
Art. 46217  
Art. 46227  
Art. 46230  
Art. 46250  
Art. 46252  
Art. 46210  
Art. 46220  
Art. 46212  
Art. 46222  
Art. 06443-00/05-0

**2 ANTE**

Contropiastra Regolabile in Metallo		
A-B-C	D	E-F
06463-72	06463-72 (17)	06465-72
(17) = inserto rullo art. 06141-71		

CILINDRO SAGOMATO (Nichelato Fin.12)		Frontale
con borchie	senza borchie	
0E300-24-0-12 L=99 (29.5-69.5)	0E300-41-0-12 L=94 (29.5-64.5)	22x3

E= 35 mm

Art. 16205  
Art. 16215  
Art. 16225  
Art. 16217  
Art. 16227  
Art. 46215  
Art. 46225  
Art. 46217  
Art. 46227  
Art. 46230  
Art. 46250  
Art. 46252  
Art. 46210  
Art. 46220  
Art. 46212  
Art. 46222  
Art. 06443-00/05-0

**1 ANTA Apertura ESTERNA**

Contropiastra Regolabile in Metallo		
A-B-C	D	E-F
06463-72	06463-72 (17)	06465-72
(17) = inserto rullo art. 06141-71		

CILINDRO SAGOMATO (Nichelato Fin.12)		Frontale
con borchie	senza borchie	
0E300-24-0-12 L=99 (29.5-69.5)	0E300-41-0-12 L=94 (29.5-64.5)	22x3

E= 35 mm

Art. 16205  
Art. 16215  
Art. 16225  
Art. 16217  
Art. 16227  
Art. 46215  
Art. 46225  
Art. 46217  
Art. 46227  
Art. 46230  
Art. 46250  
Art. 46252  
Art. 46210  
Art. 46220  
Art. 46212  
Art. 46222  
Art. 06443-00/05-0

**2 ANTE Apertura ESTERNA**

Contropiastra Regolabile in Metallo		
A-B-C	D	E-F
06463-72	06463-72 (17)	06465-72
(17) = inserto rullo art. 06141-71		

CILINDRO SAGOMATO (Nichelato Fin.12)		Frontale
con borchie	senza borchie	
0E300-24-0-12 L=99 (29.5-69.5)	0E300-41-0-12 L=94 (29.5-64.5)	22x3

E= 35 mm

Art. 16205  
Art. 16215  
Art. 16225  
Art. 16217  
Art. 16227  
Art. 46215  
Art. 46225  
Art. 46217  
Art. 46227  
Art. 46230  
Art. 46250  
Art. 46252  
Art. 46210  
Art. 46220  
Art. 46212  
Art. 46222  
Art. 06443-00/05-0



**1 ANTA**

Contropiastra Regolabile in Metallo			
A	B	C	Deviatori
06463-82	06463-82	06465-72	06465-72 (pz.2)
(B) Kit rullo art. 06000-00			

CILINDRO SAGOMATO (Nichelato Fin.12)		Frontale
con borchie	senza borchie	
0E300-24-0-12 L=99 (29.5-69.5)	0E300-41-0-12 L=94 (29.5-64.5)	24x3

Art. 19526  
Art. 49526

E= 35 mm

18

Art. 49526

Art. 49526

**2 ANTE**

Contropiastra Regolabile in Metallo			
A	B	C	Deviatori
06463-82	06463-82	06465-72	06465-72 (pz.2)
(B) Kit rullo art. 06000-00			

CILINDRO SAGOMATO (Nichelato Fin.12)		Frontale
con borchie	senza borchie	
0E300-24-0-12 L=99 (29.5-69.5)	0E300-41-0-12 L=94 (29.5-64.5)	24x3

Art. 19526  
Art. 49526

E= 35 mm

18

Art. 49526

Art. 49526

**1 ANTA**  
**Apertura ESTERNA**

Contropiastra Regolabile in Metallo			
A	B	C	Deviatori
06463-82	06463-82	06465-72	06465-72 (pz.2)
(B) Kit rullo art. 06000-00			

CILINDRO SAGOMATO (Nichelato Fin.12)		Frontale
con borchie	senza borchie	
0E300-24-0-12 L=99 (29.5-69.5)	0E300-41-0-12 L=94 (29.5-64.5)	24x3

Art. 19526  
Art. 49526

E= 35 mm

18

Art. 49526

Art. 49526

**2 ANTE**  
**Apertura ESTERNA**

Contropiastra Regolabile in Metallo			
A	B	C	Deviatori
06463-82	06463-82	06465-72	06465-72 (pz.2)
(B) Kit rullo art. 06000-00			

CILINDRO SAGOMATO (Nichelato Fin.12)		Frontale
con borchie	senza borchie	
0E300-24-0-12 L=99 (29.5-69.5)	0E300-41-0-12 L=94 (29.5-64.5)	24x3

Art. 19526  
Art. 49526

E= 35 mm

18

Art. 49526

Art. 49526



**1 ANTA**

Contropiastra Regolabile in Metallo			
A	B	C	Deviatori
06463-82	06463-82	-	06465-72 (pz.2)

CILINDRO SAGOMATO (Nichelato Fin.12)		Frontale
con borchie	senza borchie	
0E300-24-0-12 L=99 (29.5-69.5)	0E300-41-0-12 L=94 (29.5-64.5)	24x3

Art. 4A000  
Art. 4A010

E= 35 mm

Art. 4A300  
Art. 4A310

**2 ANTE**

Contropiastra Regolabile in Metallo			
A	B	C	Deviatori
06463-82	06463-82	-	06465-72 (pz.2)

CILINDRO SAGOMATO (Nichelato Fin.12)		Frontale
con borchie	senza borchie	
0E300-24-0-12 L=99 (29.5-69.5)	0E300-41-0-12 L=94 (29.5-64.5)	24x3

Art. 4A000  
Art. 4A010

E= 35 mm

Art. 4A300  
Art. 4A310

**1 ANTA  
Apertura ESTERNA**

Contropiastra Regolabile in Metallo			
A	B	C	Deviatori
06463-82	06463-82	-	06465-72 (pz.2)

CILINDRO SAGOMATO (Nichelato Fin.12)		Frontale
con borchie	senza borchie	
0E300-24-0-12 L=99 (29.5-69.5)	0E300-41-0-12 L=94 (29.5-64.5)	24x3

Art. 4A000  
Art. 4A010

E= 35 mm

Art. 4A300  
Art. 4A310

**2 ANTE  
Apertura ESTERNA**

Contropiastra Regolabile in Metallo			
A	B	C	Deviatori
06463-82	06463-82	-	06465-72 (pz.2)

CILINDRO SAGOMATO (Nichelato Fin.12)		Frontale
con borchie	senza borchie	
0E300-24-0-12 L=99 (29.5-69.5)	0E300-41-0-12 L=94 (29.5-64.5)	24x3

Art. 4A000  
Art. 4A010

E= 35 mm

Art. 4A300  
Art. 4A310



**1 ANTA**

Contropiastra Regolabile in Metallo			
A	B	C	Deviatori
06463-72	06463-72 (17)	06465-72	06465-72
(17) = inserto rullo art. 06141-71			

CILINDRO SAGOMATO (Nichelato Fin.12)		Frontale
con borchie	senza borchie	
0E300-24-0-12 L=99 (29.5-69.5)	0E300-41-0-12 L=94 (29.5-64.5)	24x3

E= 35 mm

Art. 16525  
Art. 46525

Art. 46550

Art. 46520

**2 ANTE**

Contropiastra Regolabile in Metallo			
A	B	C	Deviatori
06463-72	06463-72 (17)	06465-72	06465-72
(17) = inserto rullo art. 06141-71			

CILINDRO SAGOMATO (Nichelato Fin.12)		Frontale
con borchie	senza borchie	
0E300-24-0-12 L=99 (29.5-69.5)	0E300-41-0-12 L=94 (29.5-64.5)	24x3

E= 35 mm

Art. 16525  
Art. 46525

Art. 46550

Art. 46520

**1 ANTA  
Apertura ESTERNA**

Contropiastra Regolabile in Metallo			
A	B	C	Deviatori
06463-72	06463-72 (17)	06465-72	06465-72
(17) = inserto rullo art. 06141-71			

CILINDRO SAGOMATO (Nichelato Fin.12)		Frontale
con borchie	senza borchie	
0E300-24-0-12 L=99 (29.5-69.5)	0E300-41-0-12 L=94 (29.5-64.5)	24x3

E= 35 mm

Art. 16525  
Art. 46525

Art. 46550

Art. 46520

**2 ANTE  
Apertura ESTERNA**

Contropiastra Regolabile in Metallo			
A	B	C	Deviatori
06463-72	06463-72 (17)	06465-72	06465-72
(17) = inserto rullo art. 06141-71			

CILINDRO SAGOMATO (Nichelato Fin.12)		Frontale
con borchie	senza borchie	
0E300-24-0-12 L=99 (29.5-69.5)	0E300-41-0-12 L=94 (29.5-64.5)	24x3

E= 35 mm

Art. 16525  
Art. 46525

Art. 46550

Art. 46520



**A**

Contropiastra Regolabile in Metallo		Accessori		
A	Deviatori	1/2 Maniglia	Aste	Blocca Aste
06463-82	06465-72 (pz.2)	07070-66-0-B1	-	-
Utilizzare salvaprofilo art. -		Bocchetta Pavimento art. -		
CILINDRO SAGOMATO (Nichelato Fin.12)		Frontale		
con borchie		senza borchie		24x3
0E300-24-0-12 L=99 (29.5-69.5)	0E300-41-0-12 L=94 (29.5-64.5)			

E= 40 mm

**1 ANTE Apertura ESTERNA**

Art. 43725 Funz. A/D  
Art. 43735 Funz. B

Maniglione FAST Touch  
Quadro 8mm  
art. 59711-00  
art. 59711-01

Quadro Maniglia  
art. 07085-77-0

Maniglione FAST Push  
Quadro 8mm  
art. 59607-10

Barra Ovale  
art. 07007-XX

**A**

Contropiastra Regolabile Metallo		Accessori		
A	Deviatori	1/2 Maniglia	Aste	Blocca Aste
43295-75	06465-72 (pz.2)	07070-66-0-B1	07088-03	07089-52 (Facoltativo)
Utilizzare salvaprofilo art. -		Bocchetta Pavimento (in dotazione alla contro serratura) art. 06142-85		
CILINDRO SAGOMATO (Nichelato Fin.12)		Frontale		
con borchie		senza borchie		24x3
0E300-24-0-12 L=99 (29.5-69.5)	0E300-41-0-12 L=94 (29.5-64.5)			

E= 40 mm

**2 ANTE Apertura ESTERNA**

Art. 43725 Funz. A/D  
Art. 43735 Funz. B

Maniglione FAST Touch  
Quadro 8mm  
art. 59711-00  
art. 59711-01

Quadro Maniglia  
art. 07085-77-0

Maniglione FAST Push  
Quadro 8mm  
art. 59607-10

Barra Ovale  
art. 07007-XX

**A Bocchetta Superiore**

Art. 06141-80

**B Boccola**

Art. 06147-01

**C Blocca Aste**

Art. 07089-52

**A Aste**

Art. 07088-03

**Sez. Verticale RIARMO MANUALE**

19

**A Bocchetta Superiore**

Art. 06141-80

**B Boccola**

Art. 06147-01

**C Blocca Aste**

Art. 07089-52

**A Aste**

Art. 07088-03

**Sez. Verticale RIARMO AUTOMATICO**

18

21,5



MANIGLIONI ANTIPANICO -  
APPLICARE FAST

**FAST PUSH**

- 59001-10-0
- 59011-10-0
- 59016-10-0

**Barra Ovale**

- 07007-14-0 (acciaio verniciato)
- 07007-61-0 (inox)

**FAST TOUCH (L=1200)**

- 59801-10-0
- 59811-10-0
- 59816-10-0

**FAST TOUCH (L=840)**

- 59801-09-0
- 59811-09-0
- 59816-09-0

**eFAST**

- 59851-10-0

**Coppia Alto Basso**  
07063-61-0

**Coppia Laterale**  
07063-51-0

**Coppia Catenacci**  
07063-71-0

**Comandi Esterni**

- 07078-68-0
- 07078-69-0
- 07078-38-0
- 07078-36-0
- 07078-35-0

**Accessori**

- Kit Prolunga 07064-51-0
- Incontro Laterale 07072-11-0
- Micro Fast Touch 06195-05-0
- Micro Fast Push 06195-06-0
- Micro Comando Est. 06195-10-0
- Passacavo 06515-21-0
- Ingegno 06198-70-0

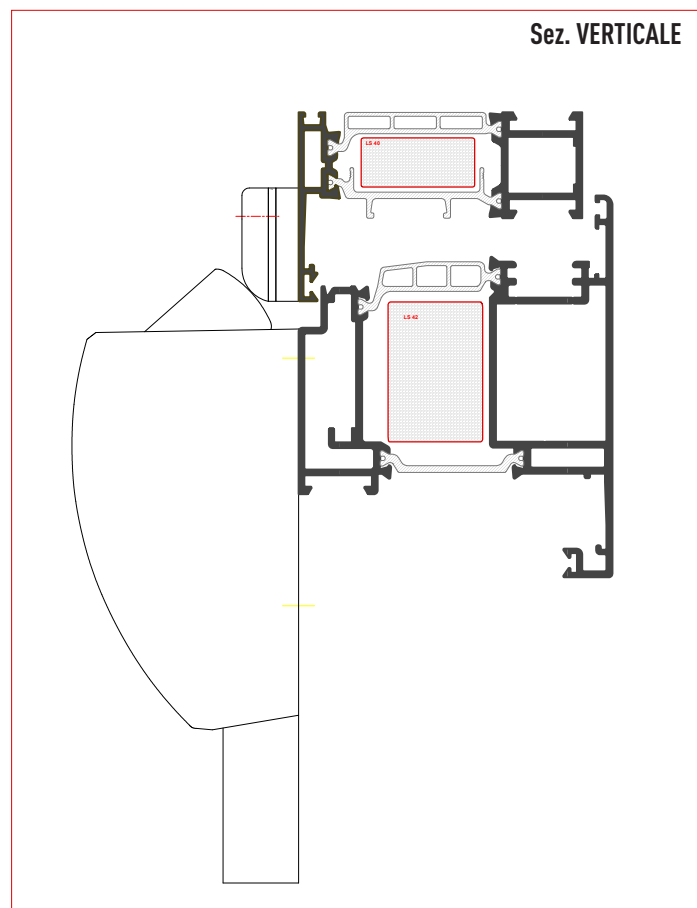
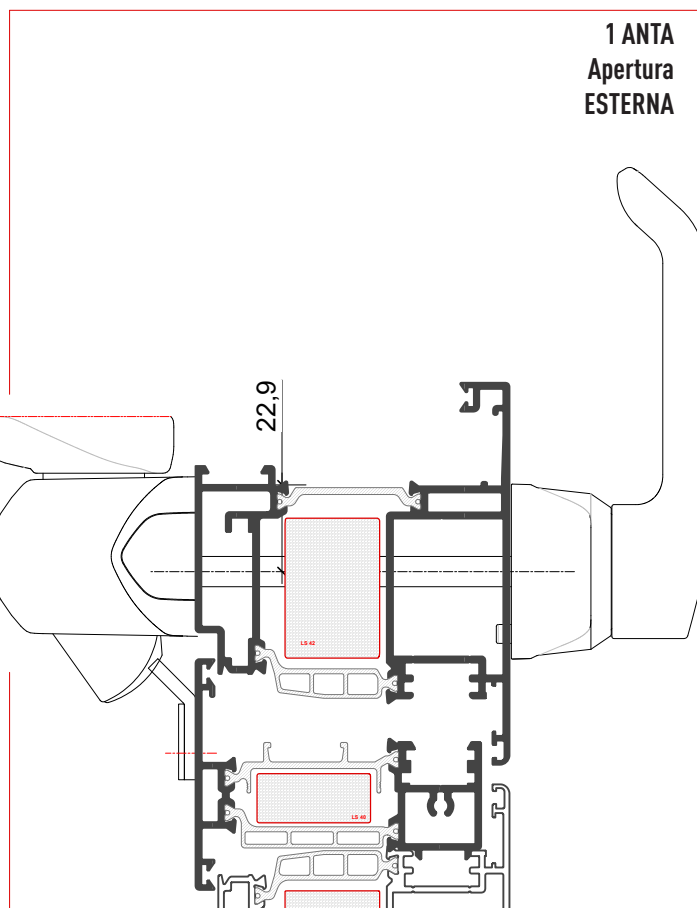
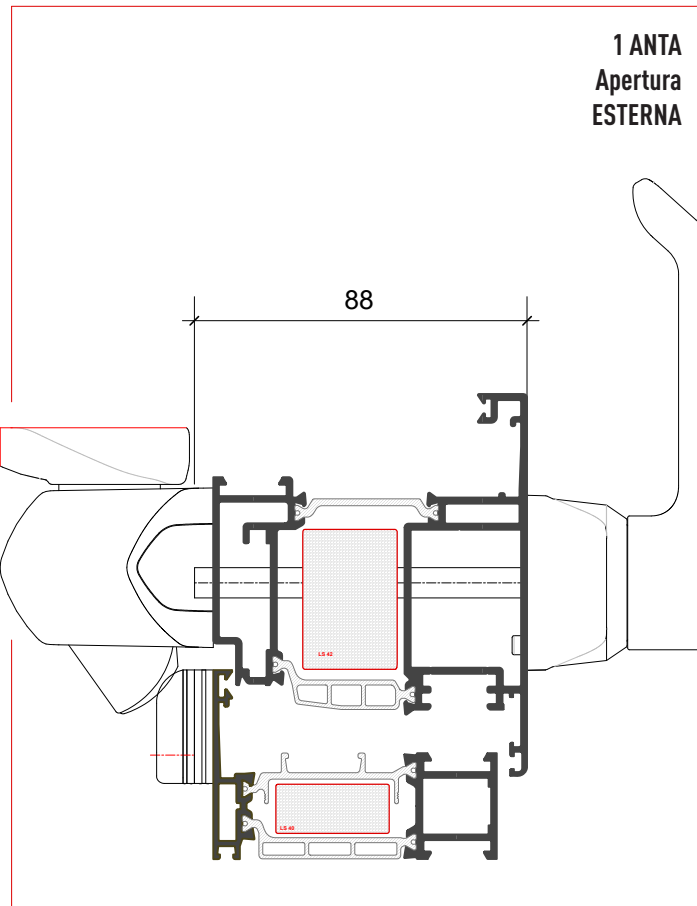



MANIGLIONI ANTIPANICO -  
APPLICARE FAST

Sez.  
ORIZZONTALE

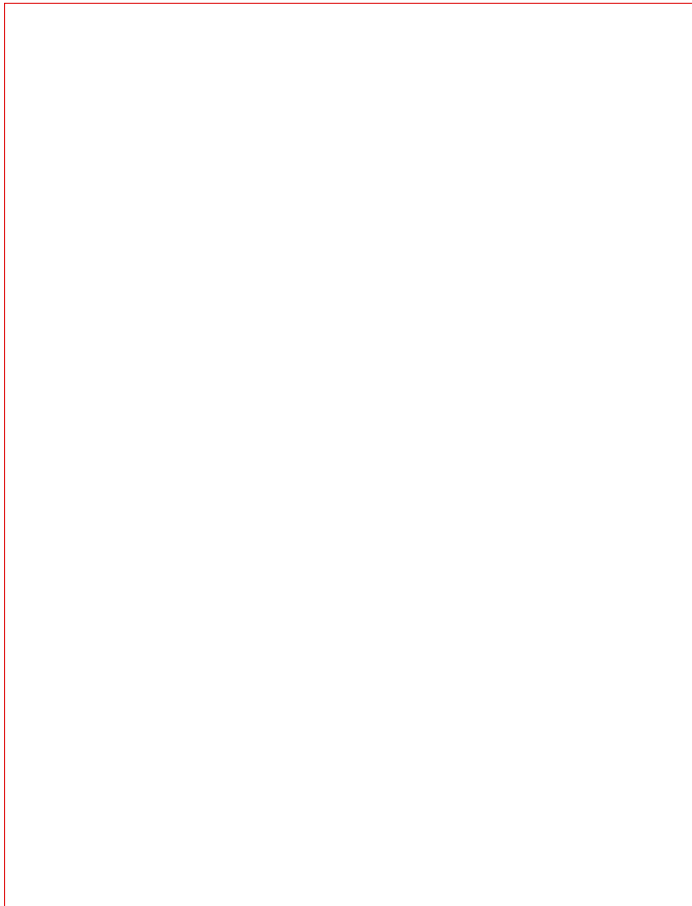
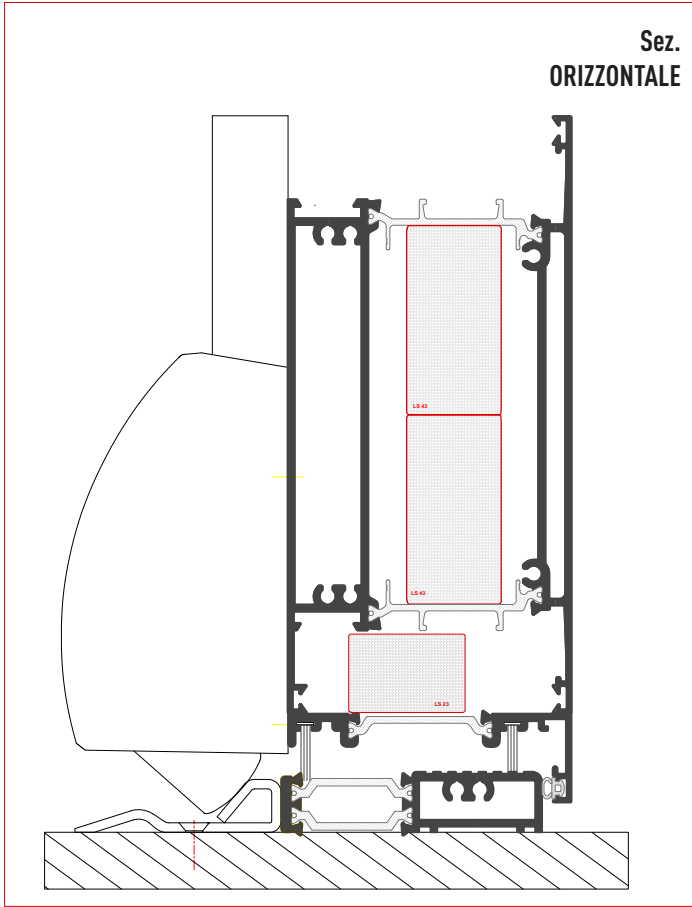



I Cataloghi TWIN SYSTEMS disponibili in formato pdf **QUI**  
*TWIN SYSTEMS catalogues available as pdf file* **HERE** [www.twinsystems.it/professionisti/cataloghi/](http://www.twinsystems.it/professionisti/cataloghi/)

**PAGINA** Cataloghi  
**CATALOGUES** Webpage

**LINEA** PRODOTTI  
**PRODUCTS** Line

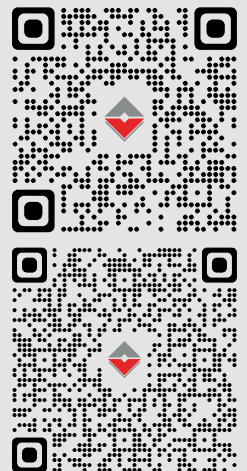

## PAM SYSTEM S.r.L.

S.S. 230 - Fornace Crocicchio 13030 Formigliana (VC)  
Tel. 0161 858811 - Fax 0121 858800  
www.pamsystemsrl.com | info@pamsystemsrl.com

## ALQ GENOVA s.r.l.

### Direzione & Magazzino

Via Colano, 9/A 12/K 16162 Genova Bolzaneto (GE)  
Tel. 010 7491941 - Fax 010 7450155

### Magazzino

Via Meucci, 25 Calenzano 50041 (FI)  
Tel. +39 055 8825060 Fax: +39 055 8824916  
www.alqsystem.it | info@alqgenovasrl.com

## PAESANI GROUP

### Direzione & Magazzino

Via del Grano, 260 47822 Santarcangelo di Romagna (RN)  
Tel. 0541 748511

www.paesani.com | info@paesani.com

### Magazzino Nord

Via Luigi Bonati, 21 29017 Fiorenzuola d'Arda (PC)  
Tel. 0523 943138  
magazzinonord@paesani.com

## DIVA s.a.s

Via Po, 25 - Z.I. Sambuceto 66020 S.Giovanni Teatino (CH)  
Tel. 085 4405210 - Fax 085 4405207

www.camel-diva.com | info@camel-diva.com

## EUROALL S.r.l.

Strada Comunale della Mola Saracena, 23 00065 Fiano Romano (RM)

Tel. 0765 455228/61 - Fax 0765 455317

www.euroallslrl.it | info@euroallslrl.it

## PROFILATI UMBRIA S.r.l.

Via Dei Tigli, 35 - 06083 Bastia Umbra (PG)  
Tel. 075 8012385 | 075 8010328 - Fax 075 8012386  
info@profilatiumbria.it

## TSL ALLUMINIO S.r.l.

Via delle Industrie, 12 00030 San Cesario (Roma)  
Tel. 06 2251591 (Ric. Aut.) - Fax 06 2280693  
www.tslalluminio.it | info@tsllalluminio.it

## ALLCAR SERVICE S.r.l.

Via Acuto, 120 - 00131 Roma  
Tel. 06 4130626 (Ric. Aut.) - Fax 06.4130367  
www.allcarservice.it | allcarservice@mclink.it

## ALLUCOM S.r.l.

### Andria

Via Nemesiano 60/62 Zona PIP - 76123 Andria (BT)  
Tel. 0883 592213 - Fax 0883 552386

### Bari

Via Zippitelli, 28/B - 70123 (BA)  
Tel. 0805058608 - Fax 0805058607  
www.allucom.com | info@allucom.com

## CARUSO S.r.l.

Z.I. Contrada Le Macere 86019 Vinchiatturo (CB)  
Tel. 0874 340024 - Fax 0874340025  
carusosrl1@libero.it

## CAIMAR S.R.L.

### Direzione & Magazzino

Strada Prov.le Rimedio-Torregrande Km. 4  
09072 Cabras (OR) - Tel. 0783 290118

### Filiale

Fronte S.S. 131 Km. 17,450 - 09023 Monastir (CA)  
Tel. 070 9166020 - Fax 070 9166191  
www.caimar.it | caimarmail@caimar.it

## SALENTO METALLI S.r.l.

Via Federico II, 13 - Zona PIP - 73020 Cavallino (LE)  
Tel. 0832 614576 - Fax 0832 614635  
www.salentometalli.it | info@salentometalli.it

## MIDA ALLUMINIO S.r.l.

### Napoli

Via Piano del Principe, 36  
80047 San Giuseppe Vesuviano (NA)  
Tel. 081 5297373 - Fax 081 8284449

### Salerno

Loc. Terzerie, Z.I. - 80061 Ogliastro Cilento (SA)  
Tel. 0974 833233 - Fax 0974 844724  
www.gruppomida.it | info@gruppomida.it

## ITALBACOLOR S.r.l.

C.da Valle S. Maria - 87024 Fuscaldo (CS)  
Tel. 0982 618025 - Fax 0982 720235  
www.italbacolor.it | commerciale@italbacolor.it

## COMAS S.r.l.

Via Porta Palermo, 84 - 91011 Alcamo (TP)  
Tel. 0924 507050 - Fax 0924 507051  
www.comasgroup.it | info@comasgroup.it

## ALUK TIM

### Aluk Tim D.o.o.

Žegoti 10, 51215 Kastav Croazia, UE  
Tel: +385 (0) 51/691 461 - Fax: +385 (0) 51/691 473

### Filiale di Zagabria

Franje Lučića, 34A Zagabria Croazia, UE  
Tel: +385 (0) 1 6462 611 - Fax: +385 (0) 1 6462 610  
Mob: +385 (0) 99 2939656

zagreb@aluk.hr

### Filiale Spalato

Street Sv. Nikole Tavelića, 13A 21204  
Dugopolje Croazia, UE  
Tel: +385 (0) 21225525  
Fax: +385 (0) 21660110  
Mob: +385 (0) 99 2199228  
split@aluk.hr



  [www.twinsystems.it](http://www.twinsystems.it)  
[info@twinsystems.it](mailto:info@twinsystems.it)

Consorzio TWIN SYSTEMS

Via delle Macere, 20 | 00060 Formello [Roma]  
Tel./Fax 06 23260298