

HM160

FINESTRE e PORTE ALZANTI / SCORREVOLI
SLIDING/LIFTING WINDOWS AND DOORS

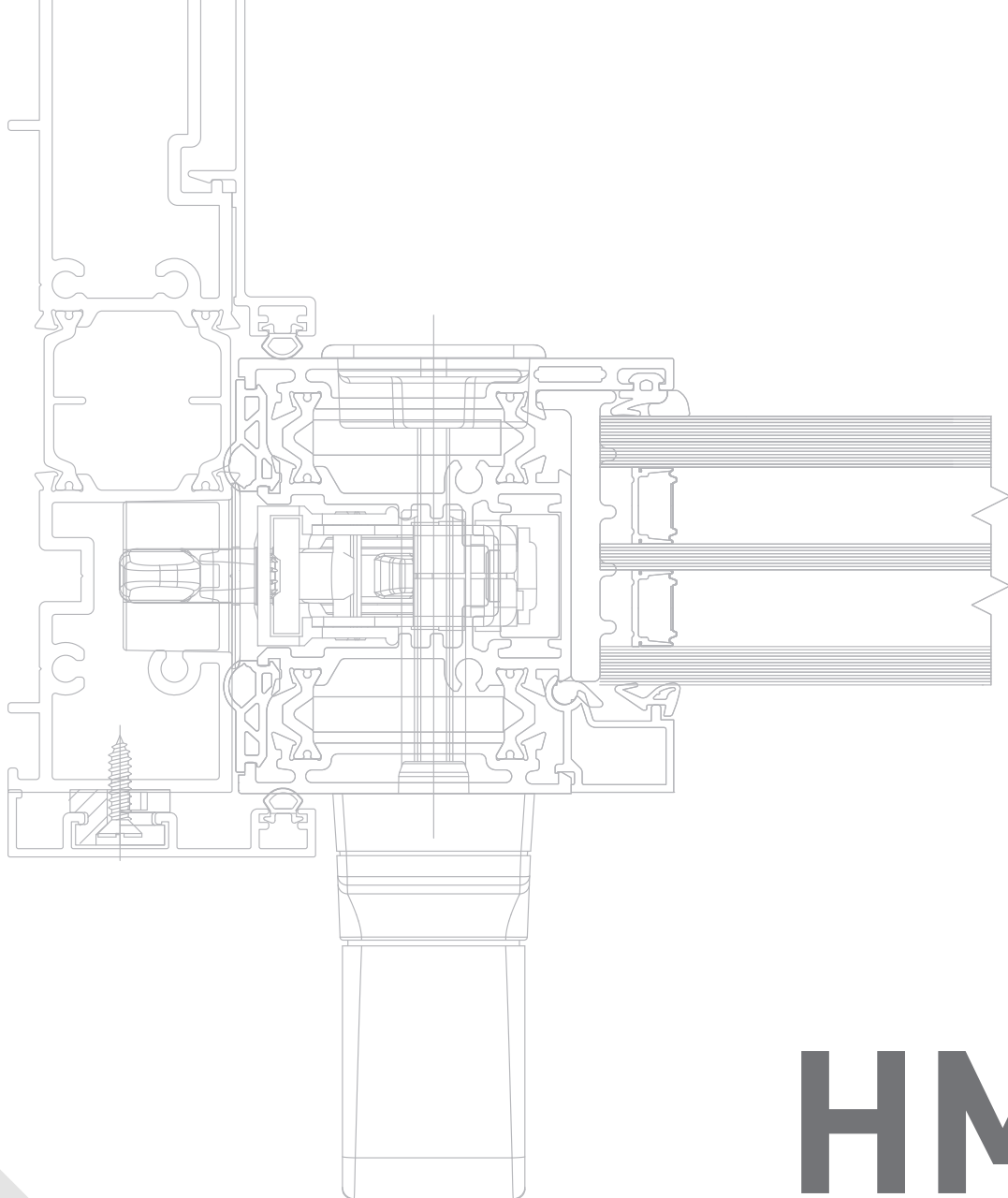



HM160

FINESTRE e PORTE ALZANTI / SCORREVOLI
WINDOW AND DOORS SLIDING/LIFITING





TWIN SYSTEMS

ARCHITETTURE IN ALLUMINIO



Gruppo A Informazioni Generali *General Infos*

Indice Generale
Caratteristiche Alluminio
Descrizione Tecnica sistema
Descrizione Tecnica Capitolato
Collaudi Prestazionali

*Table of Contents
Aluminium Characteristics
Technical Description
Technical Specifications
Performance Tests*

Gruppo B Profili *Profiles*

Elenco Profili
Profili Scala 1:1

*Profiles List
Profiles Scale 1:1*

Gruppo C Accessori e Guarnizioni *Accessories and Gaskets*

Elenco accessori
Elenco guarnizioni

*List of Accessories
List of Window Gaskets*

Gruppo D Nodi *Main Sections*

Sezioni principali
e Accessori
Sc. 1:1

*Main Sections and
Accessories
Scale 1:1*

Gruppo E Tipologie *Types*

Tipologie

Types

Gruppo F Attacco alla Muratura *Wall Joint*

Sezione particolareggiata
attacco alla muratura

Wall Joint Detail

Gruppo G Lavorazioni/Montaggi *Tooling/Assembly*

Schemi Lavorazioni
Frese
Attrezzatura

*Tooling Systems
Cutters Equipments
Milling*

Tutti i dati riportati sul presente catalogo sono indicativi e non impegnativi. La società si riserva il diritto di apportare in qualsiasi momento modifiche atte a migliorare i prodotti. Per informazioni tecniche riguardanti il catalogo contattare l'ufficio tecnico.

All the data shown in this catalog are indicative and not binding. The company reserves the right to make changes to improve the products at any time. For technical information regarding the catalog, contact the technical department.



Informazioni Generali
General Information

Gruppo A

Indice Generale	<i>Table of Contents</i>
Caratteristiche Alluminio	<i>Aluminium Characteristics</i>
Descrizione Tecnica sistema	<i>Technical Description</i>
Descrizione Tecnica Capitolato	<i>Technical Specifications</i>
Collaudi Prestazionali	<i>Performance Tests</i>

**PESO PROFILATI**

Il peso indicato è quello teorico e potrà variare in funzione delle tolleranze di spessore e dimensionali dei profilati (NORMA UNI EN 12020-2)

LEGA DI ESTRUSIONE

I profilati sono estrusi in lega EN-AW-6060 (UNI EN 573/3)

DIMENSIONI DEI PROFILATI

Le dimensioni indicate sono quelle teoriche, potranno quindi variare in funzione delle tolleranze dimensionali di estrusione (norma UNI EN 12020-2). Questa variabilità che interessa tutti i profilati, può influire, anche se minimamente, sulle dimensioni di taglio e quindi finali del serramento. Anche la verniciatura, aumentando gli spessori, contribuisce a far variare la dimensione dei profilati e, particolarmente, riduce lo spazio nelle sedi di inserimento delle guarnizioni e degli accessori.

DIMENSIONI DI TAGLIO E LAVORAZIONI

Le dimensioni teoriche di taglio e le quote delle lavorazioni indicate nel presente catalogo sono esatte, ovvero matematicamente corrette, in certi casi dovranno, nella pratica, essere adattate in base alla precisione ed al tipo di impostazione delle misure delle macchine utilizzate. È pertanto consigliabile nei primi lavori o nel caso di importanti quantità di serramenti effettuare delle campionature di prova.

PROTEZIONE SUPERFICIALE

Al fine di limitare i processi di corrosione filiforme è importante applicare le seguenti regole:

- ◆ **Utilizzare accessori di assemblaggio in alluminio**
- ◆ **Utilizzare viti in acciaio inox**
- ◆ **Proteggere le parti tagliate e lavorate con prodotti idonei**
- ◆ **Evitare ristagni di condense all'interno dei profilati.**

Per la realizzazione di serramenti è necessario attenersi alla tecnologia costruttiva e utilizzare le guarnizioni e gli accessori originali riportati sul catalogo tecnico e al rispetto delle norme, prescrizioni e raccomandazioni vigenti. L'osservanza di quanto sopra determina la garanzia. Su queste basi sono stati realizzati campioni che, collaudati in laboratorio hanno ottenuto i risultati indicati nelle certificazioni. Per il buon funzionamento e la durata degli infissi realizzati con profilati ed accessori del sistema, è necessario effettuare alcune semplici operazioni:

- una buona pulizia, eliminando residui di calce, cemento e/o altro.
- È consigliabile peraltro proteggere il manufatto sino al momento della messa in esercizio, lubrificare con olio o grasso neutri le parti in movimento e gli organi di chiusura, controllare il corretto serraggio delle viti e dei grani, controllare gli assetti, registrandoli laddove sono previste regolazioni.

Si raccomanda di effettuare queste operazioni almeno con cadenza semestrale.

In caso di funzionamento anomalo di qualche componente, evitare assolutamente interventi atti a modificarne le caratteristiche e la sostituzione con ricambi non originali. Ci sembra utile ricordare che interventi di regolazione e/o sostituzione, con particolare riferimento ai meccanismi per oscillo-battente, andranno eseguiti da personale specializzato.

- Si raccomanda inoltre, in occasione delle operazioni di pulizia, di non utilizzare detersivi che possano deteriorare i trattamenti superficiali, escludendo tassativamente acidi, solventi, materiali abrasivi, spazzole metalliche o comunque in grado di scalfire le superfici, pagliette metalliche e altro.

WEIGHT OF PROFILES

The weight indicated is the theoretical one and may vary depending on the thickness and dimensional tolerances of the profiles (STANDARD UNI EN 12020-2)

EXTRUSION ALLOY

The profiles are made of extrusion alloy EN-AW-6060 (UNI EN 573/3)

DIMENSIONS OF PROFILES

The dimensions indicated are the theoretical ones; they may vary depending on the extrusion dimensional tolerances (STANDARD UNI EN 12020-2). This variability, which affects all the profiles, can affect, even if minimally, the cutting size and, therefore, the final size of the window. Also the coating, increasing the thickness, affects the size of the profiles and, in particular, reduces the space in the housing of window gaskets and accessories.

CUTTING AND TOOLING DIMENSIONS

The theoretical cutting and tooling sizes indicated in this catalogue are accurate, that is, they are mathematically correct. In practice, in some cases they may need to be adapted to take into consideration the precision and dimensional settings of the machines used. We therefore recommend that test samples be made in the first jobs or in the case of large quantities of windows.

SURFACE PROTECTION

The rules below should be followed to limit filiform corrosion phenomena:

- ◆ **Use aluminium assembly accessories**
- ◆ **Use stainless steel screws**
- ◆ **Use appropriate products to protect cut and tooled parts.**
- ◆ **Prevent condensation from accumulating inside the profiles.**

For the manufacture of windows and doors, it is necessary to adhere to the construction technology and use the original gaskets and accessories listed in the technical catalogue, in compliance with current standards, regulations and recommendations.

Compliance with the above determines the warranty.

On this basis, samples have been produced which, when tested in the laboratory, have obtained the results indicated in the certifications.

For the proper functioning and durability of the fixtures made with the system's profiles and accessories, it is necessary to carry out a few simple operations:

- thorough cleaning, removing any residues of lime, cement and/or other materials.
- It is also advisable to protect the product until it is put into service, lubricate the moving parts and closing mechanisms with neutral oil or grease, check that the screws and grub screws are tightened correctly, check the settings and adjust them where necessary.

It is recommended that these operations be carried out at least every six months.

In the event of abnormal operation of any component, avoid any intervention that could modify its characteristics and avoid replacing it with non-original spare parts. It is important to remember that any adjustment and/or replacement, with particular reference to tilt-and-turn mechanisms, must be carried out by specialised personnel.

- When cleaning, it is also recommended not to use detergents that could damage the surface treatments, strictly excluding acids, solvents, abrasive materials, metal brushes or anything else that could scratch the surfaces, metal scouring pads and so on.

**DIMENSIONS AND TYPE OF WINDOWS****DIMENSIONI E TIPOLOGIA DEI SERRAMENTI**

La valutazione delle dimensioni dei serramenti, richiede la considerazione di vari fattori quali: il momento d'inerzia dei profilati, le dimensioni e il peso dei tamponamenti (vetri-pannelli), la larghezza e l'altezza delle parti apribili, caratteristiche e portate degli accessori, le condizioni e le quantità degli ancoraggi alle opere morte, l'esposizione, ecc... Fattori che sono valutabili e applicabili, grazie alla buona conoscenza dello stato dell'arte, alle informazioni riportate dai cataloghi, manuali tecnici e dalle normative vigenti. Consigliamo, al fine di evitare inutili contestazioni, di consultare il nostro servizio tecnico sistemi, prima di realizzare serramenti che, per dimensione, forma, esposizione e/o altro possono essere ritenuti atipici. Le soluzioni e le combinazioni proposte in questo catalogo, non hanno carattere limitativo, ma presentano solo le situazioni e combinazioni più comunemente riscontrabili nella realtà.

Various factors must be taken into consideration when assessing the dimensions of the windows, such as: the moment of inertia of the profiles, the dimensions and weight of the panels (glass-panels), the width and height of the opening parts, the characteristics of the accessories, the condition and number of fastenings to the dead work, the exposure, etc. These factors can be assessed and applied, thanks to the good knowledge of the state of the art and to the information reported in catalogues, technical manuals and current regulations.

In order to avoid needless complaints, we invite you to contact our technical service before making windows that, due to their size, shape, exposure and/or other characteristic, could be considered non-standard. The solutions and combinations proposed in this catalogue are not the only ones available, but merely represent the most common situations and combinations.

COMPOSIZIONE PROFILATI

I profilati per serramenti saranno in lega di alluminio ENAW 6060 (EN 573-3 e EN 755-2) con stato fisico di fornitura UNI EN 515. I telai fissi e le ante mobili dovranno essere realizzati con profilati ad interruzione di ponte termico a tre camere (profilo interno ed esterno tubolari, collegati tra di loro con barrette in poliammide PA6.6 rinforzate con fibra di vetro).

INFISSI

Le finestre scorrevoli e le porte finestre scorrevoli dovranno avere un profilato di telaio fisso con profondità di mm.160 mm. ed un profilato di anta mobile con profondità minima 68 mm. I profilati di telaio fisso inferiore dovranno avere la possibilità di utilizzare un binario inox, riportato, per lo scorrimento facilitato e l'usura con conseguente sostituzione.

I profilati di telaio fisso dovranno essere predisposti, dove necessario, per ricevere alette di battuta interna sulla muratura da 25 mm. I profilati di ante mobili potranno contenere vetrazioni fino a 50 mm. Inoltre le finestre e porte scorrevoli avranno la possibilità di essere realizzate con 1 o più ante compresa la soluzione angolare.

ISOLAMENTO TERMICO

L'interruzione del ponte termico sarà ottenuta da barrette continue in poliammide da 28 mm., e da 14 mm. per le ante mobili, e dovrà garantire un valore di trasmittanza termica per l'infisso $U_w = \dots W/m^2K$. L'assemblaggio dei profilati in alluminio a taglio termico dovrà garantire i valori di scorrimento (T) tra profilati in alluminio e barrette in POLIAMMIDE previsti dalla direttiva tecnica Europea (UEAtc).

DRENAGGI E VENTILAZIONE

I profilati esterni delle ante mobili dovranno prevedere una gola ribassata per la raccolta delle acque di infiltrazione e di condensa onde poter permettere il libero deflusso delle stesse attraverso apposite asole di scarico. Le barrette in poliammide dovranno avere una conformazione geometrica atta ad evitare eventuale ristagno di acque di infiltrazione e di condensa ed essere perfettamente complanari con le pareti trasversali dei profilati di alluminio.

ACCESSORI DI ASSEMBLAGGIO

Le giunzioni tra profilati orizzontali e verticali dovranno essere perfettamente solidali e ben allineate tra di loro, sia nella parte esterna che interna dei profilati ed unite mediante apposite squadrette a bottone o, in alternativa, in alluminio estruso o pressofuso, con metodo a spino-cianfrinatura od a cianfrinatura totale. Le sezioni dei profilati orizzontali e verticali dovranno essere opportunamente sigillate prima di essere unite con le squadrette. I fermavetri saranno accoppiati a scatto posizionati nei canali dei profilati in alluminio.

GUARNIZIONI

Tutte le guarnizioni dovranno essere in elastomero (EPDM). LA continuità angolare sarà assicurata mediante l'impiego di angoli vulcanizzati preformati incollati alla stessa o in alternativa mediante telai vulcanizzati.

PRESTAZIONI

I serramenti dovranno avere prestazioni di permeabilità all'aria, tenuta all'acqua e resistenza ai carichi del vento conformemente alle norme: (UNI-EN 12207 - 12208 - 12210 e UNI-EN 1026 - 1027 - 12211)

PROFILES COMPOSITION

The window profiles are made of ENAW 6060 aluminum alloy (EN 573-3 and EN 755-2) with physical state of supply UNI EN 515. The fixed frames and sliding doors must be made with three-chamber thermal break profiles (tubular internal and external profile, connected to each other with glass fibre reinforced polyamide PA6.6 bars).

DOORS AND WINDOWS

The registered sliding doors and windows sash have a fixed frame profile with a depth of mm.120 mm. (alternatively mm. 60.3 for single-leaf and mm.179.7 for 3-leaf) and a mobile leaf profile with depth minimum 46 mm. The registered lower fixed frame profiles have the possibility of using a stainless steel rail, brought back, for easier sliding and wear with subsequent replacement. The registered fixed frame profiles must be prepared, where necessary, to have internal rebate fins on the 25 mm masonry. The profiles of mobile doors can contain glazing up to 50 mm. Furthermore, the windows and sliding doors will have the possibility of being made with 1 or more doors including the corner solution.

THERMAL BREAK

The interruption of the thermal bridge will be obtained by continuous 28 mm polyamide bars. for frames with snap technology, and 14 mm. for the mobile leaves, and must guarantee a thermal transmittance value for the frame $U_w = \dots W/m^2K$. The assembly of aluminum profiles with thermal break must guarantee the sliding values (T) between aluminum profiles and POLYAMIDE bars envisaged by the European technical directive (UEAtc).

DRAINAGE AND VENTILATION

The junctions between horizontal and vertical profiles must be perfectly integral and well aligned with each other, both in the external and internal part of the profiles and joined by means of special button brackets or, alternatively, in extruded or die-cast aluminum, with the pin-crimping method or with total crimping. The sections of the horizontal and vertical profiles must be properly sealed before being joined with the brackets. The glazing beads will be snap coupled and positioned in the channels of the aluminum profiles.

ASSEMBLY ACCESSORIES

The joints between the horizontal and vertical profiles must be perfectly united and correctly aligned with each other, both externally and internally and joined by means of special slot corner joints or, alternatively, in extruded or die-cast aluminum, with a dowel-crimping or full crimping method. The sections of the horizontal and vertical profiles must be properly sealed before being joined with the corner joints. The glazing beads will be snap-coupled and positioned in the channels of the aluminum profiles.

WINDOW GASKETS

All window gaskets will have to be made in elastomer (EPDM). SAll corner sealings will ensure continuity using preformed vulcanized corner joints glued to it or, alternatively, vulcanized frames.

PERFORMANCES

The windows and doors must have air permeability, water tightness and resistance to wind loads in accordance with the standards: (UNI-EN 12207 - 12208 - 12210 e UNI-EN 1026 - 1027 - 12211)

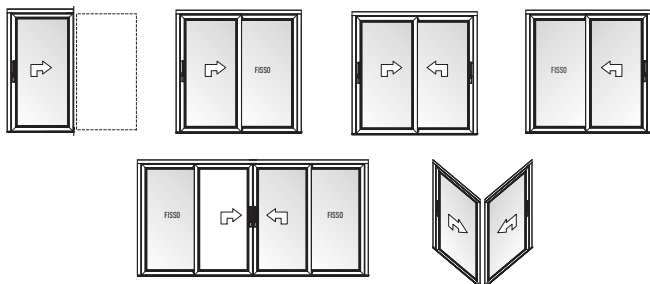
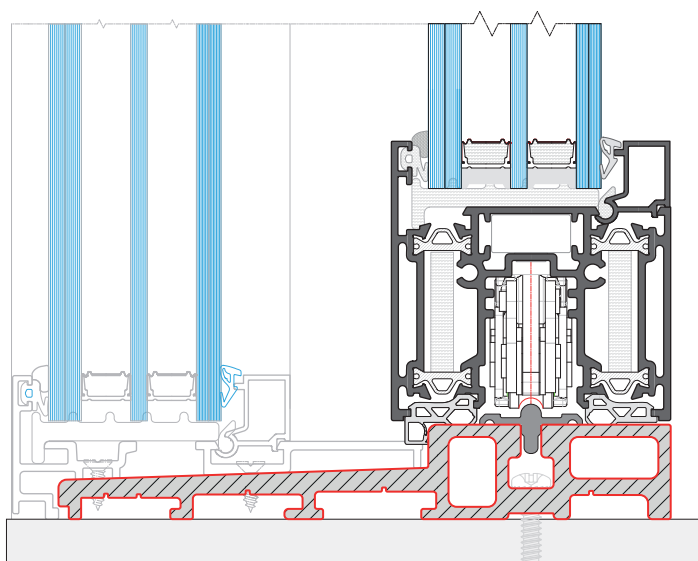

CARATTERISTICHE FISICHE

Profilati estrusi lega:

- ENAW 6060 (EN 573 - 3)

Stato di fornitura:

- T5 (EN 752 - 2)

Tolleranze dim. e spessori:

- EN 755 - 9

Tipo di tenuta aria/acqua:

- Con spazzolino / guarnizione speciale per scorrimento.

Inserimento del vetro :

- con Fermavetro

H utile alloggiamento vetro:

- mm. 16 Possibilità di inserimento volumi di vetro o pannelli con spessori variabili fino a mm. 55.

Impiego:

- Profilati per finestre e porte scorrevoli ad alto valore termico che consentono la costruzione di infissi ad una, due o più ante e soluzione angolare. Gli accessori del sistema HM 160 permettono la realizzazione di ante con peso di 400 kg.

PHYSICAL CHARACTERISTICS

Alloy extruded profiles:

- ENAW 6060 (EN 573 - 3)

Delivery State:

- T5 (EN 752 - 2)

Size and thickness tolerances:

- EN 755 - 9

Type of air/water seal:

- With brush / special sliding seal.

Glass insertion :

- Glassholder

H useful glass housing:

- mm. 16. Possibility of inserting glass volumes or panels with variable thicknesses up to mm. 55.

Use:

- Profiles for windows and sliding doors with high thermal value that allow the construction of fixtures with one, two or more wings and angular solution. The accessories of the HM 160 system allow the creation of doors with a weight of 400 kg.

CARATTERISTICHE FISICHE | PHYSICAL CHARACTERISTICS

- ♦ Telaio Fisso | Fixed Frame: _____ 160 x35 mm.
- ♦ Telaio Mobile | Window Frame: _____ 68 x 68 mm.
- ♦ Barrette Isolanti | Insulating Rods: _____ Poliammide Green
- ♦ Alloggiamento Accessori | Accessories Housing: _____ ad inserimento [insertion]
- ♦ Giunzione Angolare | Corner Joint: _squadrette [Corner Joints]

PRESTAZIONI CERTIFICATE | CERTIFIED PERFORMANCES

AAV

- ♦ Permeabilità all'aria | Air Permeability: _____ Classe 4
- ♦ Tenuta all'acqua | Watertightness: _____ Classe E750
- ♦ Carico di vento | Wind load resistance: _____ Classe C5
- ♦ Isolamento acustico | Sound Insulation: _____ 42dB
- ♦ Resistenza all'effrazione | Breakage resistance: _____ RC3

Risultati dei test / CE product pass conforme ad:

Tests Results / CE product pass Compliant with:
UNI EN 14351-1:2006+A1:2010

TRASMITTANZA TRANSMITTANCE

$U_w = 1.30 \text{ W/(m}^2\text{K)}$

SERRAMENTO CAMPIONE | SAMPLE FRAME

- ♦ Vetro Certificato | Certified Glass:
Doppio Vetro | Double Glazing $U_g = 1.0 \text{ W/(m}^2\text{K)}$
- ♦ Canalina | Duct: $\psi = 0.036 \text{ W/(m}^2\text{K)}$
- ♦ Finestra normalizzata | Normalized Window:
H = 2500 mm. ed L = 2720 mm.

$U_w = 0.98 \text{ W/(m}^2\text{K)}$

SERRAMENTO CAMPIONE | SAMPLE FRAME

- ♦ Vetro Certificato | Certified Glass:
Triplo Vetro | Triple Glazing $U_g = 0.6 \text{ W/(m}^2\text{K)}$
- ♦ Canalina | Duct: $\psi = 0.031 \text{ W/(m}^2\text{K)}$
- ♦ Finestra normalizzata | Normalized Window:
H = 2500 mm. ed L = 2720 mm.

• Dimensioni massime ammesse per il calcolo U_w su serramento campione fino a 2.3 m² (secondo norma UNI EN 14351-1:2006+A1:2010) +/- 25%

• Maximum allowable dimensions for calculation of the U_w on sample window frame up to 2.3 m² (according to UNI EN 14351-1:2006+A1:2010) +/- 25%

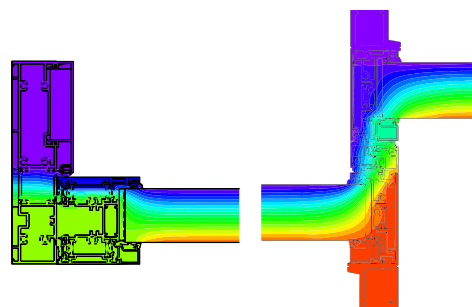

- Analisi termica con FLIXO vers.8 e WinIso2D Professional 7.8
- Thermicon FLIXO vers.8 e WinIso2D Professional 7.8



Tenuta all'Acqua
Watertightness



Capacità di un inso di impedire infiltrazioni quando è investito da un flusso d'acqua ed è presente una differente pressione tra interno ed esterno.
Capacity of a window to prevent infiltrations when impacted by a gush of water and there is a different internal and external pressure.

Press.	0 Pa	0 Pa	100 Pa	150 Pa	200 Pa	250 Pa	300 Pa	450 Pa	600 Pa	750 Pa	900 Pa	1050 Pa	1200 Pa	1350 Pa	1500 Pa
Velocità	03	24	55	56	47	27	89	6	111	126	138	149	159	169	178
Classe	-1	A2	A3	A4	A5	A6	A7	A8	A9	E750	E900	E1050	E1200	E1350	E1500

Pressure
Speed
Class

Classe | Class
E750
EN 1027 - EN 12208

L'infisso TWIN, con una pressione del vento pari ad una velocità di 126 Km/h (750 Pa) non ha avuto infiltrazioni
The frame TWIN with a wind pressure equal to a speed of 126 Km/h (750 Pa), had no infiltrations

Tenuta all'Aria
Air Permeability



Caratteristica di un inso chiuso di lasciare filtrare aria quando è presente una differenza di pressione tra l'interno e l'esterno; minori saranno i volumi dispersi, maggiore sarà la qualità del serramento.
Characteristic of a closed window to let air filter through when there is a different internal and external pressure; the lower the dispersed volumes, the higher the quality of the frame.

Press.	150Pa	300Pa	450Pa	600Pa	Pressure
Classe	1	2	3	4	Class

L'infisso TWIN ha superato la prova con Pressione Vento = 111 k/h (600Pa)
The frame TWIN has passed the test with a Wind Pressure = 111 Km/h (600Pa)

Classe | Class
4
EN 1026 - EN 12207

Resist. al Vento
Wind Resistance



Capacità di un inso sottoposto a forti pressioni e/o depressioni, come quelle causate dal vento, di mantenere una deformazione ammissibile, di conservare le proprietà iniziali a salvaguardia della sicurezza degli utenti.
Capacity of a window subject to high positive and/or negative pressures, like that caused by the wind, to maintain an admissible deformation, to conserve its initial properties and to safeguard users against breakage.

Press.	400Pa	800Pa	1200Pa	1600Pa	2000Pa	>2000Pa	Pressure
Flessione	A (≤ 1/150)	B (≤ 1/200)	C (≤ 1/300)				Flexure
Classe	12	34	5E	xxx			Class

Classe | Class
C5
EN 12211-EN 12210

* Serramento a 2 ante, dimensione L = mm.2400 ed H = mm.2195 - Certificato n° 1994-CPR-RP2815 (Altre Certificazioni Disponibili)
Double Casement window, dimension L = mm.2400 ed H = mm.2195 - Test certificate no. RP no. 1994-CPR-RP2815 (Other certifications available).

Fonoisolamento
Sound Insulation



Perdita di isolamento acustico rispetto al vetro DR_w (dB) a partire dalla classe di permeabilità all'aria dell'infisso (UNI EN 12207)
Capacity of a window to resist violent intrusion following the application of a physical force or with the aid of tools.

Classe	1	2	3	4	Class
Perdita	8dB	6dB	4dB	2dB	DR _w ≤38 dB

Amnesso l'utilizzo di questo metodo tabellare
Admitted This table method

DR_w>39 dB Necessario realizzare un campione al vero e sottoporre a prove di Laboratorio.
An actual sample must be made and tested in the laboratory.

Abbattimento Acustico
Noise Reduction
42 dB
EN ISO140-3 | 717-1

Trasmittanza
Transmittance



Flusso di calore che passa attraverso il serramento per m2 di superficie e per ogni grado di differenza di temperatura tra interno ed esterno.
Flow of heat that passes through the window per m2 of surface and for every degree of difference in temperature between outdoors and indoors.

U_w	1,30 W/m²K
	Finestra a 2 ante normalizzata (2500 mm. x 2720 mm; vetro doppio U _g =1.0 W/m²K certificato con canalina psi=0.036 W/m²K) Normalised 2 Sashes window (2500 mm x 2720 mm; double glazing U _g =1.0 W/m²K certified with duct psi=0.036 W/m²K)
U_w	0,98 W/m²K
	Finestra a 2 ante normalizzata (2500 mm. x 2720 mm; vetro Triplo U _g =0.6 W/m²K certificato con canalina psi=0.031 W/m²K) Normalised 2 Sashes window (2500 mm x 2720 mm; triple glazing U _g =0.6 W/m²K certified with duct psi=0.031 W/m²K)

Antieffrazione
Breakage Resistance



Capacità di un infisso di resistere ad un'intrusione violenta a seguito di una applicazione di una forza fisica e con l'aiuto di attrezzi
Finestra a 2 ante (2400 mm. x 2195 mm) - CERTIFICATO 0818-RP-2025
Capacity of a window to resist violent intrusion following the application of a physical force or with the aid of tools.
2 sashes window (2400 mm x 2195 mm) - 0818-RP-2025 CERTIFIED door

Classe	RC1	RC2	RC3
Intrusione	Forza Fisica (Calci Pugni, Spallate)	Semplice Attrezzatura (Cunei, Cacciaviti)	R2 + Piede di Porco
Intrusion	Physical strength (kicks, pushing, pushing with shoulder)	Simple Tools (Wedges, Screwdrivers)	R2 + Crowbar

L'infisso TWIN, resiste in modo efficace ai tentativi di intrusione interna.
The TWIN window effectively resists attempted breakins

Resistenza Effrazione
Breakage Resistance
RC3

**LA MARCATURA CE DELLE FINESTRE E PORTE PEDONALI**
[Senza caratteristiche di resistenza al fuoco e/o di tenuta al fumo]

Il marchio CE, apposto sui prodotti da costruzione, attesta la loro conformità ai requisiti essenziali definiti dalla direttiva 89/106/CE "Prodotti da costruzione", emanata dal Consiglio della Comunità Europea il 21/12/1988 ed attuata, in Italia, dal D.P.R. n. 246 del 21/04/1993. La marcatura CE di uno specifico prodotto da costruzione diviene obbligatoria, al fine di immettere il prodotto in un mercato della Comunità Europea, allorché sia stata emessa dal CEN, su mandato della Comunità Europea, una "specificazione tecnica" (norma o benessere tecnico) che regolamenti la sua applicazione.

La responsabilità per la verifica dei requisiti del prodotto e per l'apposizione della marcatura CE spetta al suo fabbricante. Al fine di garantire i requisiti richiesti dalle relative norme, il fabbricante è tenuto a:

- ◆ **Predisporre un piano di controllo della produzione (FPC). E' un sistema di procedure e controlli da eseguire durante le fasi di produzione**
- ◆ **Effettuare delle "prove iniziali di tipo" (ITT) sul prodotto al fine di determinare le prestazioni. Le modalità di prova dei requisiti del prodotto sono definite dalle norme richiamate dalla specifica norma prodotto".**

Alcune prove possono essere eseguite dal produttore stesso, secondo le disposizioni delle relative norme armonizzate, mentre altri requisiti sono di competenza di laboratori in possesso di una notifica attribuita loro dallo stato membro di appartenenza (organismi notificati).

IL FABBRICANTE PUO' PROCEDERE IN PIU' MODI

- ◆ **Eseguire autonomamente i test sui propri prodotti presso un istituto Notificato, diventando quindi titolare degli ITT**
- ◆ **Far riferimento ai risultati di prove effettuate dal detentore del sistema di serramento, purché quest'ultimo abbia espresso il proprio consenso per mezzo di un contratto di licenza d'uso stipulato tra le parti.**

Da Febbraio 2010 è obbligatoria la marcatura CE per finestre e porte pedonabili senza caratteristiche di resistenza al fuoco e tenuta al fumo.

L'appendice ZA della norma UNI EN 14351-1 specifica le caratteristiche essenziali per finestre e porte e attribuisce le competenze delle prove iniziali di tipo.

Il requisito relativo ad una determinata caratteristica non è applicabile in quegli Stati Membri nei quali non sussistono requisiti di regolamentazione per tale caratteristica per l'impiego previsto del prodotto. In questo caso, i fabbricanti che immettono i loro prodotti sul mercato di questi Stati membri non sono obbligati a determinare né a dichiarare le prestazioni dei loro prodotti in relazione a questa caratteristica e può essere utilizzata l'opzione "Nessuna Prestazione Determinata" (NPD) nelle informazioni che accompagnano la marcatura CE (vedere punto ZA.3). Tuttavia, l'opzione NPD non può essere utilizzata nel caso in cui la caratteristica sia soggetta a un livello soglia. (Citazione integrale tratta dalla norma UNI EN 14351-1 - appendice ZA)

CE MARKING OF PEDESTRIAN WINDOWS AND DOORS
[Without fire resistance and/or smoke resistance characteristics]

The CE marking, affixed to products, certifies their compliance with the essential requirements of Directive 89/106/EC "Construction products", issued by the Council of the European Community on 21/12/1988 and implemented, in Italy, by Presidential Decree no. 246 of 21/04/1993. The CE marking of a specific product is mandatory when the product is to be placed on a European Community market, whenever a "technical specification" (standard or technical approval) that regulates its application has been issued by CEN, under mandate of the European Community.

The manufacturer is responsible for verifying product requirements and affixing the CE marking. To ensure fulfilment of the requirements of the relevant standards, the manufacturer must:

- ◆ *Draw up a production control plan (PCP). This system of procedures and controls are performed during the production stages.*
- ◆ *Carry out "initial type tests" (ITT) on the product in order to determine performance. The test methods of the product requirements are defined by the standards referred to in the specific product standard ".*

Some tests can be carried out by the manufacturer, in accordance with the provisions of the relevant harmonised standards, while others are the responsibility of laboratories awarded notified body status by their Member State (notified bodies).

THE MANUFACTURER MAY PROCEED IN SEVERAL WAYS:

- ◆ *Carry out the tests on its products independently at a Notified Body, thus becoming the holder of the ITTs*
- ◆ *Refer to the results of tests carried out by the holder of the window and door system, provided that the latter has given his consent by means of a user licence agreement signed by the parties.*

From February 2010, CE marking is mandatory for pedestrian windows and doors without fire resistance and smoke resistance characteristics. Appendix ZA of standard UNI EN 14351-1 specifies the essential characteristics for windows and doors and attributes responsibilities for the initial type tests.

The requirement for a given characteristic does not apply in the Member States where there are no regulatory requirements for that characteristic for the intended use of the product. In this case, manufacturers who place their products on the market of these Member States shall not be obliged to determine or to declare the performance of their products for same characteristic and the "No Performance Determined" (NPD) option may be used in the information accompanying the CE marking (see point ZA.3). However, the NPD option cannot be used when the characteristic is subject to a threshold level. (Full quote from UNI EN 14351-1 - Appendix ZA)



Per finestre e porte senza funzione di compartimentazione del fuoco o fumo e non poste nelle vie di fuga (sistema di attestazione della conformità 3):

For windows and doors without a fire or smoke compartmentalization function and not located in run off areas (conformity attestation system 3):

CARATTERISTICHE FONDAMENTALI FUNDAMENTAL CHARACTERISTICS	Espressioni di Prestazione Expressions of Performance	Competenze Prove Iniziali Tipo Initial Type Test Responsibilities		
		ON= Organismo Notificato; PR= Produttore ON=Notified Body; PR= Manufacturer		
		Finestre Windows	Porte Doors	Lucernari Hopper Windows
Comportamento al FUOCO Dall'Esterno <i>External Fire Behaviour</i>				ON
Resistenza al FUOCO <i>Fire Reaction</i>	Euroclassi <i>Euroclasses</i>			ON
Tenuta all'ACQUA <i>Watertightness</i>	Classi Tecniche <i>Technical Classes</i>	ON	ON	ON
Sostanze Pericolose <i>Hazardous Substances</i>		ON	ON	
Resistenza al Carico del VENTO <i>Wind Load Resistance</i>	Classi Tecniche <i>Technical Classes</i>	ON	ON	PR
Resistenza al Carico della NEVE e Carico Permanente <i>Snow Load and Permenent Load</i>	Classi Tecniche <i>Technical Classes</i>			PR
Resistenza all'URTO <i>Shock Resistance</i>	KN/m² <i>KN/sqm</i>		PR	ON
Capacità Portante dei Dispositivi di Sicurezza <i>Load-bearing Capacity of Savety evices</i>	Soglia	ON	ON	ON
Altezza <i>Height</i>	mm.		PR	
Forze di azionamento (solo dispositivi automatici) <i>Operating forces (automatic devices only)</i>	Classi Tecniche <i>Technical Classes</i>		ON	
Prestazione acustica <i>Acoustic Performance</i>	dB	ON	ON	ON
Trasmittanza termica <i>Heat Transmittance</i>	W/m²K	ON	ON	ON
Proprietà radioattive <i>Radioactive properties</i>				PR
Permeabilità all'ARIA <i>AIR Permeability</i>	Classi Tecniche <i>Technical Classes</i>	ON	ON	PR

La valutazione delle caratteristiche da dichiarare è funzione della destinazione d'uso del prodotto e della legislazione vigente nello Stato Membro, ove esso è immesso.

The characteristics to be declared depend on the intended use of the product and the legislation in force in the Member State where it is sold.



TEST INIZIALI di TIPO (ITT)

La serie riportata nel presente catalogo è stata sottoposta a test iniziali di tipo (ITT) relativamente ai requisiti previsti dalla norma prodotto UNI EN 14351-1.

I risultati dei test iniziali di tipo sono estendibili a serramenti di differente tipologia e con differenti dimensioni e componenti, secondo le indicazioni fornite dalla norma EN 14351-1 in Appendice A (interdipendenza fra le caratteristiche e i componenti), Appendice E (determinazione delle caratteristiche) ed Appendice F (selezione facoltativa di provini rappresentativi per le finestre)

Il costruttore di serramenti ha la responsabilità di verificare la rispondenza del serramento prodotto rispetto al campione sottoposto a prova. Il consorzio TWIN Systems mette a disposizione dei propri clienti i risultati dei test effettuati, a seguito della stipulazione di un contratto d'uso gratuito degli stessi.

Dichiarazione di Conformità

Il fabbricante del serramento è tenuto a consegnare al committente una dichiarazione di conformità la quale, in accordo alla norma UNI EN 14351-1, deve includere :

- ◆ **Nome ed indirizzo del fabbricante o del suo rappresentante autorizzato con sede nella EEA;**
- ◆ **Descrizione del prodotto (tipo, identificazione, impiego, ecc.) e una copia delle informazioni che accompagnano la marcatura CE;**
- ◆ **Disposizioni alle quali il prodotto è conforme (appendice AZ della norma prodotto UNI EN 14351-1);**
- ◆ **Condizioni particolari applicabili all'impiego del prodotto (per esempio disposizioni per l'impiego in determinante condizioni, ecc.);**
- ◆ **Nome e indirizzo del/i laboratorio/i approvato/i.**
- ◆ **Nome e qualifica della persona incaricata di firmare la dichiarazione per conto del fabbricante o del suo rappresentante autorizzato.**

La dichiarazione e il certificato devono essere presentati nella lingua o nelle lingue ufficiali dello Stato Membro in cui il prodotto deve essere utilizzato.

Etichettatura e Marcatura

Il fabbricante deve fornire informazioni sufficienti ad assicurare la rintracciabilità del suo prodotto fornendo il collegamento fra il prodotto, il fabbricante e la produzione. Queste informazioni devono essere contenute su un'etichetta o specificate in documenti di accompagnamento nelle specifiche tecniche pubblicate dal fabbricante. Le informazioni seguenti devono accompagnare il simbolo di marcatura CE:

- ◆ **Nome e indirizzo registrato o marchio di identificazione del fabbricante;**
- ◆ **Ultime due cifre dell'anno in cui la marcatura CE è stata applicata;**
- ◆ **Riferimento alla norma di prodotto (EN 14351-1);**
- ◆ **Descrizione del prodotto: nome generico, materiale, dimensioni, ecc. e impiego previsto;**
- ◆ **Informazioni sulle caratteristiche essenziali che devono essere dichiarate presentate come:**
- ◆ **Valori dichiarati o livelli e/o classi;**
- ◆ **NPD - " Nessuna prestazione determinata" per le caratteristiche quando è pertinente.**

INITIAL TYPE TESTS (ITT)

The series in this catalogue has been subjected to initial type tests (ITT) for the requirements of product standard UNI EN 14351-1. The results of the initial type tests can be extended to doors and windows of different types and of different sizes and compositions, according to the indications provided for by EN 14351-1 in Appendix A (interdependence between the characteristics and compositions), Appendix E (determination of characteristics) and Appendix F (optional selection of representative samples for the windows).

The door and window manufacturer is responsible for verifying compliance of the window with the sample under test. The TWIN Systems consortium makes the results of the test performed available to its customer, after the free usage agreement has been signed.

Declaration of Conformity

The window and door manufacturer must provide the customer with a declaration of conformity which, in accordance with UNI EN 14351-1, must include:

- ◆ **Name and address of the manufacturer or its authorised representative established in the EEA;**
- ◆ **Description of the product (type, identification, use, etc.) and a copy of the information accompanying the CE marking;**
- ◆ **Provisions with which the product complies (Appendix AZ of product standard UNI EN 14351-1);**
- ◆ **Special conditions applicable to the use of the product (e.g. provisions for use under certain conditions, etc.);**
- ◆ **Name and address of the approved laboratory(ies).**
- ◆ **Name and capacity of the person empowered to sign the declaration on behalf of the manufacturer or his authorised representative.**

The declaration and certificate must be done in the official language or languages of the Member State where the product is to be used.

Labelling and Marking

The manufacturer must provide sufficient information to ensure the traceability of the product providing the link between the product, the manufacturer and the production. This information must be contained on a label or specified in accompanying documents in the technical specifications published by the manufacturer. The following information must accompany the CE marking symbol:

- ◆ **Manufacturer's name and registered address or identification mark;**
- ◆ **Last two digits of the year in which the CE marking was applied;**
- ◆ **Reference to the product standard (EN 14351-1);**
- ◆ **Description of the product: generic name, material, size, etc. and intended use; Information about the essential characteristics that must be declared: Declared values or levels and/or classes;**
- ◆ **NPD - " No Performance Determined" for characteristics when relevant.**



Il simbolo della marcatura CE e le informazioni di accompagnamento devono essere apposti in modo visibile, leggibile e indelebile in una o più delle posizioni seguenti (gerarchia di preferenza del fabbricante):

Qualsiasi parte idonea del prodotto stesso, purché sia assicurata la visibilità quando si aprono le ante; Su un'etichetta attaccata; Sul suo imballaggio; Sul documento commerciale di accompagnamento.

DOCUMENTAZIONE TECNICA DI ACCOMPAGNAMENTO

Il fabbricante deve fornire informazioni su quanto segue:

- *Immagazzinaggio e movimentazione, se il fabbricante non è responsabile dell'installazione del prodotto;*
- *Requisiti e tecniche d'installazione (sul posto), se il fabbricante non è responsabile dell'installazione del prodotto (Guida UNCSAAL)*
- *Manutenzione e pulizia (Manuale Consorzio TWIN SYSTEMS)*
- *Istruzioni d'uso finali incluse le istruzioni per la sostituzione di componenti*
- *Istruzioni per l'uso in condizioni di sicurezza.*

In Italia i requisiti obbligatori per la Marcatura CE sono:

- *Permeabilità dell'aria*
- *Trasmittanza termica*
- *Proprietà radiative (Fattore solare g, Trasmissione luminosa (TV))*

In Spagna e in Portogallo i requisiti obbligatori per la Marcatura CE sono:

- *Permeabilità all'aria*
- *Tenuta all'acqua*
- *Resistenza al vento*
- *Trasmittanza termica*
- *Isolamento acustico*

The CE marking and accompanying information must be affixed in a visible, legible and indelible way in one or more of the following positions (manufacturer's hierarchy of preference):

Any suitable part of the product itself, provided that visibility is ensured when opening the doors; On an attached label; On its packaging; On the accompanying commercial document.

ACCOMPANYING TECHNICAL DOCUMENTATION

The manufacturer will provide information about:

- *Storage and handling, if the manufacturer is not responsible for the installation of the product*
- *Requirements and installation methods (on site), if the manufacturer is not responsible for the installation of the product (UNCSAAL Guide)*
- *Maintenance and cleaning (TWIN SYSTEMS Consortium Manual)*
- *Final instructions for use including instructions for replacing components; Instructions for safe use.*

In Italy, the mandatory requirements for CE marking are:

- *Air permeability*
- *Heat Transmittance*
- *Radiative properties (Solar factor g, Light transmission (TV)).*

In Spain and Portugal the mandatory requirements for CE marking are :

- *Air permeability*
- *Watertightnes*
- *Wind resistance*
- *Heat Transmittance*
- *Sound insulation*



TRASMITTANZA TERMICA DEI SERRAMENTI

HEAT TRANSMISSION OF WINDOWS

E' necessario sapere che le prescrizioni dettate dal decreto ministeriale cambiano in funzione della tipologia di intervento edilizio (nuova costruzione, ristrutturazione importante di primo oppure secondo livello, riqualificazione energetica) e si applicano ad edifici sia pubblici sia privati.

Per edifici di nuova costruzione si intendono quei fabbricati il cui titolo abilitativo sia stato richiesto dopo l'entrata in vigore del decreto.

Sono assimilati agli edifici di nuova costruzione gli edifici sottoposti a demolizione e ricostruzione, qualunque sia il titolo abilitativo necessario, e gli ampliamenti di edifici esistenti la cui nuova porzione abbia un volume lordo climatizzato superiore al 15% di quello esistente o comunque superiore a 500 m³.

Per interventi di ristrutturazione importante di primo livello si intendono quelli che interessano l'involucro edilizio con un'incidenza superiore al 50 per cento della superficie disperdente lorda complessiva dell'edificio, comprendendo anche la ristrutturazione dell'impianto termico per il servizio di climatizzazione invernale e/o estiva asservito all'intero edificio.

Per interventi di ristrutturazione importante di secondo livello si intendono quelli che interessano l'involucro edilizio con un incidenza superiore al 25 per cento della superficie disperdente lorda complessiva dell'edificio e possono interessare l'impianto termico per il servizio di climatizzazione invernale e/o estiva.

Negli interventi di riqualificazione energetica rientrano gli interventi non riconducibili agli interventi succitati e che hanno un impatto sulla prestazione energetica dell'edificio. Rientrano quindi anche:

- Le ristrutturazioni che interessano l'involucro edilizio con un incidenza inferiore o uguale al 25% della superficie disperdente lorda complessiva dell'edificio e/o consistono nella nuova installazione, nella ristrutturazione di un impianto termico asservito all'edificio o di altri interventi parziali, ivi compresa la sostituzione del generatore;

- Gli ampliamenti di edifici esistenti la cui nuova porzione abbia un volume lordo climatizzato inferiore o uguale al 15% di quello esistente o comunque inferiore a 500 m³.

Per gli edifici di nuova costruzione e per quelli sottoposti a ristrutturazioni di primo livello, non sono previsti specifici limiti di trasmittanza termica da rispettare per le chiusure trasparenti. Sussiste l'obbligo di rispettare limiti per quanto concerne altri parametri tecnici che connotano gli impianti, l'involucro edilizio e l'edificio nel loro complesso (per esempio coefficiente medio globale di scambio termico per trasmissione per unità di superficie disperdente HT^{*} - area solare equivalente estiva per unità di superficie utile Asol,est/Asup utile - indice di prestazione termica utile per riscaldamento EPH,nd - indice di prestazione termica utile per il raffrescamento EPC,nd - indice di prestazione energetica globale dell'edificio EPgl,tot, ecc.) contenuti nell'Allegato A del decreto

Note that the requirements as of the ministerial decree depend on the type of construction (new construction, major first or second level renovation, energy upgrading) and apply to both public and private buildings.

New buildings are those whose building permit has been requested following the promulgation of the decree.

Buildings subject to demolition and reconstruction, irrespective of the type of building permit, and extensions to existing buildings whose new portion has a gross air-conditioned volume of more than 15% of the existing one or in any case more than 500 m³ are considered new buildings.

Major first level renovations are those affecting the building shell with an impact of more than 50% of the building's total gross dispersant surface, also including the renovation of the heating system for the winter and/or summer air conditioning service of the entire building.

For major second-level renovation interventions, those that concern the building shell with an impact of more than 25 percent of the building's total gross dispersant surface and can regard the heating plant system for the winter and/or summer air conditioning service.

Energy upgrading works include activities that are not attributable to the aforementioned activities and that have an impact on the building's energy performance. The following are therefore also included:

- Renovations that affect the building shell with an impact of less than or equal to 25% of the building's total gross dispersant surface and/or the new installation or upgrading of the building's heating plant or other partial works, including the replacement of the generator;
- Extensions of existing buildings whose new portion has a gross air-conditioned volume of less than or equal to 15% of the existing one or in any case less than 500 m³.

For new buildings and buildings undergoing first level renovations, there are no specific heat transmission limits to be respected for transparent doors. There is an obligation to respect the limits of other technical parameters that characterise the plants, shell and building as a whole (for example, average overall heat exchange coefficient for transmission by dispersant surface unit HT^{} - equivalent summer solar area per unit of surface area Asol,est/Asup - useful heat performance index for heating EPH,nd - heat performance index for cooling EPC,nd - overall energy performance index of the building EPgl,tot, etc.) contained in Annex A of the decree*



I limiti dell'Allegato A sul coefficiente medio globale di scambio termico per trasmissione per unità di superficie disperdente HT' sono da rispettare anche per gli interventi di ristrutturazione importante di secondo livello.

Nell'ambito degli interventi di ristrutturazione importante di secondo livello e degli interventi di riqualificazione energetica sono invece da rispettare i limiti riportati nell'Appendice B del decreto relativamente:

- Alla trasmittanza termica U_w dei serramenti (trasparenti, opachi) e dei cassonetti posti a delimitazione di ambienti climatizzati verso l'esterno oppure verso ambienti non climatizzati (cfr. tabella 1);
- Al fattore di trasmissione solare totale g_{gl+sh} dei serramenti vetrati in combinazione con schermature solari mobili posizionati sui fronti dell'edificio SUD, EST, OVEST, SUD-EST, SUD-OVEST (cfr. tabella 2).







The limits of Annex A on the overall average coefficient of heat exchange through transmission by unit of dispersant surface HT' must also be respected for major second-level renovations.

In the case of major second level renovations and energy upgrading works, the limits set out in Appendix B of the decree must be respected for:

- Heat transmission U_w of the windows (transparent, opaque) and shutter boxes positioned to delimit air-conditioned environments towards the outside or towards non-conditioned environments (see table 1);
- The total solar transmission factor g_{gl+sh} glazed windows in combination with mobile solar shields positioned on the SOUTH, EAST, WEST, SOUTH-EAST, SOUTH-WEST building façades (see table 2).

Tabella/Table 1

Valori limite della trasmittanza U_w dei serramenti (trasparenti, opachi) e dei cassonetti posti a delimitazione di ambienti climatizzati verso l'esterno oppure verso ambienti non climatizzati.

ZONA CLIMATICA	U_w [W/m ² K]	
	2021	ECOBONUS
 Zona A	3.00	2.60
 Zona B	3.00	2.60
 Zona C	2.00	1.75
 Zona D	1.80	1.67
 Zona E	1.40	1.30
 Zona F	1.00	1.00

Tabella/Table 2

Valori limite del fattore di trasmissione solare totale g_{gl+sh} chiusure trasparenti in presenza di schermature solari mobili installate su fronti dell'edificio SUD, EST, OVEST, SUD-EST, SUD-OVEST

ZONA CLIMATICA CLIMATIC ZONE	g_{gl+sh}
	2021
Zone TUTTE ALL ZONES	0.35



VALUTAZIONE DELLA PRESTAZIONE TERMICA DEI SERRAMENTI

TRASMITTANZA TERMICA:

La trasmittanza termica rappresenta il parametro più significativo per la valutazione del comportamento termico di un prodotto edilizio: minore è il suo valore migliore è la prestazione termica posseduta dal componente stesso.

Il calcolo semplificato della trasmittanza termica del componente finestrato U_w composta da un singolo serramento e relativo vetro (o pannello) si esegue con la formula:

VALUTAZIONE DELLA PRESTAZIONE TERMICA DEI SERRAMENTI

HEAT TRANSMISSION:

Heat transmission is the most significant factor in the evaluation of the thermal performance of a building product: the lower its value, the higher the thermal performance of the product.

The simplified heat transmission calculation of the product glazing U_w comprising a single window and related glass (or panel) the formula is:

$$U_w = \frac{A_g U_g + A_f U_f + l_g \emptyset_g}{A_g + A_f}$$

- A_g : Area del vetro in m^2
 - U_g : Trasmittanza termica riferito all'area centrale della vetrata, e non include l'effetto del distanziatore del vetro lungo il bordo della vetrata stessa
 - A_f : Area del telaio
 - U_f : Trasmittanza termica del telaio applicabile in assenza della vetrata
 - l_g : Lunghezza del perimetro del vetro
 - \emptyset_g : Trasmittanza termica lineare concernente la conduzione di calore supplementare che avviene a causa dell'interazione tra telaio, vetri e distanziatore dei vetri in funzione delle proprietà termiche di ognuno di questi componenti e si rileva, secondo quanto precisato nell'allegato E della norma UNI EN ISO 10077-1, preferibilmente con il calcolo numerico eseguito in accordo con la norma ISO 10077-2; quando non sono disponibili i risultati di calcolo dettagliati ci si può riferire ai prospetti E.1 ed E.2 i quali indicano i valori \emptyset_g di default per le tipiche combinazioni di telai, vetri e distanziatori.
-
- A_g : Area of the glass in m^2
 - U_g : Heat transmission of the central area of the window, not including the effect of the glass spacer along the edge of the window
 - A_f : Frame area
 - U_f : Heat transmission of the frame applicable in absence of the glass
 - l_g : Length of the perimeter of the glass
 - \emptyset_g : Linear heat transmission concerning the additional heat conduction that occurs due to the interaction between the frame, glass and spacer of the glass as a function of the thermal properties of each of these components and it is noted, as specified in Annex E of standard UNI EN ISO 10077-1, preferably with the numerical calculation performed in accordance with ISO 10077-2; when the detailed calculation results are not available you can refer to the default \emptyset for the typical combinations of frames, glass and spacers.

ESTENDIBILITÀ

L'appendice F della norma di prodotto UNI EN 14351-1 suggerisce le tipologie di serramento rappresentative e le relative estensioni, ma essendo la tabella puramente informativa, sta allo stesso produttore scegliere i campioni.

EXTENSIBILITY

Appendix F of the product standard UNI EN 14351-1 suggests the types of typical windows and their extensions, but since the table is purely informative, it is up to the manufacturer to choose the samples.

TIPO DI FINESTRA WINDOW TYPE	POSSIBILE ESTENSIONE Possible Extension
Anta FISSA <i>Fixed</i>	Finestra Battente/Ribalta <i>Tilt & Turn Window</i>
Porta Finestra ad Anta Singola (Apertura Interna o Esterna) <i>Single door window (internal or external opening)</i>	
Finestra Anta Singola con Ribalta <i>Single Sash Tilt & Turn Window</i>	
Finestra con DUE o più Porte (Apertura Interna o Esterna) <i>Window with two or more doors (internal or external opening)</i>	Stessa Tipologia <i>Same Type</i>
Finestra a UNA o DUE ante orizzontali scorrevoli <i>Window with ONE or TWO horizontal sliding sashes</i>	
Finestra con DUE Ante Scorrevoli <i>Window with TWO Sliding Sashes</i>	Stessa Tipologia <i>Same Type</i>
Finestra a UNA o DUE ante orizzontali scorrevoli con Ribalta <i>Window with ONE or TWO horizontal sliding sashes with Tilt & Turn</i>	Stessa Tipologia <i>Same Type</i>
Bilico Orizzontale o Verticale <i>Horizontal or vertical pivoting window</i>	Stessa Tipologia <i>Same Type</i>
Finestra a Soffietto <i>Folding Window</i>	Stessa Tipologia <i>Same Type</i>

La norma UNI EN 14351-1 prevede che il calcolo effettuato su di un serramento aventi dimensioni:

1230 (±25%) x 1480 (-25%)
1480 (+25%) x 2180 (±25%)

Le analisi termiche effettuate con le misure sopra descritte, possono essere estese a tutti i serramenti di tutte le dimensioni, purché il vetro utilizzato abbia come valore di U_g uguale o inferiore a 1.9 w/m²K, altrimenti la norma delle regole di estensione dei valori calcolati sull'infisso normalizzato ad infissi di diverse dimensioni.

Ovviamente i calcoli devono essere effettuati sulle stesse tipologie di infissi, e s'intende che una modifica del componente modifica la caratteristica in questione. In termini di prestazioni termiche è ovvio che andando a togliere o ad aggiungere elementi (per esempio passare da una finestra ad una anta, da una a due e così via), determina un variazione dei valori finali.

The UNI EN 14351-1 standard sets forth the calculation carried out on a window with dimensions:

1230 (±25%) x 1480 (-25%)
1480 (+25%) x 2180 (±25%)

The thermal analyses carried out with the measurements described above can be extended to doors and windows of all sizes, provided that the glass used has a U_g value equal to or less than 1.9 w/m²K, otherwise the standard of the rules of the values calculated on the normalised frame is extended to frames of different sizes.

Obviously, the calculations must be carried out on the same types of frames, and it is understood that any modification to the component changes the characteristic in question. In terms of thermal performance, it is clear that, removing or adding elements (for example, switching from a window with one door to one with two doors, and so on) results in a change in the final values.



POSA QUALITÀ

IL MARCHIO

Il Marchio Posa Qualità Serramenti distinguerà i migliori costruttori italiani di serramenti di tutti i materiali, offrendo ai consumatori italiani uno strumento tangibile per distinguere le migliori aziende con una garanzia assicurativa post vendita sul prodotto installato fino a 10 anni.

In questo modo il costruttore di serramenti potrà qualificare al cliente non solo le prestazioni «astratte» di un serramento, bensì quelle reali, una volta installato, potrà attestare la qualificazione della propria Azienda e potrà garantire nel tempo ciò che ha venduto. Perché un Marchio rigoroso sulla Posa è l'unica forma di garanzia tangibile da offrire al consumatore.

Il progetto Marchi Posa Qualità prevede un piano di formazione che coinvolgerà tutta la filiera industriale del serramento, un Marchio che certificherà la qualità della progettazione della posa attraverso severi test di laboratorio e un Marchio che garantirà e verificherà la sua corretta esecuzione attraverso controlli a campione.

il consorzio TWIN SYSTEMS è certificato PROGETTAZIONE Posa Qualità Serramenti dal 2020. I suoi consorziati organizzano periodicamente corsi professionali per l'acquisizione dei patentini professionali per i posatori.



POSA QUALITÀ

THE TRADEMARK

The Posa Qualità Serramenti Trademark identifies the best Italian manufacturers of windows and doors in all materials, offering Italian consumers a tangible way of identifying the best companies with an after-sales warranty on the installed product of up to 10 years.

In this way, the window manufacturer will be able to offer the customer not only a guaranteed "generic" good performance of the window, but real guarantees and, once installed, it will be able to attest the quality of the company and guarantee the products sold over time. Because guaranteed good installation is the only way offering customers peace of mind.

The Posa Qualità Brands project includes a training plan that will involve the entire window supply chain, a Brand that will certify the quality of the installation by means of strict laboratory tests and guarantee correct installation through spot checks.

The TWIN SYSTEMS Consortium has been certified Posa Qualità Serramenti DESIGN since 2020. The consortium members organise periodic training courses for installers with the award of professional licenses.

MANUALE e CATALOGO PRODOTTI TWIN SYSTEMS POSA QUALITÀ



IL MANUALE e CATALOGO PRODOTTI TWIN SYSTEMS per la POSA QUALITÀ è

- Disponibile presso le sedi dei consorziati e dei serramentisti di riferimento
- Liberamente scaricabile sul sito www.twinsystems.it nella sezione CATALOGHI

The TWIN SYSTEMS MANUAL and PRODUCT CATALOGUE for POSA QUALITÀ

- Is available from consortium members and reference window and door manufacturers
- Free download from the website www.twinsystems.it in the CATALOGUES section

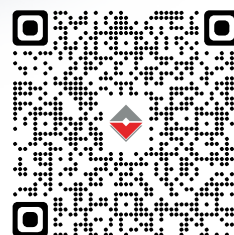



1 Anta Fissa EXT + 1 Anta mobile INT | Versione 90°
(1 Fixed EXT Sash + 1 Mobile INT Sash) 90° Version

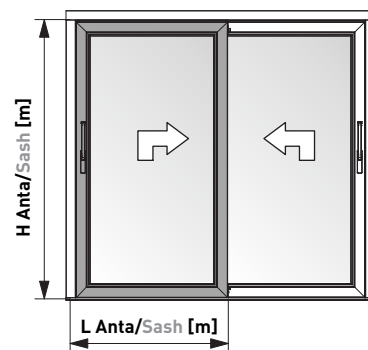
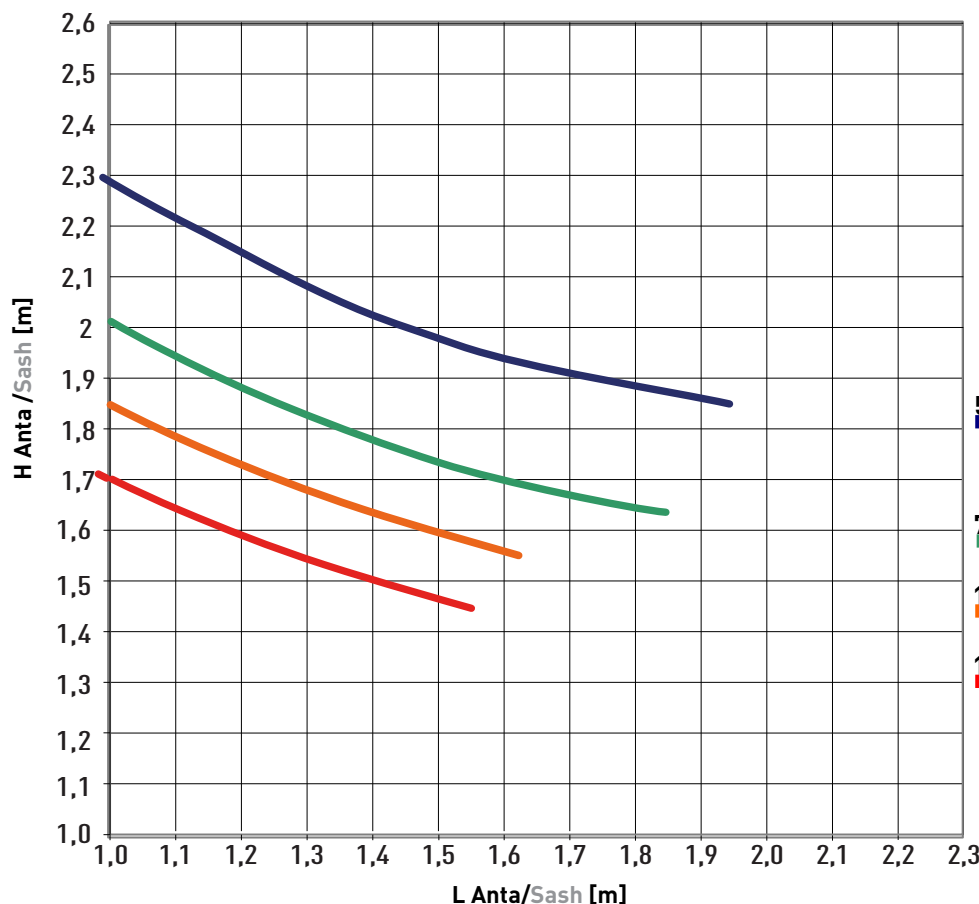

Centrale Ridotto
Reduced Middle Stud

500 Pa

750 Pa

1000 Pa

1250 Pa

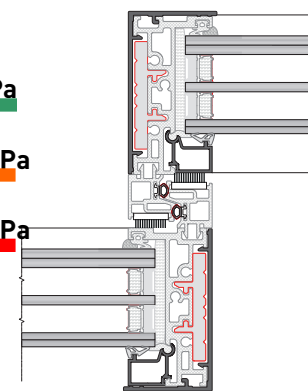

BX48 + HM16.306

**Infisso a 2 ante.
Deflessione del nodo centrale**

Il dimensionamento risultante dal grafico è solo indicativo. Il progettista o il serramentista, nel determinare le dimensioni massime dei serramenti, dovrà considerare e valutare, oltre le dimensioni ed il momento d'inerzia dei profilati, anche le caratteristiche applicative e meteorologiche quali l'altezza dal suolo, l'esposizione alla pioggia e la velocità dei venti nella zona.

Per questi dati consigliamo di consultare e seguire le "Raccomandazioni UNCSAAL" elaborate sulla base delle norme UNI, UNI-EN e UNI-CNR esistenti in merito. Verificare che la freccia del profilato sia compatibile con quella del vetro utilizzato.

Le curve rappresentano la larghezza massima dell'anta in funzione della sua altezza e della pressione del vento. Il serramento è considerato a 2 ante uguali. Le curve sono calcolate sulla base della deformazione elastica di 1/300 dell'altezza del serramento.

**Double sash windows.
Deflection of the central node**

In determining the maximum dimensions of the doors and windows, in addition to the dimensions and moment of inertia of the profiles, the designer or manufacturer must also consider and evaluate the application and meteorological conditions such as the height from the ground, exposure to rain and the speed of the winds in the area.

For these data, we recommend consulting and following the "UNCSAAL Recommendations" drawn up on the basis of the relative UNI, UNI-EN and UNI-CNR standards. Check that the arrow on the profile is compatible with the arrow on the glass used.

The curves represent the maximum width of the door as a function of its height and wind pressure. The frame is considered to have 2 doors. The curves are calculated on the basis of the elastic deformation of 1/300 of the height of the window.

NB: I dati dimensionali del grafico sono indicativi e da verificare in fase di progettazione esecutiva
NB: The dimensional data in the diagram are indicative and must be verified during the final design phase.



1 Anta Fissa EXT + 1 Anta mobile INT] + Rinforzi EXT/INT | **Versione 90°**
(1 Fixed EXT Sash + 1 Mobile INT Sash) + INT/EXT Reinforcement | 45° Version

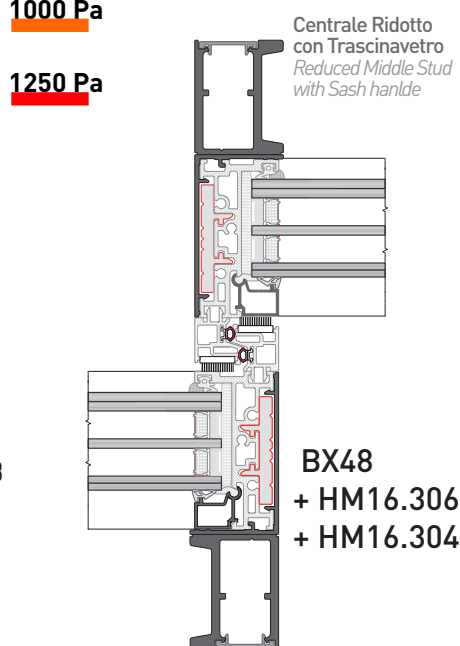
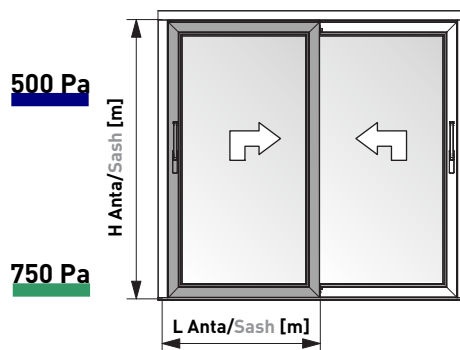
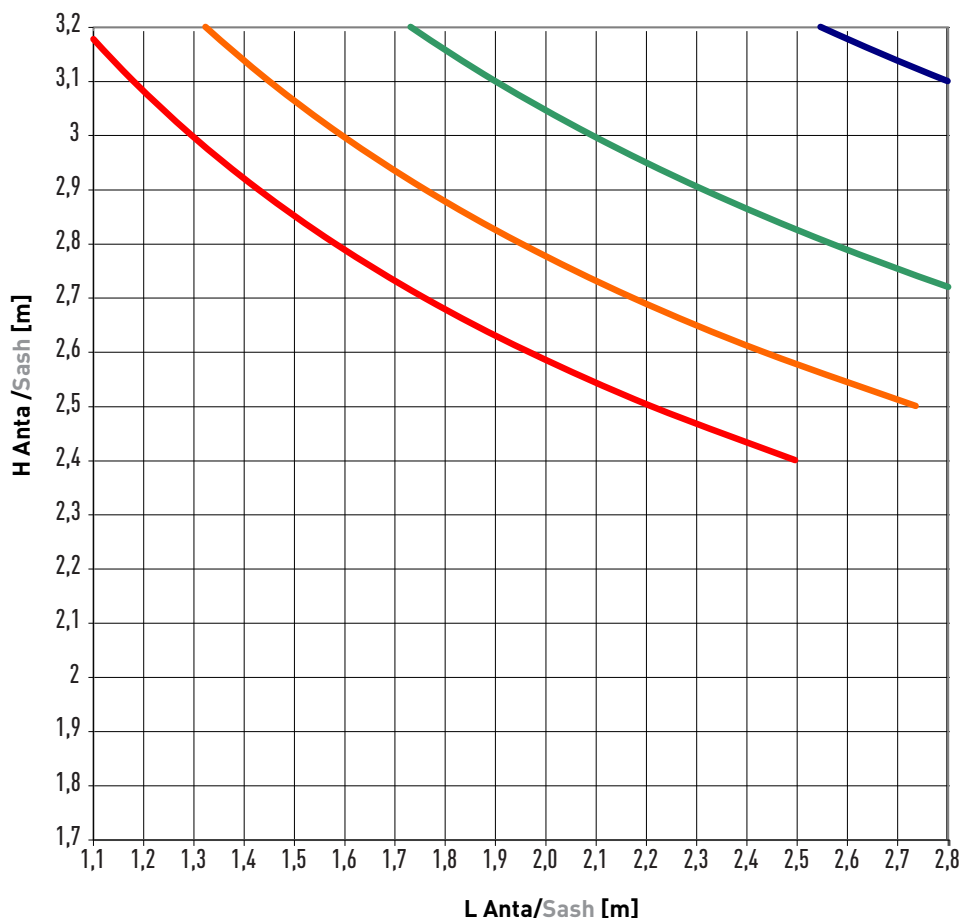

**Infisso a 2 ante.
Deflessione del nodo centrale**

Il dimensionamento risultante dal grafico è solo indicativo. Il progettista o il serramentista, nel determinare le dimensioni massime dei serramenti, dovrà considerare e valutare, oltre le dimensioni ed il momento d'inerzia dei profilati, anche le caratteristiche applicative e meteorologiche quali l'altezza dal suolo, l'esposizione alla pioggia e la velocità dei venti nella zona.

Per questi dati consigliamo di consultare e seguire le "Raccomandazioni UNCSAAL" elaborate sulla base delle norme UNI, UNI-EN e UNI-CNR esistenti in merito. Verificare che la freccia del profilato sia compatibile con quella del vetro utilizzato.

Le curve rappresentano la larghezza massima dell'anta in funzione della sua altezza e della pressione del vento. Il serramento è considerato a 2 ante uguali. Le curve sono calcolate sulla base della deformazione elastica di 1/300 dell'altezza del serramento.

**Double sash windows.
Deflection of the central node**

In determining the maximum dimensions of the doors and windows, in addition to the dimensions and moment of inertia of the profiles, the designer or manufacturer must also consider and evaluate the application and meteorological conditions such as the height from the ground, exposure to rain and the speed of the winds in the area.

For these data, we recommend consulting and following the "UNCSAAL Recommendations" drawn up on the basis of the relative UNI, UNI-EN and UNI-CNR standards. Check that the arrow on the profile is compatible with the arrow on the glass used.

The curves represent the maximum width of the door as a function of its height and wind pressure. The frame is considered to have 2 doors. The curves are calculated on the basis of the elastic deformation of 1/300 of the height of the window.

NB: I dati dimensionali del grafico sono indicativi e da verificare in fase di progettazione esecutiva
NB: The dimensional data in the diagram are indicative and must be verified during the final design phase.



1 Anta Fissa EXT + 1 Anta mobile INT + Rinforzo INT | **Versione 90°**
(1 Fixed EXT Sash + 1 Mobile INT Sash) + EXT Reinforcement | 45° Version

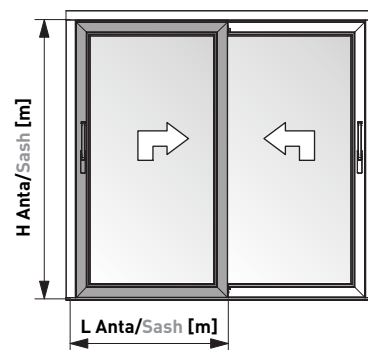
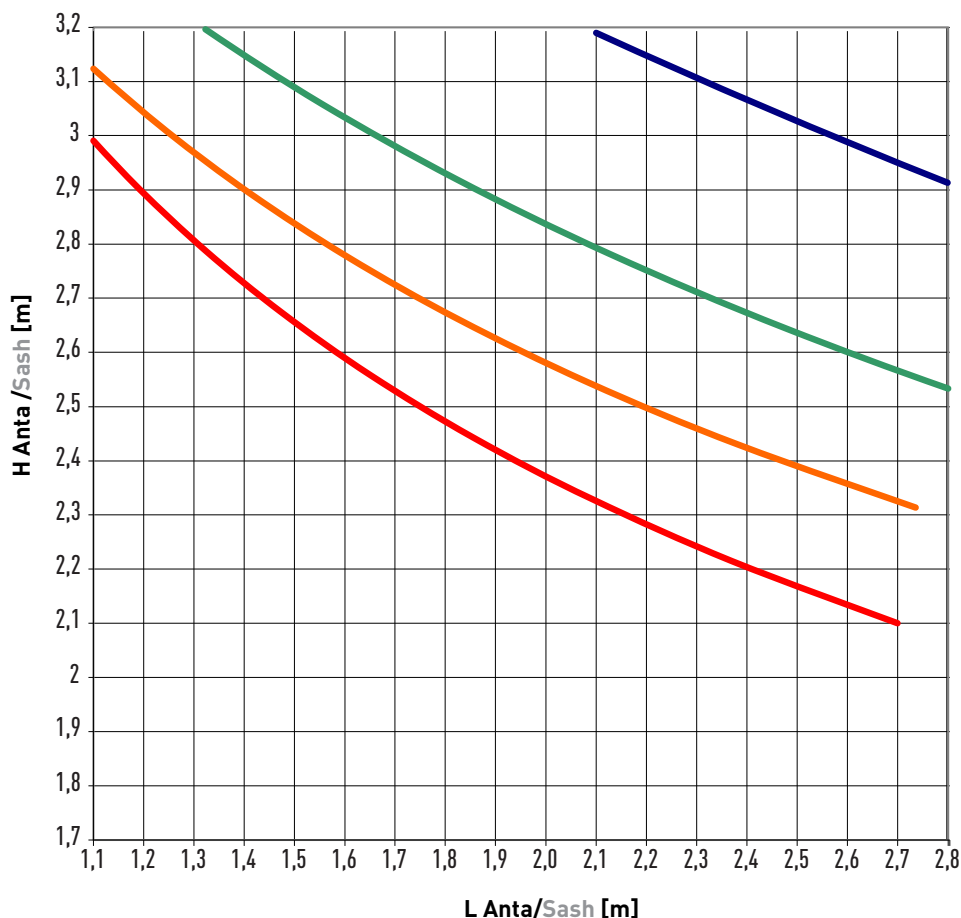

Centrale Ridotto con Trascinavetro INT
Reduced Middle Stud with INT Sash handle

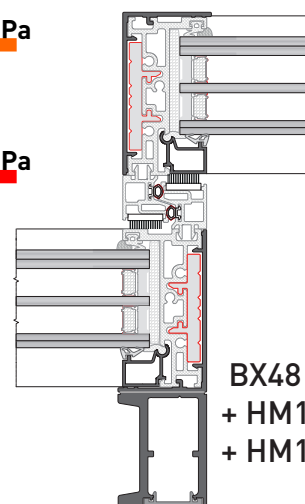

BX48
+ HM16.306
+ HM16.304

**Infisso a 2 ante.
Deflessione del nodo centrale**

Il dimensionamento risultante dal grafico è solo indicativo. Il progettista o il serramentista, nel determinare le dimensioni massime dei serramenti, dovrà considerare e valutare, oltre le dimensioni ed il momento d'inerzia dei profilati, anche le caratteristiche applicative e meteorologiche quali l'altezza dal suolo, l'esposizione alla pioggia e la velocità dei venti nella zona.

Per questi dati consigliamo di consultare e seguire le "Raccomandazioni UNCSAAL" elaborate sulla base delle norme UNI, UNI-EN e UNI-CNR esistenti in merito. Verificare che la freccia del profilato sia compatibile con quella del vetro utilizzato.

Le curve rappresentano la larghezza massima dell'anta in funzione della sua altezza e della pressione del vento. Il serramento è considerato a 2 ante uguali. Le curve sono calcolate sulla base della deformazione elastica di 1/300 dell'altezza del serramento.

**Double sash windows.
Deflection of the central node**

In determining the maximum dimensions of the doors and windows, in addition to the dimensions and moment of inertia of the profiles, the designer or manufacturer must also consider and evaluate the application and meteorological conditions such as the height from the ground, exposure to rain and the speed of the winds in the area.

For these data, we recommend consulting and following the "UNCSAAL Recommendations" drawn up on the basis of the relative UNI, UNI-EN and UNI-CNR standards. Check that the arrow on the profile is compatible with the arrow on the glass used.

The curves represent the maximum width of the door as a function of its height and wind pressure. The frame is considered to have 2 doors. The curves are calculated on the basis of the elastic deformation of 1/300 of the height of the window.

NB: I dati dimensionali del grafico sono indicativi e da verificare in fase di progettazione esecutiva
NB: The dimensional data in the diagram are indicative and must be verified during the final design phase.



1 Anta Fissa EXT + 1 Anta mobile INT | **Versione 45°**
(1 Fixed EXT Sash + 1 Mobile INT Sash) 45° Version

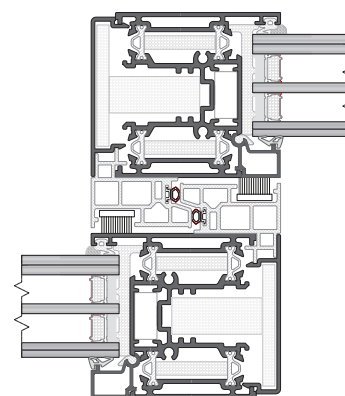
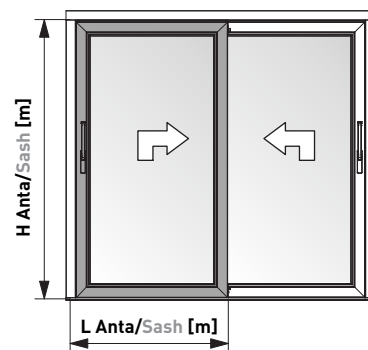
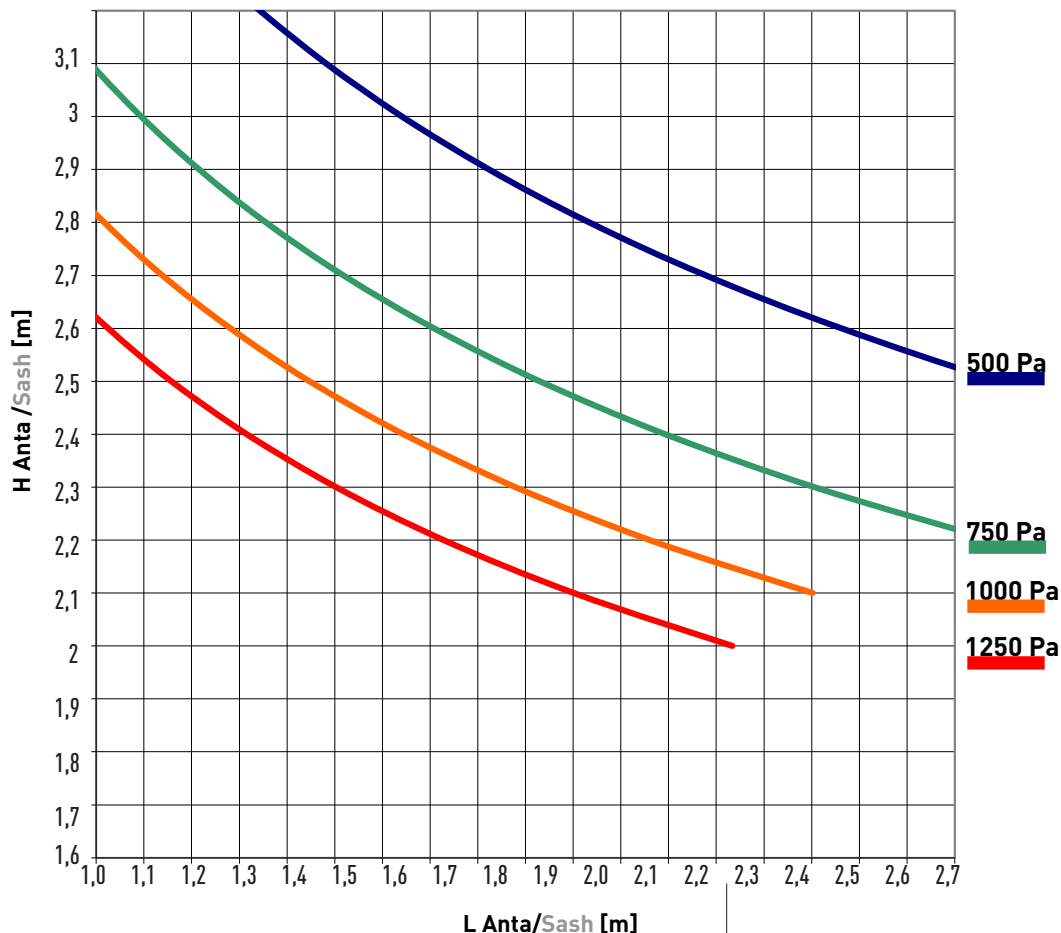

HM16.204

**Infisso a 2 ante.
Deflessione del nodo centrale**

Il dimensionamento risultante dal grafico è solo indicativo. Il progettista o il serramentista, nel determinare le dimensioni massime dei serramenti, dovrà considerare e valutare, oltre le dimensioni ed il momento d'inerzia dei profilati, anche le caratteristiche applicative e meteorologiche quali l'altezza dal suolo, l'esposizione alla pioggia e la velocità dei venti nella zona.

Per questi dati consigliamo di consultare e seguire le "Raccomandazioni UNCSAAL" elaborate sulla base delle norme UNI, UNI-EN e UNI-CNR esistenti in merito. Verificare che la freccia del profilato sia compatibile con quella del vetro utilizzato.

Le curve rappresentano la larghezza massima dell'anta in funzione della sua altezza e della pressione del vento. Il serramento è considerato a 2 ante uguali. Le curve sono calcolate sulla base della deformazione elastica di 1/300 dell'altezza del serramento.

**Double sash windows.
Deflection of the central node**

In determining the maximum dimensions of the doors and windows, in addition to the dimensions and moment of inertia of the profiles, the designer or manufacturer must also consider and evaluate the application and meteorological conditions such as the height from the ground, exposure to rain and the speed of the winds in the area.

For these data, we recommend consulting and following the "UNCSAAL Recommendations" drawn up on the basis of the relative UNI, UNI-EN and UNI-CNR standards. Check that the arrow on the profile is compatible with the arrow on the glass used.

The curves represent the maximum width of the door as a function of its height and wind pressure. The frame is considered to have 2 doors. The curves are calculated on the basis of the elastic deformation of 1/300 of the height of the window.

NB: I dati dimensionali del grafico sono indicativi e da verificare in fase di progettazione esecutiva
NB: The dimensional data in the diagram are indicative and must be verified during the final design phase.



1 Anta Fissa EXT + 1 Anta mobile INT) + Rinforzi EXT/INT | **Versione 45°**
(1 Fixed EXT Sash + 1 Mobile INT Sash) + INT/EXT Reinforcement | 45° Version

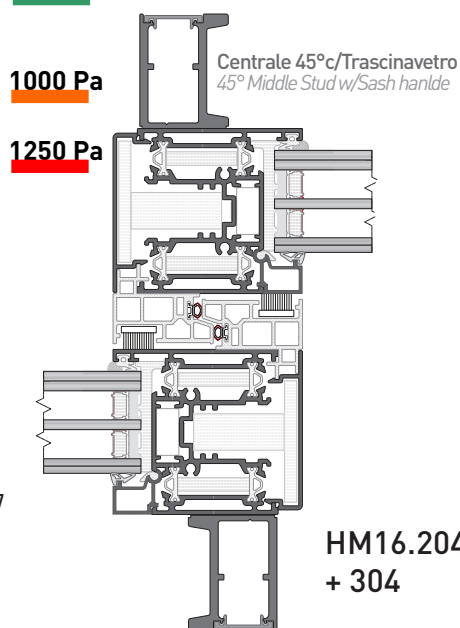
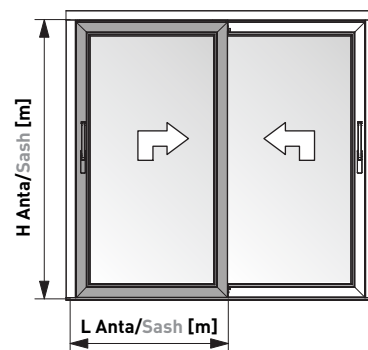
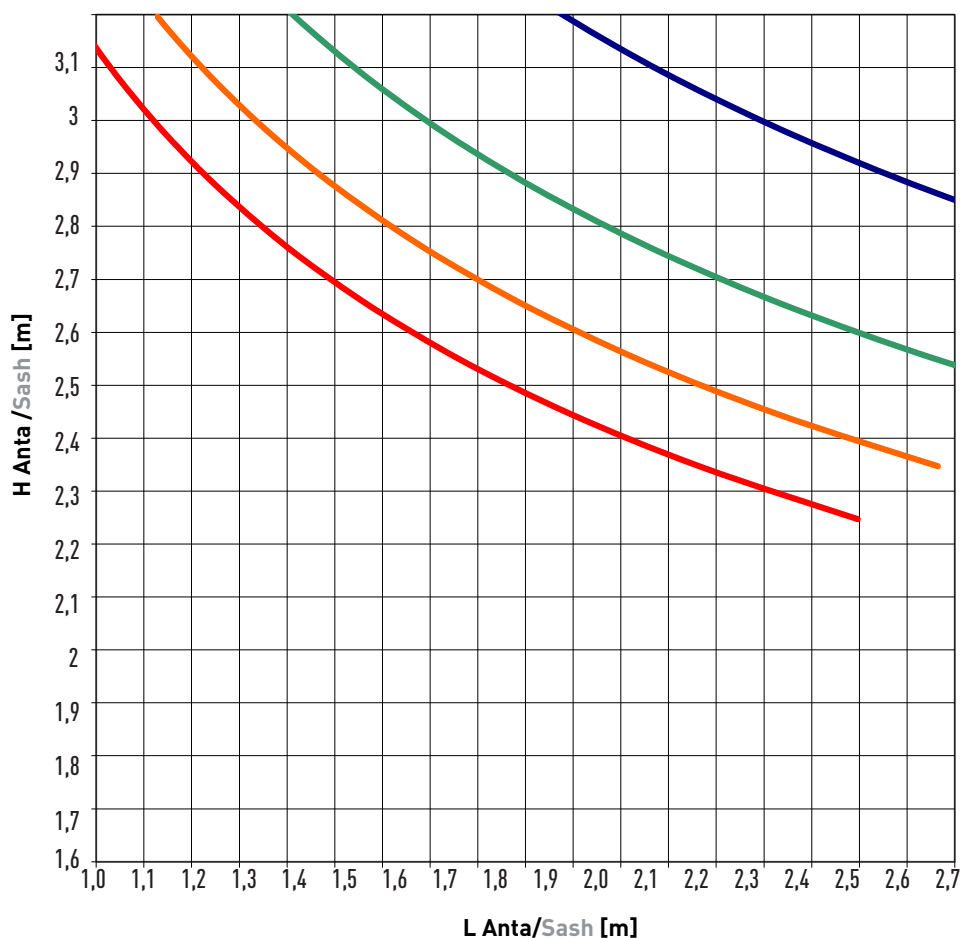

**Infisso a 2 ante.
Deflessione del nodo centrale**

Il dimensionamento risultante dal grafico è solo indicativo. Il progettista o il serramentista, nel determinare le dimensioni massime dei serramenti, dovrà considerare e valutare, oltre le dimensioni ed il momento d'inerzia dei profilati, anche le caratteristiche applicative e meteorologiche quali l'altezza dal suolo, l'esposizione alla pioggia e la velocità dei venti nella zona.

Per questi dati consigliamo di consultare e seguire le "Raccomandazioni UNCSAAL" elaborate sulla base delle norme UNI, UNI-EN e UNI-CNR esistenti in merito. Verificare che la freccia del profilato sia compatibile con quella del vetro utilizzato.

Le curve rappresentano la larghezza massima dell'anta in funzione della sua altezza e della pressione del vento. Il serramento è considerato a 2 ante uguali. Le curve sono calcolate sulla base della deformazione elastica di 1/300 dell'altezza del serramento.

**Double sash windows.
Deflection of the central node**

In determining the maximum dimensions of the doors and windows, in addition to the dimensions and moment of inertia of the profiles, the designer or manufacturer must also consider and evaluate the application and meteorological conditions such as the height from the ground, exposure to rain and the speed of the winds in the area.

For these data, we recommend consulting and following the "UNCSAAL Recommendations" drawn up on the basis of the relative UNI, UNI-EN and UNI-CNR standards. Check that the arrow on the profile is compatible with the arrow on the glass used.

The curves represent the maximum width of the door as a function of its height and wind pressure. The frame is considered to have 2 doors. The curves are calculated on the basis of the elastic deformation of 1/300 of the height of the window.

**NB: I dati dimensionali del grafico sono indicativi e da verificare in fase di progettazione esecutiva
NB: The dimensional data in the diagram are indicative and must be verified during the final design phase.**



EFFETTO BI-METAL

Il fenomeno fisico denominato "effetto bi-metal" si manifesta con una deformazione ad arco dei profili a taglio termico, quando le due superfici (interna ed esterna) del serramento sono sottoposte ad una sensibile differenza di temperatura.

Ricordando che la norma EN14024 sulle prestazioni meccaniche dei profili metallici richiede un efficace ammorsamento dei componenti di alluminio con le barrette isolanti per conferire un'adeguata resistenza a taglio del profilo, questo produce l'effetto di impedire qualsiasi dilatazione differenziale tra i due semiprofilo quando le superfici interna ed esterna si trovino a temperature diverse tra loro.

Ciò determina una flessione ad arco verso il lato più caldo, di entità proporzionale alla differenza termica e più rilevante per i profili maggiormente isolati.

Dilatazione in caso di ELEMENTI LIBERI

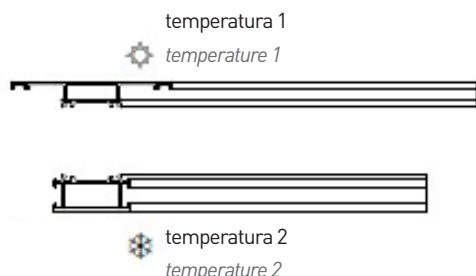

I rischi maggiori possono insorgere in caso di serramenti di colore scuro esposti alla radiazione solare diretta, in qualsiasi stagione, o altre situazioni in cui si generi un gradiente termico elevato tra superficie interna ed esterna del profilo.

In genere questo fenomeno non determina particolari conseguenze negative sulle finestre tradizionali a battente, mentre può causare il mancato allineamento delle chiusure con i relativi incontri su profili per porte o su sistemi scorrevoli con conseguenti anomalie di funzionamento in fase di apertura e chiusura.

Nel caso di serramenti scorrevoli, il fenomeno potrebbe riguardare anche i traversi orizzontali dell'anta che, spanciando verso le guide del telaio, possono compromettere il regolare scorrimento.

Le conseguenze possono coinvolgere anche aspetti legati alla sicurezza, come la difficoltà di apertura in situazioni di emergenza, se riferite a porte sulle vie di esodo.

SOLUZIONI

Per cercare di ridurre il più possibile gli inconvenienti sopra descritti, Twin Systems propone diverse soluzioni in funzione della specifica serie, adottando di volta in volta i giusti compromessi tra resistenza meccanica e riduzione dell'effetto bi-metal. In ogni caso, essendo il fenomeno **non eliminabile totalmente**, in presenza di elevate differenze di temperatura fra esterno ed interno degli infissi o irraggiamenti solari diretti, in particolare con superfici scure ed elementi di dimensioni elevate, è sempre suggerita un'analisi più accurata delle condizioni, fino a coinvolgere il progettista dell'edificio nella ricerca delle soluzioni, anche architettoniche, più opportune. Si raccomanda di trattare questo tema con la stessa attenzione in genere riservata ad altri importanti aspetti tecnici quali l'isolamento termico ed acustico, il fenomeno della condensa, la permeabilità all'aria, la tenuta all'acqua, la resistenza meccanica ecc.

Come base per la serie HM160, viene proposta la soluzione con barrette isolanti standard regolarmente ammorsate ai profili di alluminio per massimizzare le caratteristiche statiche e meccaniche, generalmente prioritarie specialmente per i montanti intermedi di un serramento scorrevole di grandi dimensioni.

Per qualsiasi chiarimento è possibile consultare il nostro ufficio tecnico.

BI-METAL EFFECT

The physical phenomenon known as the "bi-metal effect" occurs with an arched deformation of the thermal break profiles, when the two surfaces (internal and external) of the window are subjected to a significant difference in temperature.

Recalling that the EN14024 standard on the mechanical performance of metal profiles requires an effective clamping of the aluminum components with the insulating bars to give the profile adequate shear strength, this produces the effect of preventing any differential expansion between the two semi-profiles when the internal and external surfaces are at different temperatures.

This determines an arc bending towards the hotter side, proportional to the thermal difference and more relevant for the more insulated profiles

Dilatation in the case of BINDING ELEMENTS

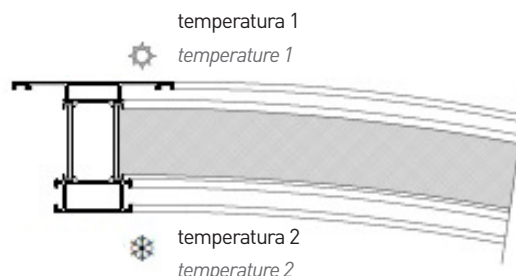

The greatest risks can arise in the case of dark colored windows exposed to direct solar radiation, in any season, or other situations in which a high thermal gradient is generated between the internal and external surface of the profile.

In general, this phenomenon does not cause particular negative consequences on traditional casement windows, while it can cause the closures to not align with the relative strikers on door profiles or sliding systems with consequent malfunctions during the opening and closing phases.

In the case of sliding windows, the phenomenon could also concern the horizontal crosspieces of the sash which, bulging towards the guides of the frame, can compromise regular sliding.

The consequences can also involve aspects related to safety, such as the difficulty of opening in emergency situations, if referring to doors on escape routes.

SOLUTIONS

To try to reduce the drawbacks described above as much as possible, Twin Systems offers various solutions according to the specific series, each time adopting the right compromises between mechanical strength and reduction of the bi-metal effect. In any case, since the phenomenon **cannot be totally eliminated**, in the presence of high temperature differences between the outside and inside of the fixtures or direct sunlight, especially with dark surfaces and large elements, a more accurate analysis of the conditions is always recommended, up to involving the building designer in the search for the most appropriate solutions, including architectural ones. It is recommended to treat this issue with the same attention generally reserved for other important technical aspects such as thermal and acoustic insulation, the phenomenon of condensation, air permeability, water tightness, mechanical resistance, etc.

As a basis for the HM160 series, the solution with standard insulating bars regularly clamped to the aluminum profiles is proposed to maximize the static and mechanical characteristics, generally a priority especially for the intermediate uprights of a large sliding window.

For any clarification you can consult our technical office.

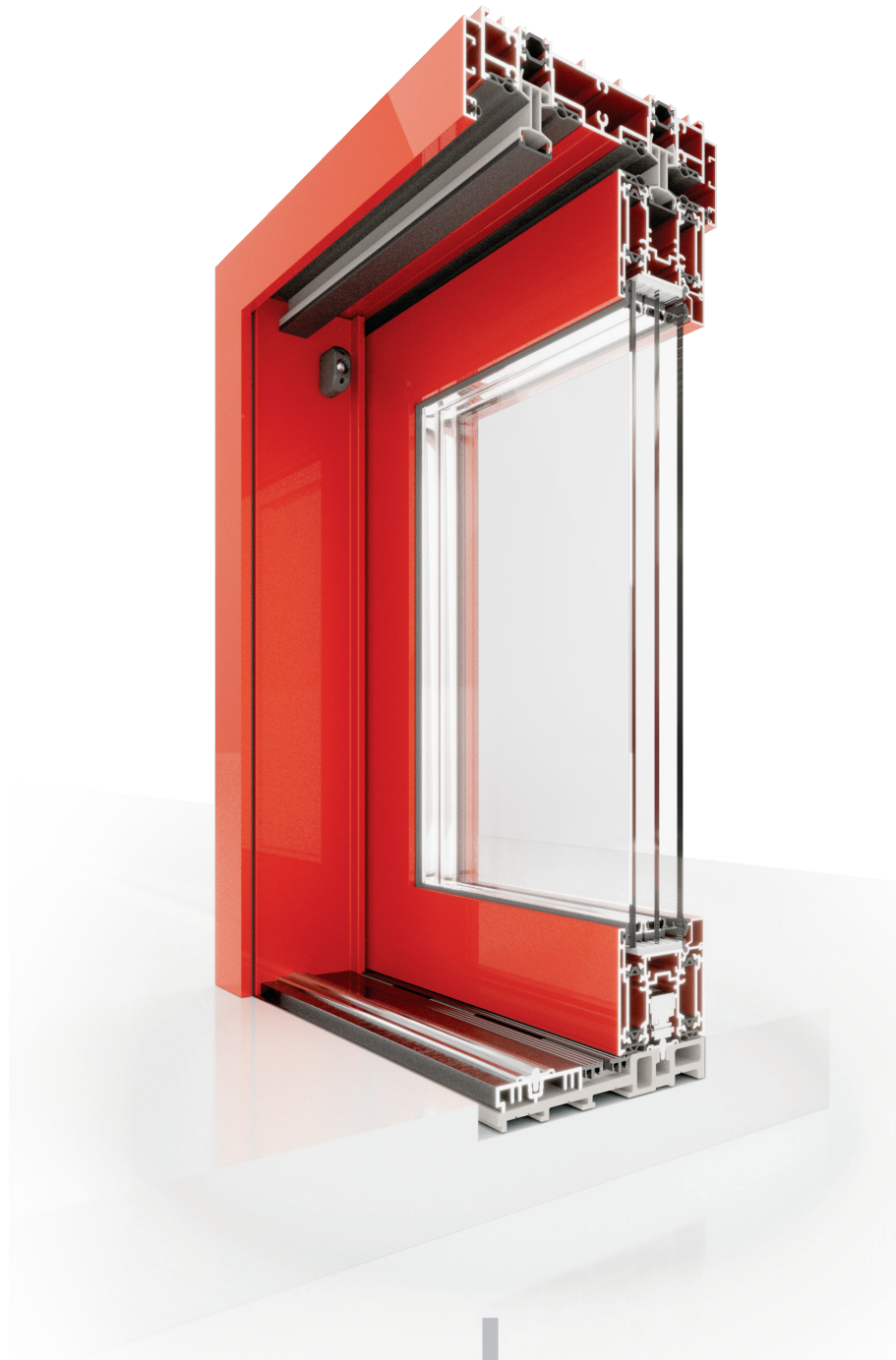

Profili
Profiles

Gruppo B

Elenco Profili
Profili Scala 1:1

Profiles List
Profiles Scale 1:1

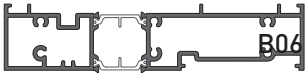

HX16.105			Tavola Table B04
Telaio montante laterale			
<i>Lateral Mullion Frame Profile</i>			
Peso Weight kg/ml 2.948			
J_x 270.3 cm ⁴ W_x 33.04	J_y 13.52 cm ⁴ W_y 7.26 cm ³		

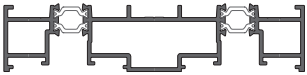
HX16.106			Tavola Table B05
Telaio Traverso Superiore			
<i>Upper Transom Frame Profile</i>			
Peso Weight kg/ml 2.983			
J_x 0 cm ⁴ W_x 0	J_y 0 cm ⁴ W_y 0 cm ³		

HX16.107			Tavola Table B05
Telaio soglia inferiore			
<i>Lower Threshold Frame</i>			
Peso Weight kg/ml 1.86			
J_x 0 cm ⁴ W_x 0	J_y 0 cm ⁴ W_y 0 cm ³		

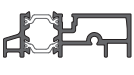
HM16.108			Tavola Table B06
Telaio soglia inferiore Monoanta			
<i>Single Sash Lower Threshold Frame</i>			
Peso Weight kg/ml 1.247			
J_x 0 cm ⁴ W_x 0	J_y 0 cm ⁴ W_y 0 cm ³		

HX16.110			Tavola Table B06
Telaio soglia a filo pavimento			
<i>Floorlevel Threshold frame</i>			
Peso Weight kg/ml 2.603			
J_x 0 cm ⁴ W_x 0	J_y 0 cm ⁴ W_y 0 cm ³		

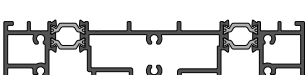
HM16.111			Tavola Table B05
Telaio Montante + Traverso Sup. per F+M			
<i>Frame Upright + Upper Transom for F + M</i>			
Peso Weight kg/ml 3.331			
J_x 292.77cm ⁴ W_x 36.77	J_y 12.8 cm ⁴ W_y 6.78 cm ³		

HM16.112			Tavola Table B05
Telaio Traverso Superiore Monoanta			
<i>Single Sash Upper Transom Frame</i>			
Peso Weight kg/ml 1.704			
J_x 0 cm ⁴ W_x 0 cm ³	J_y 0 cm ⁴ W_y 0 cm ³		

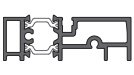
HM16.113			Tavola Table B06
Telaio soglia inferiore Monoanta [Variante]			
<i>Single Sash Upper Transom Frame</i>			
Peso Weight kg/ml 1.328			
J_x 0 cm ⁴ W_x 0 cm ³	J_y 0 cm ⁴ W_y 0 cm ³		

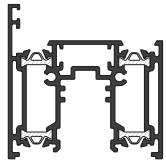
HM16.204			Tavola Table B07
Anta con fermavetro			
<i>Sash with glazing bead</i>			
Peso Weight kg/ml 2.477			
J_x 47.75 cm ⁴ W_x 13.52	J_y 22.55 cm ⁴ W_y 5.98 cm ³		

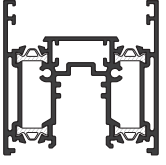
HM16.205			Tavola Table B07
Anta vetro ad infilare			
<i>Insertion glass sash</i>			
Peso Weight kg/ml 2.57			
J_x 51.52 cm ⁴ W_x 15.15	J_y 26.01 cm ⁴ W_y 7.13 cm ³		

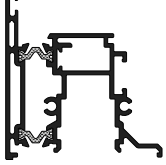
HM18.205			Tavola Table B09
Anta per soluzione legno			
<i>Sash for wood solution</i>			
Peso Weight kg/ml 2.24			
J_x 21.83 cm ⁴ W_x 5.22	J_y 18.38 cm ⁴ W_y 4.79 cm ³		

HX16.303			Tavola Table B08
Profilo centrale 4 anta			
<i>Central orofile .f sash</i>			
Peso Weight kg/ml 0.146			
J_x 0 cm ⁴ W_x 0	J_y 0 cm ⁴ W_y 0 cm ³		

HM16.304			Tavola Table B07
Profilo di trascinamento			
<i>Drag and drop profile</i>			
Peso Weight kg/ml 1.355			
J_x 13.75 cm ⁴ W_x 5.04	J_y 8.58 cm ⁴ W_y 4.31 cm ³		

HM16.306			Tavola Table B07
Cover centrale anta nodo ridotto			
<i>Reduced node central sash cover</i>			
Peso Weight kg/ml 0.567			
J_x 11.28 cm ⁴ W_x 2.42	J_y 2.31 cm ⁴ W_y 0.07 cm ³		

HM16.307			Tavola Table B07
Cover centrale anta			
<i>Central sash cover</i>			
Peso Weight kg/ml 0.39			
J_x 0 cm ⁴ W_x 0	J_y 0 cm ⁴ W_y 0 cm ³		

HM16.308			Tavola Table B07
Profilo interno di rinforzo centrale			
<i>Central internal reinforcement profile</i>			
Peso Weight kg/ml 0.788			
J_x 4.82 cm ⁴ W_x 2.08	J_y 2.2 cm ⁴ W_y 0.02 cm ³		





XX16.102			Tavola Table B08
Doga per Soglia FILOPAVIMENTO			
<i>Bed for FLOORLEVER Threshold</i>			
Peso Weight kg/ml 0.14			
J _x 0 cm ⁴	W _x 0		
J _y 0 cm ⁴	W _y 0 cm ³		

HM18.506			Tavola Table B07
Fermavetro anta per soluzione legno			
<i>Sash glazing bead for wood solution</i>			
Peso Weight kg/ml 0.212			
J _x 0 cm ⁴	W _x 0		
J _y 0 cm ⁴	W _y 0 cm ³		

HX16.149			Tavola Table B08
Binario Singolo Ribassato			
<i>Single Lowered Rail</i>			
Peso Weight kg/ml 0.267			
J _x 0 cm ⁴	W _x 0		
J _y 0 cm ⁴	W _y 0 cm ³		

HM18.507			Tavola Table B09
Fermavetro per soluzione legno			
<i>Glazing bead for wood solution</i>			
Peso Weight kg/ml 0.305			
J _x 0 cm ⁴	W _x 0		
J _y 0 cm ⁴	W _y 0 cm ³		

HX16.169			Tavola Table B08
Binario Alluminio			
<i>Aluminum Rail</i>			
Peso Weight kg/ml 0.231			
J _x 0 cm ⁴	W _x 0		
J _y 0 cm ⁴	W _y 0 cm ³		

HM16.507			Tavola Table B07
Supporto fermavetro inferiore			
<i>Lower glass bead support</i>			
Peso Weight kg/ml 0.414			
J _x 0 cm ⁴	W _x 0		
J _y 0 cm ⁴	W _y 0 cm ³		

HX16.171			Tavola Table B08
Guida esterna per soglia			
<i>External threshold guide</i>			
Peso Weight kg/ml 0.688			
J _x 0 cm ⁴	W _x 0		
J _y 0 cm ⁴	W _y 0 cm ³		

HM16.508			Tavola Table B06
Cover profilo montante			
<i>Cover upright profile</i>			
Peso Weight kg/ml 0.577			
J _x 0 cm ⁴	W _x 0		
J _y 0 cm ⁴	W _y 0 cm ³		

HX16.503			Tavola Table B06
Cover Profilo Trasverso			
<i>Transom Profile Cover</i>			
Peso Weight kg/ml 0.593			
J _x 0 cm ⁴	W _x 0		
J _y 0 cm ⁴	W _y 0 cm ³		

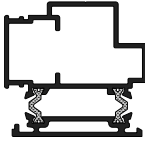
HM16.509			Tavola Table B08
Profilo interno soluzione ad angolo			
<i>Internal profile corner solution</i>			
Peso Weight kg/ml 1.702			
J _x 17.99 cm ⁴	W _x 5.77		
J _y 17.14 cm ⁴	W _y 5.88 cm ³		

HX16.504			Tavola Table B06
Cover Profilo Trasverso			
<i>Transom Profile Cover</i>			
Peso Weight kg/ml 0.344			
J _x 0 cm ⁴	W _x 0		
J _y 0 cm ⁴	W _y 0 cm ³		

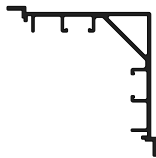
HM16.510			Tavola Table B08
Profilo Esterno Soluzione Angolo			
<i>External PProfile for Corner Solution</i>			
Peso Weight kg/ml 1.220			
J _x 28.01 cm ⁴	W _x 5.21		
J _y 25.33 cm ⁴	W _y 4.55 cm ³		

HM16.505			Tavola Table B07
Battuta vetro per vetrazione fissa			
<i>Glass beating for fixed glazing</i>			
Peso Weight kg/ml 0.215			
J _x 0 cm ⁴	W _x 0		
J _y 0 cm ⁴	W _y 0 cm ³		

HM16.511			Tavola Table B08
Cover incontro 4 anta			
<i>Cover joint 4 sash</i>			
Peso Weight kg/ml 0.221			
J _x 0 cm ⁴	W _x 0		
J _y 0 cm ⁴	W _y 0 cm ³		

HM16.506			Tavola Table B07
Battuta vetro per vetrazione fissa inferiore			
<i>Glass beading for lower fixed glazing</i>			
Peso Weight kg/ml 0.497			
J _x 0 cm ⁴	W _x 0		
J _y 0 cm ⁴	W _y 0 cm ³		

HM16.512			Tavola Table B06
Cover Profilo Trasverso			
<i>Transom Profile Cover</i>			
Peso Weight kg/ml 1.247			
J _x 0 cm ⁴	W _x 0		
J _y 0 cm ⁴	W _y 0 cm ³		





XX70.704			Tavola Table B07
Cover Coprivite			
<i>Screw Certer</i>			
Peso Weight kg/ml 0.135			
J_x 0 cm ⁴ W_x 0	J_y 0 cm ⁴ W_y 0 cm ³		

MX603.501			Tavola Table B08
Fermavetro da mm. 13.6			
<i>Glazing Bead 13.6 mm.</i>			
Peso Weight kg/ml 0.216			
J_x 0 cm ⁴ W_x 0	J_y 0 cm ⁴ W_y 0 cm ³		

XX75.645			Tavola Table B08
Profilo per cartongesso			
<i>Drywall profile</i>			
Peso Weight kg/ml 0.224			
J_x 0 cm ⁴ W_x 0	J_y 0 cm ⁴ W_y 0 cm ³		

MX603.502			Tavola Table B08
Fermavetro da mm. 18.6			
<i>Glazing Bead 18.6 mm.</i>			
Peso Weight kg/ml 0.244			
J_x 0 cm ⁴ W_x 0	J_y 0 cm ⁴ W_y 0 cm ³		

DW86.101			Tavola Table B09
Adattatore fissaggio legno			
<i>Wood fixing adapter</i>			
Peso Weight kg/ml 0.258			
J_x 0 cm ⁴ W_x 0	J_y 0 cm ⁴ W_y 0 cm ³		

MX603.503			Tavola Table B08
Fermavetro da mm. 23.6			
<i>Glazing Bead 23.6 mm.</i>			
Peso Weight kg/ml 0.259			
J_x 0 cm ⁴ W_x 0	J_y 0 cm ⁴ W_y 0 cm ³		

HW18.304			Tavola Table B08
Adattatore fissaggio legno ANTA			
<i>Wood fixing adapter for SASH</i>			
Peso Weight kg/ml 0.224			
J_x 0 cm ⁴ W_x 0	J_y 0 cm ⁴ W_y 0 cm ³		

MX603.504			Tavola Table B08
Fermavetro da mm. 22.6			
<i>Glazing Bead 22.6 mm.</i>			
Peso Weight kg/ml 0.256			
J_x 0 cm ⁴ W_x 0 cm ³	J_y 0 cm ⁴ W_y 0 cm ³		

MX603.505			Tavola Table B08
Fermavetro da mm. 27.6			
<i>Glazing Bead 27.6 mm.</i>			
Peso Weight kg/ml 0.276			
J_x 0 cm ⁴ W_x 0 cm ³	J_y 0 cm ⁴ W_y 0 cm ³		

MX603.506			Tavola Table B08
Fermavetro da mm. 32.6			
<i>Glazing Bead 32.6 mm.</i>			
Peso Weight kg/ml 0.297			
J_x 0 cm ⁴ W_x 0	J_y 0 cm ⁴ W_y 0 cm ³		













MX603.509			Tavola Table B09
Adattatore fissaggio legno			
<i>Wood fixing adapter</i>			
Peso Weight kg/ml 0.21			
J_x 0 cm ⁴ W_x 0	J_y 0 cm ⁴ W_y 0 cm ³		

RC029			Tavola Table B06
Coprifilo			
<i>Casing Profile</i>			
Peso Weight kg/ml 0.222			
J_x 0 cm ⁴ W_x 0	J_y 0 cm ⁴ W_y 0 cm ³		

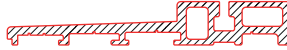

Poliamide
Polyamide

Legni
Woods

<p>BX48</p> <p>Profilo in poliammide di rinforzo centrale <i>Central reinforcing polyamide profile</i></p>		<p>Tavola Table B09</p>	<p>HW-D</p> <p>Sagoma legno per anta <i>Wood shape for sash</i></p>	 <p>Tavola Table</p>	
<p>BX49</p> <p>Profilo in poliammide guida superiore <i>Upper guide polyamide profile</i></p>		<p>Tavola Table B09</p>	<p>HW-E</p> <p>Sagoma legno per fermavetro anta <i>Wood shape for sash glazing bead</i></p>		<p>Tavola Table B09</p>
<p>BX50</p> <p>Profilo in poliammide labirinto ridotto <i>Reduced polyamide labyrinth profile</i></p>		<p>Tavola Table B09</p>	<p>HW-F</p> <p>Sagoma legno per fermavetro superiore <i>Wood shape for upper glass bead</i></p>		<p>Tavola Table B09</p>
<p>BX51</p> <p>Profilo in poliammide labirinto <i>Polyamide labyrinth profile</i></p>		<p>Tavola Table B09</p>	<p>HW-G</p> <p>Sagoma legno per nodo centrale <i>Wood profile for central node</i></p>		<p>Tavola Table B09</p>
<p>BX52</p> <p>Soglia inferiore materiale isolante <i>Lower threshold insulation material</i></p>	<p>Barre/Bars = 6.5 mts Conf = 4 pz. / Pack. = 4 pcs.</p> 	<p>Tavola Table B05</p>	<p>HW-H</p> <p>Sagoma legno per fermavetro inferiore <i>Wood shape for lower glass bead</i></p>		<p>Tavola Table B09</p>
<p>DW-A</p> <p>Sagoma legno per telaio <i>Wood shape for frame</i></p>		<p>Tavola Table B09</p>			
<p>HW-C</p> <p>Sagoma legno per profilo montante <i>Wood profile for mullion</i></p>		<p>Tavola Table B09</p>			

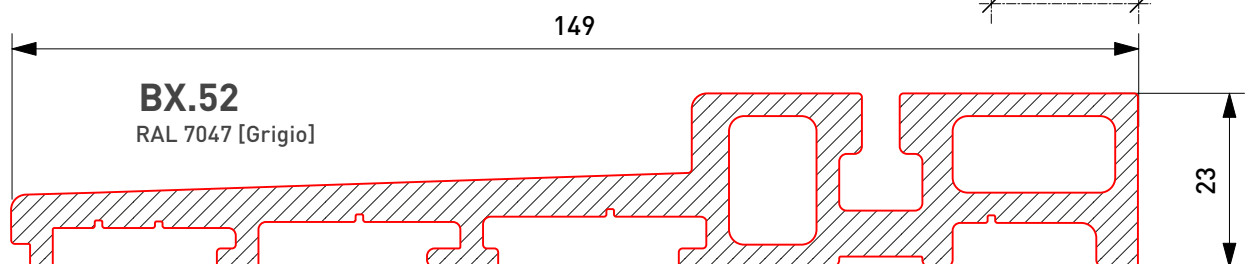
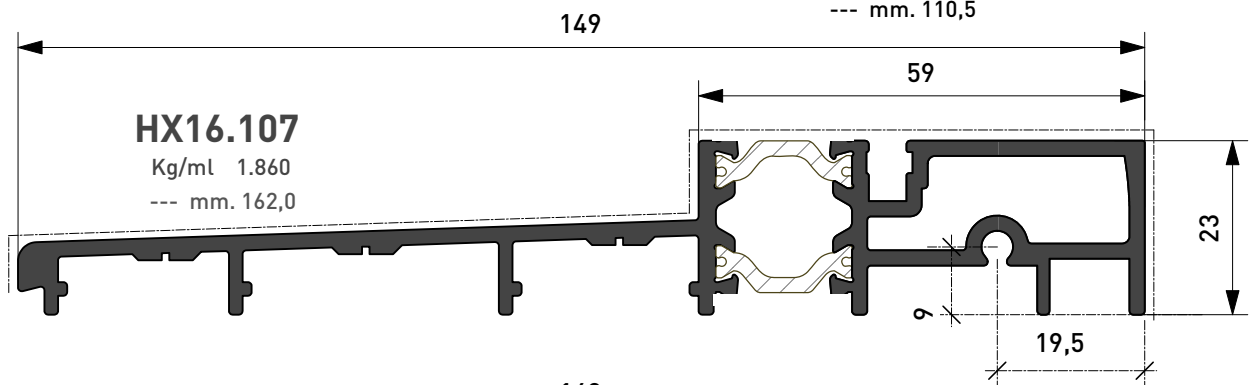
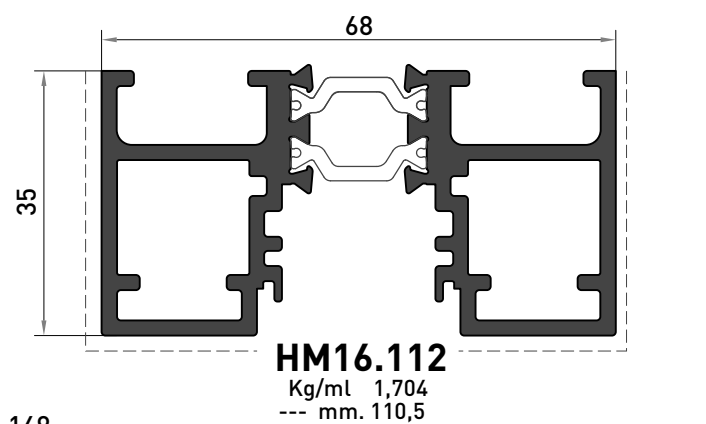
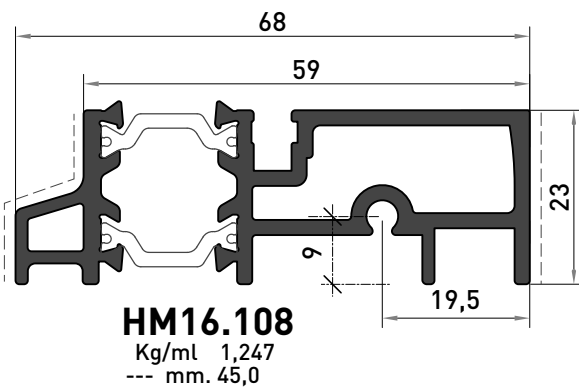
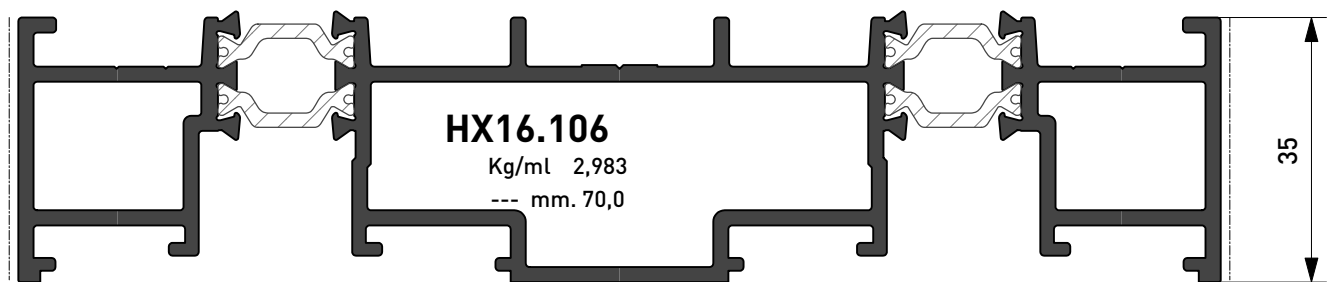
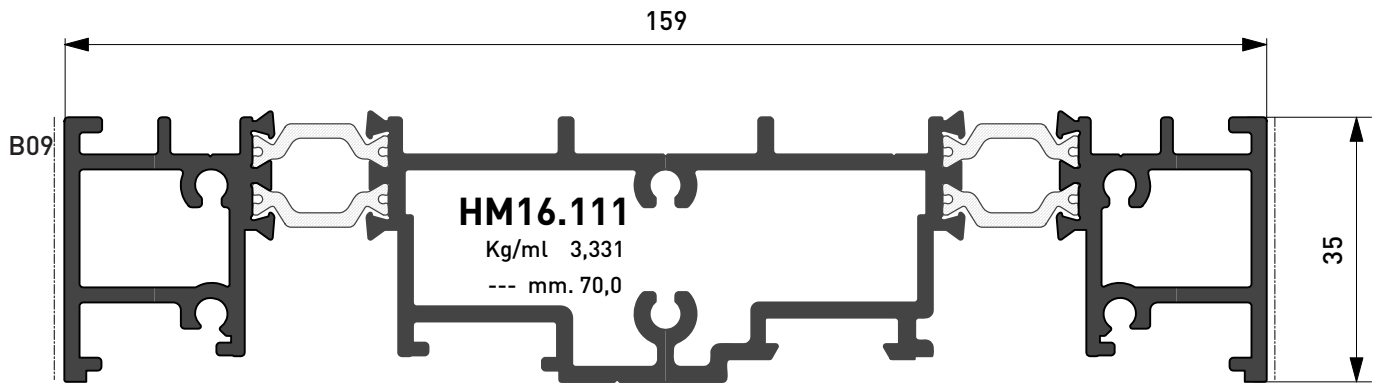

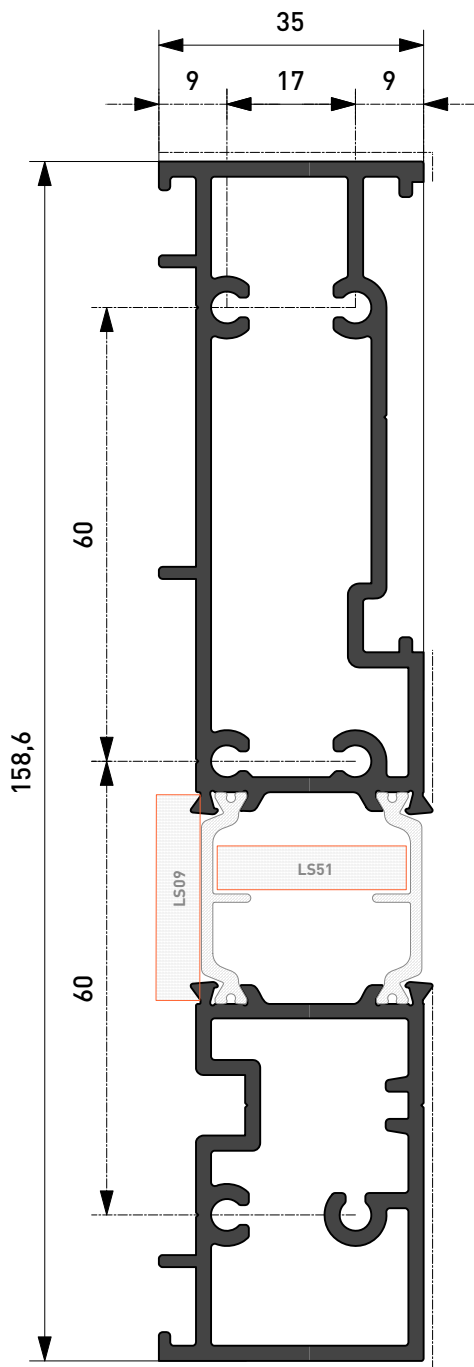

HX16.105
Kg/ml 2.948
--- mm. 162,0

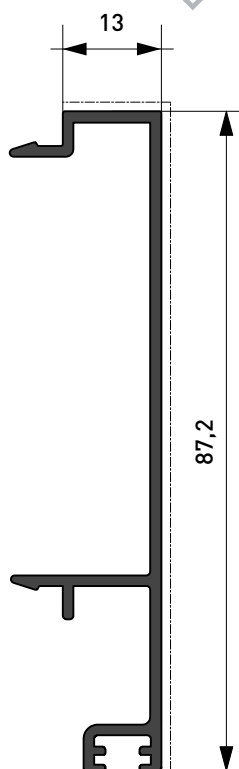

HX16.503
Kg/ml 0.593
--- mm. 100,0

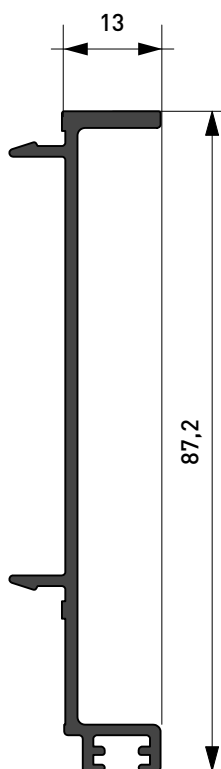

HM16.508
Kg/ml 0.577
--- mm. 100,0

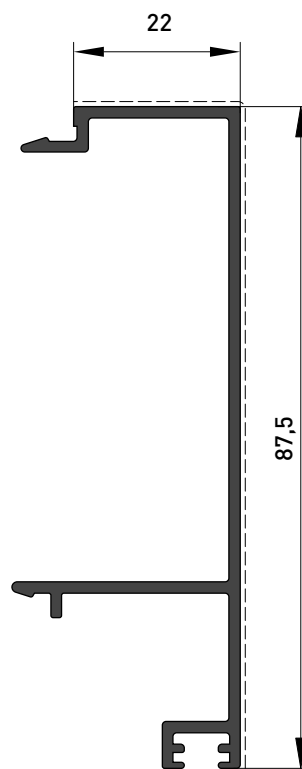

HM16.512
Kg/ml 0.682
--- mm. 110,5

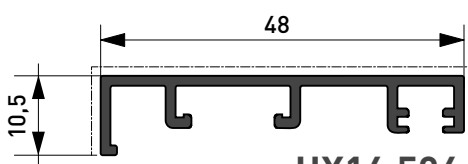

HX16.504
Kg/ml 0,344
--- mm. 66,0

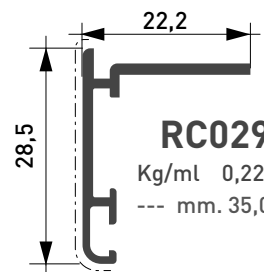

RC029
Kg/ml 0,222
--- mm. 35,0

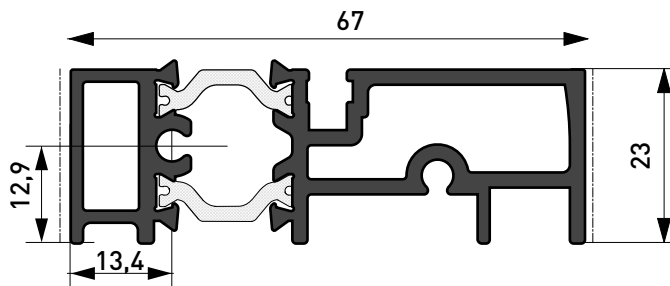

HM16.113
Kg/ml 1,328
--- mm. 46,0

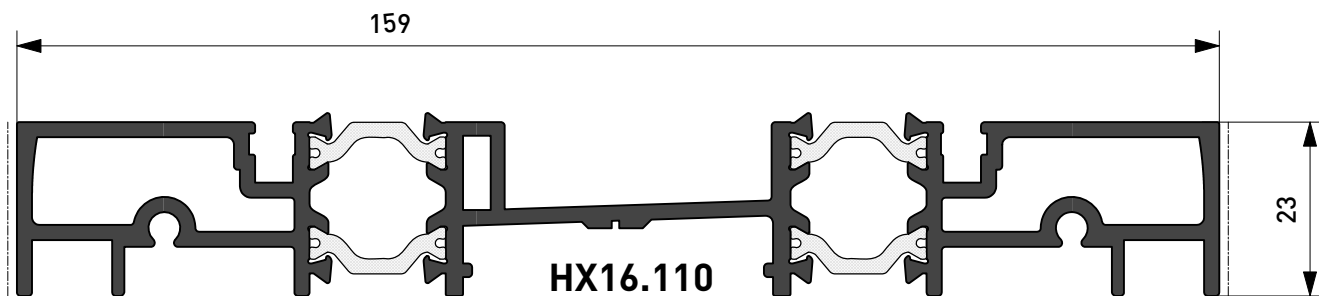

HX16.110
Kg/ml 2,603
--- mm. 46,0

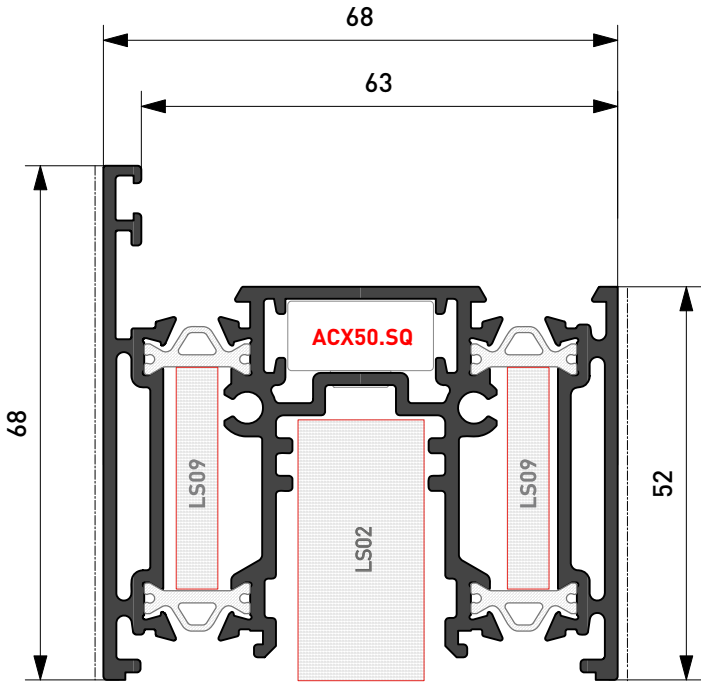

HM16.204

Kg/ml 2.477
--- mm. 162,0

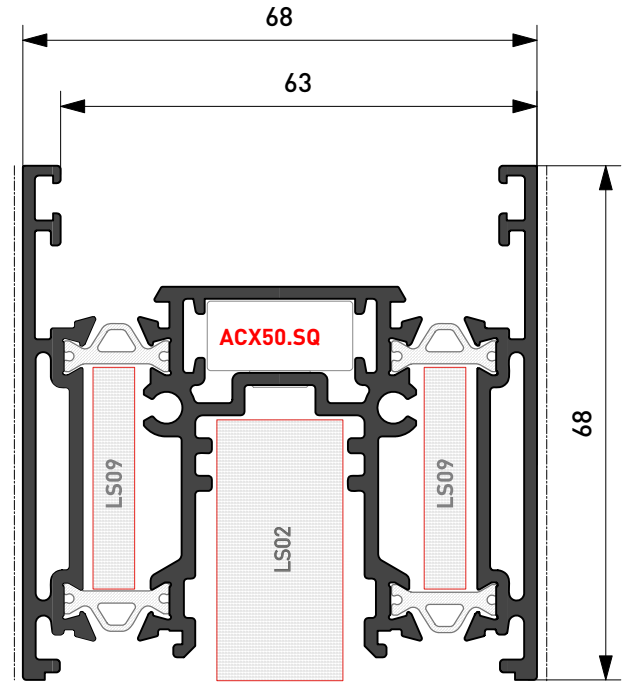

HM16.205

Kg/ml 2.570
--- mm. 162,0

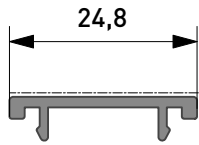

XX70.704

Kg/ml 0.135
--- mm. 25,0

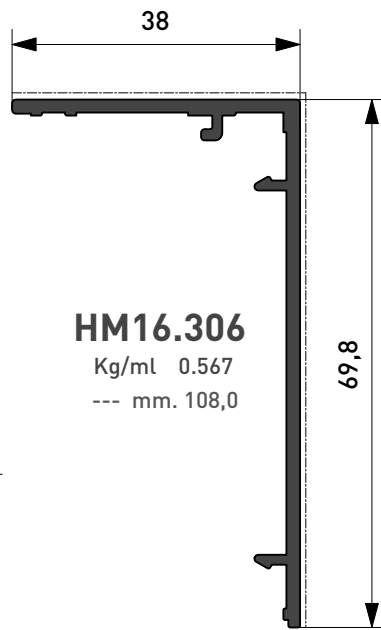

HM16.306

Kg/ml 0.567
--- mm. 108,0

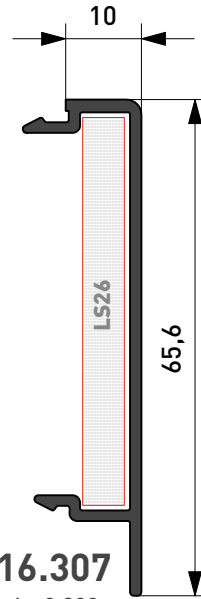

HM16.307

Kg/ml 0.390
--- mm. 76,0

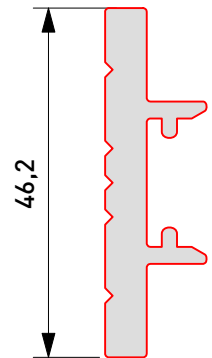

HM16.308

Kg/ml 0.788
--- mm. 000,0

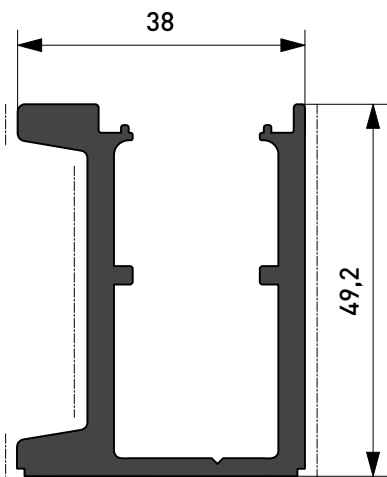

HM16.304

Kg/ml 1.355
--- mm. 124,0

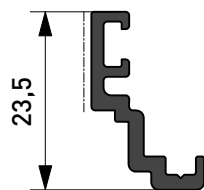

HM16.505

Kg/ml 0.215
--- mm. 18,0

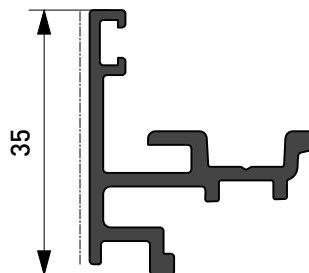

HM16.506

Kg/ml 0.497
--- mm. 35,0

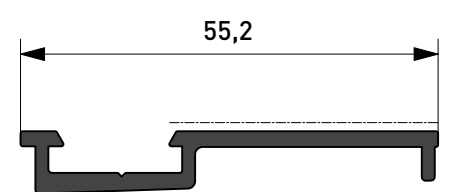

HM16.507

Kg/ml 0.414
--- mm. 35,0

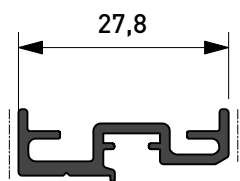

HM16.511

Kg/ml 0.221
--- mm. 18,0

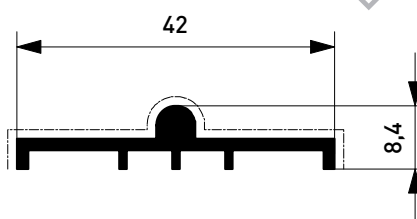

HX16.149

Kg/ml 0.267
--- mm. 54,0

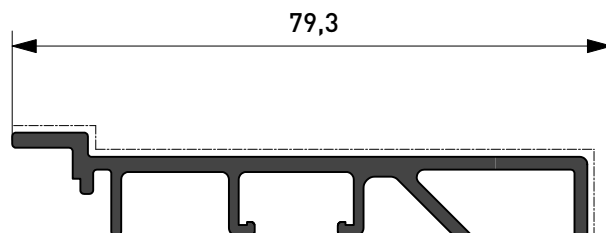

HM16.510

Kg/ml 1.220
--- mm. 156,0

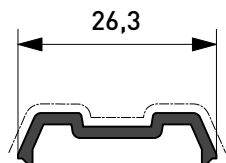

HX16.303

Kg/ml 0.146
--- mm. 32,0

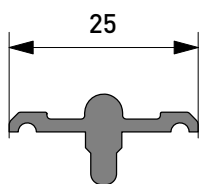

HX16.169

Kg/ml 0.231
--- mm. 22,0

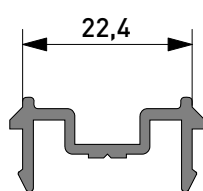

HW18.304

Kg/ml 0.224

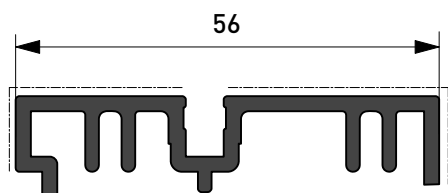

HX16.171

Kg/ml 0.688
--- mm 76,0.

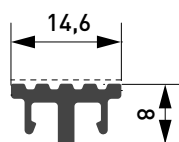

XX16.102

Kg/ml 0.140
--- mm. 14,6

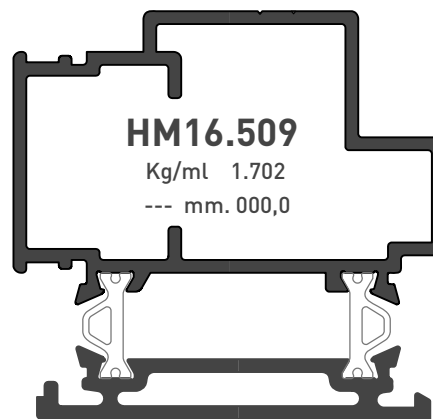

HM16.509

Kg/ml 1.702
--- mm. 000,0

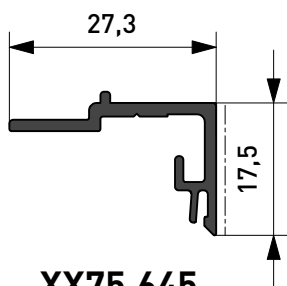

XX75.645

0.224 Kg/ml
--- mm. 000

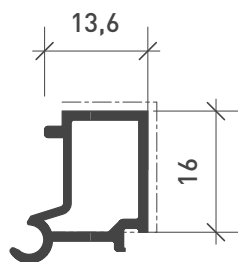

MX603.501

Kg/ml 0.216
--- mm. 30,0

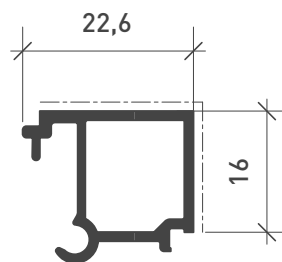

MX603.504

Kg/ml 0.256
--- mm. 39,0

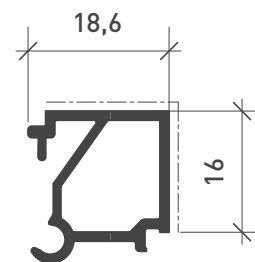

MX603.502

Kg/ml 0.244
--- mm. 35,0

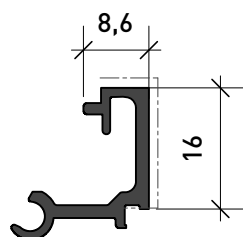

MX603.509

Kg/ml 0.210
--- mm. 25,0

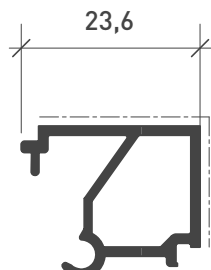

MX603.503

Kg/ml 0.259
--- mm. 40,0

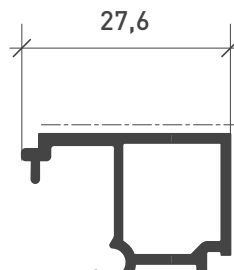

MX603.505

Kg/ml 0.276
--- mm. 44,0

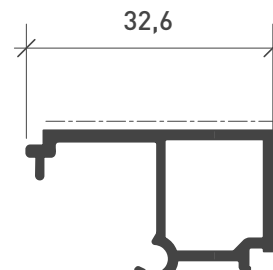

MX603.506

Kg/ml 0.297
--- mm. 49,0



Profili in Poliammide
Polyamide Profiles

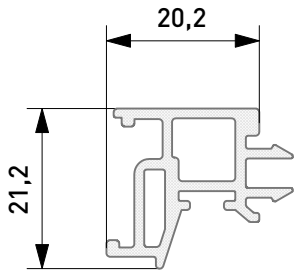

BX50

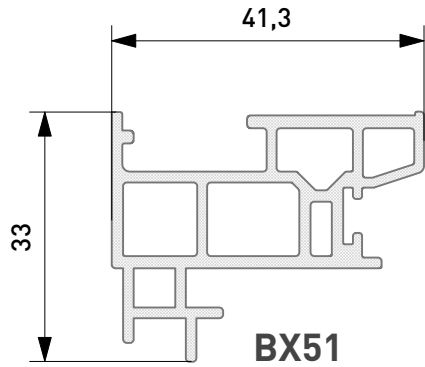

BX51

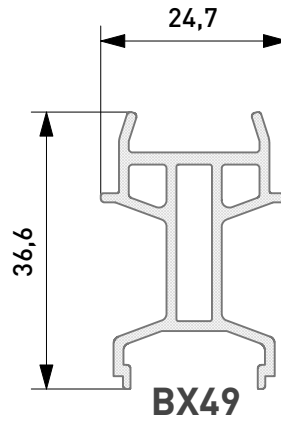

BX49

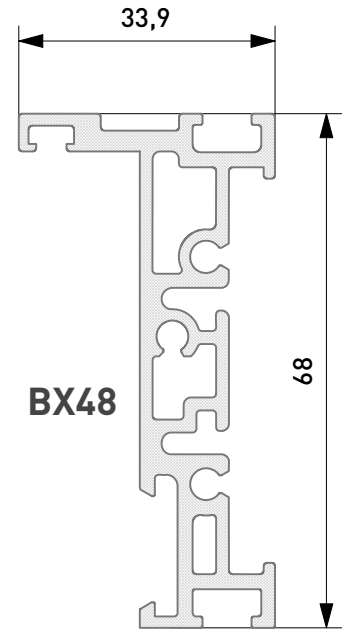

BX48

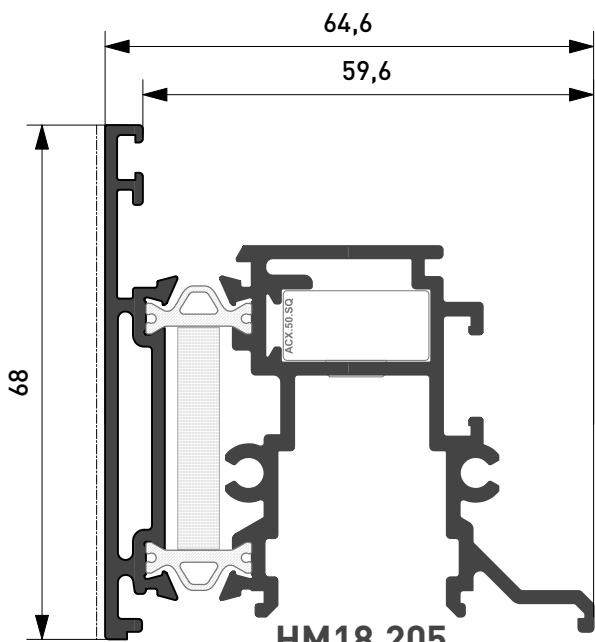

HM18.205
Kg/ml 1,826
--- mm. 73,0

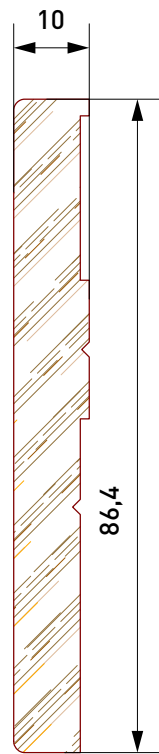

HW-C

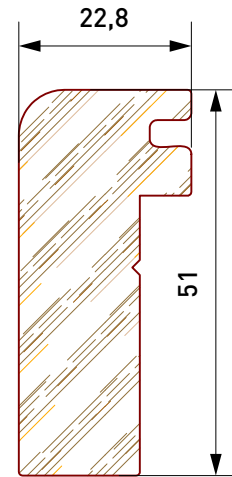

DW-A

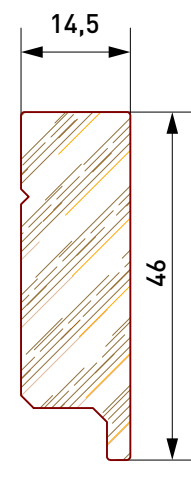

HW-D

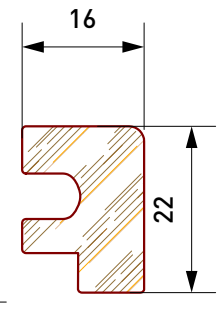

HW-E

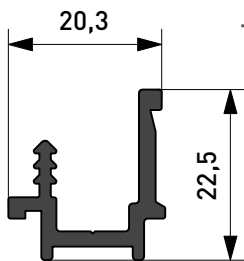

HM18.507
Kg/ml 0,305
--- mm. 00,0

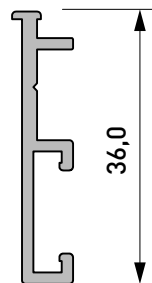

DW86.001
Kg/ml 0,258
--- mm. 00,0

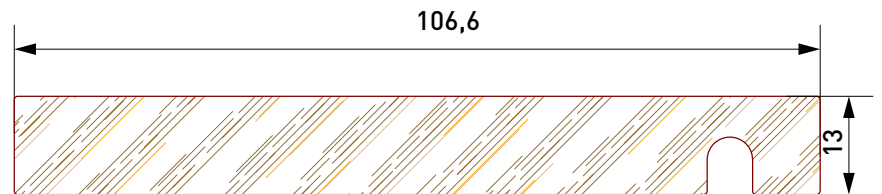

HW-F

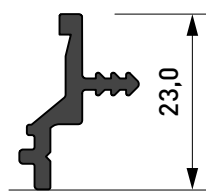

HM18.506
Kg/ml 0,212
--- mm. 00,0

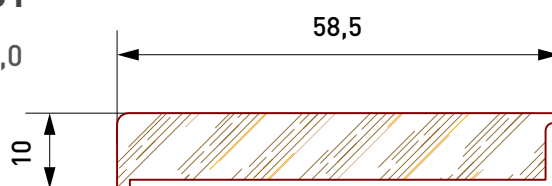

HW-G

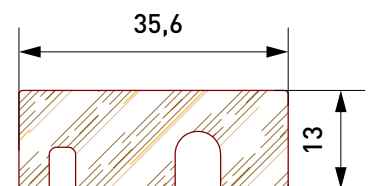

HW-H



Aletta Ext Wing	Vuoto Gap	Dim. Fermavetro Glazing Bead Dim.	Codice Fermavetro Glazing Bead CODE	Guarnizione EXT EXT Gasket	Guarnizioni interne Vetro Glass Internal Gaskets							
					ARX 10.15		ARX 10.14		ARX 10.13		ARX 10.12	
(a)	(v)	(f)			10 mm. 9 mm.		8 mm. 7 mm.		6 mm. 5 mm.		4 mm. 3 mm.	
mm.	mm.	mm.		mm.	Vetrazioni (Spessore Vetro mm.) Glazing (Glass Thickness)							
5	45	14	MX603.501	4	35	36	37	38	39	40	41	42
5	39	20	MX603.502	4	29	30	31	32	33	34	35	36
5	35	24	MX603.503	4	25	26	27	28	29	30	31	32
5	36	23	MX603.504	4	26	27	28	29	30	31	32	33
5	31	28	MX603.505	4	21	22	23	24	25	26	27	28
5	26	33	MX603.506	4	16	17	18	19	20	21	22	23
5	50	9	MX603.509	4	40	41	42	43	44	45	46	47
5	54	5	HM16.205	4	44	45	46	47	48	49	50	51

Spazio tra vetro e guarnizione (ACX10.81) considerato nelle liste di taglio = 5mm
Space between glass and gasket (ACX10.81) in the cutting list = 5mm

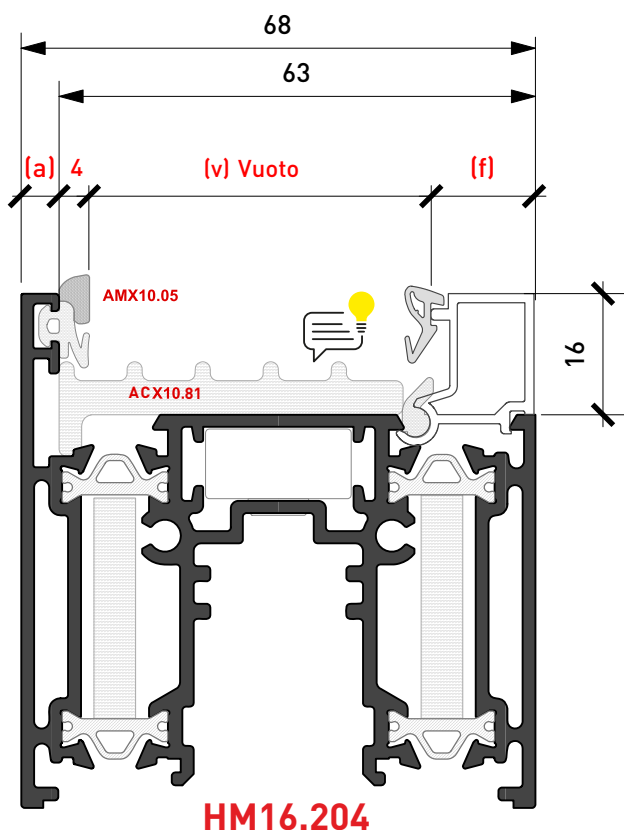

HM16.204

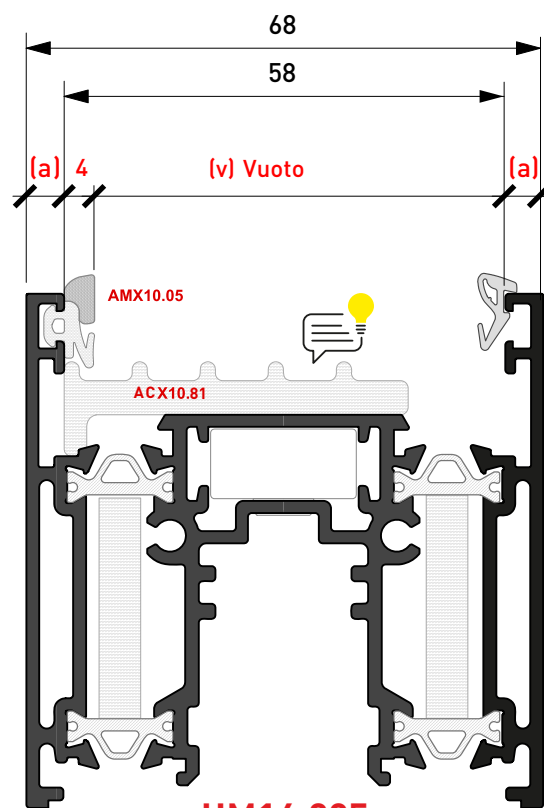

HM16.205



Gruppo C

Elenco Accessori
Elenco Guarnizioni

List of Accessories
List of Gaskets



CODIFICA FINITURE SUPERFICIALI ACCESSORI **ACCESSORIES SURFACE FINISHING CODES**

In fase di ordine aggiungere agli accessori, se previste, le seguenti codifiche superficiali:
When ordering, add the following surface codes to the accessories listed below, where applicable:

DESCRIPTION	CODICE CODE	DESCRIZIONE
PAINTED MATT BLACK	NEOPA	VERNICIATO NERO OPACO
WHITE	R 9 0 1 0	VERNICIATO BIANCO
IVORY	R 1 0 1 3	VERNICIATO AVORIO
GREEN	R 6 0 0 5	VERNICIATO VERDE
BLACK	R 9 0 0 5	VERNICIATO NERO LUCIDO
BROWN	R 8 0 1 7	VERNICIATO MARRONE
GOTHIC GREEN	G 6 3 6 0	VERNICIATO VERDE GOTICO
GOTHIC GREY	G 9 4 2 0	VERNICIATO GRIGIO GOTICO
GOTHIC BROWN	G 3 9 7 6	VERNICIATO MARRONE GOTICO
SILVER	V E A R	VERNICIATO ARGENTO
WITHERED MOSS	V S C R A	VERDE SCURO RAGGRINZITO
FALLOW	M A R A G	MARRONE RAGGRINZITO
GOLDFINISH GUNMETAL GRAY	K A N F U	CANNA DI FUCILE GOLDFINISH
GOLDFINISH COPPER	K R A M E	RAME GOLDFINISH
GOLDFINISH POLISHED	K I N O X	INOX LUCIDO GOLDFINISH
GOLDFINISH SATIN-FINISH STAINLESS STEEL	K S A T I	INOX SATINATO GOLDFINISH
GOLDFINISH GOLD	K G O L D	GOLD GOLDFINISH
GOLDFINISH ANTIQUE BRASS	K A N T I C	OTTONE ANTICO GOLDFINISH
NEW SILVER	A R G E N T	NEW ARGENTO
NEW BRONZE	B R O N Z	NEW BRONZO













ESEMPIO

AHX 3080.20 | R 9010











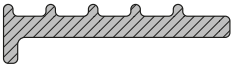
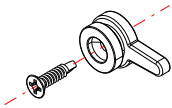
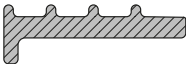

Maniglia Verniciata | COLORE Bianco Ral 9010
Painted Handle | COLOUR White RAL 9010

EXAMPLE



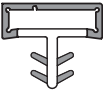
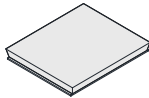

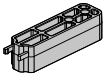
<p>ARX.10.SQ</p> <p>Descrizione Description Squadretta in materiale Plastico su Anta Plastic Sash Corner Joint</p>		<p>AMX.10.05</p> <p>Descrizione Description Guarnizione Vetro EXT Glass Gasket</p>	
<p>ARX.43.SQ</p> <p>Descrizione Description Squadretta di Allineamento Anta Sash Aling Corner Joint</p>		<p>ARX.10.12</p> <p>Descrizione Description Guarnizione Vetro INT Glass Gasket Spessore[Thickness] = 3-4 mm.</p>	
<p>AHM.70.SQ</p> <p>Descrizione Description Squadretta Interna Allineamento ANTA Internal SASH Aling Corner Joint</p>		<p>ARX.10.13</p> <p>Descrizione Description Guarnizione Vetro INT Glass Gasket Spessore[Thickness] = 5-6 mm.</p>	
<p>ACX.16.SQ</p> <p>Descrizione Description Squadretta a pulsante Button Corner Joint 17.5 mm x 15 mm Foro(Hole)=8 mm</p>		<p>ARX.10.14</p> <p>Descrizione Description Guarnizione Vetro INT Glass Gasket Spessore[Thickness] = 7-8 mm.</p>	
<p>ACX.50.SQ</p> <p>Descrizione Description Squadretta a bottone Button Corner Joint 19.3 mm x 9.2 mm Foro(Hole)=8 mm</p>		<p>ARX.10.15</p> <p>Descrizione Description Guarnizione Vetro INT Glass Gasket Spessore[Thickness] = 9-10 mm.</p>	
<p>ACX.51.SQ</p> <p>Descrizione Description Squadretta Cianfrinare/Spinare Riveting/Crimping Corner Joint 19.4 mm x 9.3 mm</p>		<p>AHX 10.47</p> <p>Descrizione Description Guarnizione Superiore Anta Upper Sash Gasket</p>	
<p>ACX.53.SQ</p> <p>Descrizione Description Spina inox Squadretta ACX.51.SQ INOX plug for ACX.51.SQ Corner Joint</p>		<p>AHX 10.48</p> <p>Descrizione Description Guarnizione Perimetrale Anta Perimetral Sash Gasket</p>	
<p>ACX.06.04</p> <p>Descrizione Description Registro Z/P Z/P Adjusting Screw</p>		<p>AHX 10.63</p> <p>Descrizione Description Guarnizione Inferiore Anta Lower Sash Gasket</p>	



ACX 10.71 Descrizione Description Guarnizione a Compressione Fermavetro <i>Glass Holder Push Gasket</i>		ASX 10.69 Descrizione Description Guarnizione di tenuta per anta <i>Sealing gasket for Sash</i>	
ACX 10.81 Descrizione Description Guarnizione Sotto Vetro (Vetro 42 mm) <i>Under Glass Window Gasket</i>		AWX 06.04 Descrizione Description Nottolino Per fissaggio AHM 18.205 e DW 86.001 <i>Fixing Pawl for AHM 18.205 and DW 86.001</i>	
ACX 10.82 Descrizione Description Guarnizione Sotto Vetro (Vetro 36mm) <i>Under Glass Window Gasket</i>		ASX 05.02 Descrizione Description Boccola di Drenaggio <i>Drainage Bush</i>	
AHX 10.64 Descrizione Description Guarnizione Autoadesiva Riporto Centrale 90° <i>Self-adhesive 90° Central Mullion Gasket</i> Dim. 14 X10 mm.		ASX 16.21 Descrizione Description Copricilindro di sicurezza "ITALIA" <i>"ITALIA" safety cylinder cover</i>	
AHM10.65 Descrizione Description Guarnizione Autoadesiva Riporto Centrale 45° <i>Self-adhesive 45° Central Mullion Gasket</i> Dim. 14 X13 mm.		AHM16.01 Descrizione Description Supp. Doghe SOGLIA FILOPAVIMENTO <i>FLOORLEVEL THRESHOLD Beds Support</i> 100x50 mm. Conf = 25 pz. / Pack. = 25 pcs.	
AWX 10.20 Descrizione Description Guarnizione Legno <i>Gasket for Wood</i>		AHM 10.93 Descrizione Description Spugna Nodo Centrale Soglia Ribassata <i>Sponge for Central Node Low Threshold</i> 49 X 40 X 5 mm.	
AWX 10.21 Descrizione Description Guarnizione int. profilo di sicurezza <i>Internal Gasket</i>		AHX10.95 Descrizione Description Spessore Unione HM16.204 e HM16.510 <i>Spacer for HM16.204 and HM16.510 joint</i> h. 22 mm.	
AWX 10.36 Descrizione Description Guarnizione FERMAVETRO Legno <i>Gasket for GLASS HOLER Wood</i>			



LS 02	
Descrizione Description	
Listello Isolante	
Insulating Shim	
Dim. 35 x 15 mm.	

AHX 3080.20		
Descrizione Description		
Maniglia Alzante + Vaschetta Traino		
Handle for Lifting Window w/ Washer		
Rosette 10 mm.		

linea ITALIA

LS 09	
Descrizione Description	
Listello Isolante Adesivo	
Insulating Shim Adhesive	
Dim. 5 x 28 mm.	

AHX 3080.25		
Descrizione Description		
Doppia Maniglia Alzante		
Double Handle for Lifting Window		
Rosette 10 mm.		

linea ITALIA

LS 26	
Descrizione Description	
Listello Isolante	
Insulating Shim	
Dim. 5 x 49 mm.	

AHM 10.94		
Descrizione Description		
Ammortizzatore Serratura		
Locker Stopper		

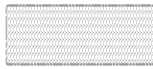
LS 40	
Descrizione Description	
Listello Isolante	
Insulating Shim	
Dim. 30 x 15 mm.	

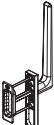
AHM 3081.20		
Descrizione Description		
Maniglia Alzante + Vaschetta Traino		
Handle for Lifting Window + Washer		
Rosette 10 mm.		

linea KARMA

LS 51	
Descrizione Description	
Listello Isolante	
Insulating Shim	
Dim. 25 x 5 mm.	

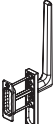
AHM 3081.30		
Descrizione Description		
Maniglia Alzante c/Chiave + Vaschetta Traino		
Handle for Lifting Window w/ Lock Key + Washer		
Rosette 10 mm.		

linea KARMA

AHM 16.6734.1		
Descrizione Description		
Riscontro singolo		
Adjustable Lock Striker extra		

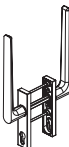
AHM 3081.35		
Descrizione Description		
Doppia Maniglia Alzante		
Double Handle for Lifting Window		
Rosette 10 mm.		

linea KARMA



Tipo A | *A Type*

Tipo F | *F Type*

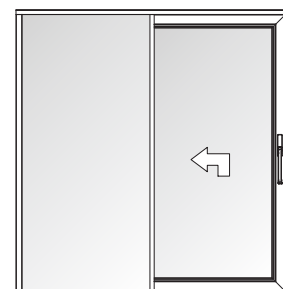
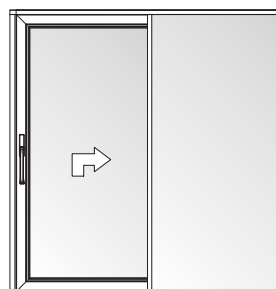

CONFEZIONE KIT
VETRATA FISSA+ ANTA 90° MOBILE
FIX GLAZING + 90° MOBILE SASH PACK

AHM 16.6745.68

KIT Carrelli *KIT Track Roller*

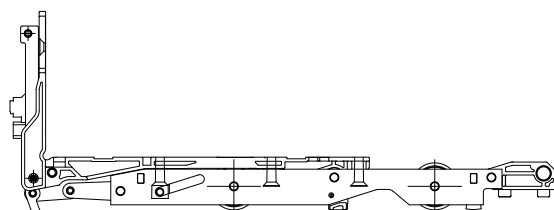

250 Kg Portata MAX
250 Kg MAX Weight

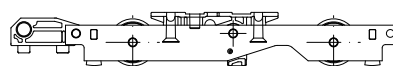

KIT Basamenti per Montanti *KIT Mullion Basement Caps*

Tappi Superiori
Upper Caps

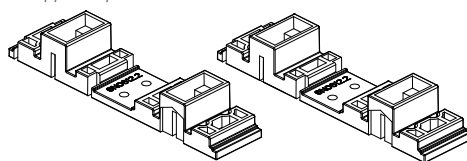

Tappi Inferiori
Lower Caps

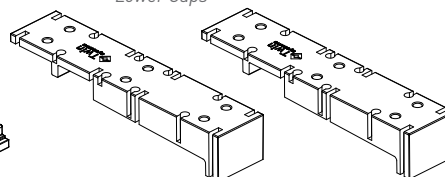

KIT Tappi Centrali Sup +Inf *KIT Sup + Inf Central Caps*

Tappi Superiori *Upper Caps*

Angoli Guarnizioni
Corner Gaskets

AHX10.47



Tappo Sup. Riporto Centrale + Spazzolino + Cover
Upper Central Joint Cap + Brush + Cover

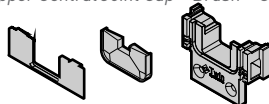

Tappo BX50
BX50 Cap

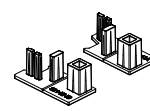

Tappi Inferiori *Lower Caps*

Angoli Guarnizioni
Corner Gaskets

AHX10.63



Tappo Inf. Riporto Centrale + Spugna + Cover
Bottom Central Joint Cap + Sponge + Cover

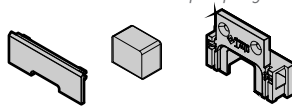

Tappo Profilo HM16.304
Profile HM16.304 Cap

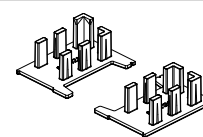

KIT Tenuta Centrale + Bumper *KIT Central Sealing + Bumper*

Tappo di tenuta per Montante Centrale
[Lato Fisso]
Central Sealing for Mullion
[Fix Side]

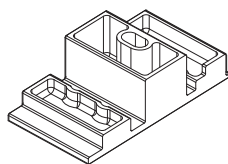

Spugna Inferiore Telaio Lato Serratura
Lower Frame Sponge [Latch Side]



Bumper
Bumper



Coppia Tappi Inferiore Centrale per BX48
[Anta Fissa] DX/SX
Under Mullion Cap Couple for BX48
[Central Side Fixed Sash] RX-LX

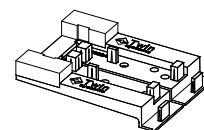



Tipo A | A Type

Tipo F | F Type

CONFEZIONE KIT CLIPS VETRATA FISSA+ ANTA MOBILE 90°
FIX GLAZING + MOBILE 90° SASH CLIPS KIT

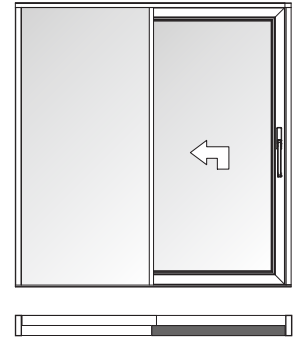
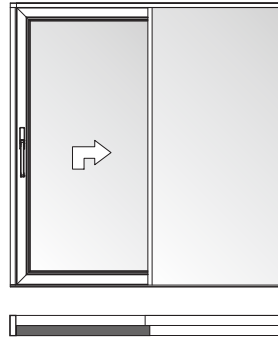

AHM 16.6745.72

KIT Clips

KIT Clips

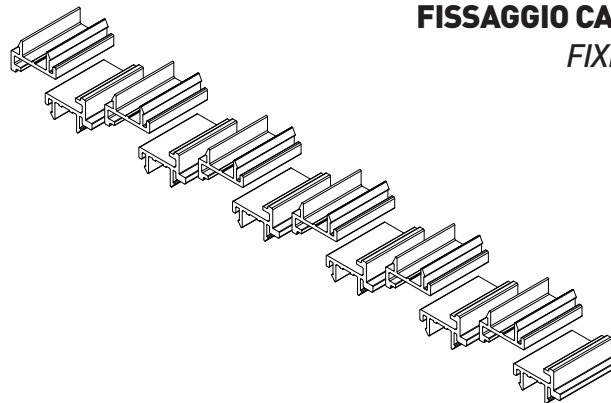

FISSAGGIO CARTER SUPERIORE HM16.503
FIXING UPPER CARTER HM16.503

6 Cp.







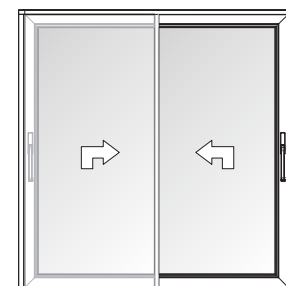
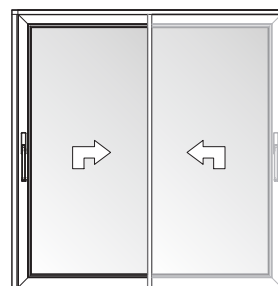

Tipo C | C Type

Tipo H | H Type

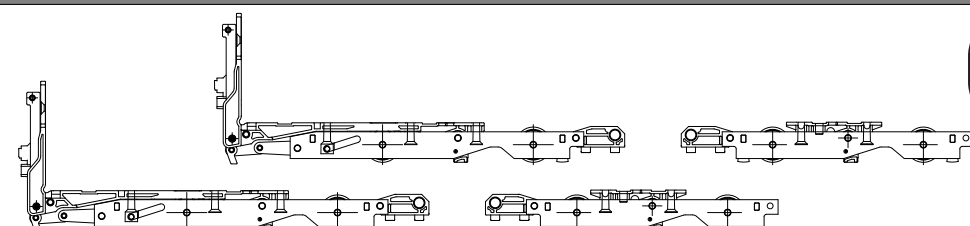
CONFEZIONE KIT 2 ANTE 90° MOBILI
2 SLIDING 90° SASHES PACK

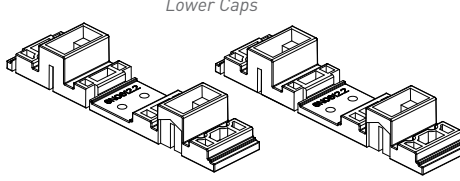
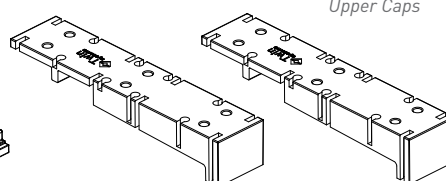

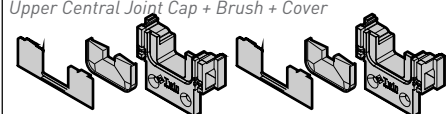
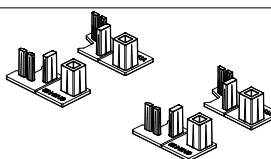
AHM 16.6745.69

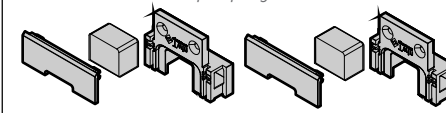
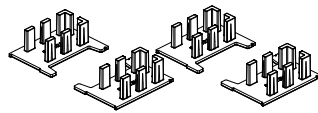
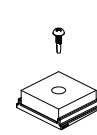
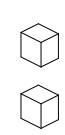
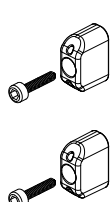
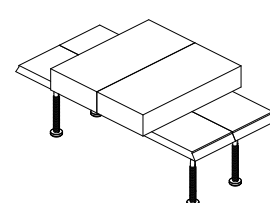
KIT Carrelli <i>KIT Track Roller</i>	
 <div style="float: right; border: 1px solid black; border-radius: 15px; padding: 5px;">  250 Kg Portata MAX 250 Kg MAX Weight </div>	
KIT Basamenti per Montanti <i>KIT Mullion Basement Caps</i>	
Tappi Inferiori <i>Lower Caps</i> 	Tappi Superiori <i>Upper Caps</i> 
KIT Tappi Centrali Sup + Inf <i>KIT Sup + Inf Central Caps</i>	
Tappi Superiori <i>Upper Caps</i>	
Angoli Guarnizioni <i>Corner Gaskets</i> AHX10.47 	Tappo Sup. Riporto Centrale + Spazzolino + Cover <i>Upper Central Joint Cap + Brush + Cover</i> 
	Tappo BX50 <i>BX50 Cap</i> 
Tappi Inferiori <i>Lower Caps</i>	
Angoli Guarnizioni <i>Corner Gaskets</i> AHX10.48 	Tappo Inf. Riporto Centrale + Spugna + Cover <i>Bottom Central Joint Cap + Sponge + Cover</i> AHX10.63 
	Tappo Profilo HM16.304 <i>Profile HM16.304 Cap</i> 
KIT Tenuta Centrale + Bumper <i>KIT Central Sealing + Bumper</i>	
Tassello Tenuta Centrale Inferiore <i>Lower Central Sealing Raw Plug</i> 	Spugna Inferiore Telaio Lato Serratura <i>Lower Frame Sponge [Latch Side]</i> 
	Bumper 
	Tassello Tenuta Centrale Superiore <i>Upper Central Sealing Raw Plug</i> 



CONFEZIONE KIT 2 ANTE 45° MOBILI
2 MOBILE 45° SASHES PACK

Tipo D | *D Type*

Tipo I | *I Type*

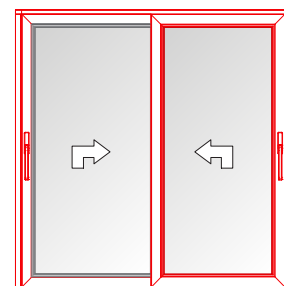
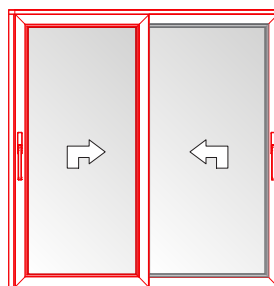

AHM 16.6745.70

KIT Carrelli *KIT Track Roller*

250 Kg Portata MAX
250 Kg MAX Weight

KIT Basamenti per Montanti *KIT Mullion Basement Caps*

Tappi Superiori
Upper Caps

Tappi Inferiori
Lower Caps

KIT Tappi Centrali Sup +Inf *KIT Sup + Inf Central Caps*

<p>Tappi Superiori <i>Upper Caps</i></p> <p>Angoli Guarnizioni <i>Corner Gaskets</i></p> <p>AHX10.47</p>	<p>Tappo Sup. Riporto Centrale + Spazzolino + Cover <i>Upper Central Joint Cap + Brush + Cover</i></p>	<p>Tappo SUP per BX51 <i>BX51 Cap</i></p>
<p>Tappi Inferiori <i>Lower Caps</i></p> <p>Angoli Guarnizioni <i>Corner Gaskets</i></p> <p>AHX10.48 AHX10.63</p>	<p>Tappo Inf. Riporto Centrale + Spugna + Cover <i>Bottom Central Joint Cap + Sponge + Cover</i></p>	<p>Tappo INF per BX51 <i>BX51 Cap</i></p>

KIT Tenuta Centrale + Bumper *KIT Central Sealing + Bumper*

<p>Tassello Tenuta Centrale Inferiore <i>Lower Central Sealing Raw Plug</i></p>	<p>Spugna Inferiore Telaio Lato Serratura <i>Lower Frame Sponge [Latch Side]</i></p>	<p>Bumper</p>	<p>Tassello Tenuta Centrale Superiore <i>Upper Central Sealing Raw Plug</i></p>
--	---	----------------------	--



CONFEZIONE KIT 1 ANTE 45° MOBILE + Anta 45° FISSA
1 MOBILE 45° + 1 FIXED 45° SASHE PACK

Tipo B | B Type

Tipo G | G Type

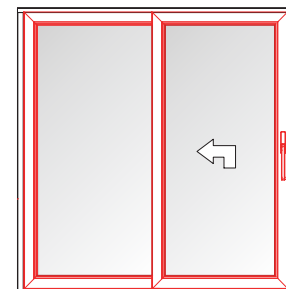
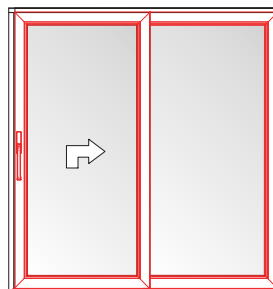

AHM 16.6745.76

<p>KIT Carrelli + Distanziatori <i>KIT Track Roller + Spacers</i></p> <div style="border: 1px solid black; border-radius: 15px; padding: 5px; display: inline-block;"> <p>250 Kg Portata MAX <i>250 Kg MAX Weight</i></p> </div>			
<p>KIT Basamenti per Montanti <i>KIT Mullion Basement Caps</i></p> <div style="display: flex; justify-content: space-around;"> <div style="text-align: center;"> <p>Tappi Superiori <i>Upper Caps</i></p> </div> <div style="text-align: center;"> <p>Tappi Inferiori <i>Lower Caps</i></p> </div> </div>			
<p>KIT Tappi Centrali Sup + Inf <i>KIT Sup + Inf Central Caps</i></p>			
<p>Tappi Superiori <i>Upper Caps</i></p> <p>Angoli Guarnizioni <i>Corner Gaskets</i></p> <p>AHX10.47</p>	<p>Tappo Sup. Riporto Centrale + Spazzolino + Cover <i>Upper Central Joint Cap + Brush + Cover</i></p>	<p>Tappo SUP per BX51 <i>BX51 Cap</i></p>	
<p>Tappi Inferiori <i>Lower Caps</i></p> <p>Angoli Guarnizioni <i>Corner Gaskets</i></p> <p>AHX10.48 AHX10.63</p>	<p>Tappo Inf. Riporto Centrale + Spugna + Cover <i>Bottom Central Joint Cap + Sponge + Cover</i></p>	<p>Tappo INF per BX51 <i>BX51 Cap</i></p>	
<p>KIT Tenuta Centrale + Bumper <i>KIT Central Sealing + Bumper</i></p>			
<p>Tassello Tenuta Centrale Inferiore <i>Lower Central Sealing Raw Plug</i></p>	<p>Spugna Inferiore Telaio Lato Serratura <i>Lower Frame Sponge [Latch Side]</i></p>	<p>Bumper</p>	<p>Tassello Tenuta Centrale Superiore <i>Upper Central Sealing Raw Plug</i></p>



Tipo E | E Type

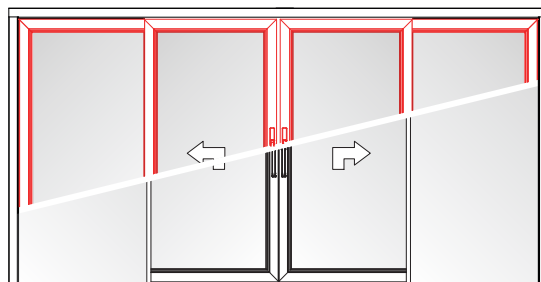

CONFEZIONE 2 ANTE MOBILI 90° + 2 VETRATE FISSE
2 90° SLIDING SASHES + 2 FIX GLAZING KIT

CONFEZIONE 2 ANTE MOBILI 90° + 2 ANTE FISSE
2 45° SLIDING SASHES + 2 FIXED SASHES KIT

CONFEZIONE 2 ANTE MOBILI 45° + 2 ANTE FISSE
2 45° SLIDING SASHES + 2 FIXED SASHES KIT

AHM 16.6745.71

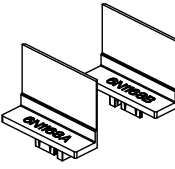
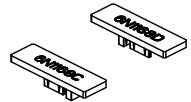
KIT 4 Ante	KIT 4 Sashes
<p>Tappo Superiore HM16.511 <i>Upper Cap HM16.511</i></p> 	<p>Tappo Inferiore HM16.511 <i>Bottom Cap HM16.511</i></p> 

NB. Da abbinare a
To be paired with

90° Fisso+Vetrata **2 KIT HM16.6745.68**
90° Glazing Panel + Mobile Sash

90° Fisso+Mobile **2 KIT HM16.6745.77**
90° Fixed Sash + Mobile Sash

45° Fisso+Mobile **2 KIT HM16.6745.76**
45° Fixed Sash + Mobile Sash



CONFEZIONE ANGOLO 2 ANTE MOBILE + ANTE FISSE 45°
2 45° SLIDING SASHES + 2 FIXED SASHES CORNER PACK

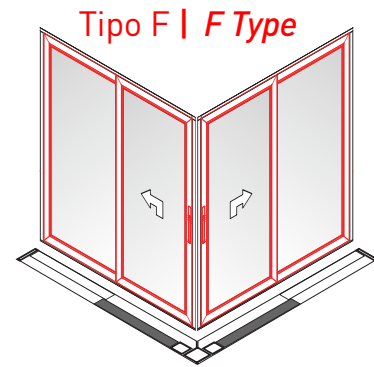

AHM 16.6745.74

KIT Angolo		KIT Corner	
<p>Tappo Superiore HM16.510 + Spazzolini <i>Upper Cap HM16.510 + Brushes</i></p> <p>SX DX LX RX</p>	<p>Tappo Inferiore HM16.510 + Spugnetta <i>Bottom Cap HM16.510 + Sponge</i></p> <p>SX DX LX RX</p>		

NB. Da abbinare a
To be paired with

45° Fisso+Mobile
45° Fixed Sash + Mobile Sash

2 KIT HM16.6745.76



Tipo L | *L Type*

CONFEZIONE KIT 1 ANTa 45° ad INCASSO
1 MOBILE 45° SASH FOLDABLE

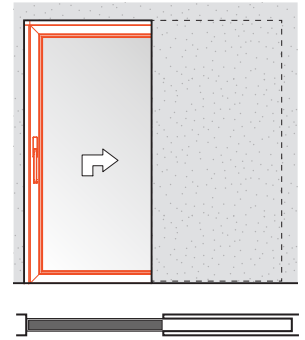

AHM 16.6745.75

KIT Carrelli		KIT Track Roller	
		250 Kg Portata MAX <i>250 Kg MAX Weight</i>	
KIT Tappi Centrali Sup +Inf		KIT Sup + Inf Central Caps	
Tappi Superiori <i>Upper Caps</i>	Angoli Guarnizioni <i>Corner Gaskets</i>	Tappo Finitura Anta <i>Sash Finishing Cap</i>	Tappo Sup. Riporto Centrale +Spazzolino + Cover <i>Upper Central Joint Cap + Brush + Cover</i>
	AHX10.47		
Tappi Inferiori <i>Lower Caps</i>	Angoli Guarnizioni <i>Corner Gaskets</i>		Tappo Inf. Riporto Centrale + Spugna + Cover <i>Bottom Central Joint Cap +Sponge + Cover</i>
	AHX10.48 AHX10.63		



Tipo M | *M Type*

Tipo N | *N Type*

CONFEZIONE KIT 2 ANTE MIN FISSO + MOBILE
2 SASHES MIN SASHES PACK

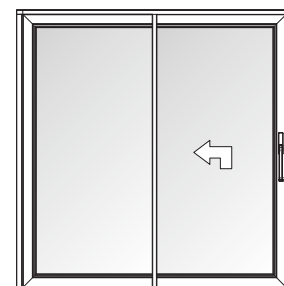
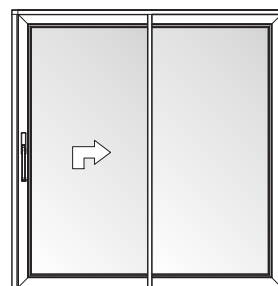

AHM 16.6745.77



KIT Carrelli + Distanziatori *KIT Track Roller + Spacers*

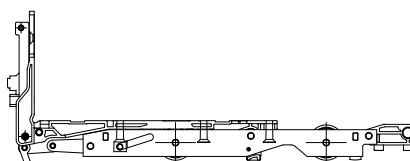
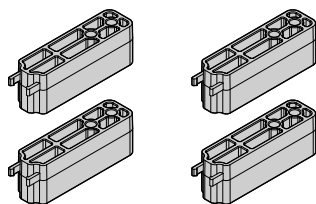

 **250 Kg Portata MAX**
250 Kg MAX Weight

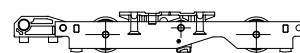

KIT Basamenti per Montanti *KIT Mullion Basement Caps*

Tappi Inferiori
Lower Caps

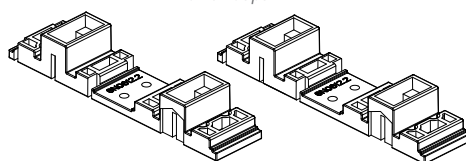

Tappi Superiori
Upper Caps

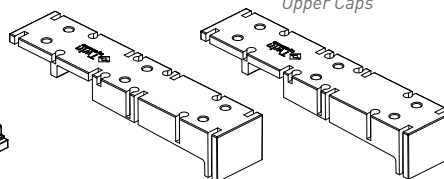

KIT Tappi Centrali Sup + Inf *KIT Sup + Inf Central Caps*

Tappi Superiori *Upper Caps*

Angoli Guarnizioni *Corner Gaskets*

AHX10.47



Tappo Sup. Riporto Centrale + Spazzolino + Cover
Upper Central Joint Cap + Brush + Cover

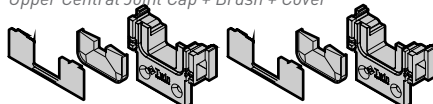

Tappo BX50
BX50 Cap

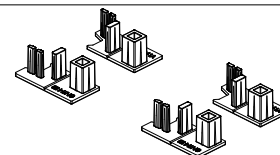

Tappi Inferiori *Lower Caps*

Angoli Guarnizioni *Corner Gaskets*

AHX10.48



AHX10.63

Tappo Inf. Riporto Centrale + Spugna + Cover
Bottom Central Joint Cap + Sponge + Cover

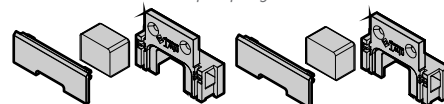

Tappo Profilo HM16.304 *Profile HM16.304 Cap*

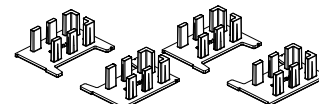

KIT Tenuta Centrale + Bumper *KIT Central Sealing + Bumper*

Tassello Tenuta Centrale Inferiore
Lower Central Sealing Raw Plug

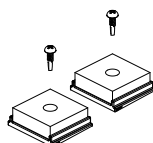

Spugna Inferiore Telaio Lato Serratura
Lower Frame Sponge [Latch Side]

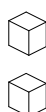

Bumper

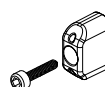

Tassello Tenuta Centrale Superiore
Upper Central Sealing Raw Plug

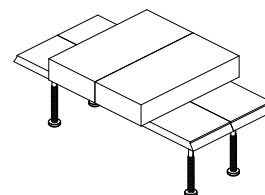



TUTTI TIPI A 2 ANTE
ALL 2 SASHES TYPES

Tipo | Type **A/B** Tipo | Type **D/F**

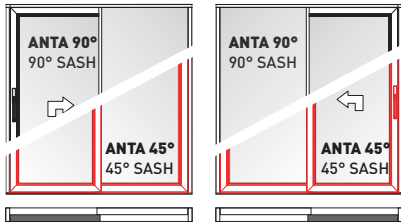

Tipo | Type **C/D** Tipo | Type **H/I**

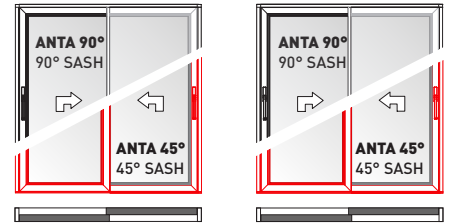

AHM 16.6740.12

KIT Carrelli Supplementari + Ammortizzatore

KIT Additional Track Roller + Cremona DUMPER

Coppia Carrelli Supplementari
Additional Track Roller Pair

1 cp.

 **400 Kg Portata MAX**
400 Kg MAX Weight

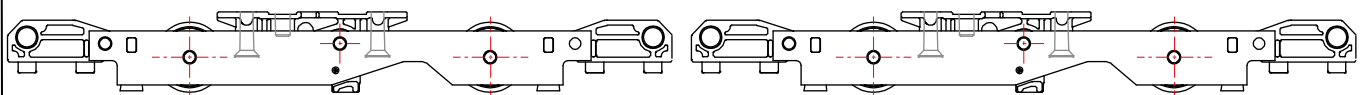
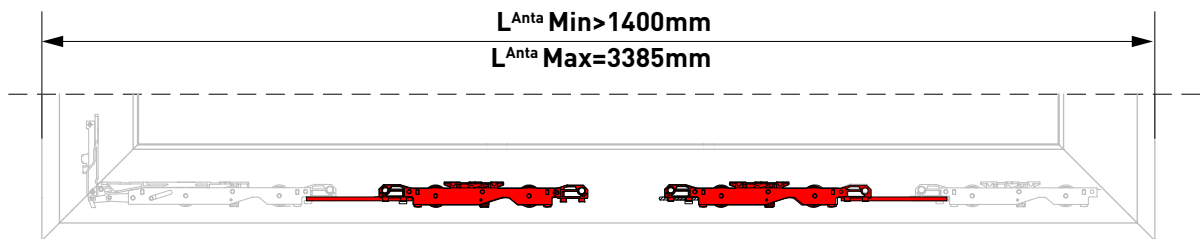

Asta Collegamento Carrelli Supplementari

Connection Rod
2 pz.

Asta Collegamento Carrelli **AHX6741.X**

CARRELLO SUPPLEMENTARE

Asta nel KIT **AHM6740.12 L=96mm.**

CARRELLO PRINCIPALE

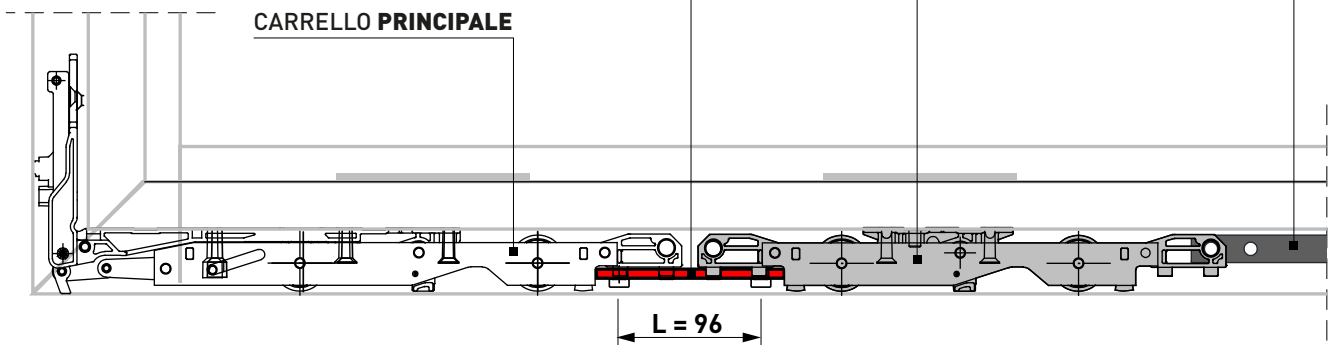

Ammortizzatore Serratura OBBLIGATORIO

MANDATORY Cremona Dumper

1 pz.





ASTA DI COLLEGAMENTO
Track Roller Connection Rod

CAMPO DI APPLICAZIONE HS CARRELLO 250Kg/400kg
FIELD OF APPLICATION HS TROLLEY 250Kg/400kg

AHX 6741.X		UTILIZZO SINGOLO 250 Kg	UTILIZZO TANDEM 400 Kg <i>TANDEM USE 400 Kg</i>
Descrizione Description		Asta VERTICALE VERTICAL Rod	Asta VERTICALE VERTICAL Rod
Asta di Collegamento Carrelli <i>Track Roller Connectin Beam</i>	L Asta <i>Rod LENGHT</i>	$L = L_{Anta} - 662$ Anta/Sash	$L = L_{Anta} - 1187$ Anta/Sash
AHX 6741.1	L= 692	714 - 1314	1279 - 1879
AHX 6741.2	L=1196	1218 - 1818	1783 - 2383
AHX 6741.3	L=1700	1722 - 2322	2287 - 2887
AHX 6741.4	L=2204	2226 - 2826	2791 - 3391
AHX 6741.5	L=2708	2730 - 3330	3295 - 3895

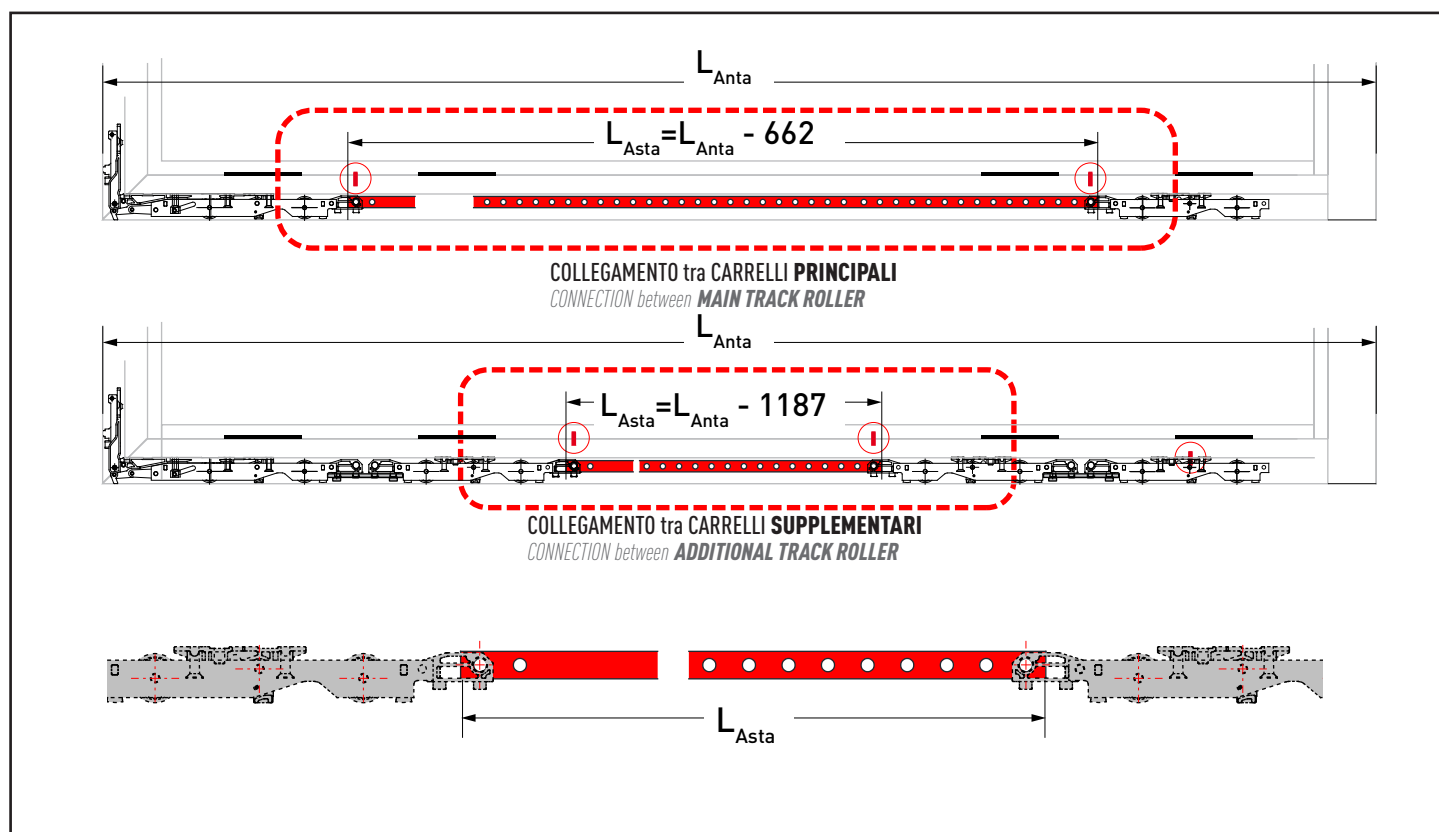
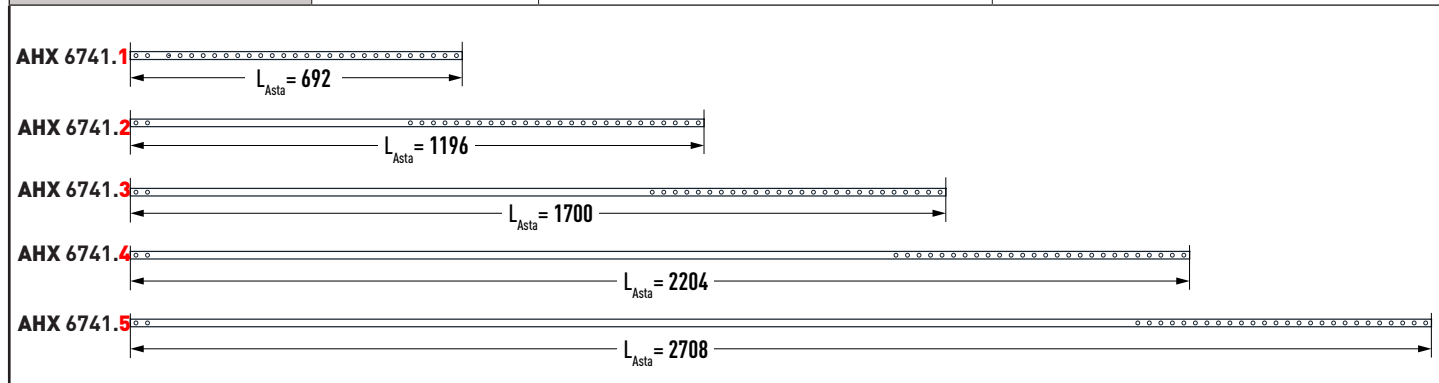



TUTTI I TIPI [ANTA 45°+ MIN]
ALL TYPES [45°+ MIN SASH]

Tipo | Type **A/B** Tipo | Type **D/F**

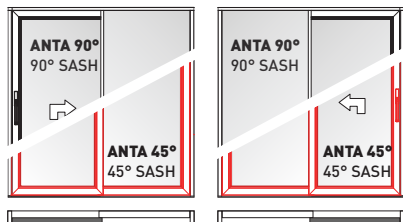

Tipo **E** | **E Type**

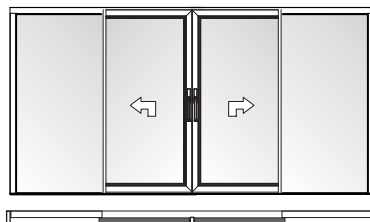

Tipo | Type **C/D** Tipo | Type **H/I**

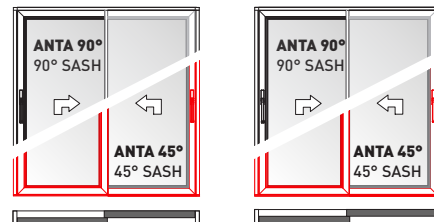

AHM 16.6744.2

KIT Rallentatore Corsa

KIT Rallenty



Art. OPZIONALE - vedere tavola "G53"
OPTIONAL item - see page "G53"



Max 300 Kg/Anta
300 Kg/Sash Max

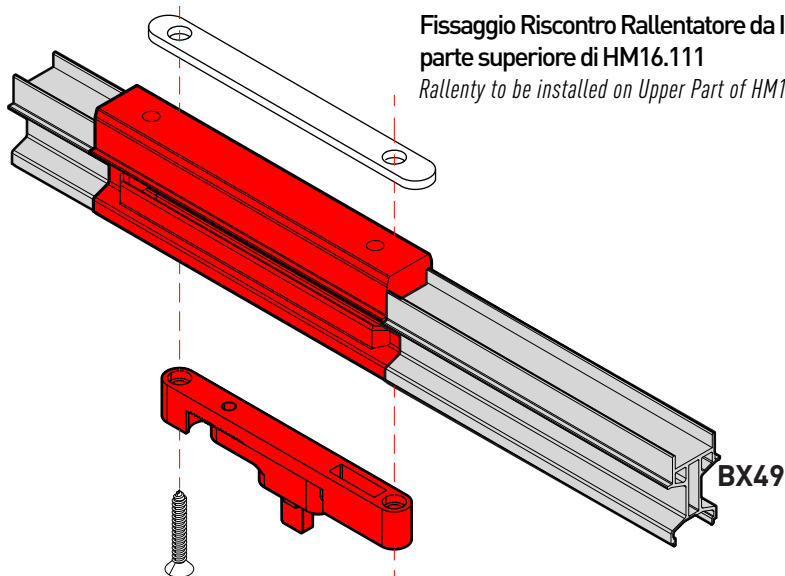

Fissaggio Riscontro Rallentatore da installare sulla parte superiore di HM16.111

Rallenty to be installed on Upper Part of HM16.111

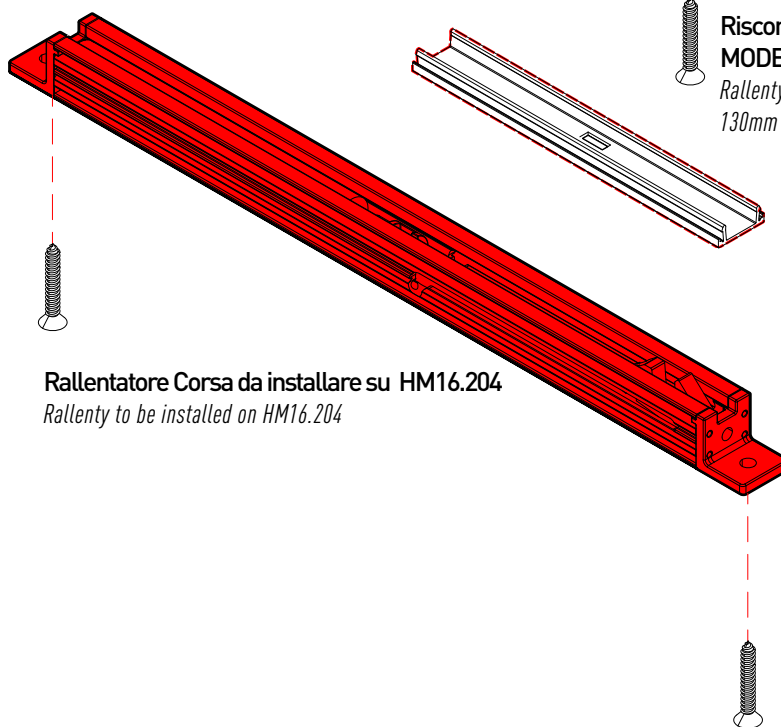

Riscontro Rall. Corsa da installare su PARTE MODELLATA di BX49 da 130 mm BAR

Rallenty Stopper to be installed on BX49 MODELED 130mm BAR

Rallentatore Corsa da installare su HM16.204
Rallenty to be installed on HM16.204



AHM 16.6744.2 NON INCLUDE PORZIONE DI ASX10.26. Viteria Inclusa
AHM 16.6744.2 DOES NOT INCLUDE ASX10.26. Fixing Screws Included



TUTTI I TIPI [ANTA 45°+ MIN]
ALL TYPES [45°+ MIN SASH]

Tipo | Type **A/B** Tipo | Type **D/F**

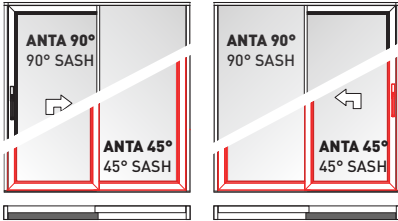

Tipo **E** | **E Type**

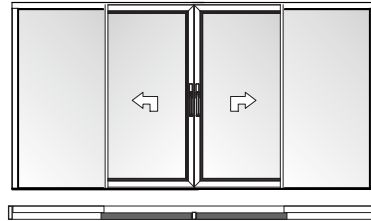

Tipo | Type **C/D** Tipo | Type **H/I**

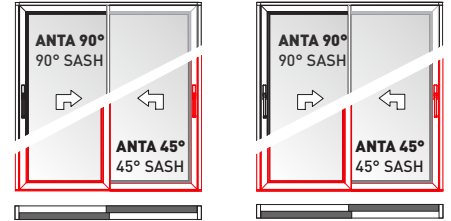

AHM 16.6745.73

KIT ANTIEFFRAZIONE

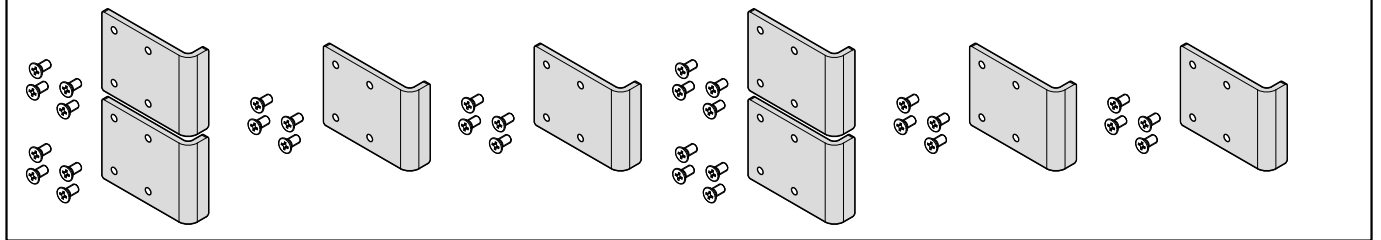



TUTTI TIPI A 2 ANTE
ALL 2 SASHES TYPES

Tipo | Type **A/B** Tipo | Type **D/F**

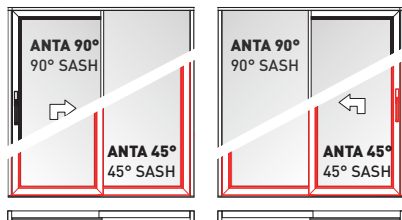

Tipo | Type **C/D** Tipo | Type **H/I**

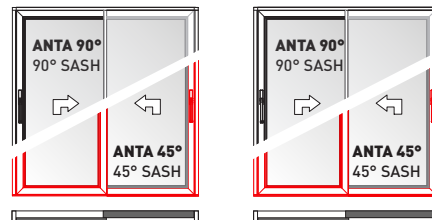

KIT AHM16.6732.XX

KIT Serratura	KIT Latch	AHM16.6732.2	Qt.
		Scontro Regolabile <i>Adjustable Lock Striker</i>	2 pz.
		Serratura alzante <i>Latch for Lifting Sliding Window 2 Hooks</i>	1 pz.
		H Maniglia <i>H Handle</i>	400 mm.
		H Anta <i>H Sash</i>	735/1305 mm.
		L Asta <i>L Rod</i>	1305 mm.
		AHM16.6732.3	Qt.
		Scontro Regolabile <i>Adjustable Lock Striker</i>	2 pz.
		Serratura alzante <i>Latch for Lifting Sliding Window 2 Hooks</i>	1 pz.
		H Maniglia <i>H Handle</i>	400 mm.
		H Anta <i>H Sash</i>	1235/1960 mm.
		L Asta <i>L Rod</i>	1900 mm.
		AHM16.6732.4	Qt.
		Scontro Regolabile <i>Adjustable Lock Striker</i>	2 pz.
		Serratura alzante <i>Latch for Lifting Sliding Window 2 Hooks</i>	1 pz.
		H Maniglia <i>H Handle</i>	1000 mm.
		H Anta <i>H Sash</i>	1835/2560 mm.
		L Asta <i>L Rod</i>	2500 mm.
		AHM16.6732.5	Qt.
	Scontro Regolabile <i>Adjustable Lock Striker</i>	3 pz.	
	Serratura alzante <i>Latch for Lifting Sliding Window 2 Hooks</i>	1 pz.	
	H Maniglia <i>H Handle</i>	1000 mm.	
	H Anta <i>H Sash</i>	2270/2860 mm.	
	L Asta <i>L Rod</i>	2800 mm.	
	AHM16.6732.6	Qt.	
	Scontro Regolabile <i>Adjustable Lock Striker</i>	3 pz.	
	Serratura alzante <i>Latch for Lifting Sliding Window 2 Hooks</i>	1 pz.	
	H Maniglia <i>H Handle</i>	1000 mm.	
	H Anta <i>H Sash</i>	2670/3360 mm.	
	L Asta <i>L Rod</i>	3300 mm.	
	AHM16.6732.7	Qt.	
	Scontro Regolabile <i>Adjustable Lock Striker</i>	3 pz.	
	Serratura alzante <i>Latch for Lifting Sliding Window 2 Hooks</i>	1 pz.	
	H Maniglia <i>H Handle</i>	1000 mm.	
	H Anta <i>H Sash</i>	2670/3860 mm.	
	L Asta <i>L Rod</i>	3800 mm.	



Tipo C | C Type

CONFEZIONE KIT 2 ANTE MOBILE 90° + 2 VETRATE FISSE
2 90° SLIDING SASHES + 2 FIX GLAZING PACK

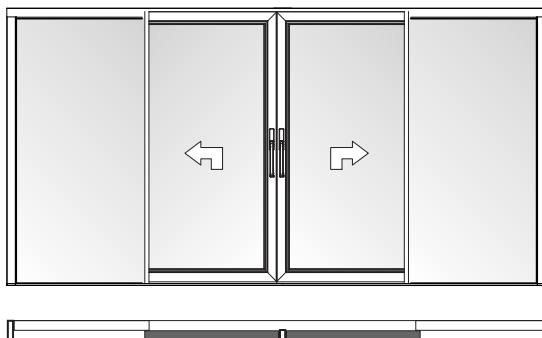

KIT AHM16.6730.XX

KIT Serratura	KIT Latch	AHM16.6730.2	Qt.
		Riscontro <i>Lock Striker</i>	2 pz.
		Serratura alzante <i>Latch for Lifting Sliding Window 2 Hooks</i>	2 pz.
		H Maniglia <i>H Handle</i>	400 mm.
		H Anta <i>H Sash</i>	735/1360 mm.
		L Rod L Asta	1300 mm.
		AHM16.6730.3	Qt.
		Scontro <i>Lock Striker</i>	3 pz.
		Serratura alzante <i>Latch for Lifting Sliding Window 2 Hooks</i>	2 pz.
		H Maniglia <i>H Handle</i>	1000 mm.
		H Anta <i>H Sash</i>	1260/1760 mm.
		L Rod L Asta	1700 mm.
		AHM16.6730.4	Qt.
		Riscontro <i>Lock Striker</i>	3 pz.
		Serratura alzante <i>Latch for Lifting Sliding Window 2 Hooks</i>	2 pz.
		H Maniglia <i>H Handle</i>	1000 mm.
		H Anta <i>H Sash</i>	1660/2160 mm.
	L Rod L Asta	2100 mm.	
	AHM16.6730.5	Qt.	
	Riscontro <i>Lock Striker</i>	3 pz.	
	Serratura alzante <i>Latch for Lifting Sliding Window 2 Hooks</i>	2 pz.	
	H Maniglia <i>H Handle</i>	1000 mm.	
	H Anta <i>H Sash</i>	1060/2560 mm.	
	L Rod L Asta	2500 mm.	
	AHM16.6730.6	Qt.	
	Riscontro <i>Lock Striker</i>	3 pz.	
	Serratura alzante <i>Latch for Lifting Sliding Window 2 Hooks</i>	2 pz.	
	H Maniglia <i>H Handle</i>	1000 mm.	
	H Anta <i>H Sash</i>	2460/2860 mm.	
	L Rod L Asta	2800 mm.	
	AHM16.6730.7	Qt.	
	Riscontro <i>Lock Striker</i>	3 pz.	
	Serratura alzante <i>Latch for Lifting Sliding Window 2 Hooks</i>	2 pz.	
	H Maniglia <i>H Handle</i>	1000 mm.	
	H Anta <i>H Sash</i>	2860/3360 mm.	
	L Rod L Asta	3300 mm.	
	AHM16.6730.8	Qt.	
	Riscontro <i>Lock Striker</i>	3 pz.	
	Serratura alzante <i>Latch for Lifting Sliding Window 2 Hooks</i>	2 pz.	
	H Maniglia <i>H Handle</i>	1000 mm.	
	H Anta <i>H Sash</i>	3260/3860 mm.	
	L Rod L Asta	3800 mm.	
	AHM16.6734.1		
	*Riscontro singolo extra <i>*Adjustable Lock Striker extra</i>		

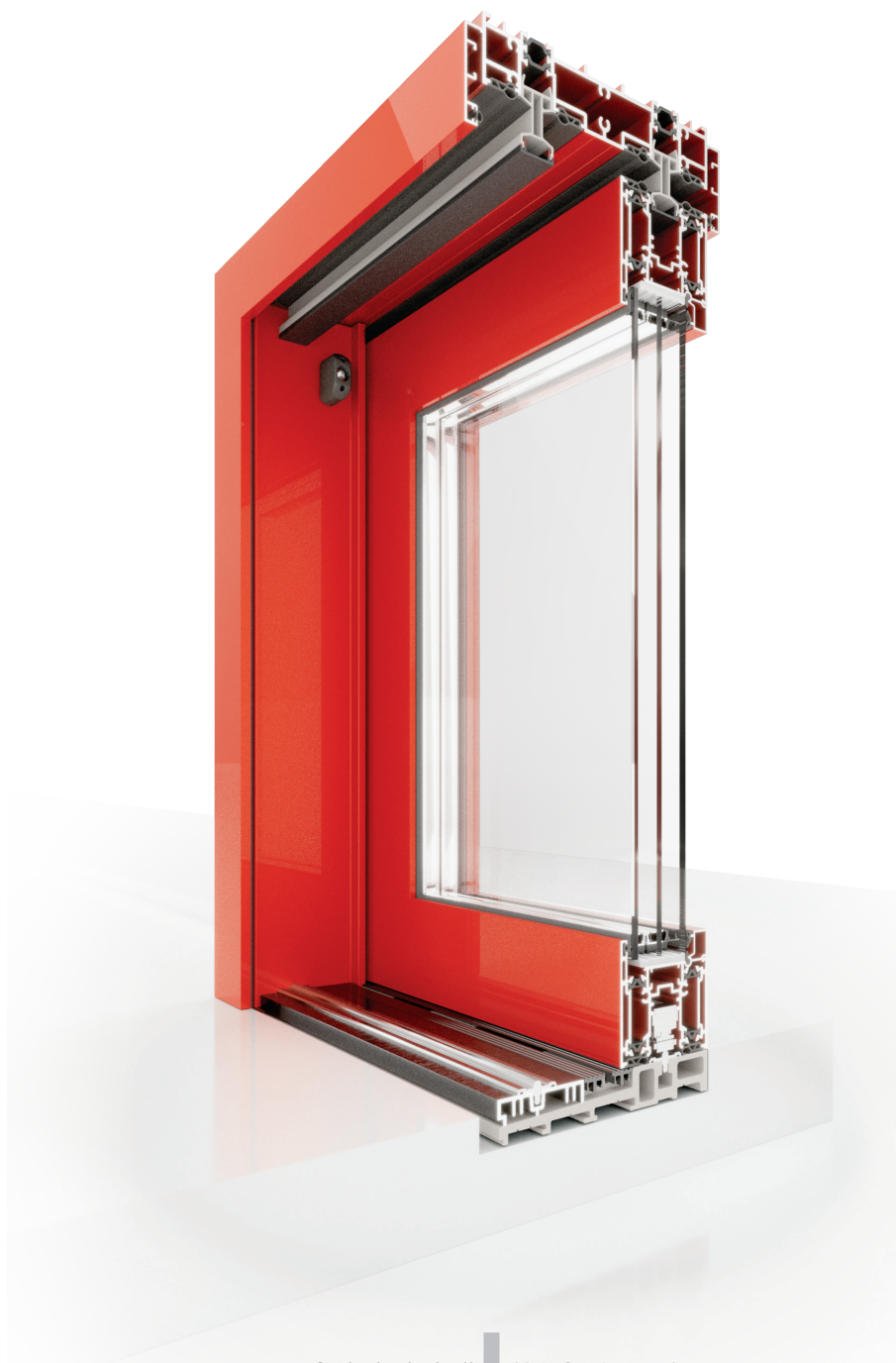

Nodi
Main Sections

Gruppo D

Sezioni principali
e Accessori
Sc. 1:1

*Main Sections and
Accessories
Scale 1:1*



Anta mobile Incassata
Casket Door

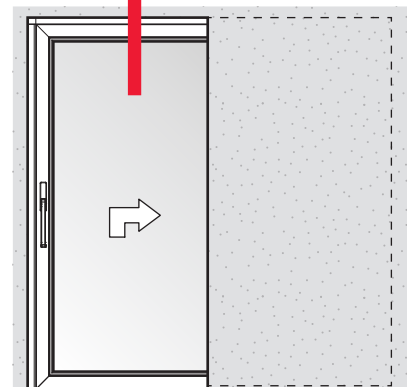

Anta 45°
45° Sash

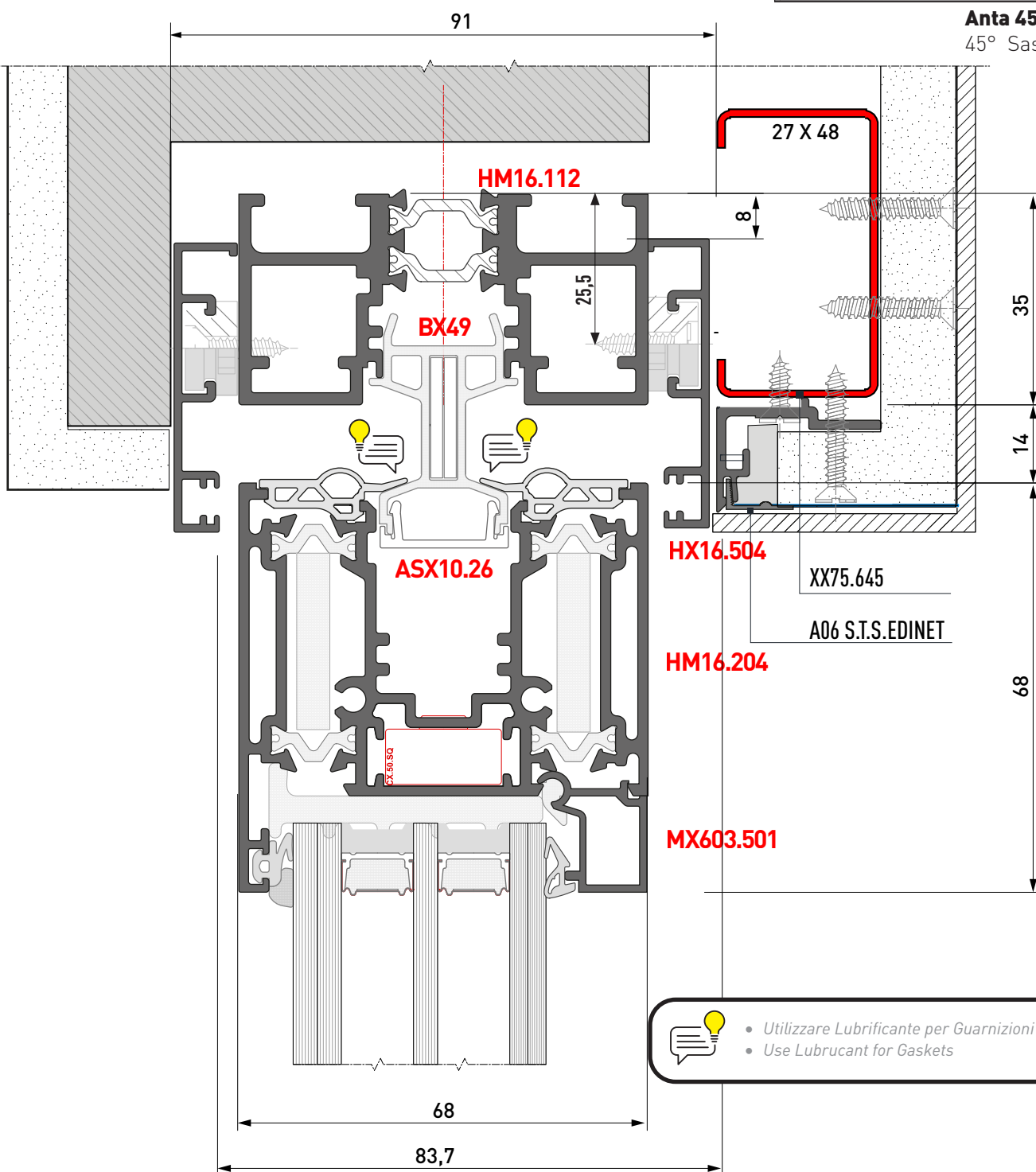

• Utilizzare Lubrificante per Guarnizioni
• Use Lubricant for Gaskets



Anta mobile Incassata
Casket Door

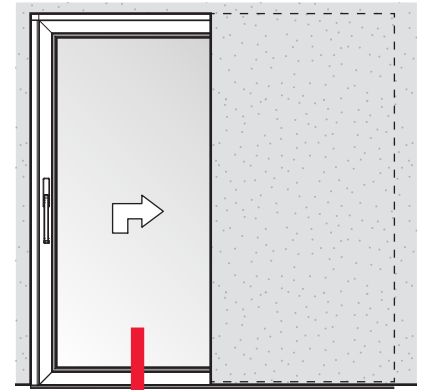

Anta 45°
45° Sash

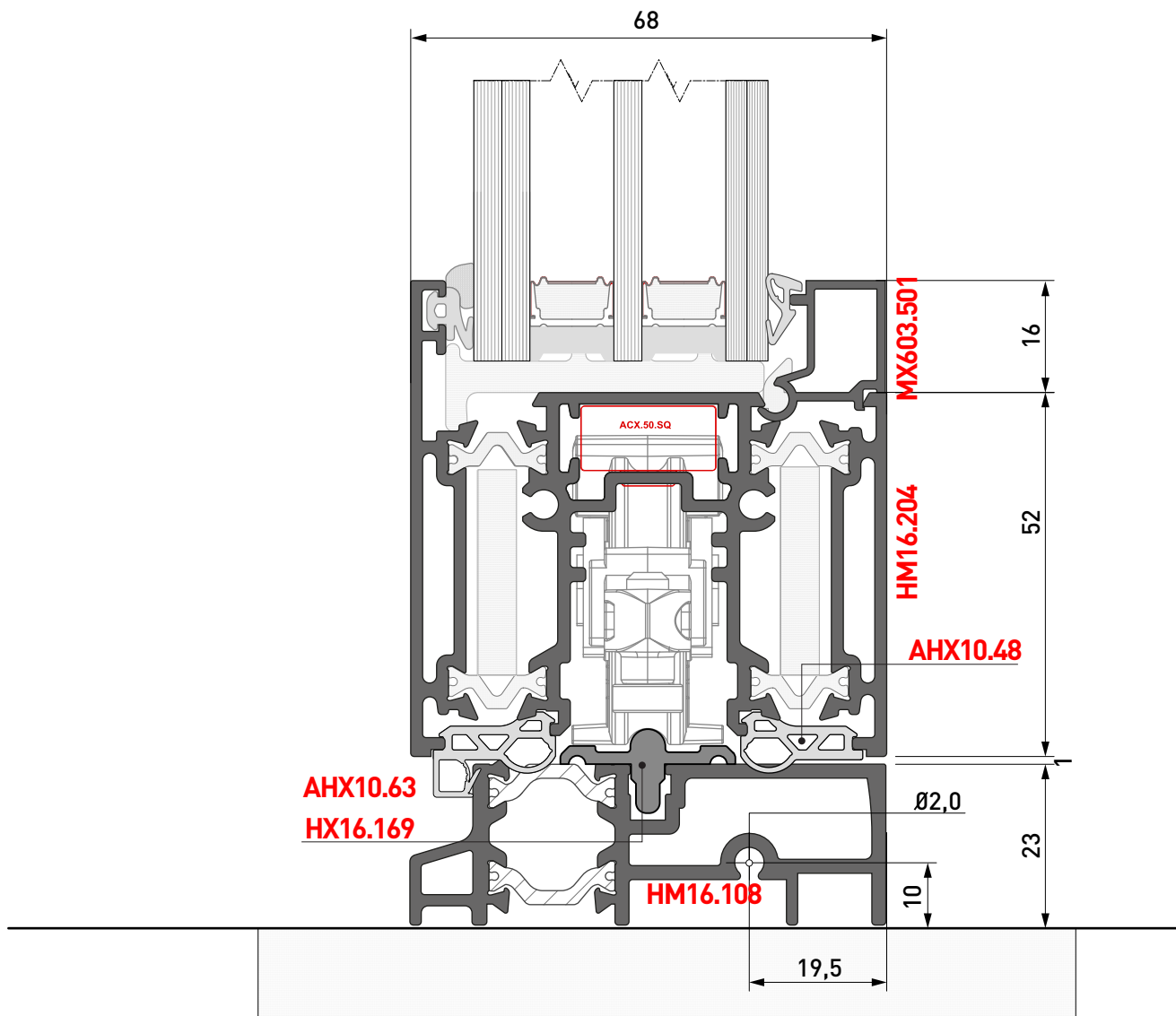



Anta mobile Incassata
Casket Door

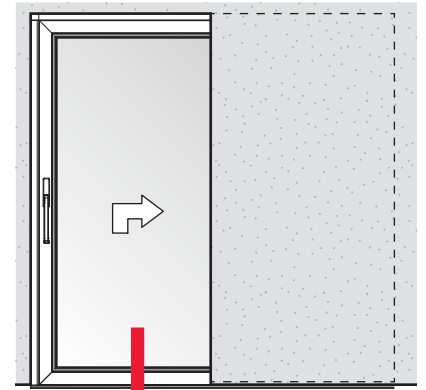

Anta 45°
45° Sash

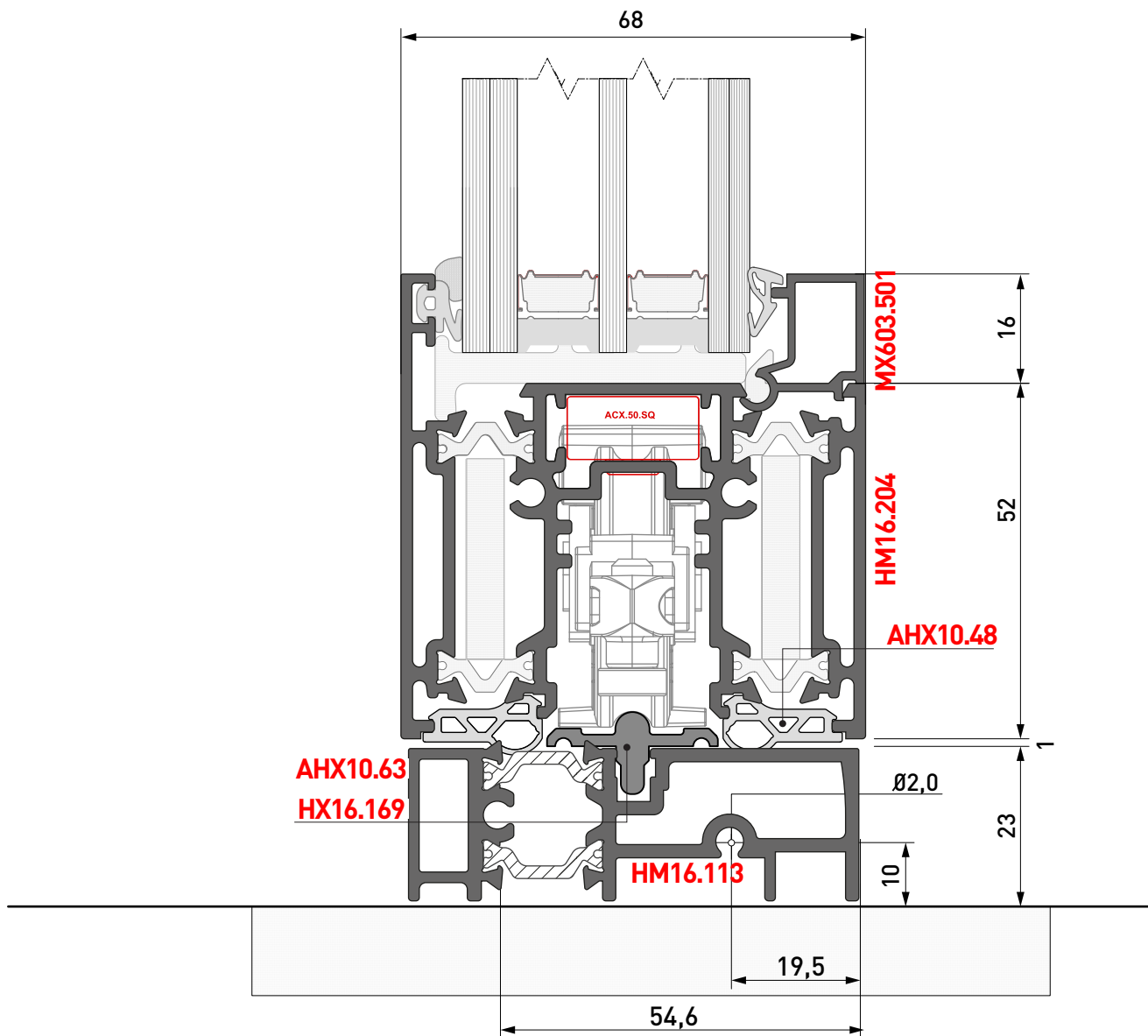



Anta mobile Incassata
Casket Door

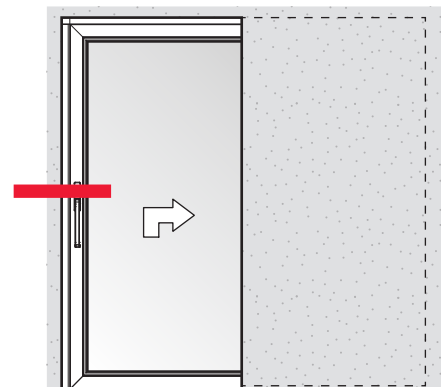

Anta 45°
45° Sash

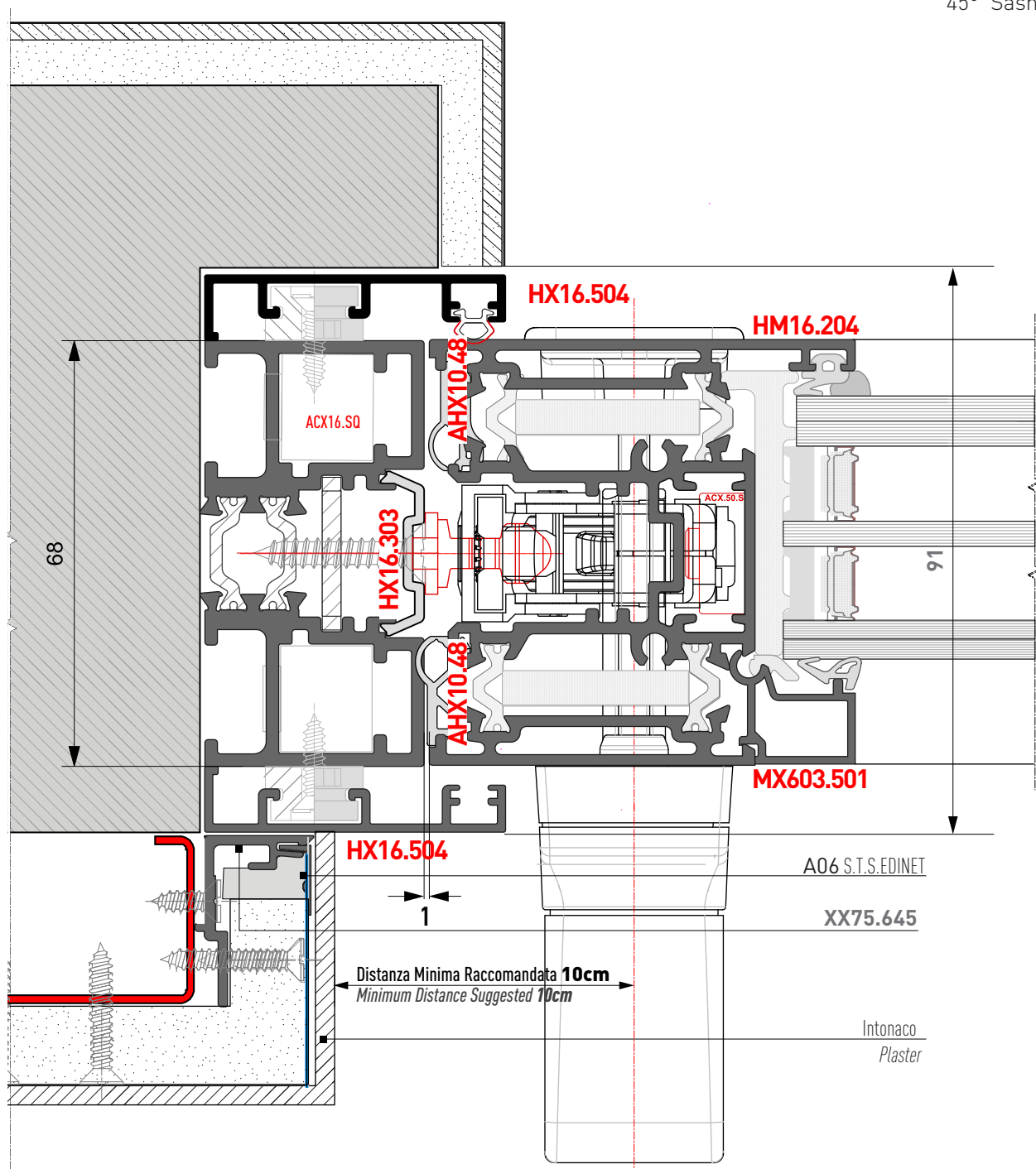



Anta mobile Incassata
Casket Door

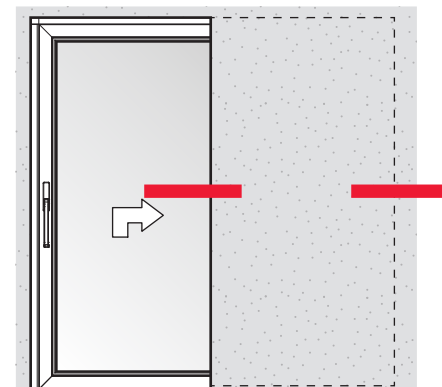

Anta 45°
45° Sash

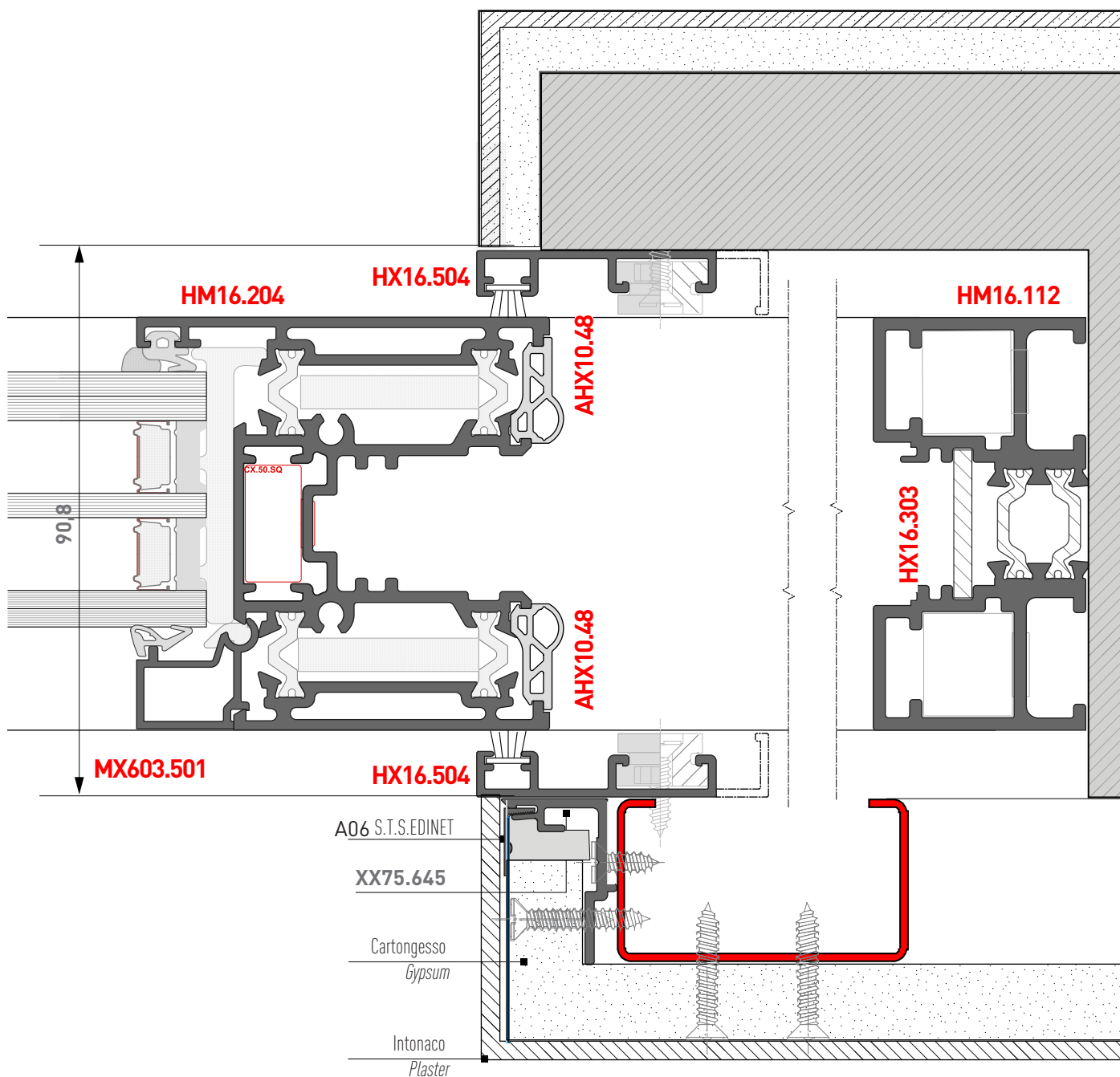



Doppia Anta 45° mobile Incassata
Casket Double 45° Door

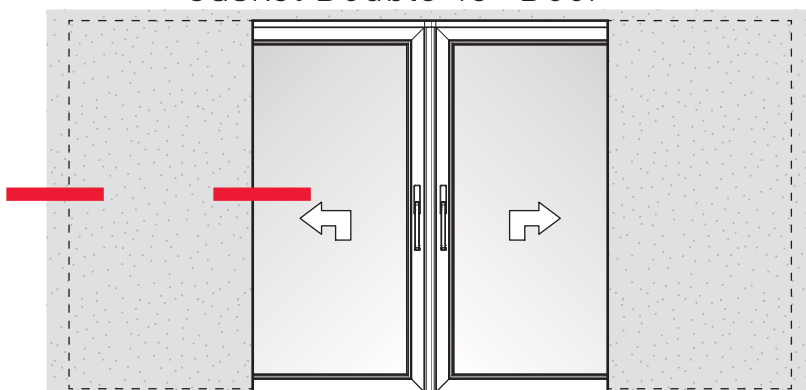
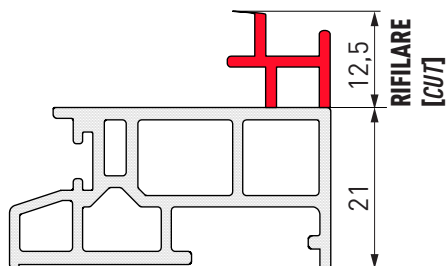

Anta 45°
Sash 45°

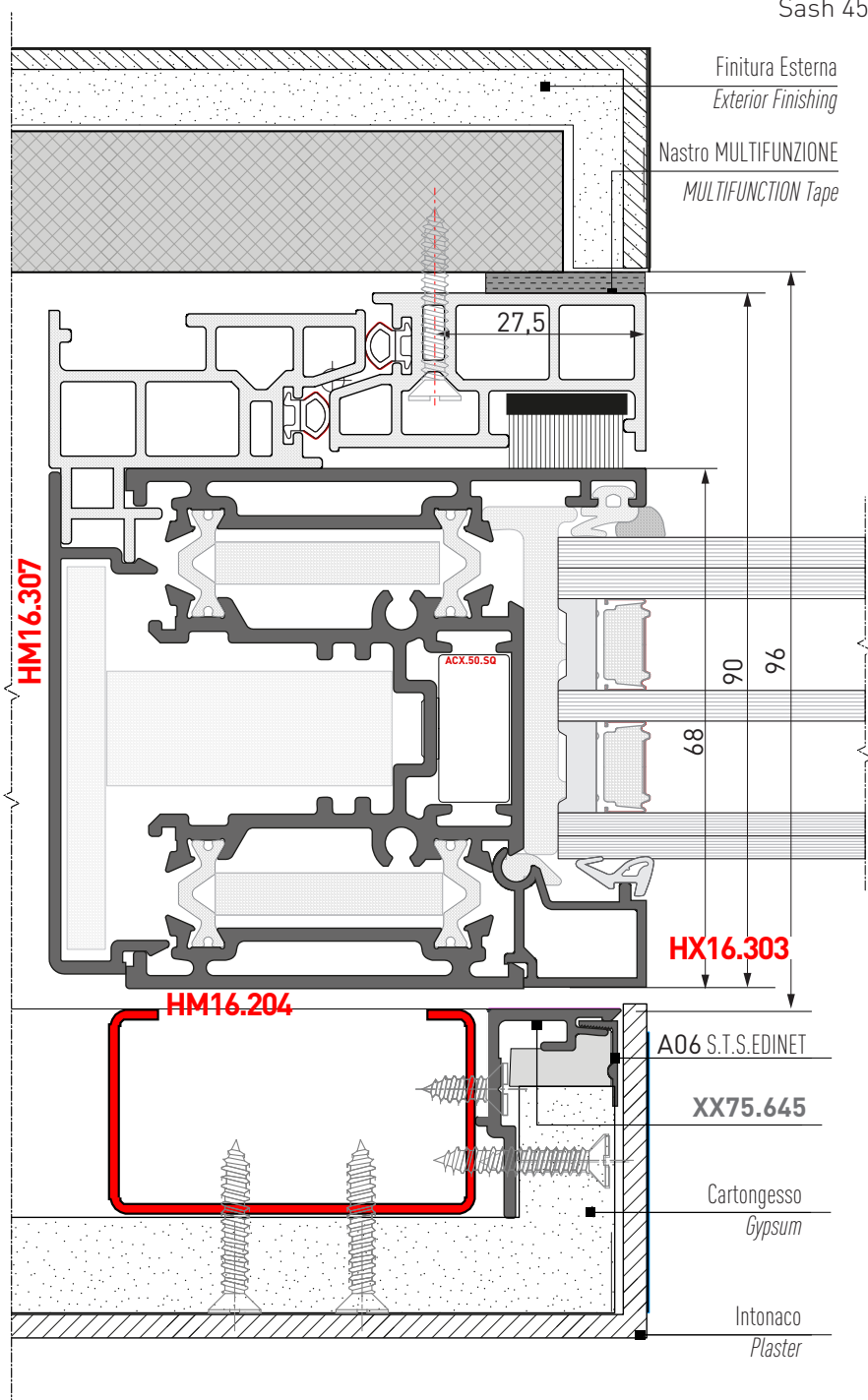
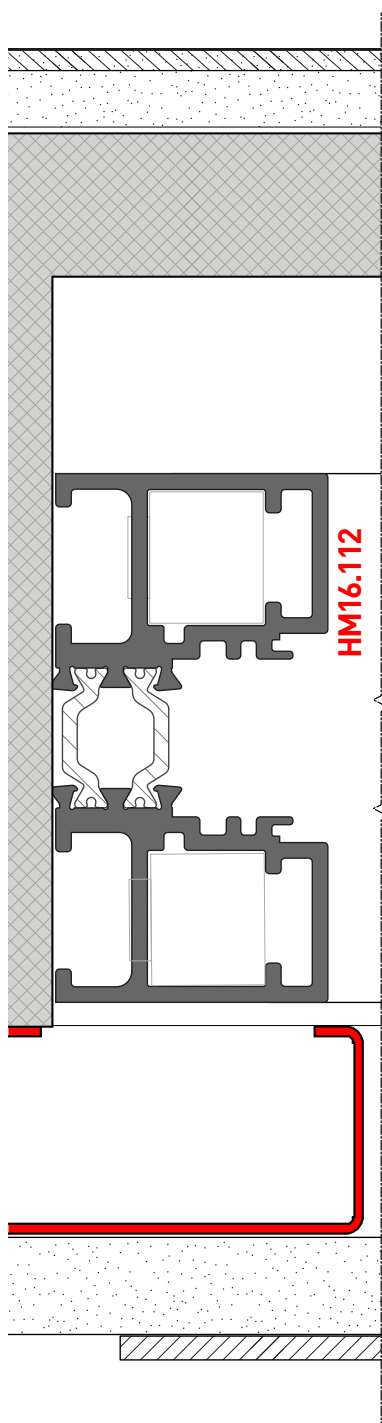



Doppia Anta 90° mobile Incassata
Casket Double Minimal Door

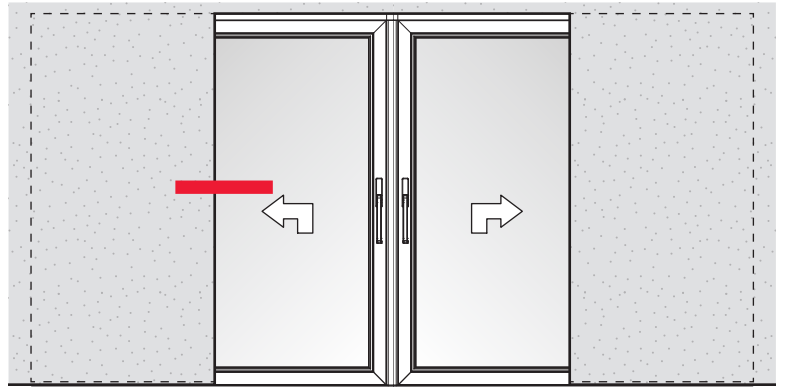

Anta90°
90° Sash

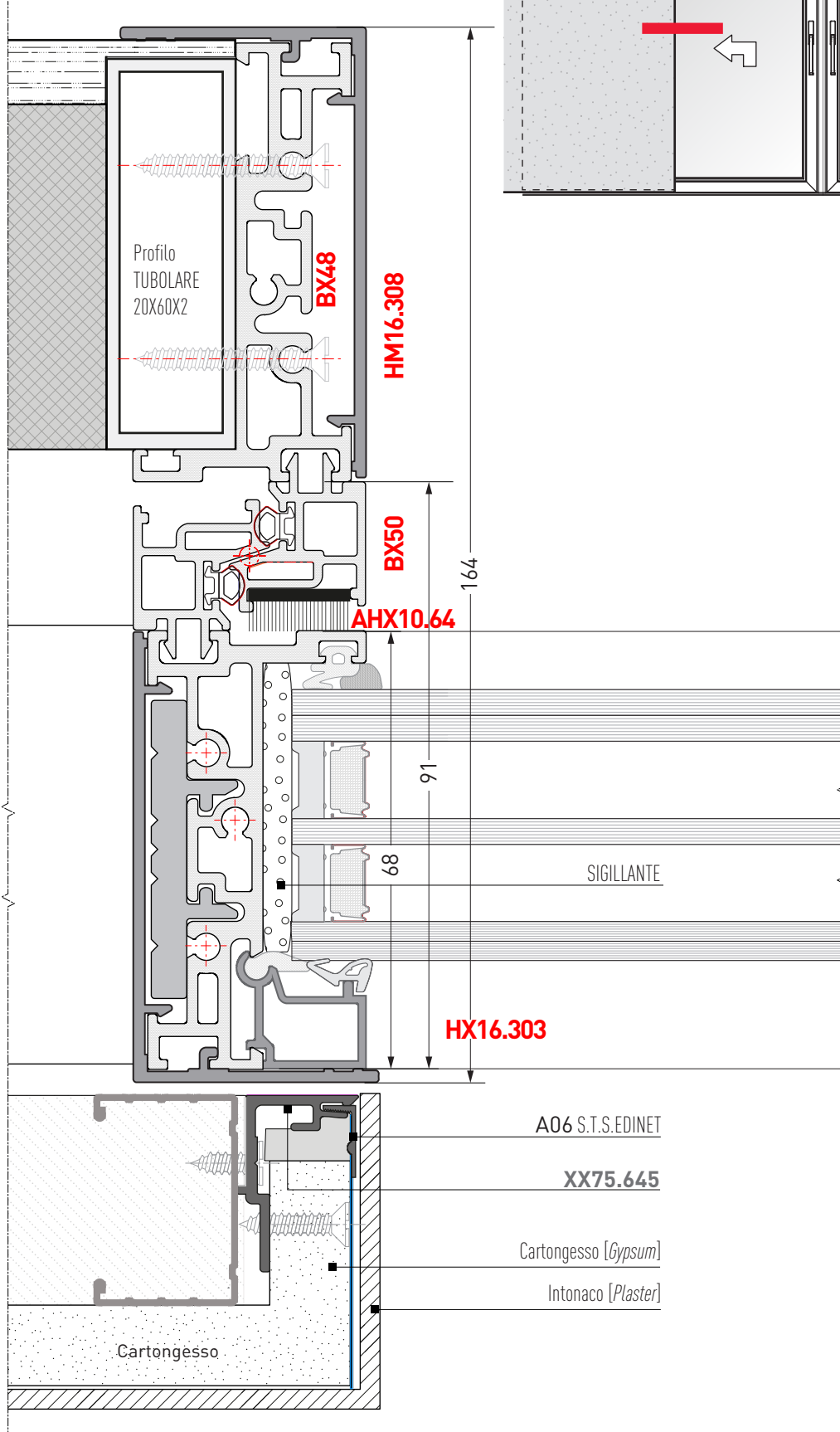

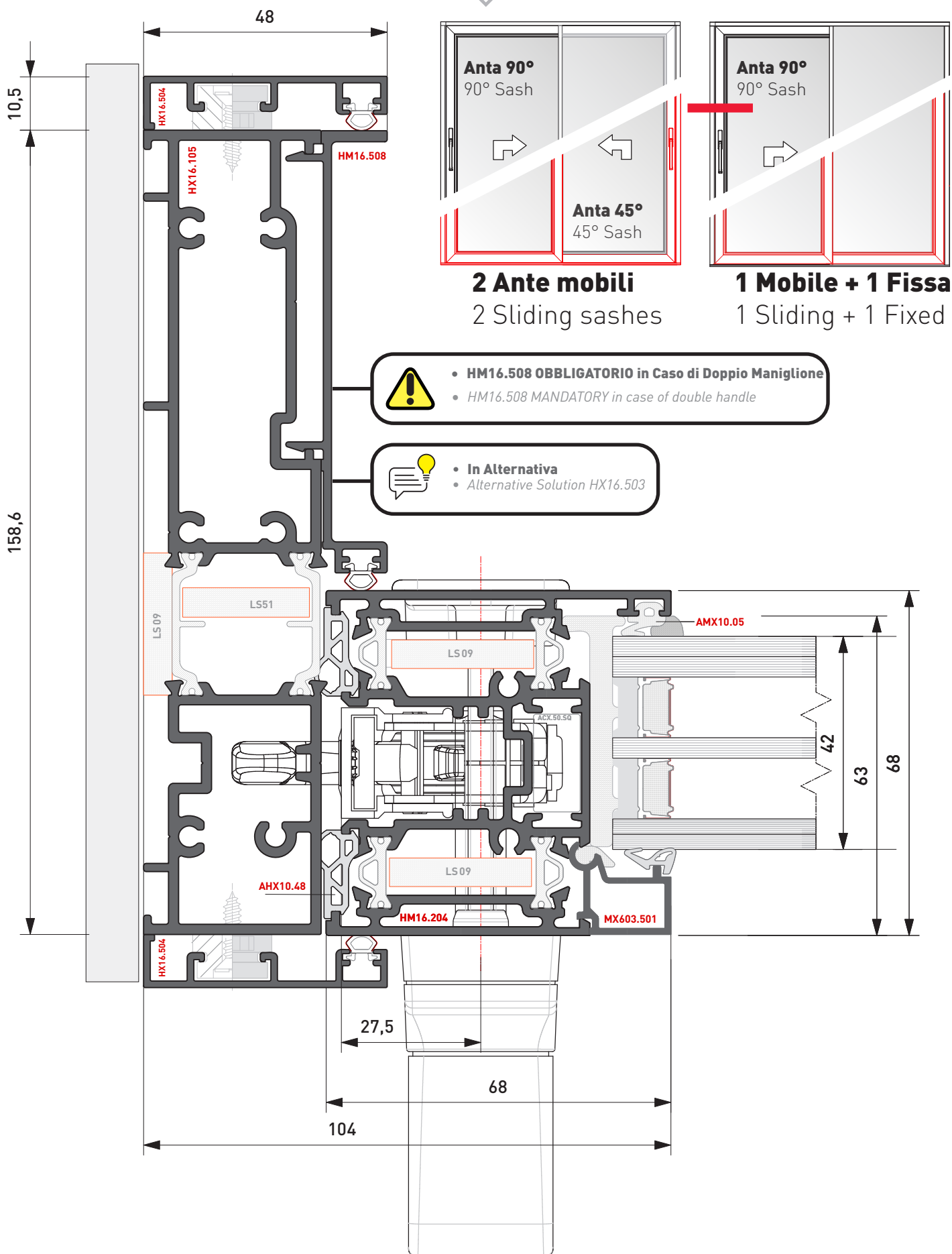



Anta mobile con Vetrata Fissa
Movable sash with Glazing Wall

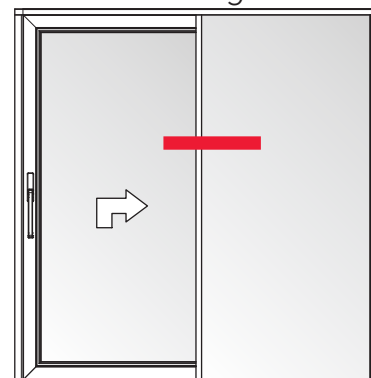
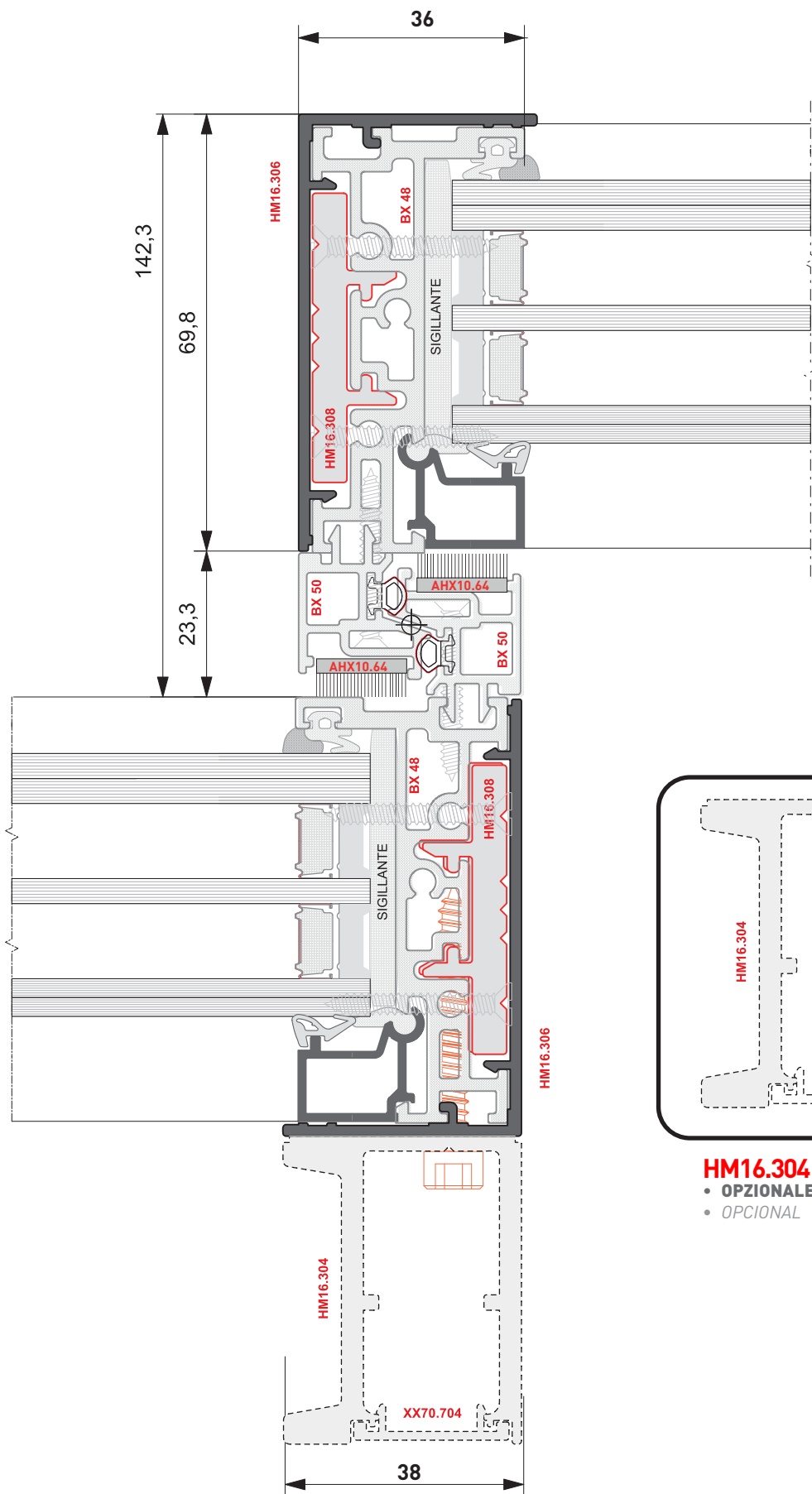

Anta 90°
90° Sash

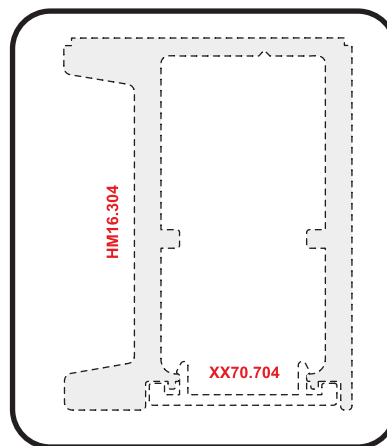

HM16.304 + XX70.704

- OPZIONALE
- OPCIONAL



Anta mobile con Vetrata Fissa
Movable sash with Glazing Wall

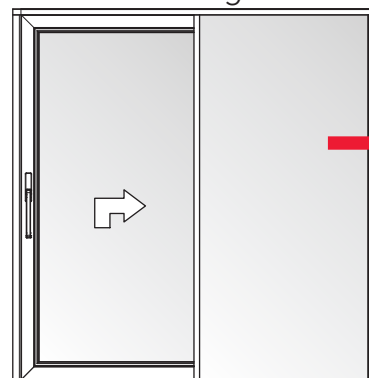

Anta 90°
90° Sash

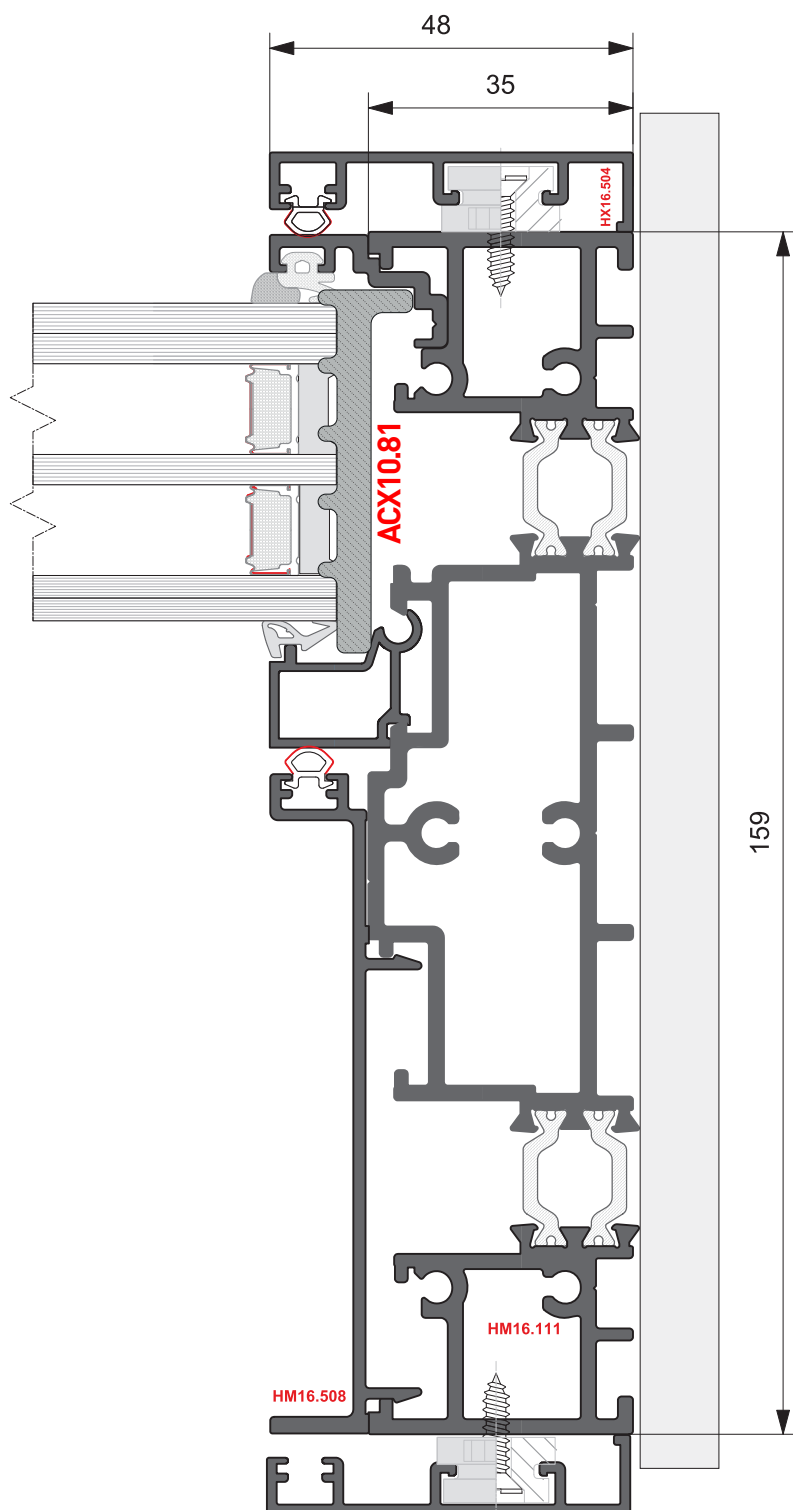



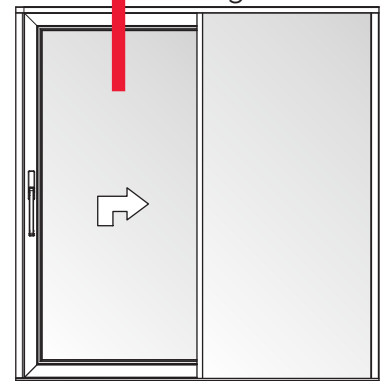

Anta mobile con Vetrata Fissa
Movable sash with Glazing Wall

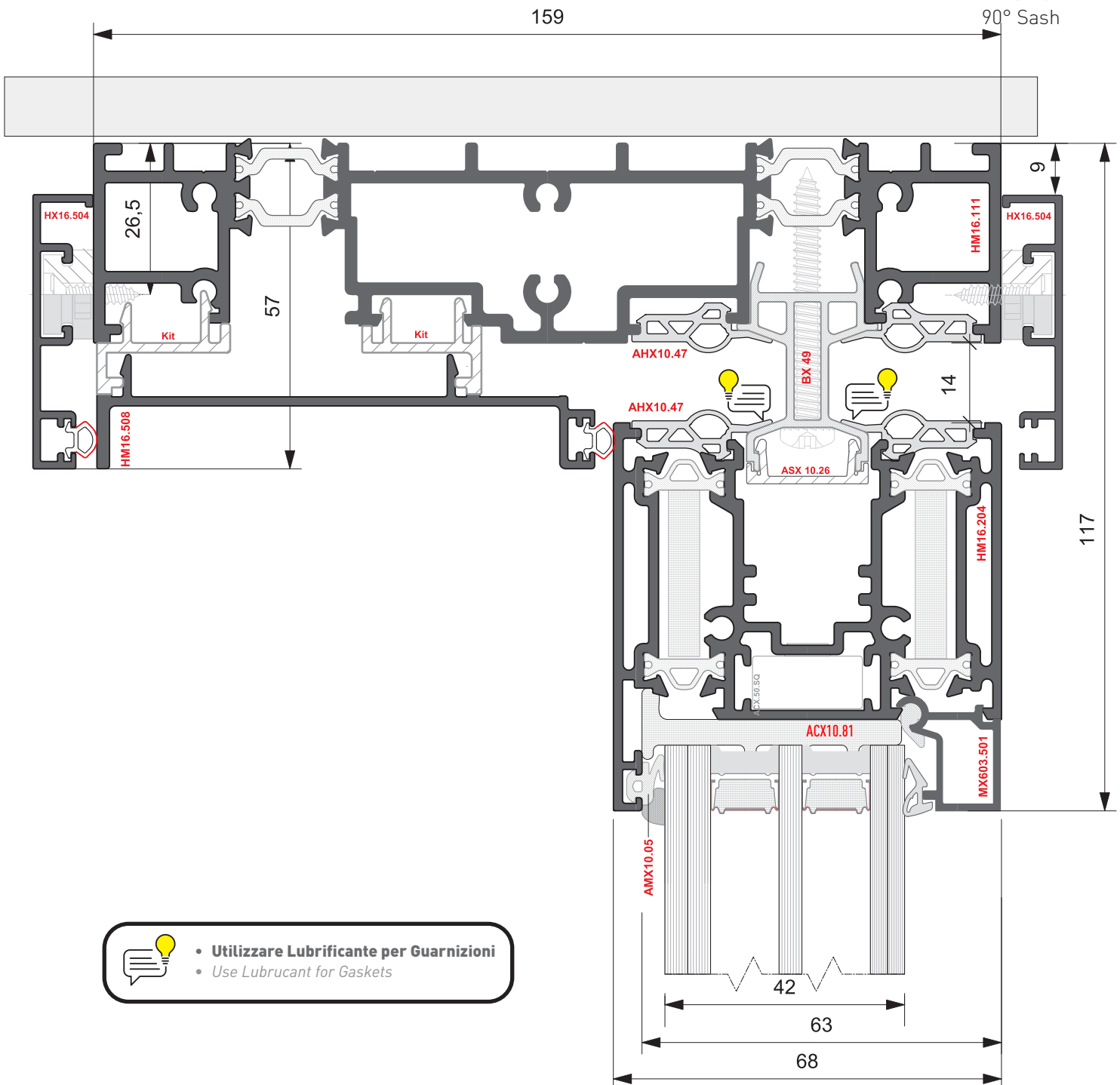

Anta 90°
90° Sash





- Utilizzare Lubrificante per Guarnizioni
- Use Lubricant for Gaskets



Anta mobile con Vetrata Fissa
Movable sash with Glazing Wall

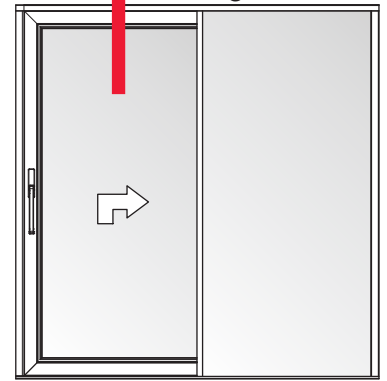

Anta 90°
90° Sash

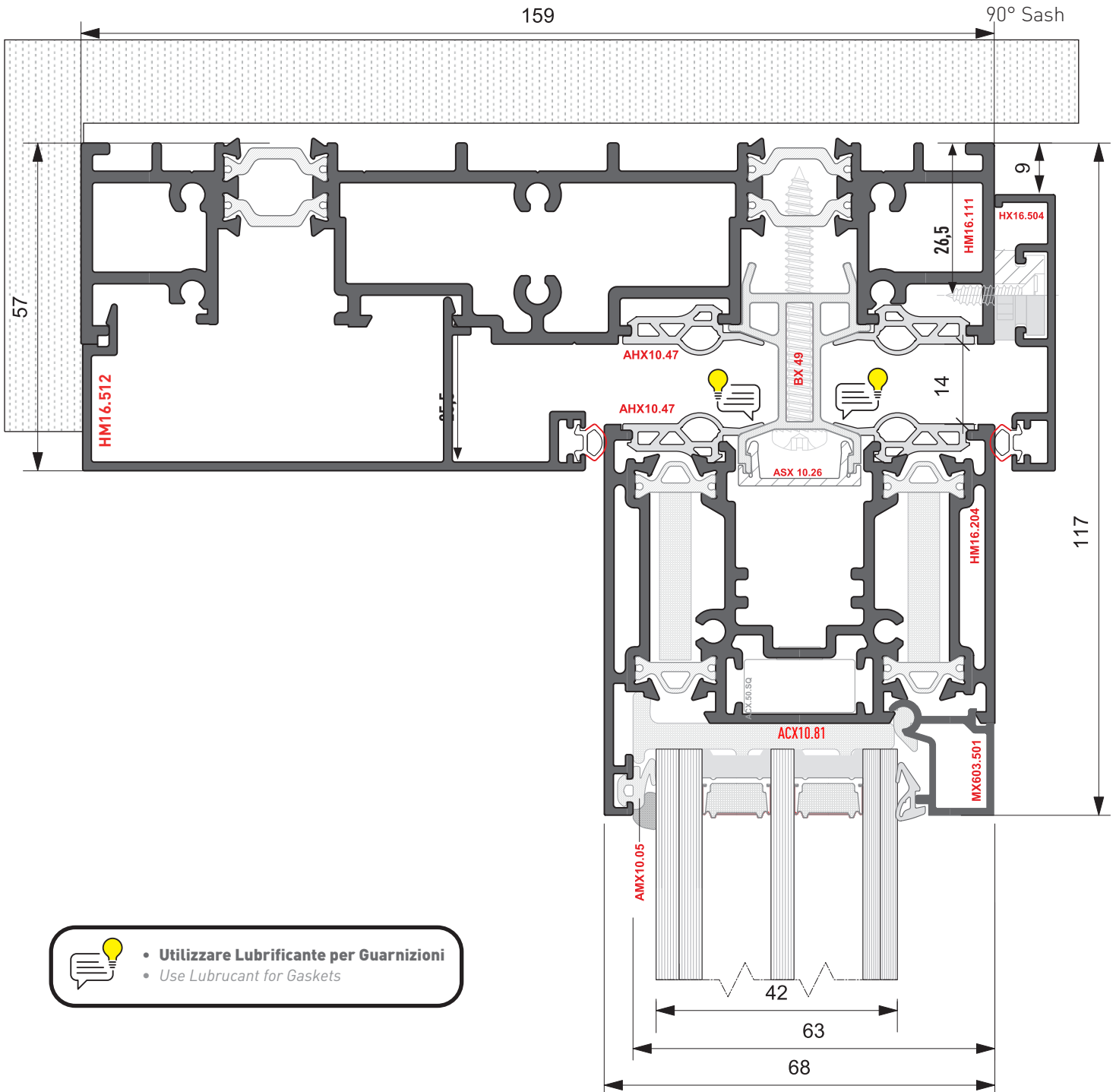



- **Utilizzare Lubrificante per Guarnizioni**
- *Use Lubricant for Gaskets*



Anta mobile con Vetrata Fissa
Movable sash with Glazing Wall

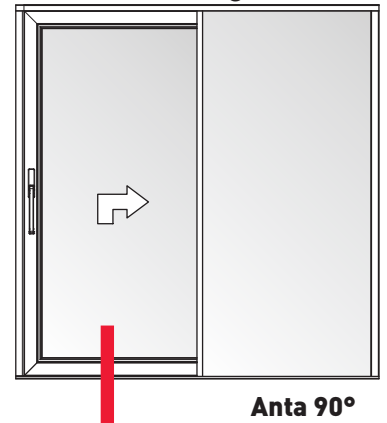

Anta 90°
90° Sash

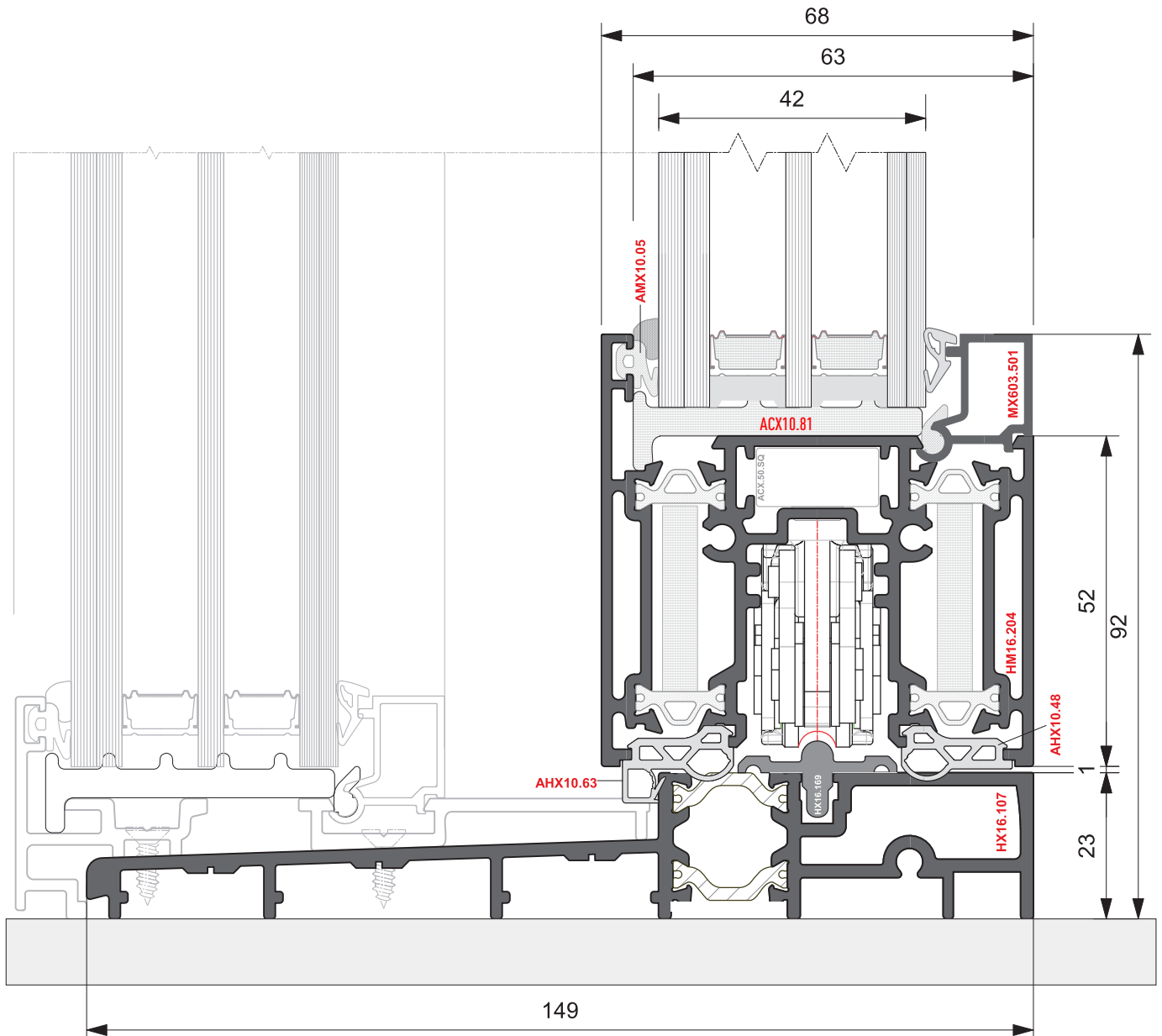



Anta mobile con Vetrata Fissa
Movable sash with Glazing Wall

Variante soglia BX52
BX52Threshold variant

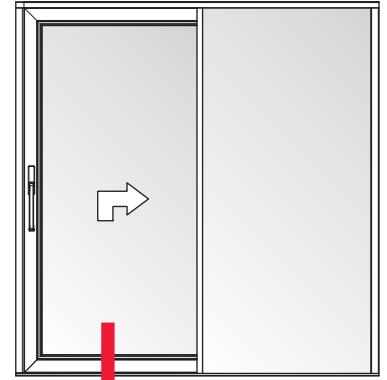

Anta 90°
90° Sash

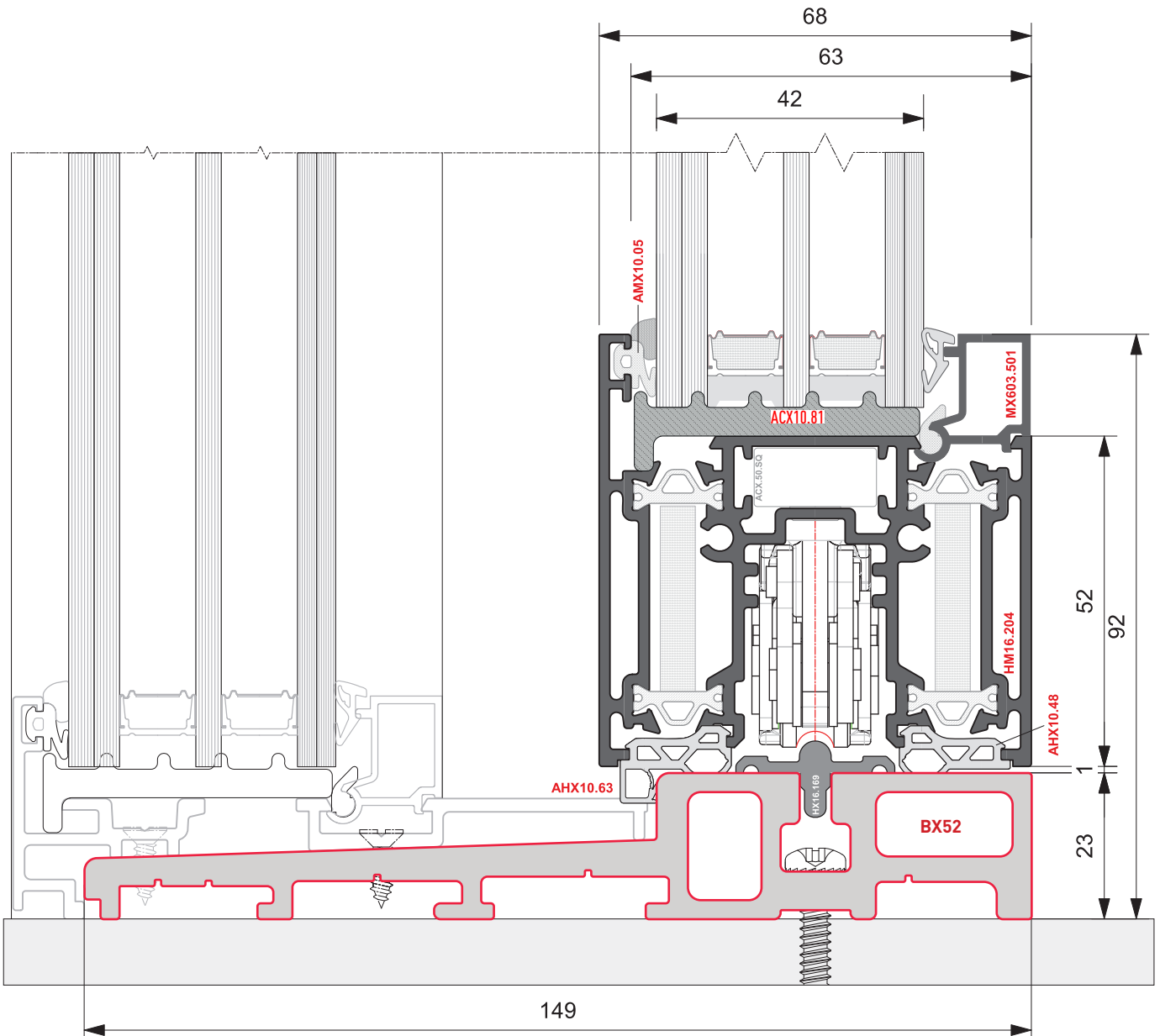



Anta mobile con Vetrata Fissa
Movable sash with Glazing Wall

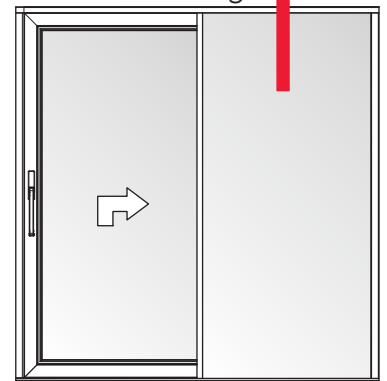

Anta 90°
90° Sash

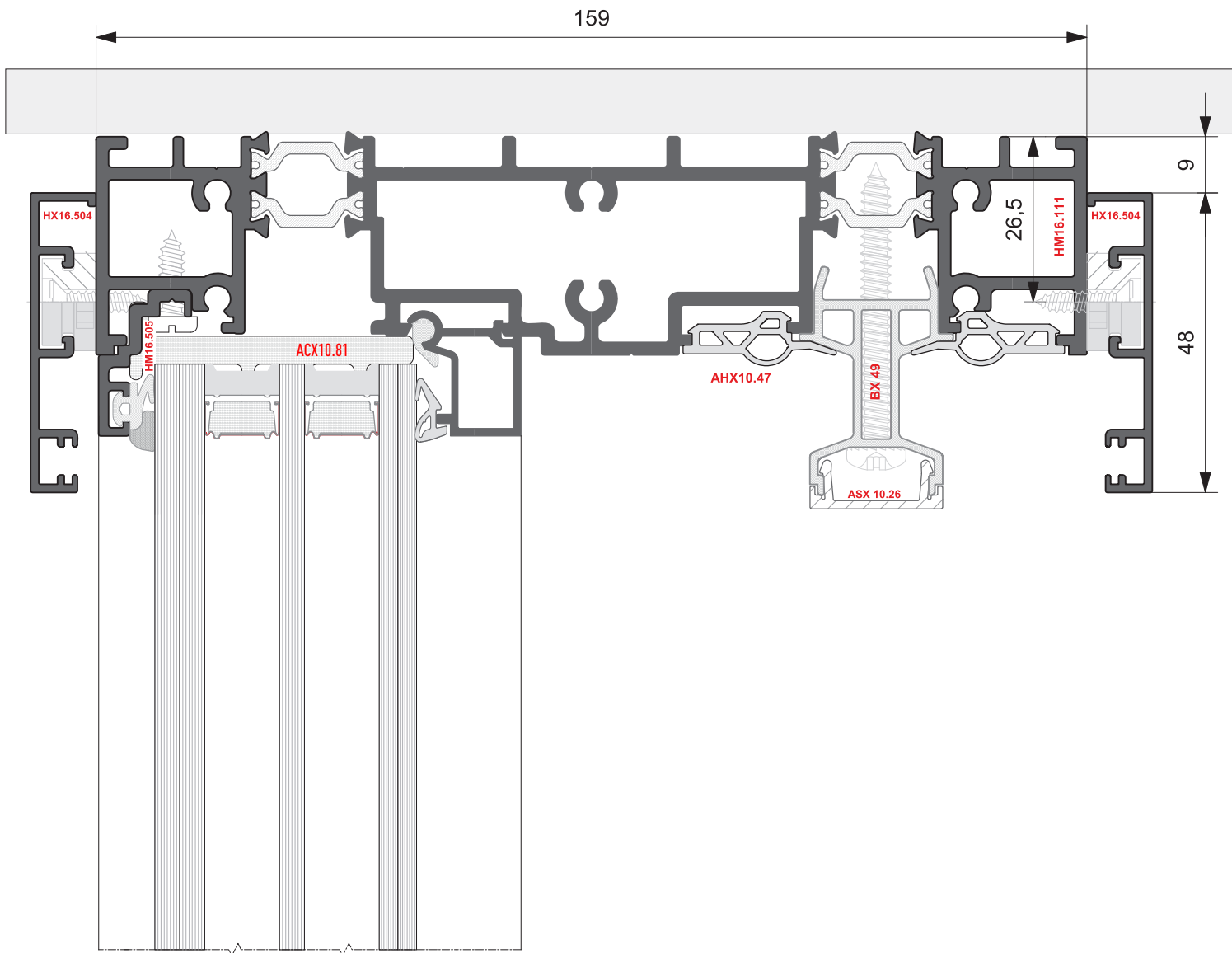



Anta mobile con Vetrata Fissa
Movable sash with Glazing Wall

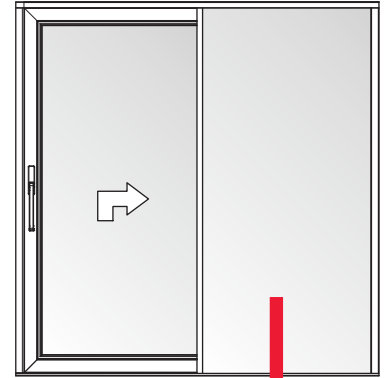

Anta 90°
90° Sash

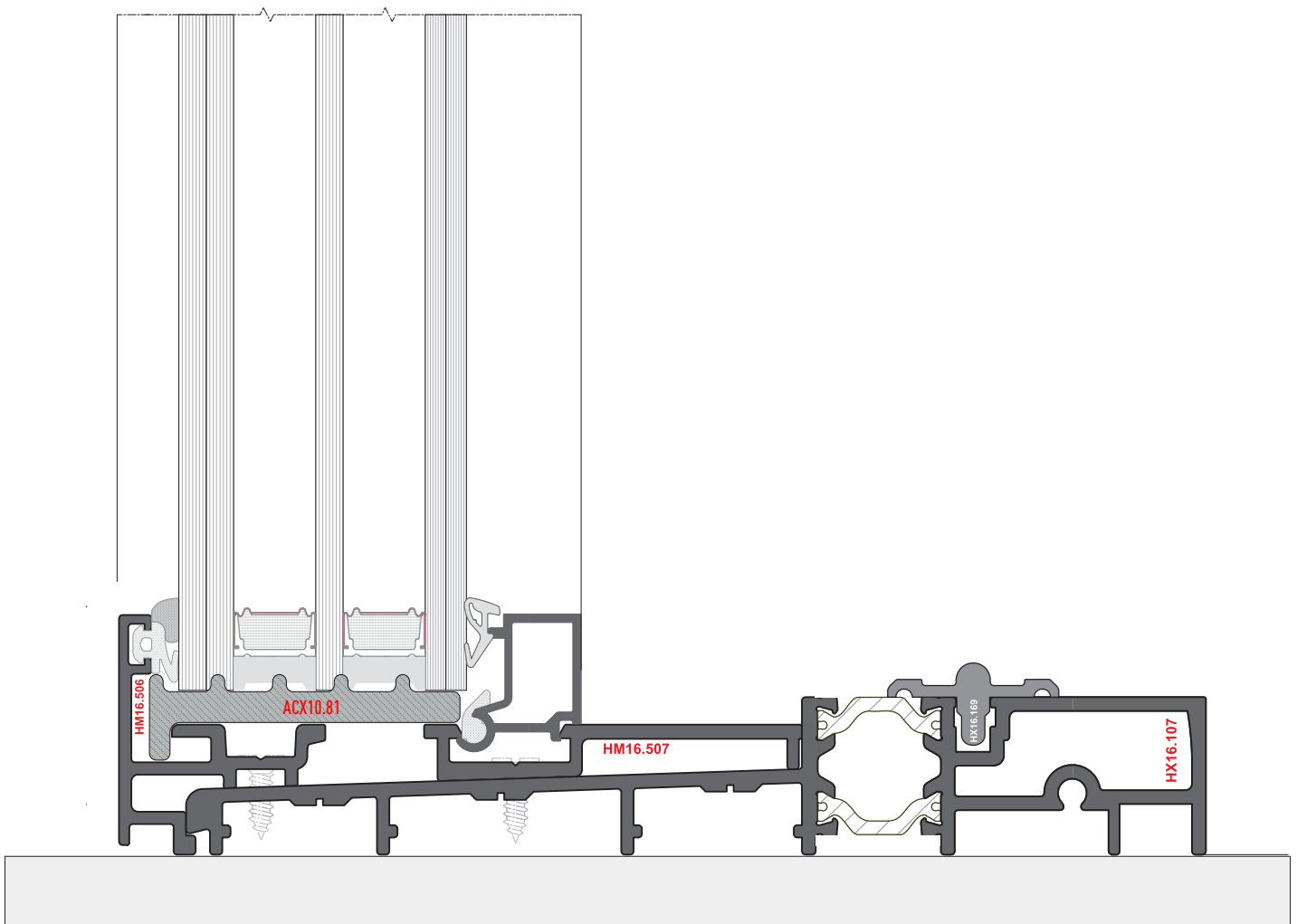



2 Ante mobili
2 Movable sashes

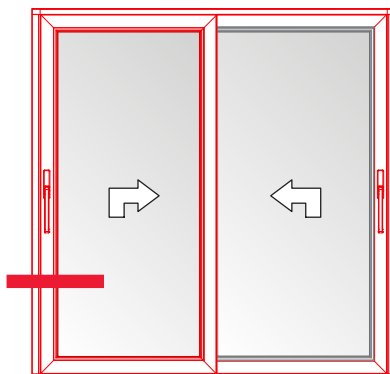

Anta 45°
45° Sash

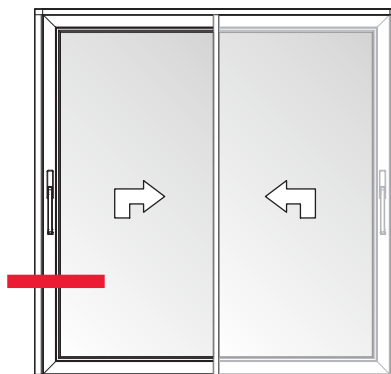

Anta 90°
90° Sash

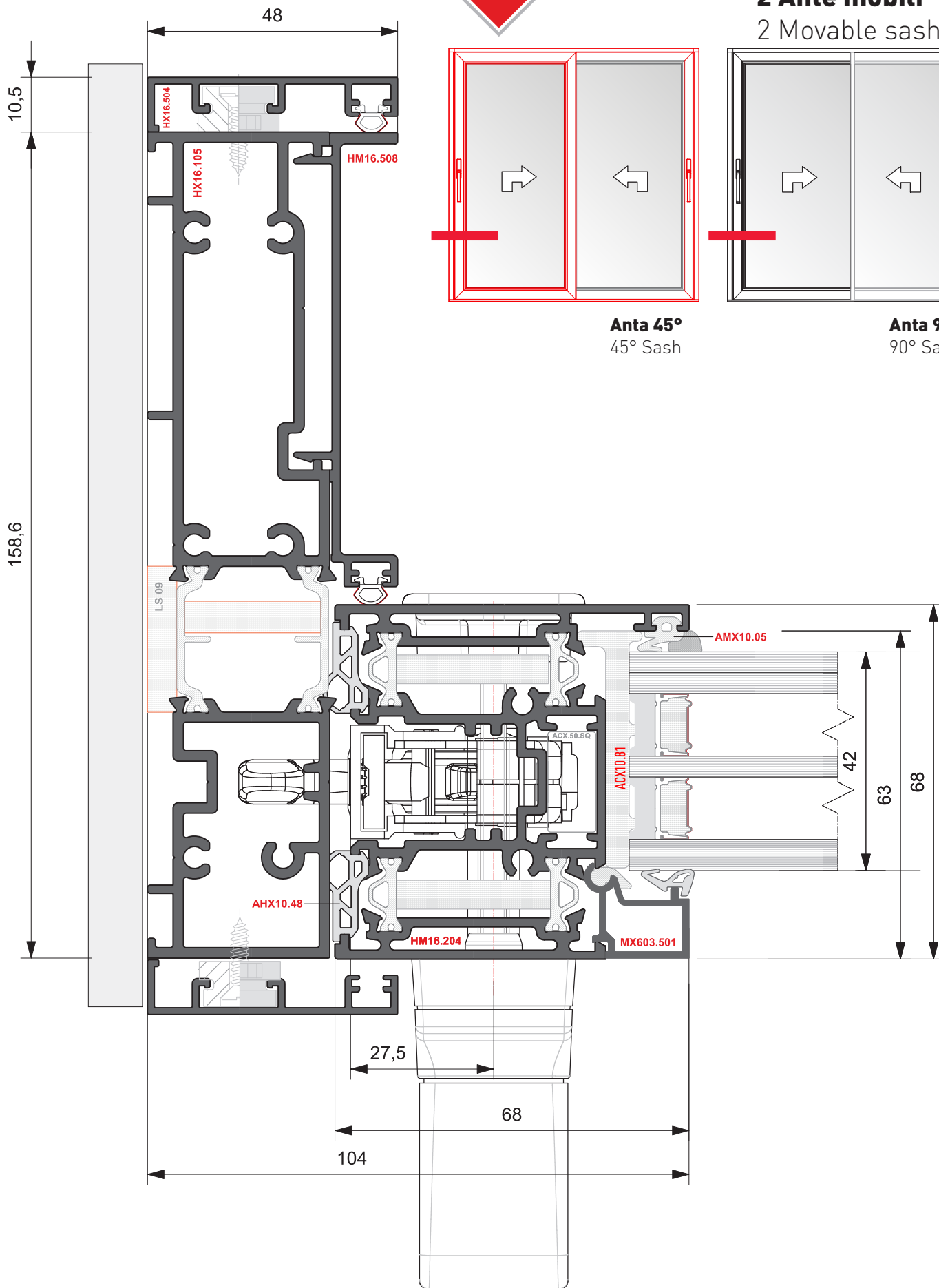

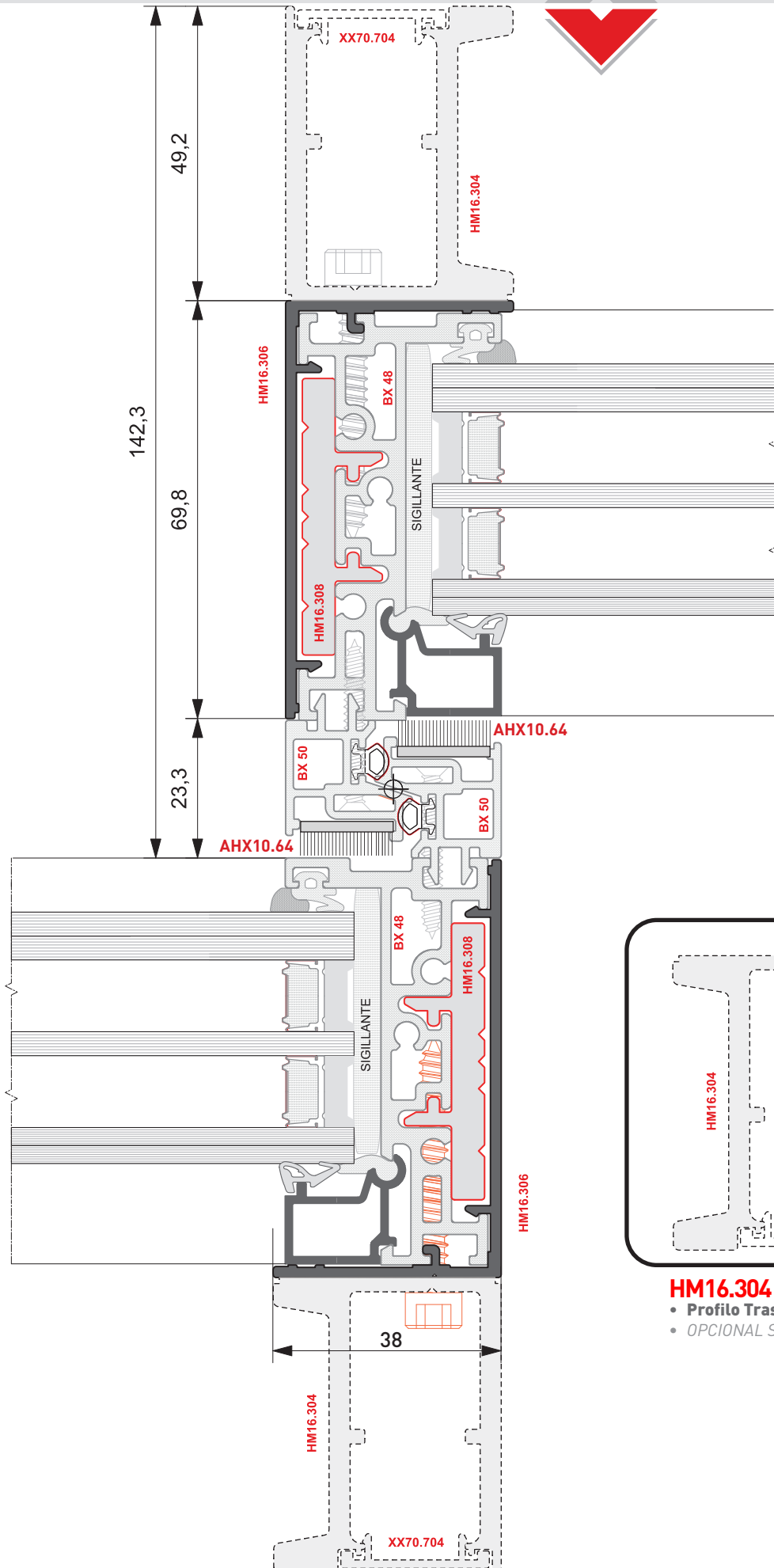

2 Ante mobili
2 Movable sashes

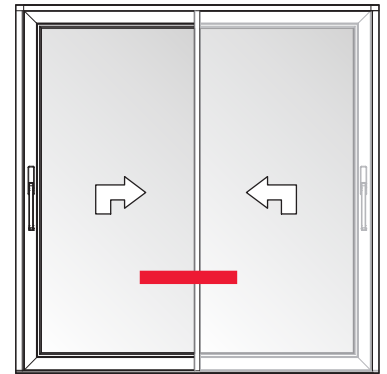

Anta 90°
90° Sash

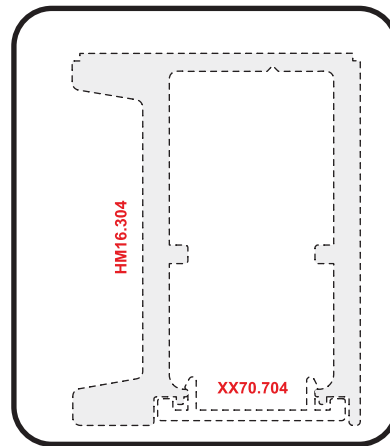

HM16.304 + XX70.704
• Profilo Trascinavetro **OPZIONALE**
• *OPCIONAL* Sash Handle



2 Ante mobili
2 Movable sashes

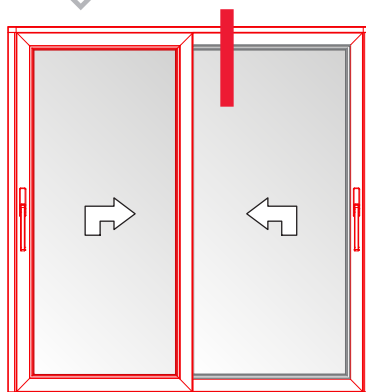

Anta 45°
45° Sash

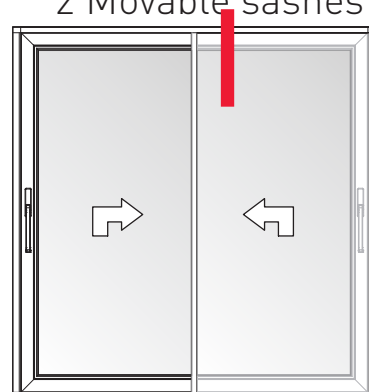

Anta 90°
90° Sash

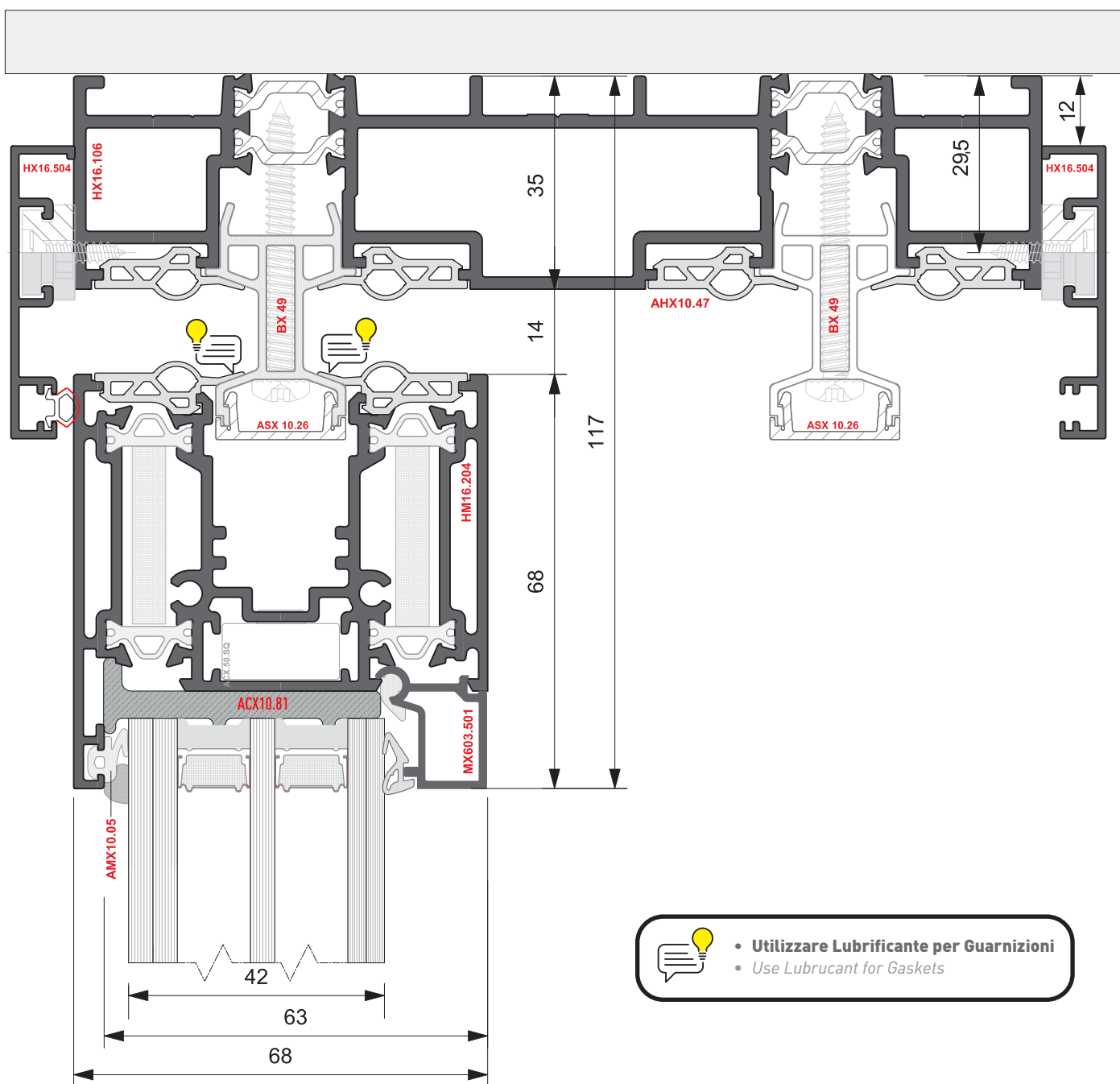

 • **Utilizzare Lubrificante per Guarnizioni**
• Use Lubricant for Gaskets



2 Ante mobili
2 Movable sashes

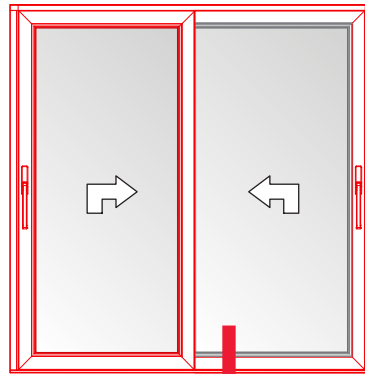

Anta 45°
45° Sash

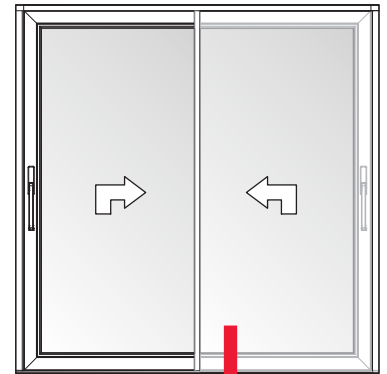

Anta 90°
90° Sash

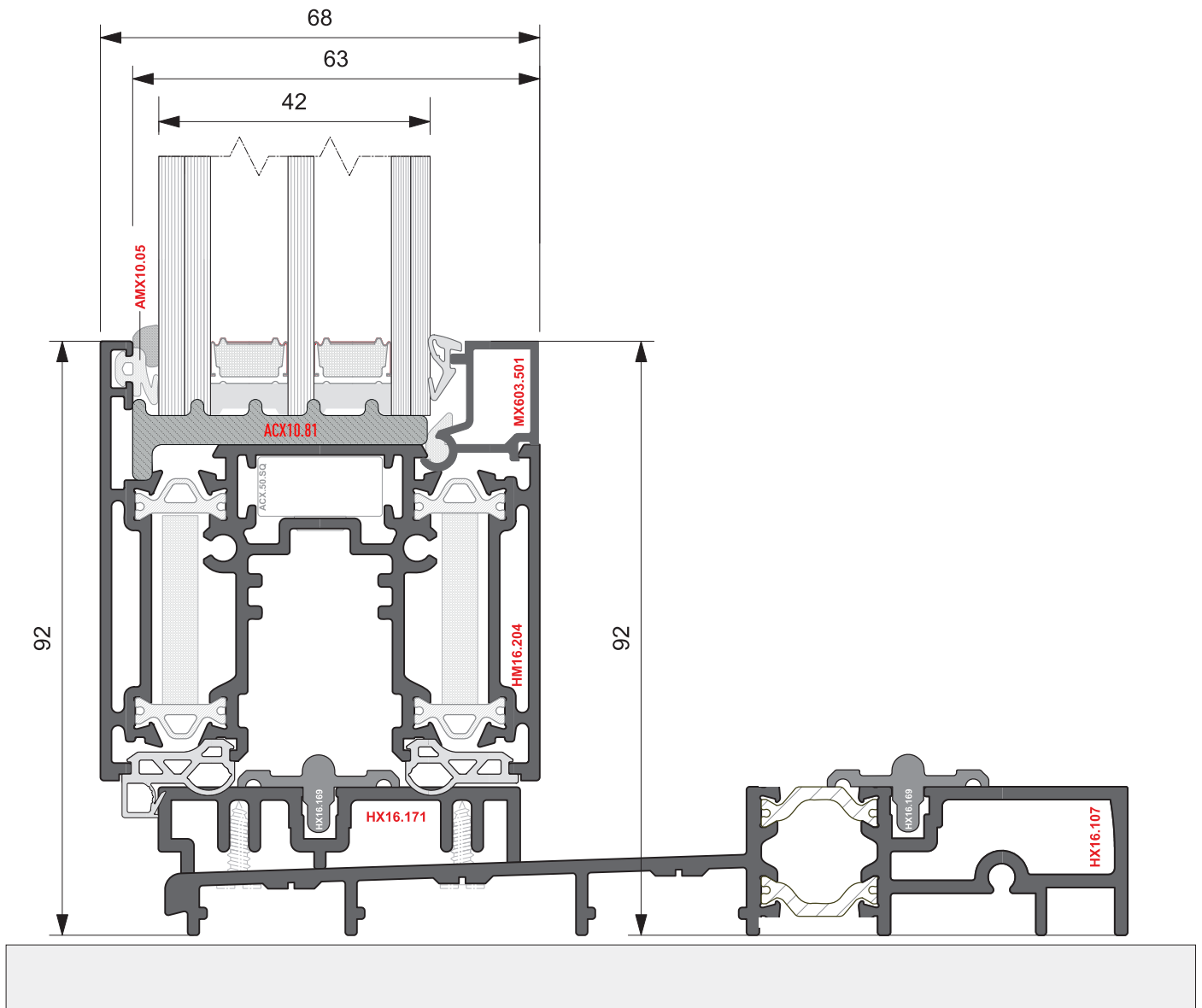



2 Ante mobili

2 Movable sashes

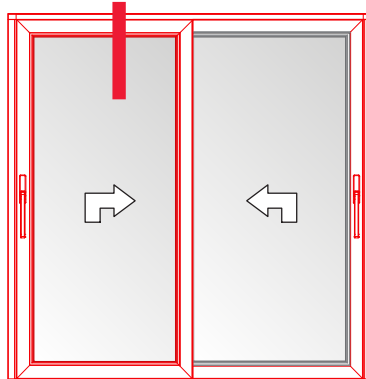

Anta 45°
45° Sash

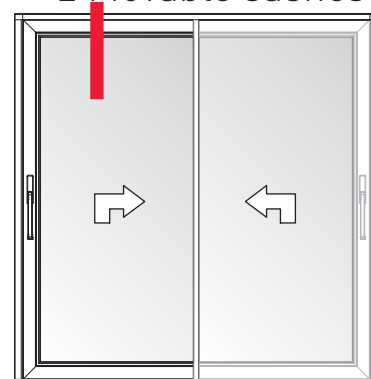

Anta 90°
90° Sash

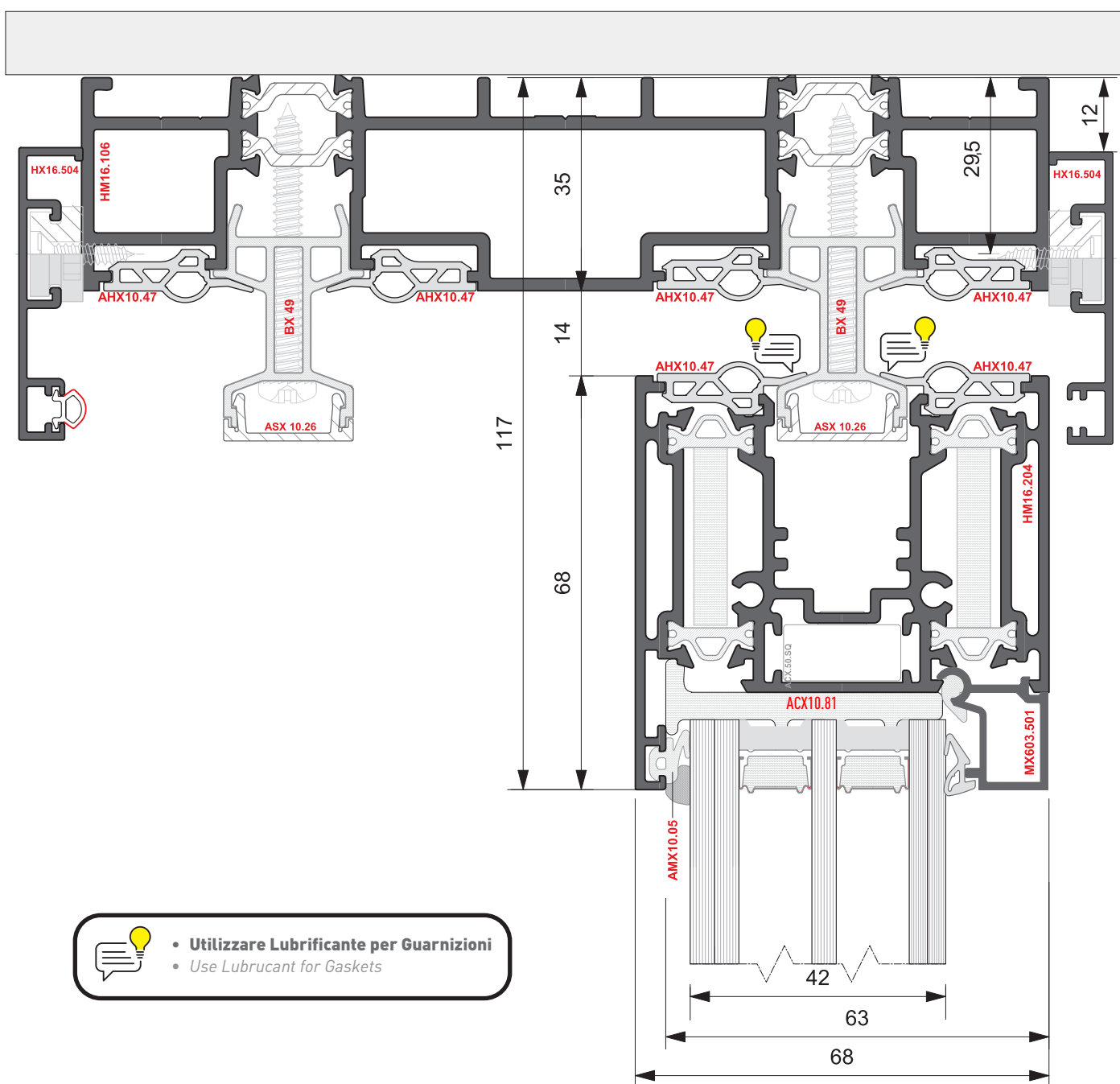

 • **Utilizzare Lubrificante per Guarnizioni**
• Use Lubricant for Gaskets



2 Ante mobili
2 Movable sashes

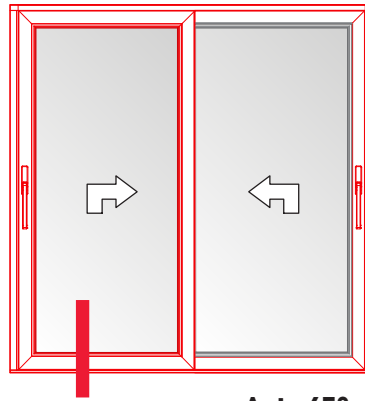

Anta 45°
45° Sash

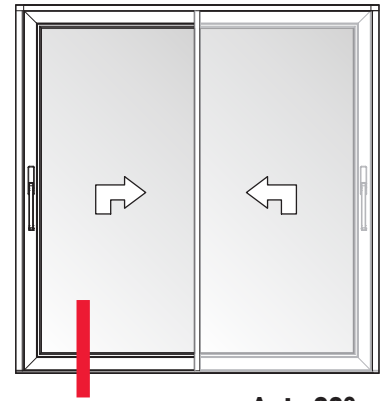

Anta 90°
90° Sash

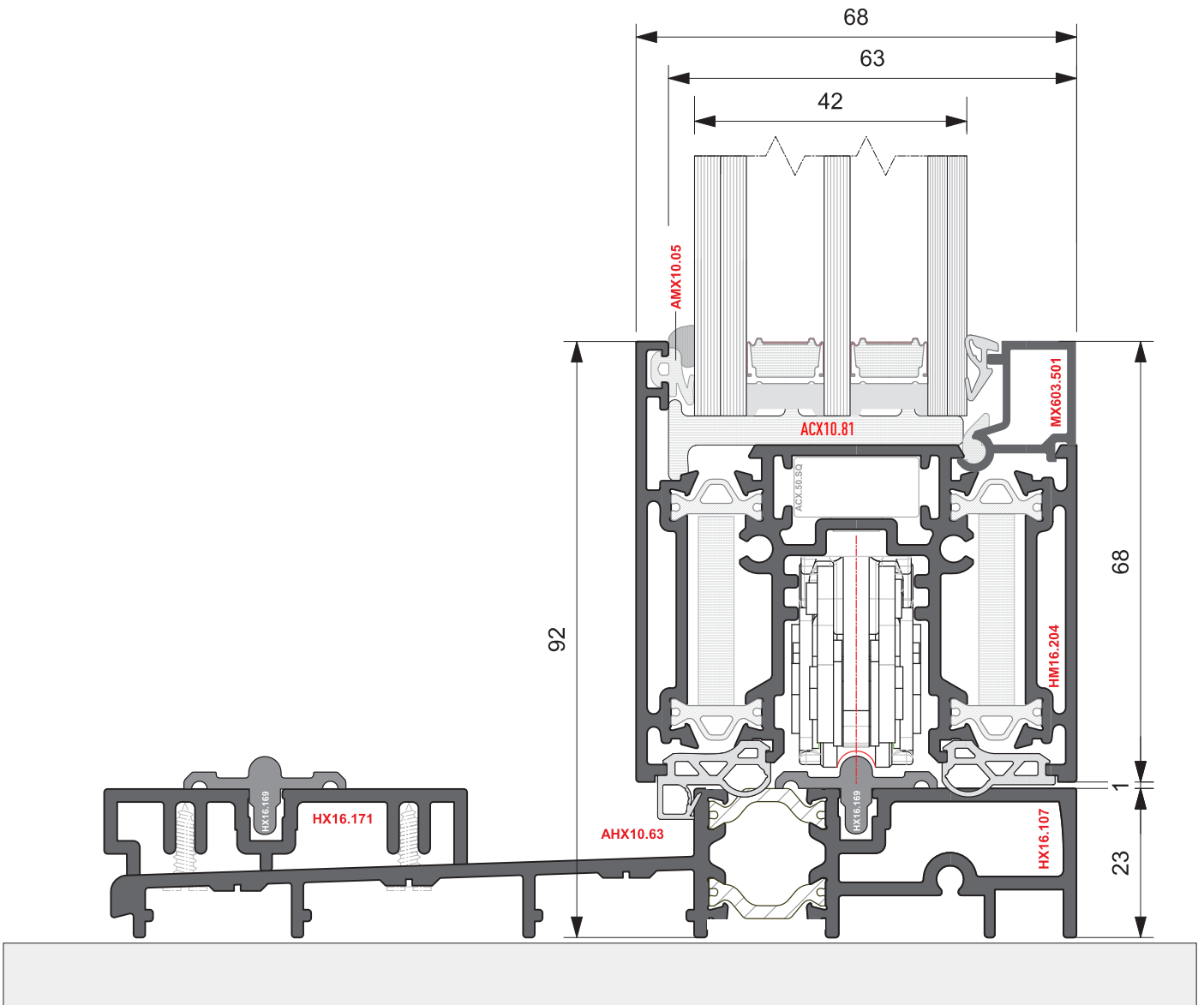



Anta mobile con fisso
Movable sash with fixed

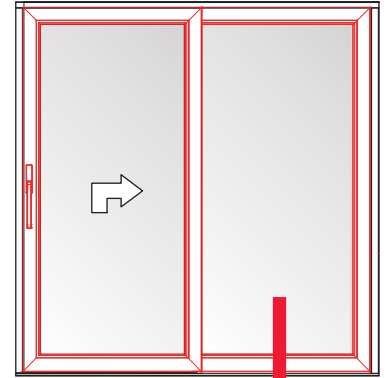

Anta 45°
45° Sash

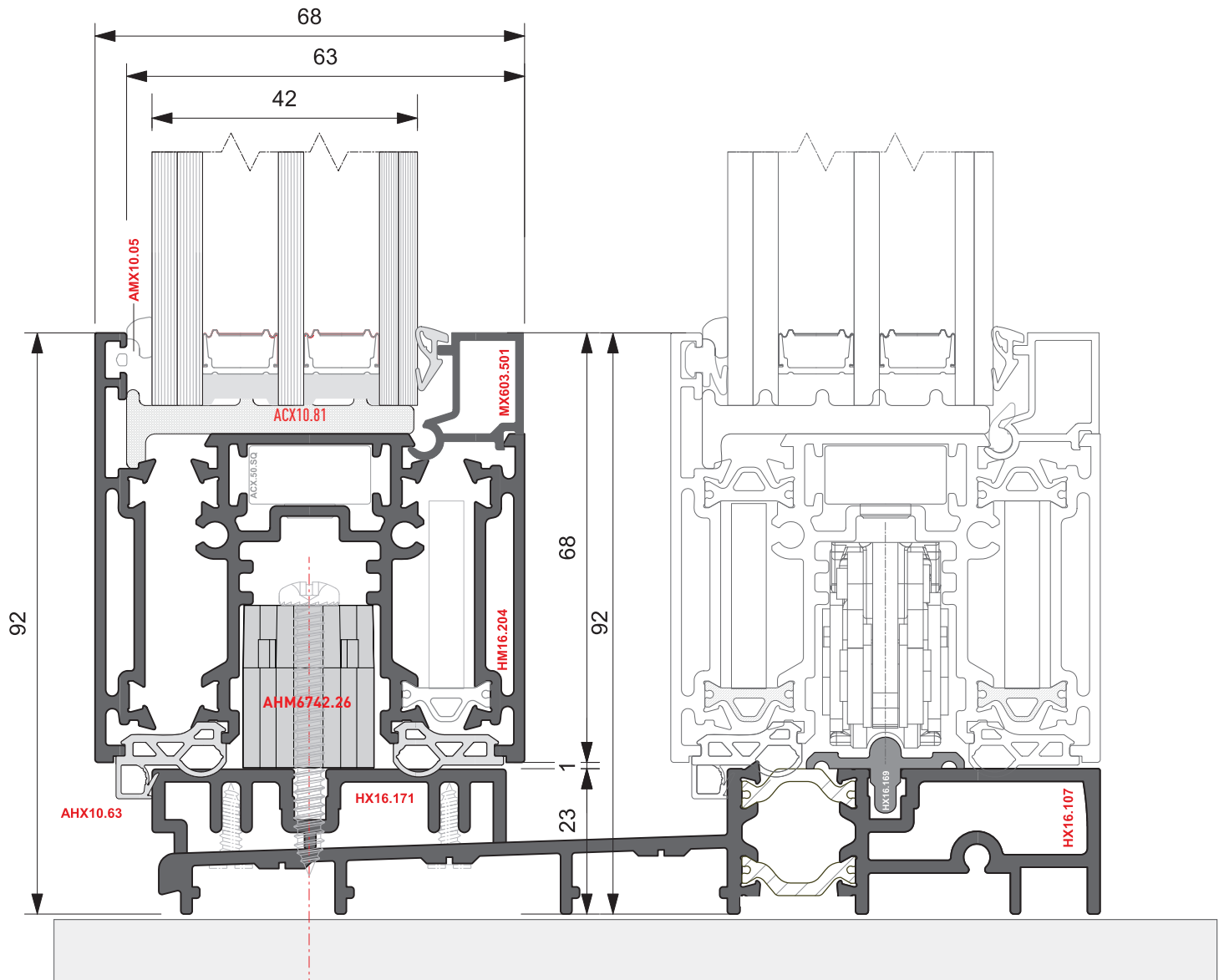



2 Ante mobili

2 Movable sashes

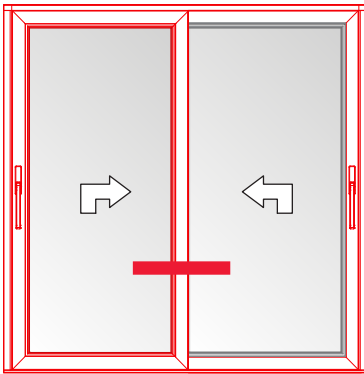

Anta 45°
45° Sash

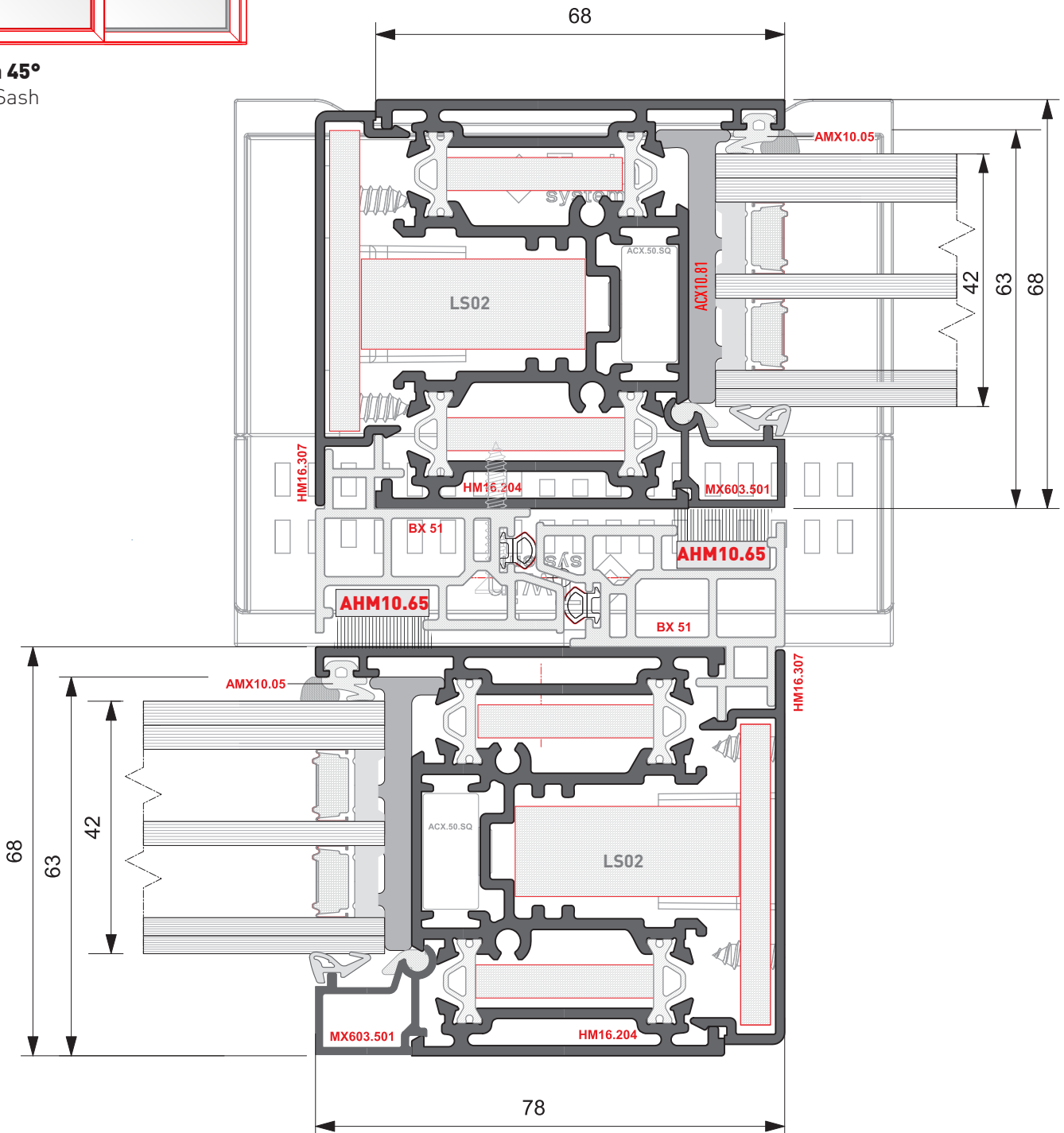



2 Ante mobili

2 Movable sashes

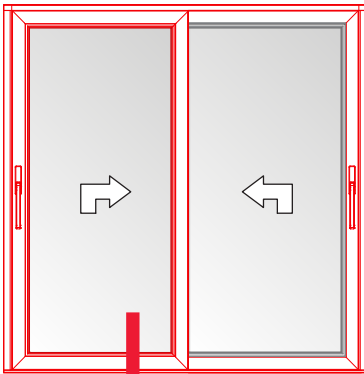

Anta 45°
 45° Sash

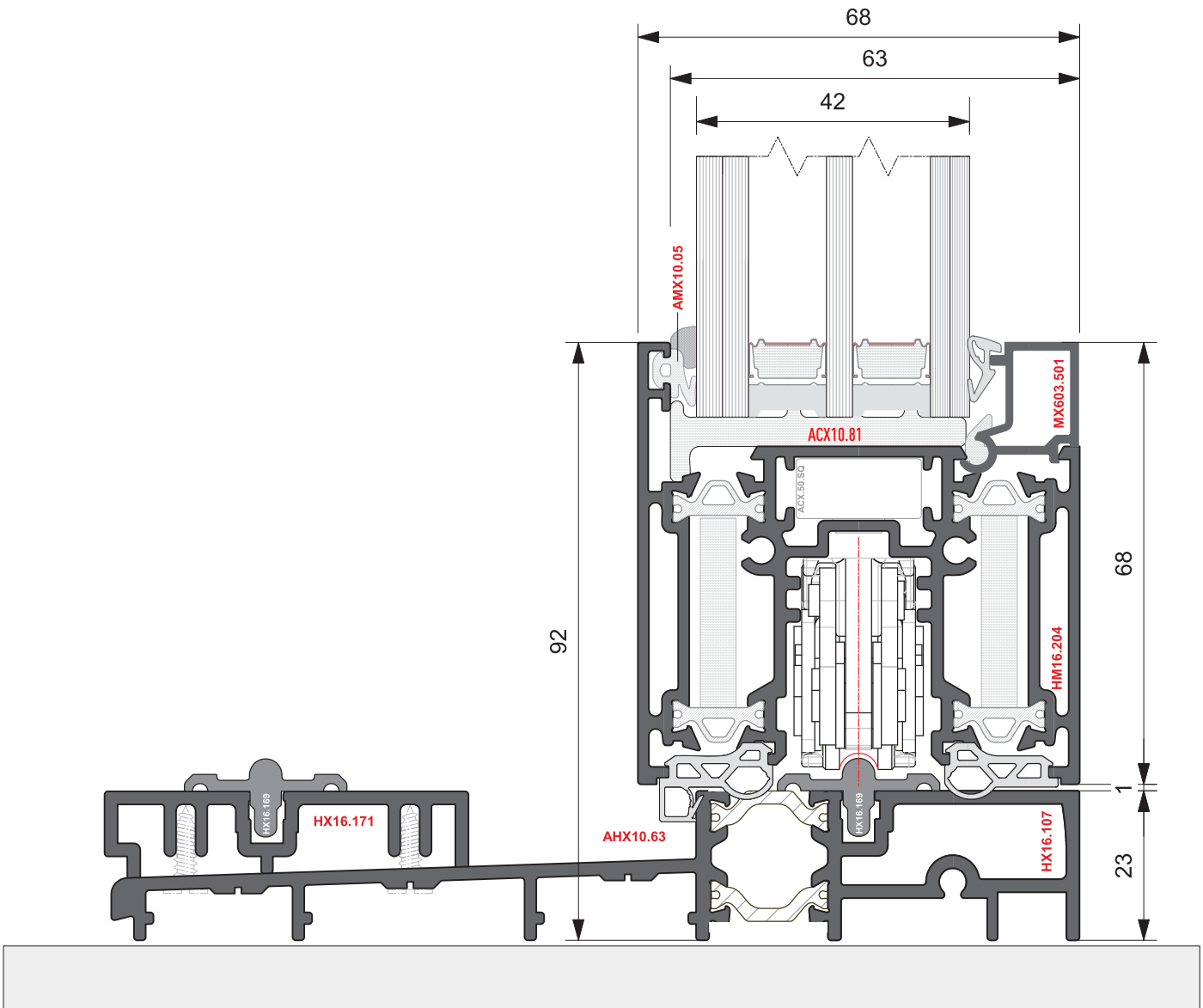



2 Ante mobili + 2 Ante Fisse
2 Movable Sashes + 2 Fixes Sashes

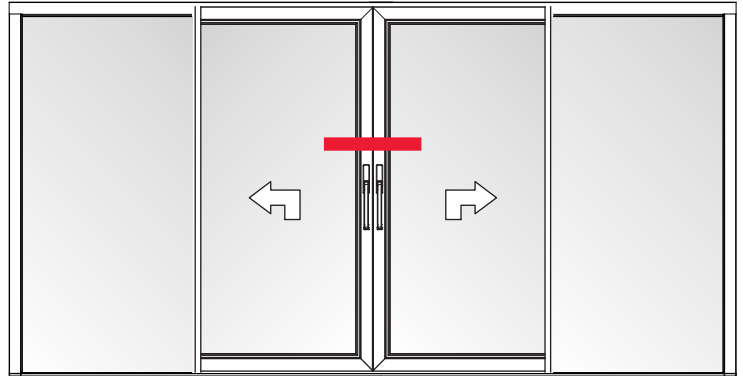

Anta 90°
90° Sash

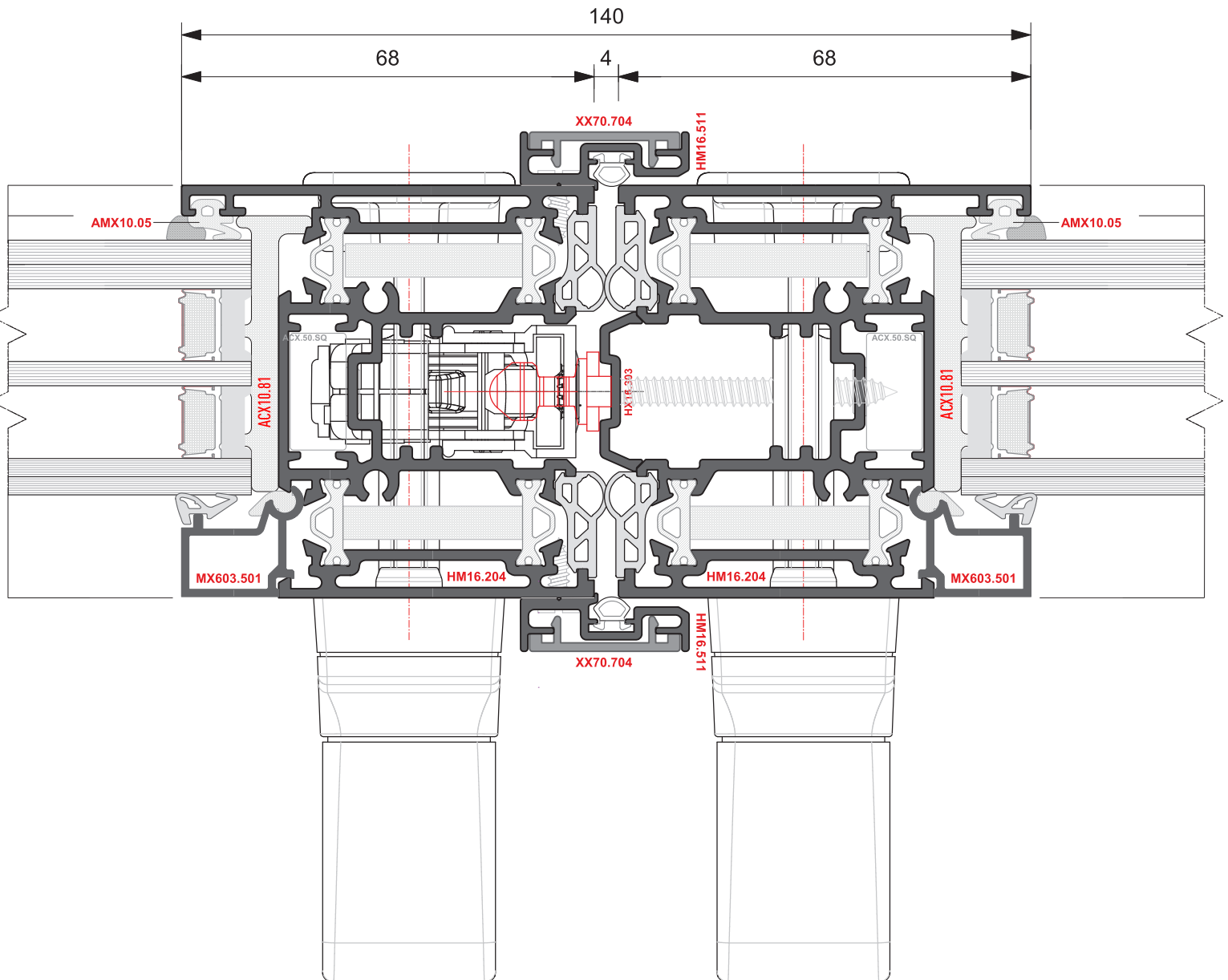



Soluzione d'Angolo

Corner Case

2 Ante mobili + 2 Ante Fisse
2 Movable Sashes + 2 Fixes Sashes

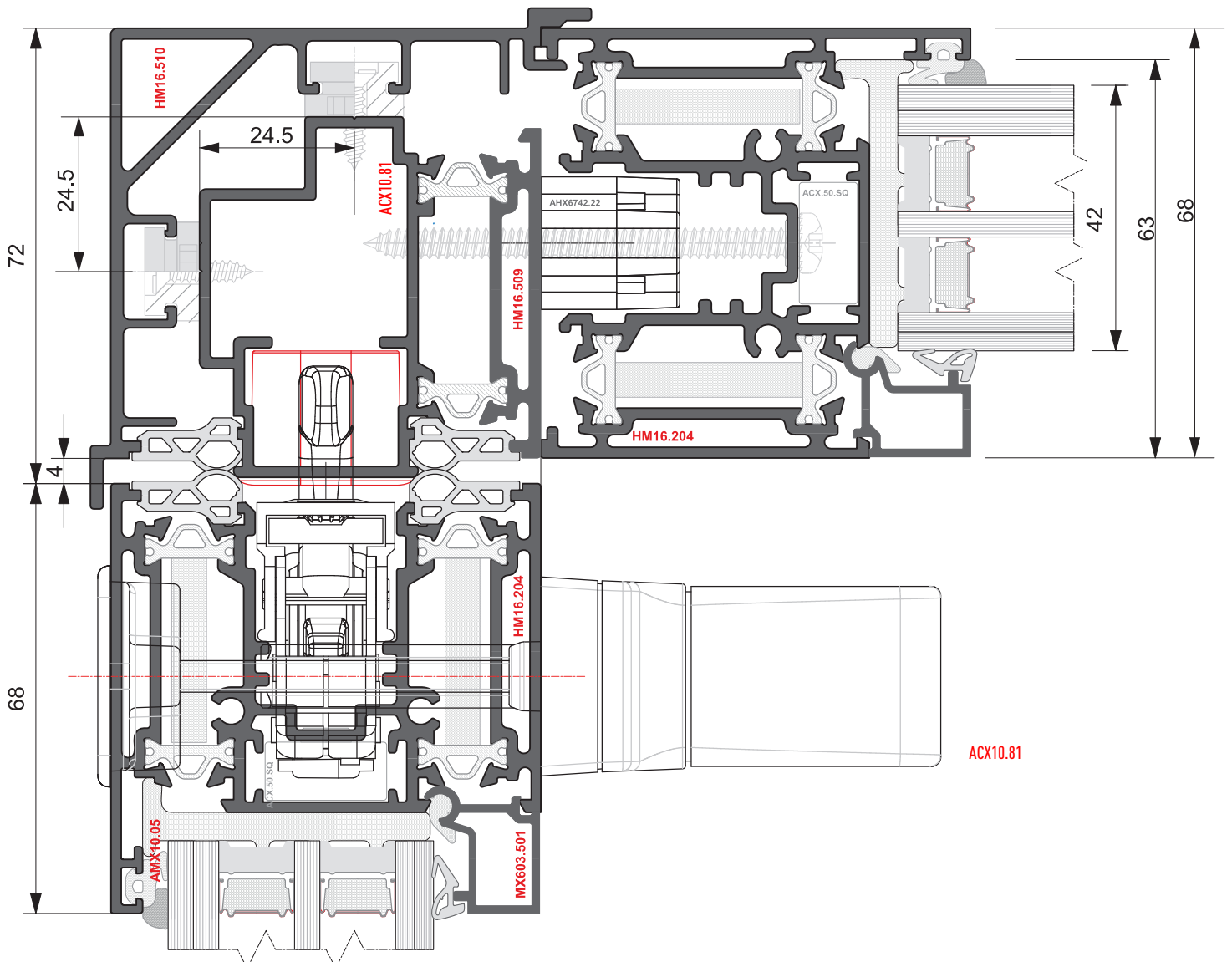
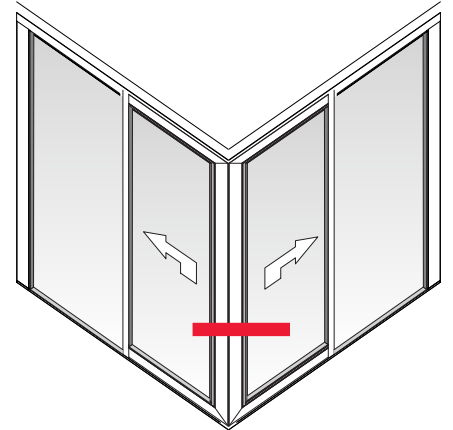



Soluzione d'Angolo

Corner Case

2 Ante mobili + 2 Ante Fisse

2 Movable Sashes + 2 Fixes Sashes

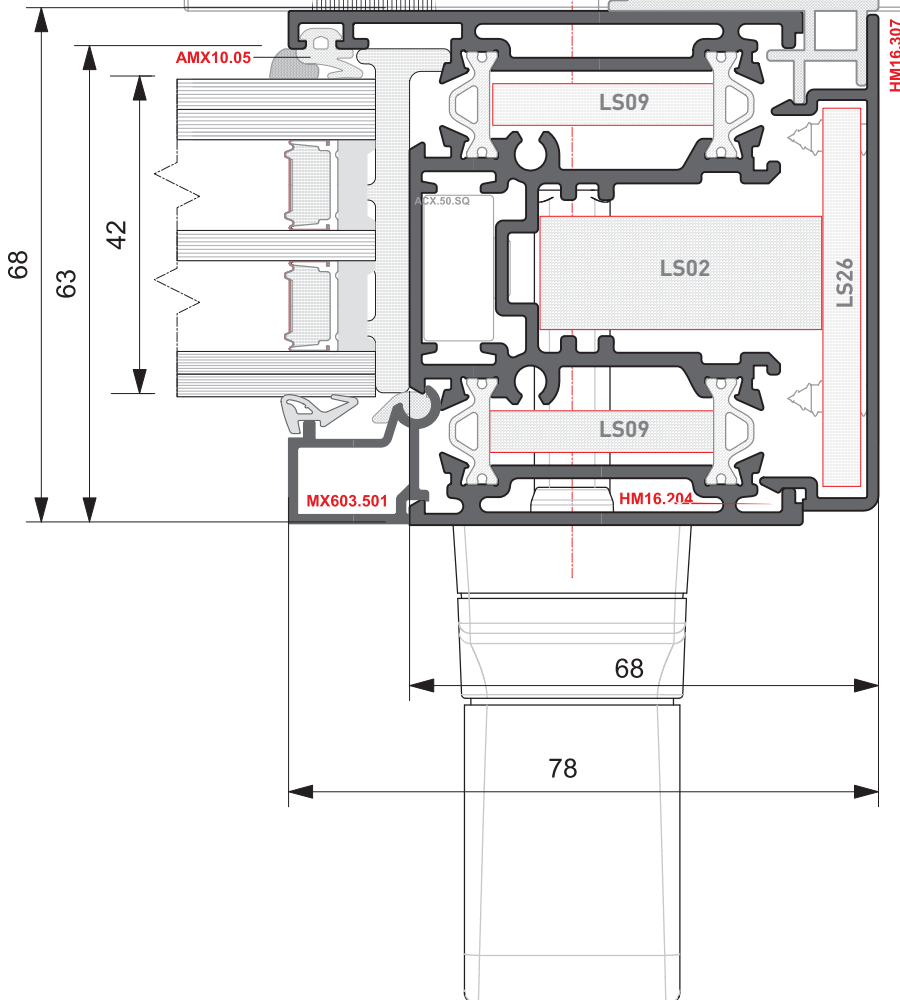
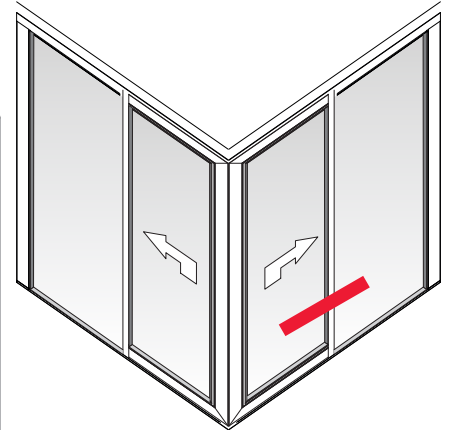
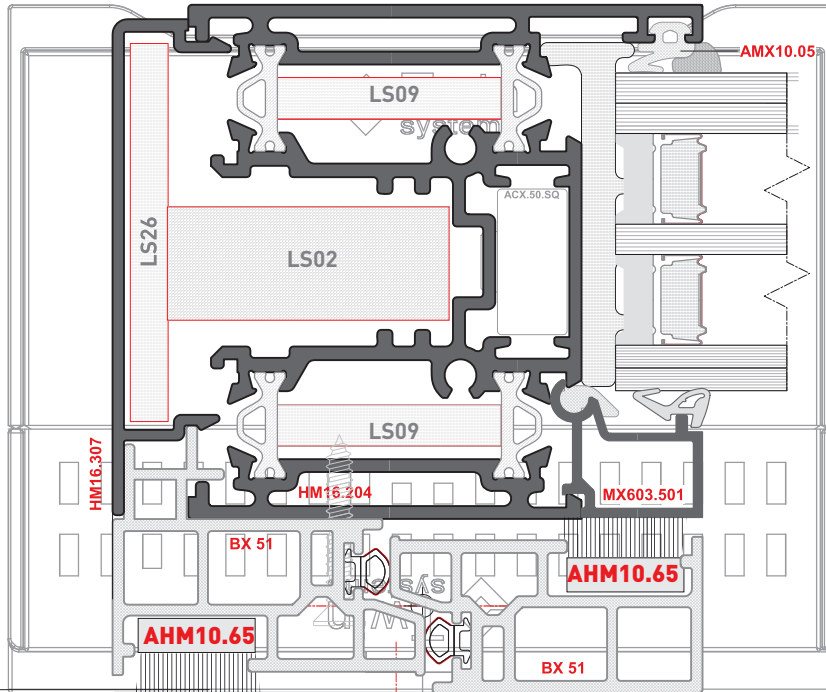

Soglia Filo Pavimento
Floor Level Threshold

2 Ante mobili
2 Movable sashes

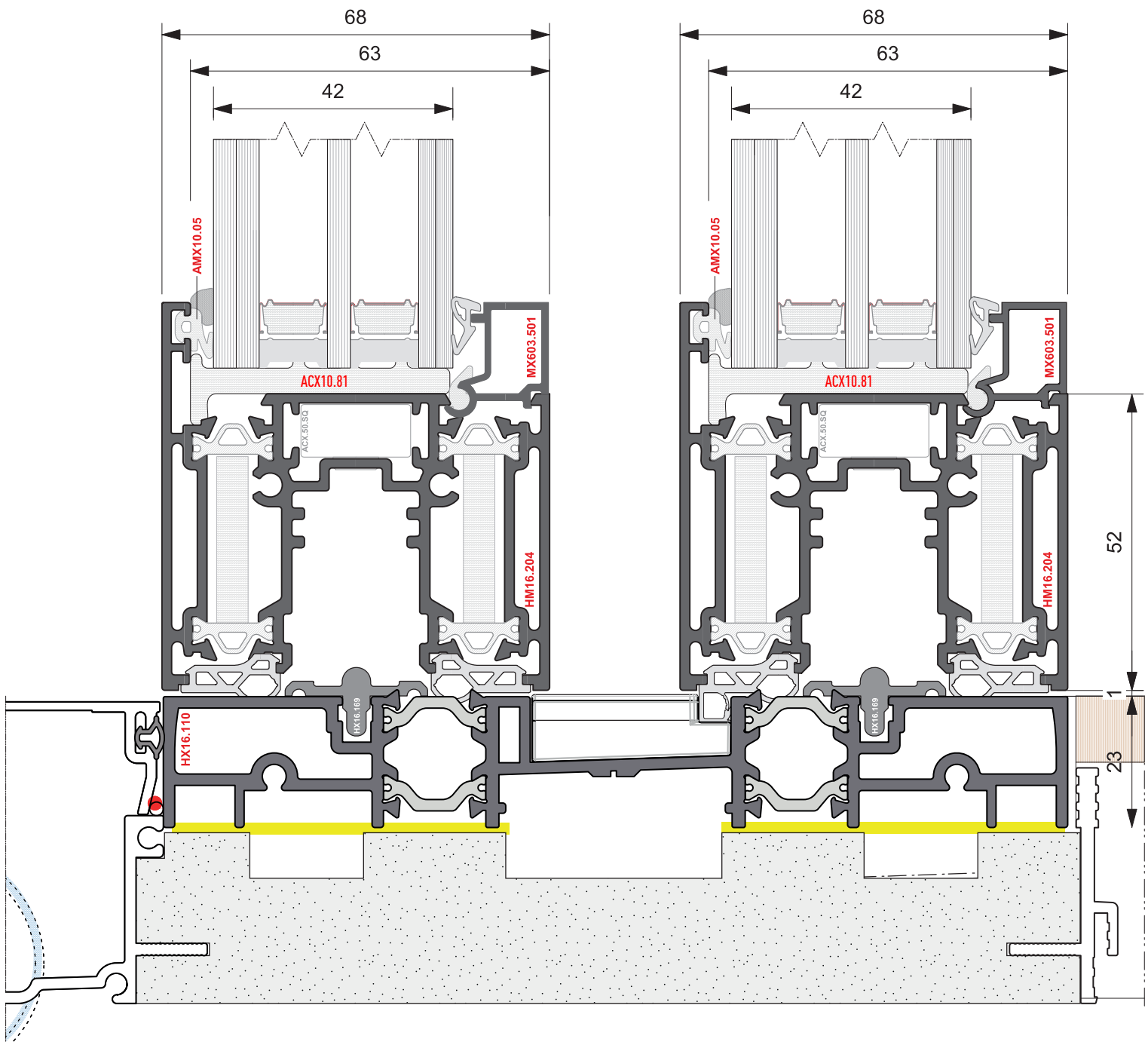
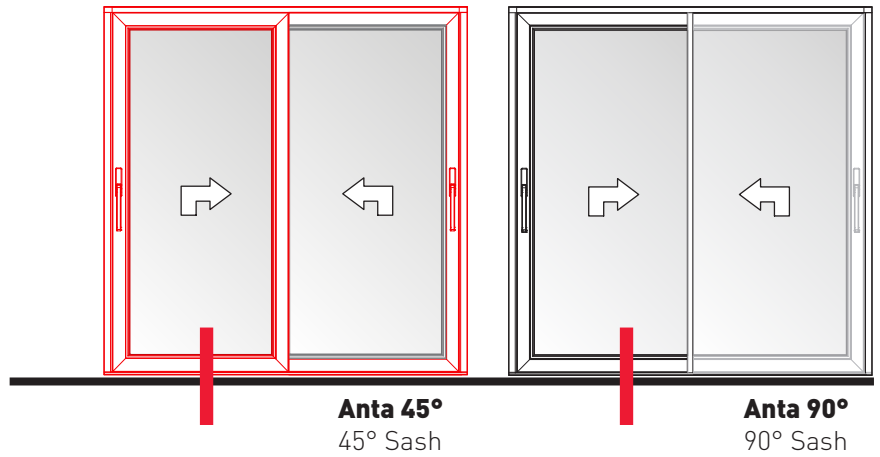



Soglia TERMICA
ThermicThreshold

ANTA FISSA + Anta MOBILE
1 Fixed Sash + 1 Movable Sash

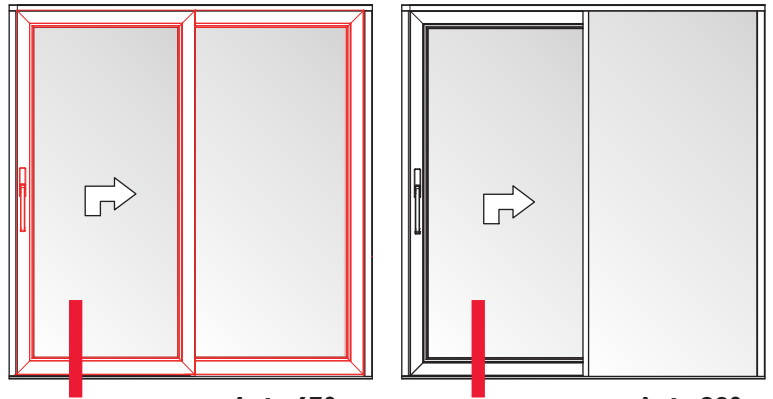

Anta 45°
45° Sash

Anta 90°
90° Sash

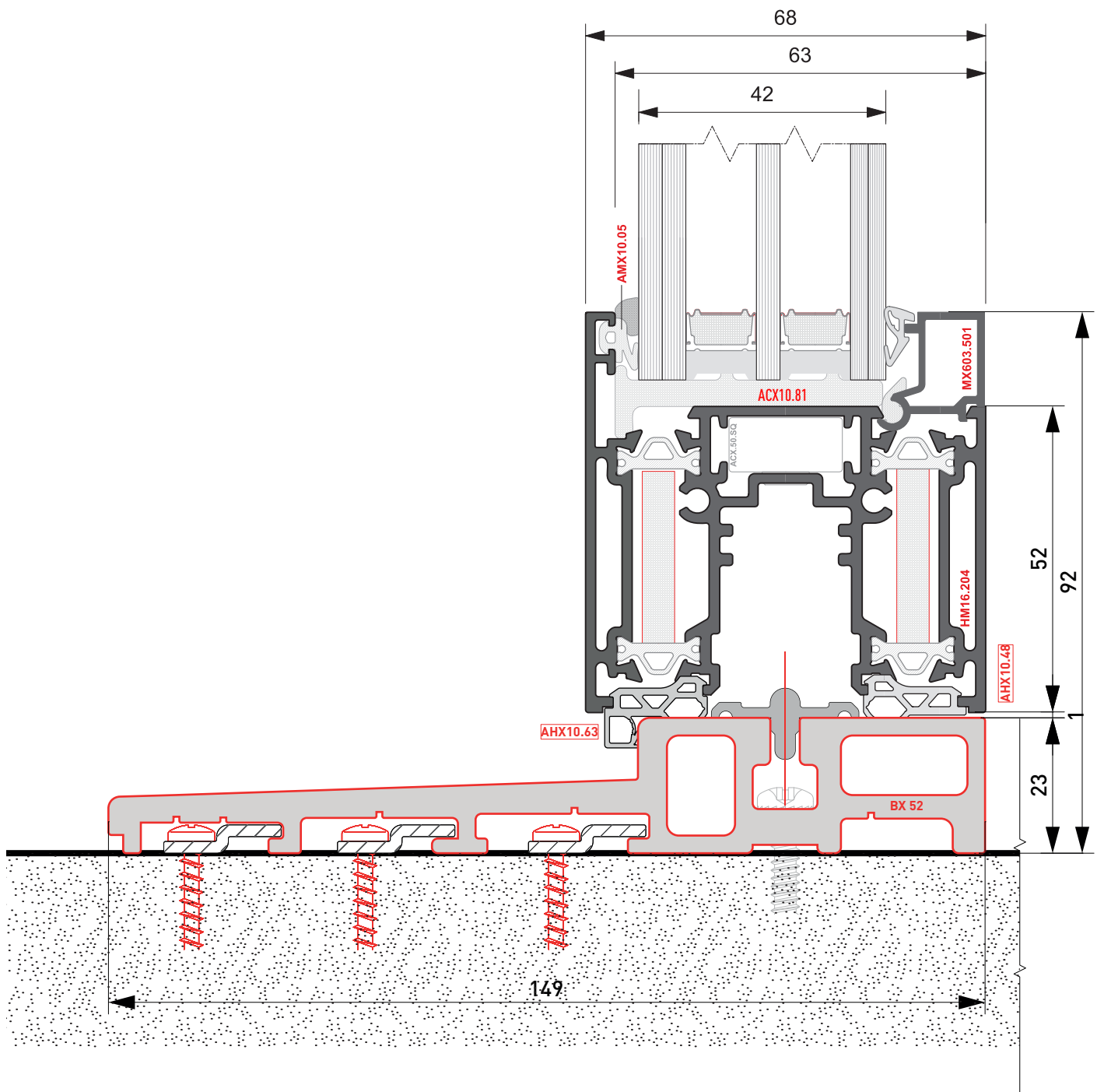



ANTA FISSA + Anta MOBILE
1 Fixed Sash + 1 Movable Sash

Soglia TERMICA

ThermicThreshold

VARIANTE 1 FILOPAVIMENTO
VARIATION 1 FLOOR LEVEL

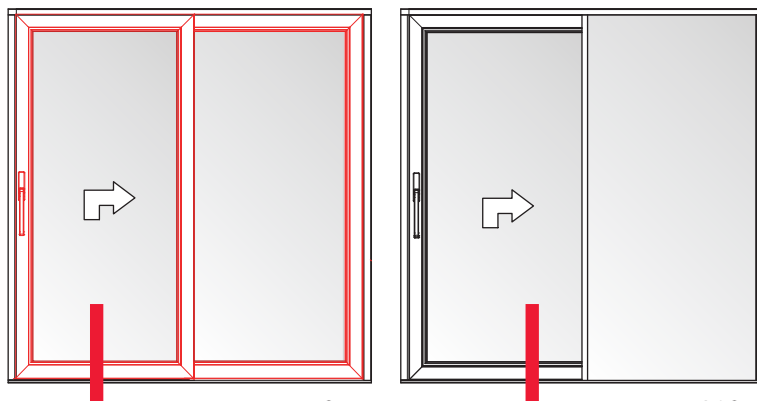

Anta 45°
45° Sash

Anta 90°
90° Sash

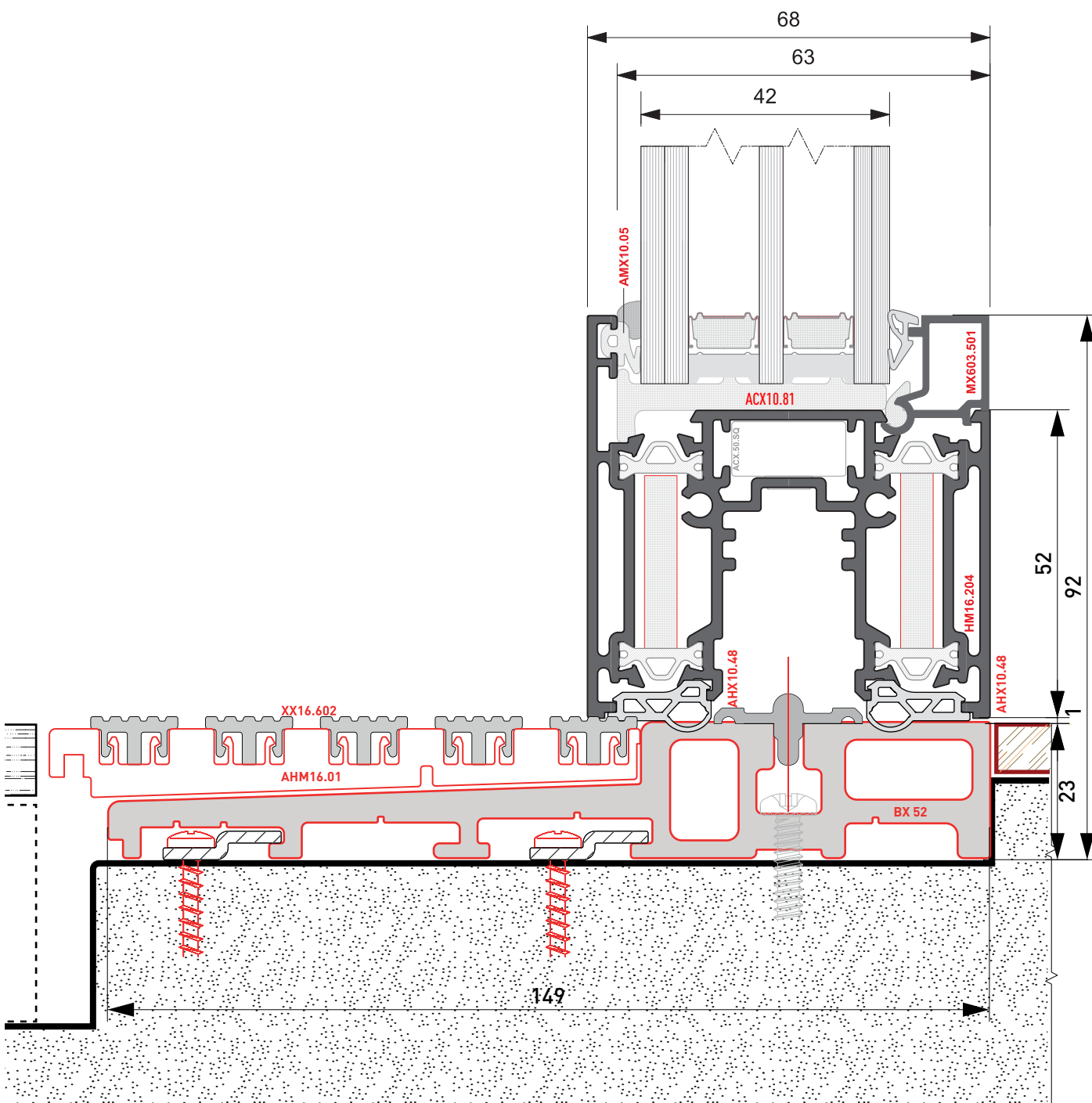

Soglia TERMICA
 ThermicThreshold

VARIANTE 2 FILOPAVIMENTO
 VARIATION 2 FLOOR LEVEL

2 Ante mobili
 2 Movable sashes

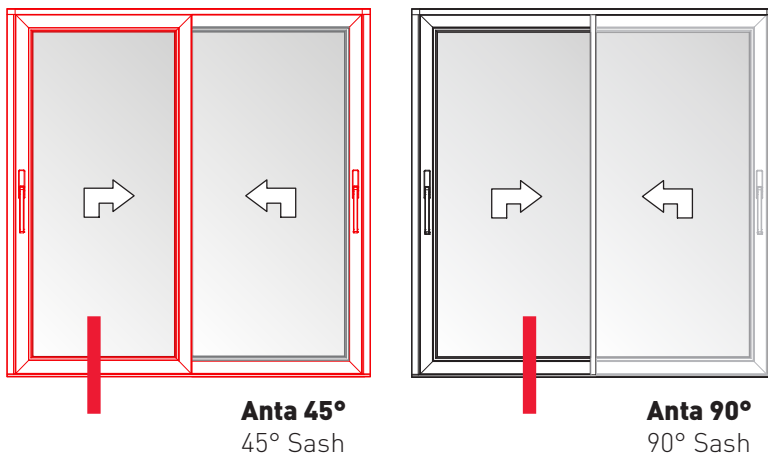

Anta 45°
 45° Sash

Anta 90°
 90° Sash

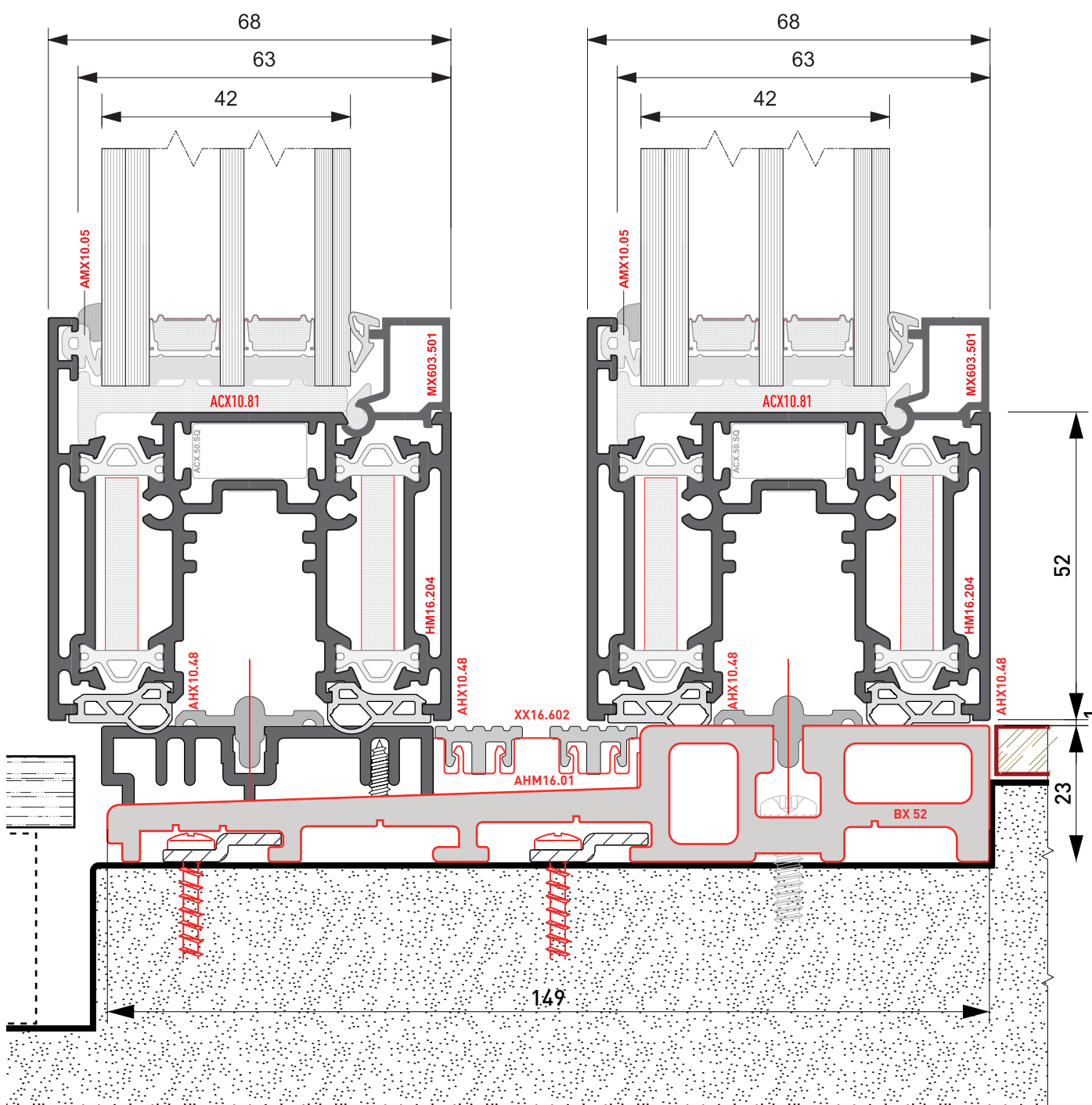



2 Ante mobili
2 Movable sashes

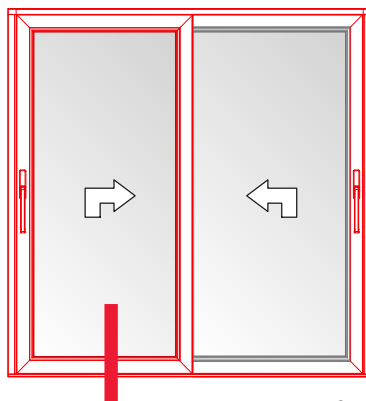

Anta 45°
45° Sash

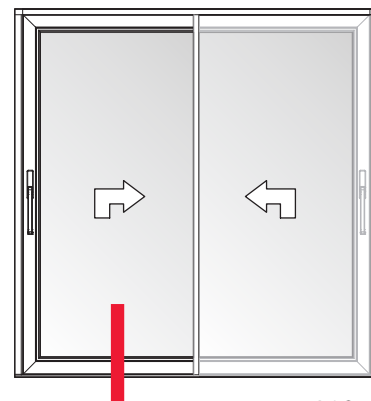

Anta 90°
90° Sash

Utilizzare coppia di AHM10.93
[Ingombro nodo 78mm]
Use a couple of AHM10.93
[Node Dimension 78 mm.]

Utilizzare singolo AHM10.93
[Ingombro nodo 36 mm]
Use a couple of AHM10.93
[Node Dimension 36 mm.]

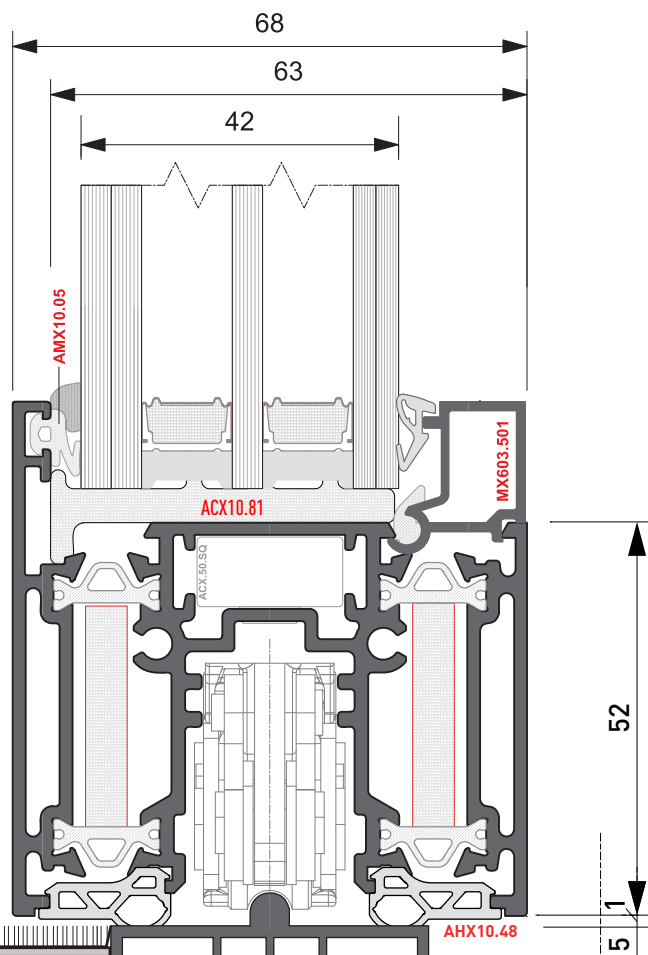
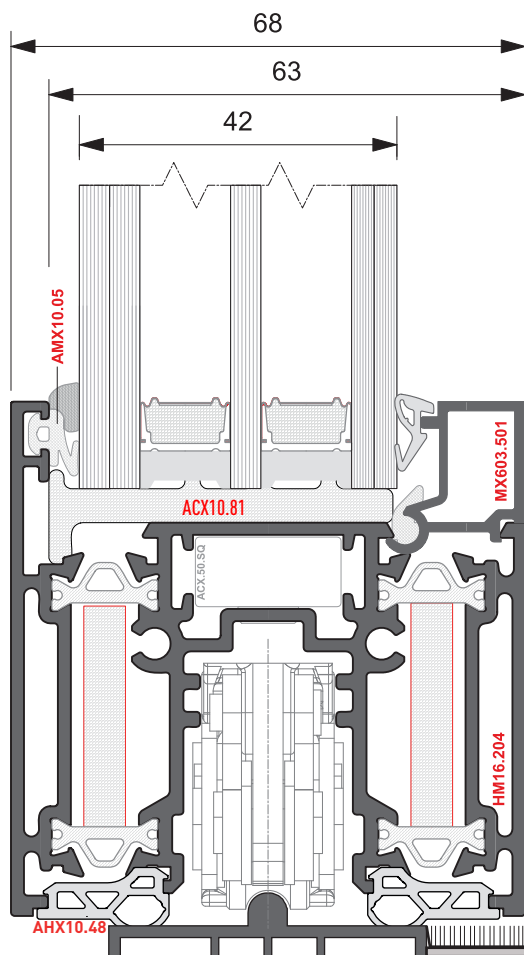

***Si RACCOMANDA l'utilizzo della soglia HX16.149 in presenza di copertura [tettoia pensilina etc..]. NON è PREVISTO DRENAGGIO**
*** Use HX16.149 threshold RECOMMENDED in the presence of a roof [canopy, shelter, etc..]. DRAINAGE IS NOT PROVIDED**



Anta mobile Incassata
Casket Door

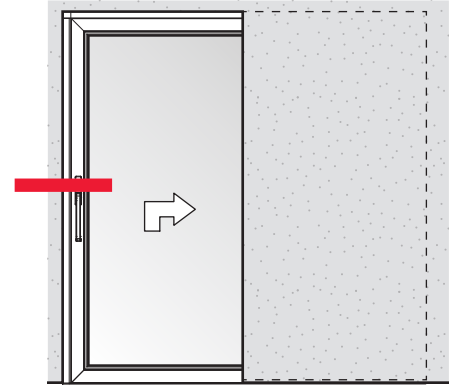

Anta 45°
45° Sash

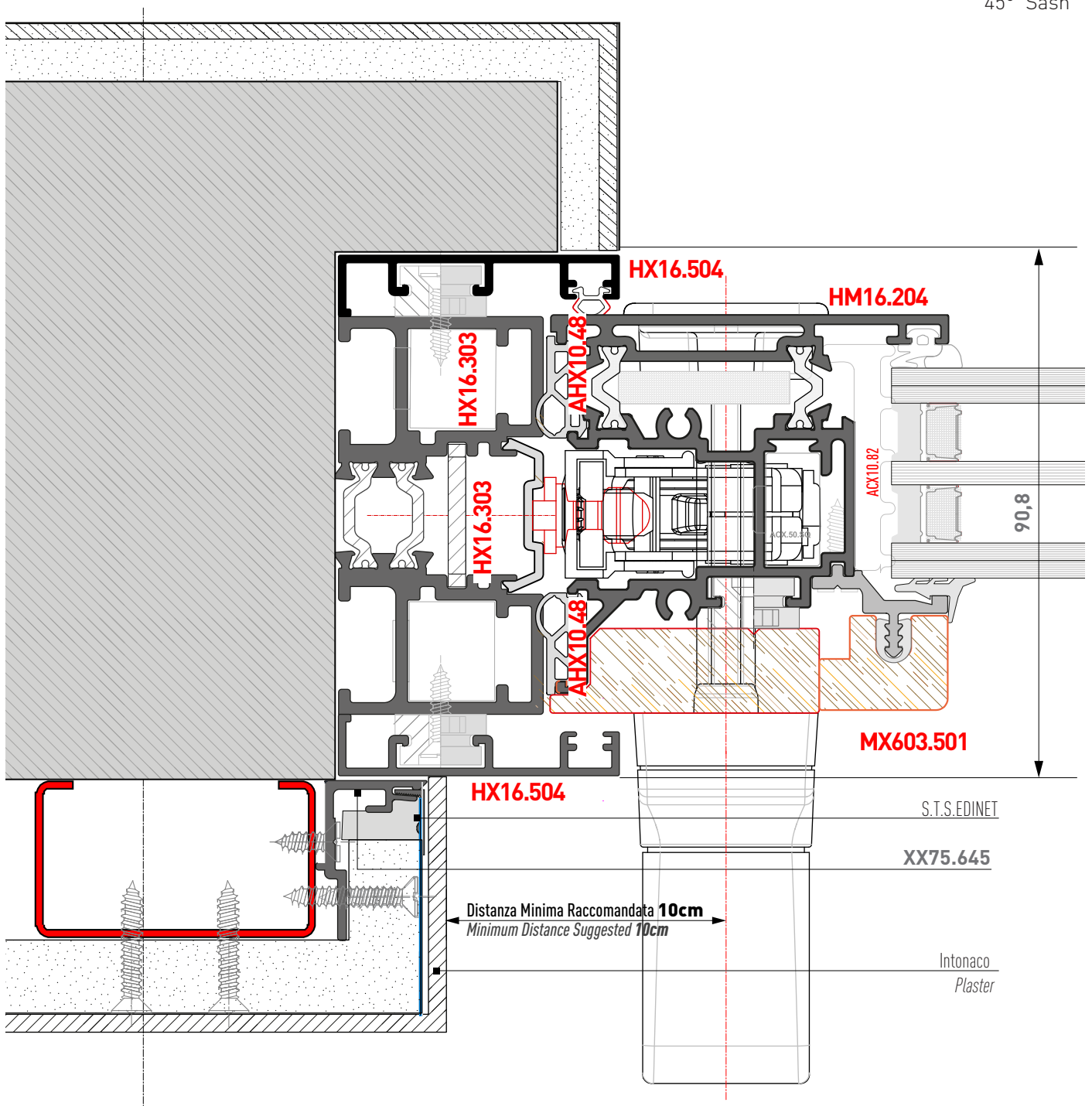



Anta mobile Incassata
Casket Door

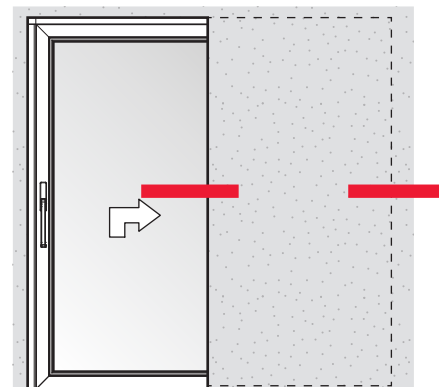

Anta 45°
45° Sash

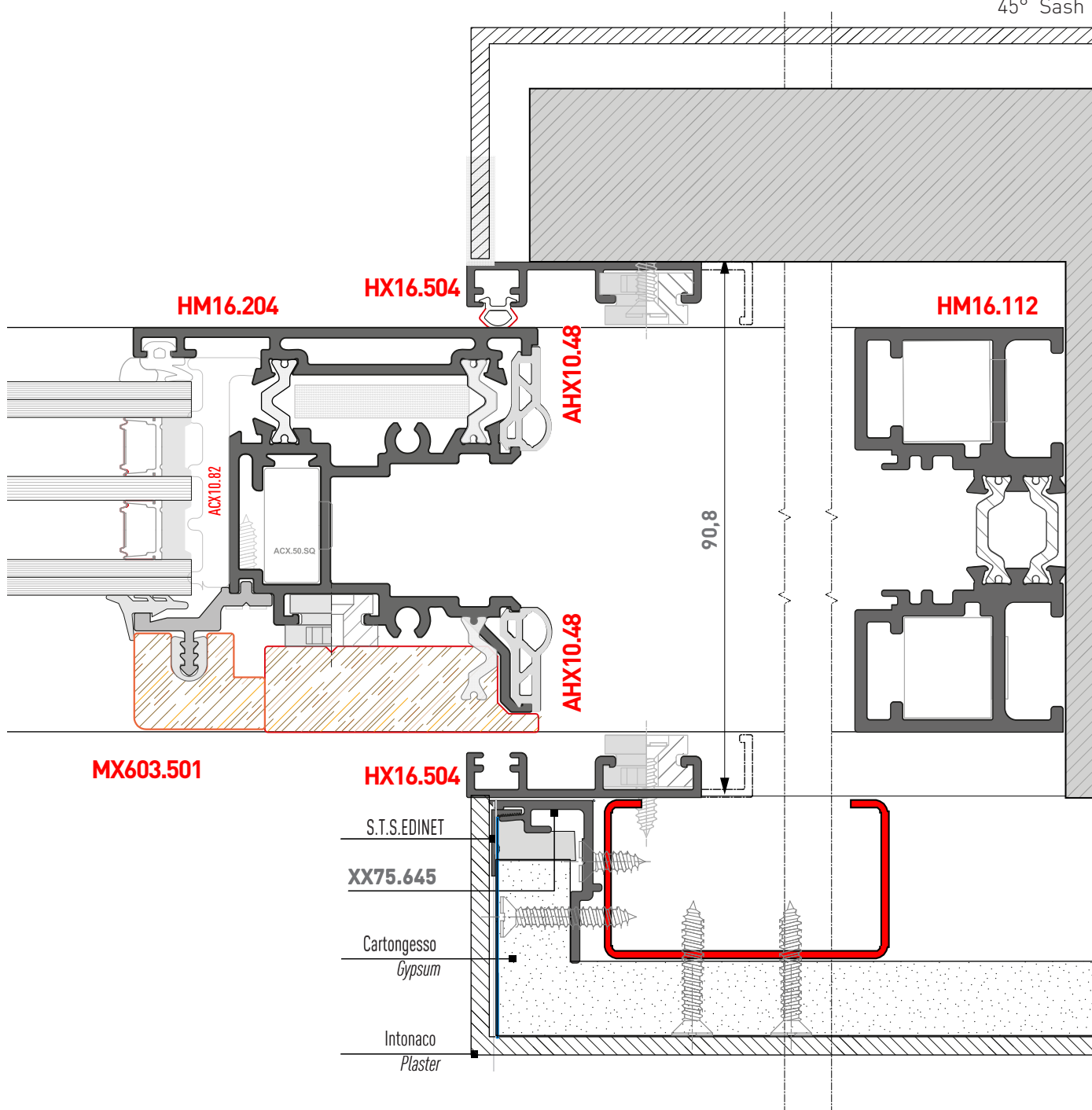



Doppia Anta 45° mobile Incassata
Casket Double 45° Door

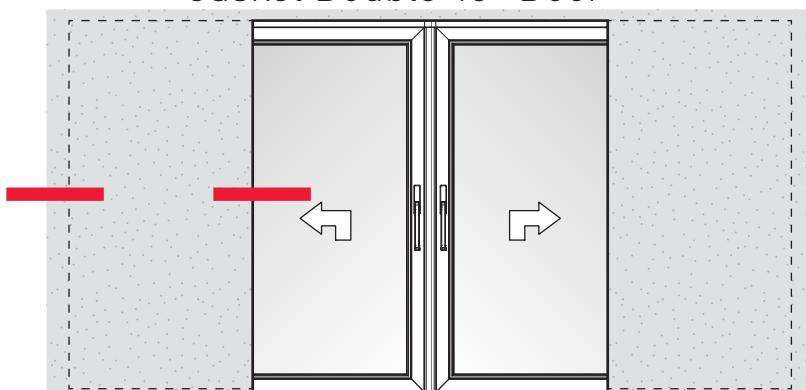
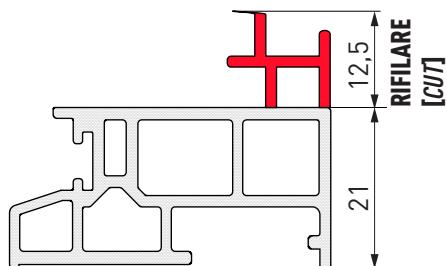

Anta 45°
Sash 45°

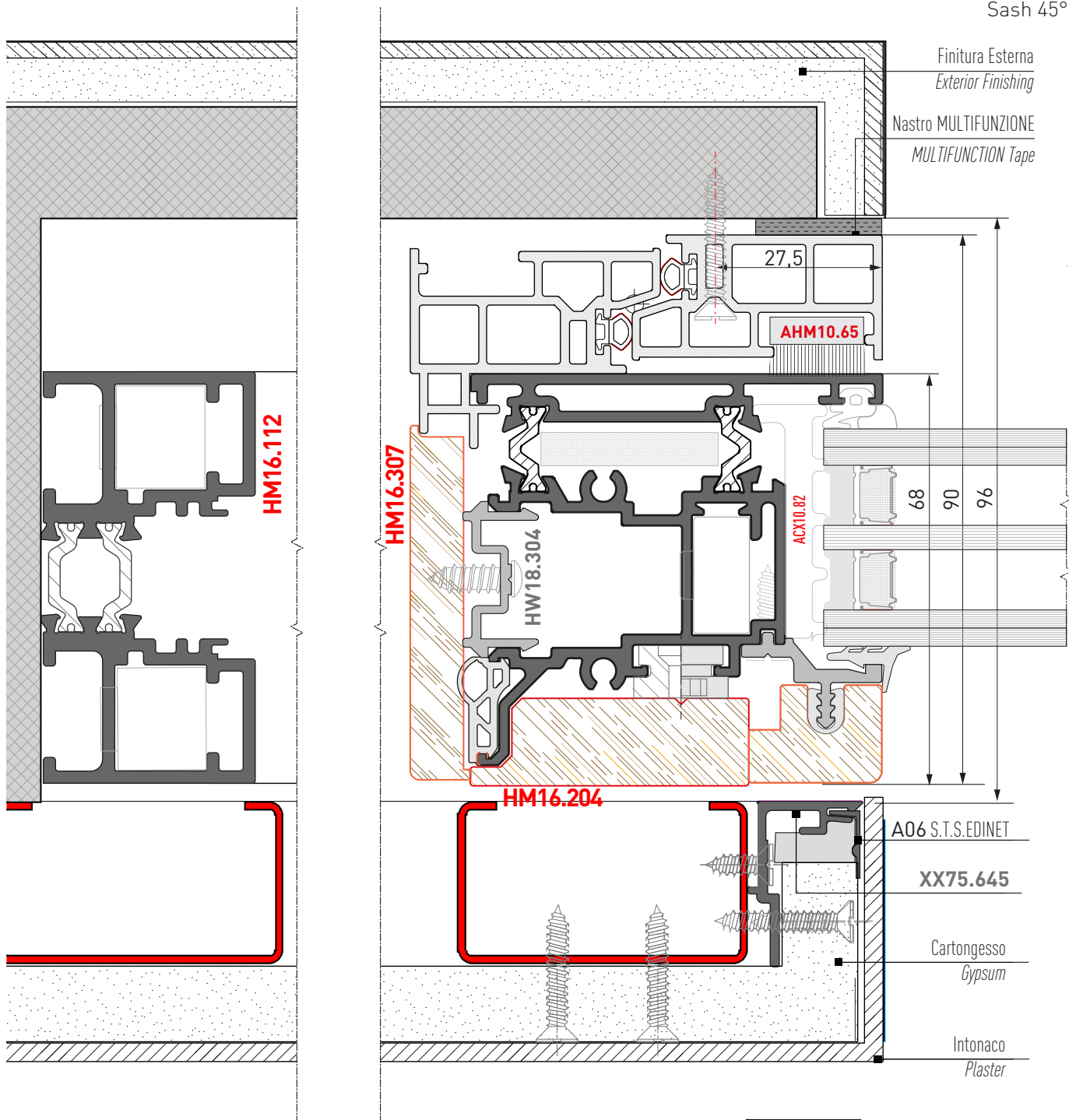



2 Ante mobili
2 Movable sashes

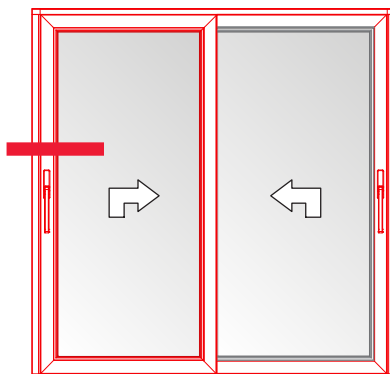

Anta 45°
45° Sash

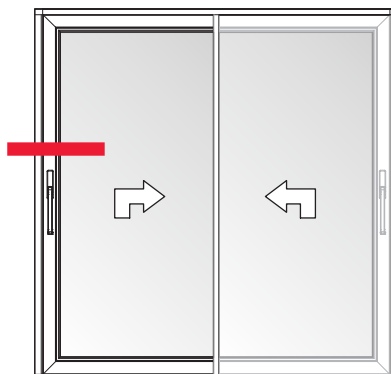

Anta 90°
90° Sash

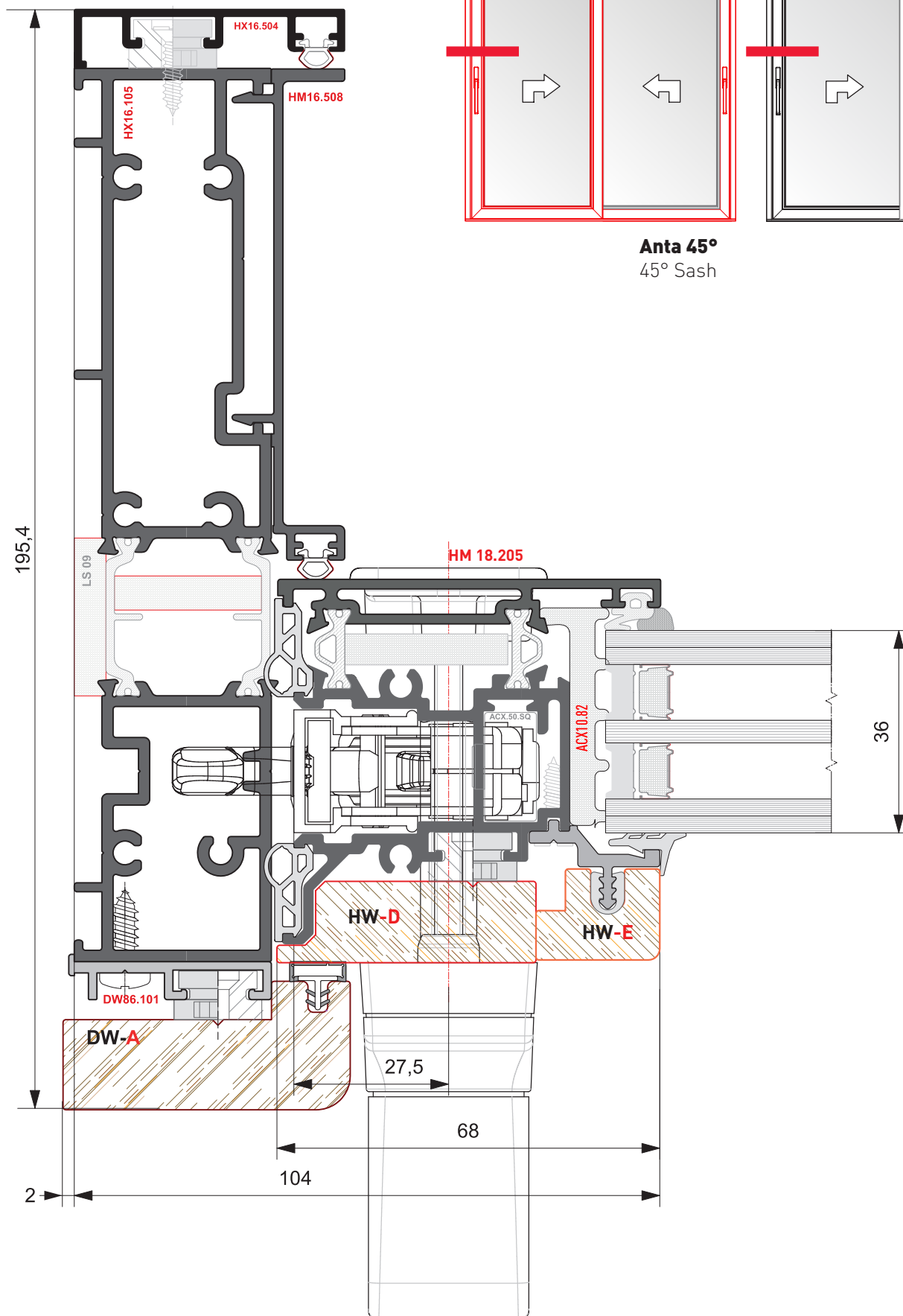



2 Ante mobili

2 Movable sashes

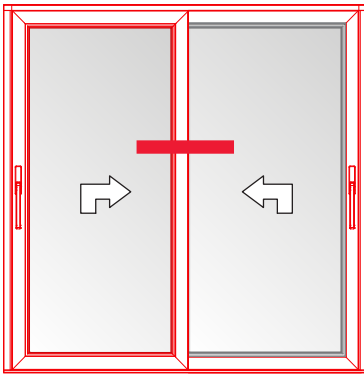

Anta 45°
 45° Sash

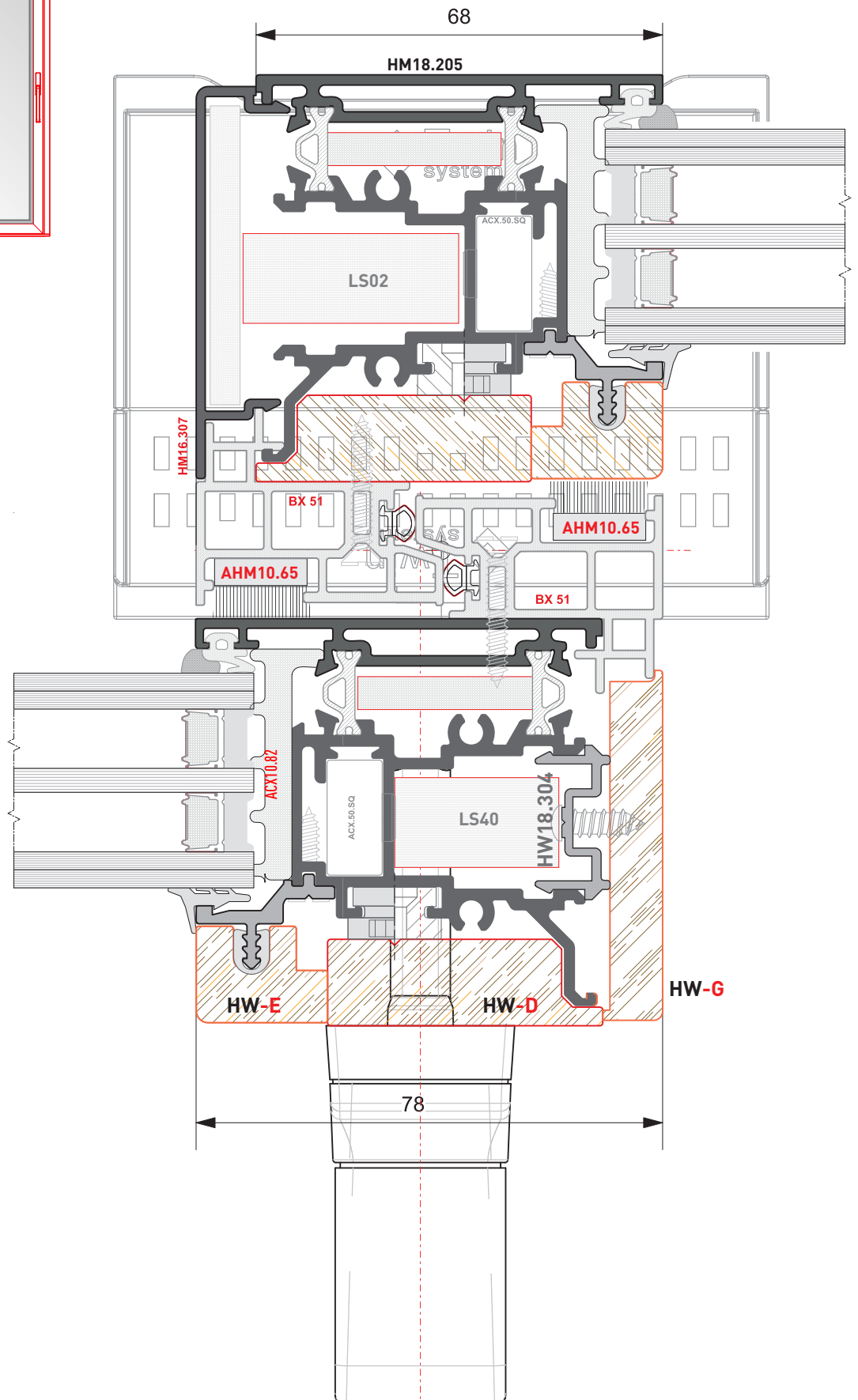



2 Ante mobili
2 Movable sashes

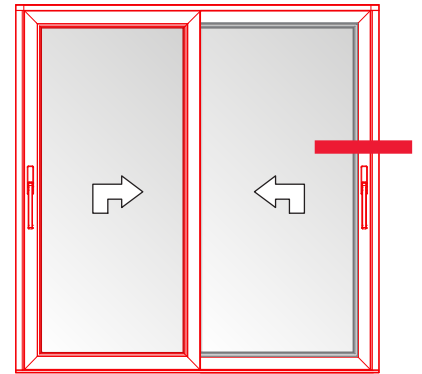

Anta 45°
45° Sash

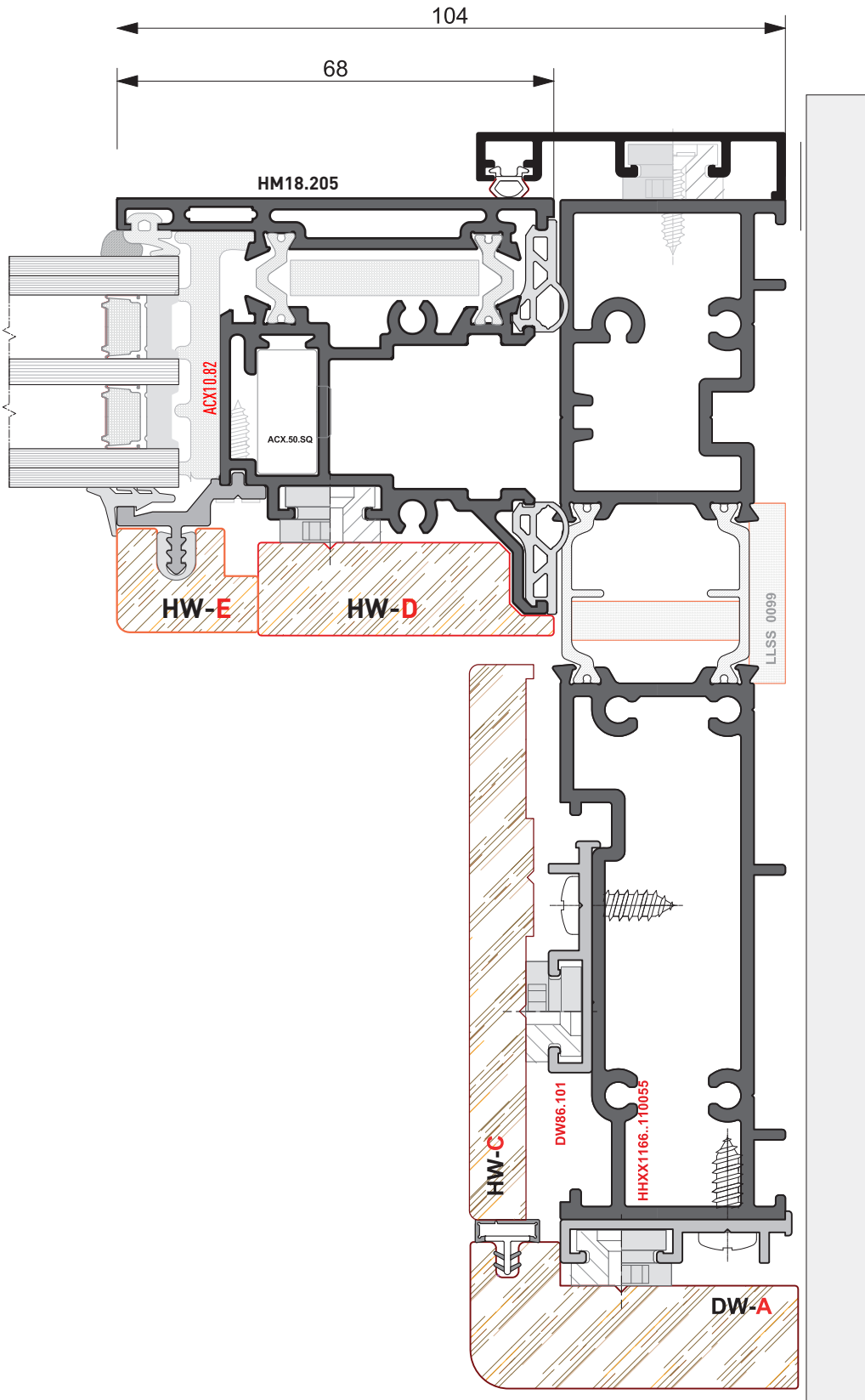

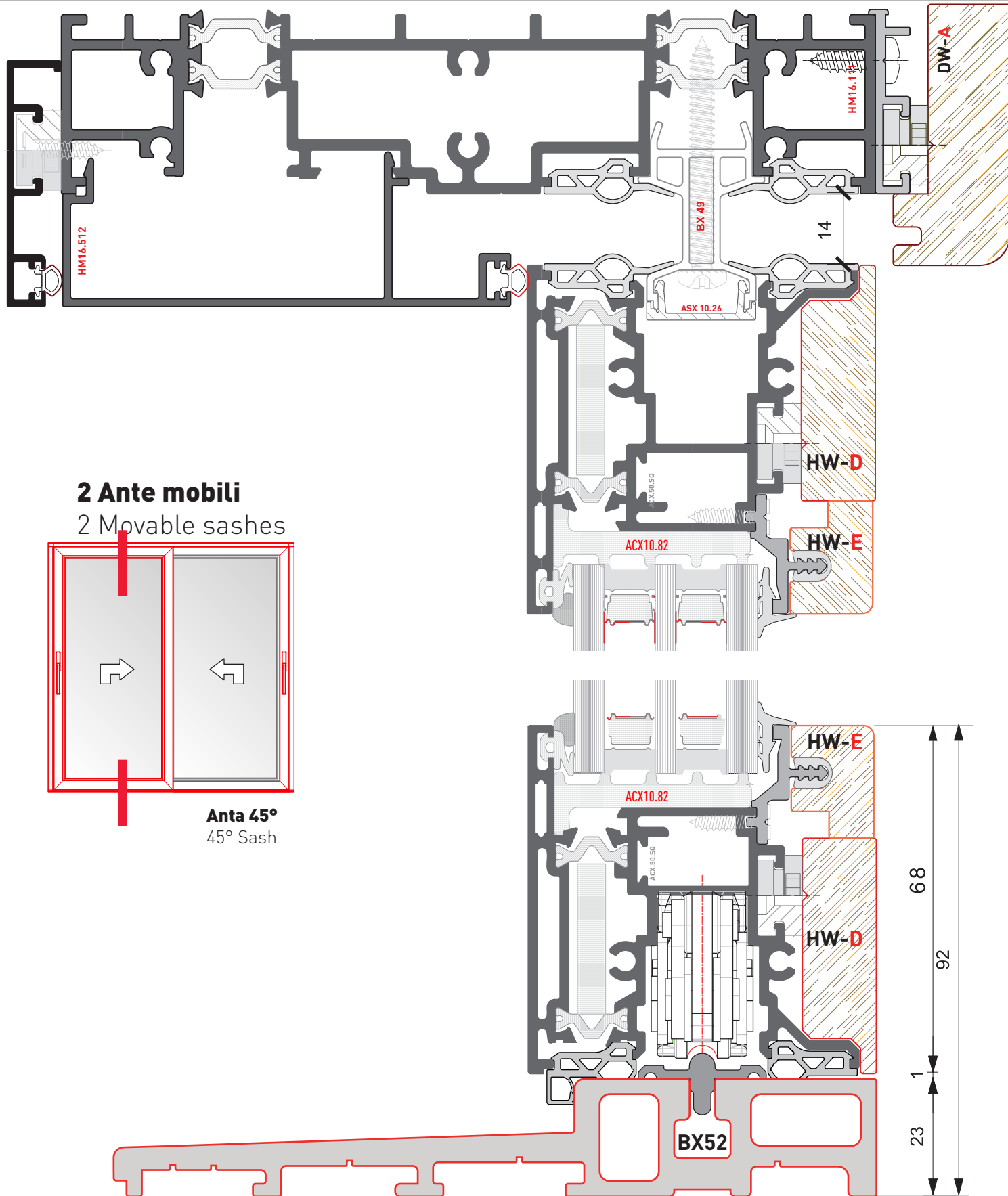

Soluzione d'Angolo
Corner Case



2 Ante mobili + 2 Ante Fisse
2 Movable Sashes + 2 Fixes Sashes

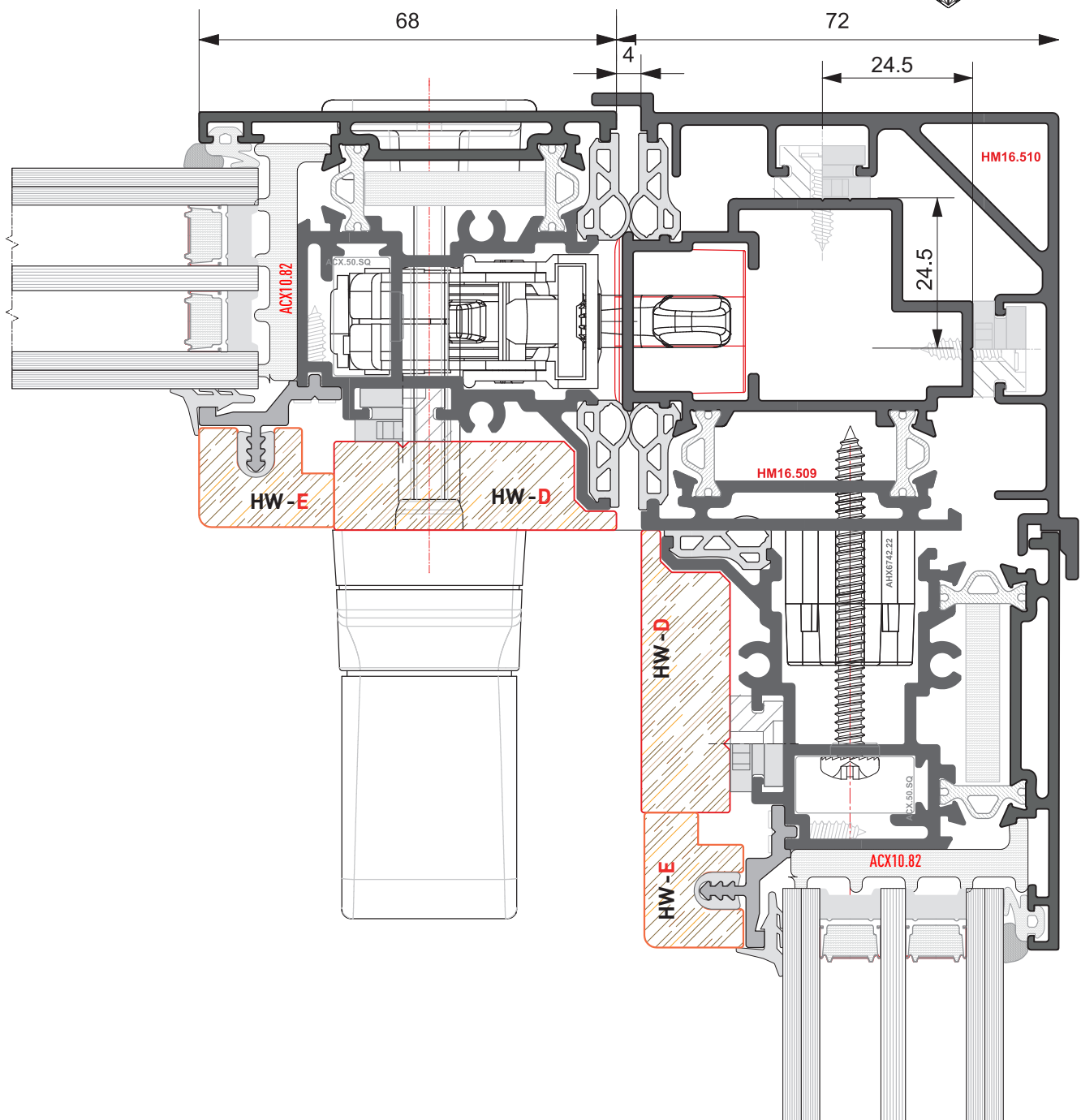
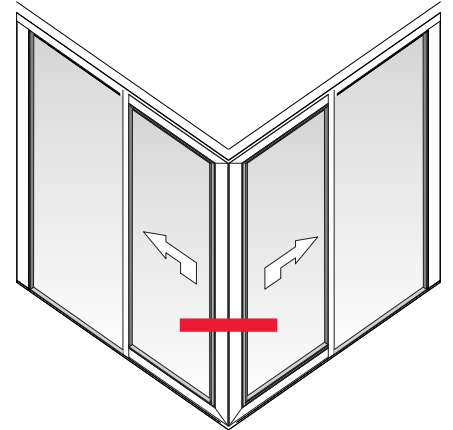



Tipologie
Types

Gruppo **E**

Assiemi e
Distinte di Taglio

*Assemblies &
Cut Lists*

Tipo 0 | 0 Type

1 ANTA INCASSATA - Versione 45°

SLIDING Casket Sash - 45° Version

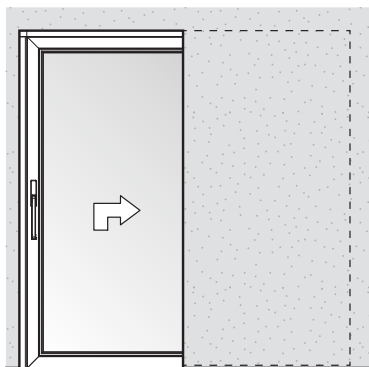

(Monoanta)

(Single Sliding Sash)

LISTA ACCESSORI | Accessories List

COMPLEMENTARI COMPLEMENTARIES	QT.	GUARNIZIONI GASKETS	QT.	KIT	QT.
LS 09		AMX 10.05	=MX603.501	AHM 16.6745.75	1
ACX 10.81	=MX603.501	ARX 10.1X	=MX603.501	AHM 16.6744.2*	1
AHX 6741.X	L _{Anta}	AHX 10.47	2L _{Anta}	AHM 16.6730.XX	1
ACX 06.04	1pz./50cm	AHX 10.48	4H + 1L _{Anta}		
ARX 43.SQ*	4 pz./Anta	AHX 10.63	L _{Anta}		
ARX 10.SQ*		ASX 10.69	4H + 2L _{Anta}		
AHM 70.SQ	8 pz./Anta	ACX 10.71	a pezzi		
ACX 50.SQ	4 pz./Anta				

*Opzionale

*Optional

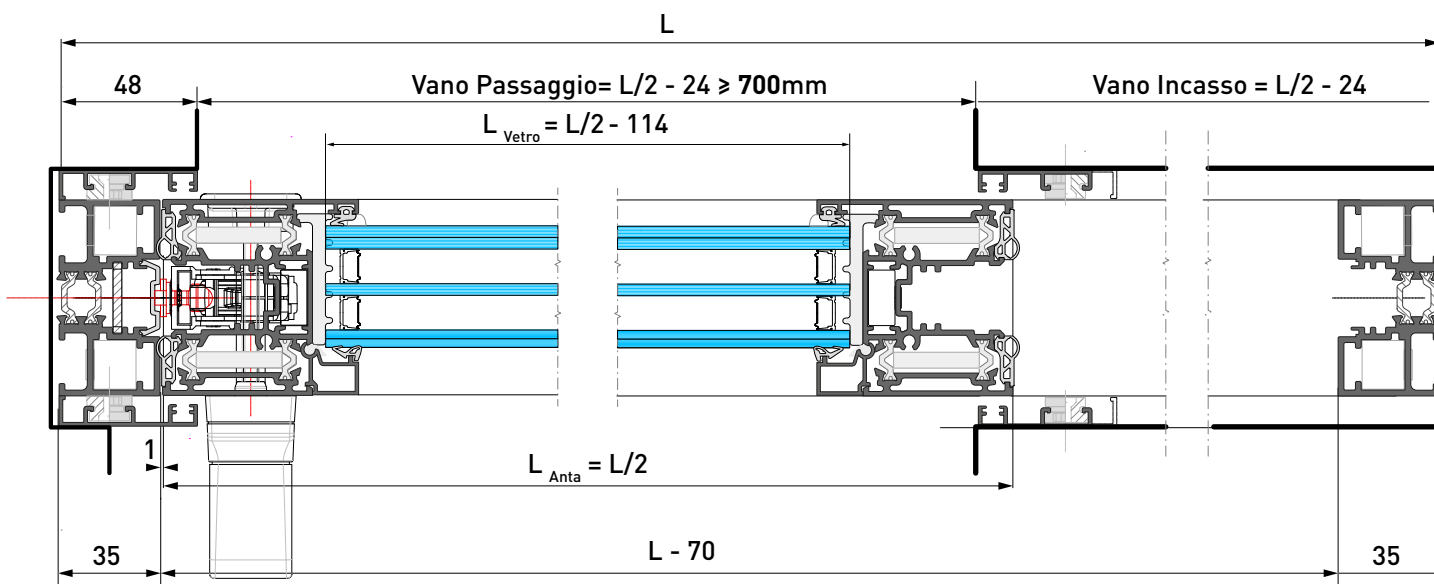
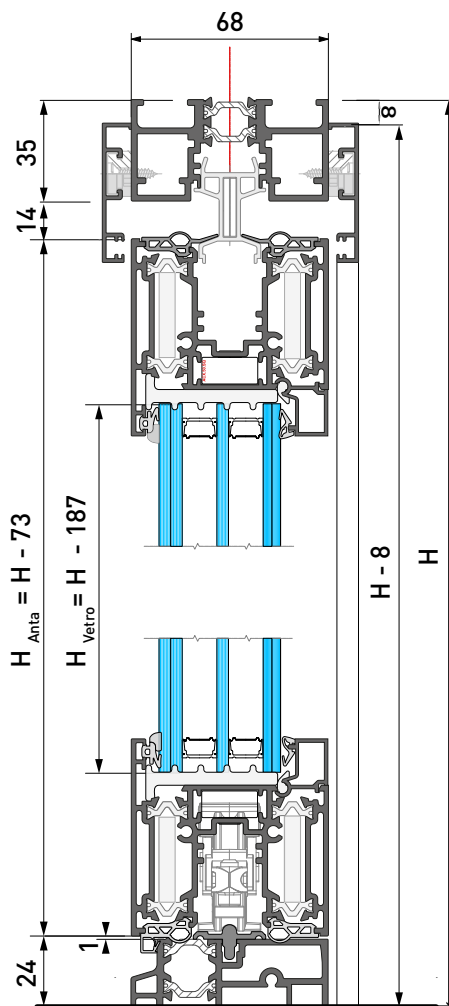

1 ANTA INCASSATA

Casket Door 1 Sliding Sash

Tipo 0 | 0 Type
(1 Anta Mobile)
 (1 Mobile Sash)

ART. Item	PROFILO Profile	DESCRIZIONE Description	DIM Size	TIPO TAGLIO Cut Type	QT
HM16.112		Telaio Traverso Superiore <i>Frame. Upper Transom</i>	L		1
		Telaio. Montante <i>Frame. Mullion</i>	H		2
HX16.108*		Soglia <i>Threshold</i>	L - 70		1
HX16.169		Binario <i>Rail</i>	L - 70		1
HX16.504		Carter Coprifilo <i>Finishing Carter</i>	L/2 - 24		2
			H - 8		4
BX49		Guida Superiore <i>Upper Guide Rail</i>	L - 70		1
MX603.501		Fermavetro <i>Glass holder</i>	L/2 - 104		2
			H - 209		2
ASX10.26		Finitura BX49 <i>BX49 Finishing</i>	L - 70		1
HX16.303		Profilo di Supporto <i>Support Profile</i>	H - 58		2
HM16.204		Anta <i>Sash</i>	L/2		2
			H - 73		2

* In alternativa utilizzare variante profilo HM16.113

* Alternative can use version profile HM16.113

Tipo A | A Type

1 ANTA MOBILE - Versione 90°

SLIDING Sash + Glazing Wall - 90° Version

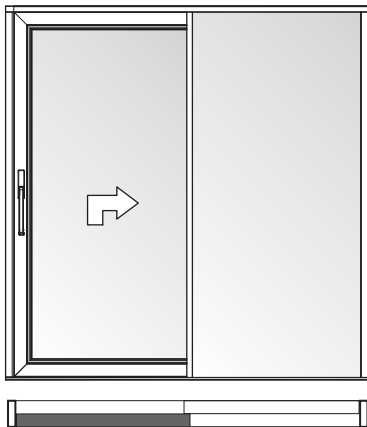

(Anta Mobile + Vetrata Fissa)

(Glazing Wall + Mobile Sash)

LISTA ACCESSORI | Accessories List

COMPLEMENTARI COMPLEMENTARIES	QT.	GUARNIZIONI GASKETS	QT.	KIT	QT.
LS 09	2H + 4L _{Anta}	AMX 10.05	=MX603.501	AHM 16.6745.68	1
ACX 10.81	=MX603.501	ARX 10.1X	=MX603.501	AHM 16.6745.72	1
AHX 6741.X	L _{Anta}	AHX 10.47	2L + 2L _{Anta}	AHM 16.6745.73	1
ACX 06.04	1pz./50cm	AHX 10.48	2H + 1L	AHM 16.6744.2*	1
ARX 43.SQ*	2 pz./Anta	AHX 10.63	L _{Anta}	AHM 16.6732.XX	1
ARX 10.SQ*		AHX 10.64	2H		
AHM 70.SQ	4 pz./Anta	ASX 10.69	8H + 2L		
ACX 50.SQ	2 pz./Anta	ACX 10.71	a pezzi		

*Opzionale

*Optional

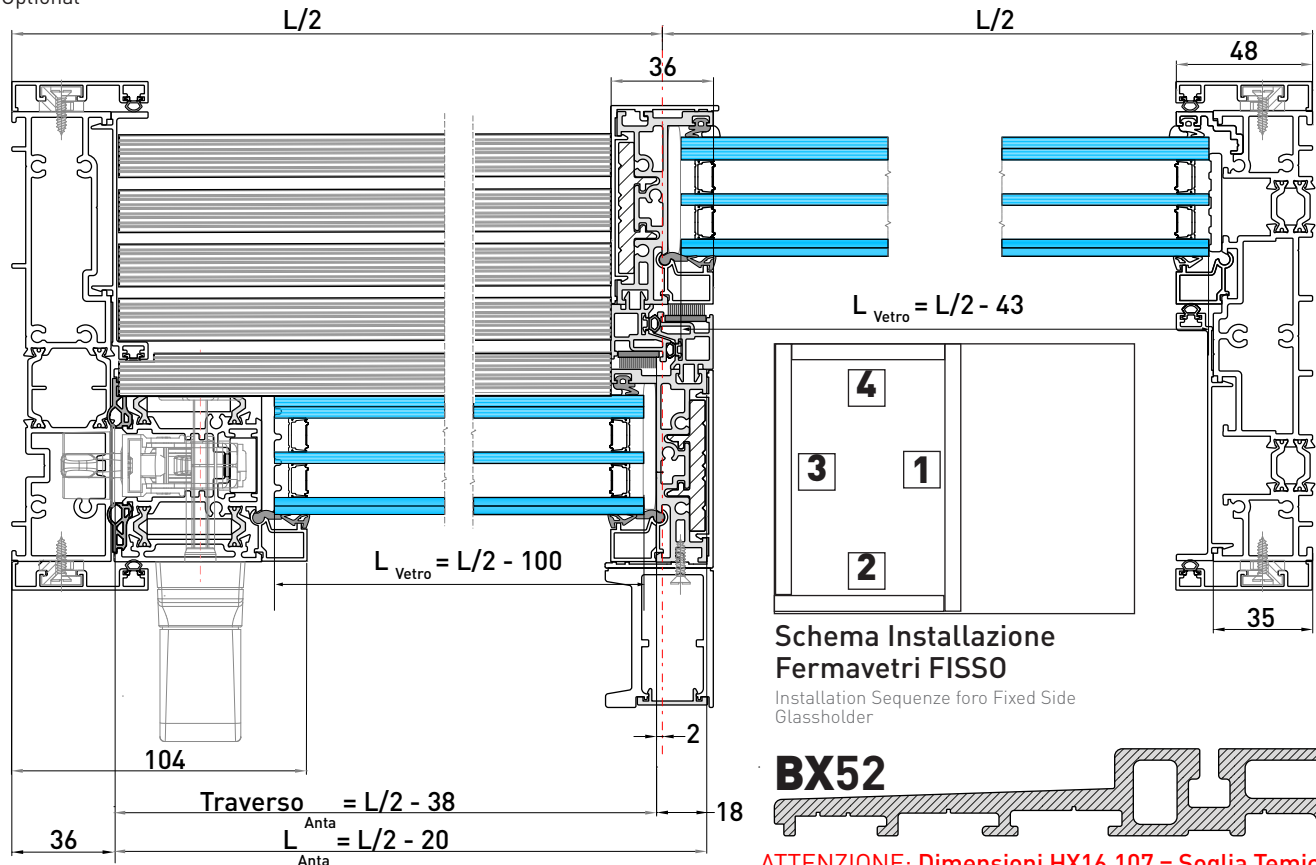
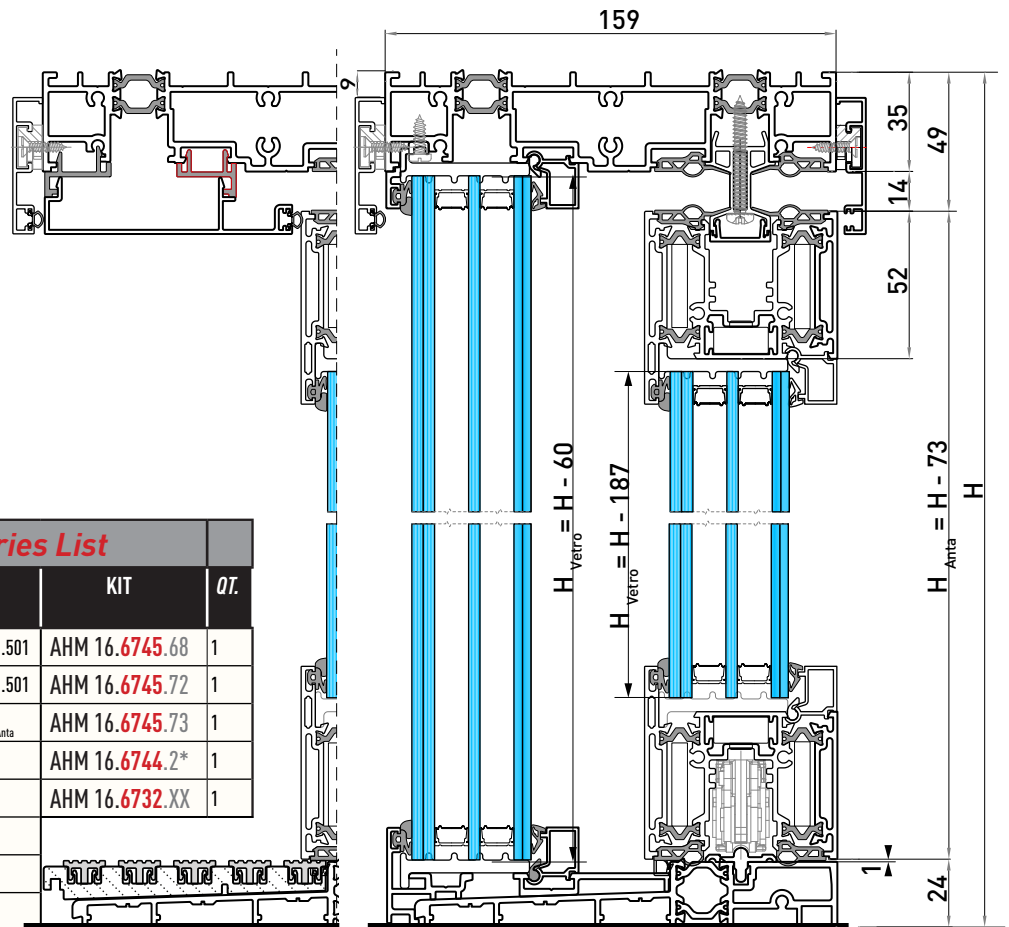

Schema Installazione
Fermavetri FISSO

Installation Sequenze foro Fixed Side
Glassholder

BX52

ATTENZIONE: Dimensioni HX16.107 = Soglia Termica BX52
PAY ATTENTION: Dimensions HX16.107 = BX52 Thermal Threshold

1 ANTA MOBILE + Vetrata Fissa - Versione 90°

1 SLIDING Sash + 1 FIX Glazing - 90° Version

Tipo A | A Type
(Anta Mobile + Anta Fissa)
 (Fixed Sash + Mobile Sash)

ART. Item	PROFILO Profile	DESCRIZIONE Description	DIM Size	TIPO TAGLIO Cut Type	QT
HM16.111		Telaio Traverso Superiore <i>Frame. Upper Transom</i>	L		1
		Telaio. Mont Lato Anta Mobile <i>Frame. Sliding Sash Side Mullion</i>	H - 68		1
HX16.105		Telaio. Mont Lato Vetrata Fissa <i>Frame. Fix Glazing Side Mullion</i>	H - 68		1
HX16.107 BX52		Soglia <i>Threshold</i>	L		1
HX16.169		Binario <i>Rail</i>	L - 72		1
HX16.504		Carter Coprifilo <i>Finishing Carter</i>	L		2
			H - 9		2 + 2
BX49		Guida Superiore <i>Upper Guide Rail</i>	L - 527		1
			325		1
BX48		Montante Centrale <i>Central Mullion</i>	H - 40		1
			H - 121		1
HM16.308		Profilo di Rinforzo <i>Reinforcement Profile</i>	H - 48		1
			H - 165		1
BX50		Labirinto Centrale <i>Central Labirinth</i>	H - 48		1
			H - 76		1
MX603.501		Fermavetro <i>Glass holder</i>	L/2 - 50		1
			L/2 - 66		1
			H - 51		1
			H - 67		1
			L/2 - 90		2
			H - 209		2
HM16.306		Cover Anta Centrale <i>Central Sash Cover</i>	H - 40		1
			H - 73		1
HM16.505		Fermavetro [Vetrata Fissa] <i>Glass Holder [Fix Glazing]</i>	L/2 - 53		1
			H - 83		1
HM16.304		Trascinamento Anta [OPZ.] <i>Sash Driver Profile [OPT.*]</i>	H - 99		1
XX70.704		Finitura HM16.304 [OPZ.] <i>HM16.304 Finishing [OPT.]</i>	H - 99		1
ASX10.26		Finitura BX49 <i>BX49 Finishing</i>	L - 527		1
			325		1
			130		1
HM16.507		Fermavetro Interno Vetrata <i>Glazing Internal Glass Holder</i>	L/2 - 53		1
HM16.506		Fermavetro Esterno Vetrata <i>Glazing External Glass Holder</i>	L/2 - 53		1
HM16.204		Anta <i>Sash</i>	L/2 - 38		1
			L/2 - 38		1
			H - 73		1
HM16.508		Telaio. CarterMontante <i>Frame. Mullion Carter</i>	H - 54		1
			H - 57		1
HX16.503		Telaio. Carter Traverso Superiore <i>Frame. Upper Transom Carter</i>	L/2 - 53		1
HM16.512		**			
XX16.102		Drenaggio Soglia <i>Drainage for Threshold</i>	L/2 - 56		5
AHM16.01		Supporto Per Drenaggio Soglia <i>Threshold Drainage Support</i>			6pz./m

ATTENZIONE : Le dimensioni dei vetri non sono uguali, è stata data priorità alla simmetria del montante centrale.
PAY ATTENTION : Dimensions Glass panels are differnt; the central mullion symmetry has been prioritized.
**** Variante al profilo HX16.503. Con questa Variante NON SI UTILIZZA l'accessorio AHM16.6745.72**
****Version of profile HX16.503. With this profile is NOT USED accessory AHM16.6745.72**

Tipo B | B Type

2 ANTE SCORREVOLI - Versione 90°

2 SLIDING Sashes - 90° Version

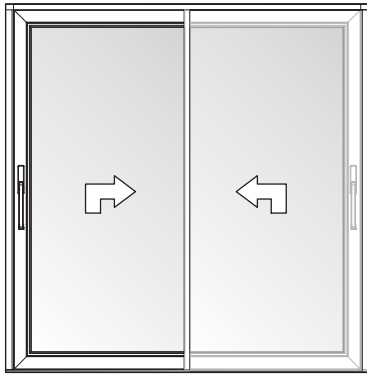

(Anta Mobile + Anta Mobile)
(Sliding Sash + Sliding Sash)

LISTA ACCESSORI Accessories List					
COMPLEMENTARI COMPLEMENTARIES	QT.	GUARNIZIONI GASKETS	QT.	KIT	QT.
LS 09	4H + 8L _{Anta}	AMX 10.05	=MX603.501	AHM 16.6745.69	1
ACX 10.81	=MX603.501	ARX 10.1X	=MX603.501	AHM 16.6745.73	1
AHX 6741.X	2L _{Anta}	AHX 10.47	4L+4L _{Anta}	AHM 16.6744.2*	2
ACX 06.04	1pz./50cm	AHX 10.48	4H + 2L _{Anta}	AHM 16.6732.XX	2
ARX 43.SQ*	2 pz./Anta	AHX 10.63	2L _{Anta}		
ARX 10.SQ*	2 pz./Anta	AHX 10.64	2H		
AHM 70.SQ	4 pz./Anta	ASX 10.69	8H + 2L		
ACX 50.SQ	2 pz./Anta	ACX 10.71	a pezzi		

*Opzionale
*Optional

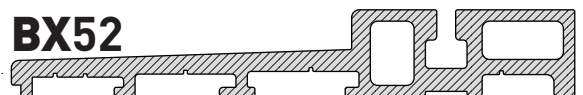
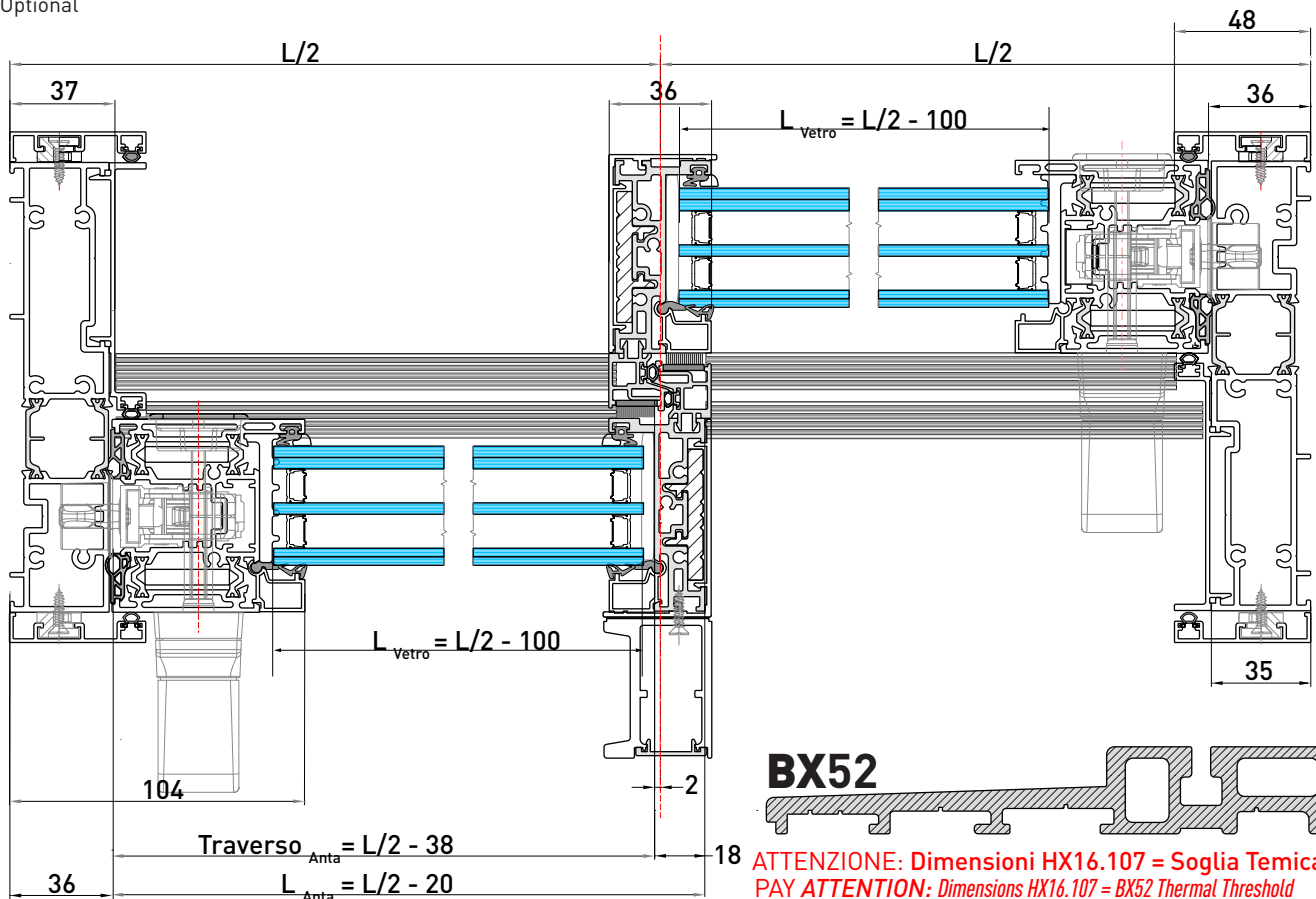
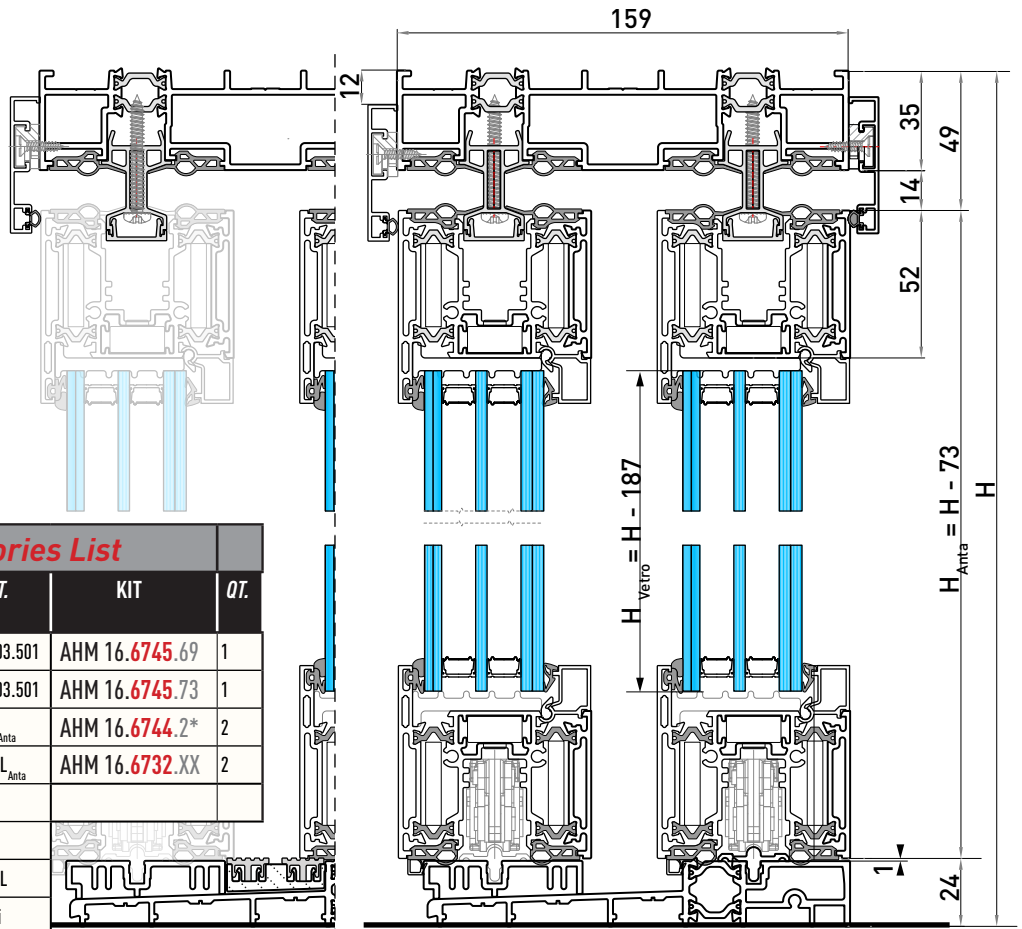

BX52
ATTENZIONE: Dimensioni HX16.107 = Soglia Termica BX52
PAY ATTENTION: Dimensions HX16.107 = BX52 Thermal Threshold

SCORREVOLE A 2 ANTE - Versione 90°

SLIDING Sash WITH 2 SashS - 90° Version

Tipo B | B Type
(Anta Mobile + Anta mobile)
 (Fixed Sash + Mobile Sash)

ART. Item	PROFILO Profile	DESCRIZIONE Description	DIM Size	TIPO TAGLIO Cut Type	QT
HM16.106		Telaio Traverso Superiore <i>Frame. Upper Transom</i>	L		1
HX16.105		Telaio. Montanti DX e SX <i>Frame. RX and LX Side Mullion</i>	H - 68		2
HX16.107 BX52		Soglia <i>Threshold</i>	L		1
HX16.169		Binario <i>Rail</i>	L - 72		2
HX16.171		Sottobinario <i>Rail Support</i>	L - 72		1
HX16.504		Carter Copifilo <i>Finishing Carter</i>	L		2
			H - 12		2 + 2
BX49		Guida Superiore <i>Upper Guide Rail</i>	L - 527		2
			325		2
BX48		Montante Centrale <i>Central Mullion</i>	H - 121		2
HM16.308		Profilo di Rinforzo <i>Reinforcement Profile</i>	H - 165		2
BX50		Labirinto Centrale <i>Central Labyrinth</i>	H - 76		2
MX603.501		Fermavetro <i>Glass holder</i>	L/2 - 90		4
			H - 209		4
HM16.306		Cover Anta Centrale <i>Central Sash Cover</i>	H - 73		2
HM16.304		Trascinamento Anta [OPZ.] <i>Sash Driver Profile [OPT.]</i>	H - 99		2
XX70.704		Finitura HM16.304 [OPZ.] <i>HM16.304 Finishing [OPT.]</i>	H - 99		2
ASX10.26		Finitura BX49 <i>BX49 Finishing</i>	L - 527		2
			325		2
			130		2
HM16.204		Anta <i>Sash</i>	L/2 - 38		2
			L/2 - 38		2
			H - 73		2
HM16.508		Telaio. CarterMontante <i>Frame. Mullion Carter</i>	H - 54		1
			H - 35		1
XX16.102		Drenaggio Soglia <i>Drainage for Threshold</i>	L/2 - 57,5		3
			L/2 - 68		1
AHM16.01		Supporto Per Drenaggio Soglia <i>Threshold Drainage Support</i>			6pz./m

2 ANTE SCORREVOLI - Versione 45°

2 SLIDING Sashes - 45° Version

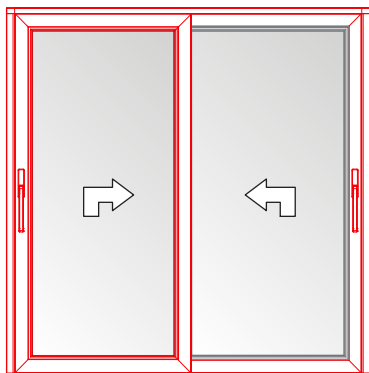

(Anta Mobile + Anta Mobile)

(Sliding Sash + Sliding Sash)

LISTA ACCESSORI | Accessories List

COMPLEMENTARI COMPLEMENTARIES	QT. QTY.	GUARNIZIONI GASKETS	QT. QTY.	KIT	QT. QTY.
LS 09	8H + 8L _{Anta}	AMX 10.05	=MX603.501	AHM 16.6745.70	1
ACX 10.81	=MX603.501	ARX 10.1X	=MX603.501	AHM 16.6744.2*	2
AHX 6741.X	2L _{Anta}	AHX 10.47	4L + 4L _{Anta}	AHM 16.6732.XX	2
ACX 06.04	1pz./50cm	AHX 10.48	4h + 2L _{Anta}		
ARX 43.SQ*	4 pz./Anta	AHX 10.63	2L _{Anta}		
ARX 10.SQ*		AHM 10.65	2H		
AHM 70.SQ	8 pz./Anta	ASX 10.69	8H + 2L		
ACX 50.SQ	4 pz./Anta	ACX 10.71	a pezzi		

*Opzionale

*Optional

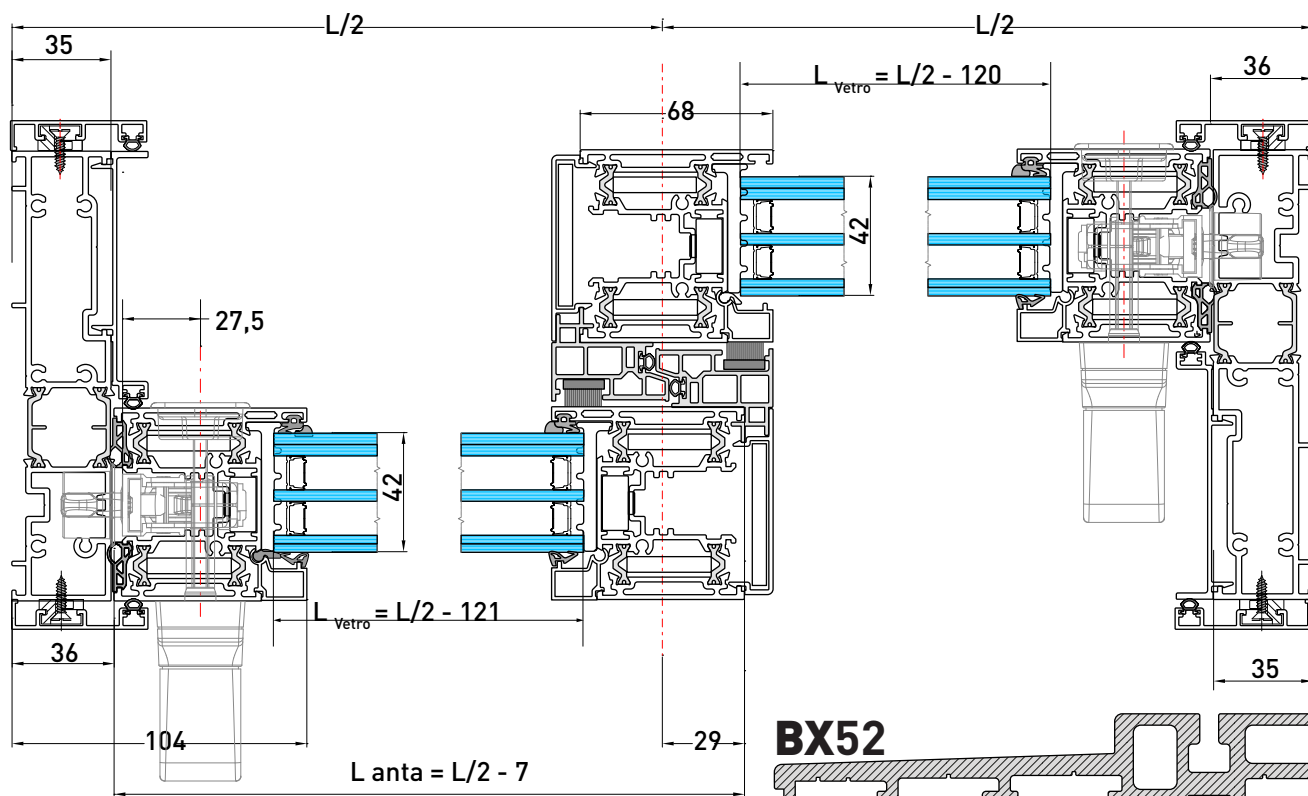
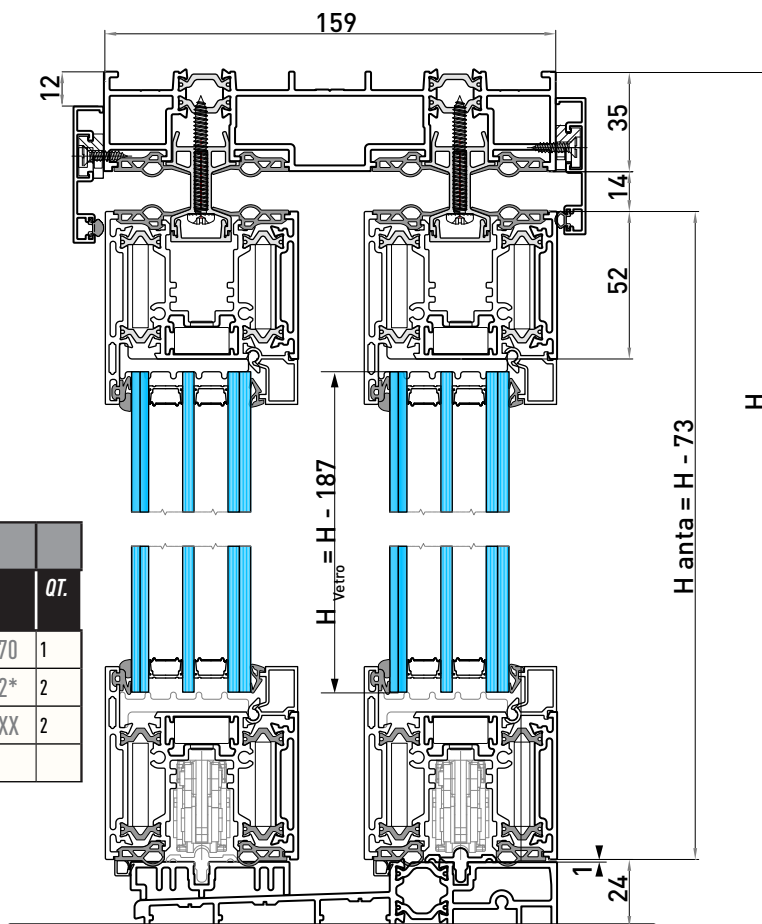

ATTENZIONE: Dimensioni HX16.107 = Soglia Termica BX52
PAY ATTENTION: Dimensions HX16.107 = BX52 Thermal Threshold

SCORREVOLE A 2 ANTE - Versione 45°

SLIDING Sash WITH 2 SashS - 45° Version

Tipo C | C Type
(Anta Mobile + Anta mobile)
 (Fixed Sash + Mobile Sash)

ART. Item	PROFILO Profile	DESCRIZIONE Description	DIM Size	TIPO TAGLIO Cut Type	QT
HM16.106		Telaio Traverso Superiore <i>Frame. Upper Transom</i>	L		1
HX16.105		Telaio. Montanti DX e SX <i>Frame. RX and LX Side Mullion</i>	H - 68		2
HX16.107 BX52		Soglia <i>Threshold</i>	L		1
HX16.169		Binario <i>Rail</i>	L - 72		2
HX16.171		Sottobinario <i>Rail Support</i>	L - 72		1
HX16.504		Carter Coprifilo <i>Finishin Carter</i>	L		2
			H - 12		2
BX49		Guida Superiore <i>Upper Guide Rail</i>	L - 527 325		2 2
BX51		Labirinto Centrale <i>Central Labirinth</i>	H - 76		2
HM16.307		Cover Anta Centrale <i>Central Sash Cover</i>	H - 121		2
MX603.501		Fermavetro <i>Glass holder</i>	L/2 - 111		4
			H - 209		4
HM16.304		Trascinamento Anta [OPZ.*] <i>Sash Driver Profile [OPT.*]</i>	H - 99*		2
XX70.704		Finitura HM16.304 [OPZ.*] <i>HM16.304 Finishing [OPT.*]</i>	H - 99*		2
ASX10.26		Finitura BX49 <i>BX49 Finishing</i>	L - 527		2
			325		2
			130		2
HM16.204		Anta <i>Sash</i>	L/2 - 7		4
			H - 73		4
HM16.508		Telaio. CarterMontante <i>Frame. Mullion Carter</i>	H - 48		1
			H - 35		1
XX16.102		Drenaggio Soglia <i>Drainage for Threshold</i>	L/2 - 77		3
			L/2 - 88		1
AHM16.01		Supporto Per Drenaggio Soglia <i>Threshold Drainage Support</i>			6pz./m



Tipo C | C Type

4 ANTE - Versione 90°

4 Sashes - 90° Version

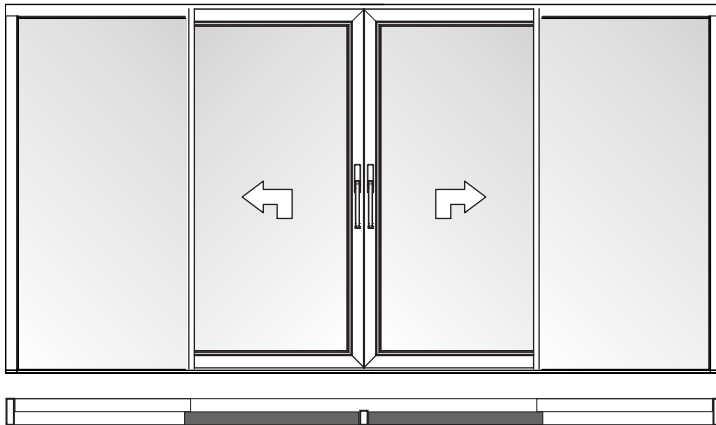

(2 Vetrate Fisse EXT + 2 Ante Scorrevoli INT)

(2 Fixed EXT Sashes + 2 Sliding INT Sashes)

LISTA ACCESSORI Accessories List					
COMPLEMENTARI COMPLEMENTARIES	QT.	GUARNIZIONI GASKETS	QT.	KIT	QT.
LS 09	4H + 8L _{Anta}	AMX 10.05	=MX603.501	AHM 16.6745.68	2
ACX 10.81	=MX603.501	ARX 10.1X	=MX603.501	AHM 16.6745.71	1
AHX 6741.X	2L _{Anta}	AHX 10.47	2L + 4L _{Anta}	AHM 16.6745.72	2
ACX 06.04	1pz./50cm	AHX 10.48	4H + 2L _{Anta}	AHM 16.6745.73	2
ARX 43.SQ*	2 pz./Anta	AHX 10.63	2L _{Anta}	AHM 16.6744.2*	2
ARX 10.SQ*	2 pz./Anta	AHX 10.64	4H	AHM 16.6730.XX	1
AHM 70.SQ	4 pz./Anta	ASX 10.69	12H + 2L		
ACX 50.SQ	2 pz./Anta	ACX 10.71	a pezzi		

*Opzionale
*Optional

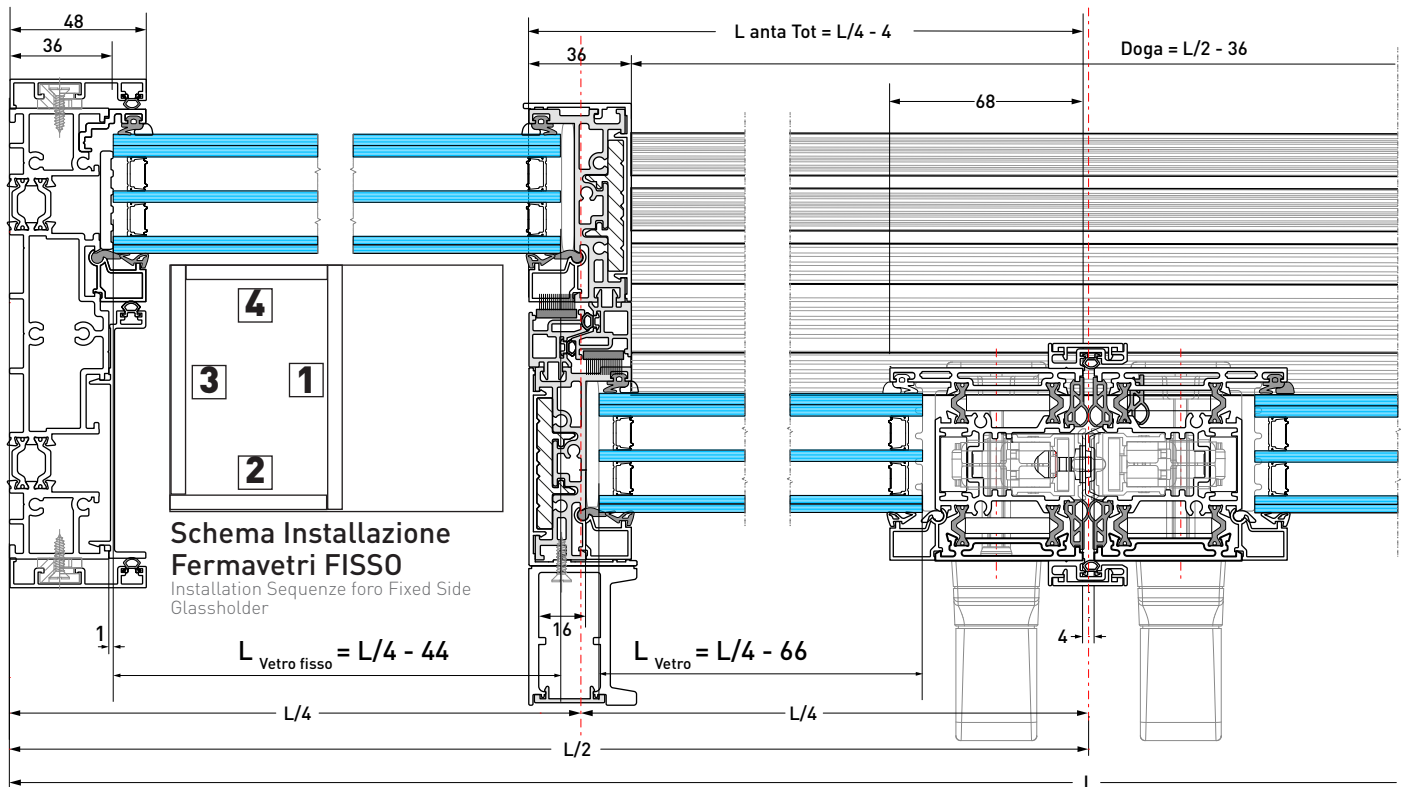
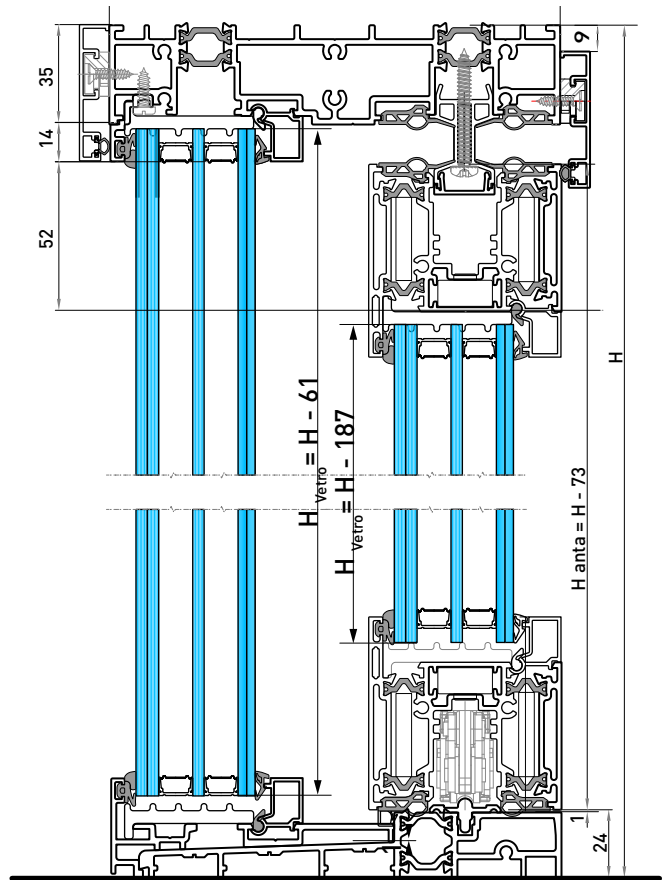

ATTENZIONE: Dimensioni HX16.107 = Soglia Temica BX52
PAY ATTENTION: Dimensions HX16.107 = BX52 Thermal Threshold

**SCORREVOLE A 2 ANTE + 2 Vetrate Fisse -
Versione 90°**

SLIDING Sash WITH 2 Sliding Sashes + 2 Fix GLAZING - 90° Version

Tipo D | D Type
(2 Fissi EXT + 2 Ante mobili INT)
 (2 Fixed EXT Sashes + 2 Mobile INT Sashes)

ART. Item	PROFILO Profile	DESCRIZIONE Description	DIM Size	TIPO TAGLIO Cut Type	QT
HM16.111		Telaio Trasverso Superiore <i>Frame. Upper Transom</i>	L		1
		Telaio. Mont Lato Vetrata Fissa <i>Frame. Fix Glazing Side Mullion</i>	H - 68		2
HX16.107 BX52		Soglia <i>Threshold</i>	L		1
HX16.169		Binario <i>Rail</i>	L - 74		1
HX16.504		Carter Copifilo <i>Finishing Carter</i>	L		2
			H		2
			H - 9		2
BX49		Guida Superiore <i>Upper Guidede Rail</i>	L - 984 325		1 2
BX48		Montante Centrale <i>Central Mullion</i>	H - 40		2
			H - 121		2
HM16.308		Profilo di Rinforzo <i>Reinforcement Profile</i>	H - 48		2
			H - 165		2
BX50		Labirinto Centrale <i>Central Labirinth</i>	H - 48		2
			H - 76		2
MX603.501		Fermavetro <i>Glass holder</i>	L/4 - 56		2
			H - 209		2
			L/4 - 50		2
			L/4 - 66		2
			H - 51		2
HM16.306		Cover Anta Centrale <i>Central Sash Cover</i>	H - 40		2
			H - 73		2
HM16.505		Fermavetro [Vetrata Fissa] <i>Glass Holder [Fix Glazing]</i>	L/4 - 53		2
			H - 83		2
HM16.304		Trascinamento Anta [OPZ.] <i>Sash Driver Profile [OPT.*]</i>	H - 99		2
XX70.704		Finitura HM16.304 [OPZ.] <i>HM16.304 Finishing [OPT.]</i>	H - 99		2
		Finitura HM16.511 <i>HM16.511 Finishing</i>	H - 95		2
HM16.511		Cover incontro 4 Anta <i>Cover joint 4 sash</i>	H - 95		2
ASX10.26		Finitura BX49 <i>BX49 Finishing</i>	L - 984		1
			325		2
			130		2
HM16.507		Fermavetro Interno Vetrata <i>Glazing Internal Glass Holder</i>	L/4 - 53		2
HM16.506		Fermavetro Esterno Vetrata <i>Glazing External Glass Holder</i>	L/4 - 53		2
HM16.204		Anta <i>Sash</i>	L/4 - 4		2
			L/4 - 4		2
			H - 73		2
HM16.508	**	Telaio. Carter Montante <i>Frame. Mullion Carter</i>	H - 54		2
HX16.503		Telaio. Carter Trasverso Superiore <i>Frame. Upper Transom Carter</i>	L/2 - 36		1
HM16.512					
XX16.102		Drenaggio Soglia <i>Drainage for Threshold</i>	L/2 - 36		5
AHM16.01		Supporto Per Drenaggio Soglia <i>Threshold Drainage Support</i>			6pz./m

**** Variante al profilo HX16.503. Con questa Variante NON SI UTILIZZA l'accessorio AHM16.6745.72**
****Version of profile HX16.503. With this profile is NOT USED accessory AHM16.6745.72**

Tipo E | E Type

SCORREVOLE Angolo 4 ANTE - Versione 45°

4 Sashes Corner SLIDING Window - 45° Version

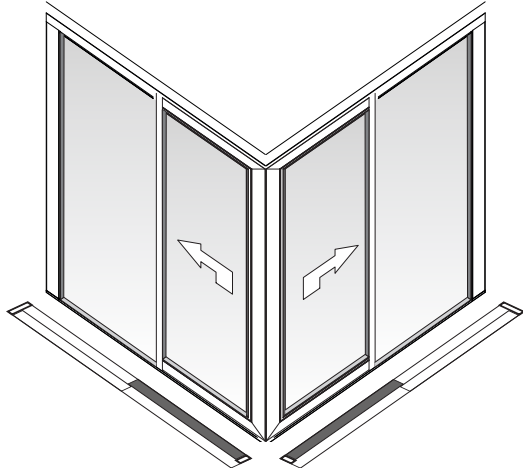

(2 Vetrare Fisse EXT + 2 Ante mobili INT)

(2 Fixed EXT Sashes + 2 Mobile INT Sashes)

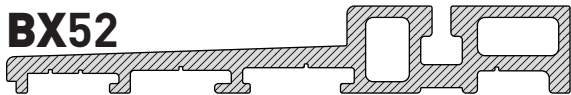

ATTENZIONE: Dimensioni HX16.107 = Soglia Temica BX52
PAY ATTENTION: Dimensions HX16.107 = BX52 Thermal Threshold

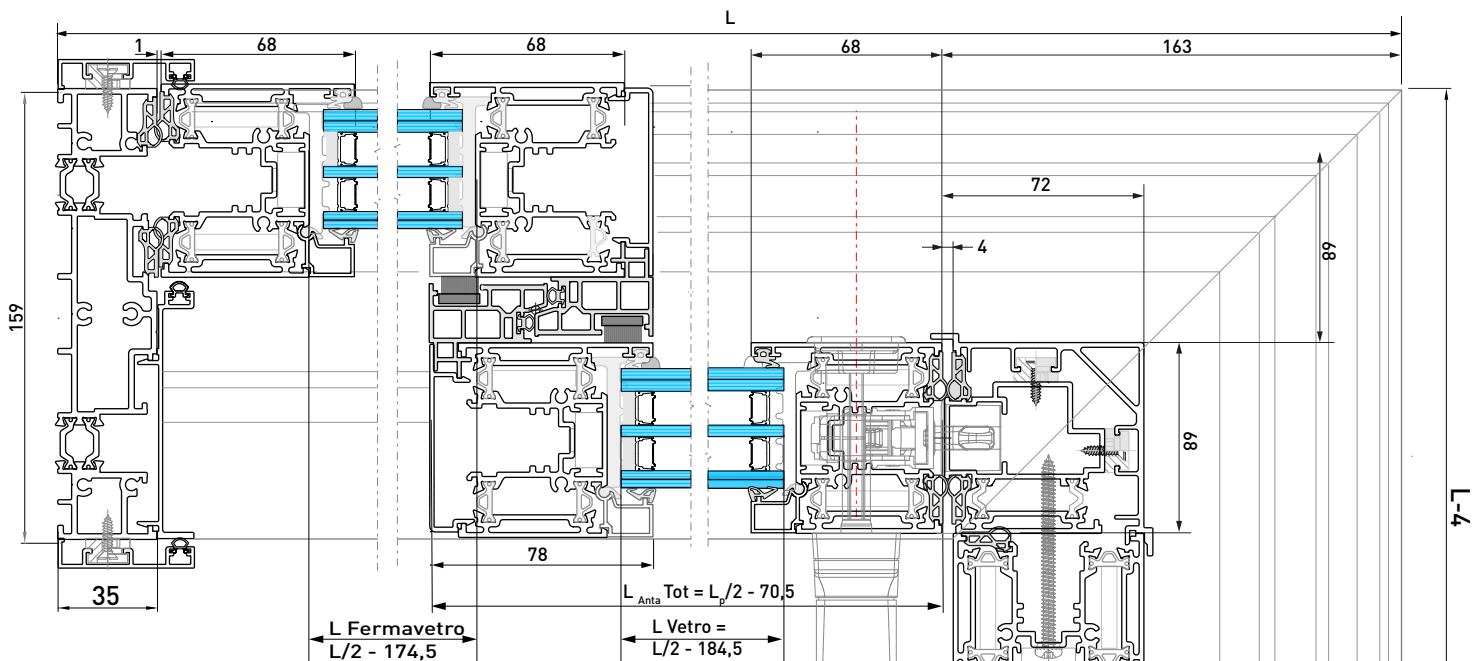
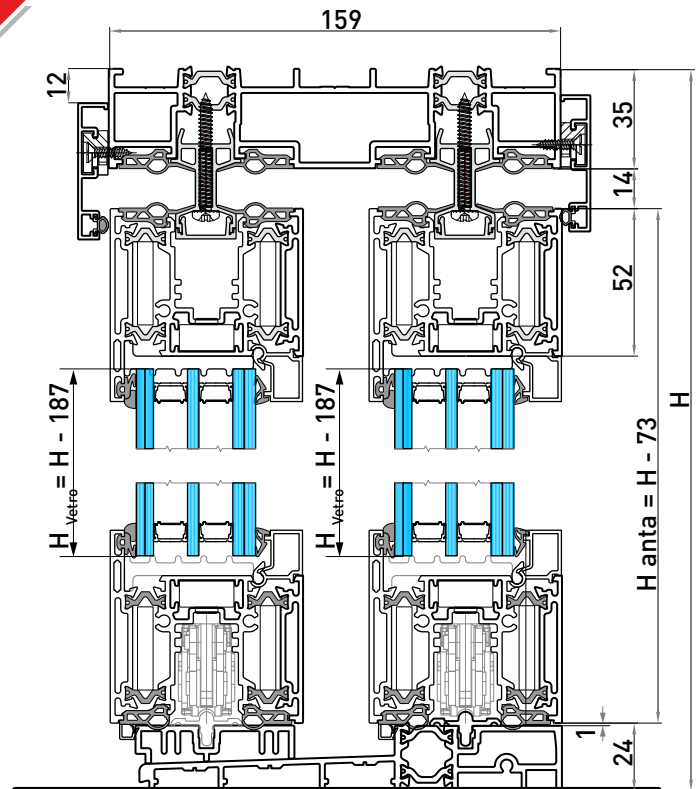

LISTA ACCESSORI | Accessories List

COMPLEMENTARI COMPLEMENTARIES	QT.	GUARNIZIONI GASKETS	QT.	KIT	QT.
LS 09	16H + 16L _{Anta}	AMX 10.05	=MX603.501	AHM 16.6745.76	2
ACX 10.81	=MX603.501	ARX 10.1X	=MX603.501	AHM 16.6745.74	1
AHX 6741.X	2L _{Anta}	AHX 10.47	8L + 8L _{Anta}	AHM 16.6745.72	2
ACX 06.04	1pz./50cm	AHX 10.48	10H + 4L _{Anta}	AHM 16.6744.2*	2
ARX 43.SQ*	4 pz./Anta	AHX 10.63	4L _{Anta}	AHM 16.6732.XX	1
ARX 10.SQ*		AHX 10.64	4H		
AHM 70.SQ	8 pz./Anta	ASX 10.69	10H + 4L		
ACX 50.SQ	4 pz./Anta	ACX 10.71	a pezzi		

*Opzionale
*Optional

SCORREVOLE Angolo 4 ANTE - Versione 90°

SLIDING Sash WITH 4 Sashes - 90° Version

Tipo E | E Type
(2 Ante Fisse EXT + 2 Ante mobili INT)

(2 Fixed EXT Sashes + 2 Mobile INT Sashes)

ART. Item	PROFILO Profile	DESCRIZIONE Description	DIM Size	TIPO TAGLIO Cut Type	QT
HM16.111		Telaio Trasverso Superiore <i>Frame. Upper Transom</i>	L L - 4		1 1
		Telaio. Mont Lato Vetrata Fissa <i>Frame. Fix Glazing Side Mullion</i>	H - 68		2
HX16.107 BX52		Soglia <i>Threshold</i>	L - 10 L - 14		1 1
HX16.169		Binario <i>Rail</i>	L - 149,5 L - 153,5		1
HX16.171		Sottobinario <i>Rail Support</i>	L/2 - 105,8		1
HX16.504		Carter Coprifilo <i>Finishing Carter</i>	L + 10,5		1
			L + 6,5		1
			L - 163		1
			L - 167		1
			H - 12		4
BX49		Guida Superiore <i>Upper Guided Rail</i>	L - 605		1
			L - 609		1
			325		2
			L - 150		1
			(L - 154)		1
BX51		Labirinto Centrale <i>Central Labirinth</i>	H - 76		4
MX603.501		Fermavetro <i>Glass holder</i>	L/2 - 174,5		4
			L/2 - 178,5		4
			H - 209		8
HM16.304		Trascinamento Anta [OPZ.*] <i>Sash Driver Profile [OPT.*]</i>	H - 99*		4
XX70.704		Finitura HM16.304 [OPZ.*] <i>HM16.304 Finishing [OPT.*]</i>	H - 99*		4
ASX10.26		Finitura BX49 <i>BX49 Finishing</i>	L - 605		1
			L - 609		1
			325		2
			130		2
			L - 150		1
			L - 154		1
HM16.204		Anta <i>Sash</i>	L/2 - 70,5		4
			L/2 - 70,5		4
			H - 73		8
HM16.307		Cover Anta Centrale <i>Central Sash Cover</i>	H - 121		4
HM16.508		Telaio. Carter Montante <i>Frame. Mullion Carter</i>	H - 48		2
HX16.503		Telaio. Carter Trasverso Superiore <i>Frame. Upper Transom Carter</i>	L/2 - 24,5		1
HM16.512			L/2 - 28,5		1
HM16.509		Montante D'Angolo <i>Corner Mullion</i>	H - 107,5		1
HM16.510		Carter Montante Angolo <i>Cornel Mullion Carter</i>	H - 77		1

**** Variante al profilo HX16.503. Con questa Variante NON SI UTILIZZA l'accessorio AHM16.6745.72**

**/Version of profile HX16.503. With this profile is NOT USED accessory AHM16.6745.72

1 ANTA MOBILE - Versione 45°

1 SLIDING Sash - 45° Version

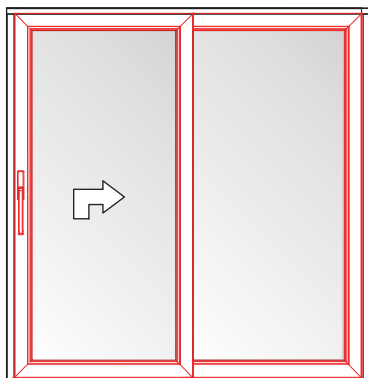

(Anta Mobile + Anta Fissa)

(Sliding Sash + Fixed Sash)

LISTA ACCESSORI | Accessories List

COMPLEMENTARI COMPLEMENTARIES	QT.	GUARNIZIONI GASKETS	QT.	KIT	QT.
LS 09	8H + 8L _{Anta}	AMX 10.05	=MX603.501	AHM 16.6745.76	1
ACX 10.81	=MX603.501	ARX 10.1X	=MX603.501	AHM 16.6744.2*	2
AHX 6741.X	2L _{Anta}	AHX 10.47	4L + 4L _{Anta}	AHM 16.6732.XX	2
ACX 06.04	1pz./50cm	AHX 10.48	4h + 2L _{Anta}		
ARX 43.SQ*	4 pz./Anta	AHX 10.63	2L _{Anta}		
ARX 10.SQ*	4 pz./Anta	AHM 10.65	2H		
AHM 70.SQ	8 pz./Anta	ASX 10.69	8H + 2L		
ACX 50.SQ	4 pz./Anta	ACX 10.71	a pezzi		

*Opzionale
*Optional

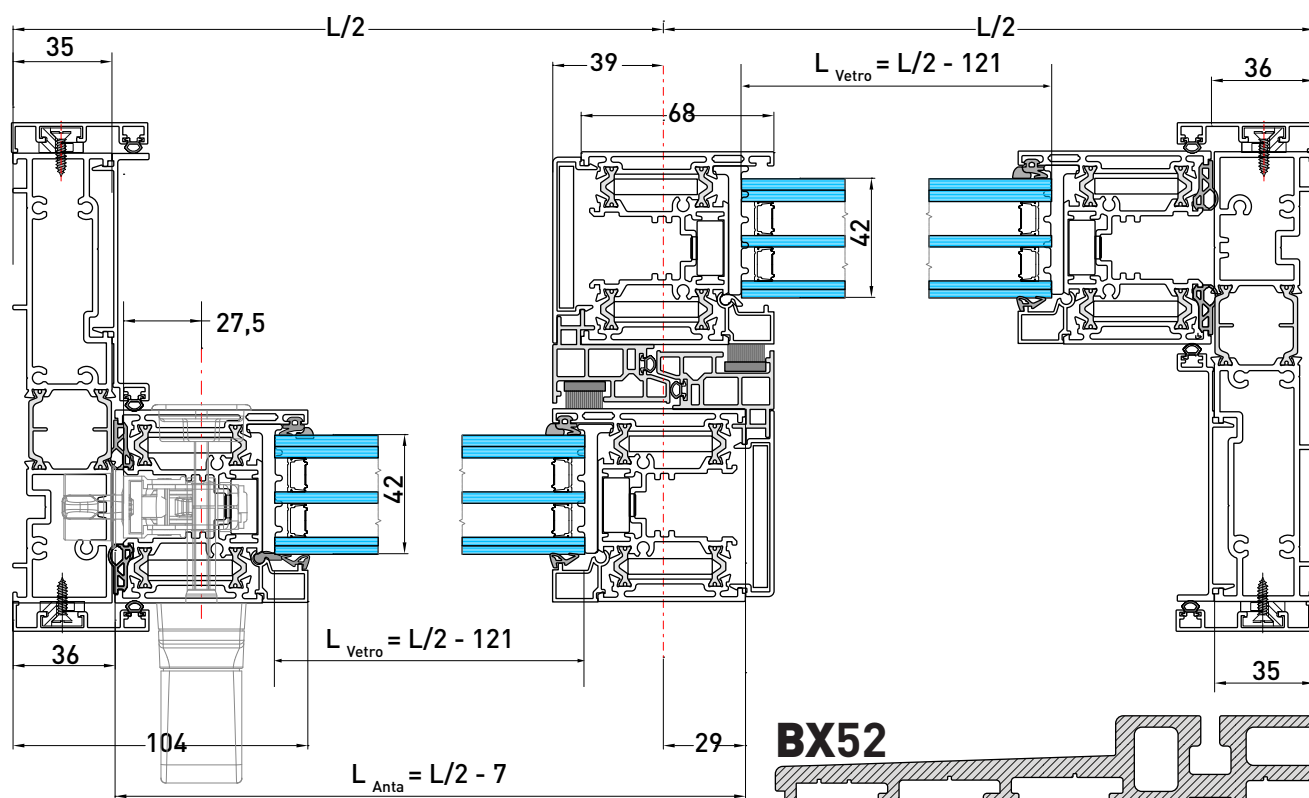
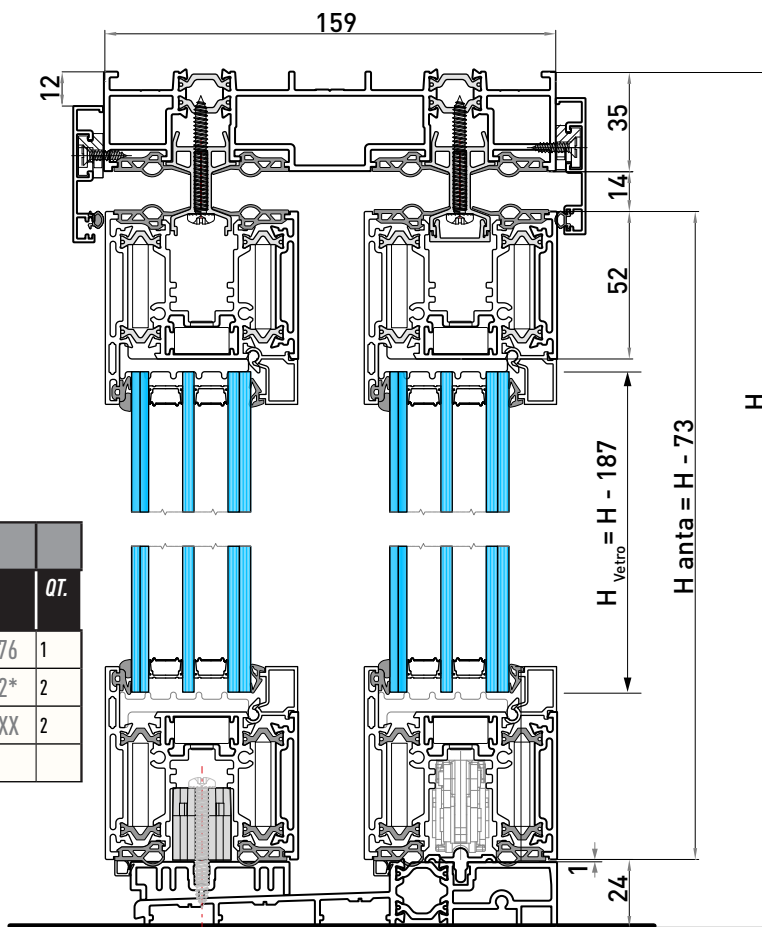

ATTENZIONE: Dimensioni HX16.107 = Soglia Termica BX52
PAY ATTENTION: Dimensions HX16.107 = BX52 Thermal Threshold

SCORREVOLE A 2 ANTE - Versione 45°

SLIDING Sash WITH 2 SashS - 45° Version

Tipo C | C Type
(Anta Fissa + Anta mobile)
 (Fixed Sash + Mobile Sash)

ART. Item	PROFILO Profile	DESCRIZIONE Description	DIM Size	TIPO TAGLIO Cut Type	QT
HM16.106		Telaio Trasverso Superiore <i>Frame. Upper Transom</i>	L		1
HX16.105		Telaio. Montanti DX e SX <i>Frame. RX and LX Side Mullion</i>	H - 68		2
HX16.107 BX52		Soglia <i>Threshold</i>	L		1
HX16.169		Binario <i>Rail</i>	L - 72		1
HX16.171		Sottobinario <i>Rail Support</i>	L/2 - 90,8		1
HX16.504		Carter Coprifilo <i>Finishin Carter</i>	L		2
			H - 12		2 + 2
BX49		Guida Superiore <i>Upper Guide Rail</i>	L - 527		1
			325		1
			L/2		1
BX51		Labirinto Centrale <i>Central Labyrinth</i>	H - 76	Mobile 	2
MX603.501		Fermavetro <i>Glass holder</i>	L/2 - 111	Mobile 	2
			H - 209	Mobile 	2
HM16.304		Trascinamento Anta [OPZ.] <i>Sash Driver Profile [OPT.*]</i>	H - 99	Mobile 	1
XX70.704		Finitura HM16.304 [OPZ.] <i>HM16.304 Finishing [OPT.*]</i>	H - 99	Mobile 	1
ASX10.26		Finitura BX49 <i>BX49 Finishing</i>	L - 527		1
			325		1
			130		1
			L/2		1
HM16.204		Anta <i>Sash</i>	L/2 - 7		4
			H - 73		4
HM16.307		Cover Anta Centrale <i>Central Sash Cover</i>	H - 121		2
HM16.512		Telaio. Carter Trasverso Superiore <i>Frame. Upper Transom Carter</i>	L /2 - 74	Esterno External 	1
HM16.508		Telaio. CarterMontante <i>Frame. Mullion Carter</i>	H - 54	Interno Internal 	1
			H - 57	Esterno External 	1

2 ANTE SCORREVOLI - Versione LEGNO45°

2 SLIDING Sashes - WOOD 45° Version

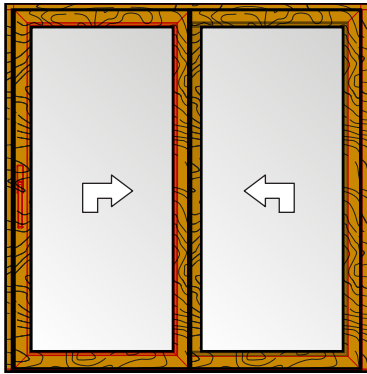

(Anta Mobile + Anta Mobile)
(Sliding Sash + Sliding Sash)

LISTA ACCESSORI Accessories List					
COMPLEMENTARI COMPLEMENTARIES	QT.	GUARNIZIONI GASKETS	QT.	KIT	QT.
AWX 06.04	L _{Anta} / 50 cm	AWX 10.20	2H	AHM 16.6745.70	1
LS 09	8H + 8L _{Anta}	AWX 10.21	4H + 4L _{Anta}	AHM 16.6744.2*	1
ACX 10.82	=MX603.501	AWX 10.36	4H + 4L _{Anta}	AHM 16.6732.XX	1
AHX 6741.X	2L _{Anta}	AHX 10.47	4L + 4L _{Anta}		
ACX 06.04	1pz./50cm	AHX 10.48	4H + 2L _{Anta}		
ARX 43.SQ*	4 pz./Anta	AHX 10.63	2L _{Anta}	*Opzionale *Optional	
ARX 10.SQ*		AHM 10.65	2H		
AHM 70.SQ	4 pz./Anta	ASX 10.69	4H + 2L		
ACX 50.SQ	4 pz./Anta	AMX 10.05	4H + 4L _{Anta}		

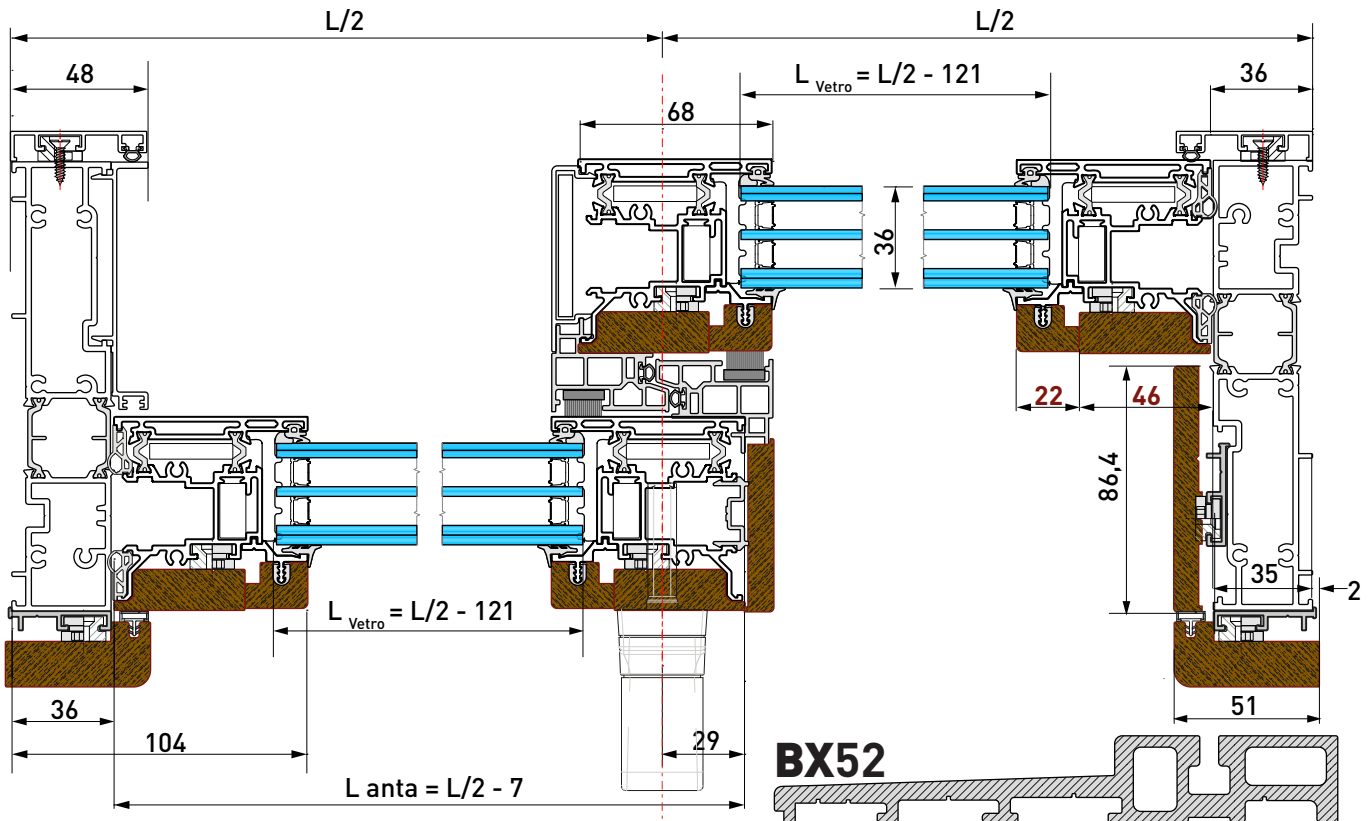
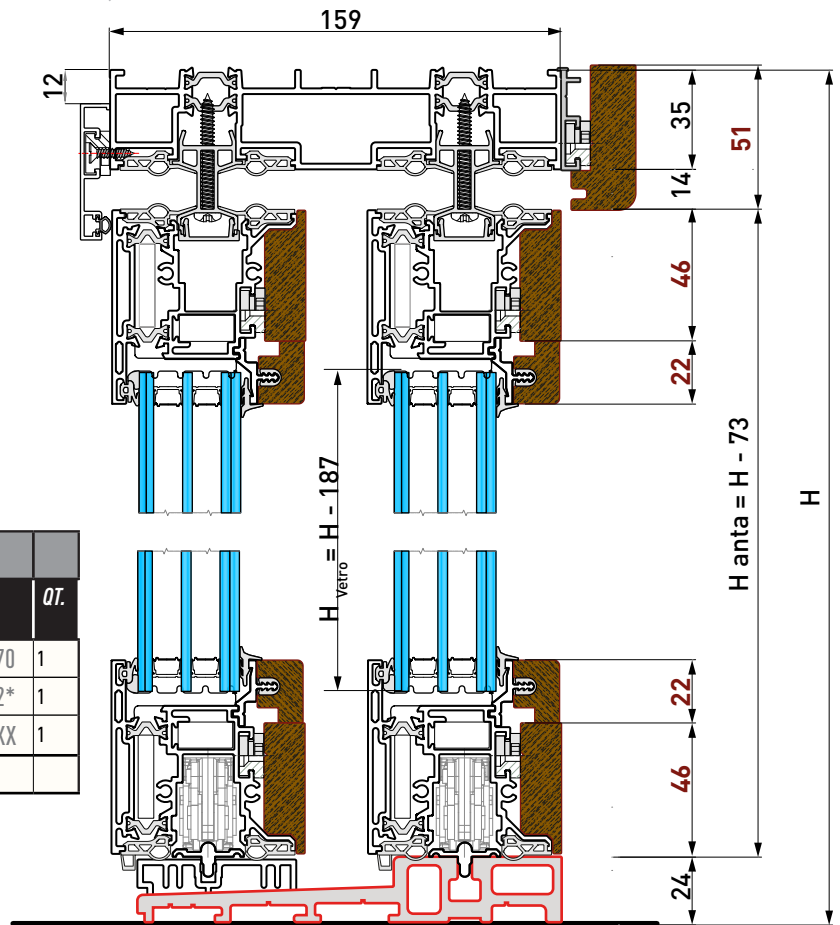

BX52

ATTENZIONE: Dimensioni HX16.107 = Soglia Termica BX52
PAY ATTENTION: Dimensions HX16.107 = BX52 Thermal Threshold

SCORREVOLE A 2 ANTE - Versione LEGNO45°

SLIDING Sash WITH 2 SashS - WOOD 45° Version

Tipo C | C Type
(Anta Mobile + Anta mobile)
 (Fixed Sash + Mobile Sash)

ART. Item	PROFILO Profile	DESCRIZIONE Description	DIM Size	TIPO TAGLIO Cut Type	QT
HM16.106		Telaio Traverso Superiore Frame. Upper Transom	L		1
HX16.105		Telaio. Montanti DX e SX Frame. RX and LX Side Mullion	H - 68		2
HX16.107 BX52		Soglia Threshold	L		1
HX16.169		Binario Rail	L - 84 L - 72		1 1
HX16.171		Sottobinario Rail Support	L - 72		1
HX16.504		Carter Coprifilo Finisher Carter	L		1
			H - 12		2
BX49		Guida Superiore Upper Guide Rail	L - 527		1
			325		2
			L - 539		1
BX51		Labirinto Centrale Central Labyrinth	H - 76		2
HM16.304		Trascinamento Anta [OPZ.*] Sash Driver Profile [OPT.*]	H - 99*		2
XX70.704		Finitura HM16.304 [OPZ.*] HM16.304 Finishing [OPT.*]	H - 99*		2
ASX10.26		Finitura BX49 BX49 Finishing	L - 527		1
			325		2
			130		2
			L - 539		1
HM18.205		Anta Sash	L/2 - 7		4
			H - 73		4
HM16.307		Supporto Fermavetro HW-E HW-E Glass Holder Support	L/2 - 101 H - 213		4 4
HM16.307		Cover Anta Centrale Central Sash Cover	H - 121		1
HM16.508		Telaio. Carter Montante Esterno Frame. External Mullion Carter	H - 35		1
HW18.304		Adattatore fissaggio legno Anta Wood fixing adapter for SASH	100mm		pz./400 mm
DW86.101		Adattatore fissaggio legno Telaio Wood fixing adapter for FRAME	L		1
			H		1
DW-A		Coprifilo INTERNO Telaio Main Frame INTERNAL Finishing	L + 4 H + 2		1 2
DW-C		Carter INTERNO Telaio INTERNAL Frame Carter	H - 55		1
DW-D		Carter Laterale Anta INT INTERNAL Sash Side Carter	L/2 - 7		4
			H - 73		4
DW-E		Fermavetro Glass Holder	L/2 - 99		4
			H - 165		4
DW-G		Carter Frontale Anta INT INTERNAL Sash Front Carter	H - 121		1

Lavorazioni e Montaggi degli elementi in Legno sono analoghi a quelli descritti per quelli in Alluminio
Tools and Assemblies of the wooden elements are similar to those described for the aluminium ones.

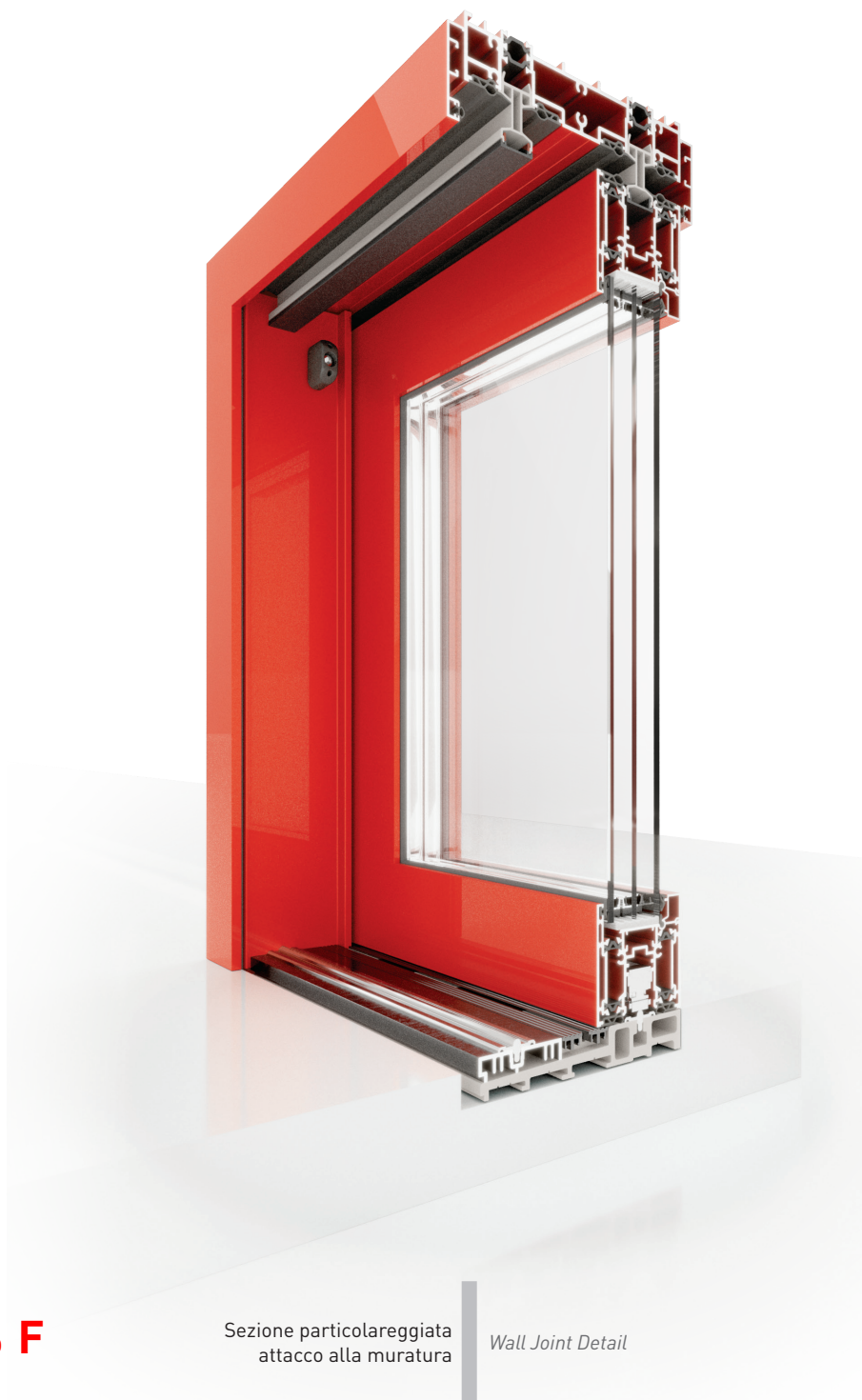

Attacco alla Muratura
Wall Joint

Gruppo **F**

Sezione particolareggiata
attacco alla muratura

Wall Joint Detail



POSA QUALITÀ

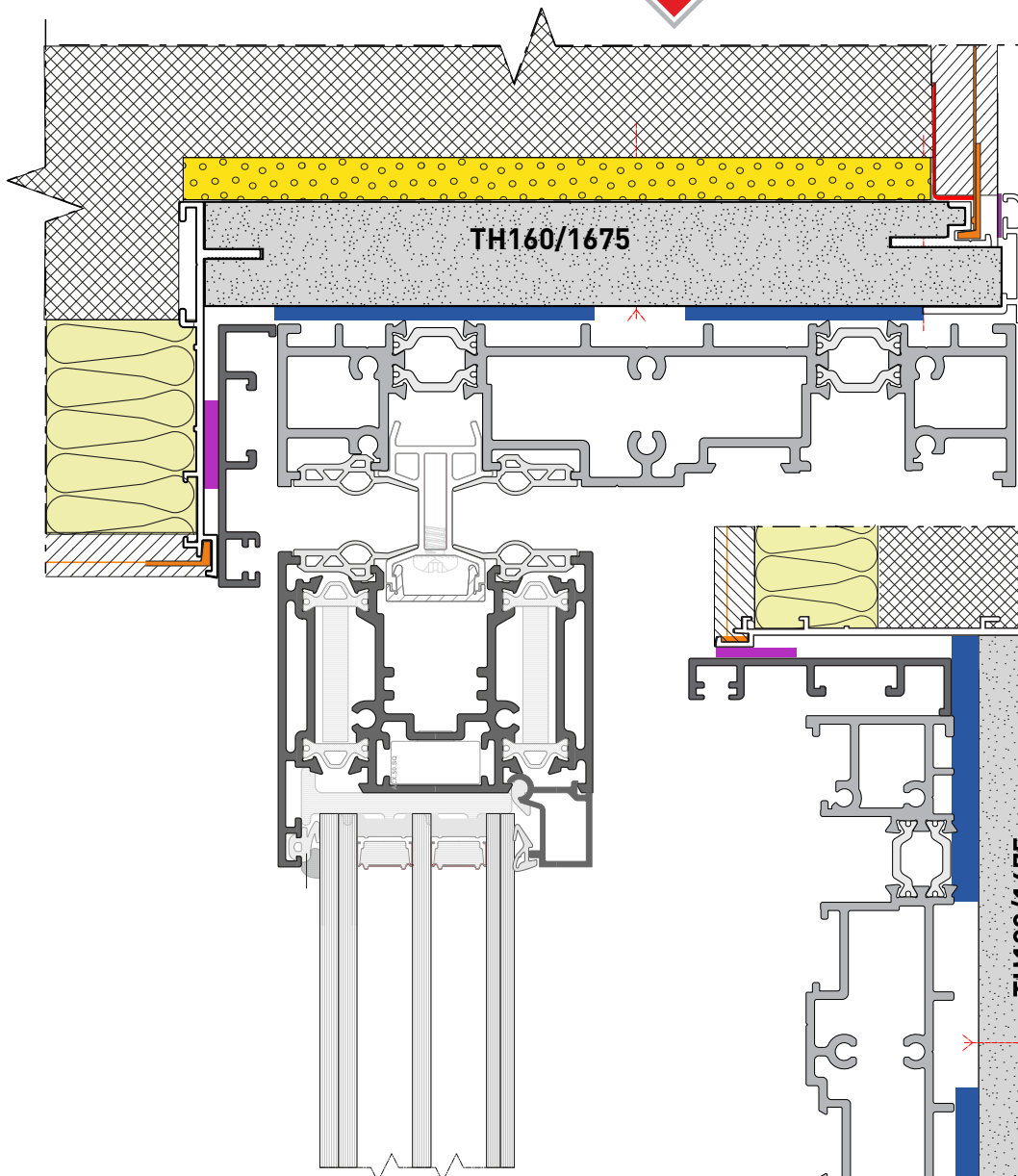

Sezione Orizzontale
Horizontal Section

Sezione Verticale
Vertical Section

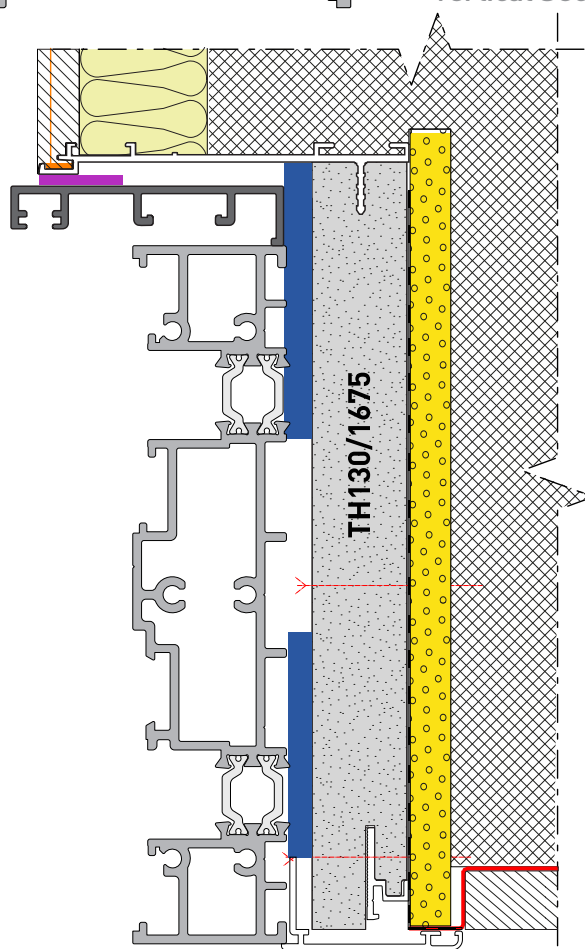

LEGENDA MATERIALI
MATERIALS LEGEND

	Muratura Brickwall		PQ.1008 Nastro Autoadesivo 9x2 PQ.1008 Adhesive Tape 9x2		PQ.1003 Freno al Vapore [Pellicola Interna] 70 mm. PQ.1003 Steam Barrier [Internal Film] 70 mm.
	Intonaco Plaster		PQ.1007 Nastro 600Pa 15/1-4 PQ.1007 Tape 600Pa 15/1-4		PQ.1013 Profilo Portaintonaco Plaster net profile
	Isolamento Insulation		Nastro Multifunz. 54/2-10 PQ.1009.G Munifunc. Tape 54/10 PQ.1009.G		
	Controtelaio THERMAL Wall frame THERMAL		PQ.1012 Schiuma Poliuretanic PQ.1012 Polyurethane Foam		

DETTAGLI, NORMATIVE DI RIFERIMENTO E LISTE MATERIALI SONO DISPONIBILI SUL CATALOGO POSA QUALITÀ SUL SITO TWIN SYSTEMS

DETAILS, REFERENCE STANDARDS AND MATERIAL LISTS ARE AVAILABLE IN THE QUALITY INSTALLATION CATALOG ON THE TWIN SYSTEMS WEBSITE



SEZIONE VERTICALE

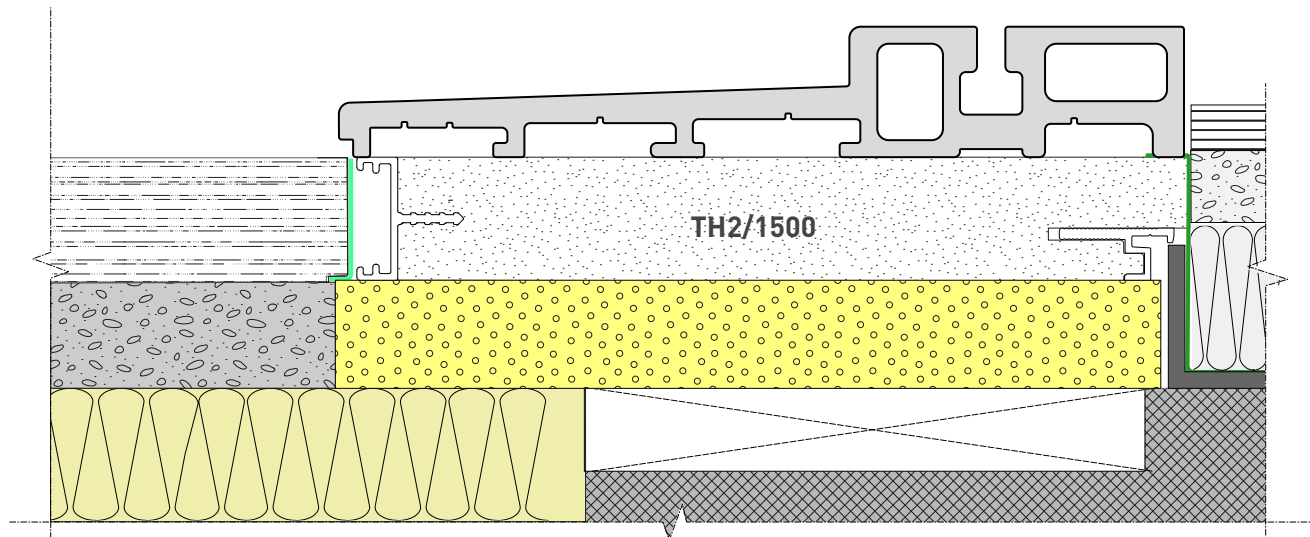

Soglia Termica
Thermic Threshold

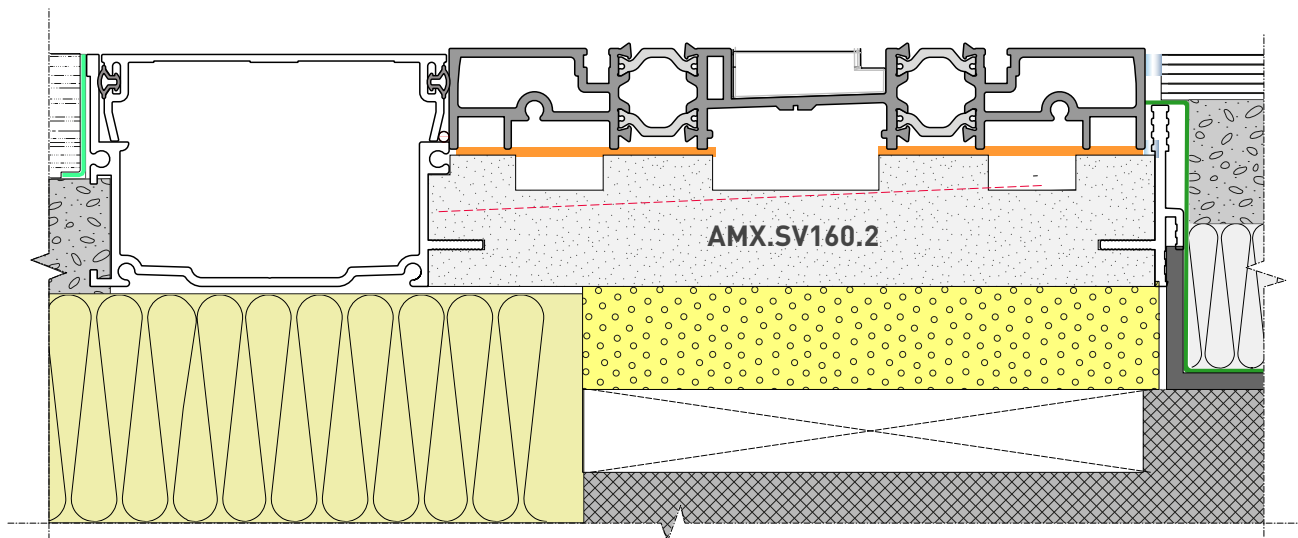

Filo Pavimento
Floor Level

LEGENDA MATERIALI
MATERIALS LEGEND

	Paviment INT/EXT INT/EXT Flooring		Isolamento Termico Thermic Insulation		PQ.1012 Schiuma Poliuretanic PQ.1012 Polyurethane Foam
	Massetto Screed		PQ.1005 Guaina Estena EPDM 80 mm. PQ.1003 External Sheath EPDM 80 mm.		Soglia Termica Thermic Threshold
	Base Strutturale Structure		PQ.1010 Nastro PE 60x6 PQ.1010 Tape PE 60x6		
	Controtelaio THERMAL Wall frame THERMAL		PQ.1002/3/4 Freno al Vapore [Pellicola Interna] 70 mm. PQ.1002/3/4 Steam Barrier [Inner Film] 70 mm.		

DETTAGLI, NORMATIVE DI RIFERIMENTO E LISTE MATERIALI SONO DISPONIBILI SUL CATALOGO POSA QUALITÀ SUL SITO TWIN SYSTEMS
DETAILS, REFERENCE STANDARDS AND MATERIAL LISTS ARE AVAILABLE IN THE QUALITY INSTALLATION CATALOG ON THE TWIN SYSTEMS WEBSITE



CONTROTELAIO per HM16.113
COUNTERFRAME for HM16.113 Profile

AMX SV075L.1

Kit Controtelaio Perimetrale + Soglia c/Canalina di Drenaggio Integrata
Perimetral Counterframe + Threshold w/Integrated Drainage Channel

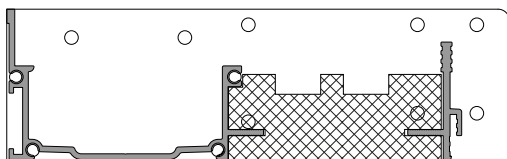
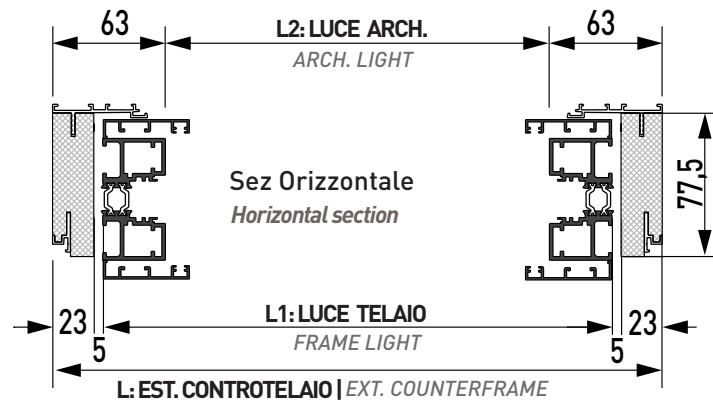
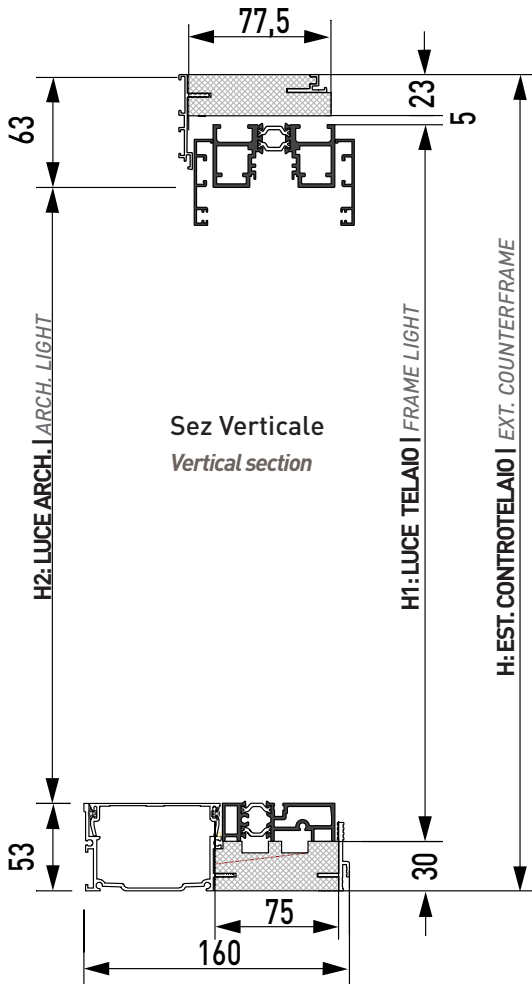
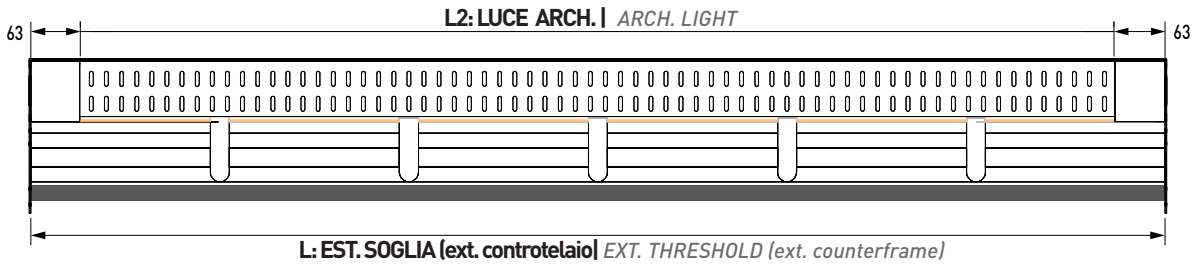

*Aletta disponibile in altre dimensioni
*Flap available in other sizes

AMXSV075.1 Soglia PVC 1 Binario c/vasca + Griglia + Tappi [Prodotto Finito]
PVC Threshold 2 Rails w/Drainage Canal + Drain + Caps [End Product]

AMXSG075.1 Soglia PVC 1 Binario c/vasca Esterna Griglia + Profilo Interno
PVC Threshold 2 Rails w/External Drainage Canal + Drain + Internal Profile

TH130.0775
CONTROTELAIO THERMAL UNO L. 77,5 mm. c/Aletta 30 mm.
THERMAL COUNTERFRAME UNO L. 175 mm. w/Flap 50 mm.



CONTROTELAIO per HX16.110

COUNTERFRAME for HX16.110 Profile

AMX SC160L.2

Kit Controtelaio Perimetrale + Soglia c/Canalina di Drenaggio Integrata
Perimetral Counterframe + Threshold w/Integrated Drainage Channel

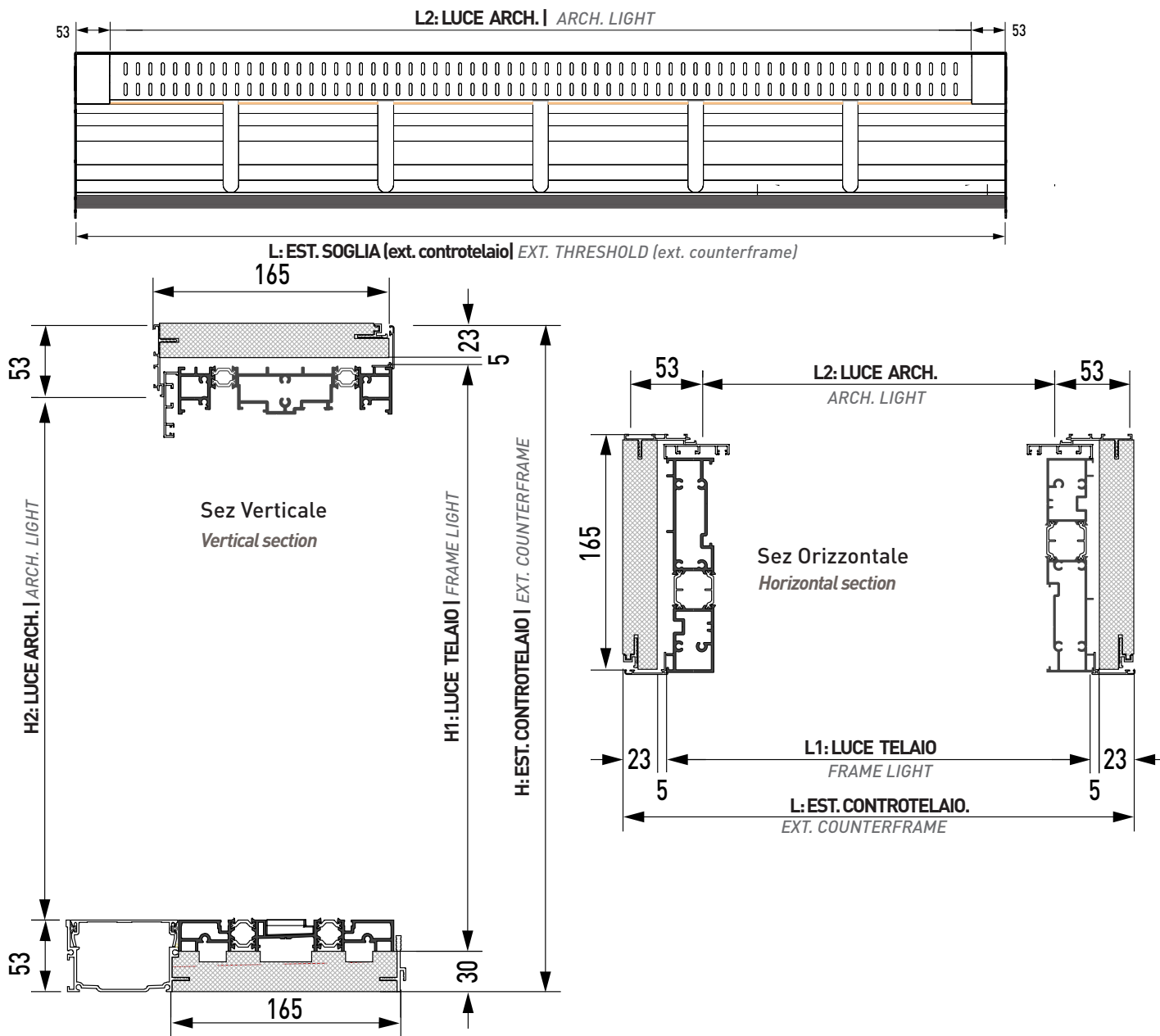

***Aletta disponibile in altre dimensioni**
*Flap available in other sizes

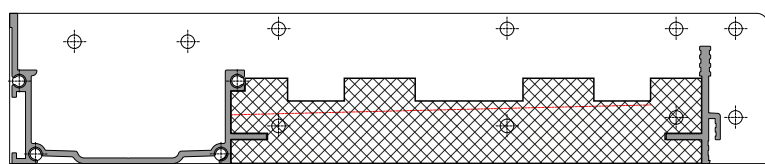

AMXSV160.2 Soglia PVC 2 Binari c/vasca + Griglia + Tappi [Prodotto Finito]
PVC Threshold 2 Rails w/Drainage Canal + Drain + Caps [End Product]

AMXSG160.2 Soglia PVC 2 Binari c/vasca Esterna Griglia + Profilo Interno
PVC Threshold 2 Rails w/External Drainage Canal + Drain + Internal Profile

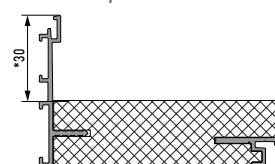

TH130.1675
CONTROTELAIO THERMAL UNO L. 175 mm. c/Aletta 50 mm.
THERMAL COUNTERFRAME UNO L. 175 mm. w/Flap 50 mm.



CONTROTELAIO per HX16.110 predisposizione Zanzariera

COUNTERFRAME for HX16.110 Profile mosquito net profile prearrangement

AMX SC160LZ.2

Kit Controtelaio Perimetrale + Soglia c/Canalina di Drenaggio Integrata
Perimetral Counterframe + Threshold w/Integrated Drainage Channel

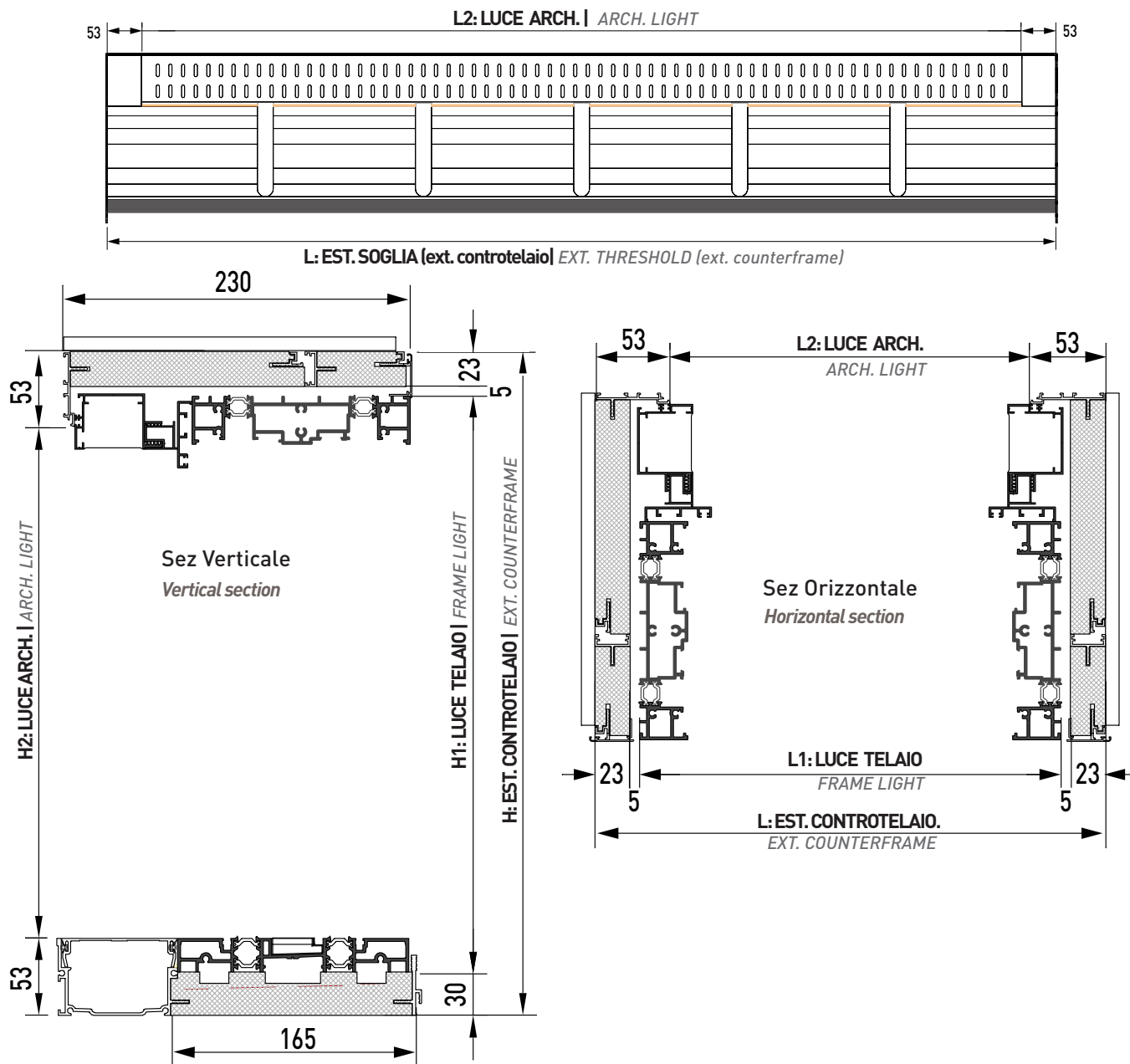

*Aletta disponibile in altre dimensioni
*Flap available in other sizes

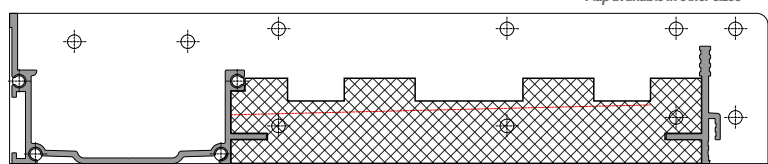

- AMXSV160.2** Soglia PVC 2 Binari c/vasca + Griglia + Tappi [Prodotto Finito]
PVC Threshold 2 Rails w/Drainage Canal + Drain + Caps [End Product]
- AMXSG160.2** Soglia PVC 2 Binari c/vasca Esterna Griglia + Profilo Interno
PVC Threshold 2 Rails w/External Drainage Canal + Drain + Internal Profile

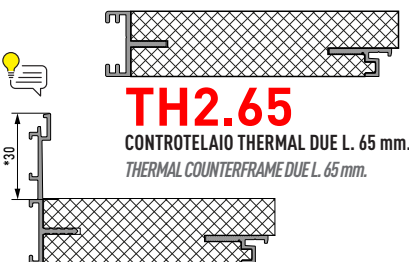

TH2.65
CONTROTELAIO THERMAL DUE L. 65 mm.
THERMAL COUNTERFRAME DUE L. 65 mm.

- TH130.1675**
CONTROTELAIO THERMAL UNO L. 175 mm. c/Aletta 50 mm.
THERMAL COUNTERFRAME UNO L. 175 mm. w/Flap 50 mm.

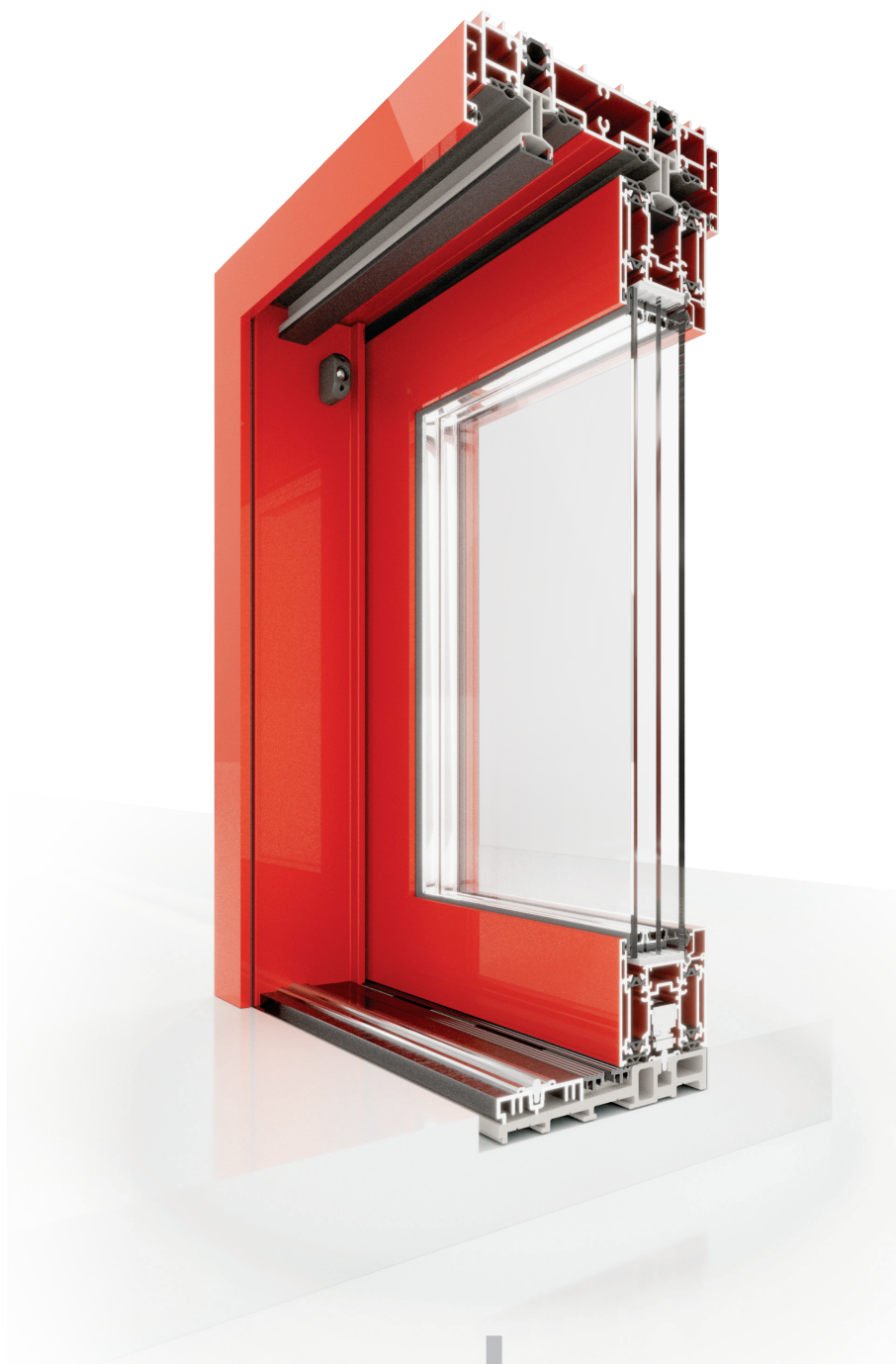

Gruppo G

Schemi Lavorazioni
Frese
Attrezzatura

*Tooling Systems
Cutters Equipments
Milling*

TELAIO

MAIN FRAME

- ESPLOSO ASSONOMETRICO
- AXONOMETRIC EXPLODED VIEW

Mobile + Fisso
Sliding + Fixed

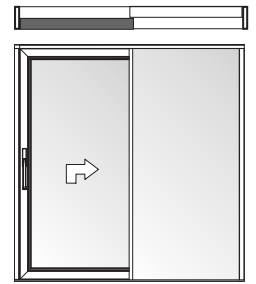

Anta | Sash 90°

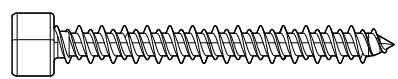
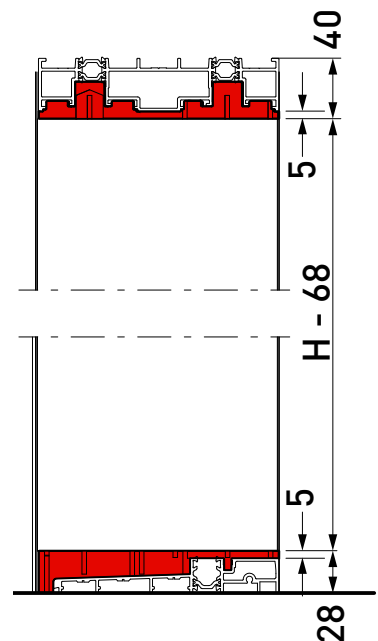
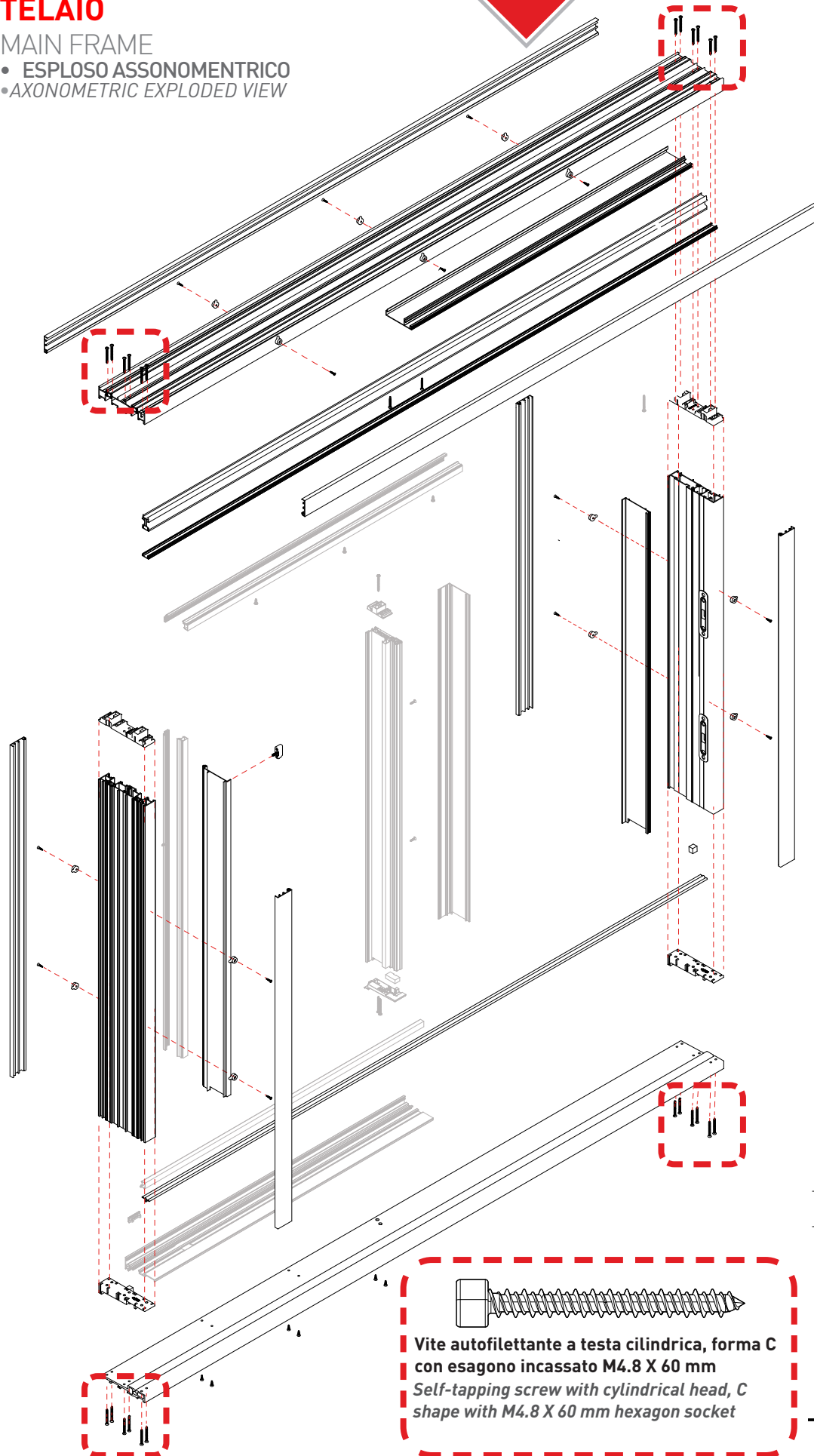

Vite autofilettante a testa cilindrica, forma C con esagono incassato M4.8 X 60 mm
Self-tapping screw with cylindrical head, C shape with M4.8 X 60 mm hexagon socket

TELAIO
MAIN FRAME

Mobile + Fisso
Sliding + Fixed

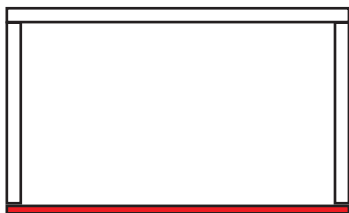

- Lavorazione SOGLIA HX16.107 DRENAGGIO LATO FISSO
- Treshold HX16.107 Tooling for DRAINAGE

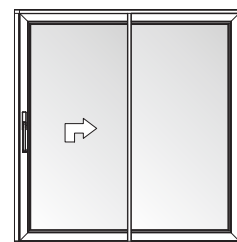
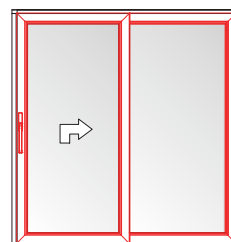

Anta | Sash 45°

Anta | Sash 90°

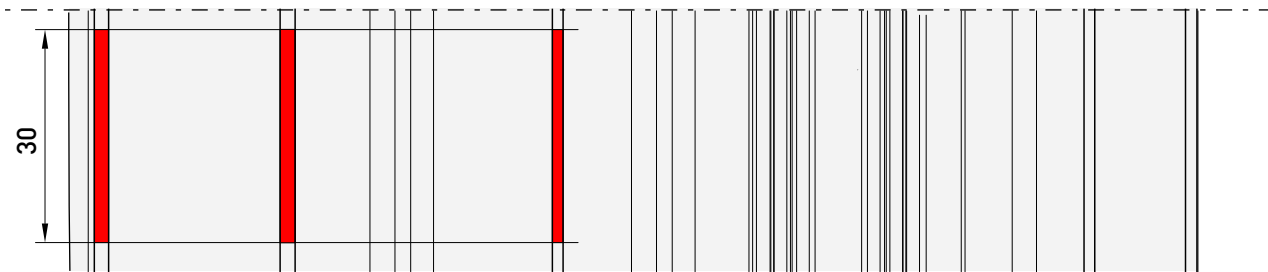
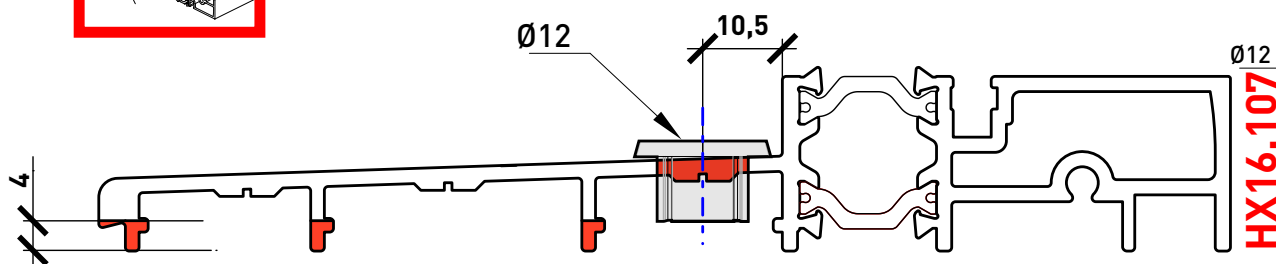
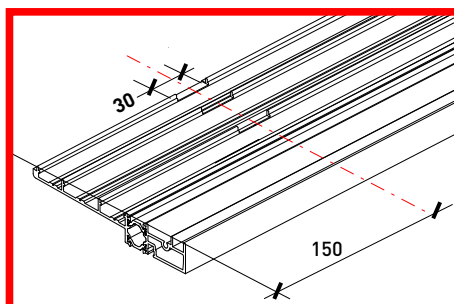
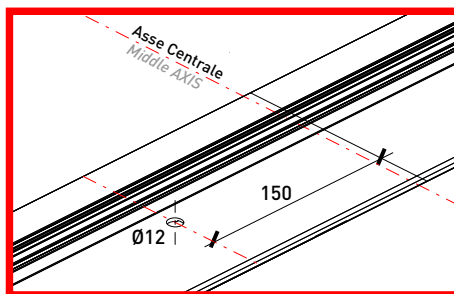
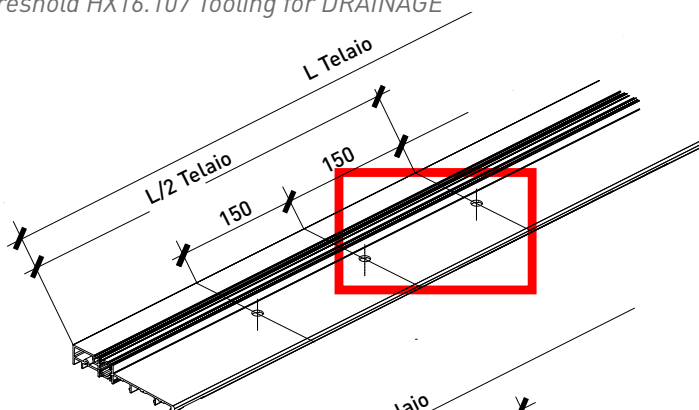

Vista INFERIORE | Bottom View

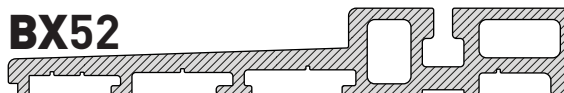

ATTENZIONE Stesse Lavorazioni per la Soglia Temica BX52
IMPORTANT Same Toolings for BX52 Thermic Treshold



TELAIO
MAIN FRAME

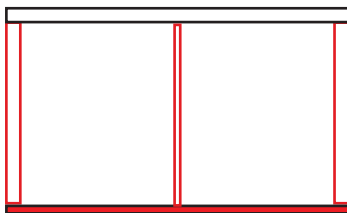

Mobile + Fisso
Sliding + Fixed

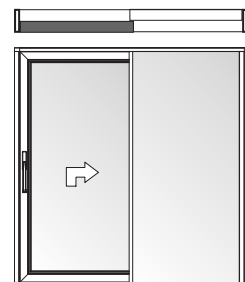

- Lavorazione SOGLIA HX16.107 Montanti Centrali + Lateralali
- Treshold HX16.107 Tooling for Lateral + Central Transoms

Anta | Sash 90°

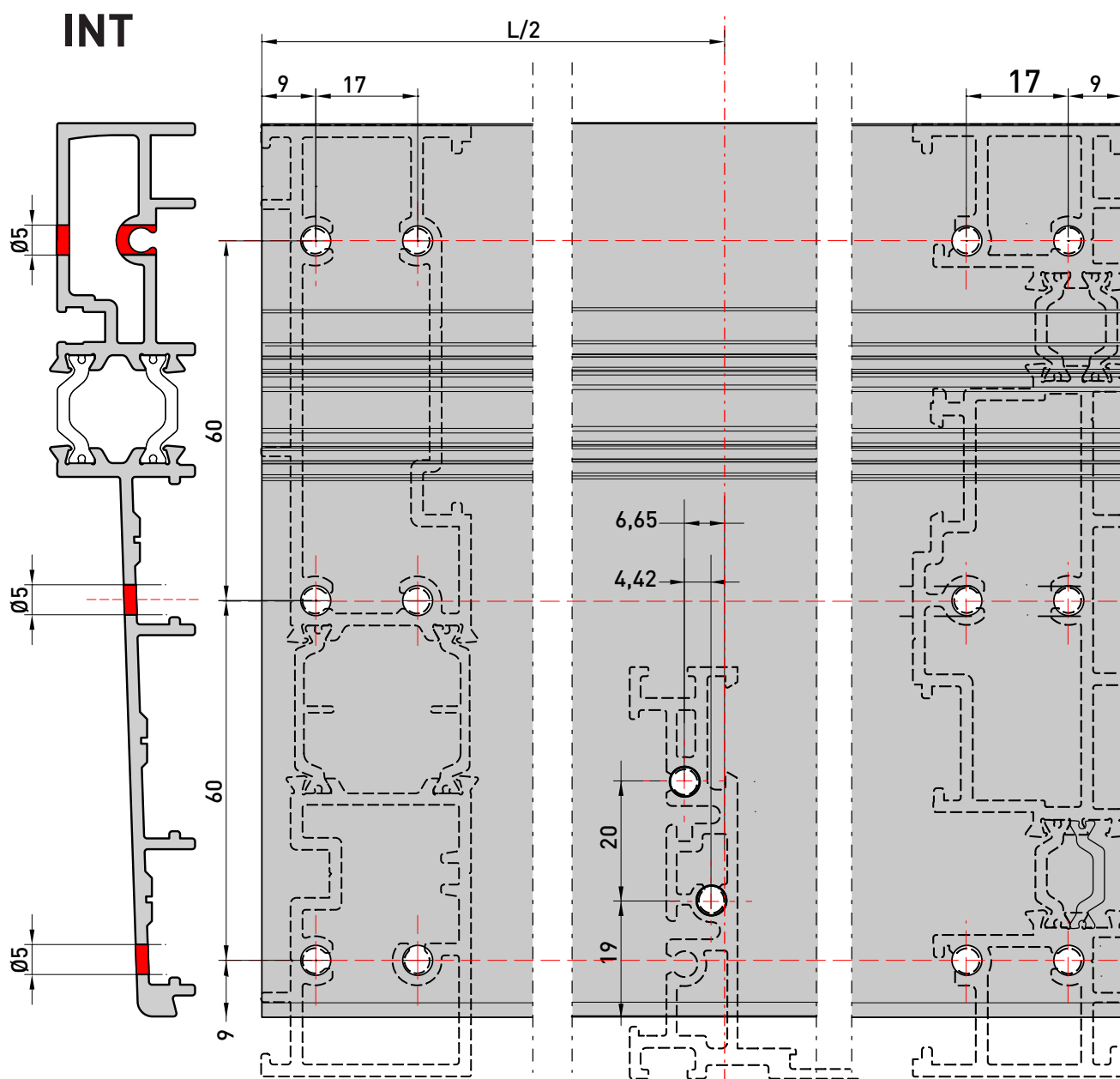

HX16.107
EXT

HX16.105

BX48

HM16.111

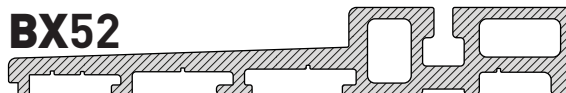

ATTENZIONE Stesse Lavorazioni per la Soglia Temica BX52
IMPORTANT Same Toolings for BX52 Thermic Treshold

TELAIO
MAIN FRAME

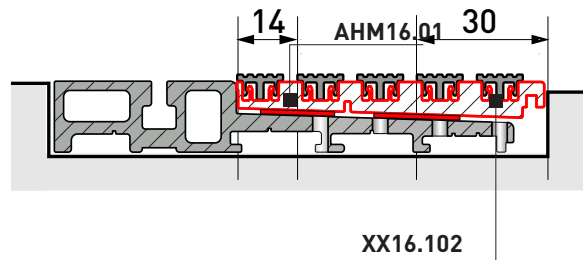
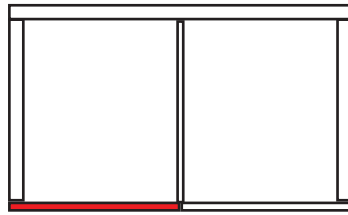

Mobile + Fisso
Sliding + Fixed

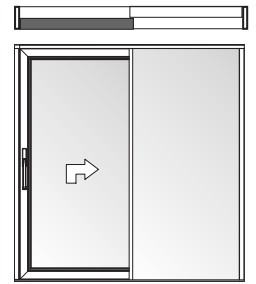

Anta | Sash 90°

- Drenaggio Soglia FILOPAVIMENTO HX16.107 + HM16.506 e HM 16.507 LATO MOBILE
- FLOORLEVEL Treshold Drainage HX16.107 + HM 16.506 and HM16.507 SLIDING SASH SIDE

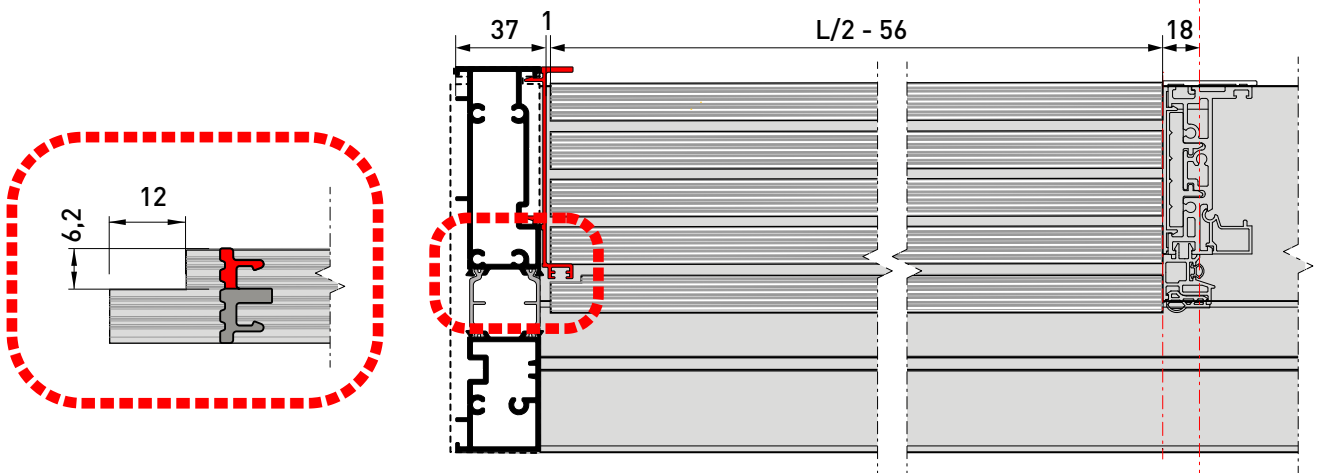
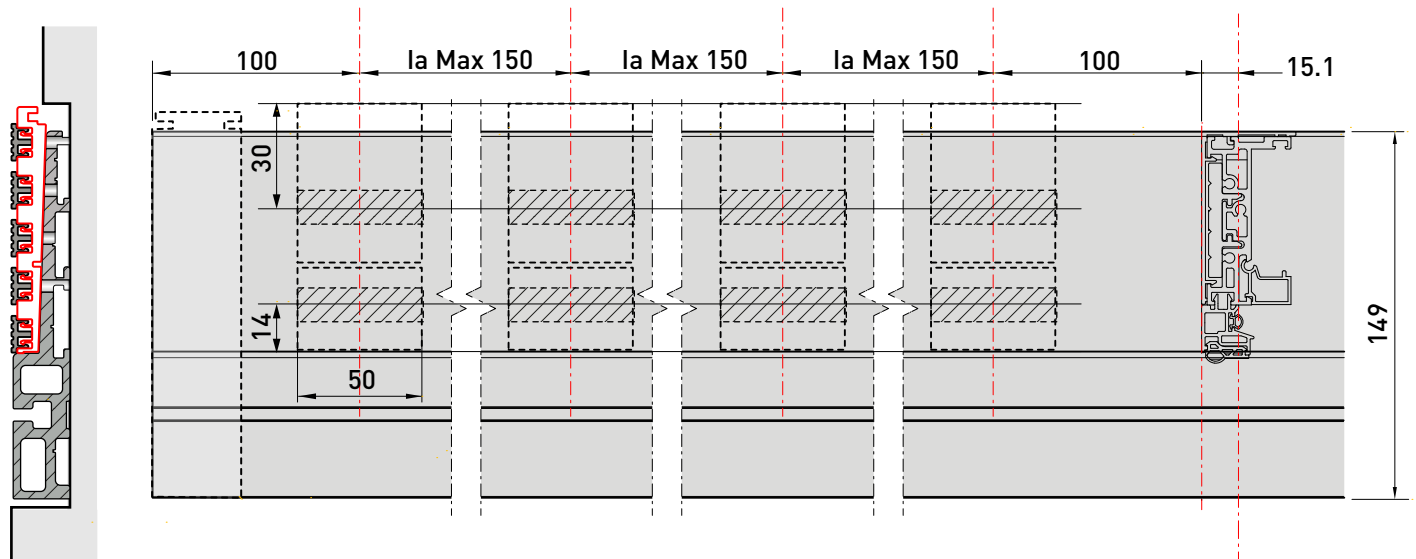
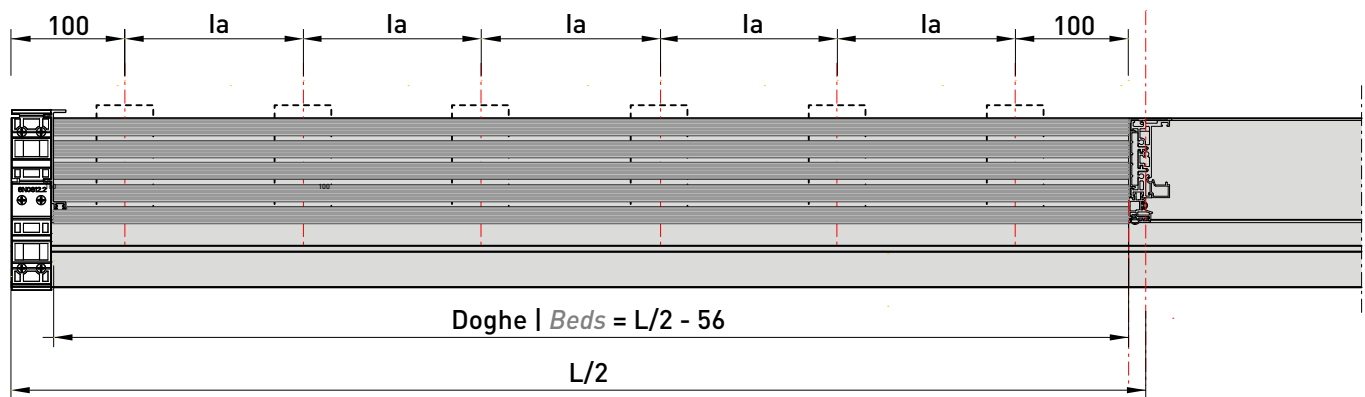



TELAIO
MAIN FRAME

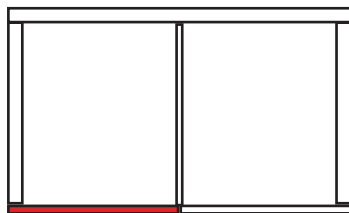

- Drenaggio Soglia FILOPAVIMENTO
HX16.107 + HM16.506 e HM 16.507 LATO MOBILE
- FLOOR LEVELreshold Drainage
HX16.107 + HM 16.506 and HM16.507 SLIDING SASH SIDE

Mobile + Fisso
Sliding + Fixed

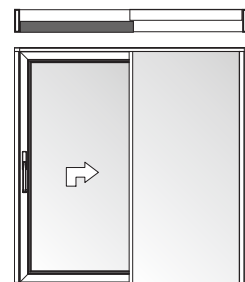

Anta | Sash 90°

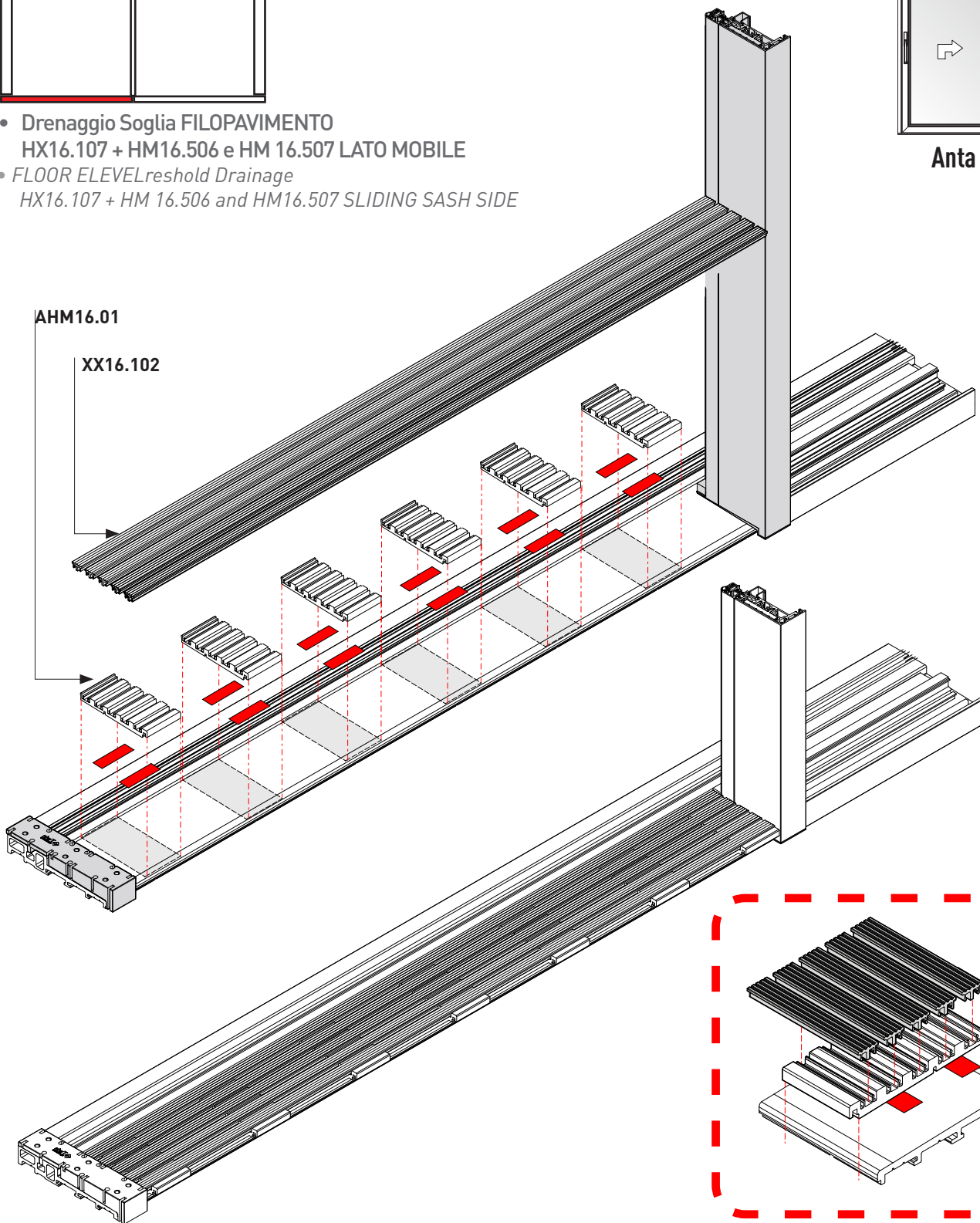

BX52

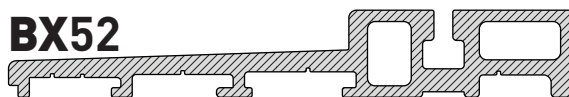

ATTENZIONE Stesse Lavorazioni per la Soglia Temica BX52
IMPORTANT Same Toolings for BX52 Thermic Treshold



TELAIO
MAIN FRAME

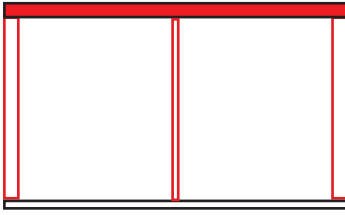

- Lavorazione Traverso Superiore HX16.106
- Tooling Upper Transom HX16.106

Mobile + Fisso
Sliding + Fixed

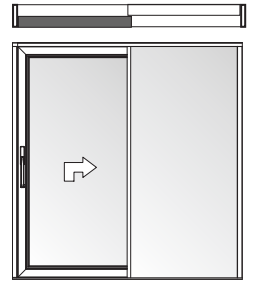

Anta | Sash 90°

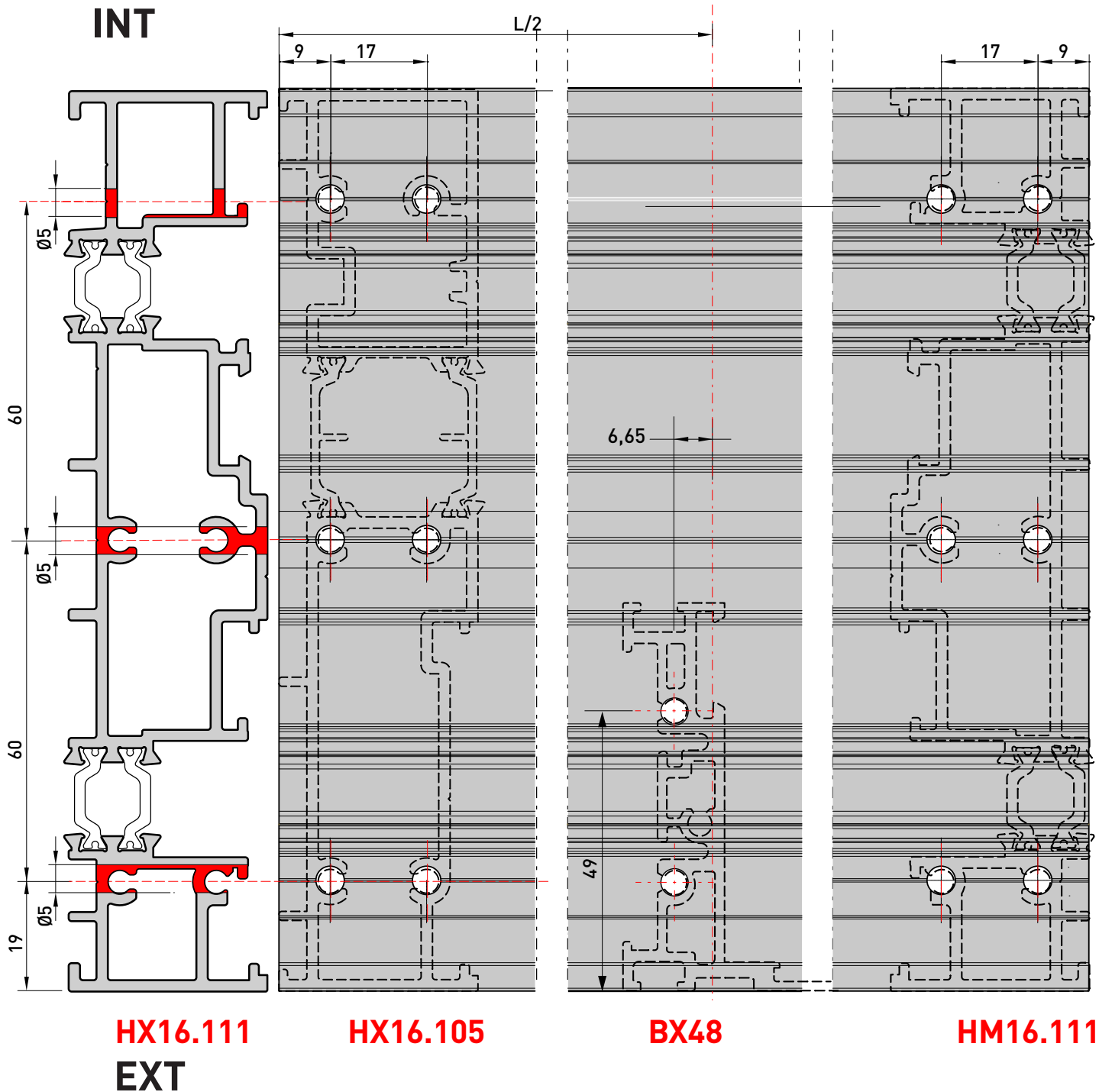

TELAIO
MAIN FRAME

Mobile + Fisso
Sliding + Fixed

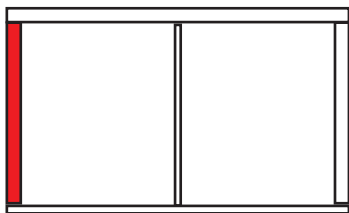

- Lavorazione Montante Laterale HX16.105
- Transom HX16.105 Tooling

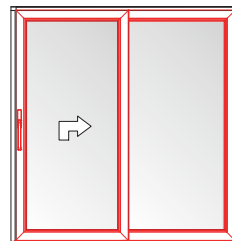

Anta | Sash 45°

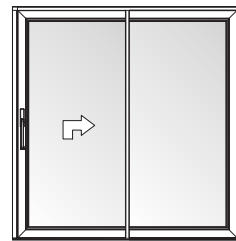

Anta | Sash 90°

NB. Lavorazioni su Anta e HGanci Tav G37
NB. Sash Tooling and Hook Height Position see Tab. G37

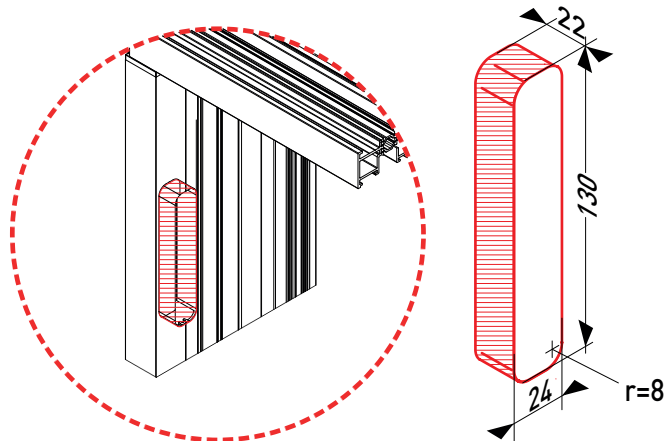
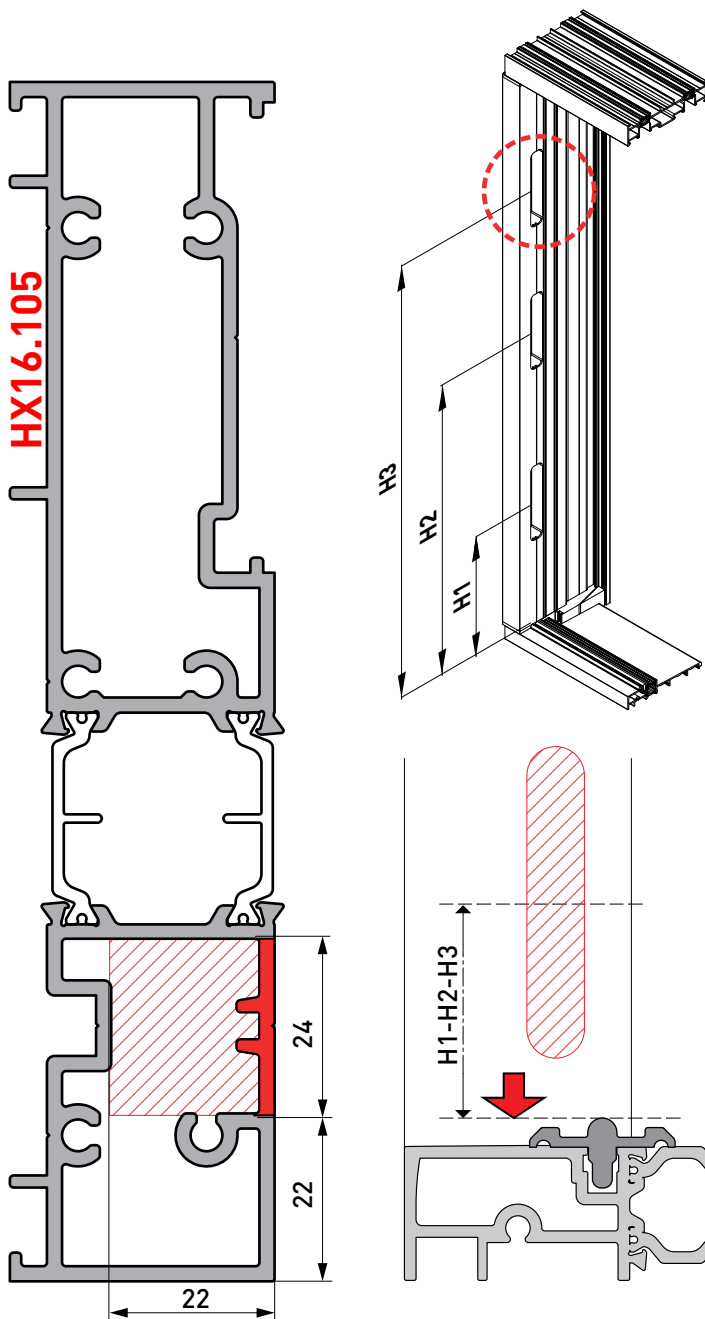

CODICE	L Asta	H1	H2	H3
HM16.6732.2	1305	210	550	-
HM16.6732.3	1900	210	1080	-
HM16.6732.4	2500	210	1678	-
HM16.6732.5	2800	210	1210	2110
HM16.6732.6	3300	210	1410	2510
HM16.6732.7	3800	210	1410	2510



TELAIO
MAIN FRAME

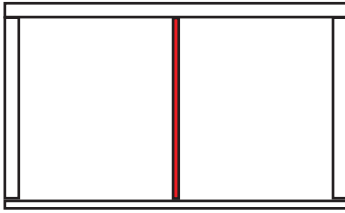

- Lavorazione BX48
- BX48 Tooling

Mobile + Fisso
Sliding + Fixed

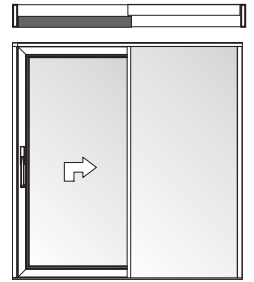

Anta | Sash 90°

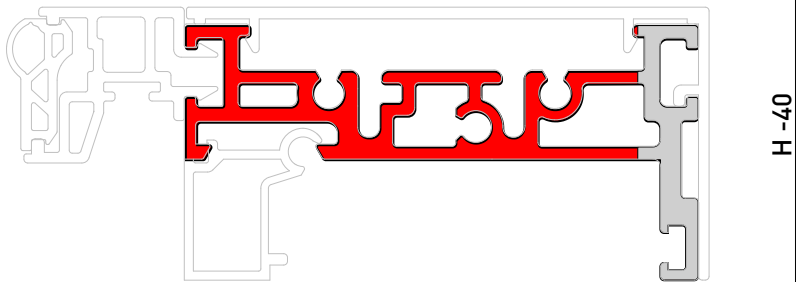
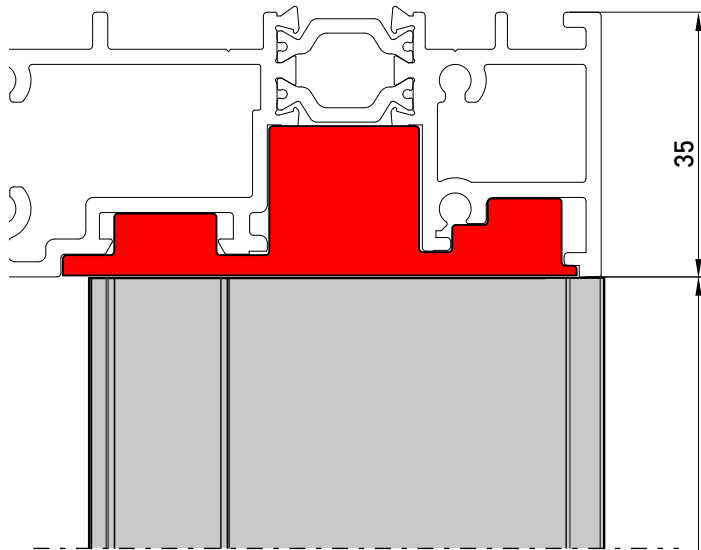

BX48

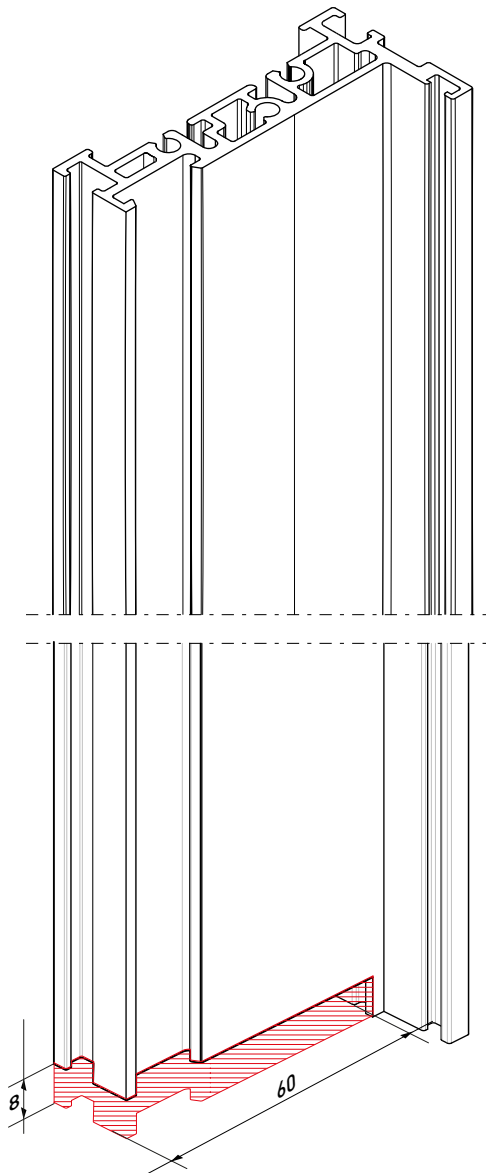
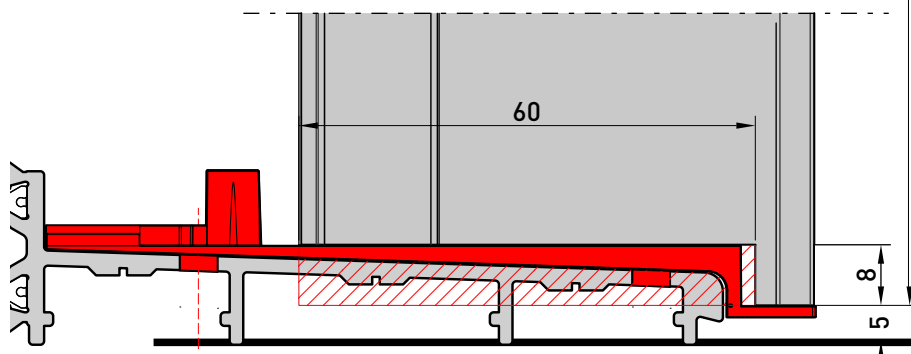

TELAIO
MAIN FRAME

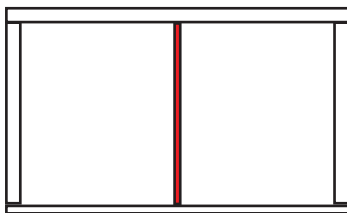

- Installazione Rinforzo Montante Centrale HM16.308 + BX50
- Central Mullion Reinforcement HM16.308 + BX50 Installing

Mobile + Fisso
Sliding + Fixed

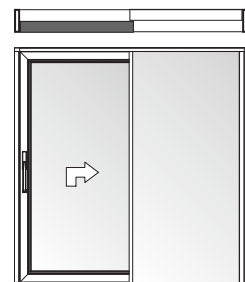

Anta | Sash 90°

LATO SUPERIORE
UPPER SIDE

HM16.308

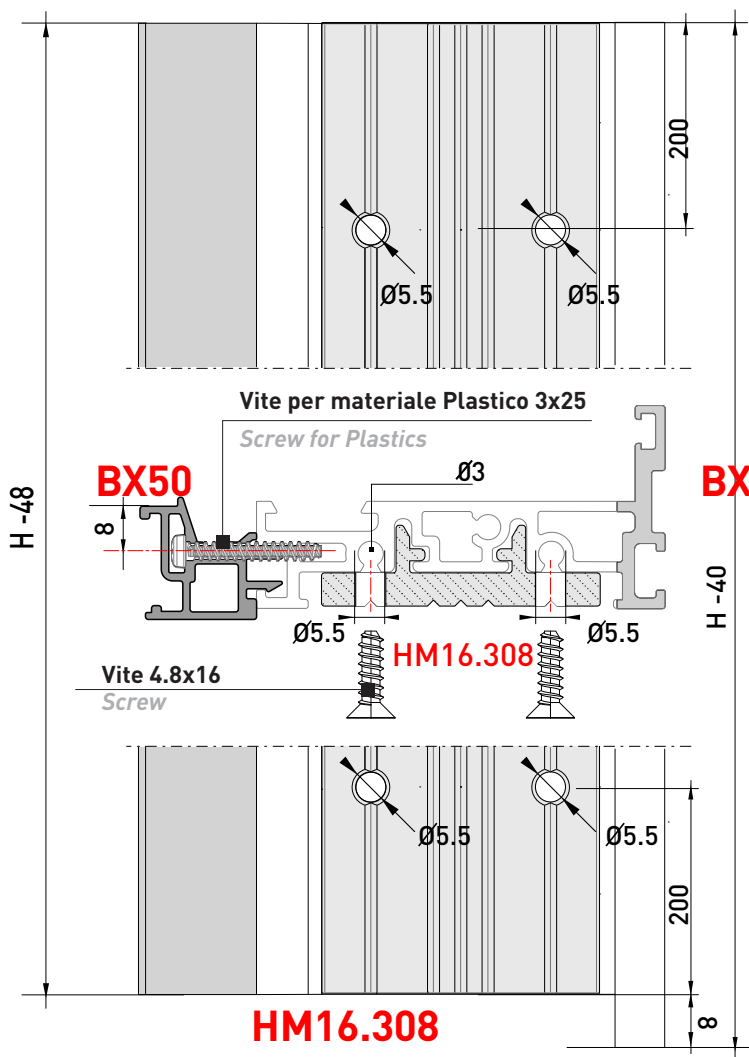

LATO INFERIORE
BOTTOM SIDE

HM16.308

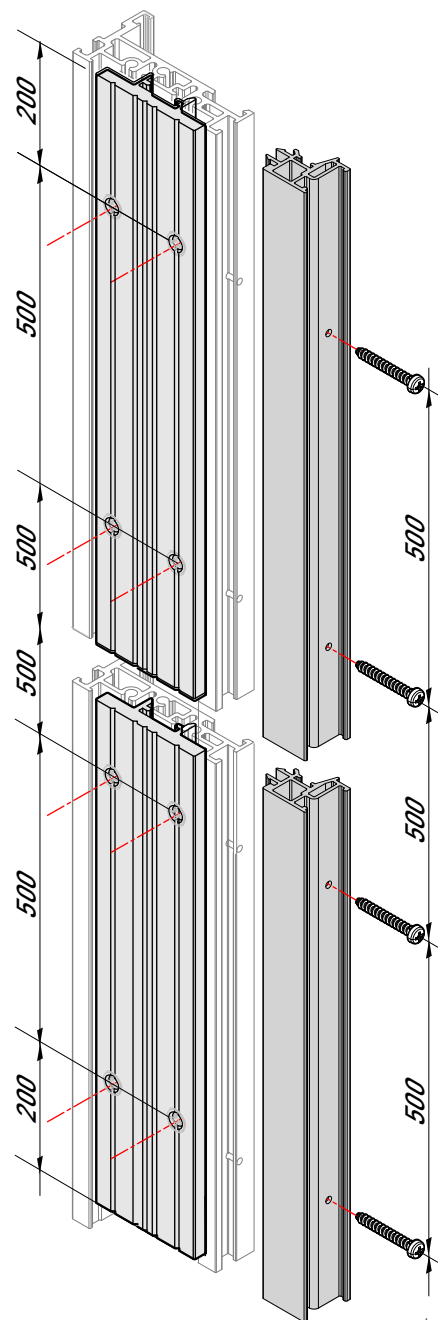

Inserimento ad Infilare di HM16.308 su BX48

Insert HM16.306 on BX48



TELAIO
MAIN FRAME

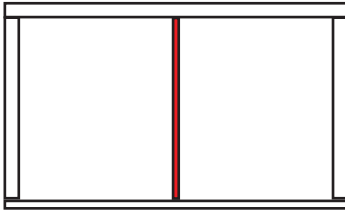

- Lavorazione Carter HM16.306 Montante Centrale lato Fisso
- Tooling for Cenral Mullion Carter HM16.306 for Fixed Side

Mobile + Fisso
Sliding + Fixed

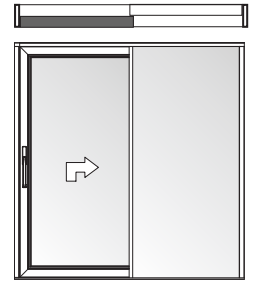

Anta | Sash 90°

Assemblaggio ad Infilare di HM16.3.306
Insert HM16.306

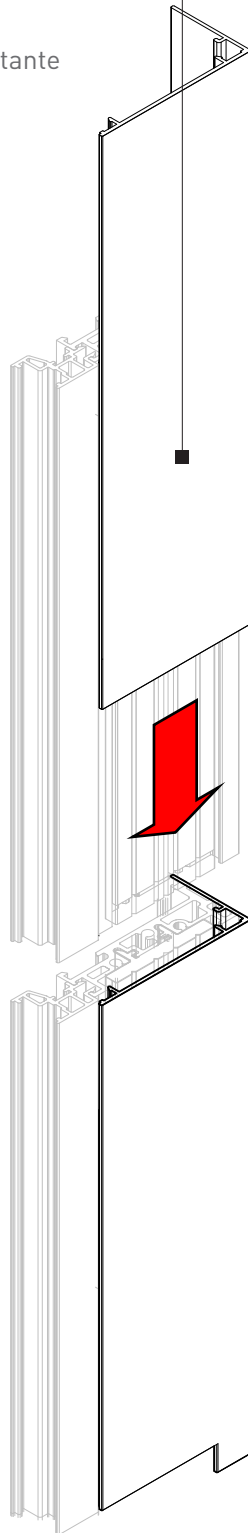

H -40 [Lato Fisso]

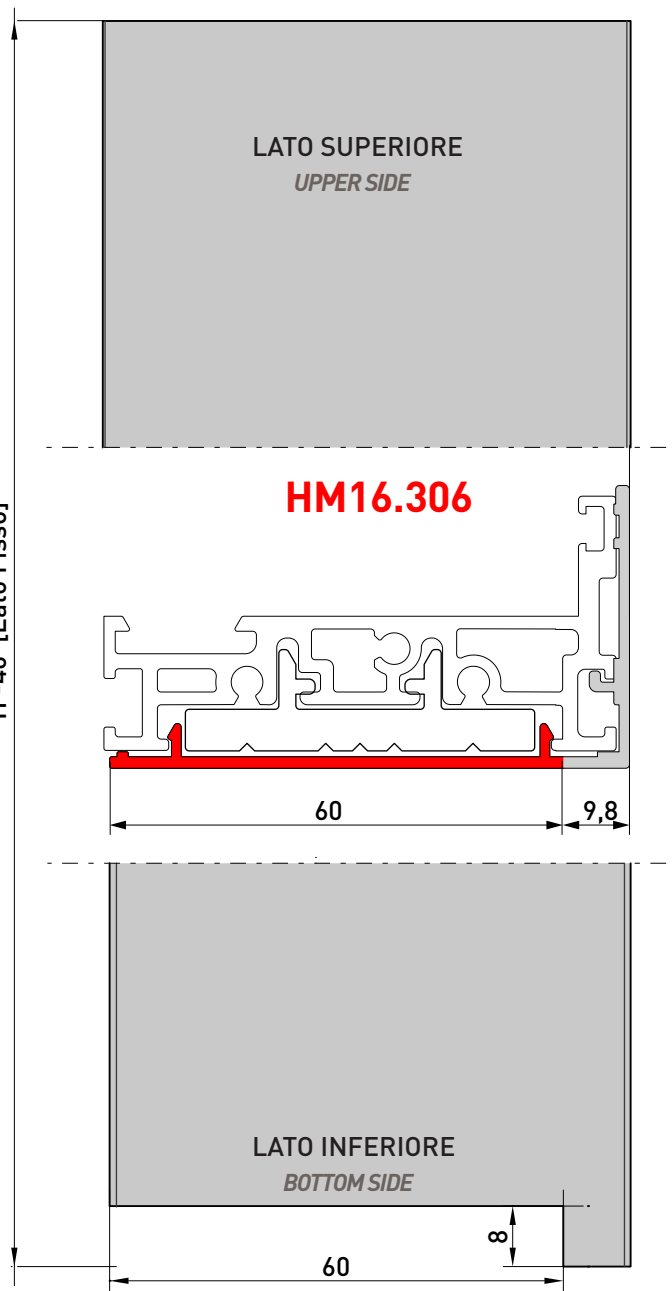

TELAIO
MAIN FRAME

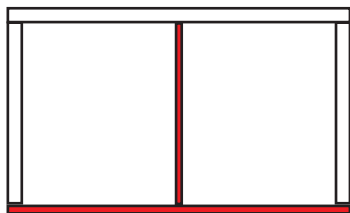

- Installazione Tappo di tenuta Inferiore su HX16.107/BX52
- Bottom Sealing Item Installation on HX16.101/BX52

Mobile + Fisso
Sliding + Fixed

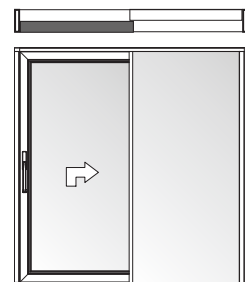

Anta | Sash 90°



Montaggio Tappo di Tenuta Inferiore
Bottom Sealing Cap Assembling

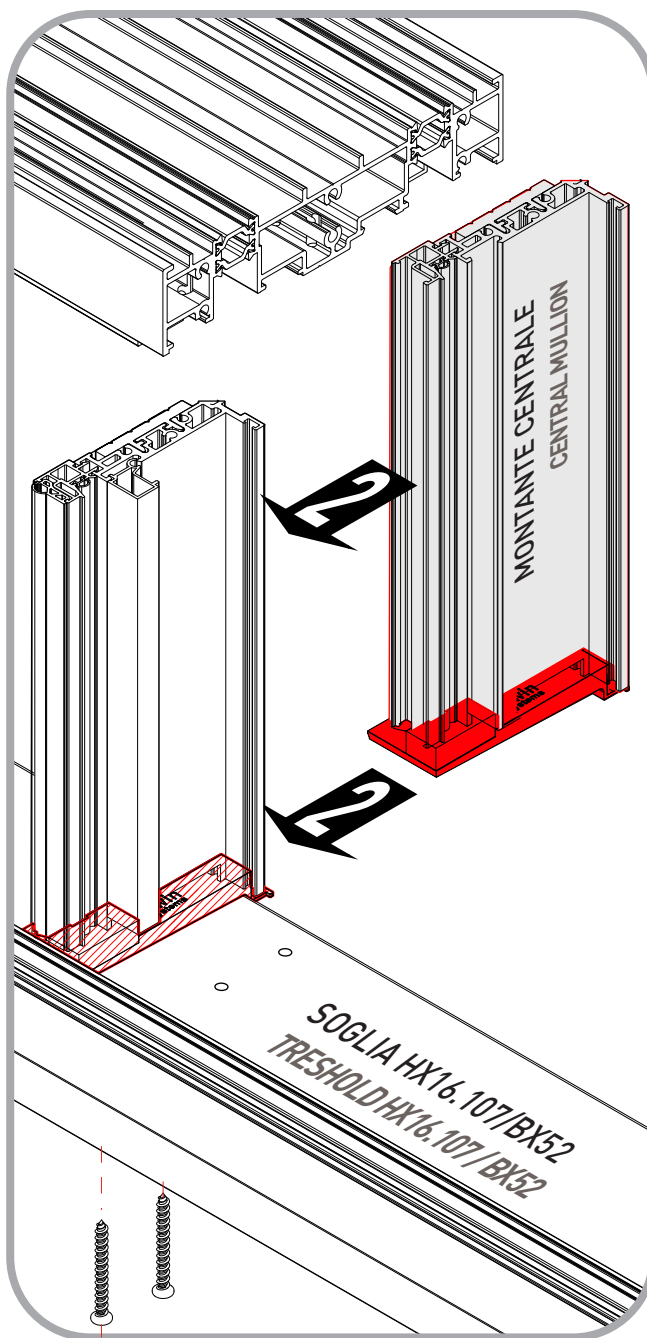

Installazione Montante Centrale su Telaio
Central Mullion Installation on Main frame

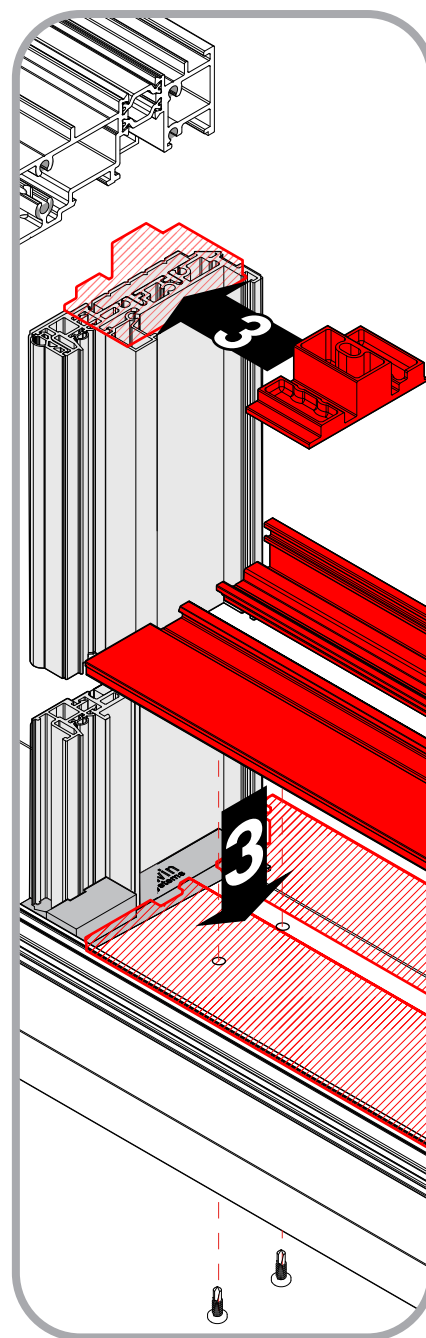

Montaggio Tappo di Tenuta Superiore e Fermavetro inferiore su Soglia
Upper Sealing Cap e Bottom Glass Holder Installation

TELAIO
MAIN FRAME

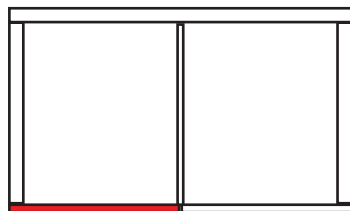

Mobile + Fisso
Sliding + Fixed

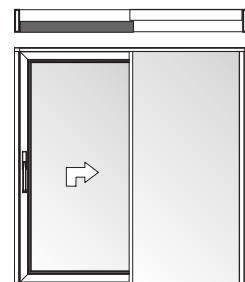

- Drenaggio Soglia HX16.107 + HM16.506 e HM 16.507 LATO FISSO
- *Threshold Drainage HX16.107 + HM 16.506 and HM16.507 FIXED SASH SIDE*

Anta | Sash 90°

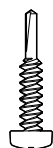
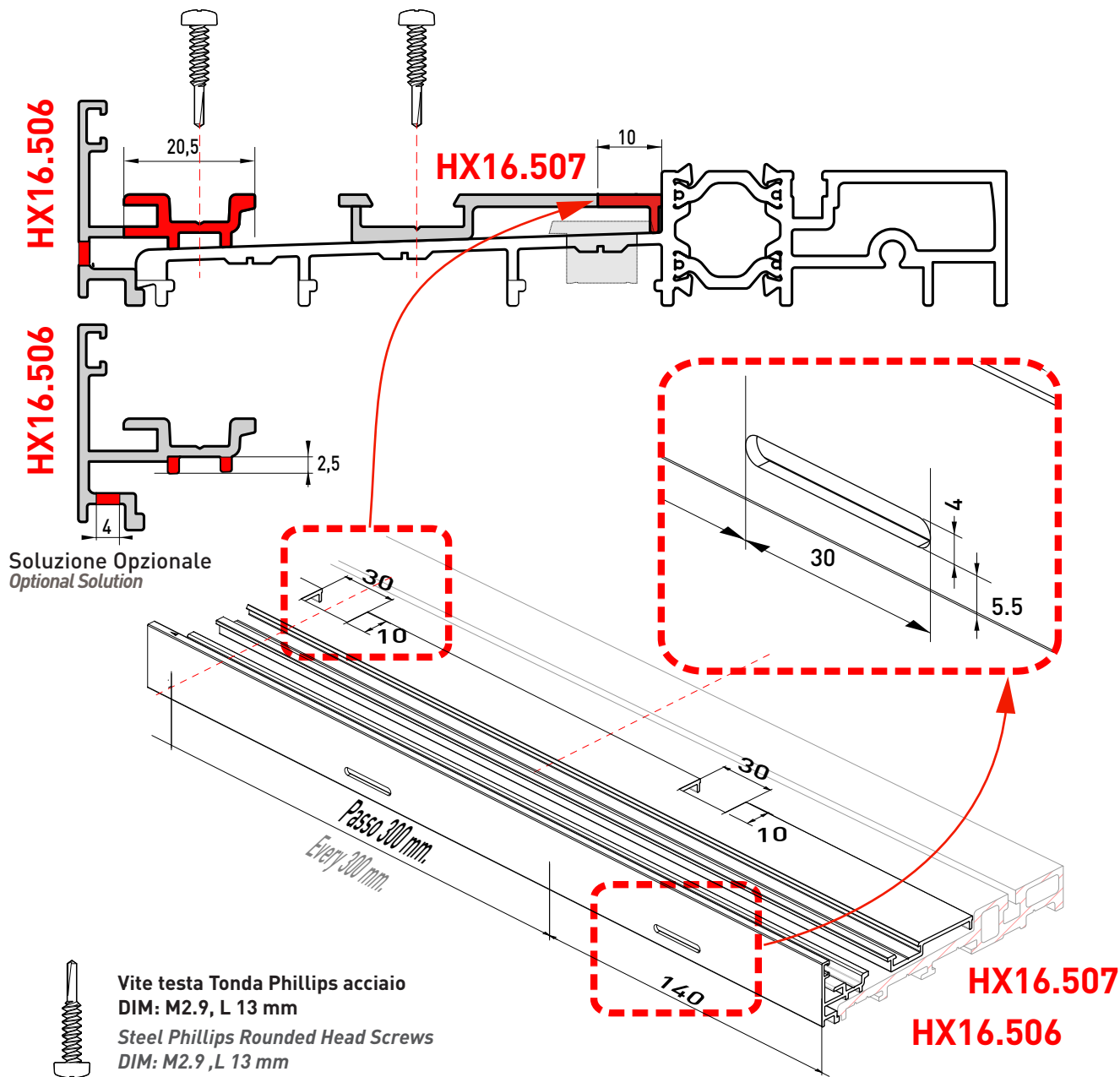

Vite testa Tonda Phillips acciaio
DIM: M2.9, L 13 mm
Steel Phillips Rounded Head Screws
DIM: M2.9, L 13 mm

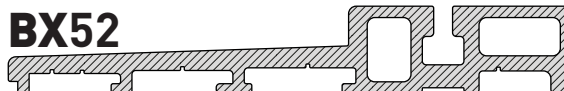

ATTENZIONE Stesse Lavorazioni per la Soglia Temica BX52
IMPORTANT Same Toolings for BX52 Thermic Threshold

TELAIO
MAIN FRAME

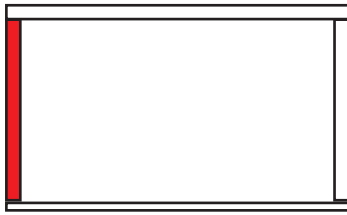

- Lavorazione Carter Laterale HM16.508 ESTERNO
- Tooling for Lateral Carter HM16.508 EXTERNAL



Mobile + Fisso
Sliding + Fixed

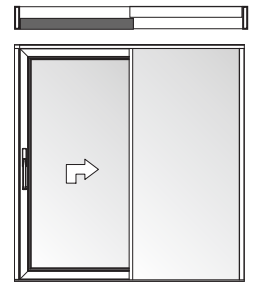

Anta | Sash 90°

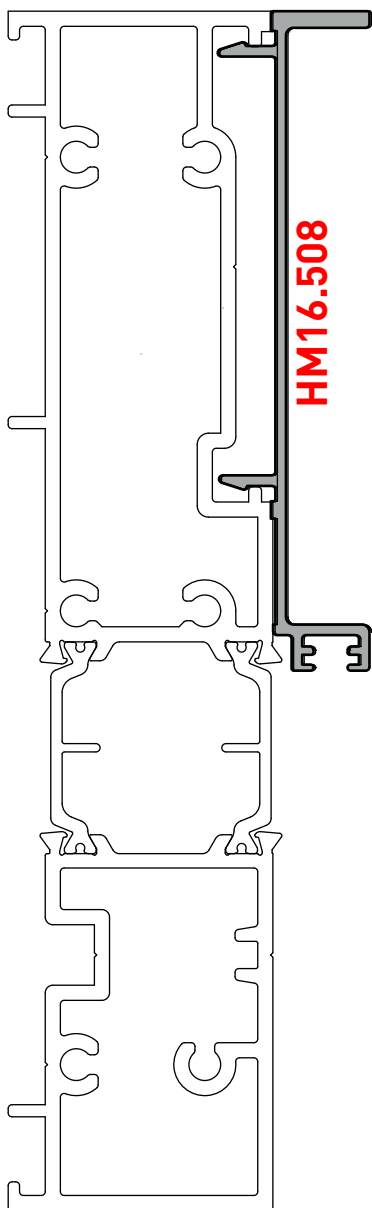
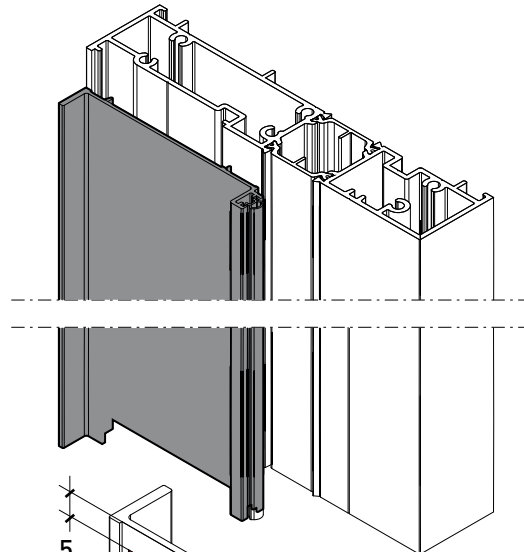

HM16.508

HX16.105

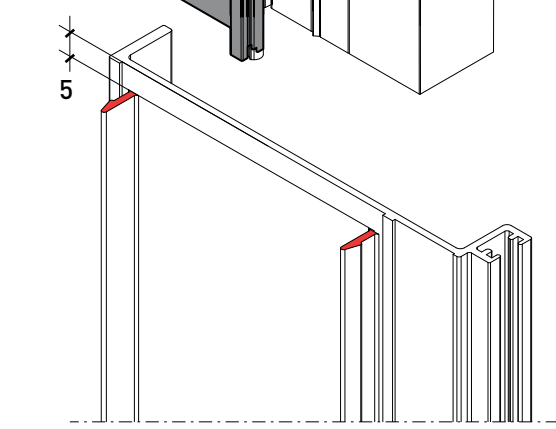

5

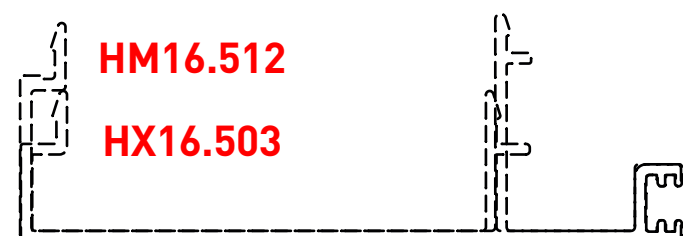

HM16.512

HX16.503

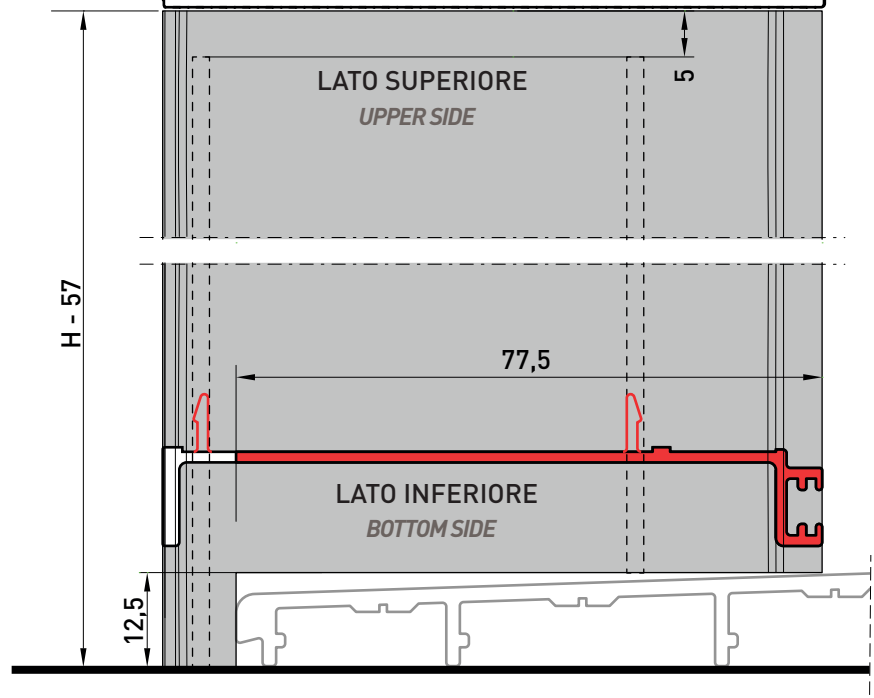

LATO SUPERIORE
UPPER SIDE

LATO INFERIORE
BOTTOM SIDE

H - 57

77,5

12,5

5

TELAIO
MAIN FRAME

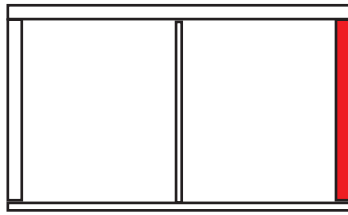

- Inserimento Spugnetta Montante Laterale HX16.105
- *Sponge Inserting at Side Mullion*

Mobile + Fisso
Sliding + Fixed

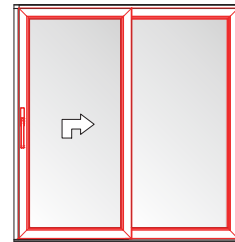

Anta | Sash 45°

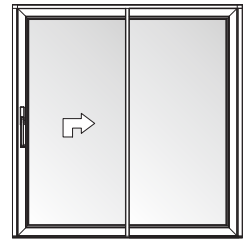

Anta | Sash 90°

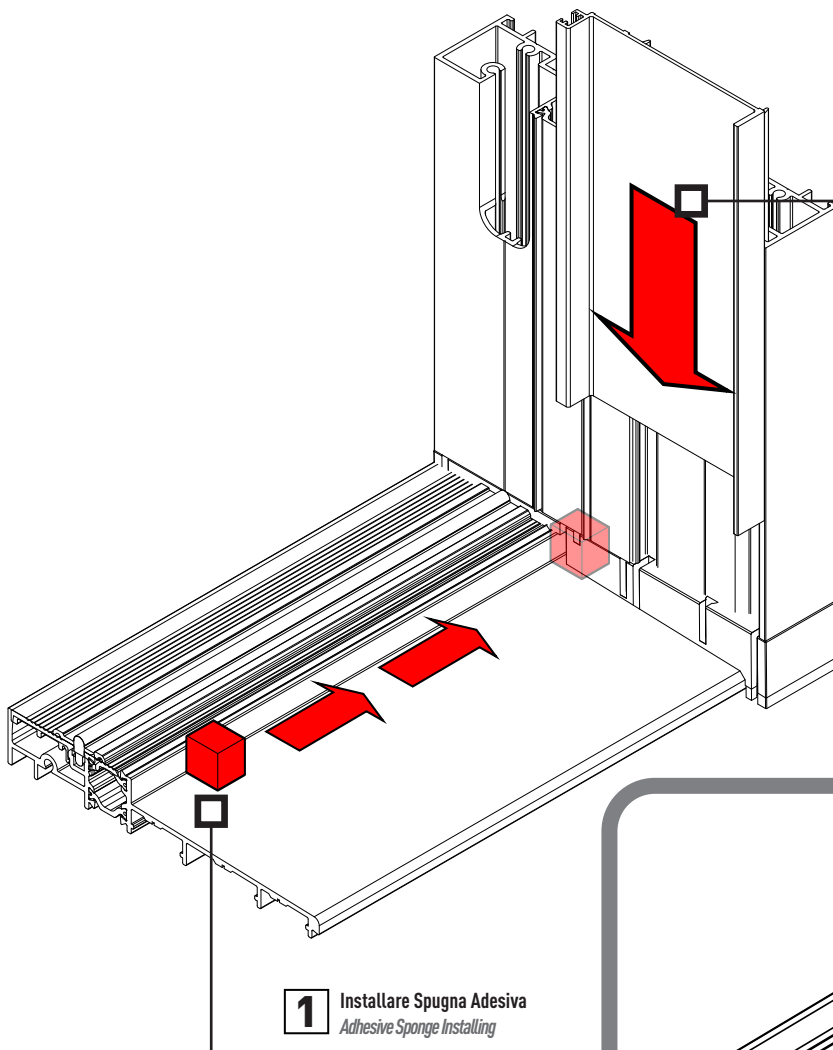

1 Installare Spugna Adesiva
Adhesive Sponge Installing

2 Posizionare Profilo HX16.105 e comprimere la Spugna per un corretto Funzionamento
Place Profile HM16.XXX and compress the Sponge for correct operation

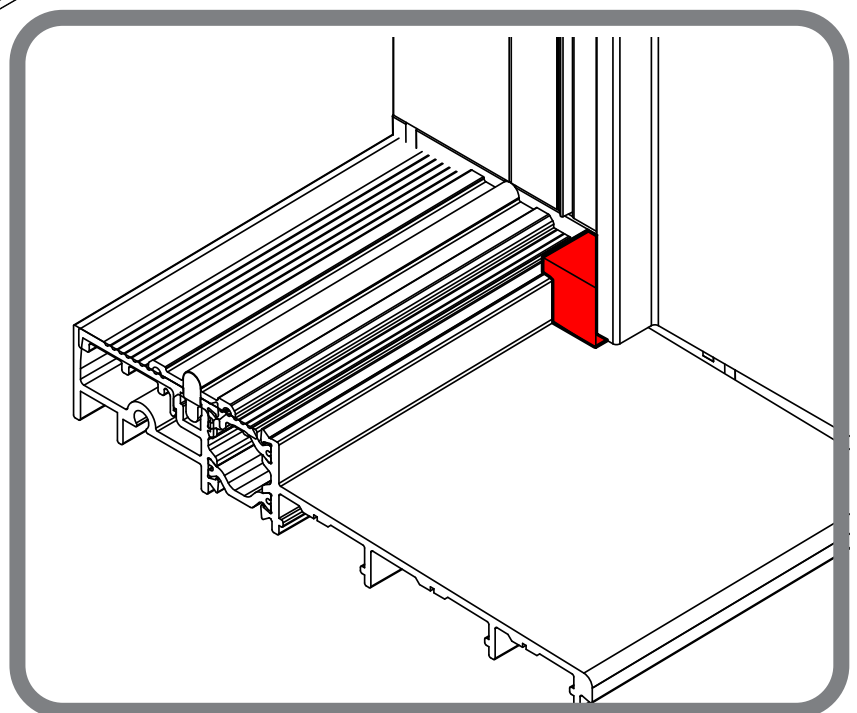



TELAIO
MAIN FRAME

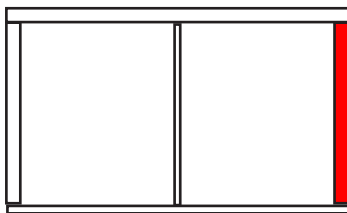

- Lavorazione Carter Laterale HM16.508 INTERNO
- Tooling for Lateral Carter HM16.508 INTERNAL

Mobile + Fisso
Sliding + Fixed

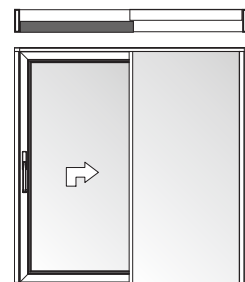

Anta | Sash 90°

Fine Corsa
Dumper

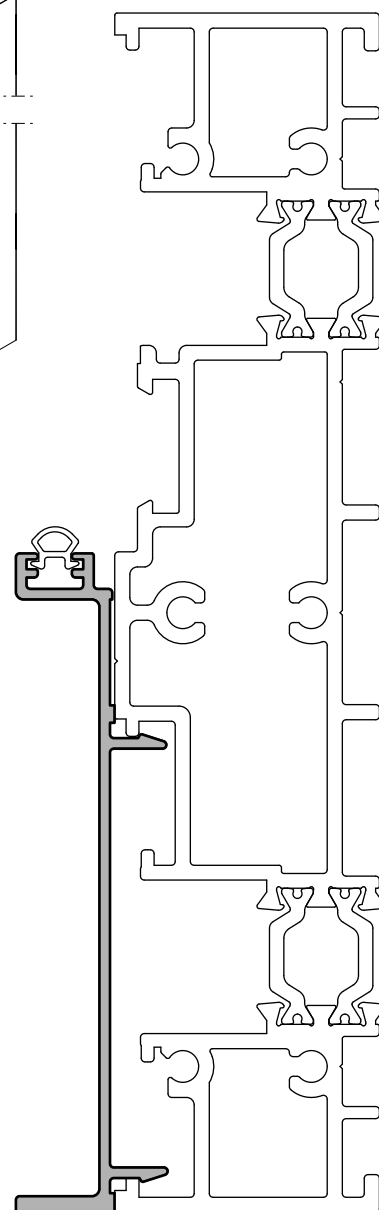
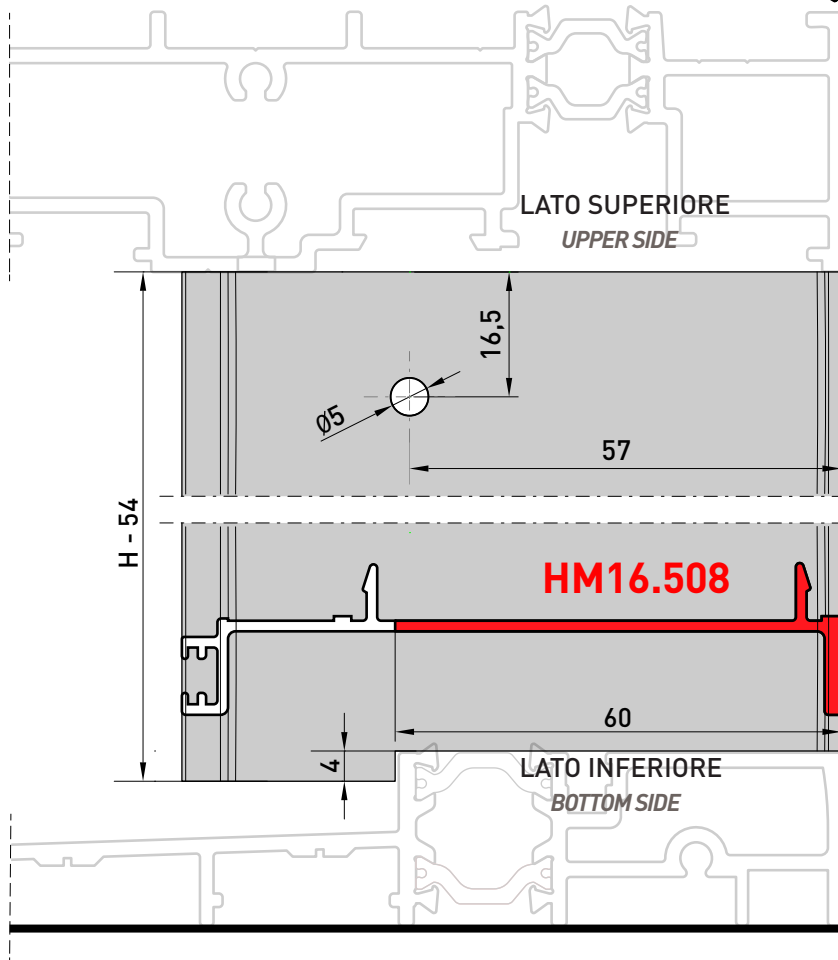
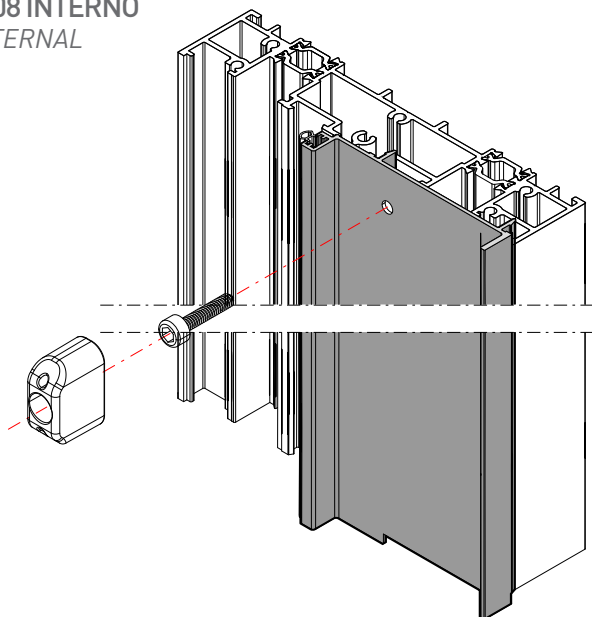

HM16.111



TELAIO
MAIN FRAME

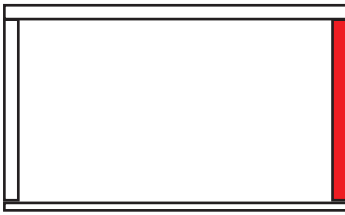

- Applicazione Battuta Vetro Fisso HM16.505 su Montante
- Assembling Glass Beading for Fixed Glazing HM16.505 on Mullion

Mobile + Fisso
Sliding + Fixed

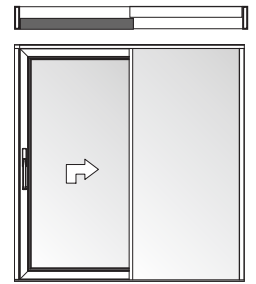

Anta | Sash 90°

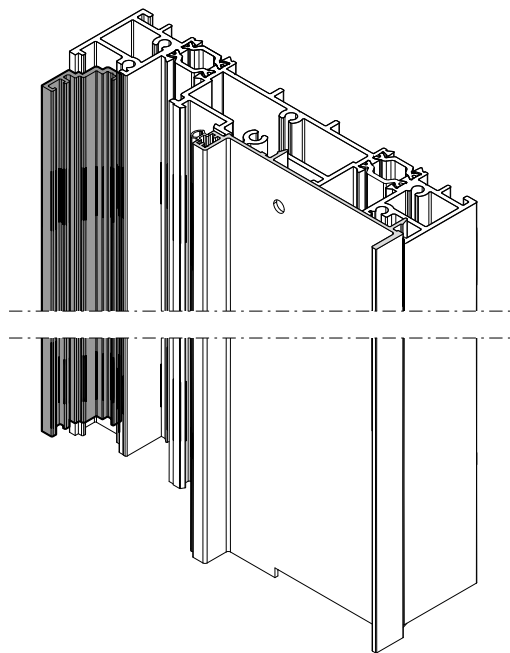

HM16.505

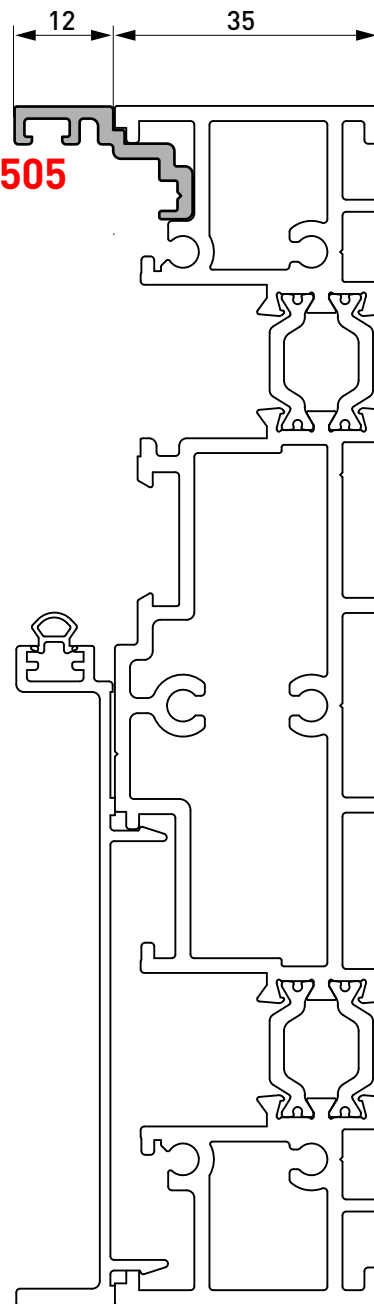

HM16.111

LATO SUPERIORE
UPPER SIDE

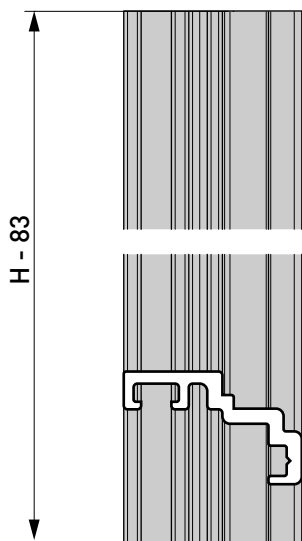

H - 83

LATO INFERIORE
BOTTOM SIDE



TELAIO
MAIN FRAME



- Applicazione Battuta Vetro Fisso HM16.505 su Traverso
- Assembling Glass Beading for Fixed Glazing HM16.505 on Transom

Mobile + Fisso
Sliding + Fixed

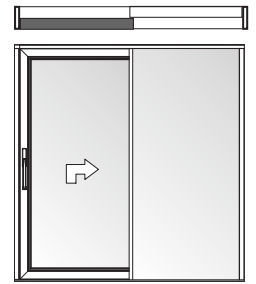

Anta | Sash 90°

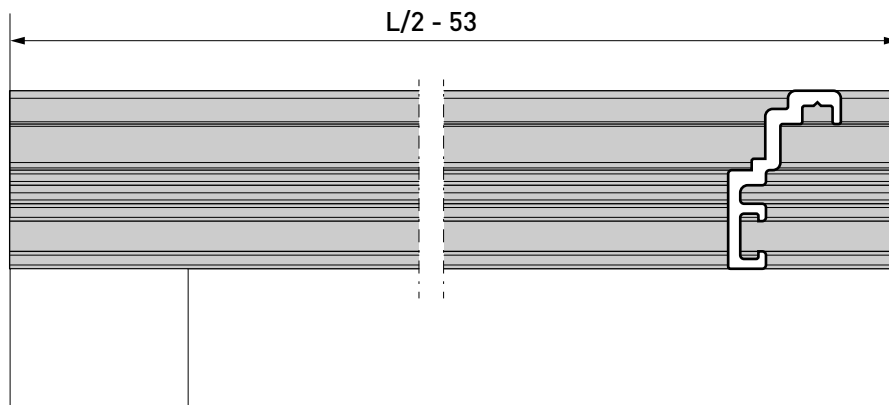
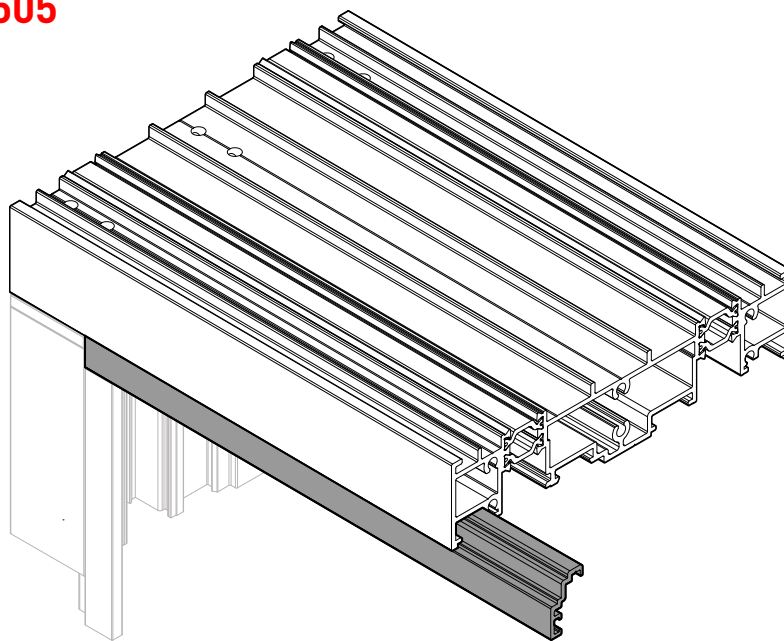
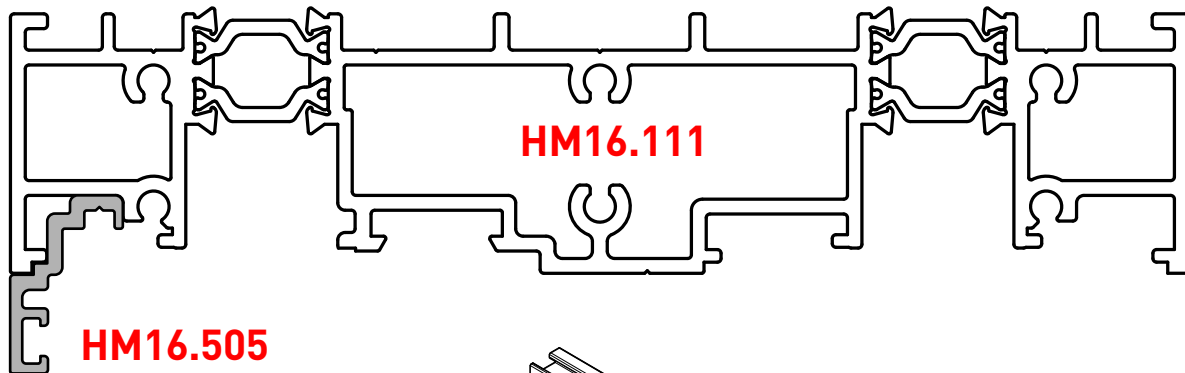



TELAIO

MAIN FRAME

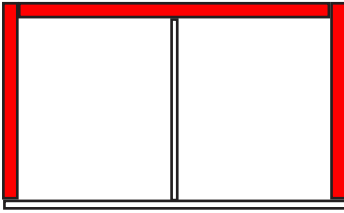

- Installazione Carter di Finitura HX16.504
- Installing Finishing Carter HX16.504

Mobile + Fisso
Sliding + Fixed

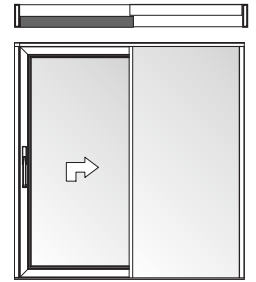

Anta | Sash **90°**

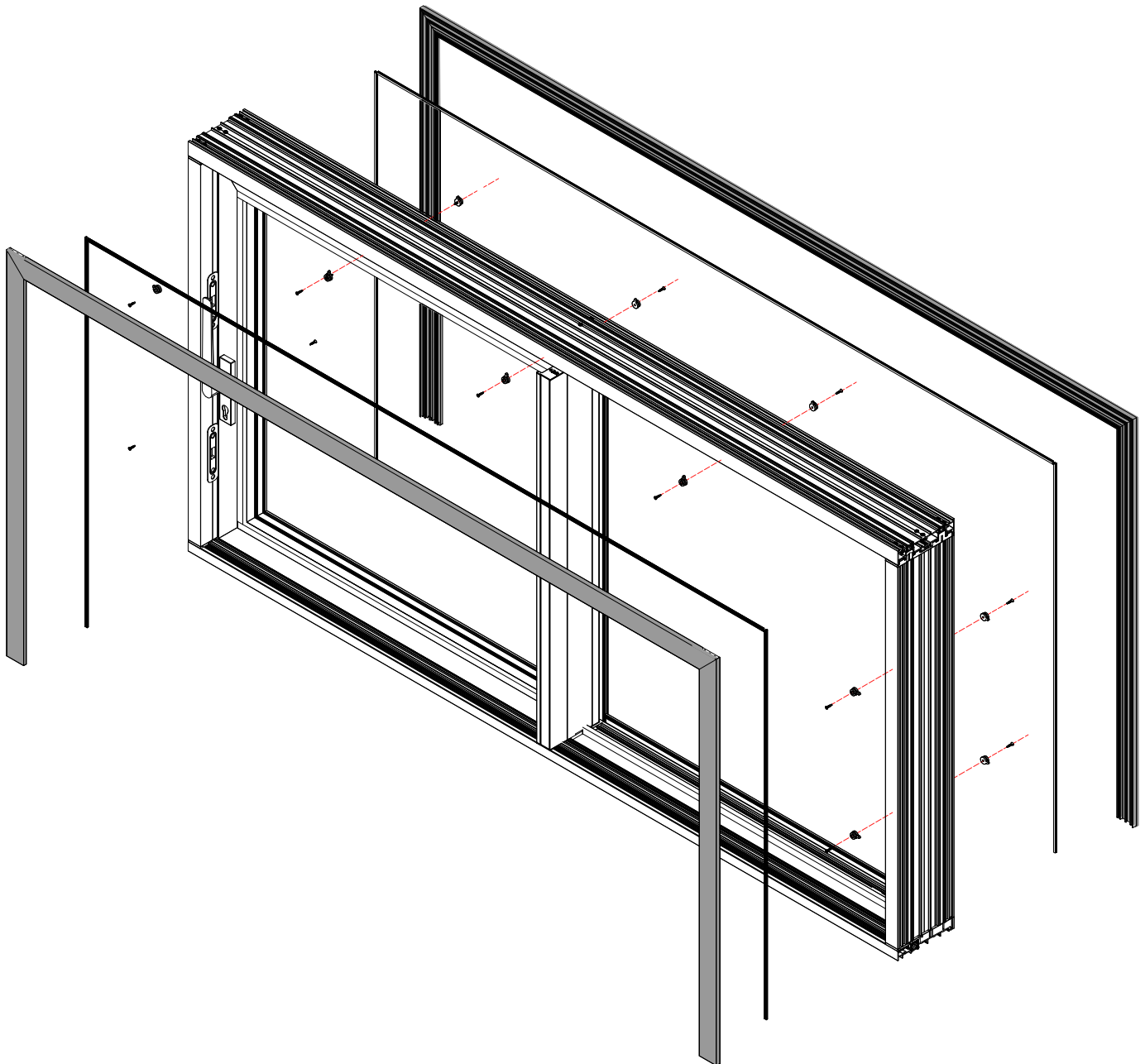

TELAIO
MAIN FRAME

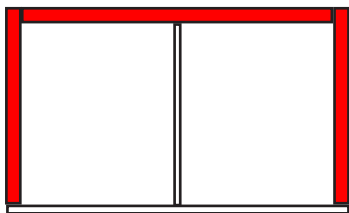

- Installazione Carter di Finitura HX16.504
- Installing Finishing Carter HX16.504



Mobile + Fisso
Sliding + Fixed

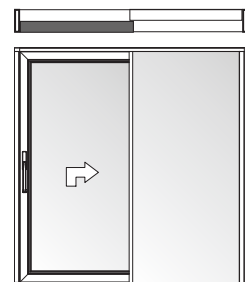

Anta | Sash 90°

VERTICALE
VERTICAL

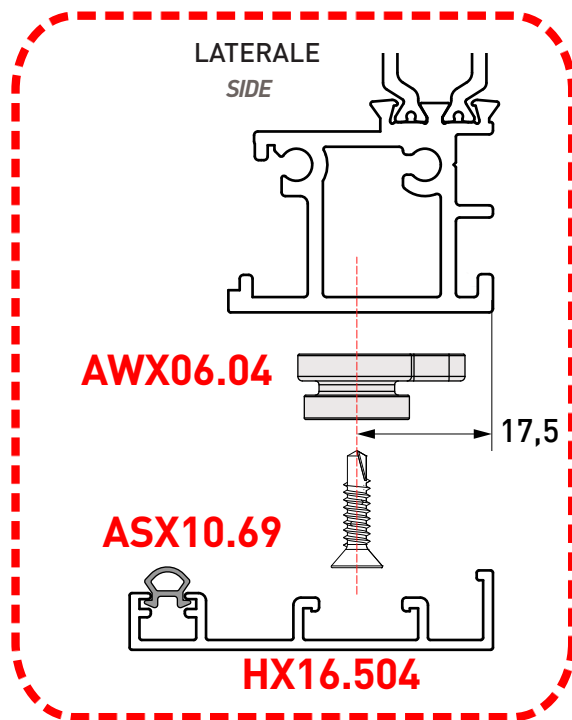
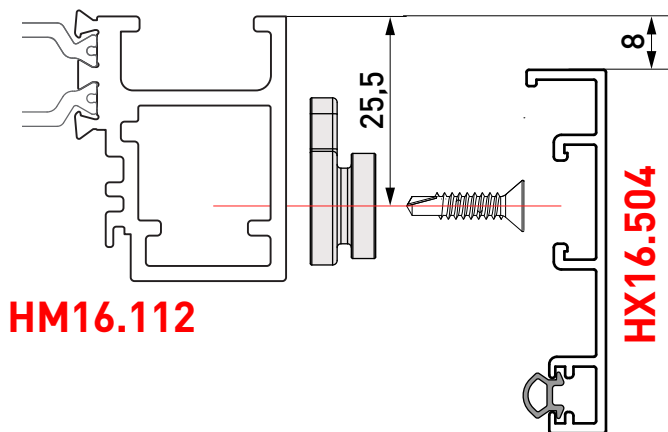
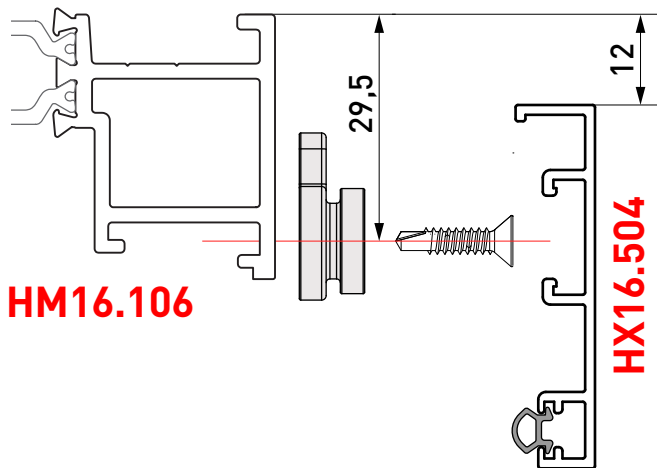
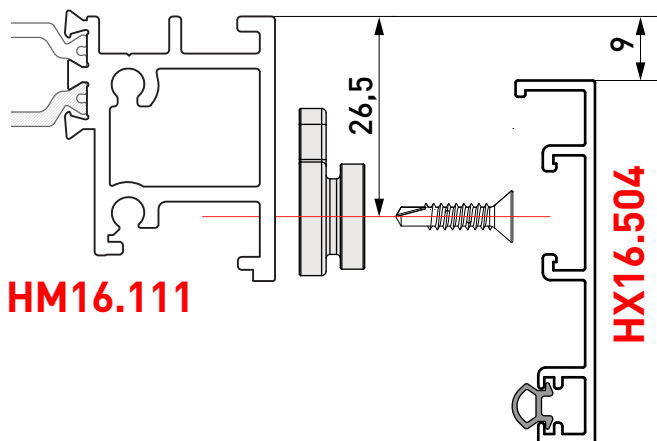



TELAIO
MAIN FRAME

Mobile + Mobile
Sliding + Sliding

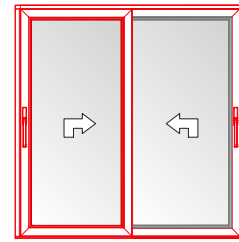

Anta | Sash 45°

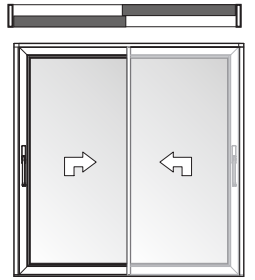

Anta | Sash 90°

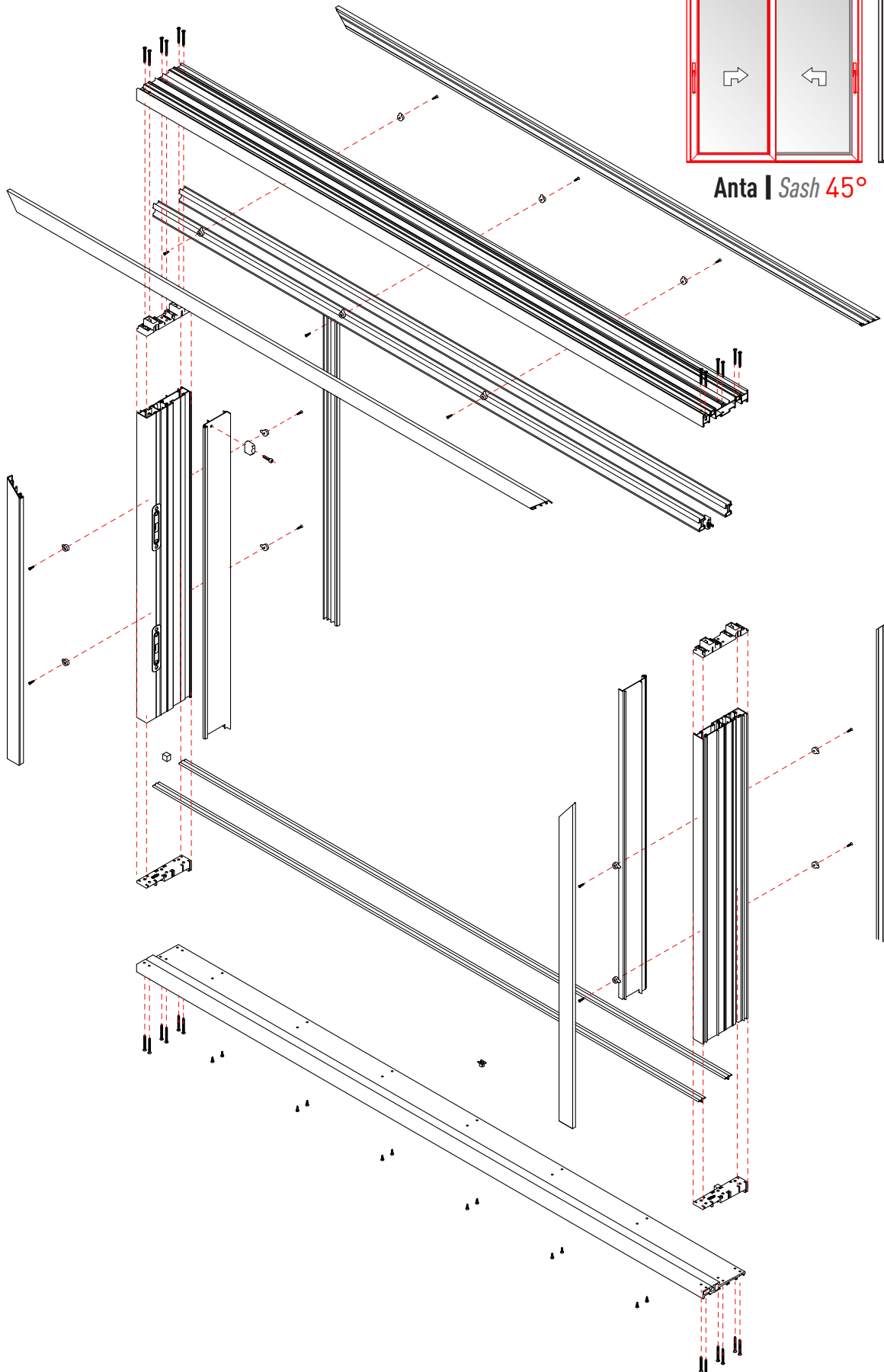

TELAIO

MAIN FRAME



- Lavorazione SOGLIA HX16.107 DRENAGGIO
- Threshold HX16.107 Tooling for DRAINAGE

Mobile + Mobile
Sliding + Sliding

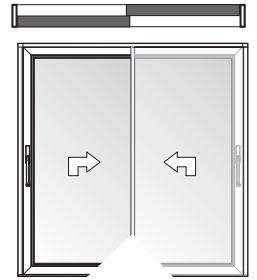
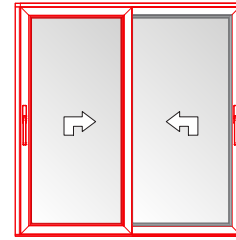

Anta | Sash 45°

90°

BX52

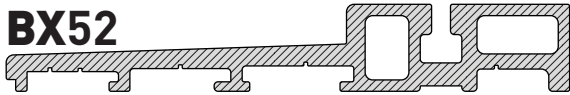

ATTENZIONE Stesse Lavorazioni per la Soglia Termica BX52
IMPORTANT Same Tooling for BX52 Thermic Threshold

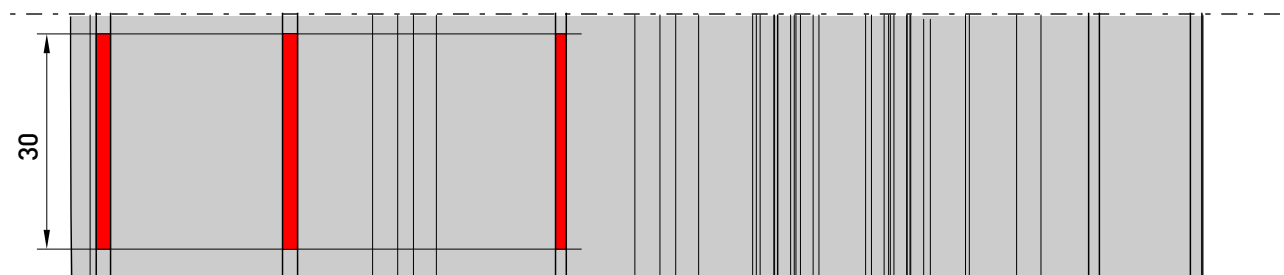
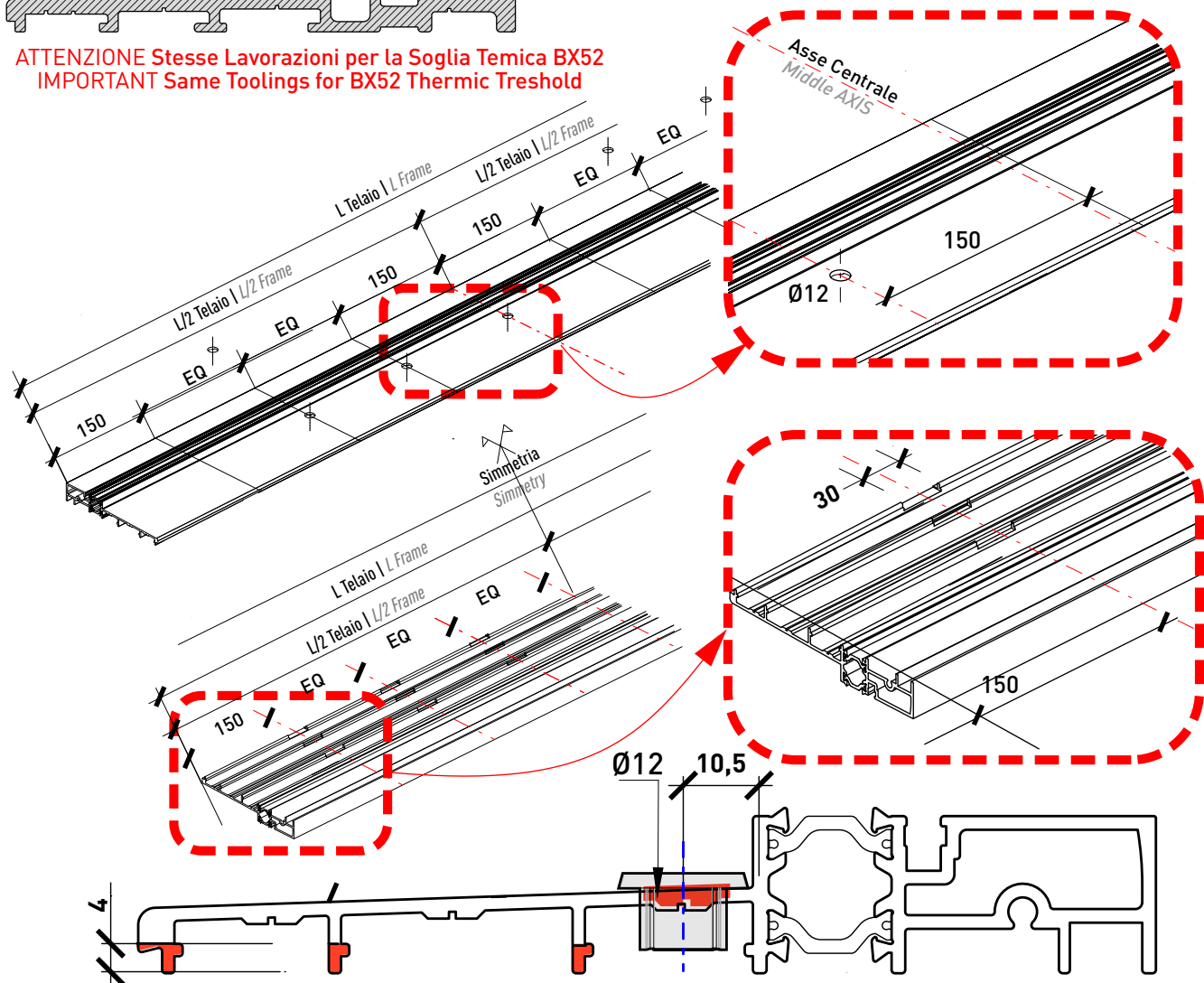

HX16.107

Vista INFERIORE | Bottom View

TELAIO
MAIN FRAME



- Lavorazione SOGLIA HX16.107 Montanti Lateralali
- Treshold HX16.107 Tooling for Lateral Transoms

Mobile + Mobile
Sliding + Sliding

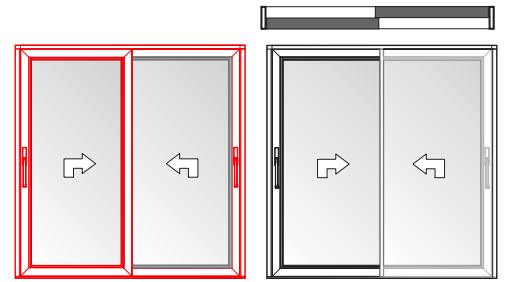

Anta | Sash 45° Anta | Sash 90°

INT

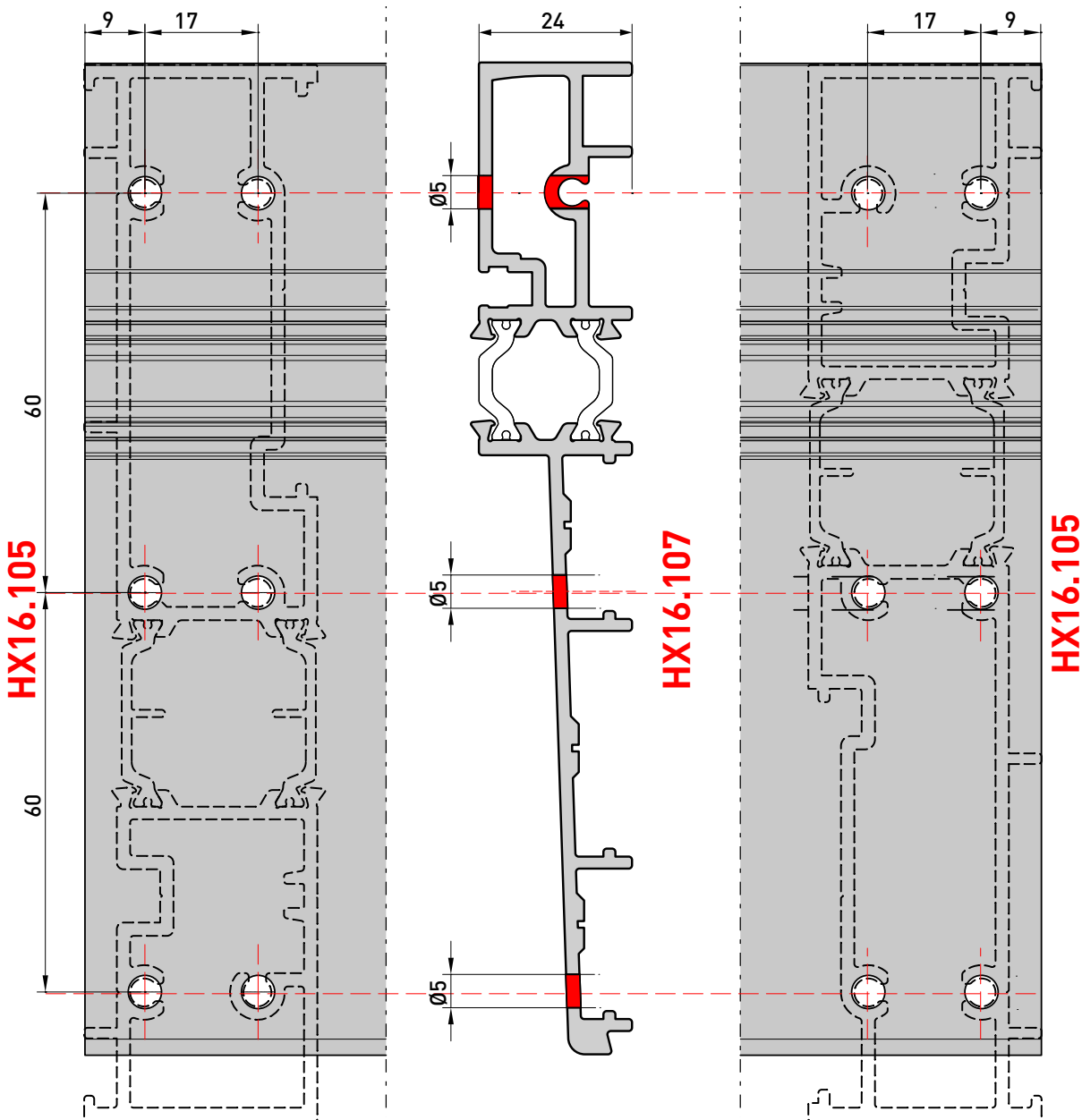

EXT

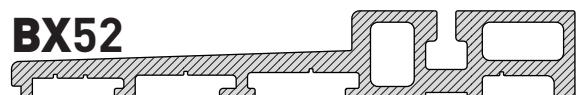

ATTENZIONE Stesse Lavorazioni per la Soglia Temica BX52
IMPORTANT Same Toolings for BX52 Thermic Treshold

TELAIO
MAIN FRAME

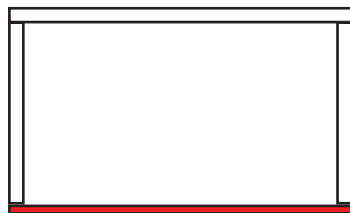

- Drenaggio Soglia HX16.107 + HX16.171
- Water drains - Threshold HX16.107 + HX16.171

Mobile + Mobile
Sliding + Sliding

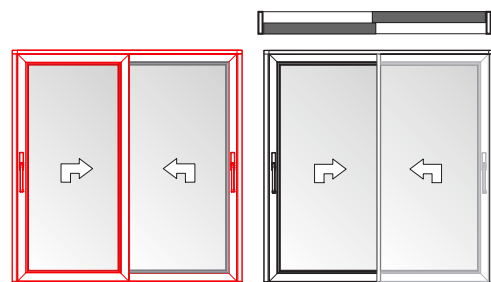

Anta | Sash 45° Anta | Sash 90°

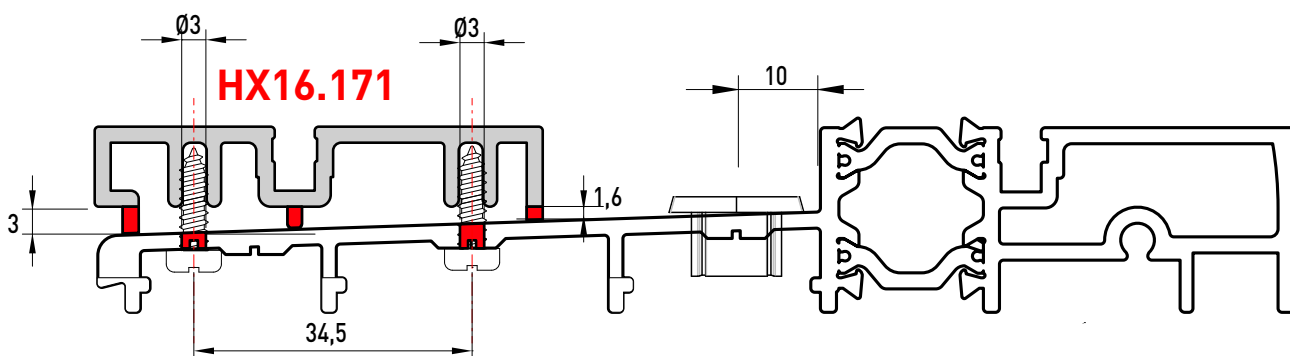

HX16.107

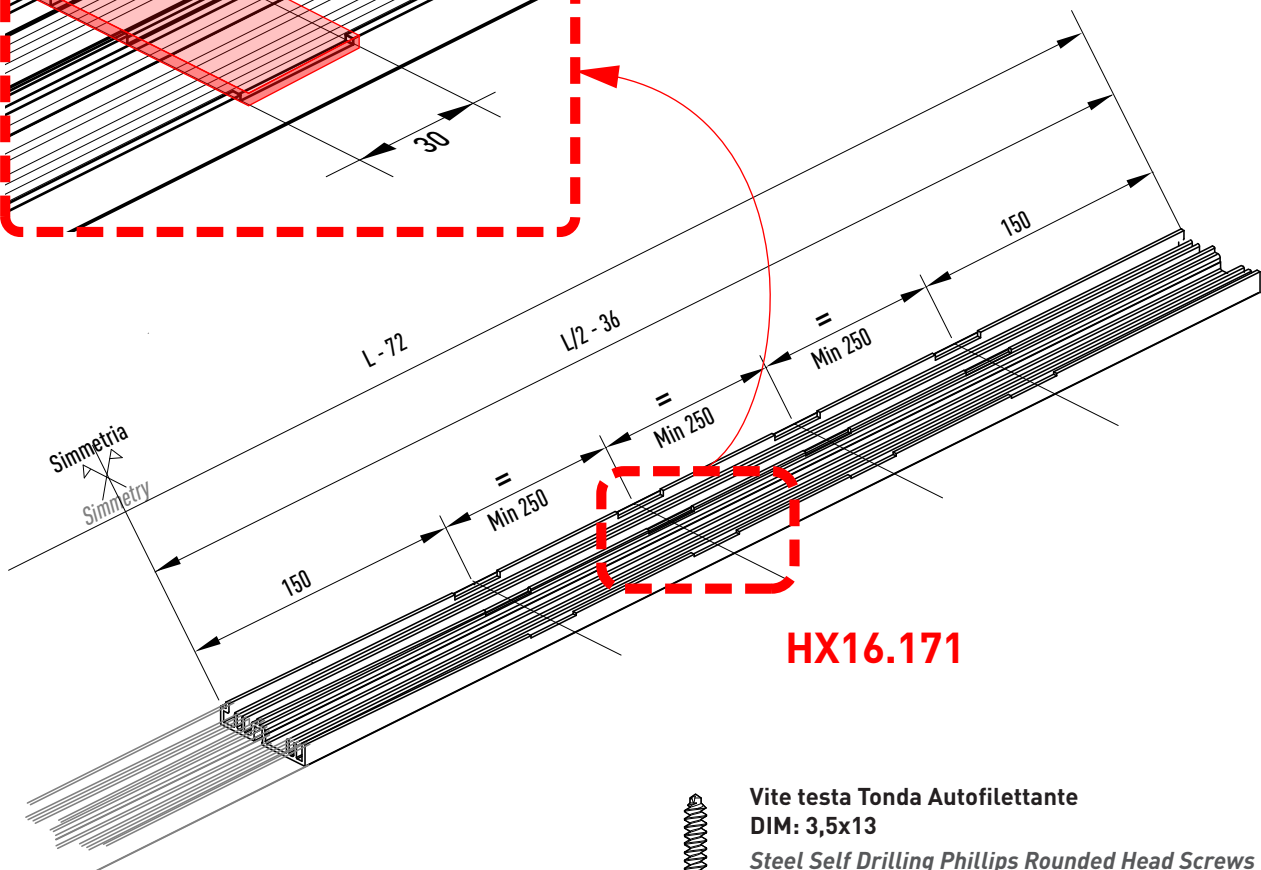
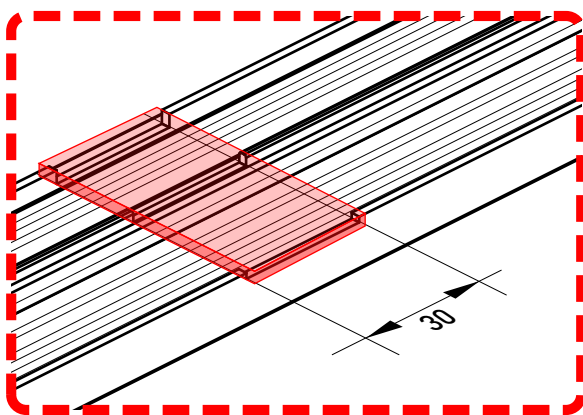

HX16.171

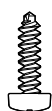

Vite testa Tonda Autofilettante
DIM: 3,5x13
Steel Self Drilling Phillips Rounded Head Screws
DIM: 3,5X13

TELAIO
MAIN FRAME

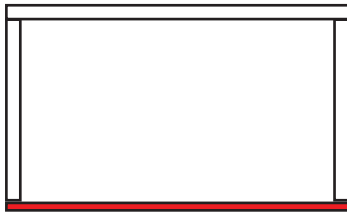

- Piano Calpestio FILOPAVIMENTO HX16.107 + HX16.171
- FLOORLEVEL Threshold Walking Plane HX16.107 + HX16.171

Mobile + Mobile
Sliding + Sliding

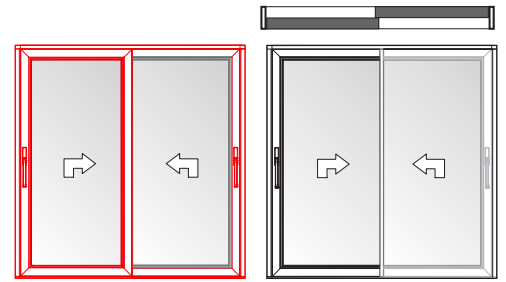

Anta | Sash 45° Anta | Sash 90°

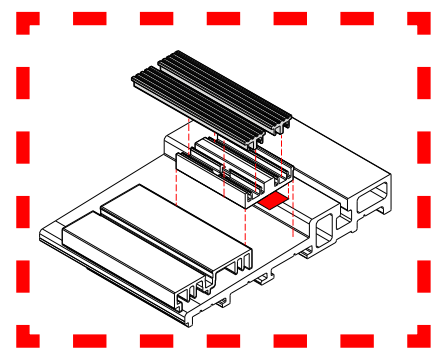
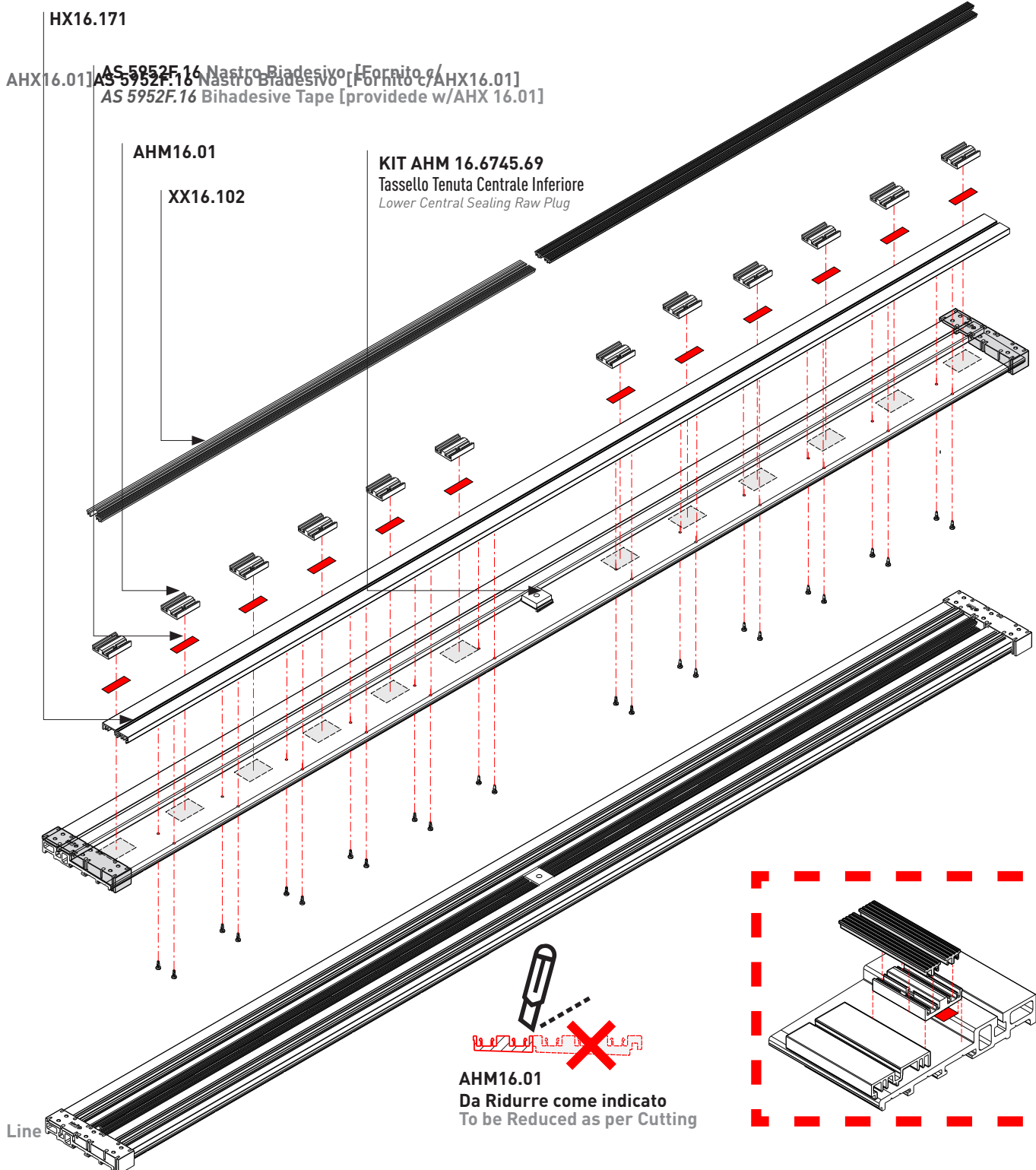

TELAIO
MAIN FRAME

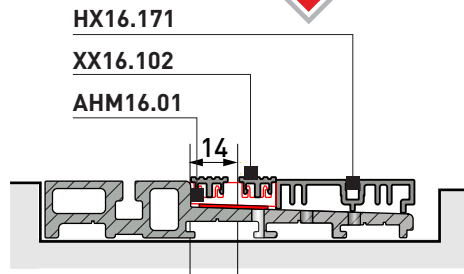

Mobile + Mobile
Sliding + Sliding

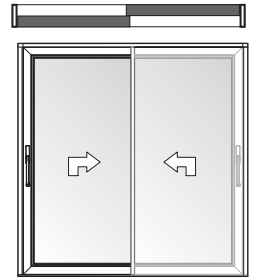
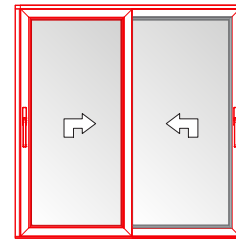

Anta | Sash 45°

Anta | Sash 90°

- Drenaggio Soglia FILOPAVIMENTO
AHM 16.01 + HX16.171
- FLOORLEVEL Threshold Drainage AHM
16.01 + HX16.171

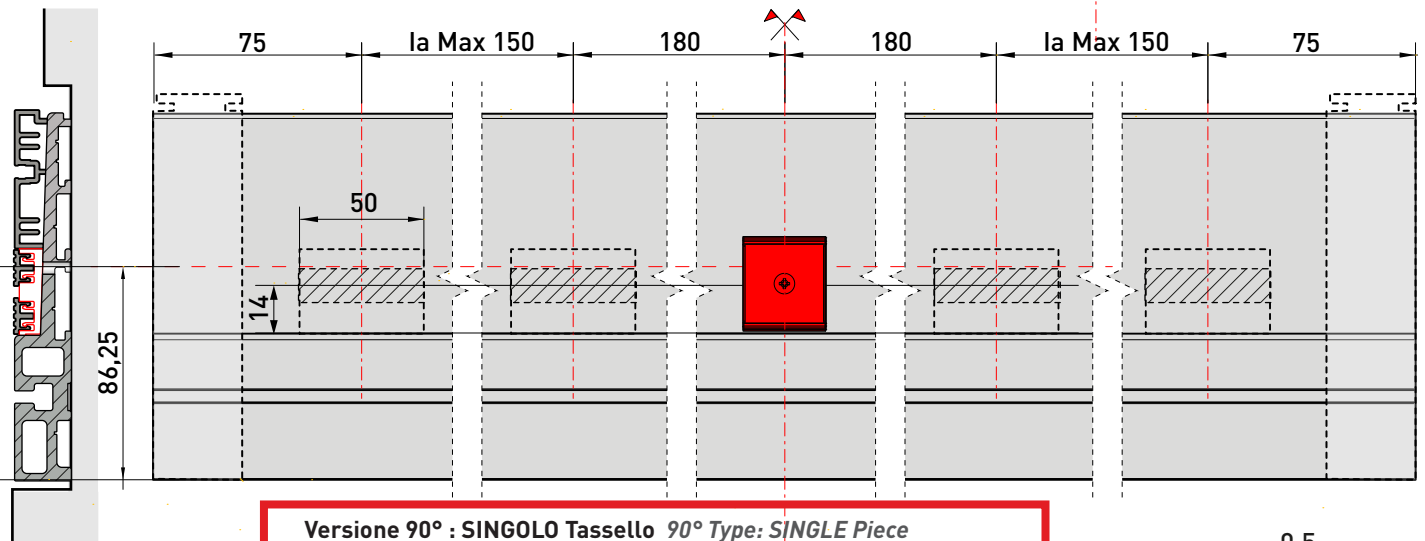
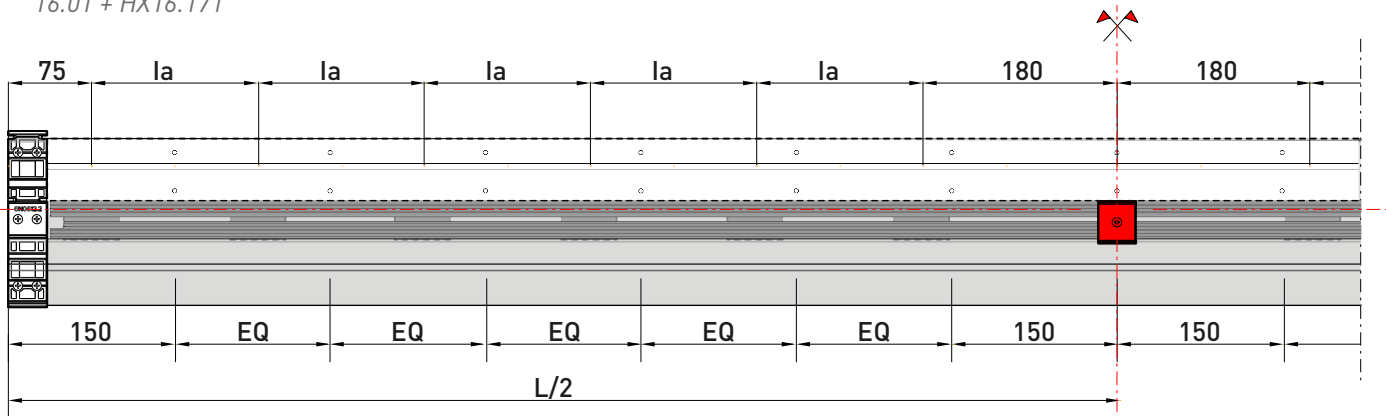

Versione 90° : SINGOLO Tassello 90° Type: SINGLE Piece

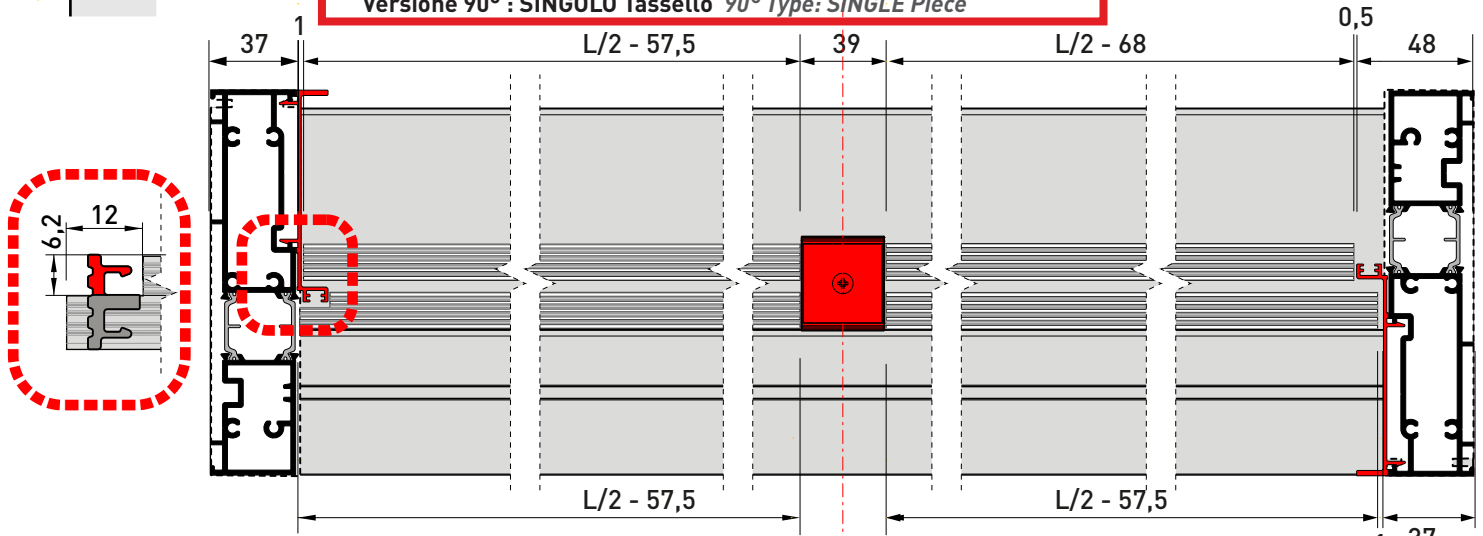

TELAIO
MAIN FRAME

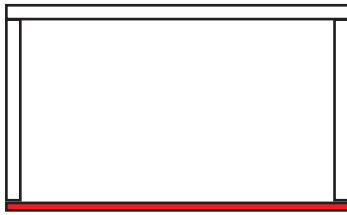

- Sistema FILOPAVIMENTO HX16.107 + HX16.171
- FLOORLEVEL Threshold System HX16.107 + HX16.171

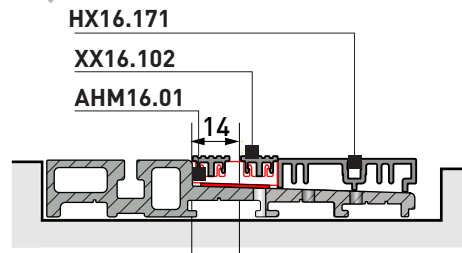

Mobile + Mobile
Sliding + Sliding

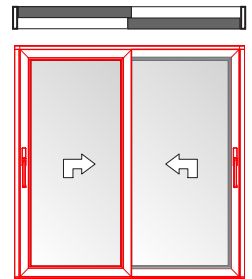

Anta | Sash 45°

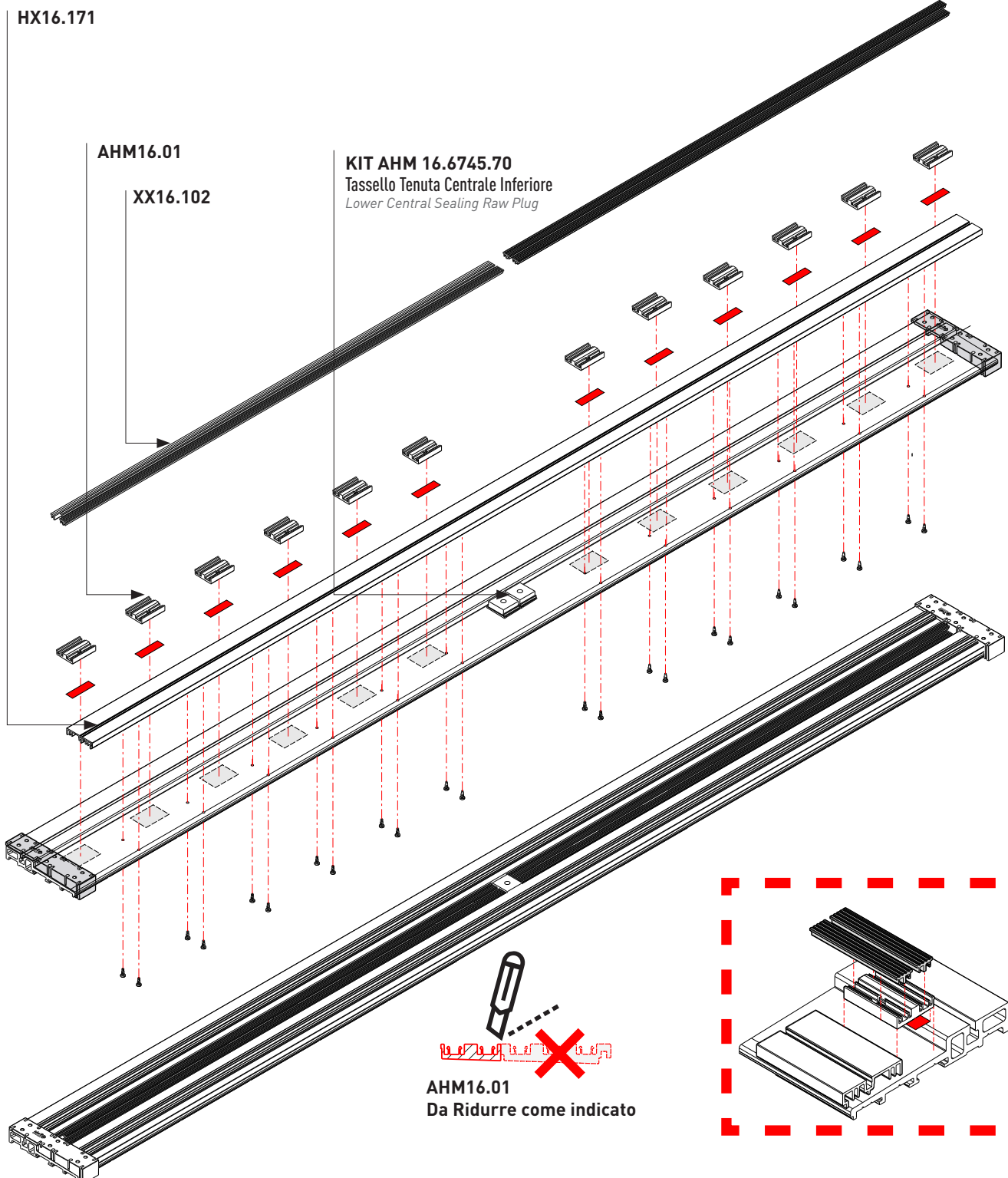

TELAIO
MAIN FRAME



- Soglia FILOPAVIMENTO AHM 16.01
- FLOORLEVEL Threshold AHM 16.01

Mobile + Mobile
Sliding + Sliding

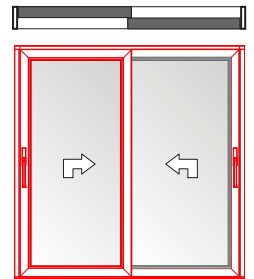

Anta | Sash 45°

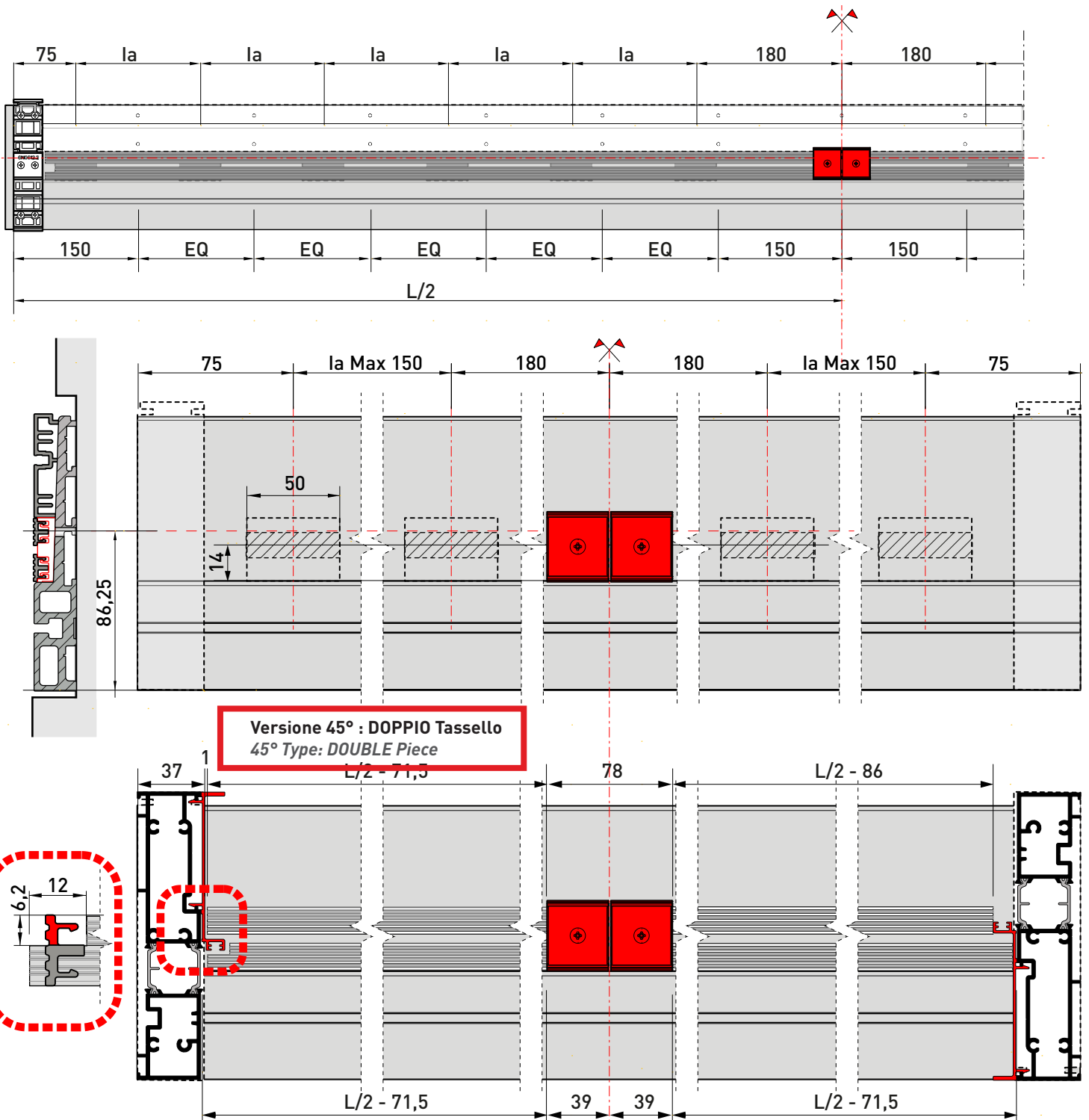



Tassello Tenuta Centrale Inferiore

TELAIO
MAIN FRAME

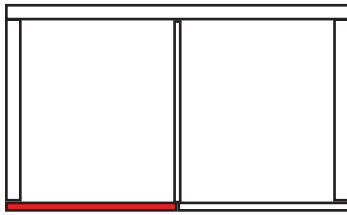

Mobile + Fisso
Sliding + Fixed

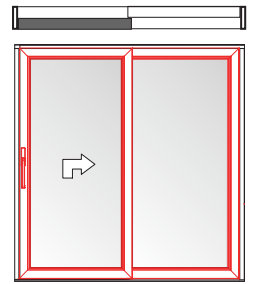

Anta | Sash 45°

- Installazione Tappo di Tenuta Centrale Lato ESTERNO [KIT 16.6745.76]
- Central Sealing Plug Installation EXTERNAL Side [KIT 16.6745.76]

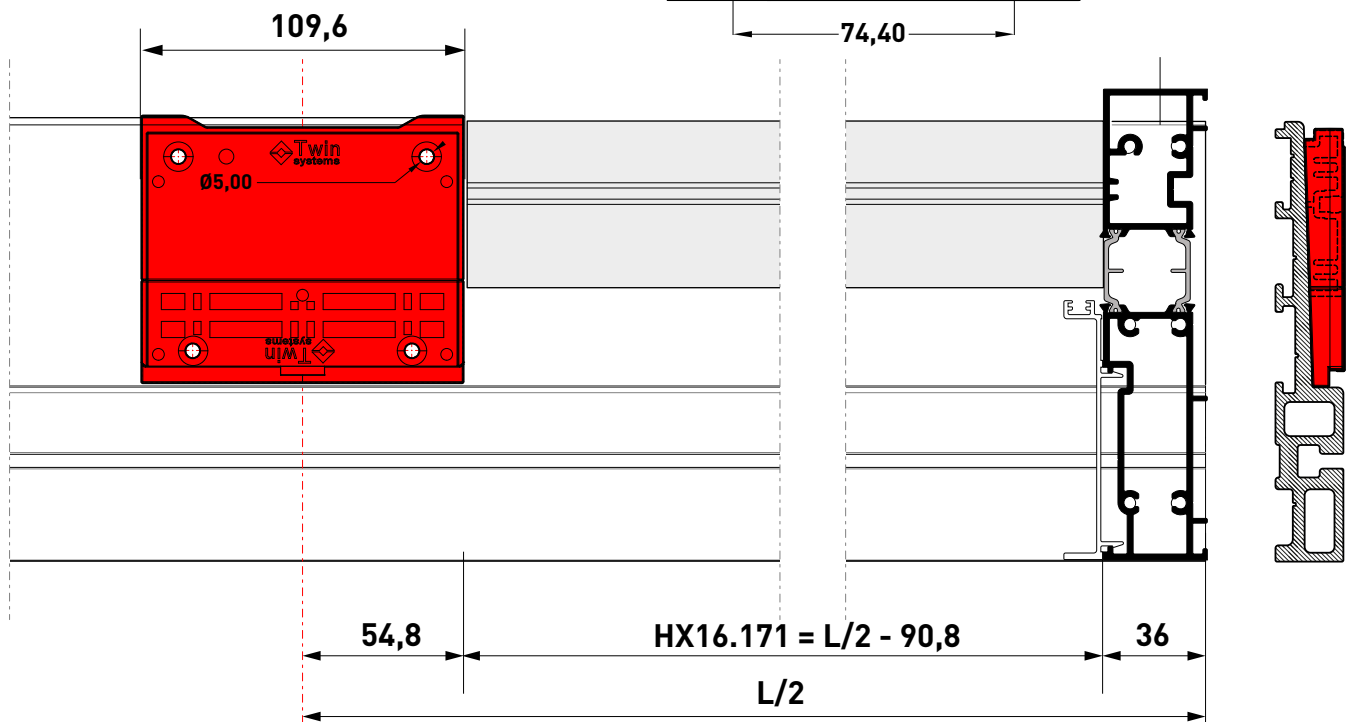
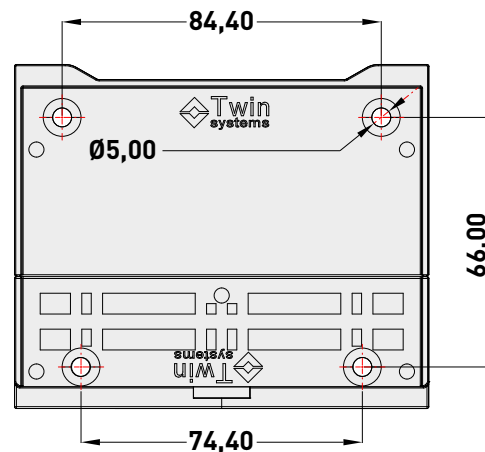
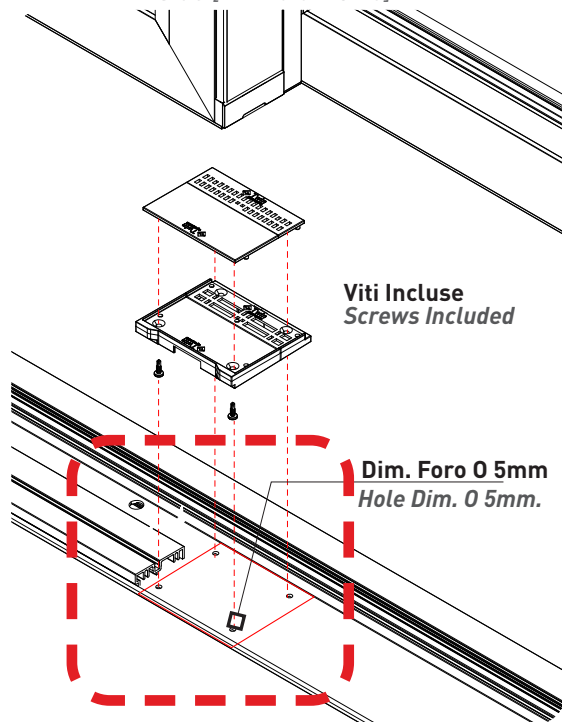
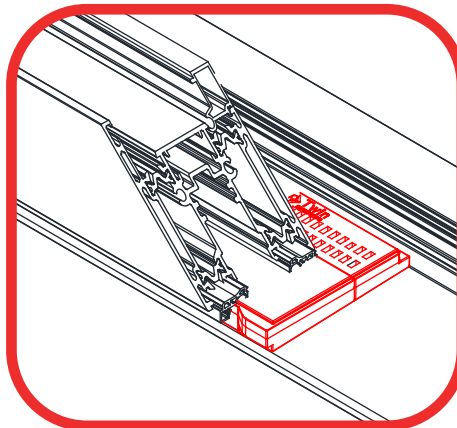

ANTA

SASH



- Soglia FILOPAVIMENTO KIT 16.6745.76
- FLOORLEVEL Threshold KIT 16.6745.76

Mobile + Fisso
Sliding + Fixed

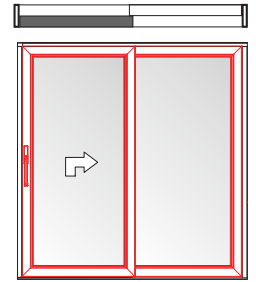

Anta | Sash 45°



TELAIO
MAIN FRAME



- Lavorazione Travrso Superiore HX16.106
- Tooling Upper Transom HX16.106

Mobile + Mobile
Sliding + Sliding

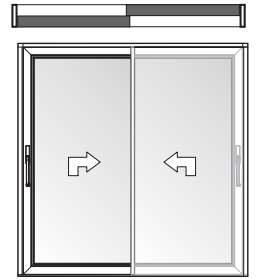
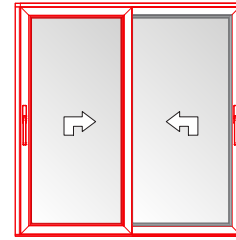

Anta | Sash 45°

Anta | Sash 90°

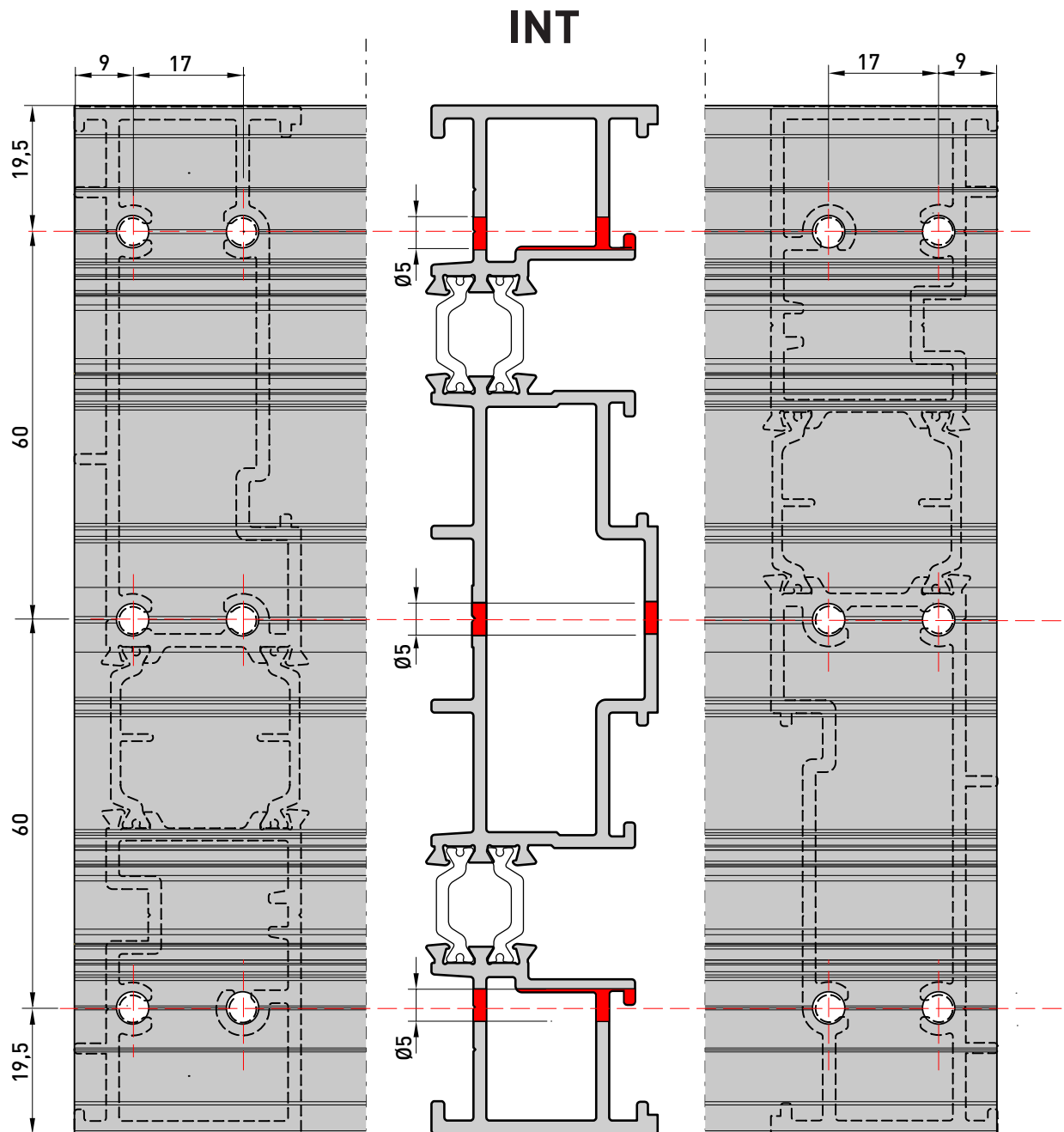

HX16.105

HX16.106

HX16.105

EXT

TELAIO
MAIN FRAME

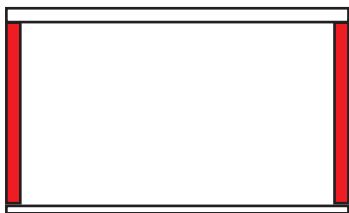

- Lavorazione Montante Laterale HX16.105
- Transom HX16.105 Tooling

Mobile + Mobile
Sliding + Sliding

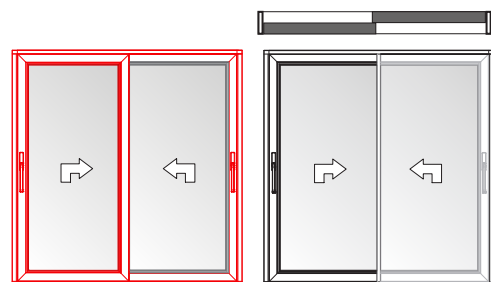

Anta | Sash 45°

Anta | Sash 90°

CODICE	L Asta	H1	H2	H3
HM16.6732.2	1305	212	582	-
HM16.6732.3	1900	212	1082	-
HM16.6732.4	2500	212	1678	-
HM16.6732.5	2800	212	1210	2110
HM16.6732.6	3300	212	1410	2510
HM16.6732.7	3800	212	1410	2510

NB. Lavorazioni su Anta e H Ganci Tav G36

NB. Sash Tooling and Hook Height Position see Tab. G37

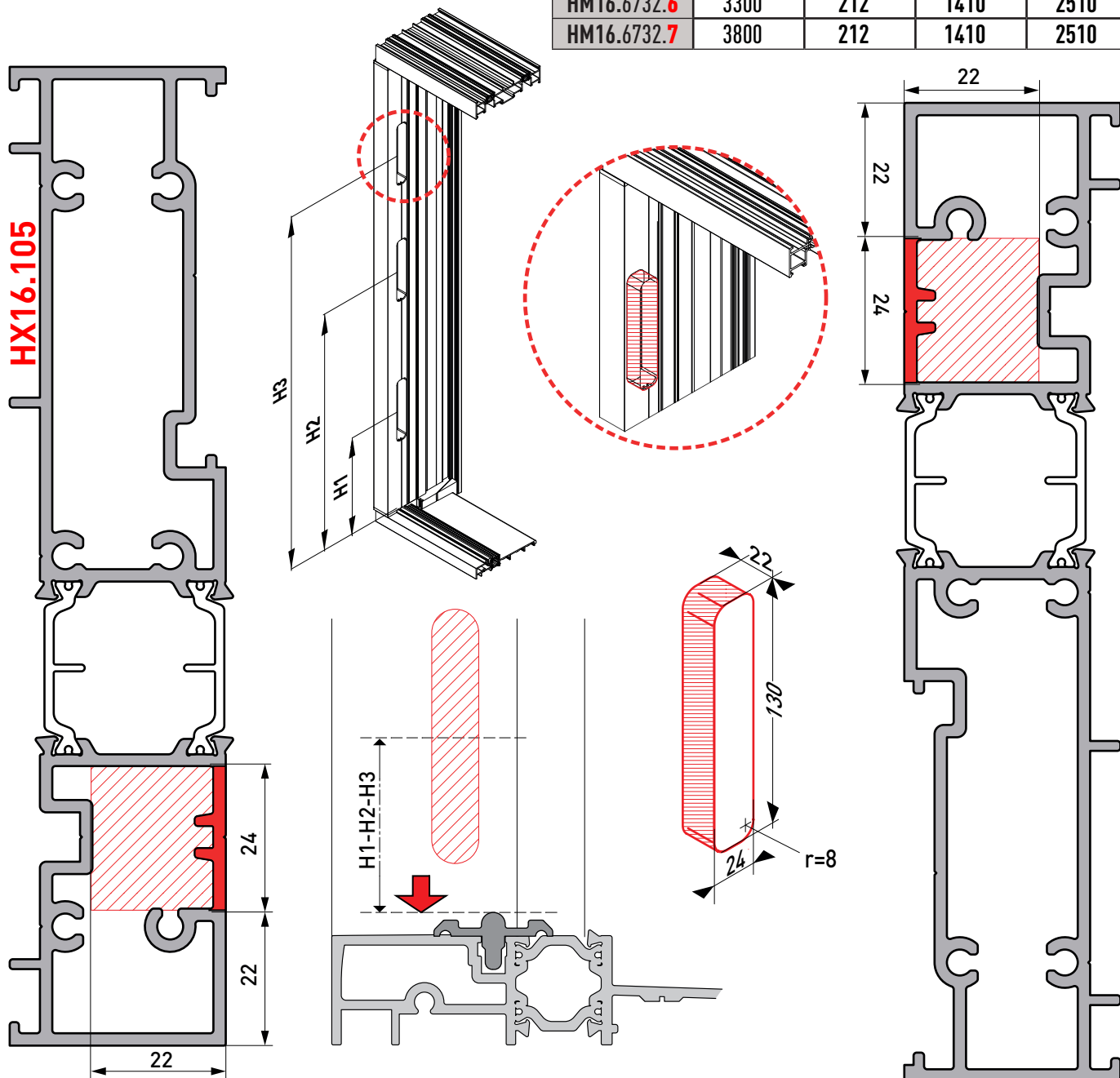



TELAIO
MAIN FRAME



- Lavorazione Carter Laterale HM16.508 ESTERNO
- Tooling for Lateral Carter HM16.508 EXTERNAL

Mobile + Mobile
Sliding + Sliding

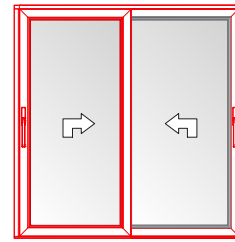

Anta | Sash 45°

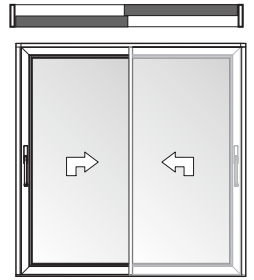

Anta | Sash 90°

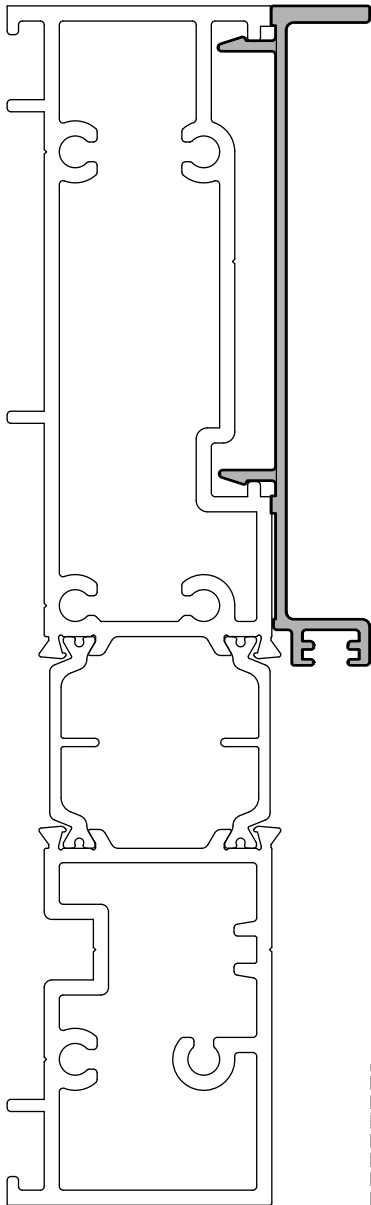
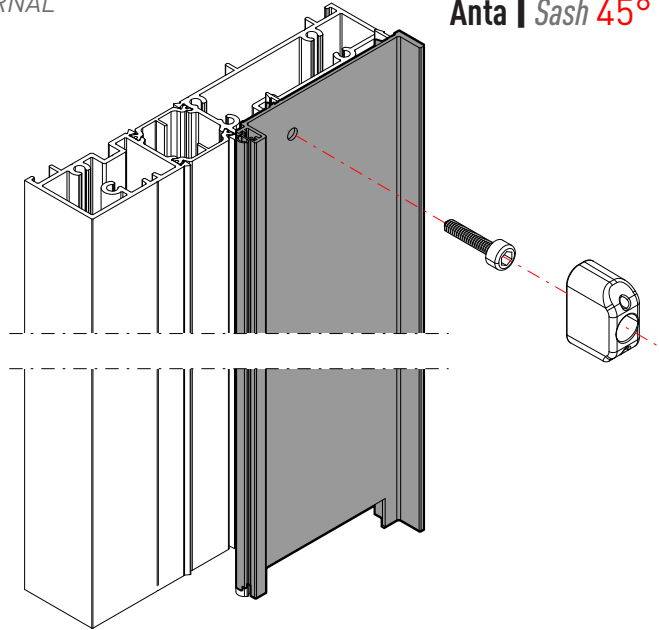

HX16.105

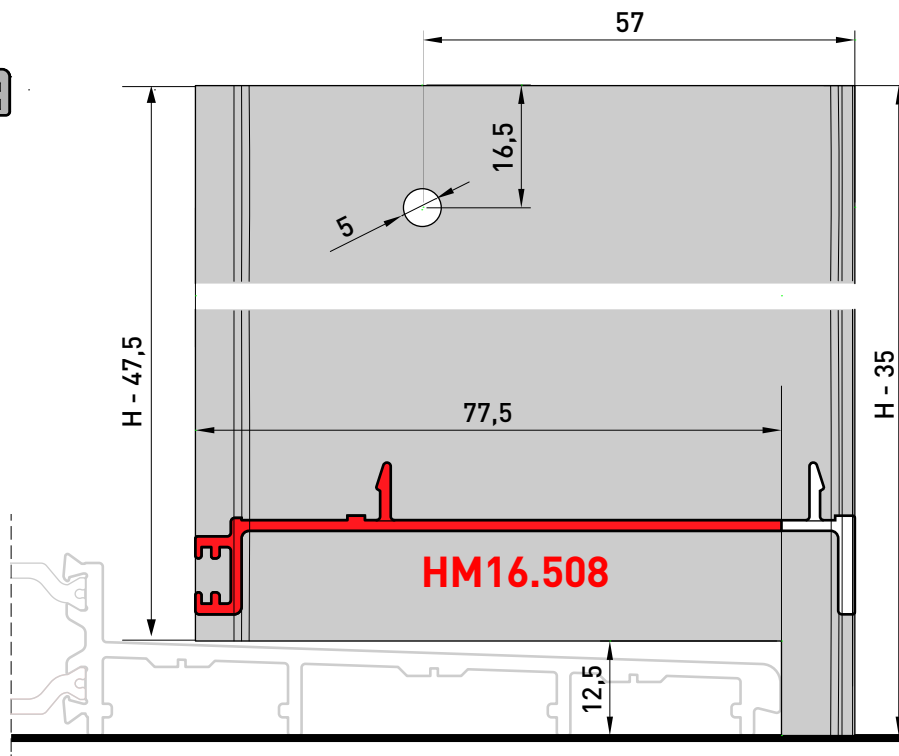



TELAIO
MAIN FRAME

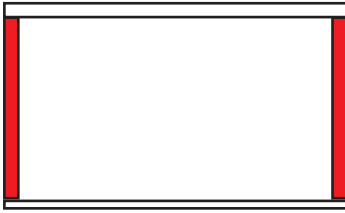

- Inserimento Spugnetta Montante Laterale
• *Sponge Inserting at Side Mullion*

Mobile + Mobile
Sliding + Sliding

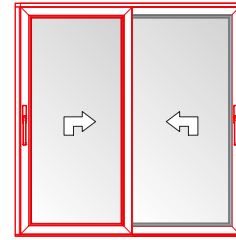

Anta | Sash **45°**

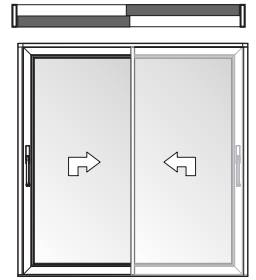

Anta | Sash **90°**

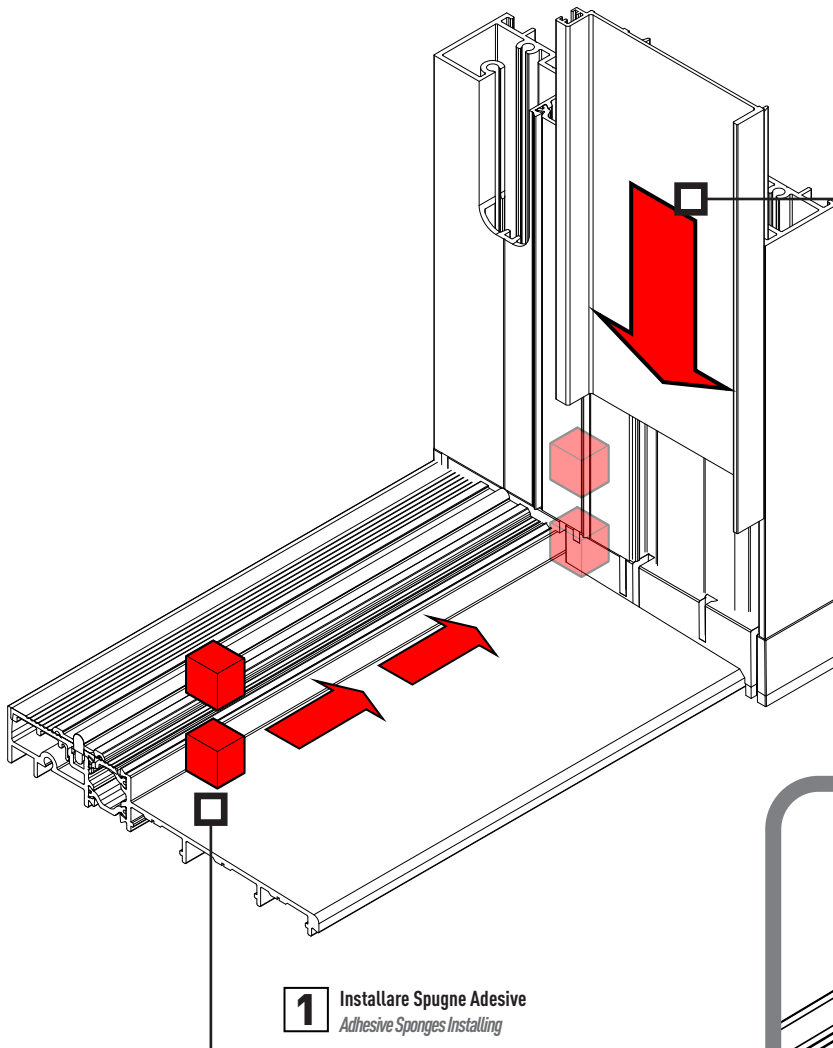

1 Installare Spugne Adesive
Adhesive Sponges Installing

2 Posizionare Profilo HX16.105 e comprimere le Spugne per un corretto Funzionamento
Place Profile HM16.XXX and compress the Sponges for correct operation

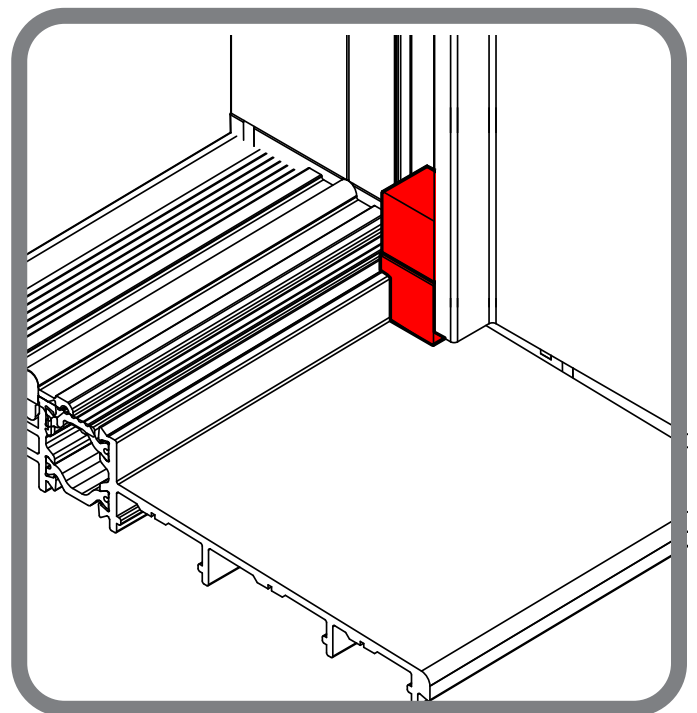

TELAIO

MAIN FRAME

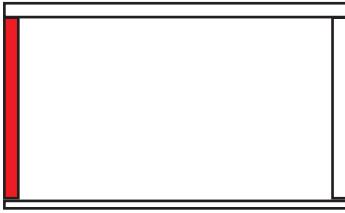

- Lavorazione Carter Laterale HM16.508 INTERNO
- Tooling for Lateral Carter HM16.508 INTERNAL

Mobile + Mobile
Sliding + Sliding

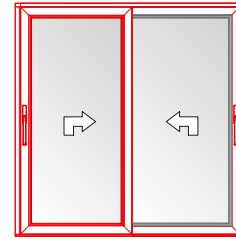

Anta | Sash **45°**

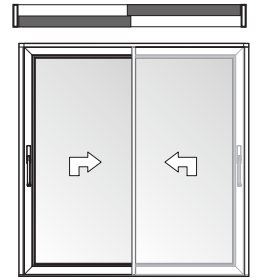

Anta | Sash **90°**

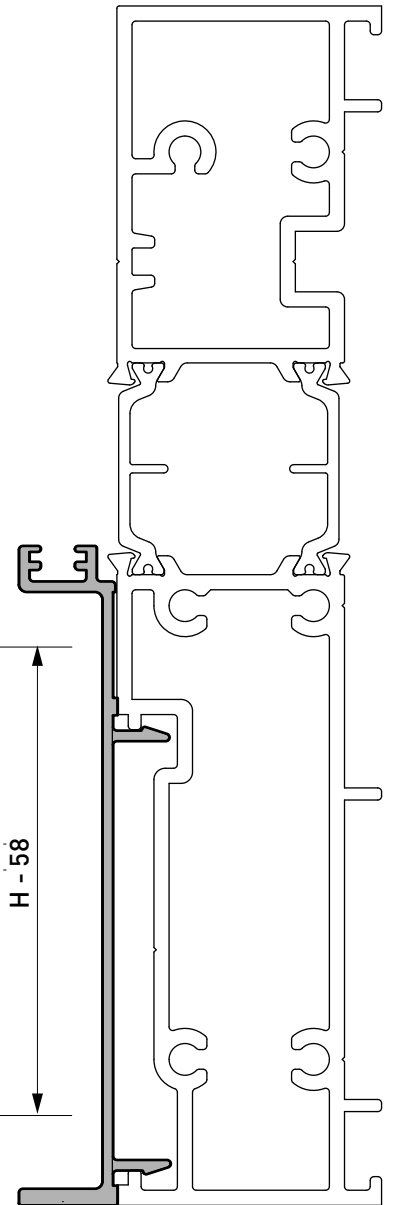
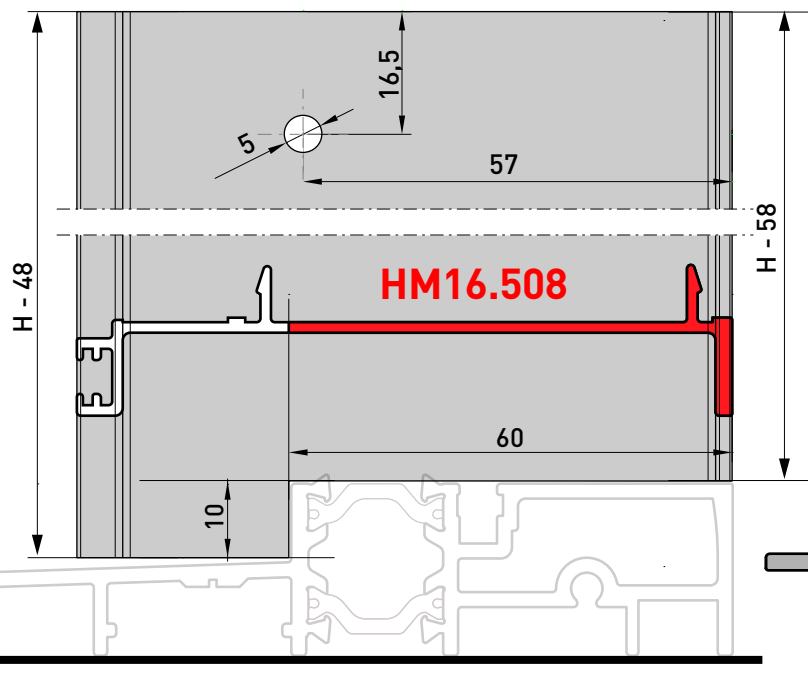
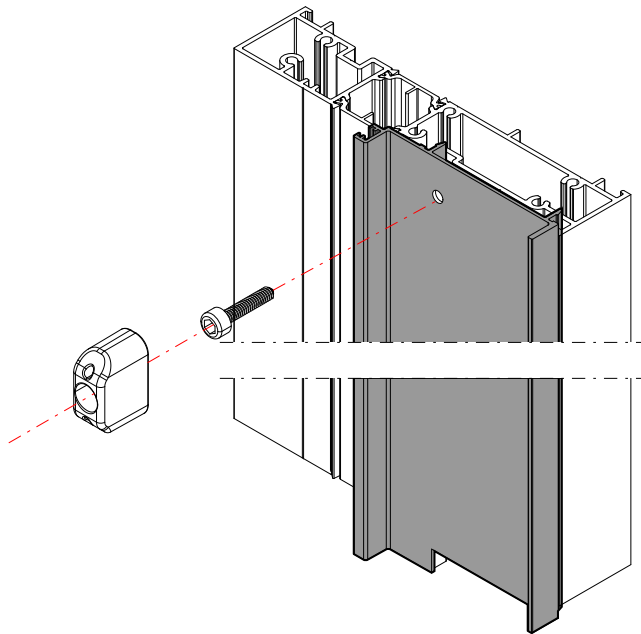

HX16.105



ANTA

SASH

- ESPLOSO ASSONOMETRICO
- AXONOMETRIC EXPLODED VIEW

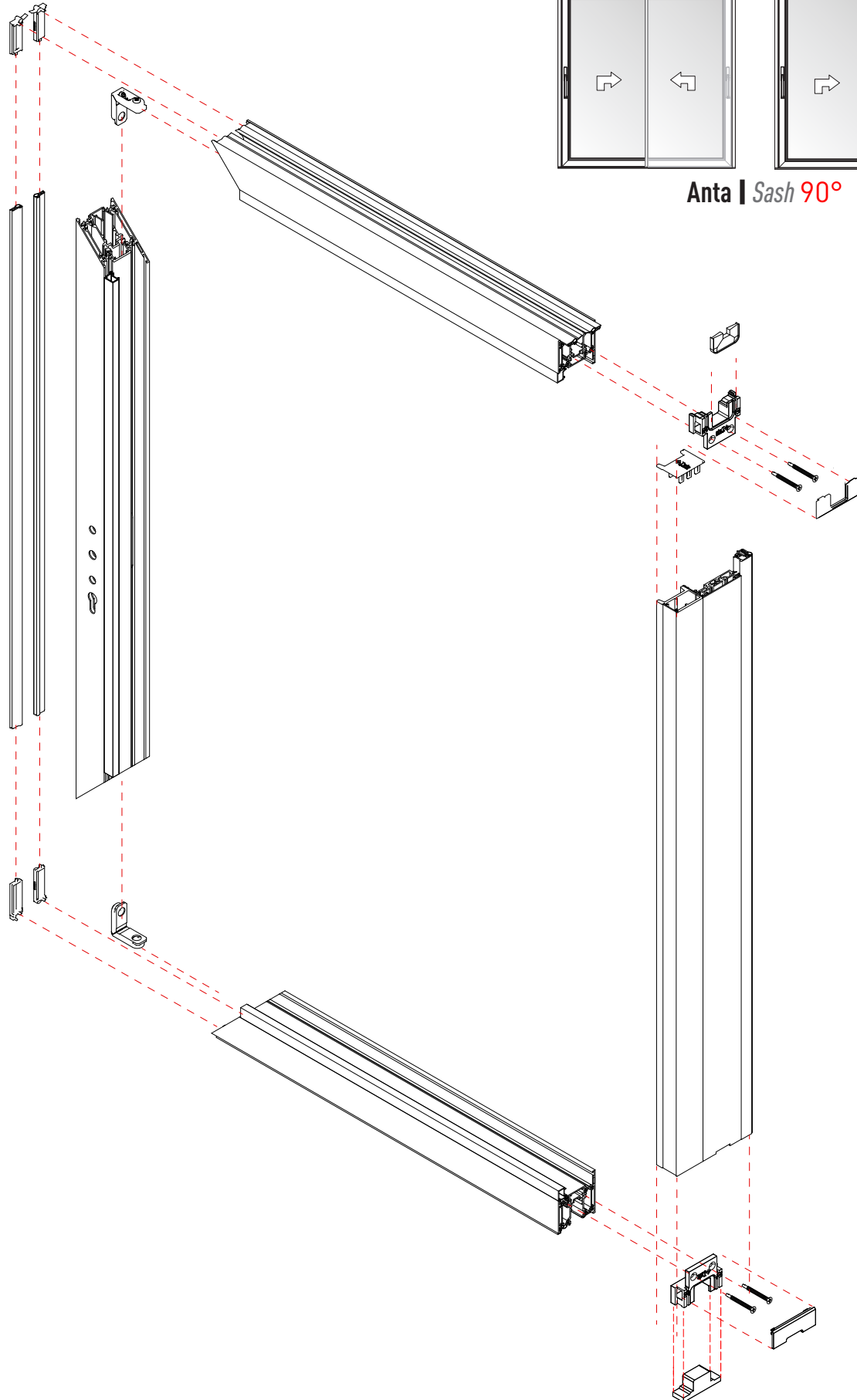

Mobile + Mobile
Sliding + Sliding

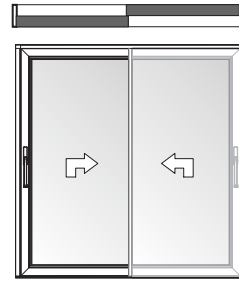

Mobile + Vetrata
Sliding + Glaze

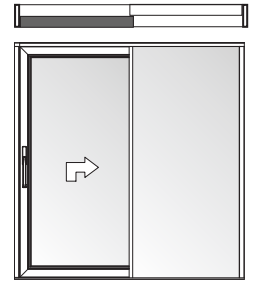

Anta | Sash 90°

ANTA
SASH

2 Scorrevoli
2 Sliding

1 Scorrevole
Sliding

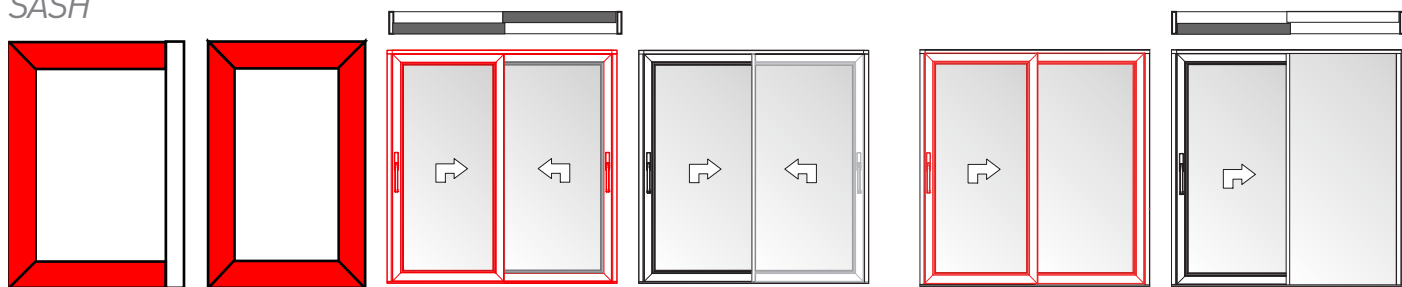

- Lavorazioni Squadretta ACX50. Anta | Sash 45° Anta | Sash 90° Anta | Sash 45° Anta | Sash 90°
SQ su HM16.204
- Tooling for Coner Joint
ACX50.SQ on MX16.204

Cod. Attrezzatura RX07001/B

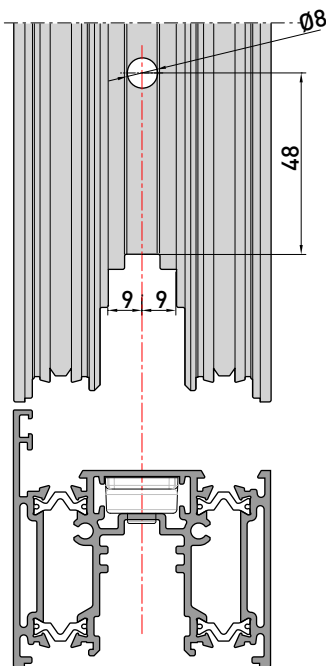
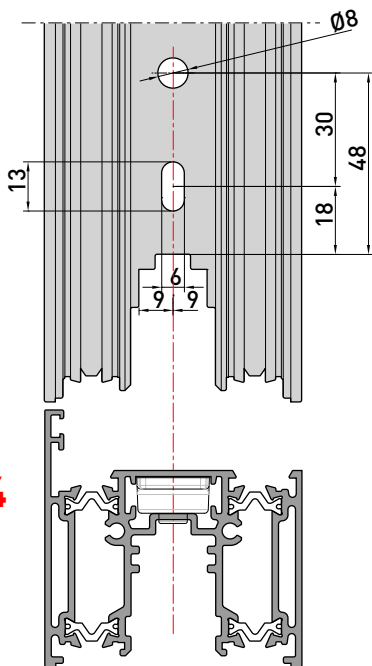
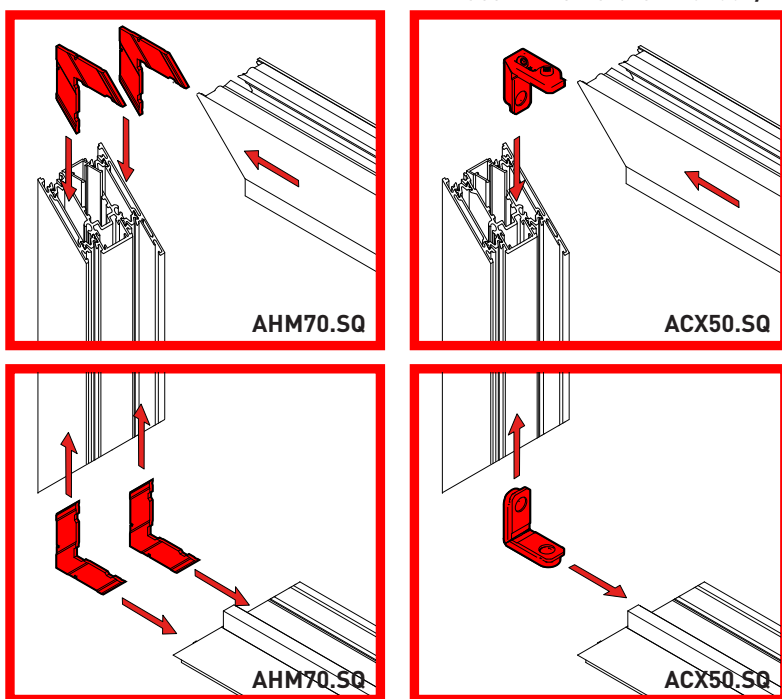

HM16.204

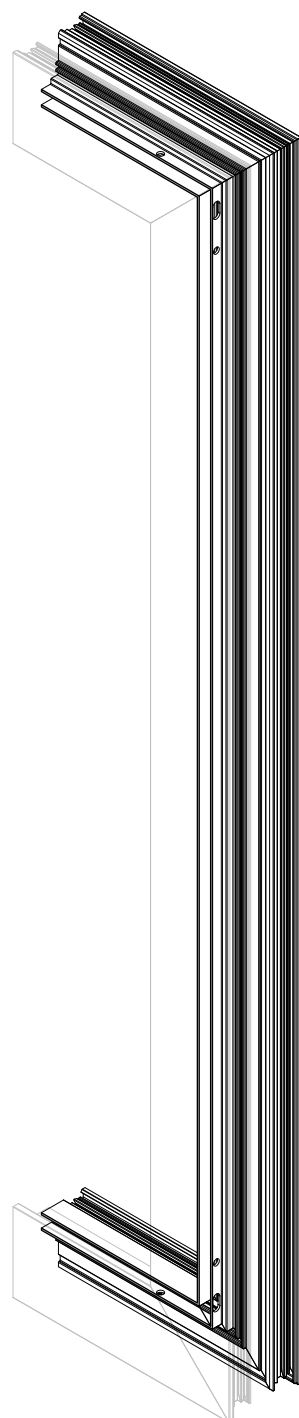

ANTA
SASH

2 Scorrevoli
2 Sliding

1 Scorrevole
Sliding

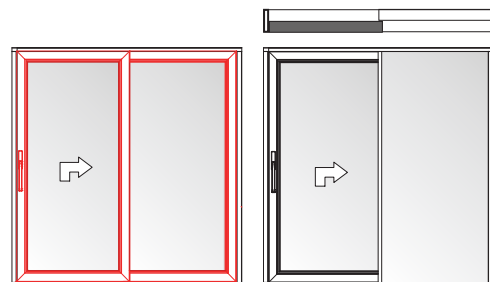
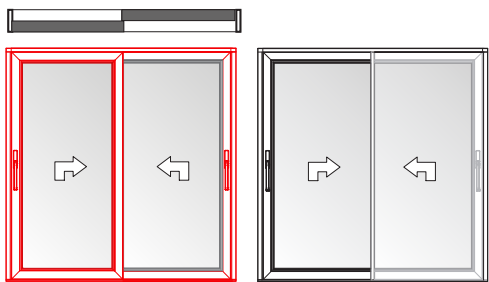
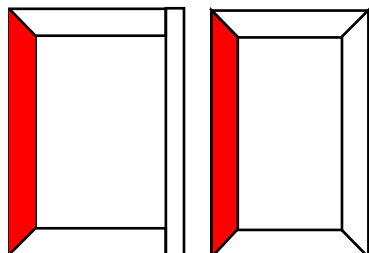

- Lavorazioni Maniglia
- Tooling Handle

Anta | Sash 45°

Anta | Sash 90°

Anta | Sash 45°

Anta | Sash 90°

INTERNO
Interior

ESTERNO
Exterior

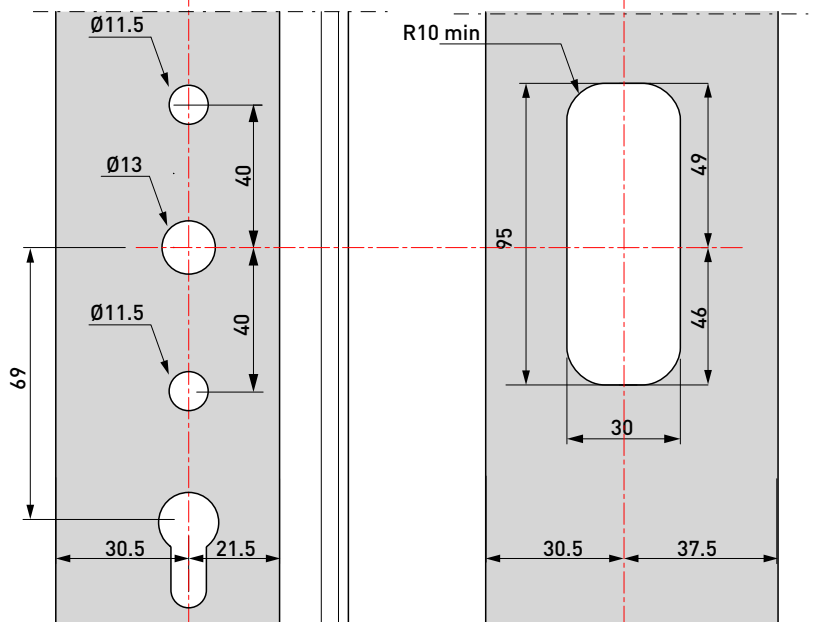

HM16.204

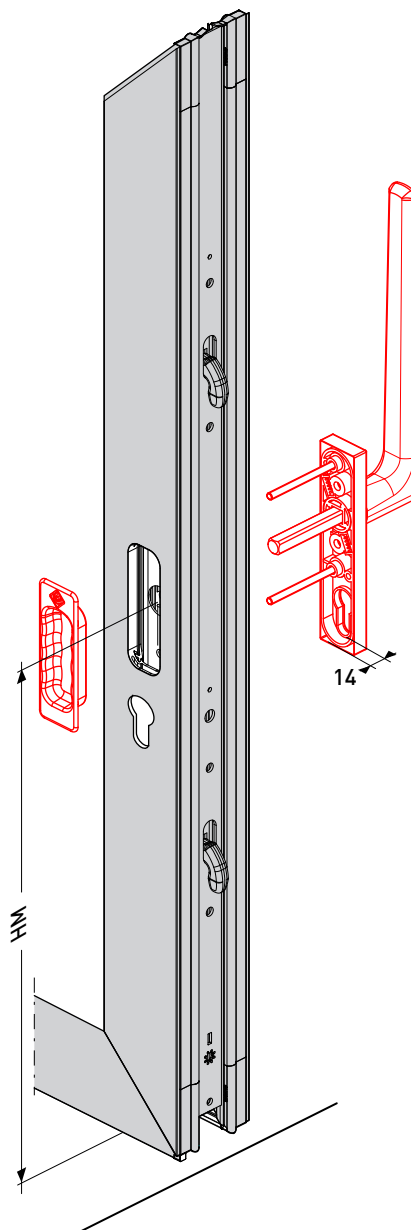
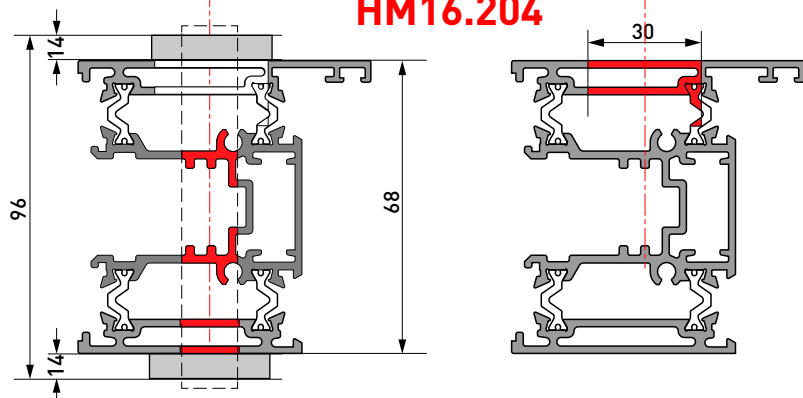

NB. Per verificare l'Altezza dei Riscontri Ganci vedi Tav G07
NB. To Check Hook Striker Height Position see Tab. G07

ITALIA

- AHX3080.20
- AHX3080.25

KARMA

- AHM3081.20
- AHM3081.35

ANTA

SASH



- Lavorazione Montante Centrale BX48
- Tooling for MIDDLE Mullion BX48

Mobile + Mobile
Sliding + Sliding



Mobile + Vetrata
Sliding + Glaze

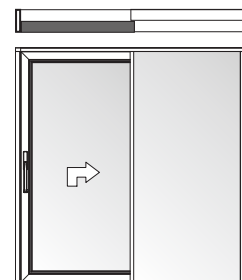

Anta | Sash 90°

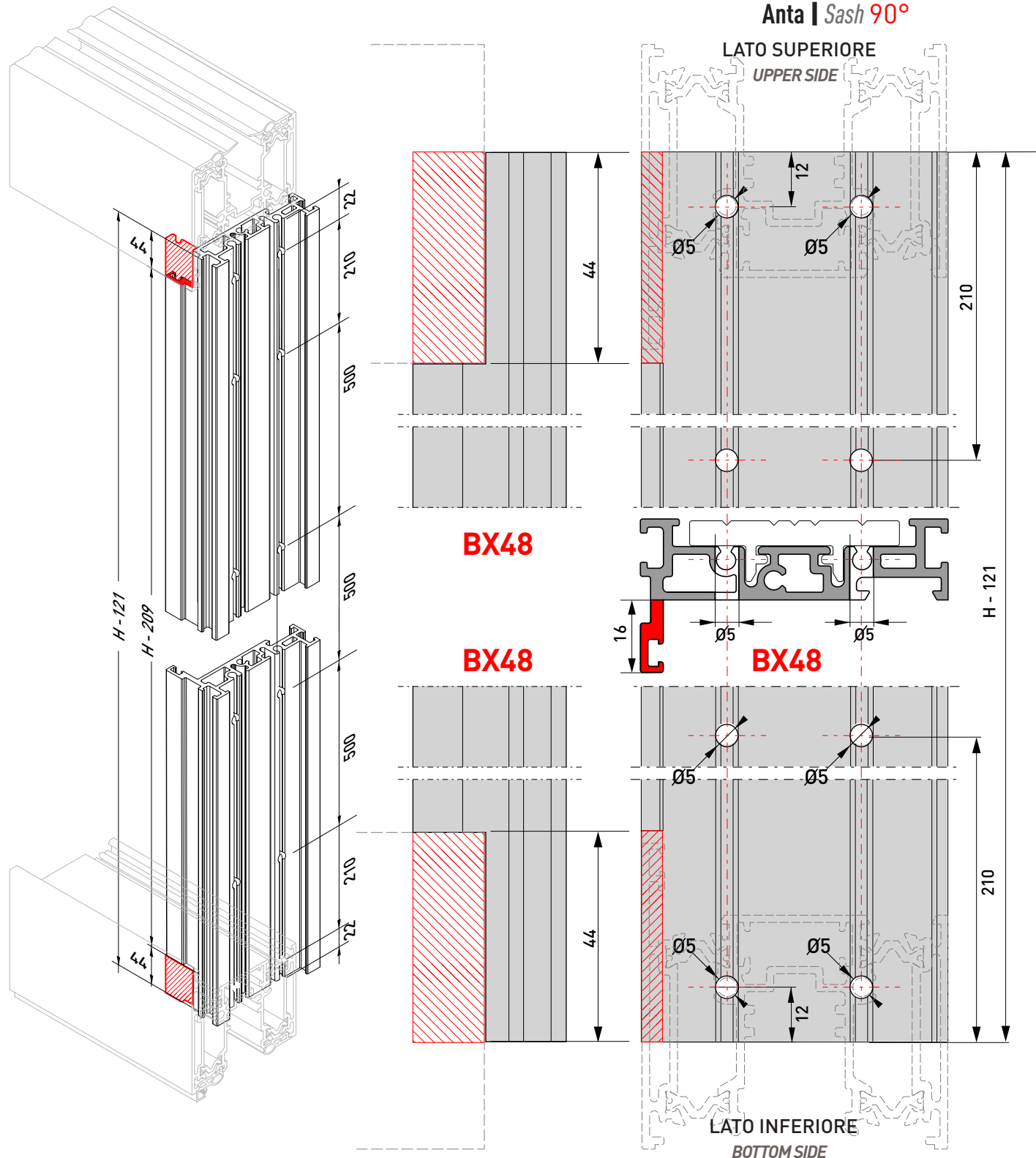

ANTA

SASH

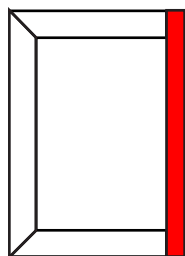

[KIT AHM 16.6745.68]

- Lavorazione Rinforzo Montante Centrale HM16.308
- Tooling for Central Mullion Reinforcement HM16.308

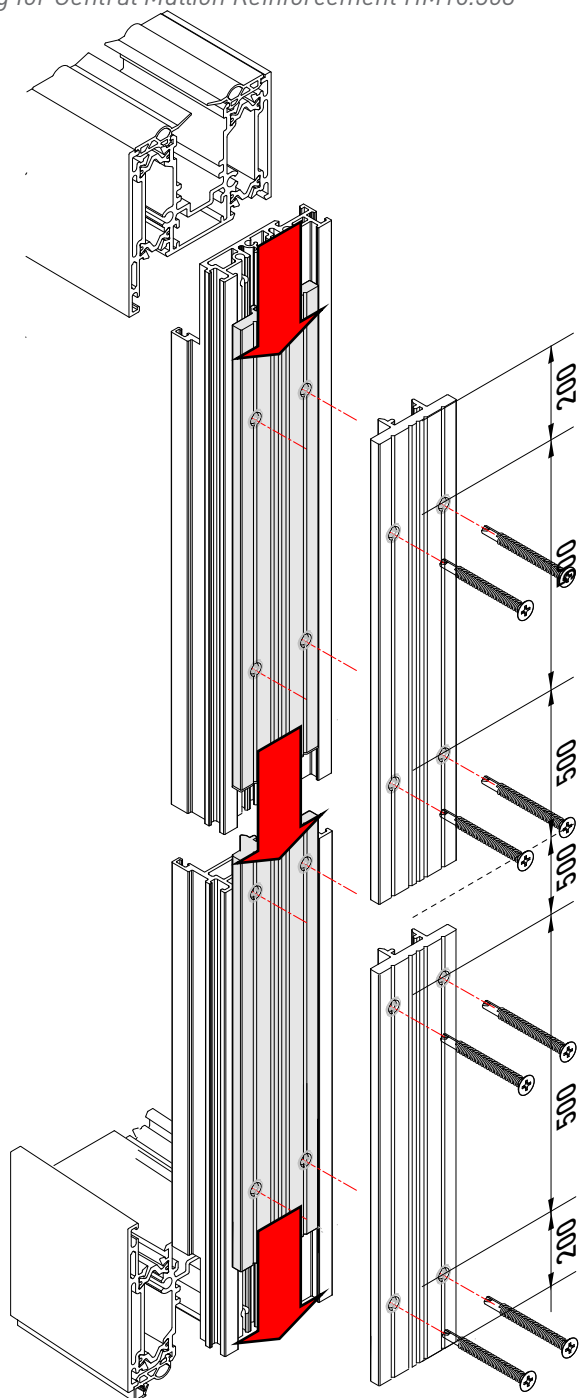

Assemblaggio ad Infilare di HM16.308
Insert HM16.306

Mobile + Mobile
Sliding + Sliding



Mobile + Vetrata
Sliding + Glaze

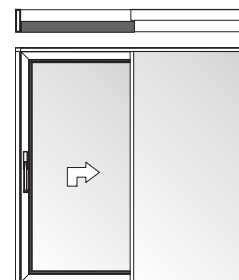

Anta | Sash 90°

LATO SUPERIORE
UPPER SIDE

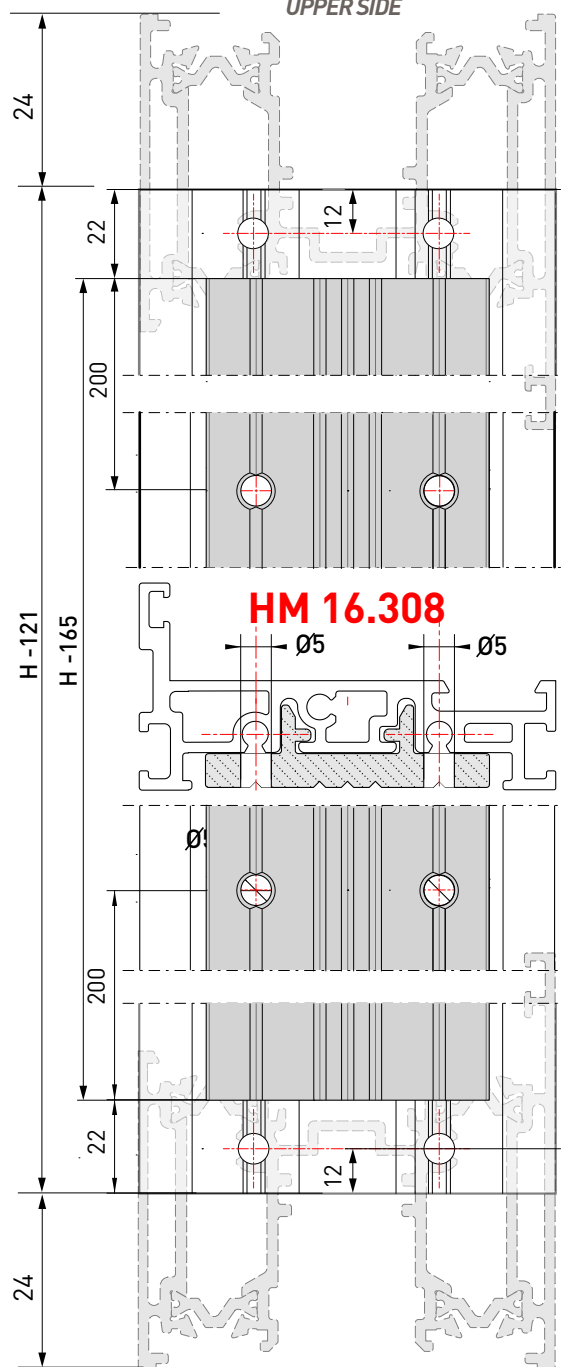

LATO INFERIORE
BOTTOM SIDE

ANTA

SASH

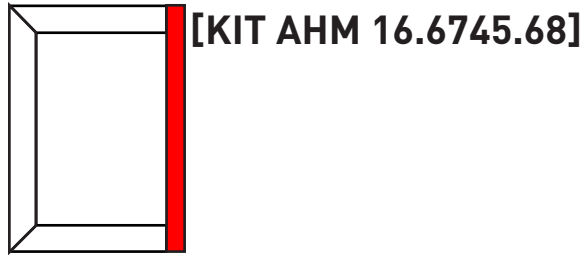

[KIT AHM 16.6745.68]

- Lavorazione e Assemblaggio BX50
- Tooling an Assembling BX50

Mobile + Mobile
Sliding + Sliding

Mobile + Vetrata
Sliding + Glaze

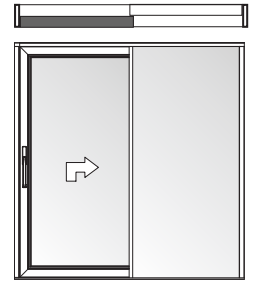
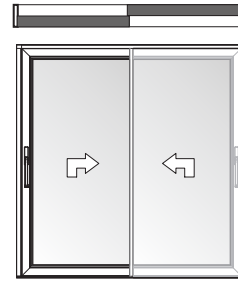

Anta | Sash 90°

LATO SUPERIORE
UPPER SIDE

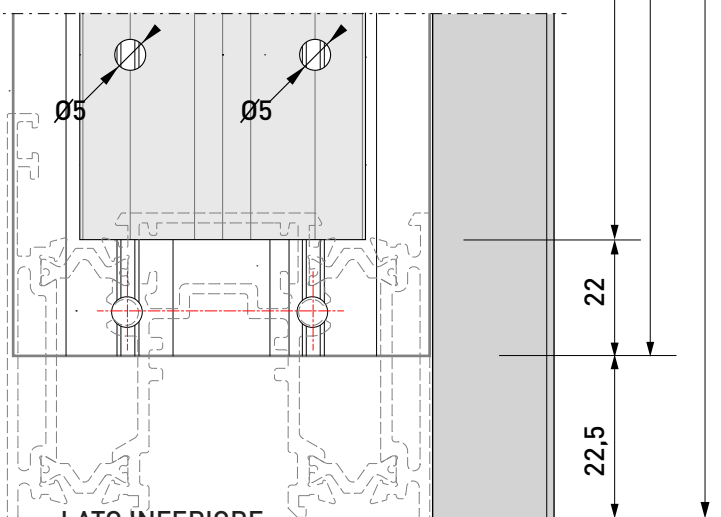
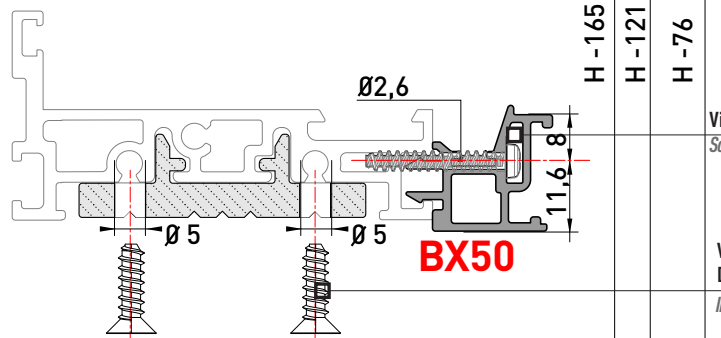
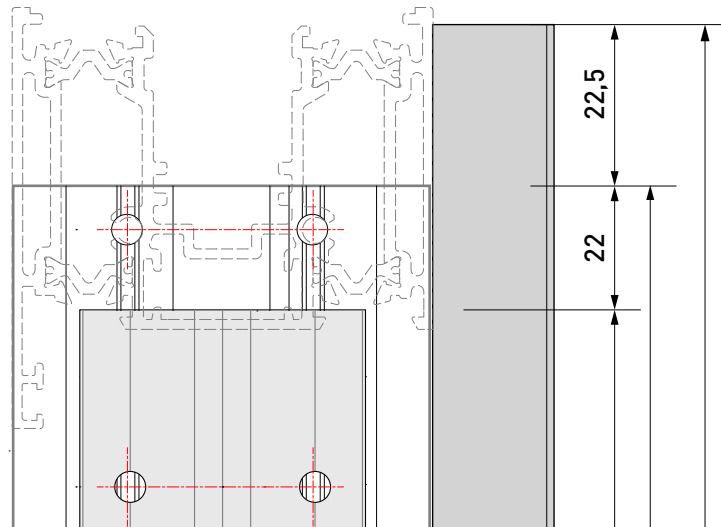

LATO INFERIORE
BOTTOM SIDE

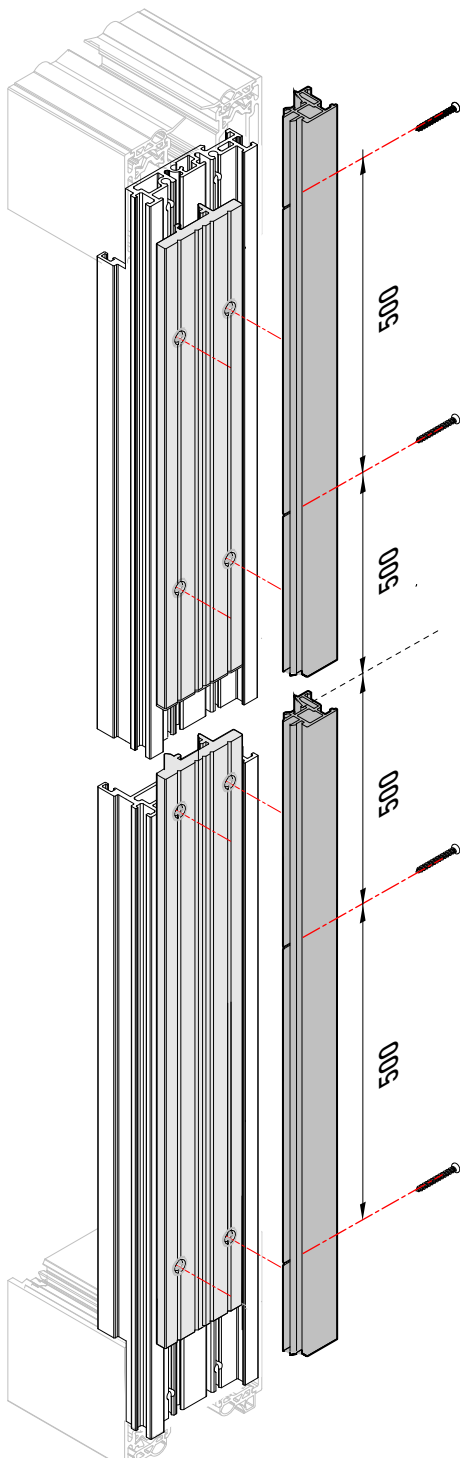

ANTA

SASH

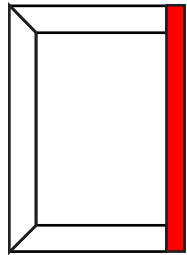

[KIT AHM 16.6745.68]

- Lavorazione Rinforzo Montante Centrale HM16.306
- Tooling for Central Mullion Reinforcement HM16.306

Mobile + Mobile
Sliding + Sliding

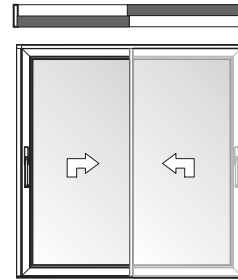

Mobile + Vetrata
Sliding + Glaze

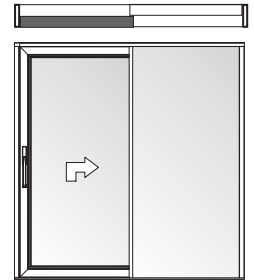

Anta | Sash 90°

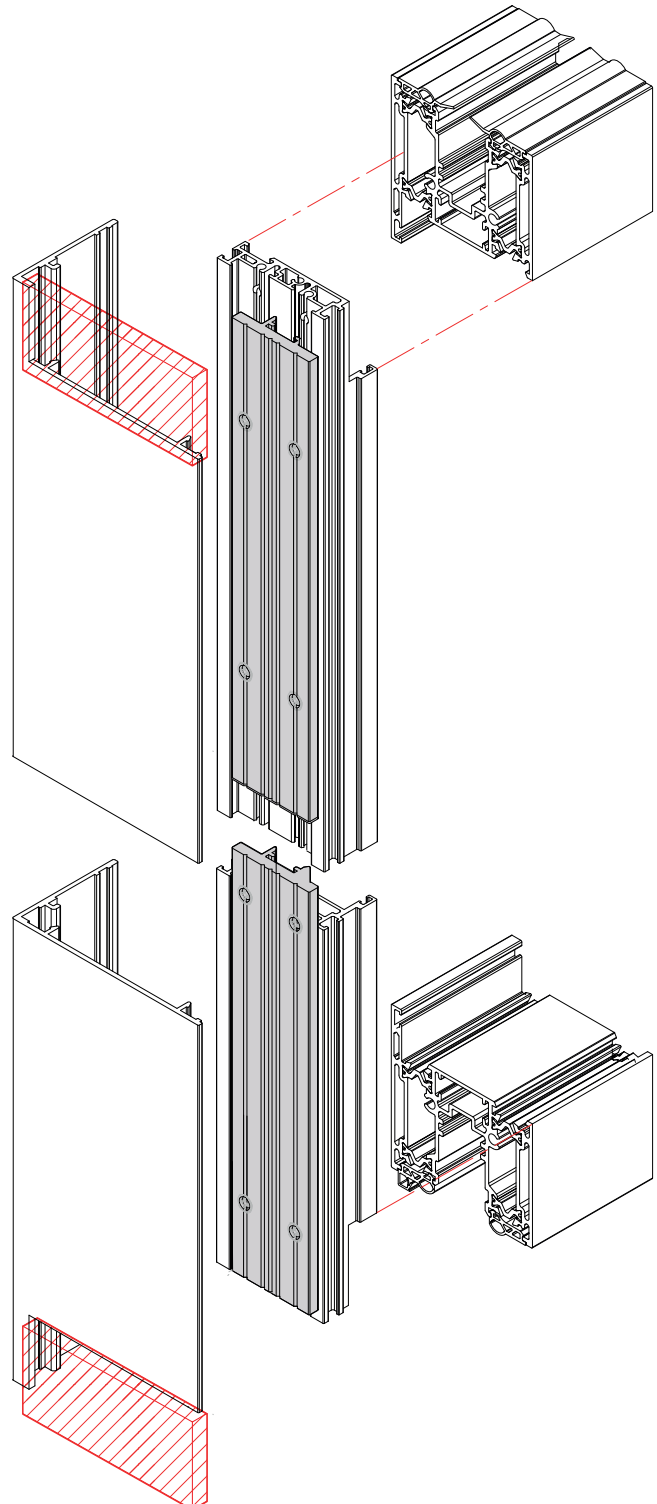
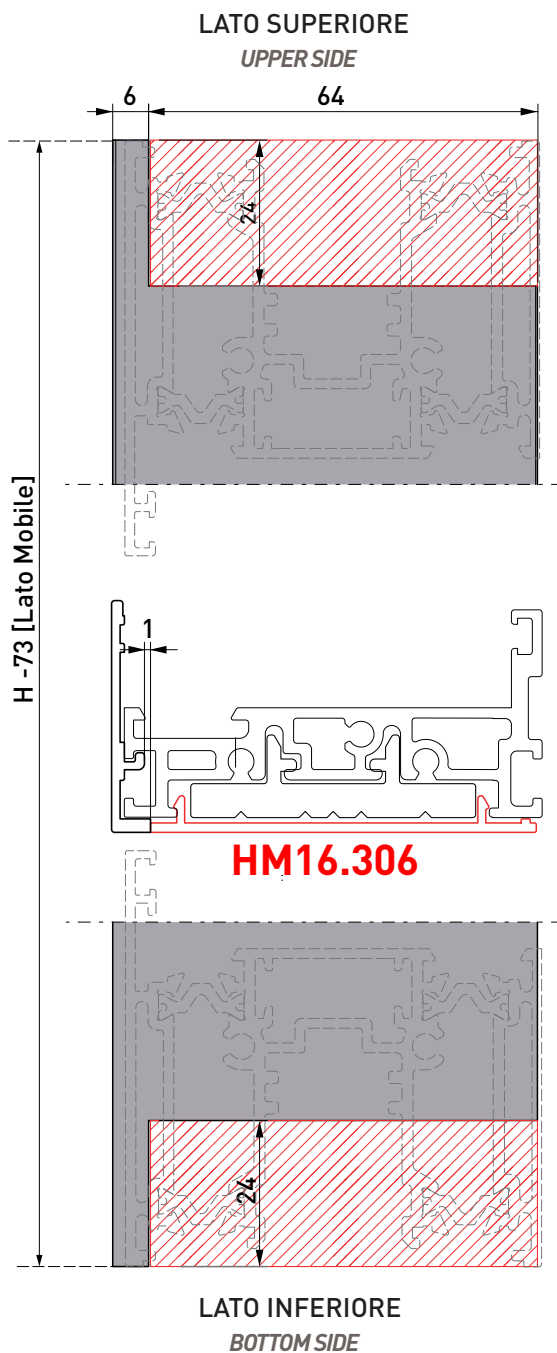

ANTA

SASH

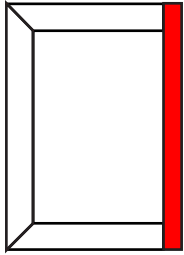

Mobile + Mobile
Sliding + Sliding

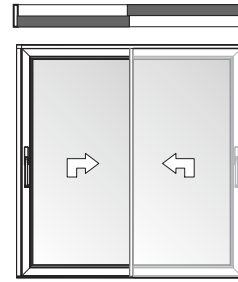

Mobile + Vetrata
Sliding + Glaze

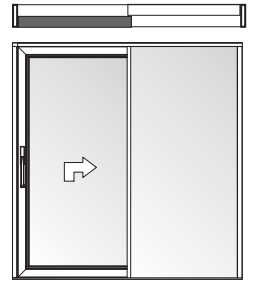

- Assemblaggio Montante Incontro Centrale
- *Assembling for Central Mullion*

Anta | Sash 90°

[KIT AHM 16.6745.68]

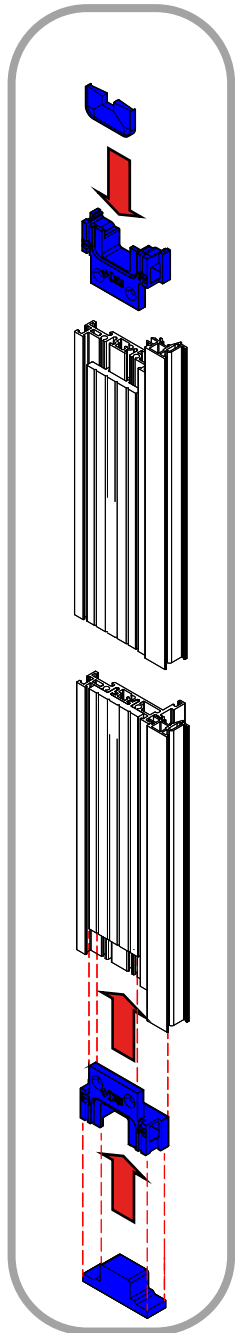

1 Tappo e Spugna Inferiore
Bottom Cap and Sponge

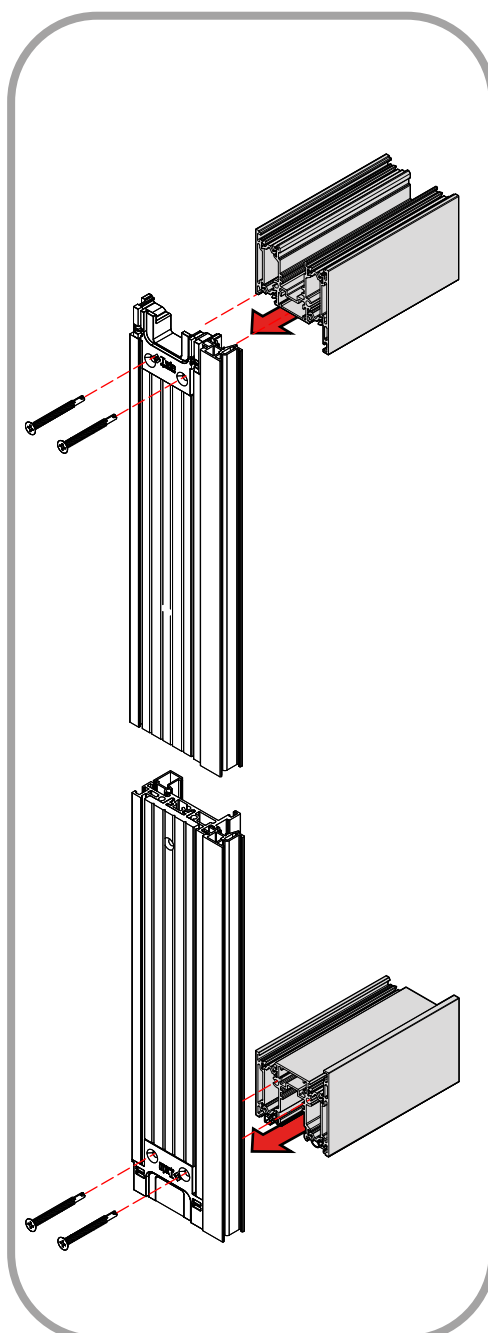

2 Installazione Traversi Sup. e Inf.
Upper and Bottom Transoms Assembling

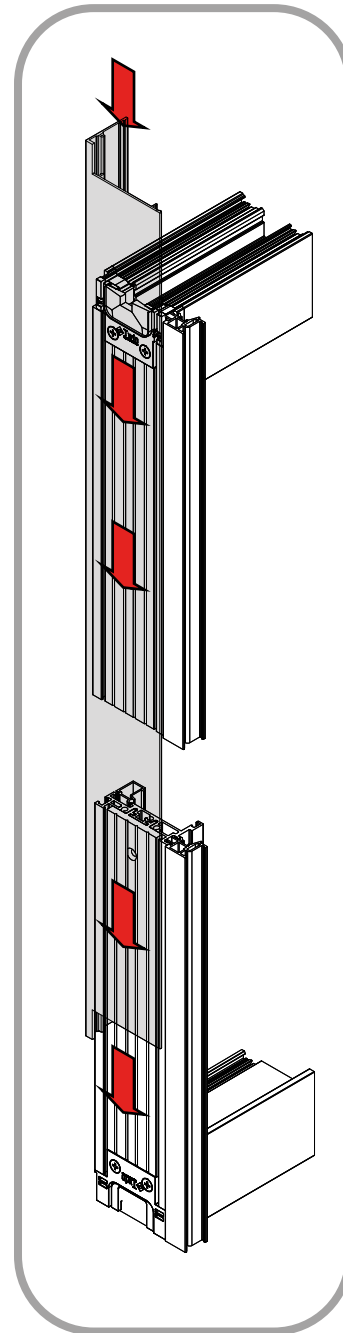

3 Inserimento del Carter HM16.308
Carter HM16.308 Inserting

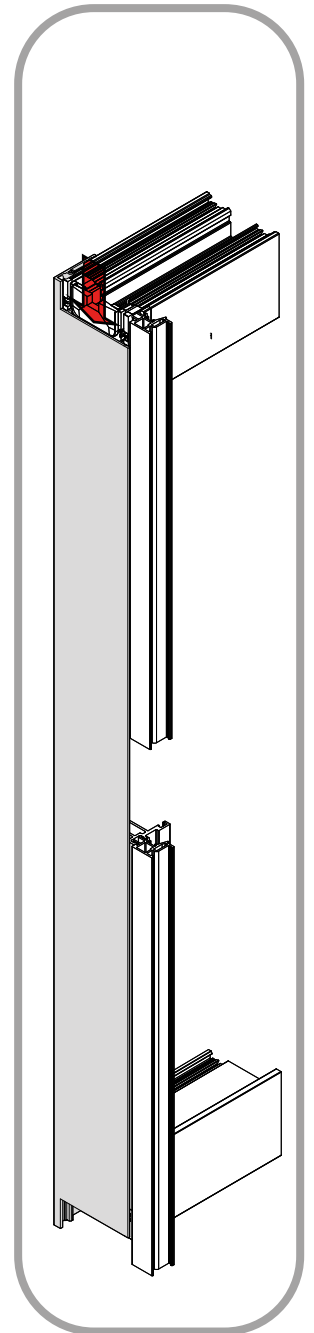

4 Tappo e Spazzolino Superiore
Upper Cap and Brush

ANTA

SASH

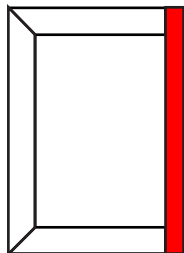

- Lavorazione CARTER Montante Centrale HM16.306
- Tooling for Central Mullion CARTER HM16.306

Mobile + Mobile
Sliding + Sliding



Mobile + Vetrata
Sliding + Glaze

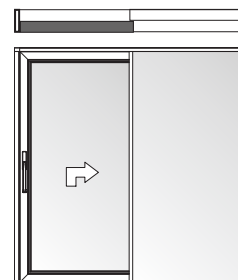

Anta | Sash 90°

[KIT AHM 16.6745.68]

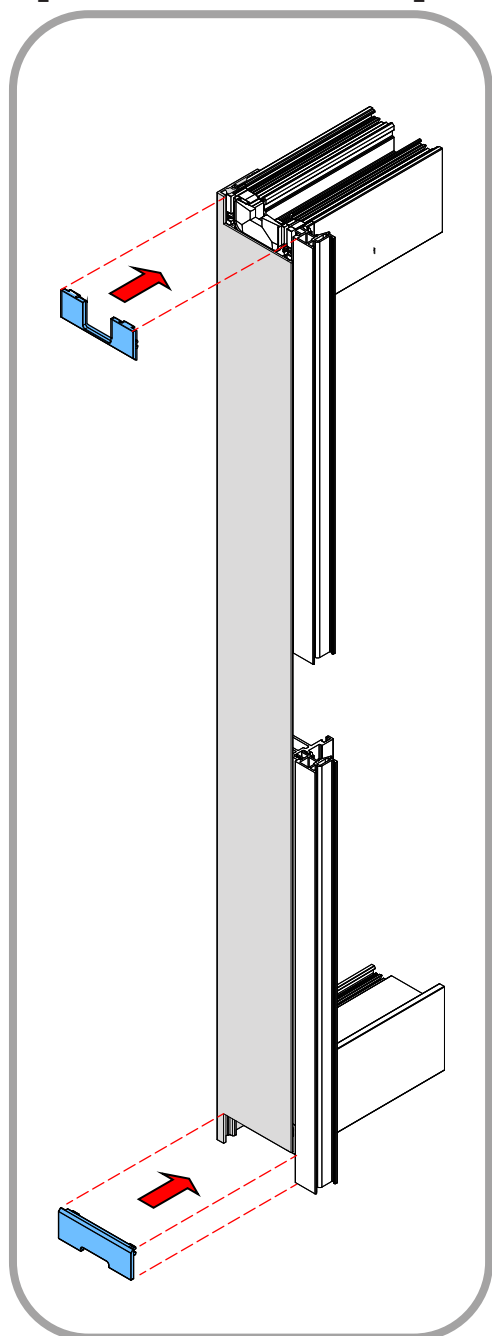

5 Applicazione Tappi Coprilavorazione Superiore e Inferiore
Upper and Bottom Finishing Caps Installation

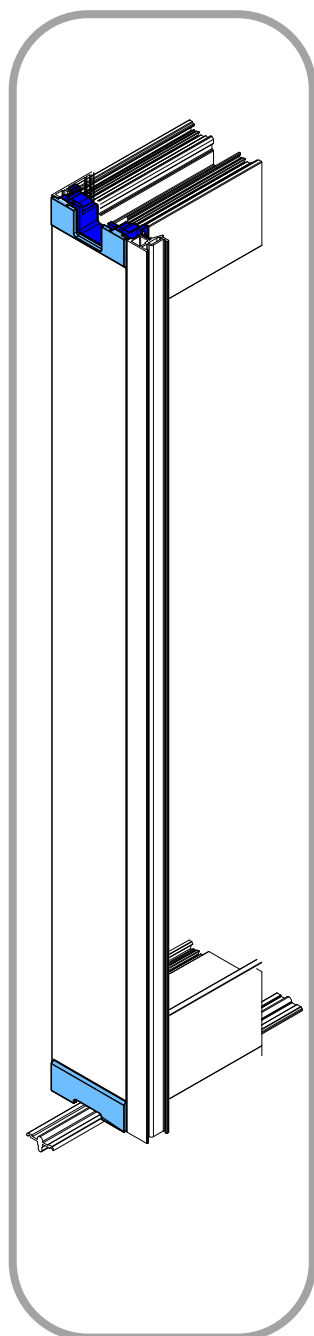

6 Sequenza Completata
Sequence Completed

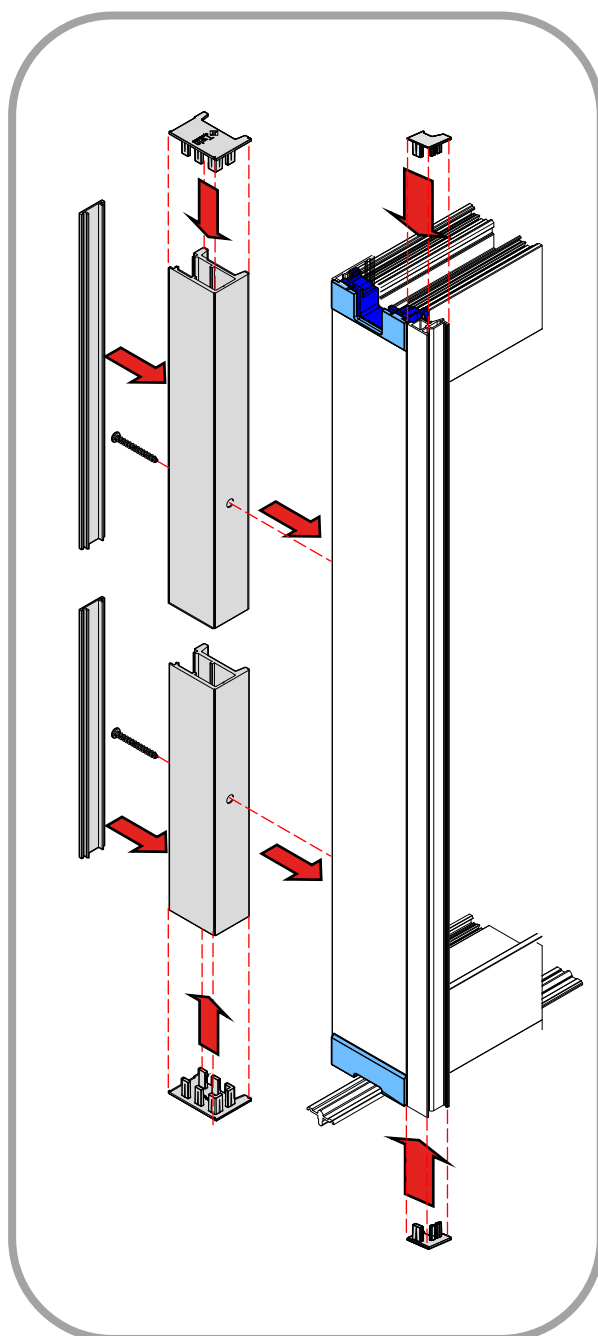

7 Installazione Tappi di Finitura +
Maniglione Trascinavetro con Viti e Cover di Finitura [OPZIONALE]
Installing Finishing Caps +
Sash Mover Handle with screws and finishing Cover [OPTIONAL]



ANTA

SASH

- ESPLOSO ASSONOMETRICO
- AXONOMETRIC EXPLODED VIEW

Mobile + Mobile
Sliding + Sliding

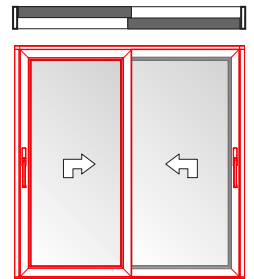

Anta | Sash 45°

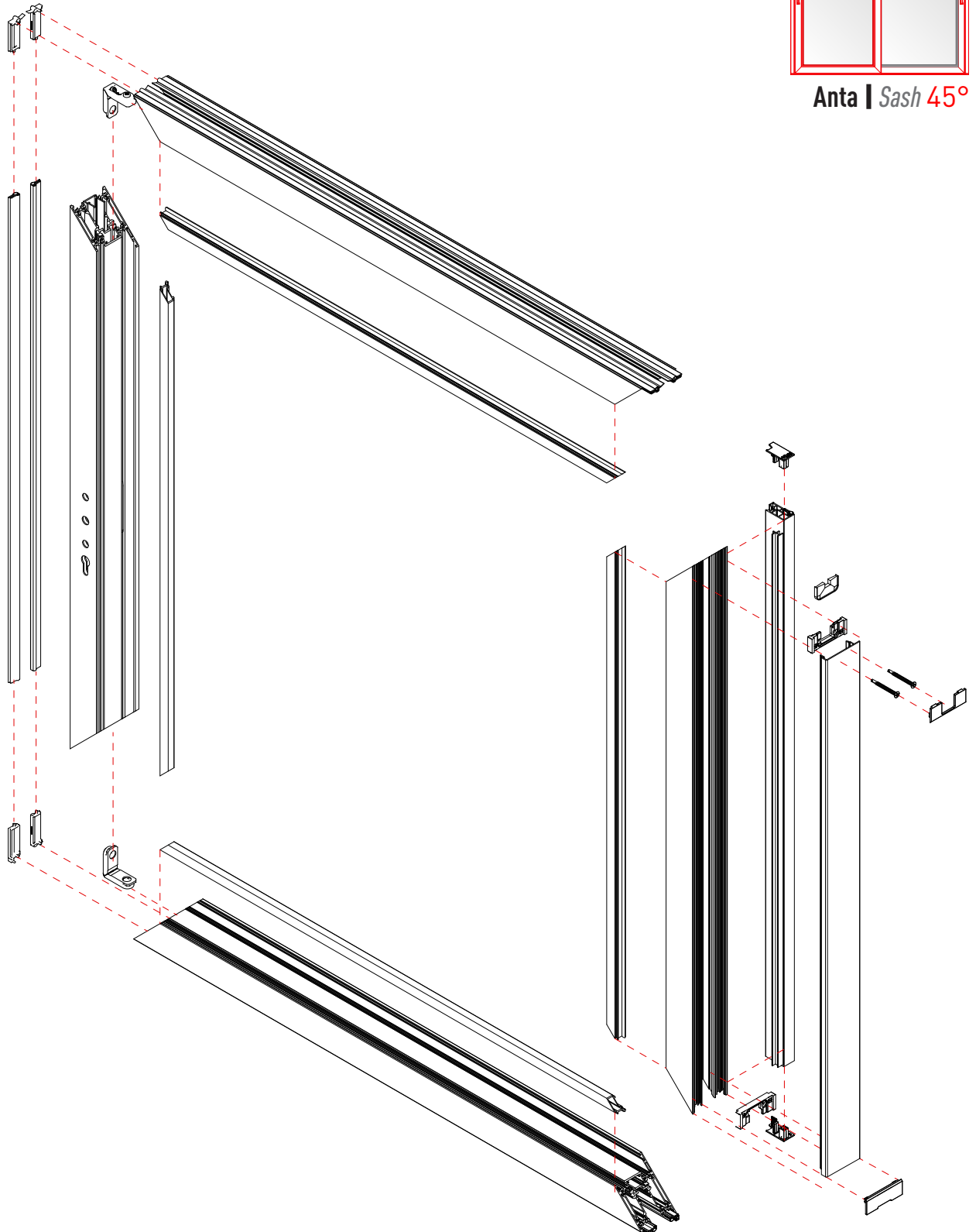



ANTA

SASH

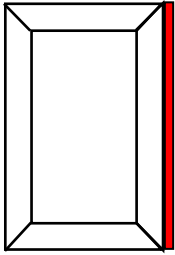

- Lavorazioni Incontro Centrale BX51
- Tooling for Central Profile BX51

Mobile + Mobile
Sliding + Sliding

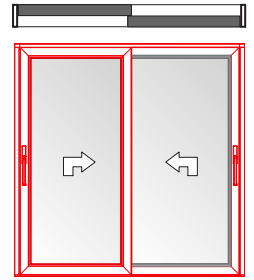

Anta | Sash 45°

LATO SUPERIORE
UPPER SIDE

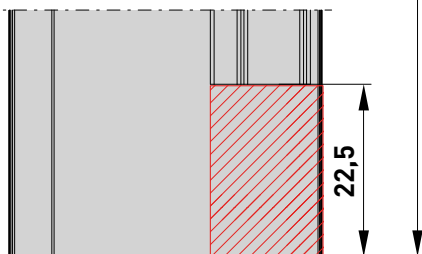
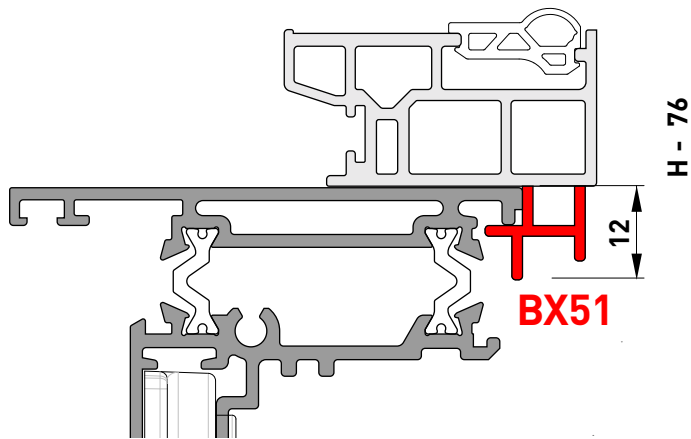
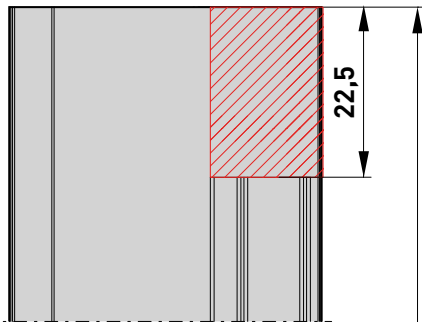

LATO INFERIORE
BOTTOM SIDE

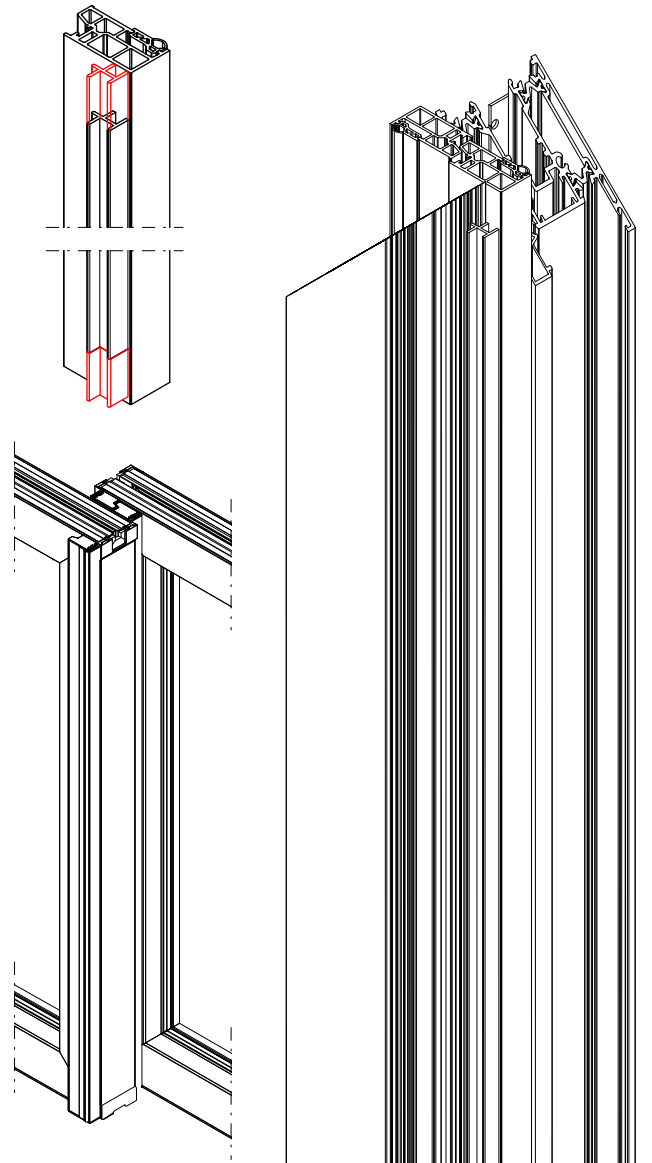

ANTA

SASH

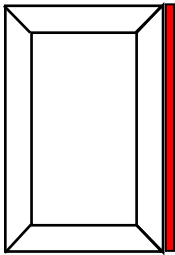

- Lavorazione Rinforzo Montante Centrale HM16.307
- Tooling for Central Mullion Reinforcement HM16.307

Mobile + Mobile
Sliding + Sliding

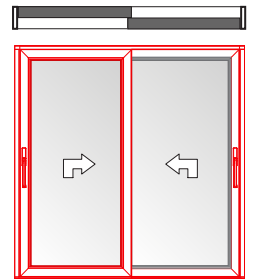

Anta | Sash 45°

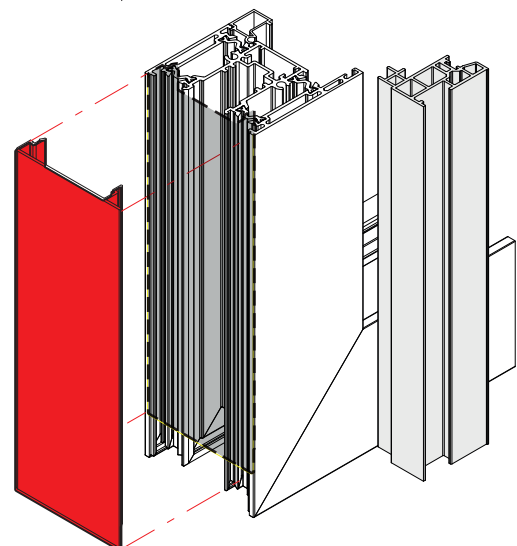
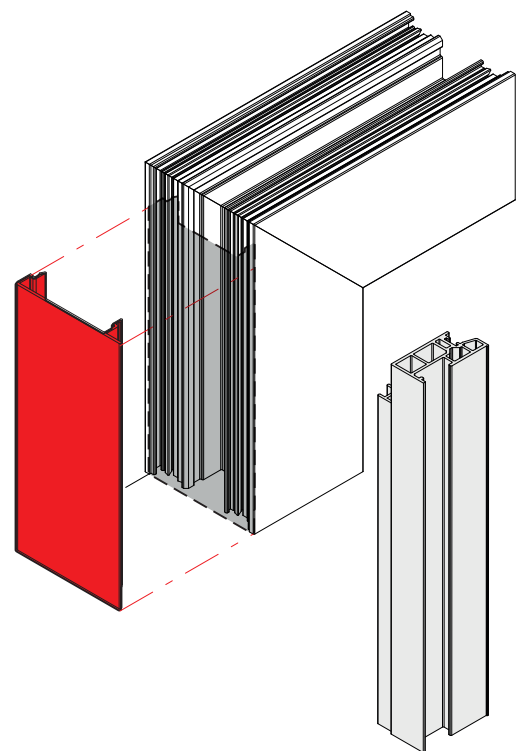
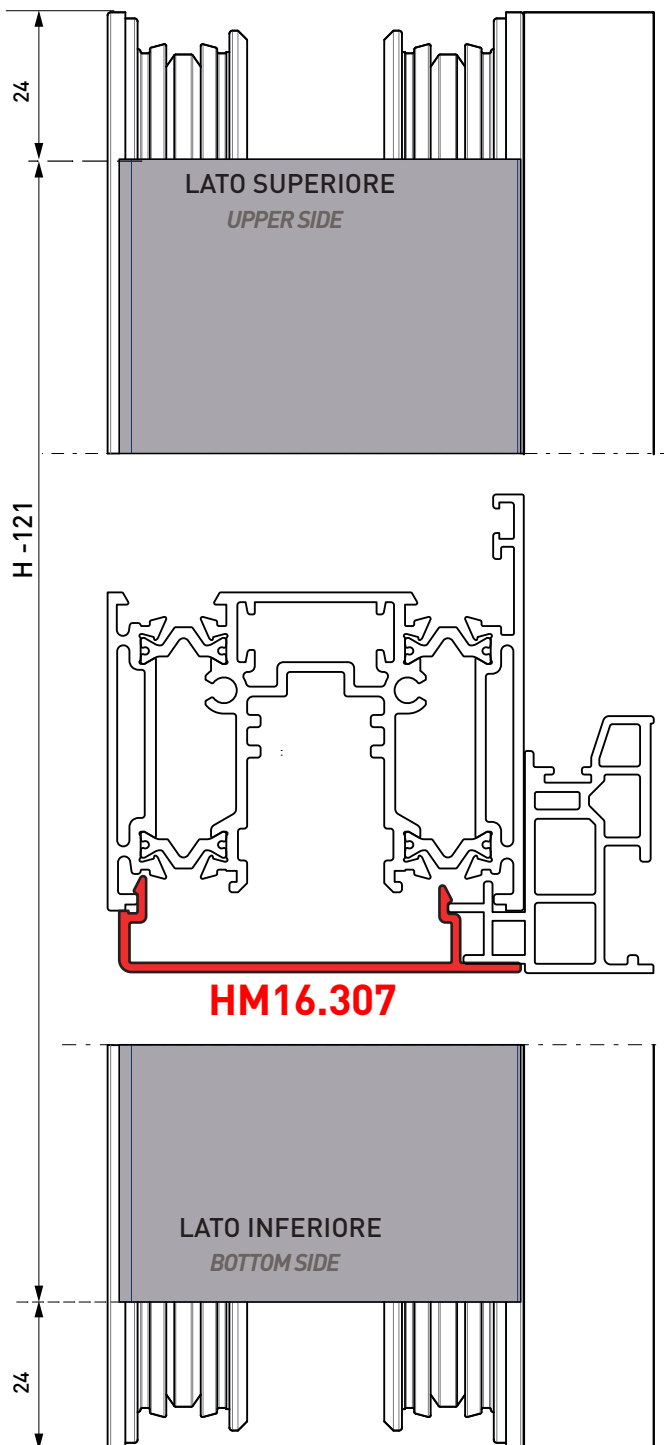



ANTA

SASH

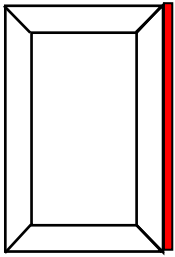

- Assemblaggio Carter Incontro Centrale
- Assembling Central Profile Carter

Mobile + Mobile
Sliding + Sliding

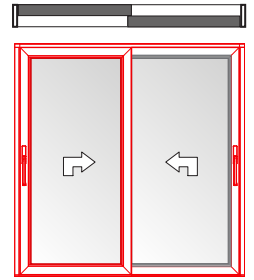

Anta | Sash 45°

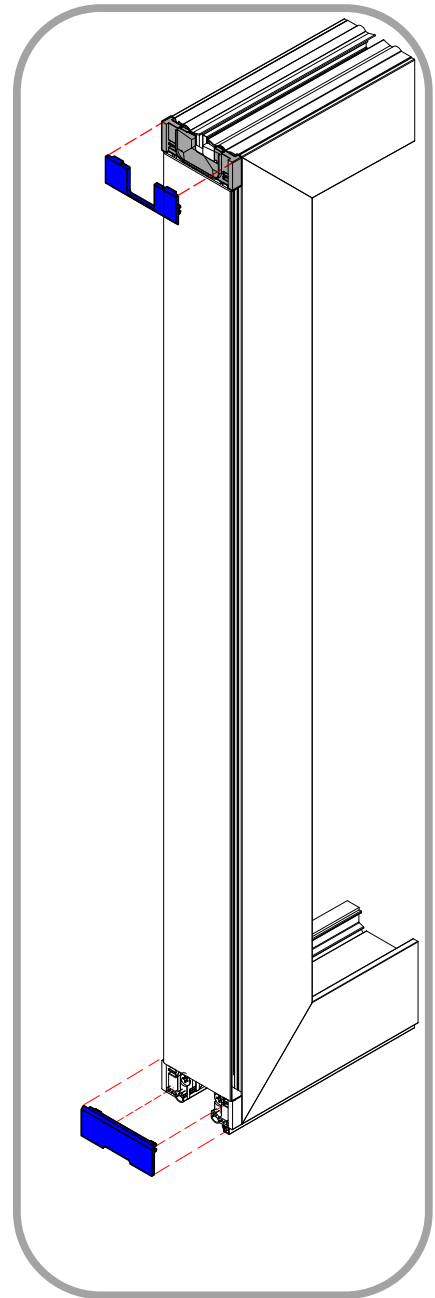
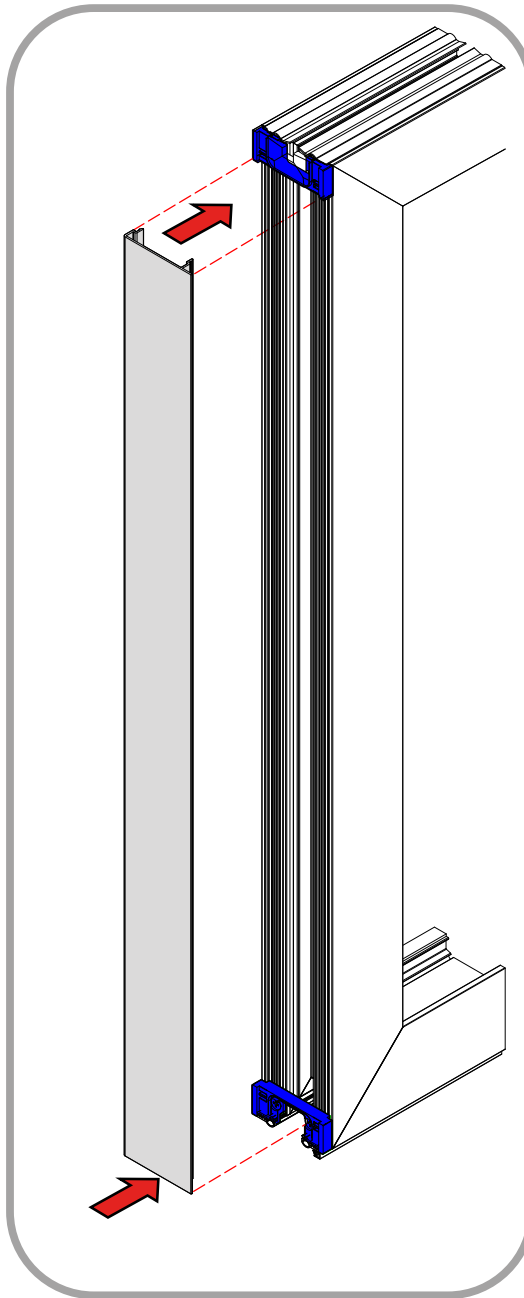
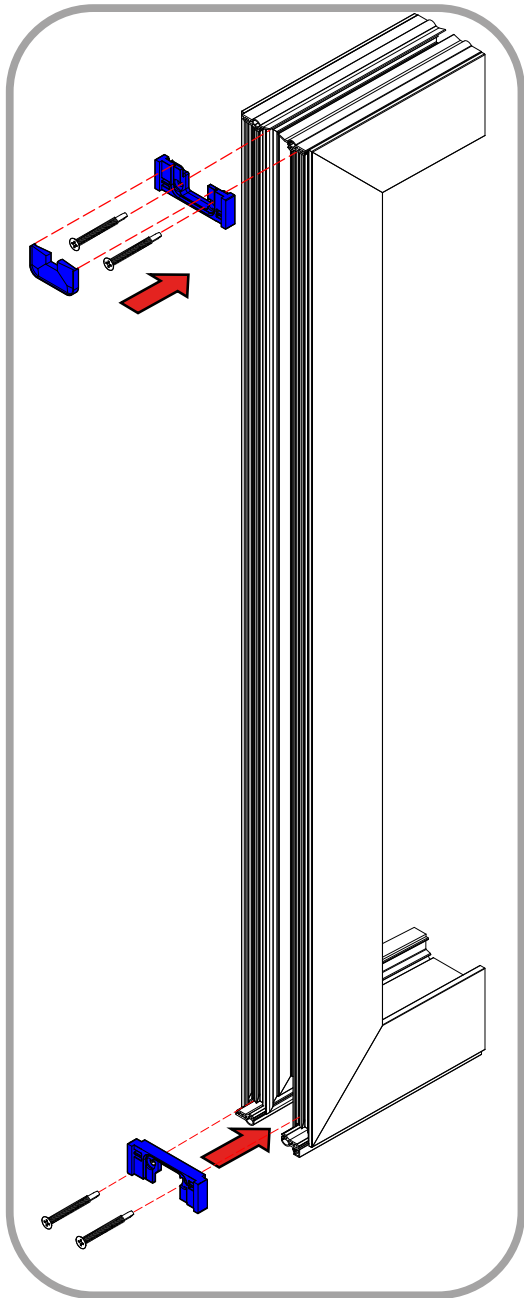

1 Applicazione Tappo e Spazzolino Superiore e Inferiore
Upper Cap with Brush and Bottom Cap Installation
Installation

2 Installazione Carter HX16.307
Carter Profile HX16.307 Installation

3 Tappo Superiore Coprilavorazione per Fissaggio Spazzolino e Tappo inferiore Coprilavorazione
Upper Finishing Cap to fix Upper Brush and Bottom Finishing Cap



ANTA

SASH

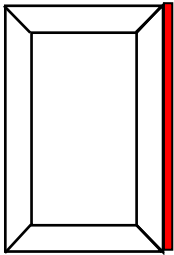

- Assemblaggio Carter Incontro Centrale
- Assembling Central Profile Carter

Mobile + Mobile
Sliding + Sliding

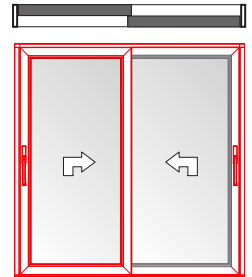

Anta | Sash 45°

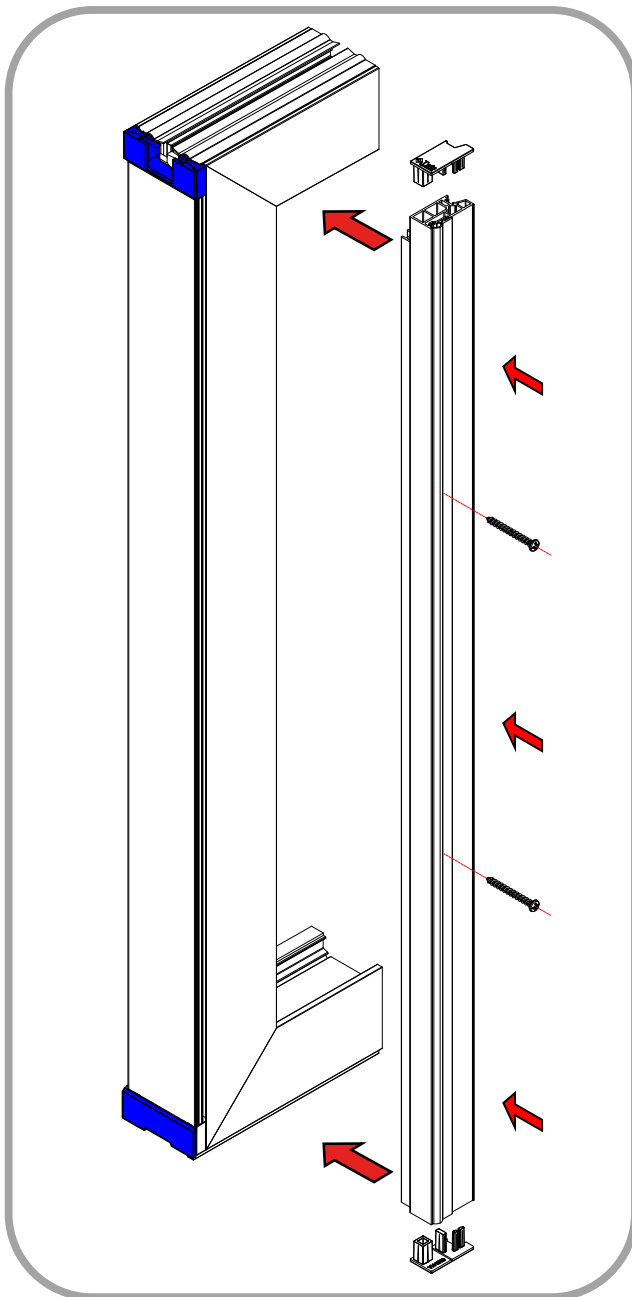

4 Maniglione Trascinavetro con Viti e Cover di Finitura [OPZIONALE]
Sash Mover Handle with screws and finishing Cover [OPTIONAL]

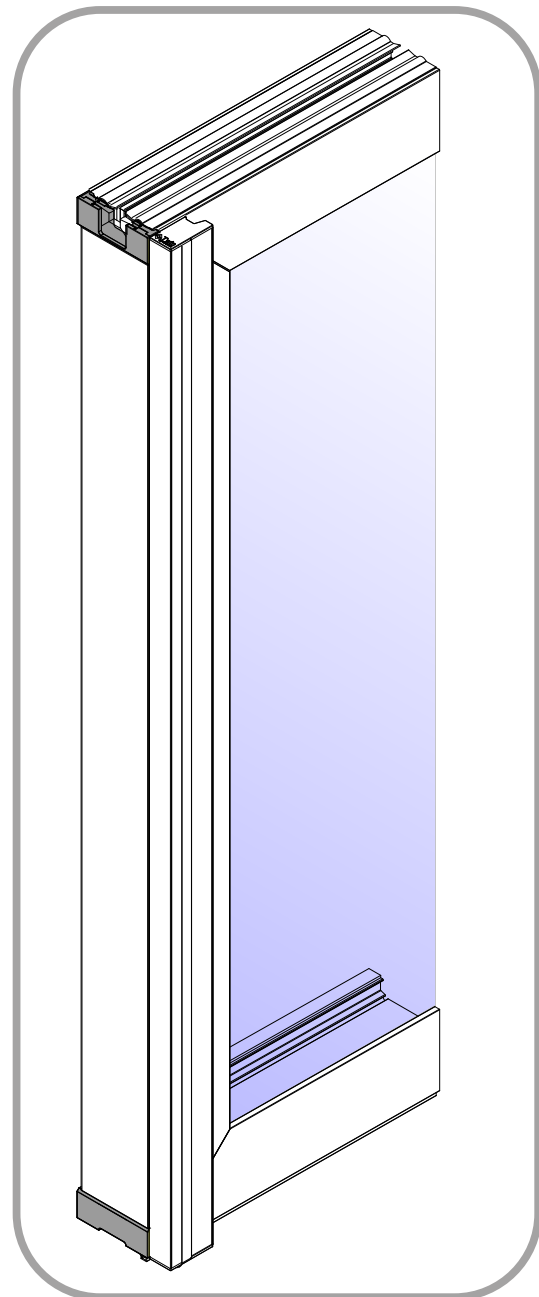

5 Sequenza Completa
Complete Sequence

ANTA

SASH

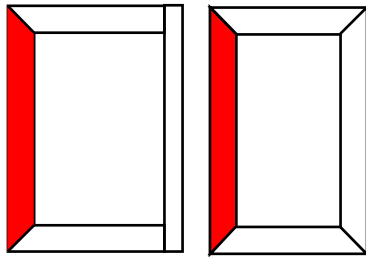

- Lavorazioni ASTA
- Tooling Handle ROD

2 Scorrevoli
2 Sliding

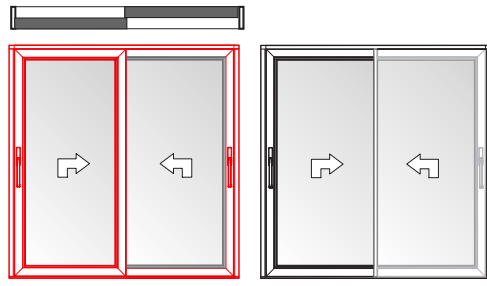

Anta | Sash 45°

Anta | Sash 90°

1 Scorrevole
Sliding

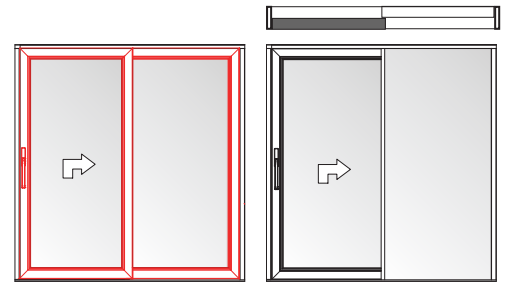

Anta | Sash 45°

Anta | Sash 90°

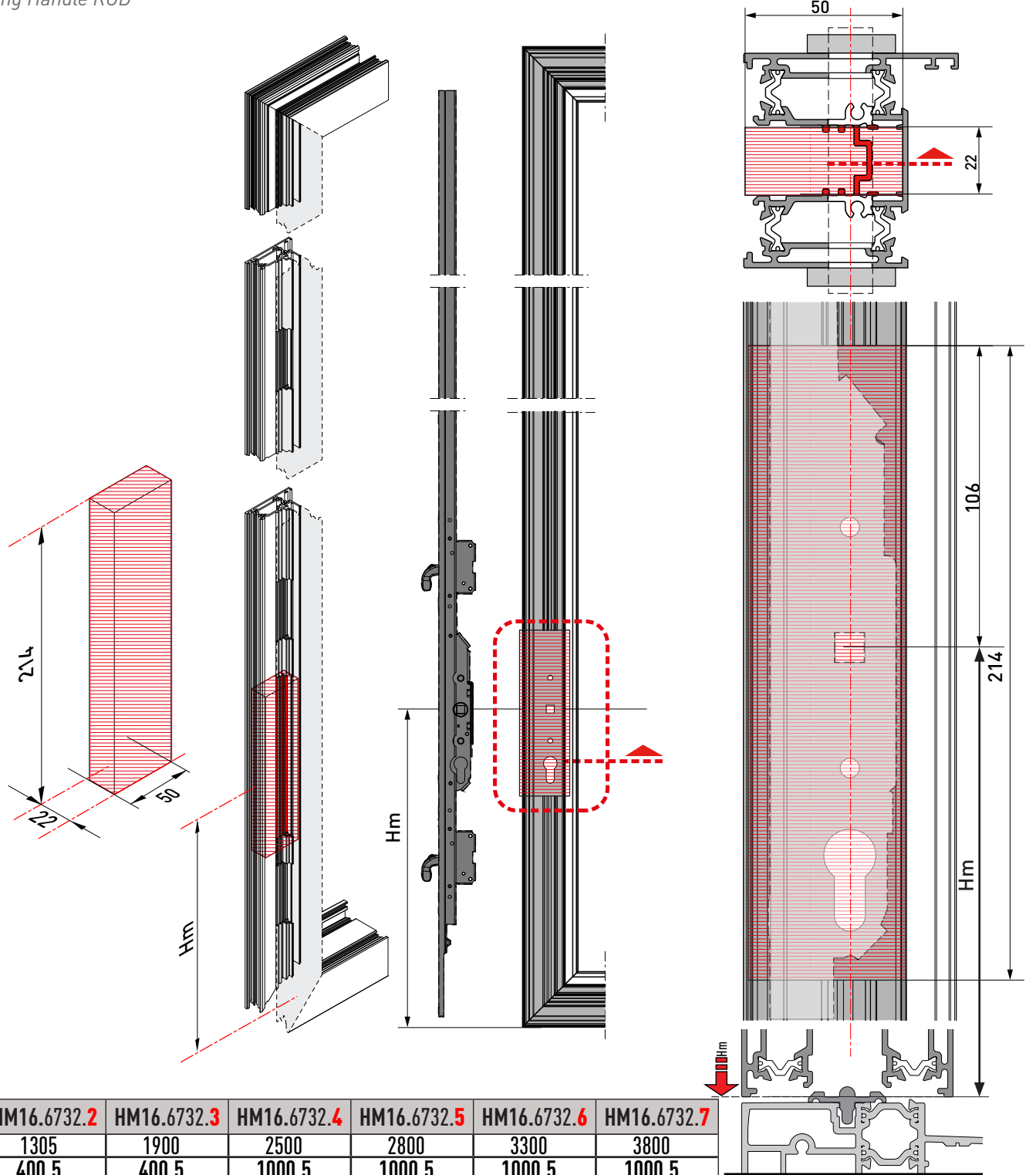

	HM16.6732.2	HM16.6732.3	HM16.6732.4	HM16.6732.5	HM16.6732.6	HM16.6732.7
L Asta	1305	1900	2500	2800	3300	3800
Hm	400.5	400.5	1000.5	1000.5	1000.5	1000.5

ANTA
SASH

2 Scorrevoli
2 Sliding

1 Scorrevole
Sliding

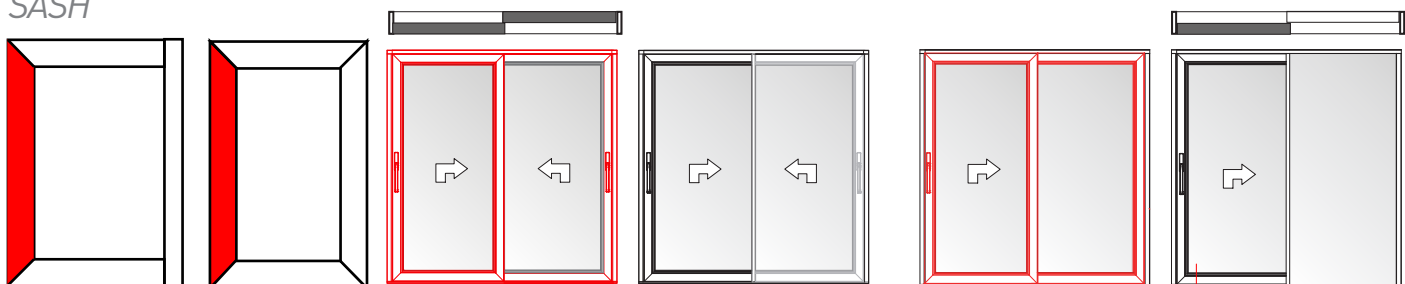

- Lavorazioni ASTA
- Tooling Handle ROD

Anta | Sash 45°

Anta | Sash 90°

Anta | Sash 45°

Anta | Sash 90°

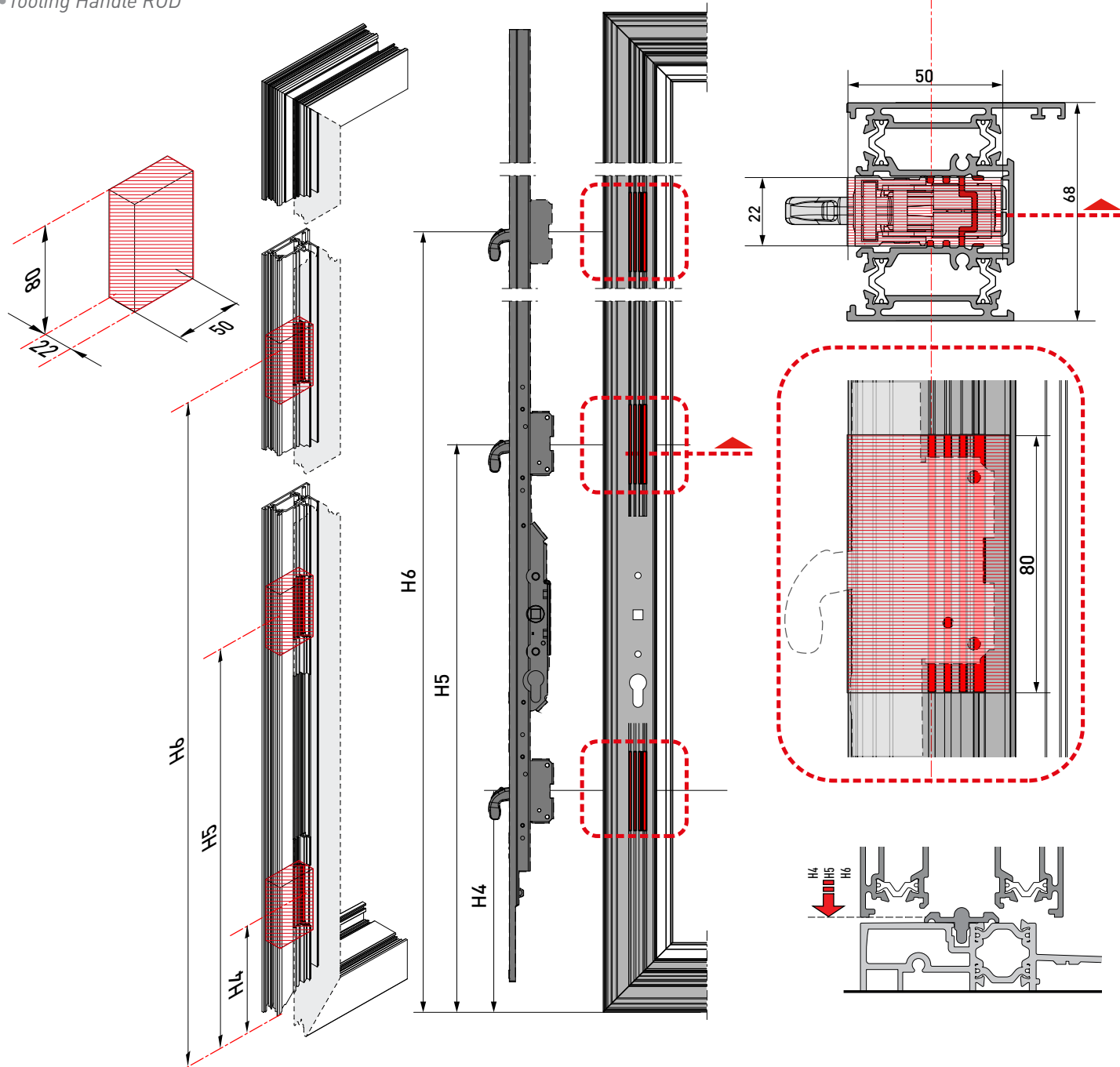

	HM16.6732.2	HM16.6732.3	HM16.6732.4	HM16.6732.5	HM16.6732.6	HM16.6732.7
L Asta	1305	1900	2500	2800	3300	3800
H4	212	212	212	212	212	212
H5	582	1082	1680	1212	1412	1412
H6	-	-	-	2112	2512	2512

ANTA
SASH

2 Scorrevoli
2 Sliding

1 Scorrevole
Sliding

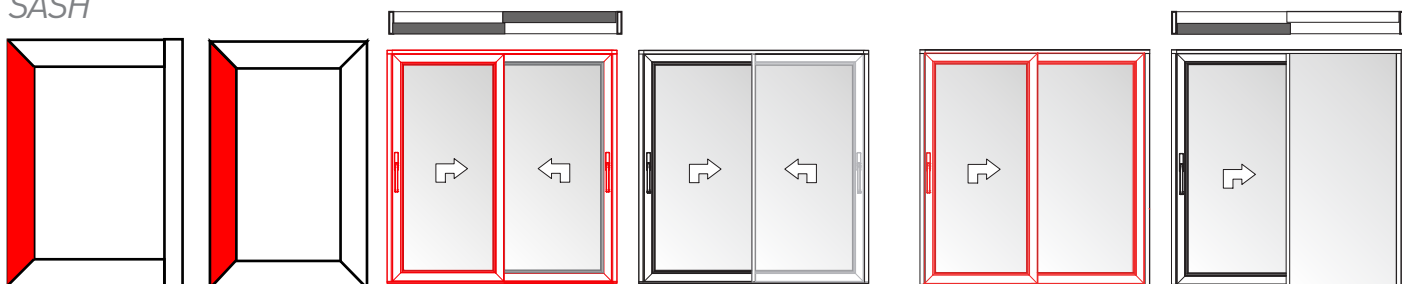

• Installazione
AMMORTIZATORE Serratura

Anta | Sash 45°

Anta | Sash 90°

Anta | Sash 45°

Anta | Sash 90°

• DAMPER LOCK Installation

AHM 10.94

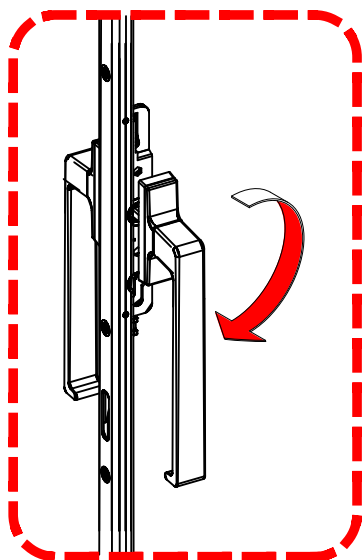

1 POSIZIONE INIZIALE
STARTING POSITION

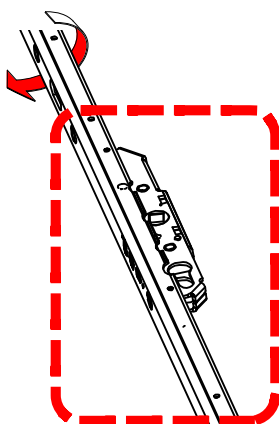

2 PREDISPOSIZIONE ATTACCHI
PREDISPOSITION for CONNECTION

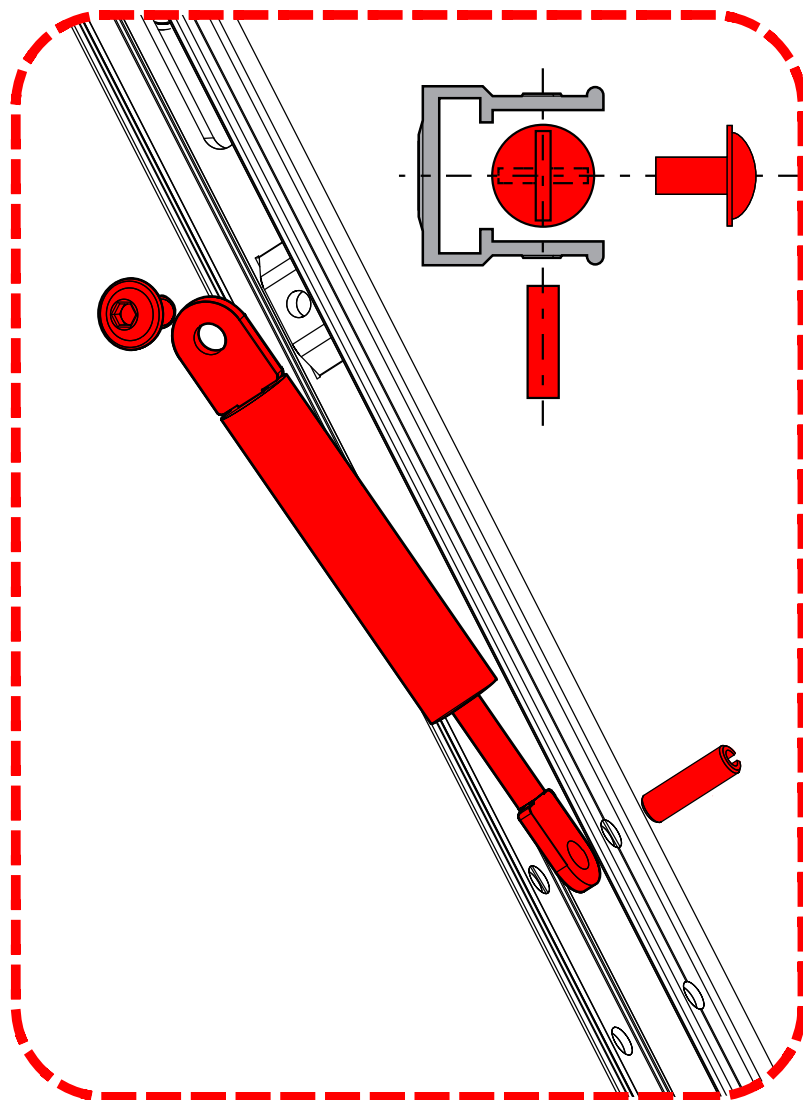

3 INSTALLAZIONE
INSTALLATION



Per ALZANTE SCORREVOLE fino a 400 Kg Portata MAX
For LIFT & SLIDE Up to 400 kg weight MAX

ANTA

SASH

2 Scorrevoli
2 Sliding

1 Scorrevole
Sliding

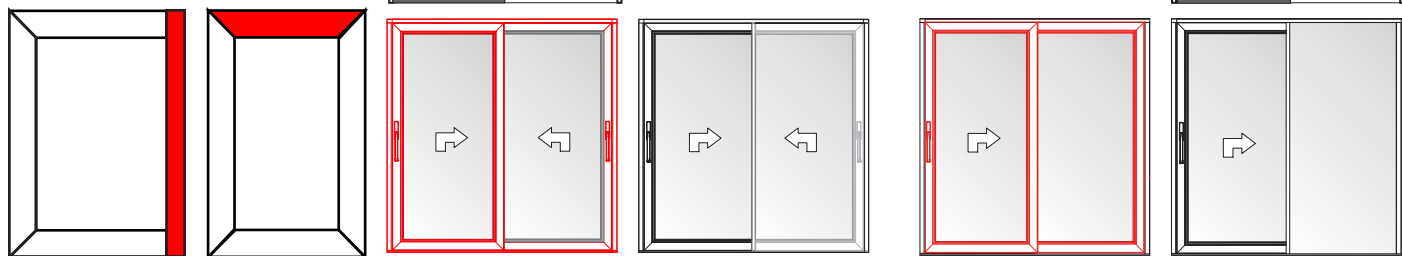

- RALLENTY Lavorazioni su HM16.204

• Tooling on HM16.204 for RALLENTY

Anta | Sash 45°

Anta | Sash 90°

Anta | Sash 45°

Anta | Sash 90°

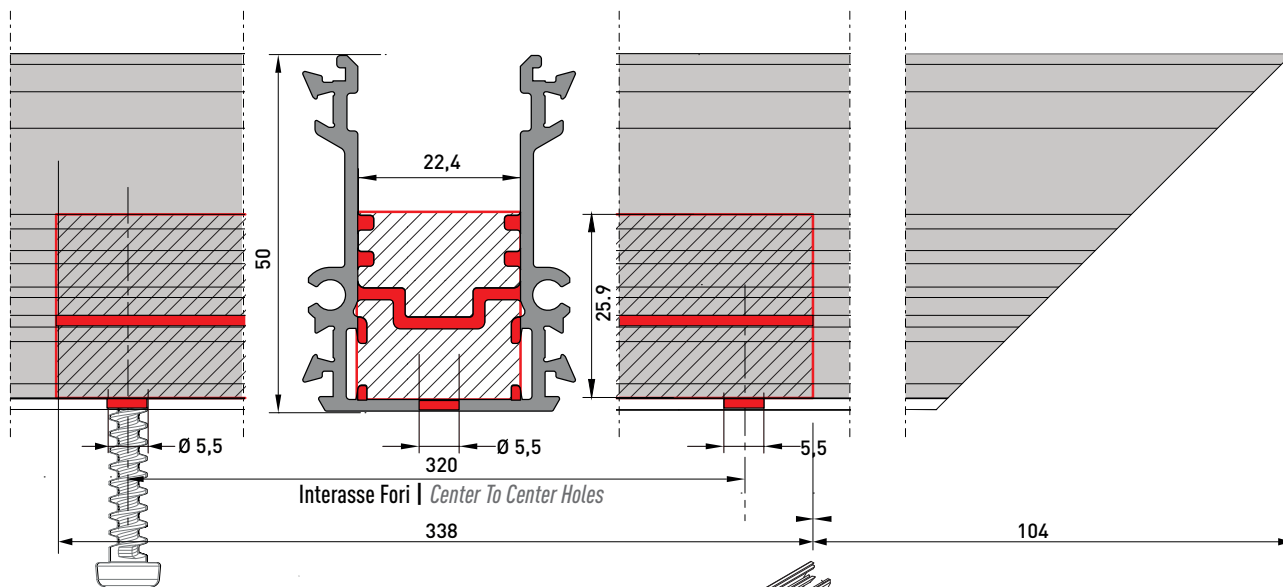
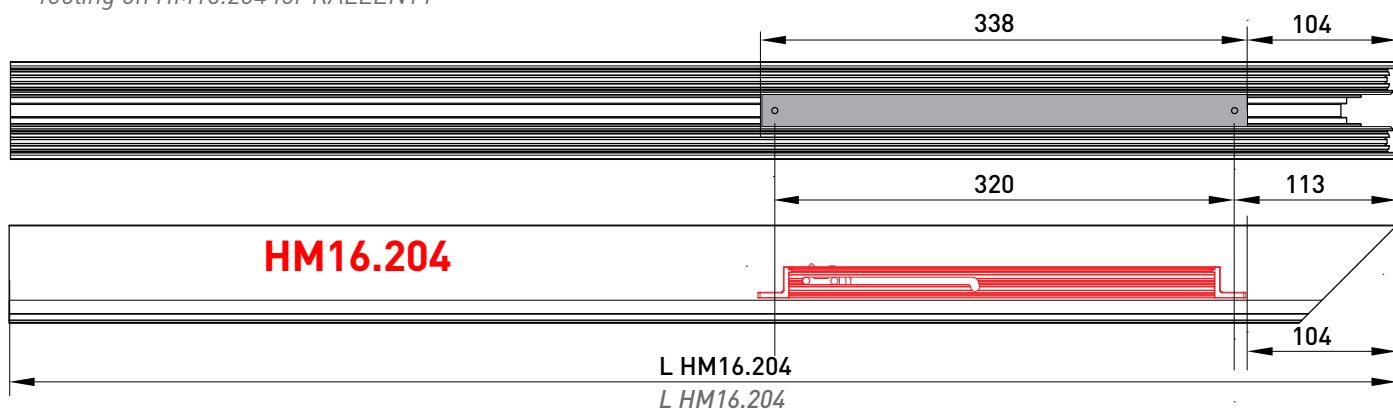

Vite Dim. \varnothing 6 mm. [Fornita nel KIT]
Screw Dim. \varnothing 6 mm. [Provided with KIT]

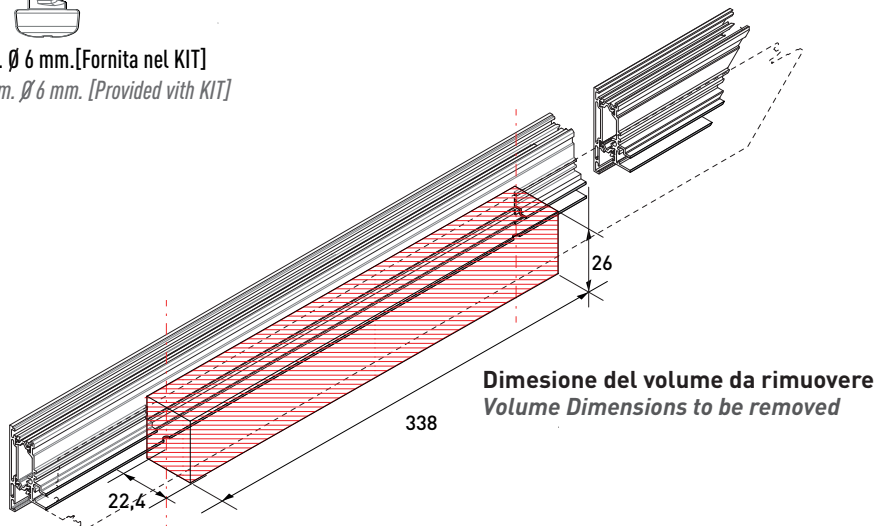

ANTA

SASH

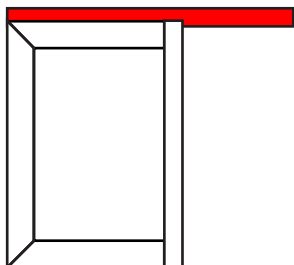

2 Scorrevoli
2 Sliding

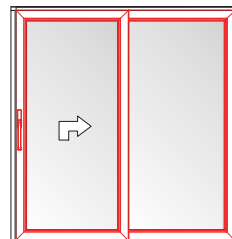
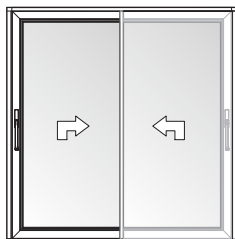
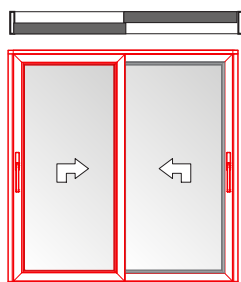

1 Scorrevole
Sliding

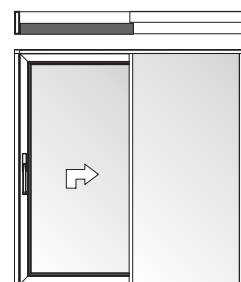

- RALLENTY Lavorazioni su ASX10.26 Anta | Sash 45° Anta | Sash 90° Anta | Sash 45° Anta | Sash 90°

• Tooling on ASX10.26 for RALLENTY

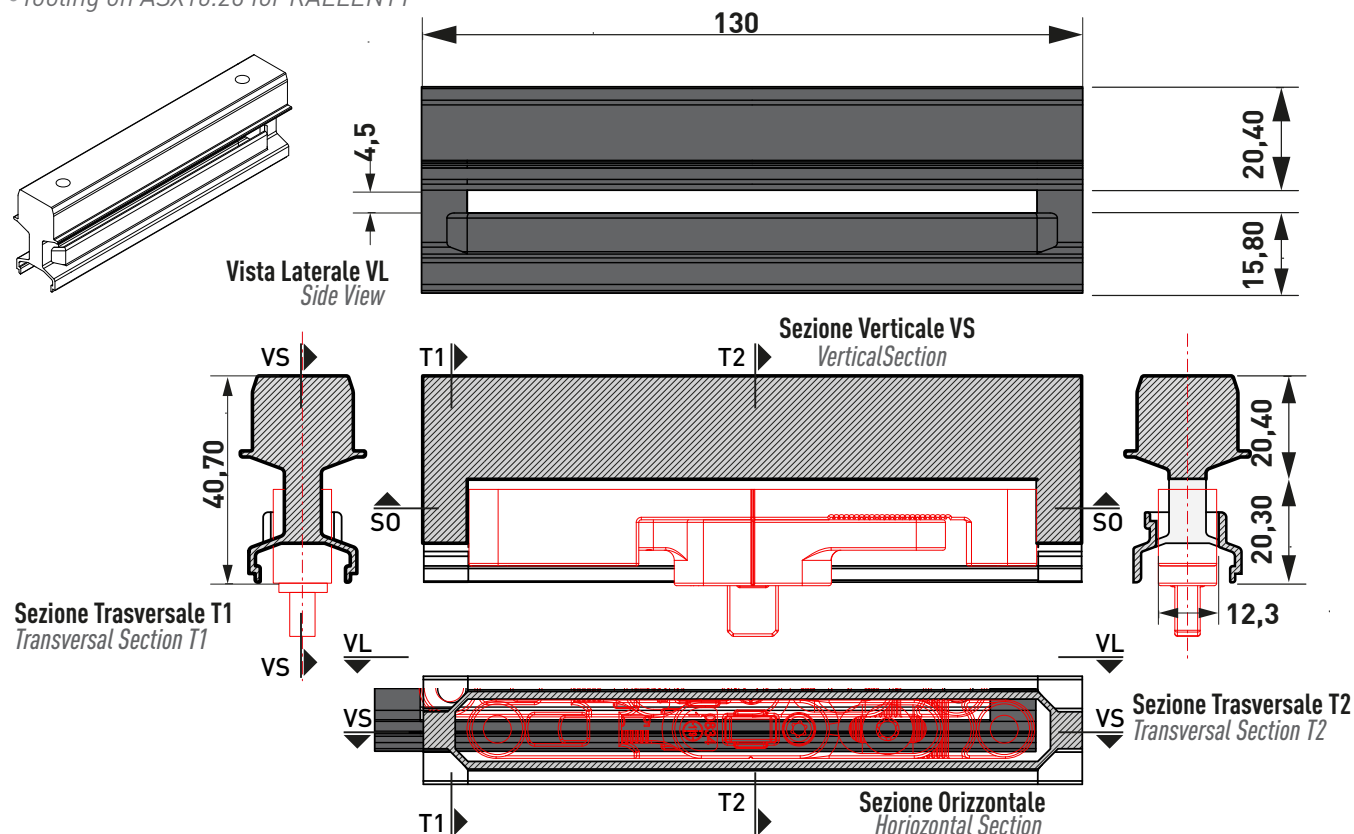

AHM 16.6744.2

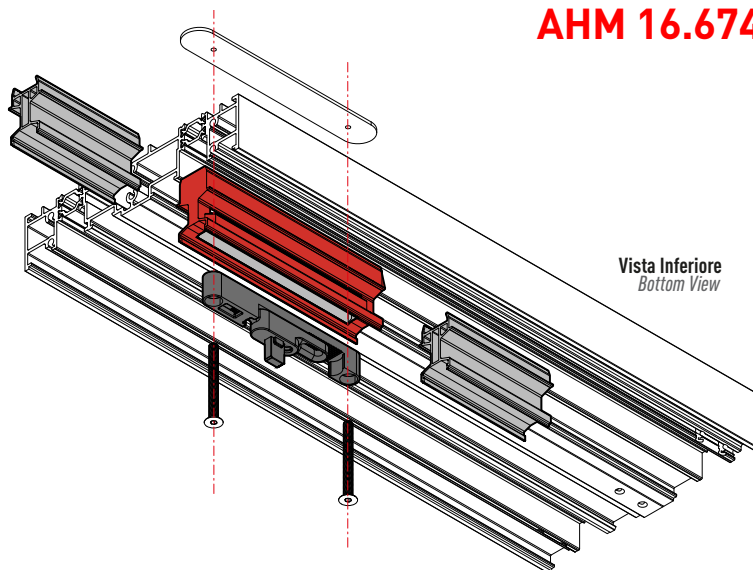

ANTA
SASH

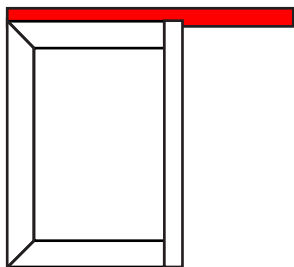

2 Scorrevoli
2 Sliding

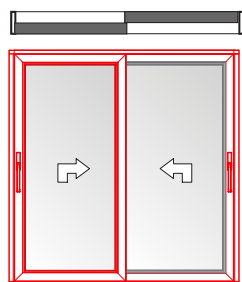

Anta | Sash 45°

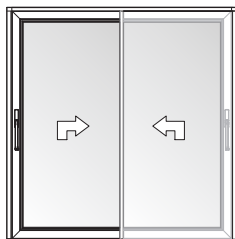

Anta | Sash 90°

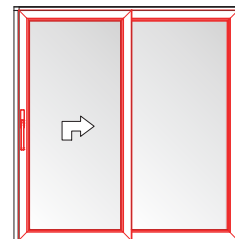

Anta | Sash 45°

1 Scorrevole
Sliding

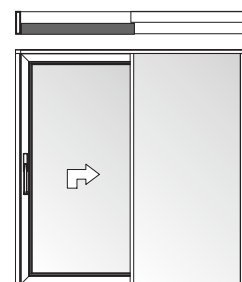

Anta | Sash 90°

- Montaggio RALLENTY
- Assembling RALLENTY

Art. OPZIONALE
OPTIONAL item

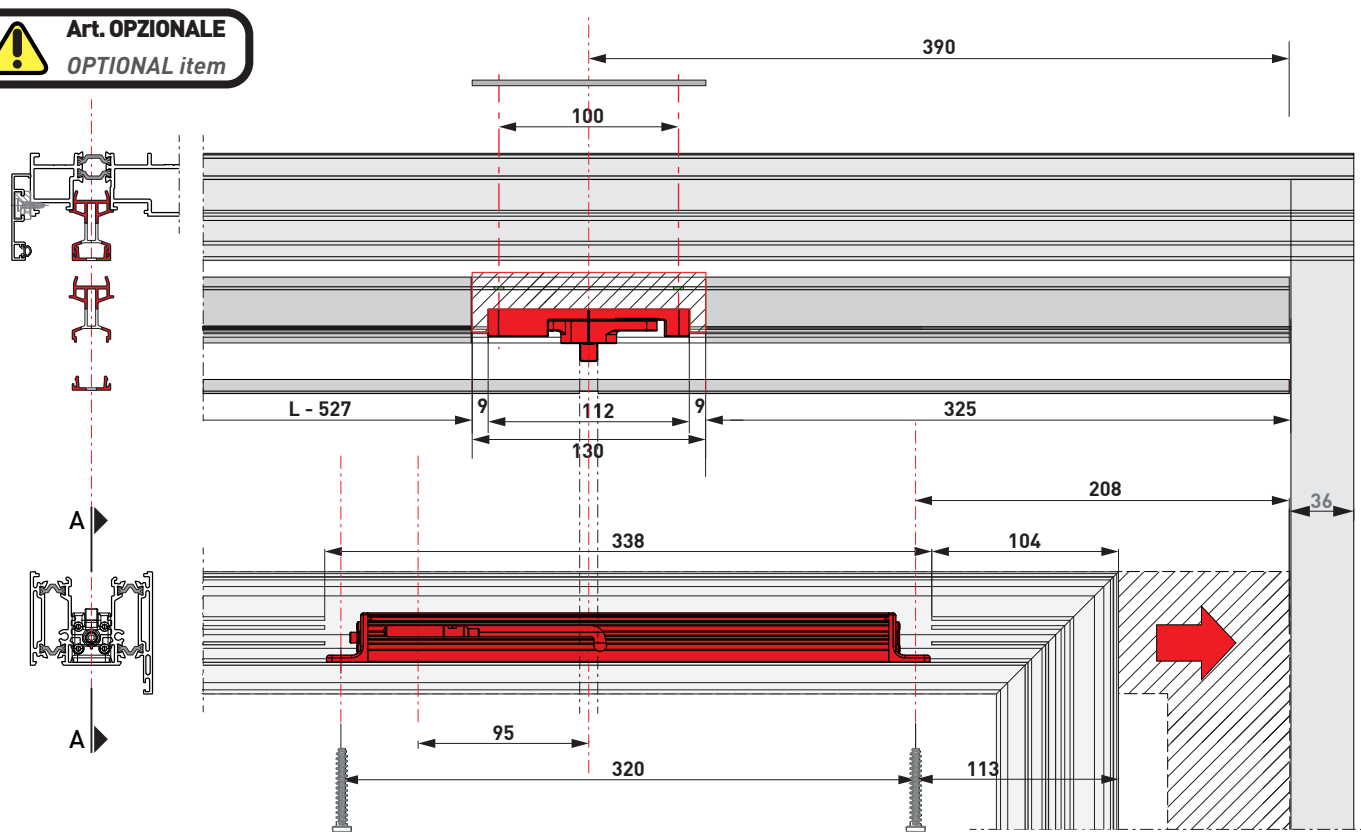

SEZ.: A-A

TAGLIO ARTICOLI ANTA CON RALLENTY CUTS for ITEMS PROFILES with RALLENTY

ART. Item	PROFILO Profile	DESCRIZIONE Description	MISURA Size	TIPO TAGLIO Cut Type	Ante Sash	
					1	2
BX49		Guida Superiore Upper Guide Rail	L - 527		1	2
			325		1	2
			130 [KIT RALLENTY]		1	2
ASX.10.26		Copriguida Rail Cover	L - 527		1	2
			325		1	2
			130		1	2

TAGLIO ARTICOLI ANTA SENZA RALLENTY CUTS for ITEMS PROFILES without RALLENTY

BX49		Guida Superiore Upper Guide Rail	L - 72		1	2
ASX.10.26		Copriguida Rail Cover	L - 72		1	2

ANTA

- SASH
- RALLENTY Assemblaggio
- RALLENTY Assembling

2 Scorrevoli
2 Sliding

1 Scorrevole
Sliding

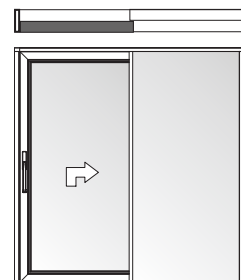
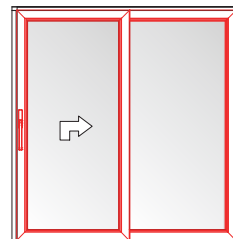
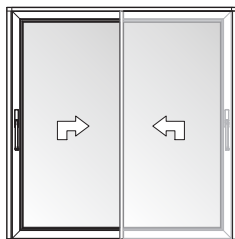
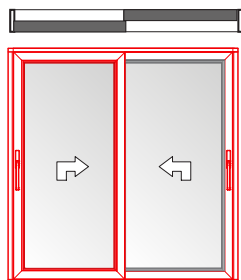

Anta | Sash 45°

Anta | Sash 90°

Anta | Sash 45°

Anta | Sash 90°

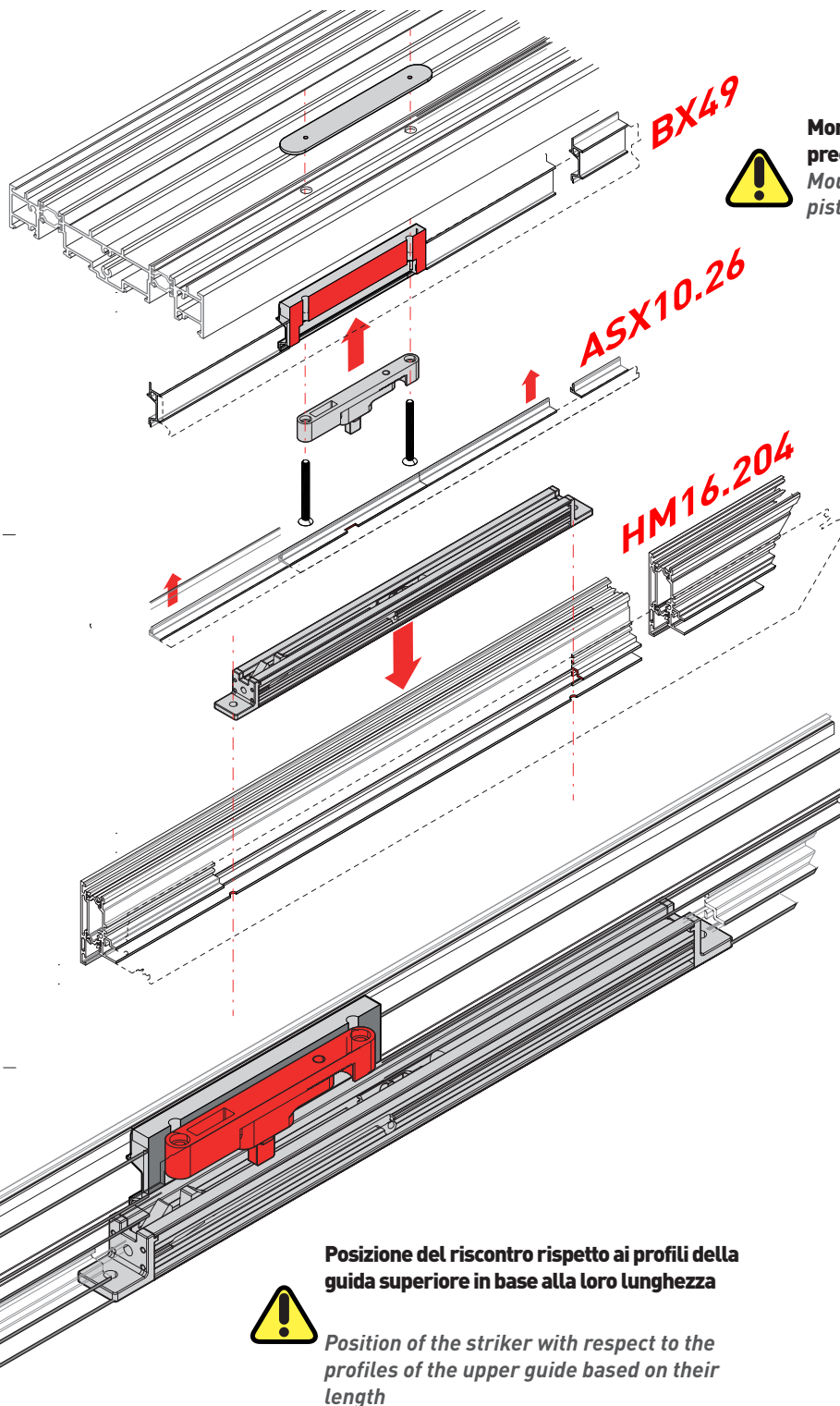
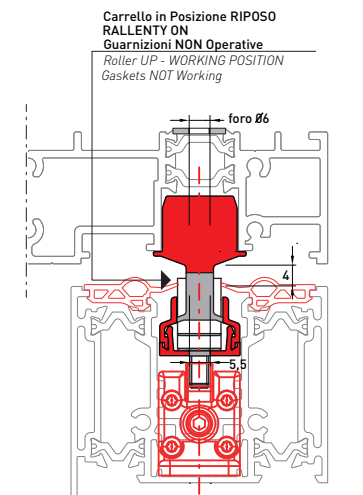
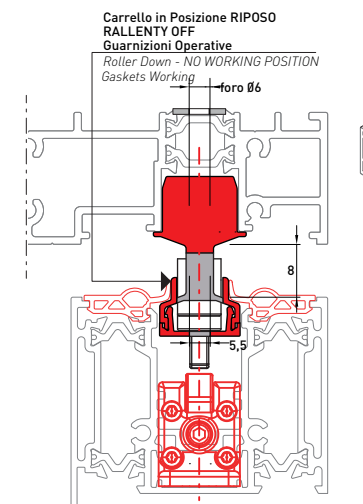

Montare con pistone precaricato
Mount with pre-loaded piston



Posizione del riscontro rispetto ai profili della guida superiore in base alla loro lunghezza

Position of the striker with respect to the profiles of the upper guide based on their length

ANTA

SASH

Asta di Collegamento | Posizione VERTICALE
Connection Rod | VERTICAL Position

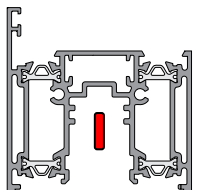

Mobile + Mobile
Sliding + Sliding

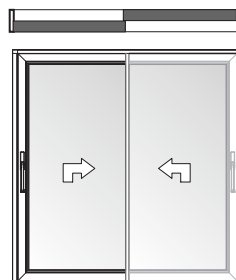

Mobile + Vetrata
Sliding + Glaze

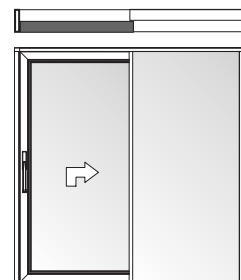

Anta | Sash 90°

Campo di applicazione HS Carrello 250kg Scope of application HS Trolley 250kg

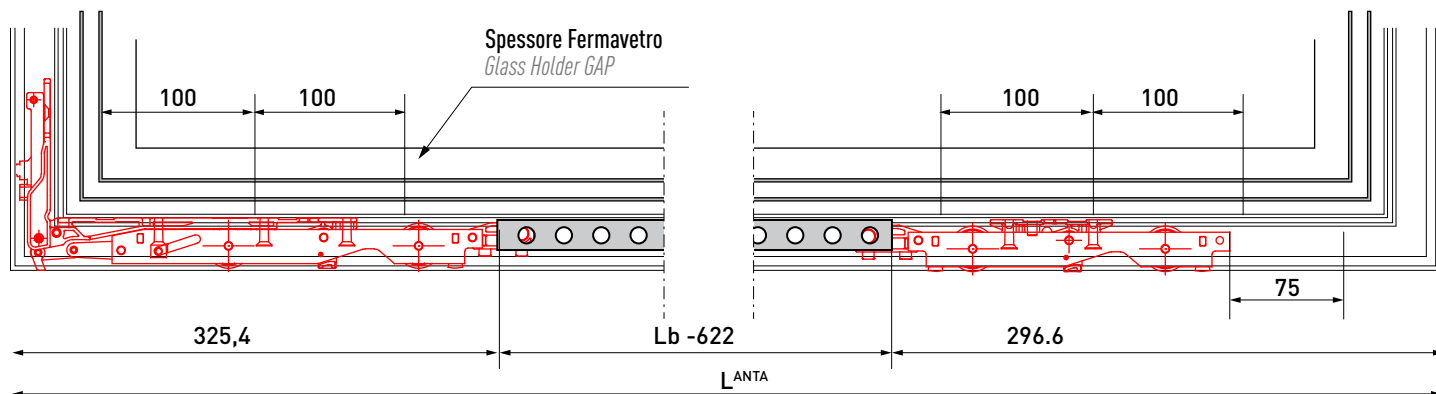

Campo di applicazione HS Carrello 400kg
Scope of application HS Trolley 400kg

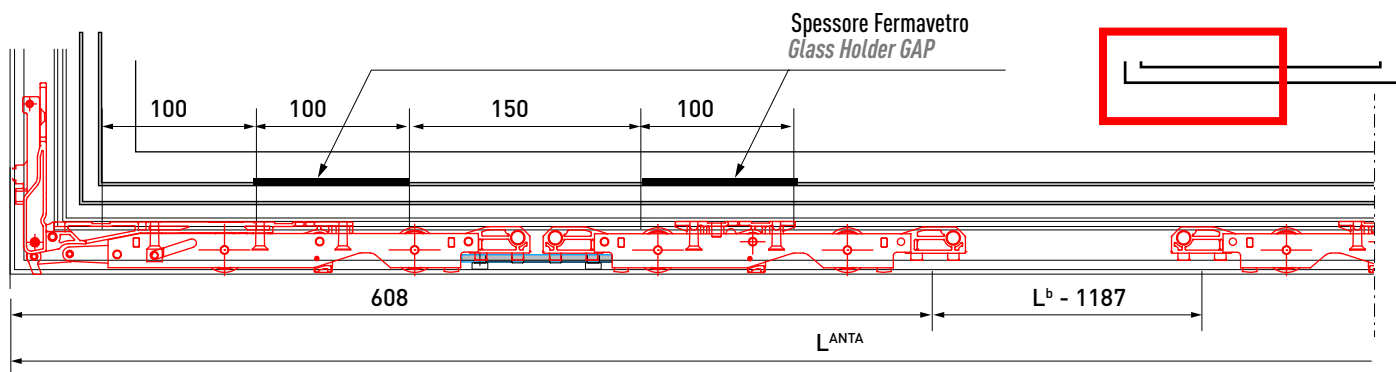

Per pesi elevati collegare il carrello all'anta scorrevole per mezzo di un perno.
For heavy weights, connect the carriage to the sliding leaf by means of a pin.

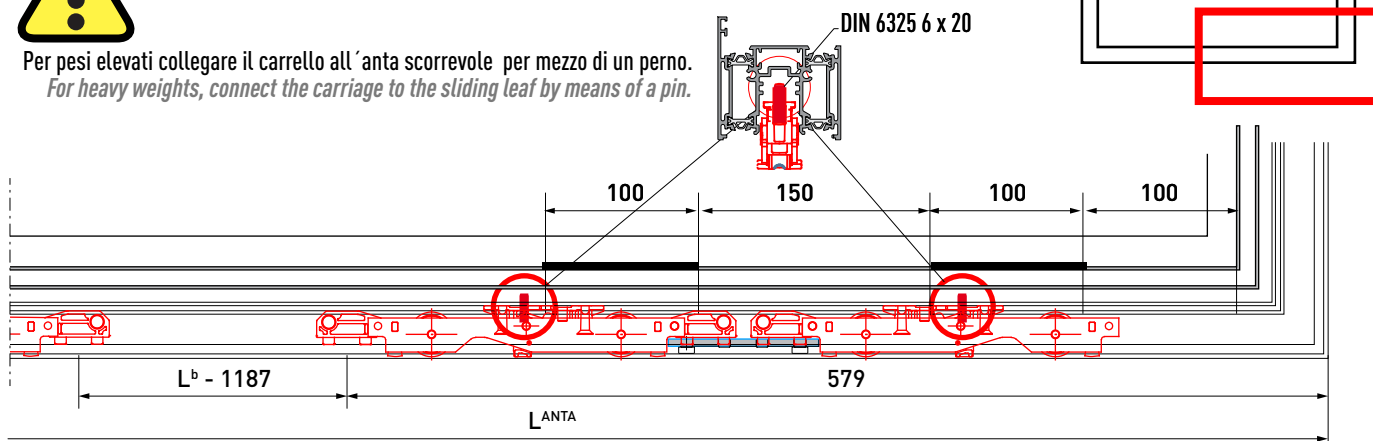



ANTA

SASH

• KIT AHM16.6745.73 ANTIEFFRAZIONE

• KIT AHM16.6745.73
ANTI-BURGLARY

Rif cert. RC3 n° 0873RP

Mobile + Fisso
Sliding + Fixed

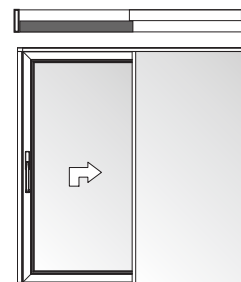

Anta | Sash 90°

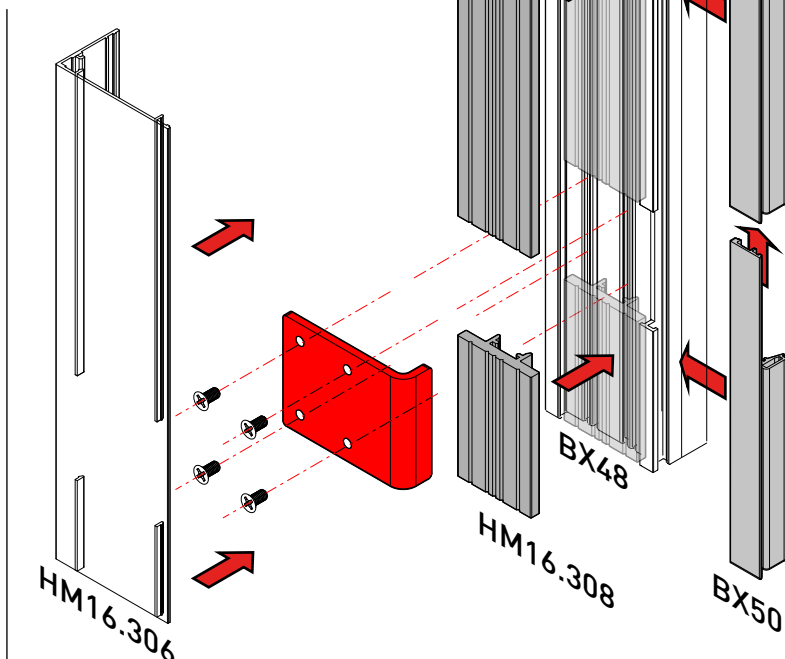
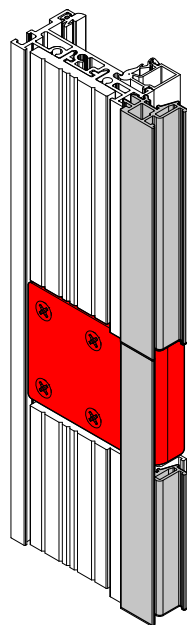
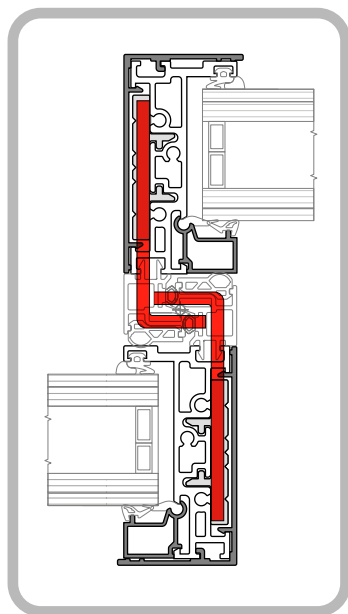
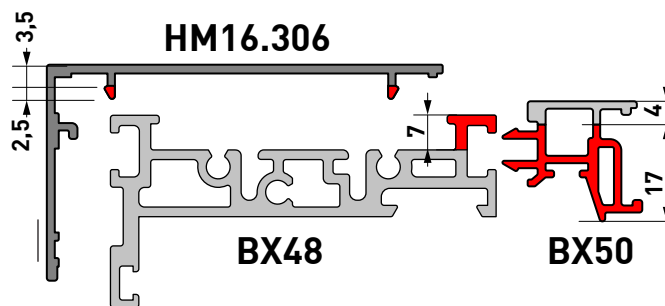
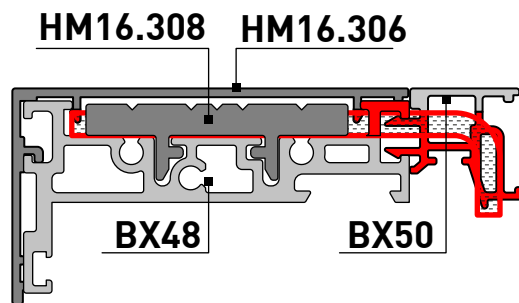
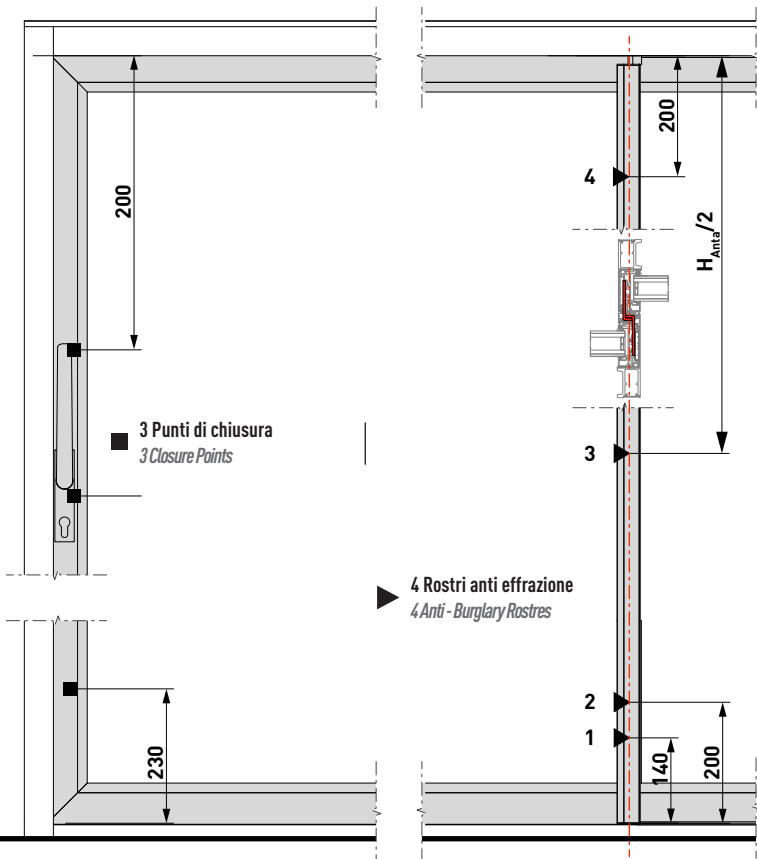



ANTA

SASH

• KIT AHM16.6745.73 ANTIEFFRAZIONE

• KIT AHM16.6745.73
ANTI-BURGLARY

Rif cert. RC3 n° 0873RP

Mobile + Fisso
Sliding + Fixed

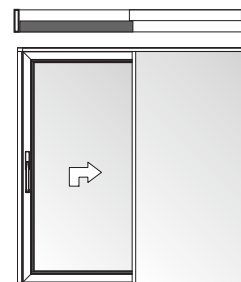

Anta | Sash 90°

MONTANTE CENTRALE ANTA
MOBILE SASH CENTRAL MULLION

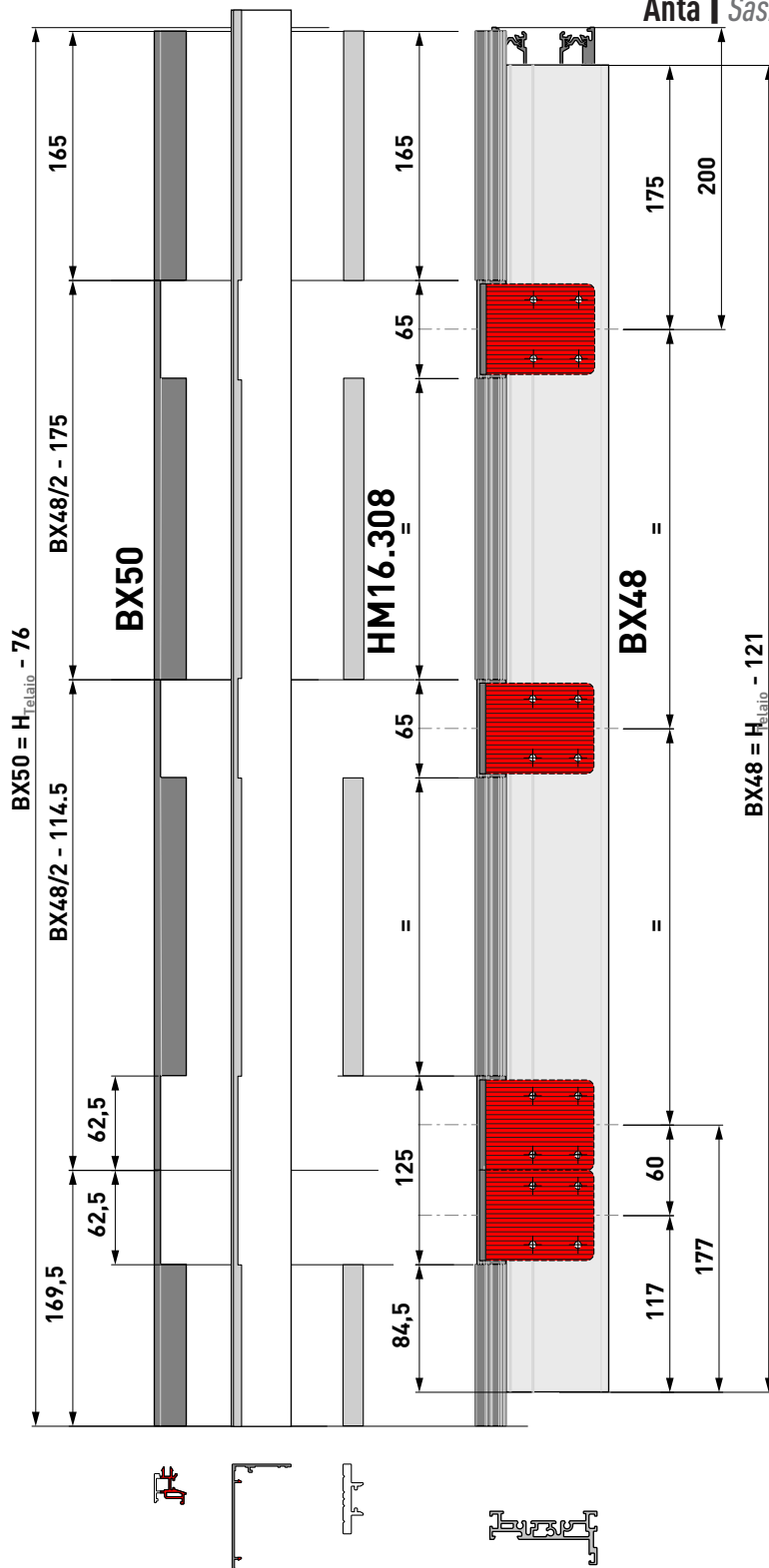
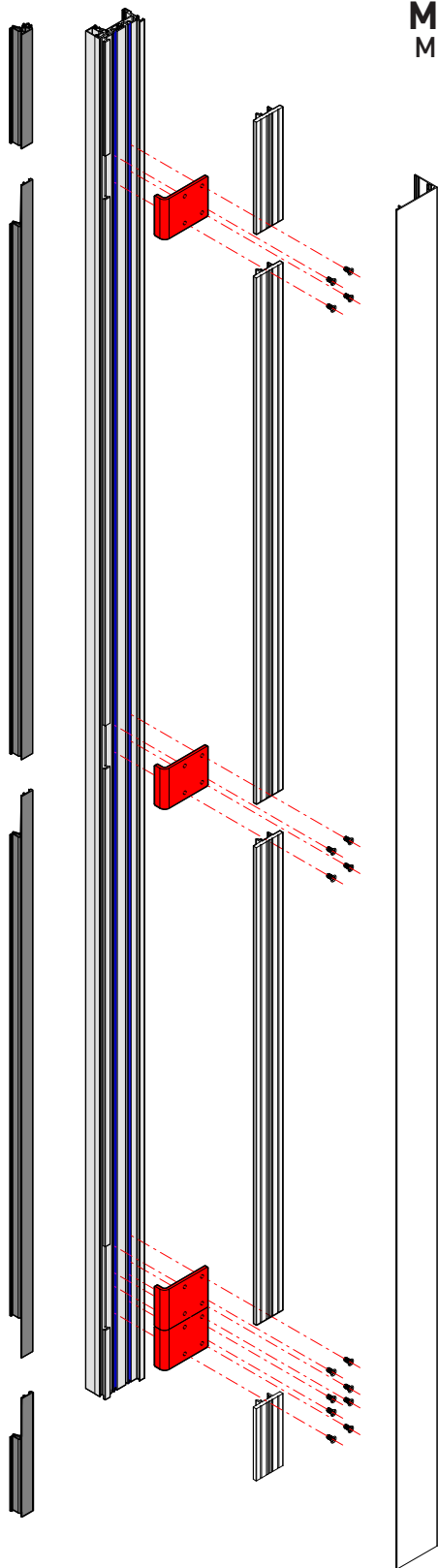

ANTA

SASH

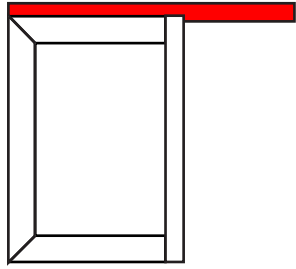

- Assemblaggio Guida Anta BX49
- Assembling Sash Rail BX49

1 Posizionamento su Anta di BX49
BX49 Installing on Sash

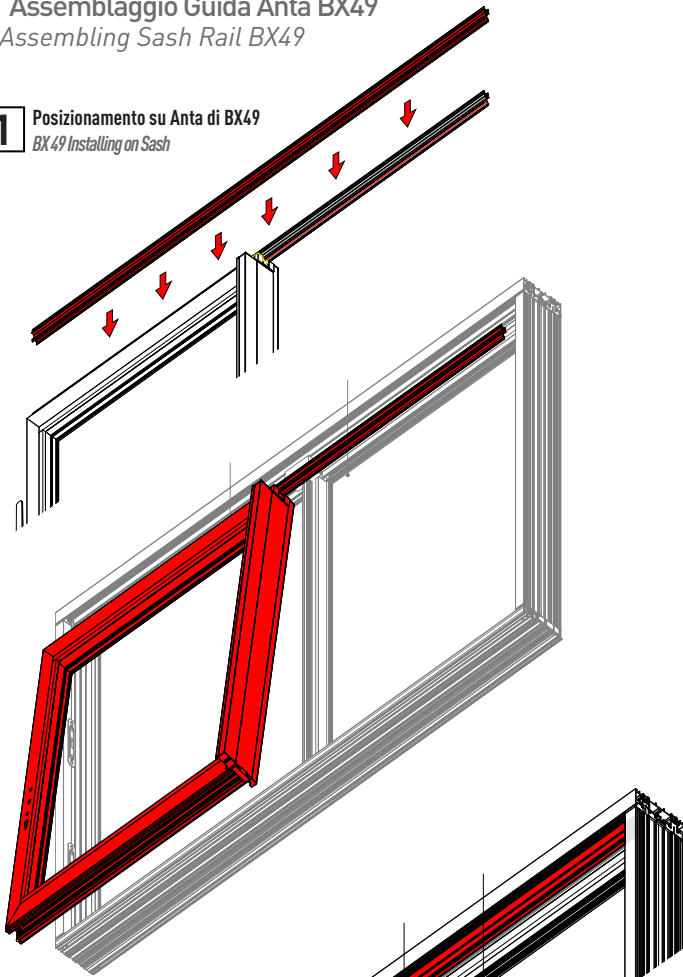

2 Inserimento Anta su Telaio
Inserting Sash in Frame

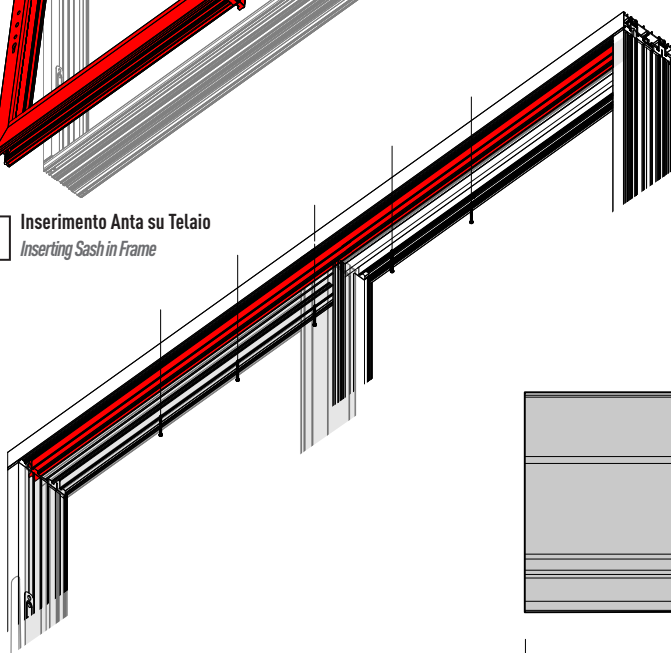

3 Fissaggio Guida BX49 su Telaio. Viti Passo 200 mm
Fixing Rail BX49 on Frame. Screw every 200 mm.

Mobile + Fisso
Sliding + Fixed

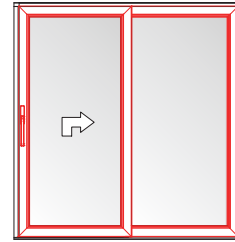

Anta | Sash 45°

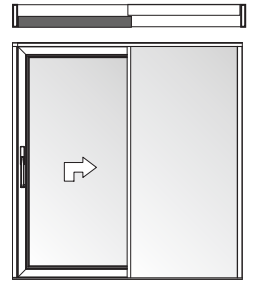

Anta | Sash 90°



4 Fissaggio carter HX16.504 su Telaio. dopo inserimento anta
Fixing carter HX16.504 on Frame. After insert Sash

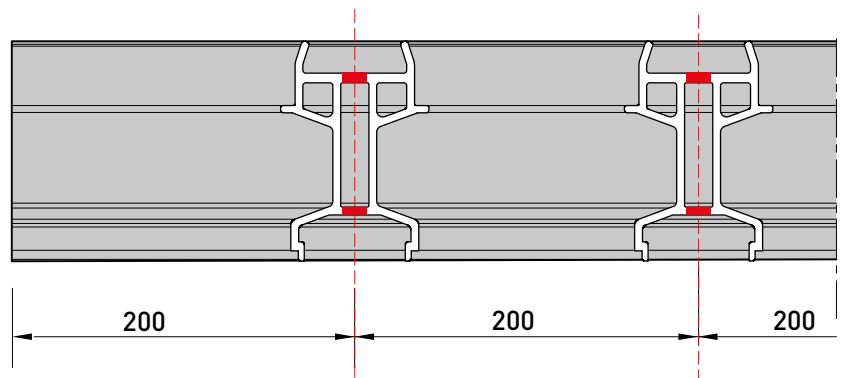
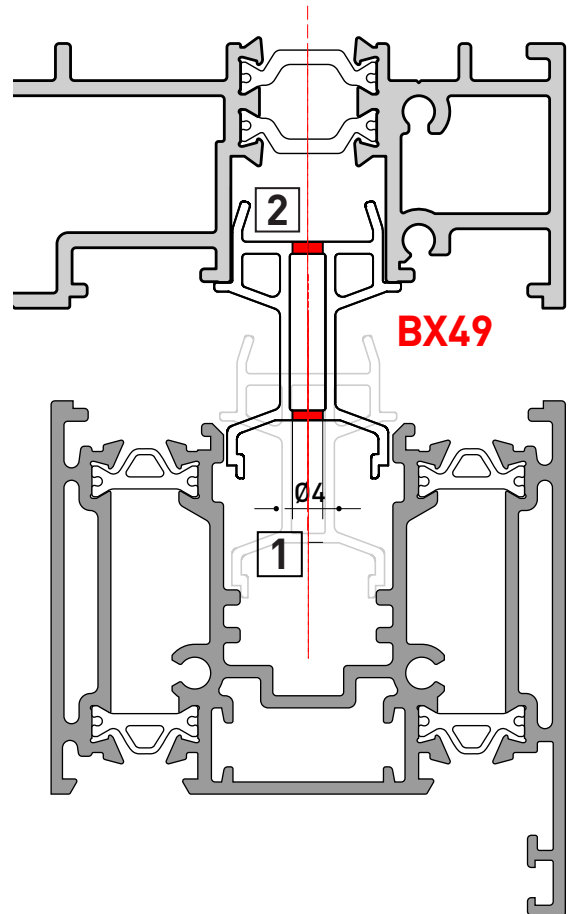



TELAIO
MAIN FRAME

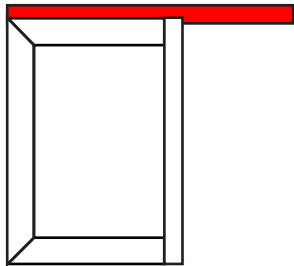

- Anta e BX49
- Sash and BX49

Mobile + Mobile
Sliding + Sliding

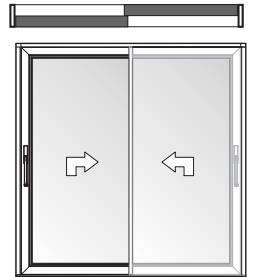
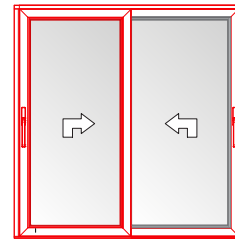

Anta | Sash 45°

Anta | Sash 90°

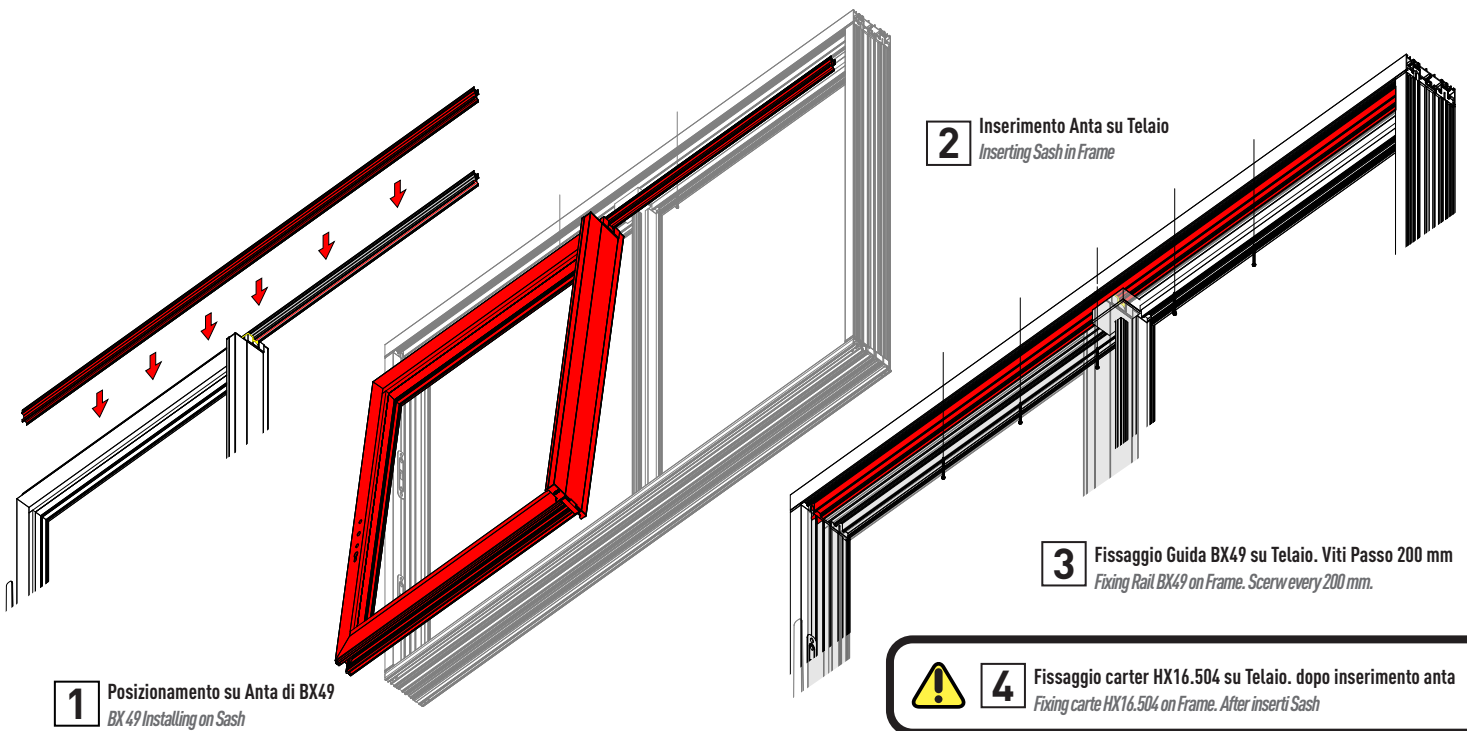
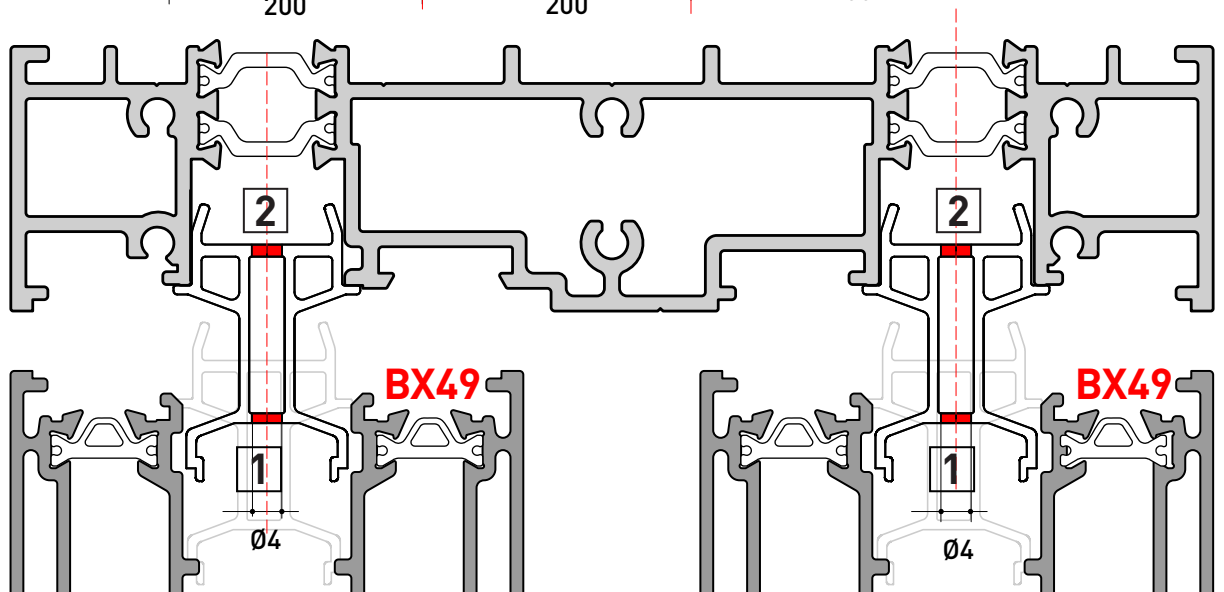
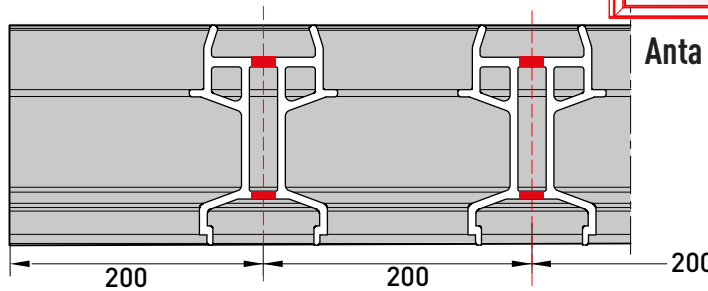

1 Posizionamento su Anta di BX49
BX 49 Installing on Sash

2 Inserimento Anta su Telaio
Inserting Sash in Frame

3 Fissaggio Guida BX49 su Telaio. Viti Passo 200 mm
Fixing Rail BX49 on Frame. Screws every 200 mm.



4 Fissaggio carter HX16.504 su Telaio. dopo inserimento anta
Fixing carter HX16.504 on Frame. After insert Sash

TELAIO ANGOLO 90°
MAIN FRAME 90° CORNER



Mobile + Mobile
Sliding + Sliding

Mobile + Fisso
Sliding + Fixed

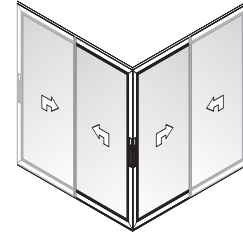

Anta | Sash 90°
Anta | Sash 45°

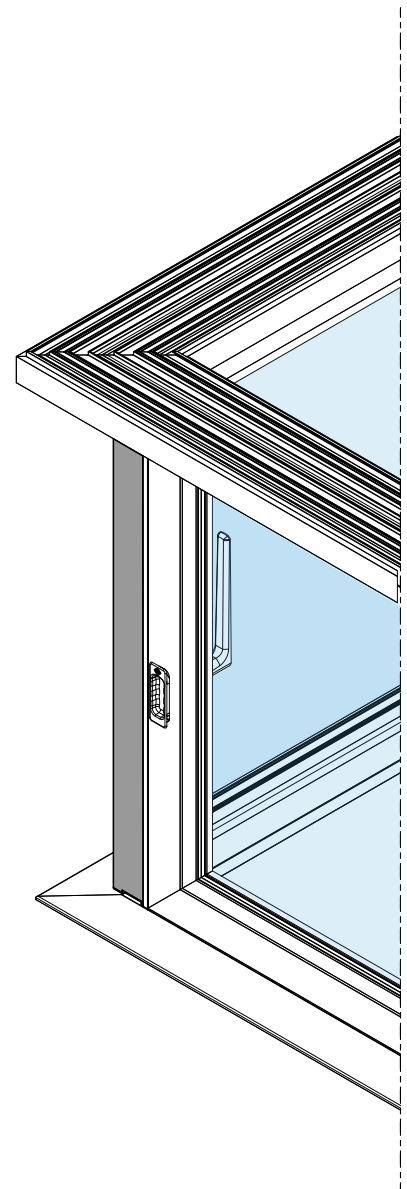
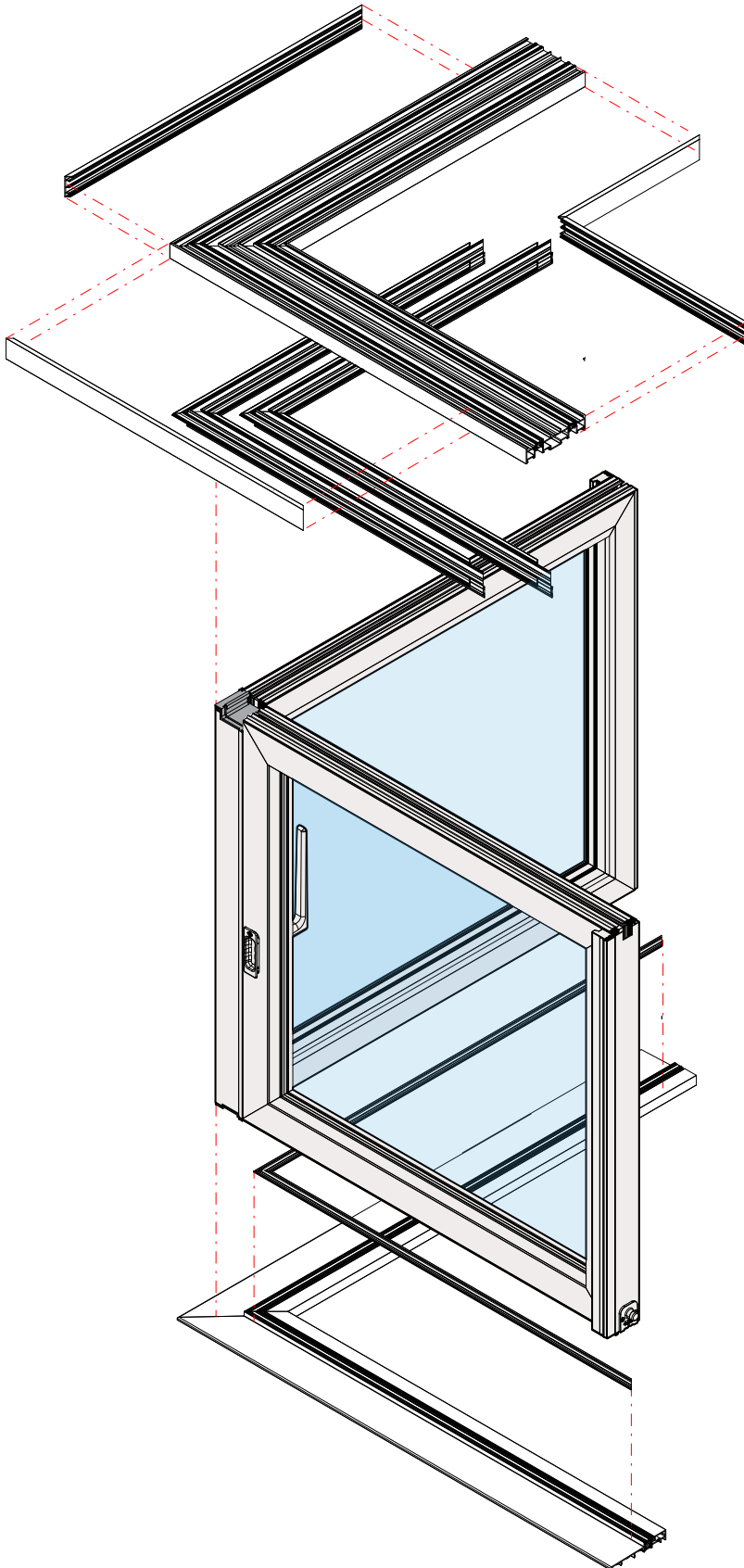



TELAIO ANGOLO 90°

MAIN FRAME 90° CORNER

- Lavorazioni su HM16.509
- Tooling on HM16.509

Mobile + Mobile
Sliding + Sliding

Mobile + Fisso
Sliding + Fixed

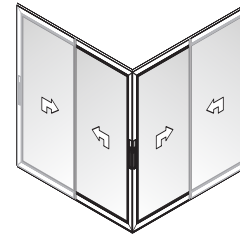

Anta | Sash 90°
Anta | Sash 45°

LATO SUPERIORE
UPPER SIDE

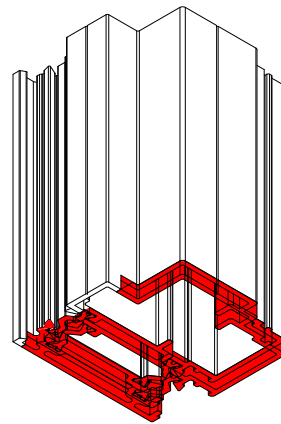
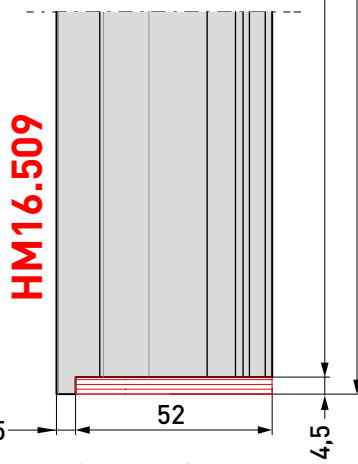
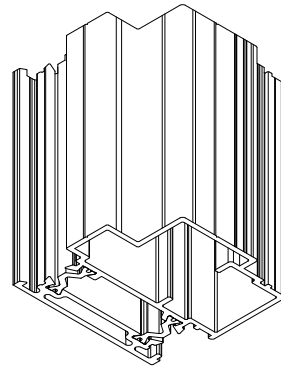
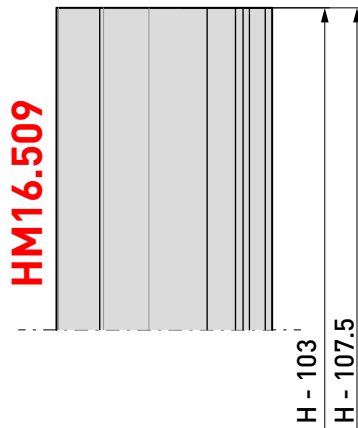

LATO INFERIORE
BOTTOM SIDE

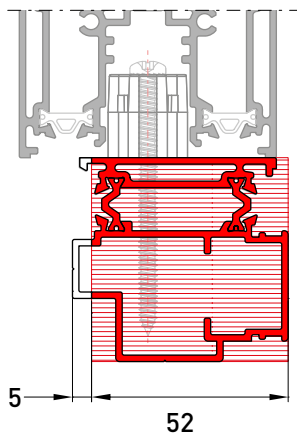

HM16.204

HM16.509



TELAIO ANGOLO 90°

MAIN FRAME 90° CORNER

- Lavorazioni su HM16.510
- Tooling on HM16.510

Mobile + Mobile
Sliding + Sliding

Mobile + Fisso
Sliding + Fixed

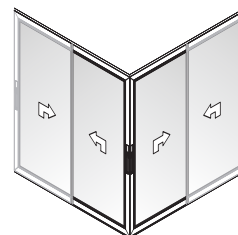

Anta | Sash 90°
Anta | Sash 45°

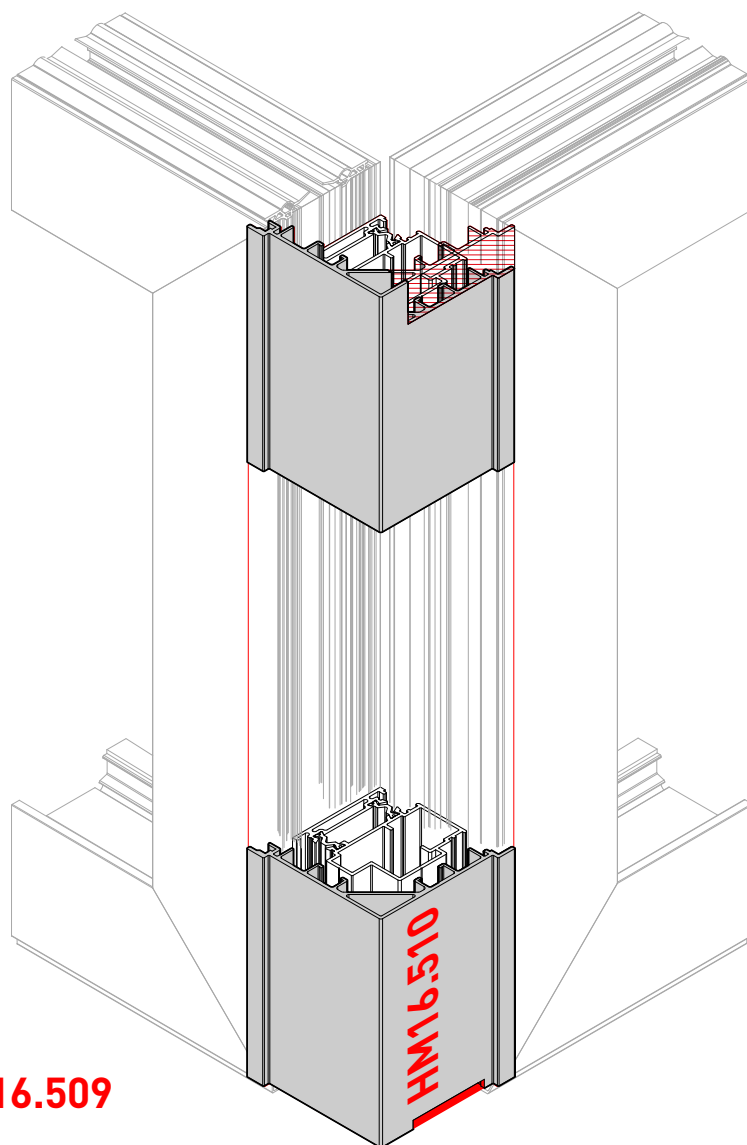
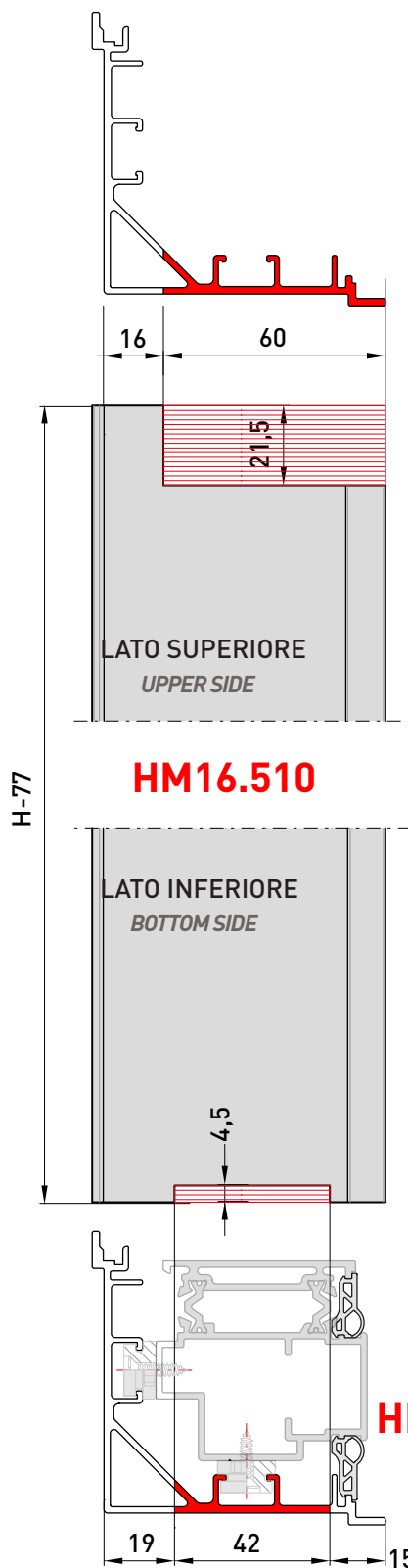

HM16.509

TELAIO ANGOLO 90°

MAIN FRAME 90° CORNER

- Montaggio Conf. AHM16.6745.78 + Acc.su HM16.510
- Assembling pack AHM16.6745.78 + Acc.es on HM16.509

Mobile + Mobile
Sliding + Sliding

Mobile + Fisso
Sliding + Fixed

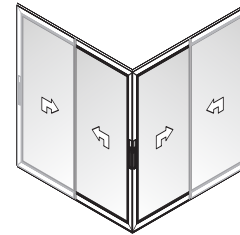

Anta | Sash 90°
Anta | Sash 45°

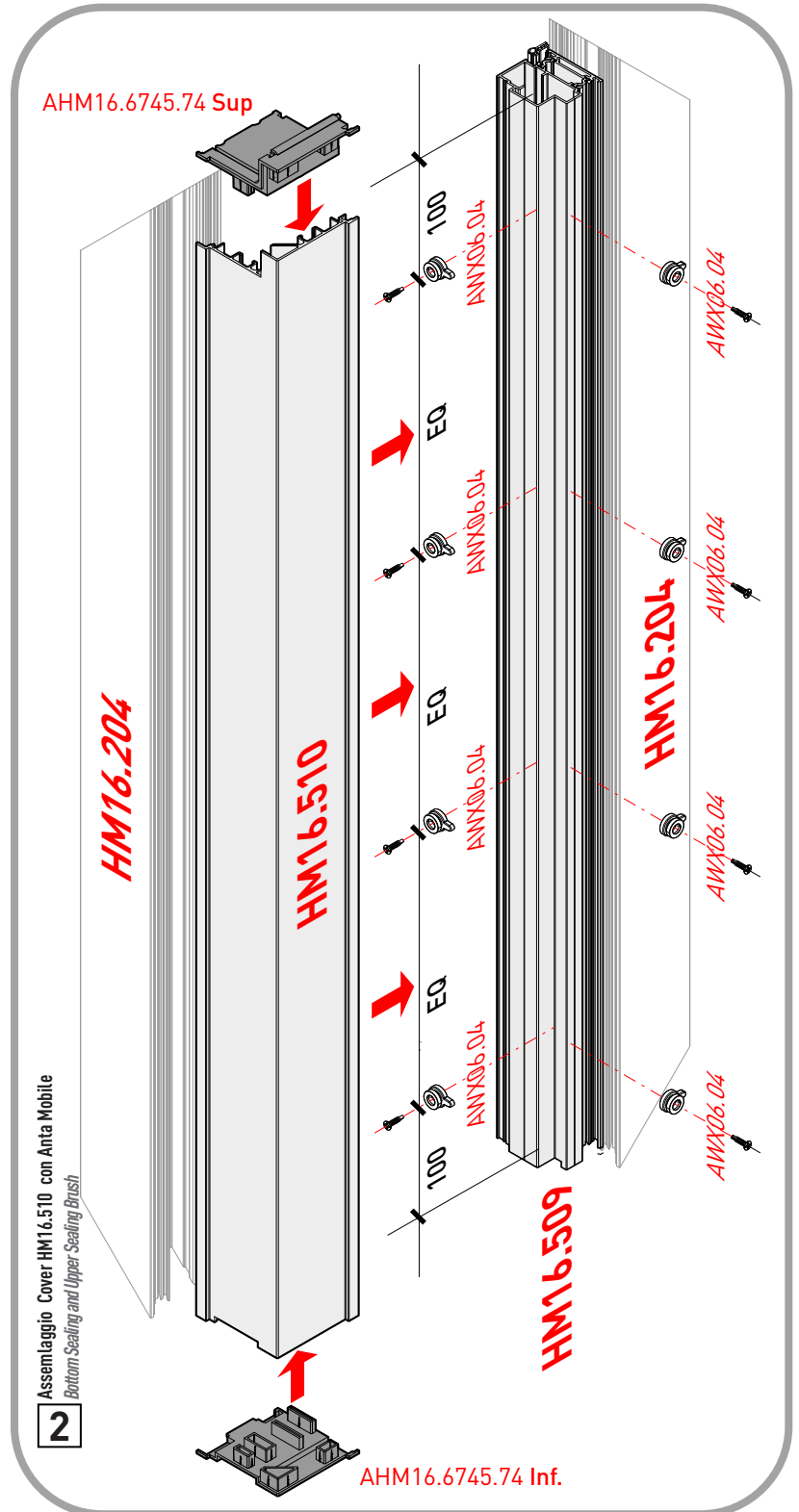
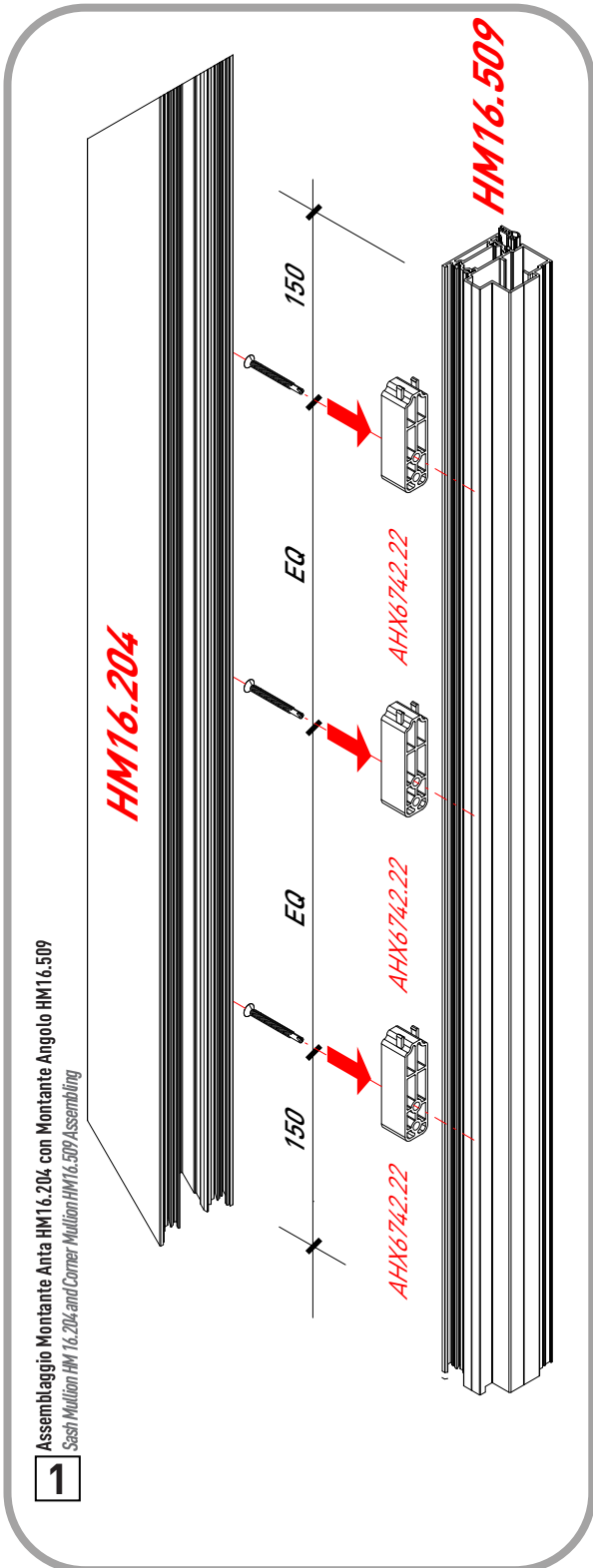

RIPORTO CENTRALE 4 ANTE
4 SASHES CENTRAL MULLION



Mobile + Mobile
Sliding + Sliding

Mobile + Fisso
Sliding + Fixed

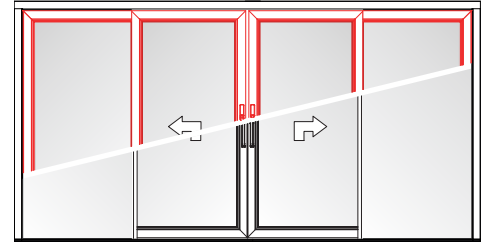

Anta | Sash **45°**

Anta | Sash **90°**

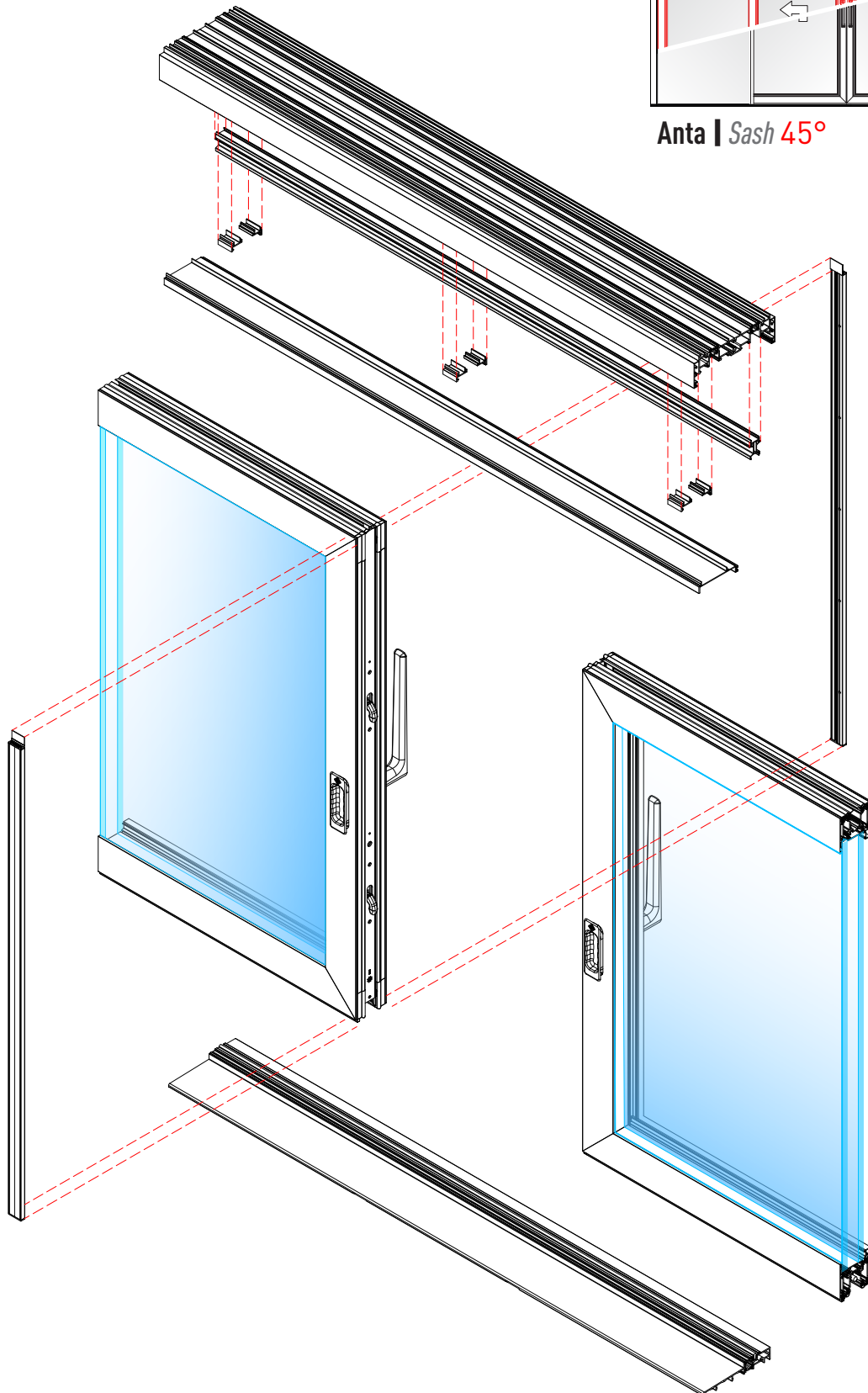

RIPORTO CENTRALE 4 ANTE
4 SASHES CENTRAL MULLION

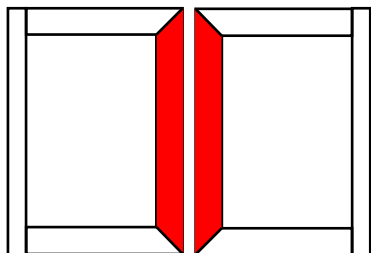

- Lavorazioni ASTA
- Tooling Handle ROD

Mobile + Mobile
Sliding + Sliding

Mobile + Fisso
Sliding + Fixed



Anta | Sash 45°

Anta | Sash 90°

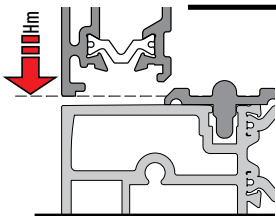
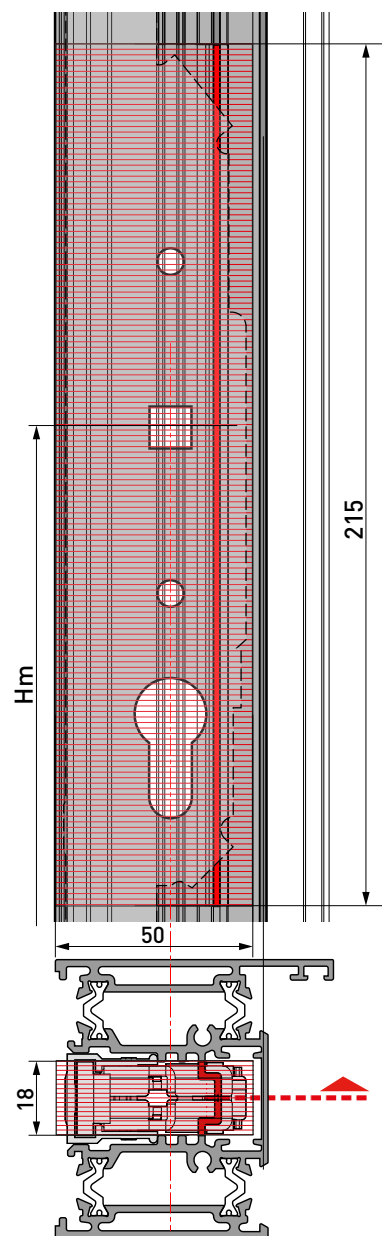
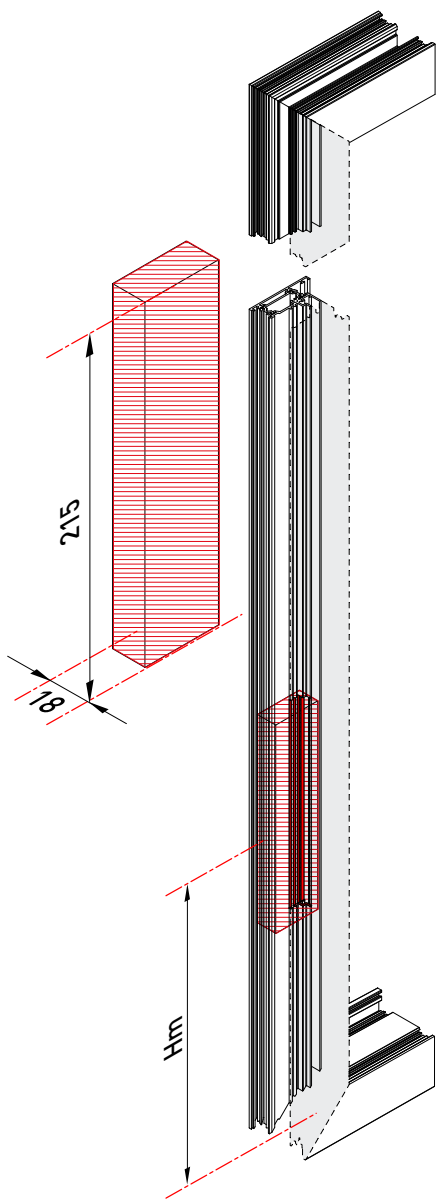
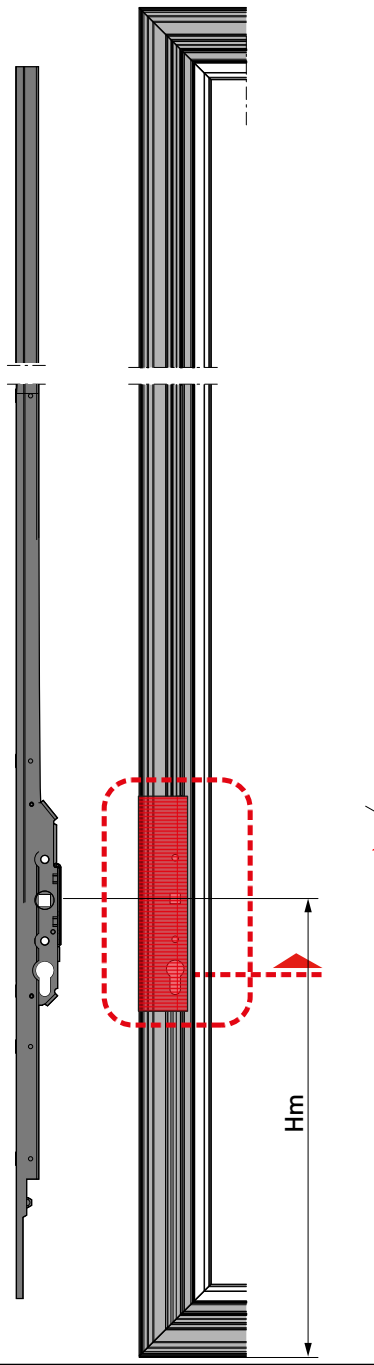

	HM16.6730.2	HM16.6730.3	HM16.6730.4	HM16.6730.5	HM16.6730.6	HM16.6730.7	HM16.6730.8
L Asta	1300	1700	2100	2500	2800	3300	3800
Hm	400.5	400.5	1000.5	1000.5	1000.5	1000.5	1000.5

RIPORTO CENTRALE 4 ANTE

4 SASHES CENTRAL MULLION

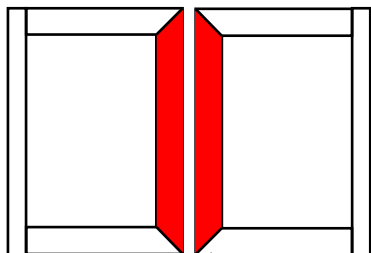

- Lavorazioni ASTA
- Tooling Handle ROD

Mobile + Mobile
Sliding + Sliding

Mobile + Fisso
Sliding + Fixed

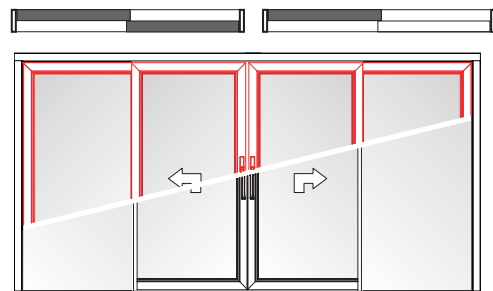

Anta | Sash 45°

Anta | Sash 90°

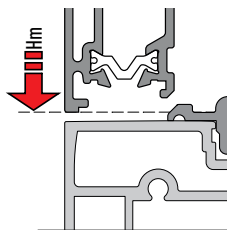
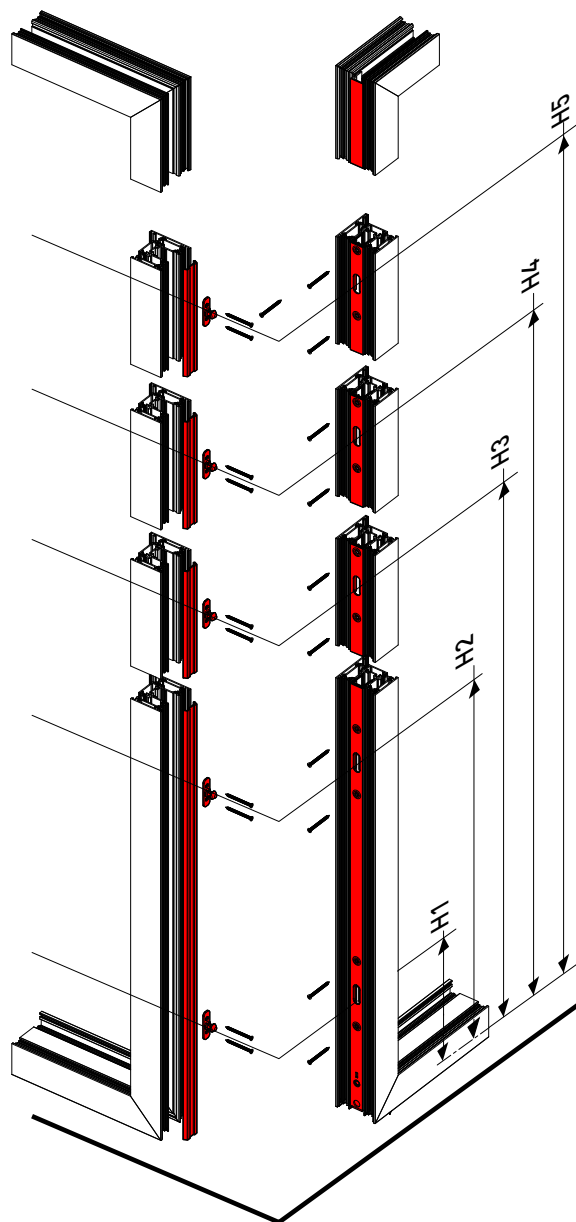
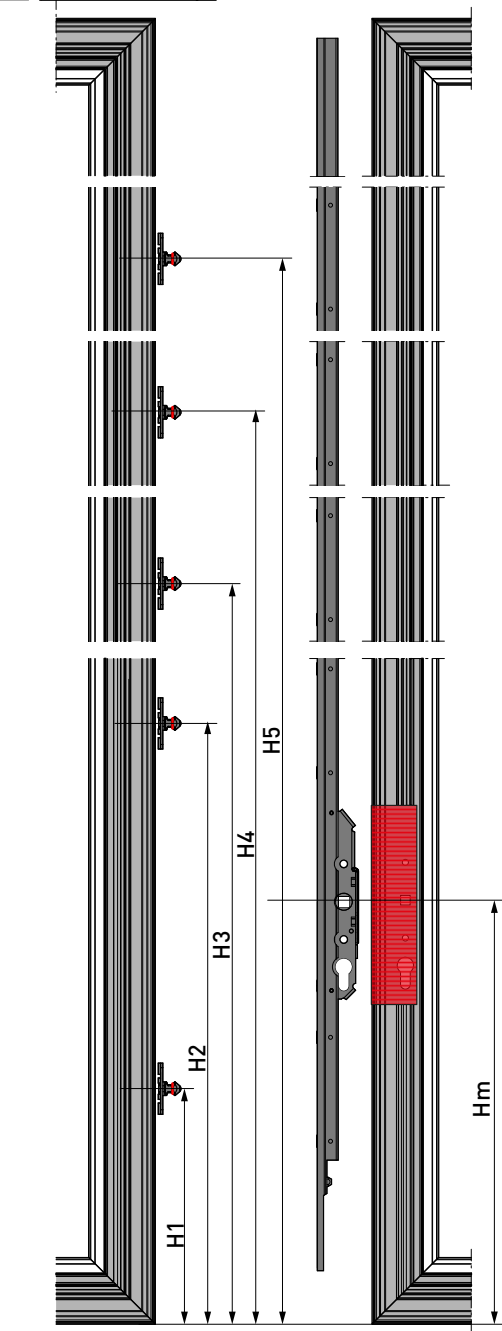

	HM16.6730.2	HM16.6730.3	HM16.6730.4	HM16.6730.5	HM16.6730.6	HM16.6730.7	HM16.6730.8
L Asta	1300	1700	2100	2500	2800	3300	3800
H1	200,5	200,5	200,5	200,5	200,5	200,5	200,5
H2	590,5	590,5	700,5	700,5	700,5	700,5	700,5
H3	-	1105	1190	1190	1190	1190	1190
H4	-	-	1505	1905	2305	1905	2305
H5	-	-	-	-	-	2705	3105

RIPORTO CENTRALE 4 ANTE

4 SASHES CENTRAL MULLION

- Installazione HM16.511
- Installation HM16.511

Mobile + Mobile
Sliding + Sliding

Mobile + Fisso
Sliding + Fixed

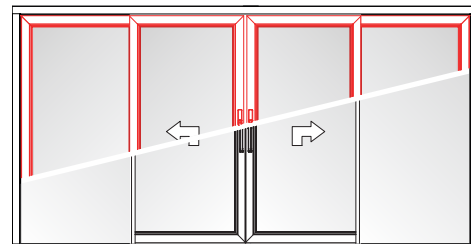

Anta | Sash 45°

Anta | Sash 90°

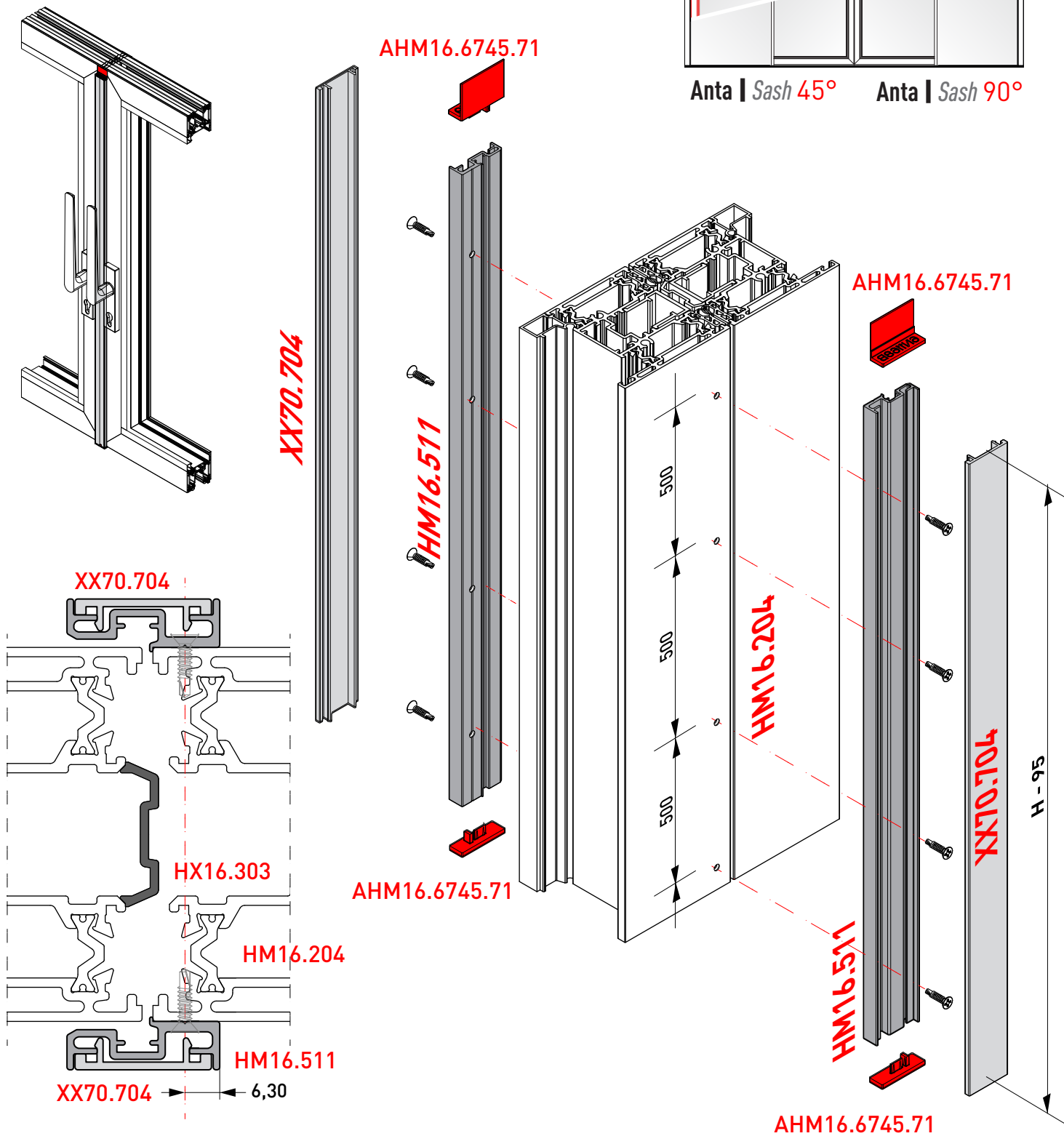

Gli archivi digitali dei prodotti TWIN SYSTEMS sono disponibili nei formati:

The digital files of the TWIN SYSTEMS products are available in the formats at:



www.twinsystems.it/web/richiesta-dwg

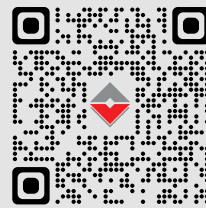

Il presente Catalogo assieme ai cataloghi di tutti i prodotti TWIN SYSTEMS sono liberamente scaricabili:

This Catalog together with the catalogs of all TWIN SYSTEMS products can be downloaded freely at:

www.twinsystems.it/professionisti/cataloghi/

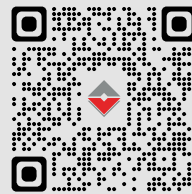

PAGINA Cataloghi
CATALOGUES Webpage

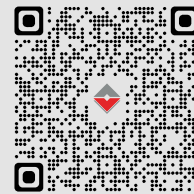

LINEA PRODOTTI
PRODUCTS Line

PAM SYSTEM S.r.L.

S.S. 230 - Fornace Crocicchio 13030 Formigliana (VC)
Tel. 0161 858811
www.pamsystemsrl.com | info@pamsystemsrl.com

ALQ GENOVA s.r.l.

Genova

Via Colano, 9/A 12/K 16162 Genova Bolzaneto (GE)
Tel. 010 7491941 - Fax 010 7450155

PAESANI GROUP

Direzione & Magazzino

Via del Grano, 260 47822 Santarcangelo di Romagna (RN)
Tel. 0541 748511
www.paesani.com - info@paesani.com

Magazzino Nord

Via Luigi Bonati, 21 29017 Fiorenzuola d'Arda (PC)
Tel. 0523 943138
magazzinonord@paesani.com

DIVA s.a.s

Via Po, 25 - Z.I. Sambuceto 66020 S.Giovanni Teatino (CH)
Tel. 085 4405210
www.camel-diva.com | info@camel-diva.com

EUROALL S.r.l.

Strada Comunale della Mola Saracena, 23 00065
Fiano Romano (RM)
Tel. 0765 455228/61
www.euroallslrl.it - info@euroallslrl.it

PROFILATI UMBRIA S.r.l.

Via Dei Tigli, 35 - 06083 Bastia Umbra (PG)
Tel. 075 8012385-075 8010328
profilatiumbria@virgilio.it

TSL ALLUMINIO S.r.l.

Via delle Industrie, 12 00030 San Cesareo (Roma)
Tel. 06 2251591 (Ric. Aut.)
www.tslalluminio.it - info@tslluminio.it

ALLCAR SERVICE S.r.l.

Via Acuto, 120 - 00131 Roma
Tel. 06 4130626 (Ric. Aut.)
allcarservice@mclink.it

ALLUCOM S.r.l.

Andria

Via Vecchia Barletta 237 Z. Ind. 76123 Andria (BT)
Tel. 0883 592213

Bari

Via Zippitelli, 28/B - 70123 (BA)
Tel. 0805058608
www.allucom.com - info@allucom.com

CARUSO S.r.l.

Z.I. Contrada Le Macere 86019 Vinchiaturo (CB)
Tel. 0874 340024
carusosrl1@libero.it

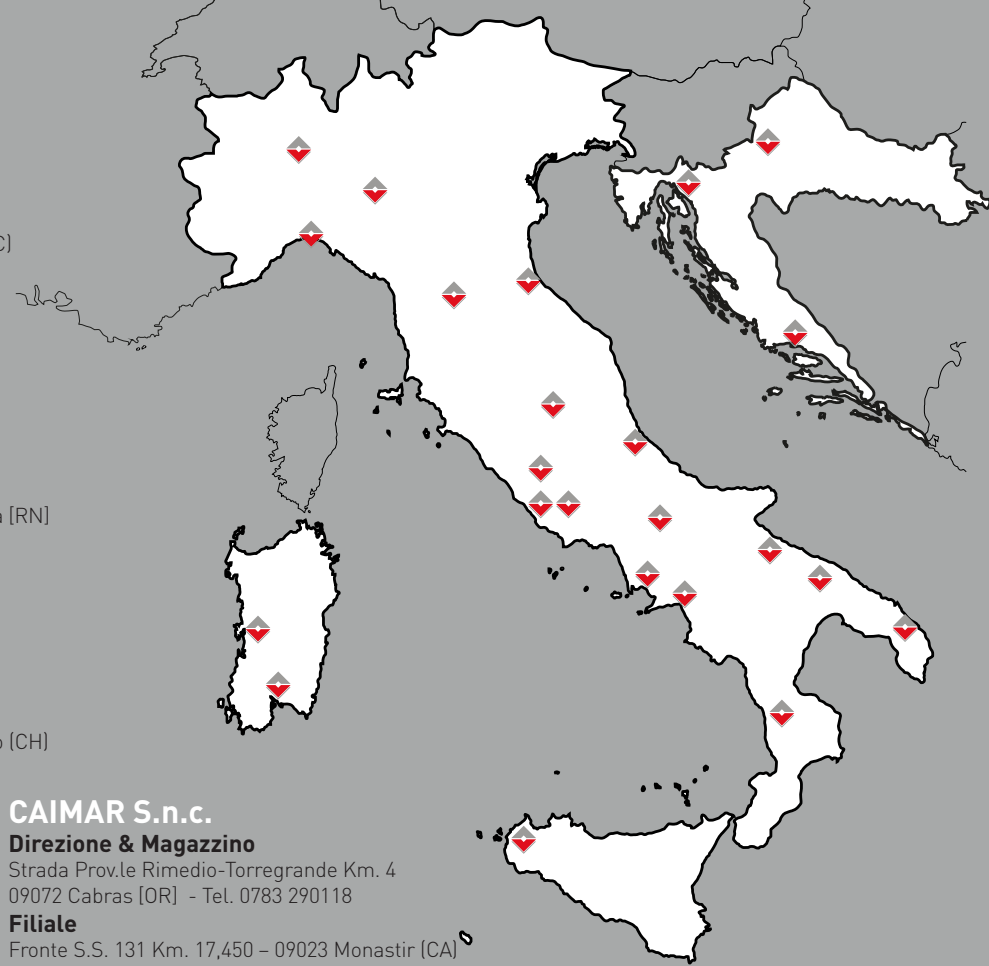

CAIMAR S.n.c.

Direzione & Magazzino

Strada Prov.le Rimedio-Torregrande Km. 4
09072 Cabras (OR) - Tel. 0783 290118

Filiale

Fronte S.S. 131 Km. 17,450 - 09023 Monastir (CA)
Tel. 070 9166020

www.caimar.it - caimarmail@caimar.it

SALENTO METALLI S.r.l.

Via Federico II, 13 - Zona PIP - 73020 Cavallino (LE)
Tel. 0832 614576

www.salentometalli.it - info@salentometalli.it

MIDA ALLUMINIO S.r.l.

Napoli

Via Piano del Principe, 36
80047 San Giuseppe Vesuviano (NA)
Tel. 081 5297373

Salerno

Loc. Terzerie, Z.I. - 80061 Ogliastro Cilento (SA)
Tel. 0974 833233
www.gruppomida.it - info@gruppomida.it

ITALBACOLOR S.r.l.

C.da Valle S. Maria - 87024 Fuscaldo (CS)
Tel. 0982 618025
www.italbacolor.it commerciale@italbacolor.it

COMAS S.r.l.

Via Porta Palermo, 84 - 91011 Alcamo (TP)
Tel. 0924 507050 - 0883 592213
www.comasgroup.it - info@comasgroup.it

ALUK TIM

Aluk Tim D.o.o.

Žegoti 10, 51215 Kastav Croazia, UE
Tel: +385 (0) 51/691 461

Filiale di Zagabria

Franje Lučića, 34A Zagabria Croazia, UE
Tel: +385 (0) 1 6462 611
Mob: +385 (0) 99 2939656
zagreb@aluk.hr

Filiale Spalato

Street Sv. Nikole Tavelića, 13A 21204
Dugopolje Croazia, UE
Tel: +385 (0) 21225525 |
Mob: +385 (0) 99 2199228
split@aluk.hr



  www.twinsystems.it
info@twinsystems.it

Consorzio TWIN SYSTEMS
Via delle Macere, 20 | 00060 Formello [Roma]
Tel./Fax 06 23260298