

SX85

SCORREVOLI MINIMALI
CON TAGLIO TERMICO

*MINIMAL SLIDING WINDOWS
W/THERMAL CUT*



TWIN
SYSTEMS

ARCHITETTURE IN ALLUMINIO

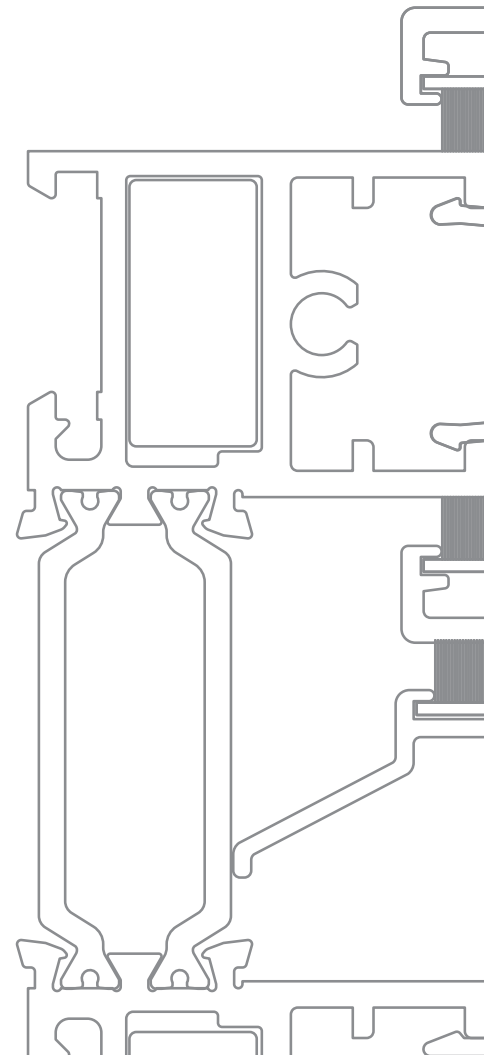

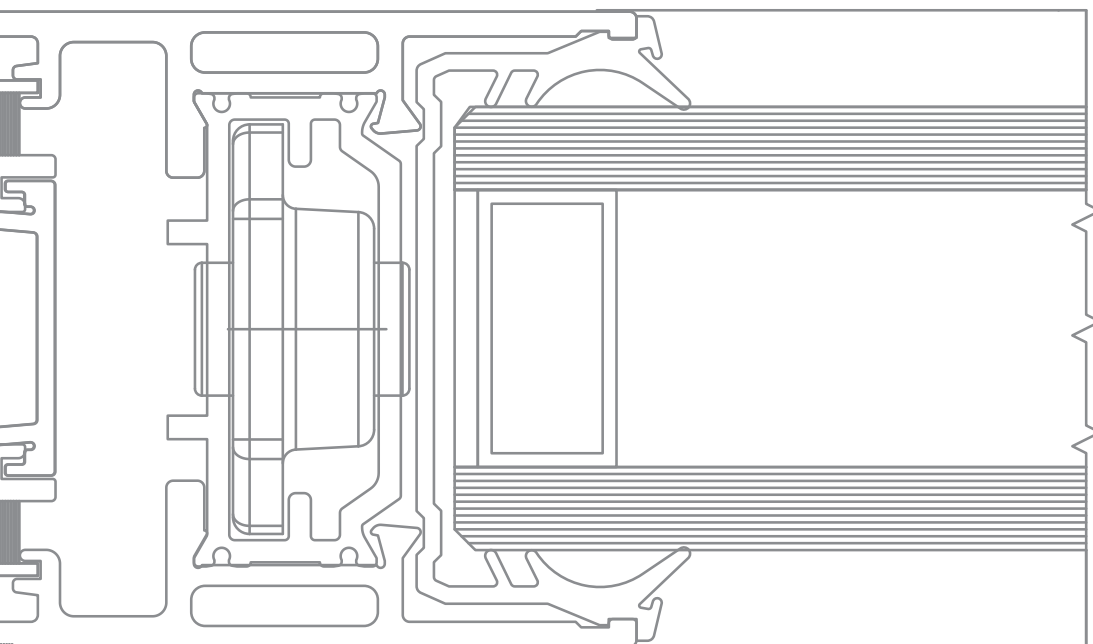

SX85

SCORREVOLI MINIMALI
CON TAGLIO TERMICO

*MINIMAL SLIDING WINDOWS
W/THERMAL CUT*





TWIN SYSTEMS

ARCHITETTURE IN ALLUMINIO



Gruppo A Informazioni Generali *Informazioni Generali*

Indice Generale
Caratteristiche Alluminio
Descrizione Tecnica sistema
Descrizione Tecnica Capitolato
Collaudi Prestazionali

*Table of Contents
Aluminium Characteristics
Technical Description
Technical Specifications
Performance Tests*

Gruppo B Profili *Profiles*

Elenco Profili
Profili Scala 1:1

*Profiles List
Profiles Scale 1:1*

Gruppo C Accessori e Guarnizioni *Accessories and Gaskets*

Elenco accessori
Elenco guarnizioni

*List of Accessories
List of Window Gaskets*

Gruppo D Nodi *Main Sections*

Sezioni principali
e Accessori
Sc. 1:1

*Main Sections and
Accessories
Scale 1:1*

Gruppo E Tipologie *Types*

Tipologie

Types

Gruppo F Attacco alla Muratura *Wall Joint*

Sezione particolareggiata
attacco alla muratura

Wall Joint Detail

Gruppo G Lavorazioni/Montaggi *Tooling/Assembly*

Schemi Lavorazioni
Frese
Attrezzatura

*Tooling Systems
Cutters Equipments
Milling*

Tutti i dati riportati sul presente catalogo sono indicativi e non impegnativi. La società si riserva il diritto di apportare in qualsiasi momento modifiche atte a migliorare i prodotti. Per informazioni tecniche riguardanti il catalogo contattare l'ufficio tecnico.

All the data shown in this catalog are indicative and not binding. The company reserves the right to make changes to improve the products at any time. For technical information regarding the catalog, contact the technical department.



Informazioni Generali
General Information

Gruppo A

Indice Generale	<i>Table of Contents</i>
Caratteristiche Alluminio	<i>Aluminium Characteristics</i>
Descrizione Tecnica sistema	<i>Technical Description</i>
Descrizione Tecnica Capitolato	<i>Technical Specifications</i>
Collaudi Prestazionali	<i>Performance Tests</i>

**PESO PROFILATI**

Il peso indicato è quello teorico e potrà variare in funzione delle tolleranze di spessore e dimensionali dei profilati (NORMA UNI EN 12020-2)

LEGA DI ESTRUSIONE

I profilati sono estrusi in lega EN-AW-6060 (UNI EN 573/3)

DIMENSIONI DEI PROFILATI

Le dimensioni indicate sono quelle teoriche, potranno quindi variare in funzione delle tolleranze dimensionali di estrusione (norma UNI EN 12020-2). Questa variabilità che interessa tutti i profilati, può influire, anche se minimamente, sulle dimensioni di taglio e quindi finali del serramento. Anche la verniciatura, aumentando gli spessori, contribuisce a far variare la dimensione dei profilati e, particolarmente, riduce lo spazio nelle sedi di inserimento delle guarnizioni e degli accessori.

DIMENSIONI DI TAGLIO E LAVORAZIONI

Le dimensioni teoriche di taglio e le quote delle lavorazioni indicate nel presente catalogo sono esatte, ovvero matematicamente corrette, in certi casi dovranno, nella pratica, essere adattate in base alla precisione ed al tipo di impostazione delle misure delle macchine utilizzate. È pertanto consigliabile nei primi lavori o nel caso di importanti quantità di serramenti effettuare delle campionature di prova.

PROTEZIONE SUPERFICIALE

Al fine di limitare i processi di corrosione filiforme è importante applicare le seguenti regole:

- ◆ Utilizzare accessori di assemblaggio in alluminio
- ◆ Utilizzare viti in acciaio inox
- ◆ Proteggere le parti tagliate e lavorate con prodotti idonei
- ◆ Evitare ristagni di condense all'interno dei profilati.

Per la realizzazione di serramenti è necessario attenersi alla tecnologia costruttiva e utilizzare le guarnizioni e gli accessori originali riportati sul catalogo tecnico e al rispetto delle norme, prescrizioni e raccomandazioni vigenti. L'osservanza di quanto sopra determina la garanzia. Su queste basi sono stati realizzati campioni che, collaudati in laboratorio hanno ottenuto i risultati indicati nelle certificazioni. Per il buon funzionamento e la durata degli infissi realizzati con profilati ed accessori del sistema, è necessario effettuare alcune semplici operazioni: una buona pulizia, eliminando residui di calce, cemento e/o altro.

È consigliabile peraltro proteggere il manufatto sino al momento della messa in esercizio, lubrificare con olio o grasso neutri le parti in movimento e gli organi di chiusura, controllare il corretto serraggio delle viti e dei grani, controllare gli assetti, registrandoli laddove sono previste regolazioni. Si raccomanda di effettuare queste operazioni almeno con cadenza semestrale. In caso di funzionamento anomalo di qualche componente, evitare assolutamente interventi atti a modificarne le caratteristiche e la sostituzione con ricambi non originali. Ci sembra utile ricordare che interventi di regolazione e/o sostituzione, con particolare riferimento ai meccanismi per oscillo-battente, andranno eseguiti da personale specializzato. Si raccomanda inoltre, in occasione delle operazioni di pulizia, di non utilizzare detergenti che possano deteriorare i trattamenti superficiali, escludendo tassativamente acidi, solventi, materiali abrasivi, spazzole metalliche o comunque in grado di scalfire le superfici, pagliette metalliche e altro.

DIMENSIONI E TIPOLOGIA DEI SERRAMENTI

La valutazione delle dimensioni dei serramenti, richiede la considerazione di vari fattori quali: il momento d'inerzia dei profilati, le dimensioni e il peso dei tamponamenti (vetri-pannelli), la larghezza e l'altezza delle parti apribili, caratteristiche e portate degli accessori, le condizioni e le quantità degli ancoraggi alle opere morte, l'esposizione, ecc... Fattori che sono valutabili e applicabili, grazie alla buona conoscenza dello stato dell'arte, alle informazioni riportate dai cataloghi, manuali tecnici e dalle normative vigenti. Consigliamo, al fine di evitare inutili contestazioni, di consultare il nostro servizio tecnico sistemi, prima di realizzare

WEIGHT OF PROFILES

The weight indicated is the theoretical one and may vary depending on the thickness and dimensional tolerances of the profiles (STANDARD UNI EN 12020-2)

EXTRUSION ALLOY

The profiles are made of extrusion alloy EN-AW-6060 (UNI EN 573/3)

DIMENSIONS OF PROFILES

The dimensions indicated are the theoretical ones; they may vary depending on the extrusion dimensional tolerances (STANDARD UNI EN 12020-2). This variability, which affects all the profiles, can affect, even if minimally, the cutting size and, therefore, the final size of the window. Also the coating, increasing the thickness, affects the size of the profiles and, in particular, reduces the space in the housing of window gaskets and accessories.

CUTTING AND TOOLING DIMENSIONS

The theoretical cutting and tooling sizes indicated in this catalogue are accurate, that is, they are mathematically correct. In practice, in some cases they may need to be adapted to take into consideration the precision and dimensional settings of the machines used. We therefore recommend that test samples be made in the first jobs or in the case of large quantities of windows.

SURFACE PROTECTION

The rules below should be followed to limit filiform corrosion phenomena:

- ◆ Use aluminium assembly accessories
- ◆ Use stainless steel screws
- ◆ Use appropriate products to protect cut and tooled parts.
- ◆ Prevent condensation from accumulating inside the profiles.

When making the windows, comply with the construction technology, use original window gaskets and accessories as listed in the technical catalogue and comply with applicable standards, provisions and recommendations. Non-compliance with the above rules invalidates the warranty. Samples have been made on these bases that, tested in the laboratory, have obtained the results indicated in the certifications. Some simple actions are necessary for the proper functioning and durability of window frames made with the system's profiles and accessories: good cleaning, eliminating traces of lime, cement, etc.

The product should be protected until the time of installation, lubricate moving parts and closing devices with neutral oil or grease, check that the screws and grub screws are tightened, check the trims, adjusting them where necessary. These operations should be carried out at least once every six months. Should any component not function correctly, do nothing to modify its characteristics and do not use non-original spare parts. Remember that adjustments and/or replacements, with special reference to tilt&turn mechanisms, must be carried out by specialized personnel.

During cleaning operations, detergents that can damage surface treatments - e.g. acids, solvents, abrasive materials, metal brushes or in any case able to scratch the surfaces, steel wool, etc. - should not be used.



serramenti che, per dimensione, forma, esposizione e/o altro possono essere ritenuti atipici. Le soluzioni e le combinazioni proposte in questo catalogo, non hanno carattere limitativo, ma presentano solo le situazioni e combinazioni più comunemente riscontrabili nella realtà. Soluzioni e combinazioni diverse, così come l'adozione di componentistica particolare, ad esempio meccanismi per la realizzazione di ante scorrevoli parallele, ante scorrevoli a libro o altro, sono possibili. A questo proposito il nostro servizio tecnico prodotti per l'edilizia può valutare e proporre le soluzioni più idonee.

DIMENSIONS AND TYPE OF WINDOWS

Various factors must be taken into consideration when assessing the dimensions of the windows, such as: the moment of inertia of the profiles, the dimensions and weight of the panels (glass-panels), the width and height of the opening parts, the characteristics of the accessories, the condition and number of fastenings to the dead work, the exposure, etc. These factors can be assessed and applied, thanks to the good knowledge of the state of the art and to the information reported in catalogues, technical manuals and current regulations.

In order to avoid needless complaints, we invite you to contact our technical service before making windows that, due to their size, shape, exposure and/or other characteristic, could be considered non-standard. The solutions and combinations proposed in this catalogue are not the only ones available, but merely represent the most common situations and combinations. Different solutions and combinations, as well as the use of particular components, for example mechanisms for parallel sliding doors, folding sliding doors etc., are available. In this regard, our building products technical service can study and propose the most suitable solutions.

COMPOSIZIONE PROFILATI

I profilati per serramenti saranno in lega di alluminio ENAW 6060 (EN 573-3 e EN 755-2) con stato fisico di fornitura UNI EN 515. I telai fissi e le ante mobili dovranno essere realizzati con profilati con ponte termico a tre camere (profilo interno ed esterno tubolari, collegati tra di loro con barrette in poliammide PA6.6 rinforzate con fibra di vetro).

INFISSI

Le finestre scorrevoli e le porte finestre scorrevoli dovranno avere un profilato di telaio fisso con profondità di 85 mm. (in alternativa di mm. 60.3 per mono-anta e mm. 145 per 3 ante) ed un profilato di anta mobile con profondità minima 46 mm. I profilati di telaio fisso inferiore dovranno avere la possibilità di utilizzare un binario riportata (INOX o Alluminio), per lo scorrimento facilitato e l'usura con conseguente sostituzione. I profilati di telaio fisso dovranno essere predisposti, dove necessario, per ricevere alette di battuta interna sulla muratura di un minimo di 25 mm. in poi.

I profilati di ante mobili potranno contenere vetrazioni fino a 38 mm. Inoltre le finestre e porte scorrevoli avranno la possibilità di essere realizzate con 1 o più ante compresa la soluzione angolare.

ISOLAMENTO TERMICO

L'inerruzione del Il ponte termico sarà garantito da barrette continue in poliammide da 36 mm. tubolari per le ante mobili e da 34 mm. per i telai. Dovrà garantire un valore di trasmittanza termica per l'infisso $U_w = \dots\dots W/m^2K$. L'assemblaggio dei profilati in alluminio a taglio termico dovrà garantire i valori di scorrimento (T) tra profilati in alluminio e barrette in POLIAMMIDE previsti dalla direttiva tecnica Europea (UEAtc).

DRENAGGI E VENTILAZIONE

I profilati esterni delle ante mobili dovranno prevedere una gola ribassata per la raccolta delle acque di infiltrazione e di condensa onde poter permettere il libero deflusso delle stesse attraverso apposite asole di scarico. Le barrette in poliammide dovranno avere una conformazione geometrica atta ad evitare eventuale ristagno di acque di infiltrazione e di condensa ed essere perfettamente complanari con le pareti trasversali dei profilati di alluminio.

ACCESSORI DI ASSEMBLAGGIO

Le giunzioni tra profilati orizzontali e verticali saranno perfettamente solidali e ben allineate tra di loro, sia nella parte esterna che interna dei profilati ed unite mediante apposite squadrette a bottone o, in alternativa, in alluminio estruso o pressofuso, con metodo a spino-cianfrinatura od a cianfrinatura totale. Le sezioni dei profilati orizzontali e verticali dovranno essere opportunamente sigillate prima di essere unite con le squadrette. I fermavetri saranno accoppiati a scatto e posizionati nei canali dei profilati in alluminio.

GUARNIZIONI

Tutte le guarnizioni: cingivetro, di tenuta, di battuta... dovranno essere in elastomero (EPDM). In particolare la guarnizione di tenuta centrale dovrà assicurare il serraggio delle due ante su tutta la verticale di incontro. Entrambe le soluzioni (Anta 45° o 90°) assicurano la continuità degli angoli lato telaio grazie ad angolari vulcanizzati.

PRESTAZIONI

Le soluzioni proposte hanno prestazioni di permeabilità all'aria, tenuta all'acqua e resistenza ai carichi del vento conformi alle norme: (UNI-EN 12207 - 12208 - 12210 e UNI-EN 1026 - 1027 - 12211)

PROFILE COMPOSITION

The window profiles are made of ENAW 6060 aluminum alloy (EN 573-3 and EN 755-2) with physical state of supply UNI EN 515. The fixed frames and sliding doors must be made with three-chamber thermal break profiles (tubular internal and external profile, connected to each other with glass fibre reinforced polyamide PA6.6 bars).

DOORS AND WINDOWS

The registered sliding doors and windows sash have a fixed frame profile with a depth of 85 mm. (alternatively mm. 60.3 for single-leaf and mm. 145 for 3-leaf) and a mobile leaf profile with depth minimum 46 mm. The registered lower fixed frame profiles have the possibility of using a stainless steel or aluminium rail, brought back, for easier sliding and wear with subsequent replacement. The registered fixed frame profiles must be prepared, where necessary, to have internal rebate fins from 25 mm thick masonry. The profiles of mobile doors can contain glazing up to 38 mm. Furthermore, the windows and sliding doors will have the possibility of being made with 1 or more doors including the corner solution

THERMAL BREAK

The interruption of the thermal bridge will be obtained by continuous 36 mm polyamide bars. for frames, and 34 mm. tubular for the mobile leaves, and must guarantee a thermal transmittance value for the frame $U_w = \dots\dots W/m^2K$. The assembly of aluminum profiles with thermal break must guarantee the sliding values (T) between aluminum profiles and POLYAMIDE bars envisaged by the European technical directive (UEAtc).

DRAINAGE AND VENTILATION

The junctions between horizontal and vertical profiles must be perfectly integral and well aligned with each other, both in the external and internal part of the profiles and joined by means of special button brackets or, alternatively, in extruded or die-cast aluminum, with the pin-crimping method or with total crimping. The sections of the horizontal and vertical profiles must be properly sealed before being joined with the brackets. The glazing beads will be snap coupled and positioned in the channels of the aluminum profiles.

ASSEMBLY ACCESSORIES

The joints between the horizontal and vertical profiles must be perfectly united and correctly aligned with each other, both externally and internally and joined by means of special slot corner joints or, alternatively, in extruded or die-cast aluminum, with a dowel-crimping or full crimping method. The sections of the horizontal and vertical profiles must be properly sealed before being joined with the corner joints. The glazing beads will be snap-coupled and positioned in the channels of the aluminum profiles.

WINDOW GASKETS

All gaskets: girdle, seal, rebate... shall be made of elastomer (EPDM). In particular, the central sealing gasket shall ensure the tightening of the two sashes on the entire vertical meeting. Both solutions (45° or 90° sash) shall ensure the continuity of the frame side corners thanks to vulcanized corner pieces.

PRESTAZIONI

I serramenti dovranno avere prestazioni di permeabilità all'aria, tenuta all'acqua e resistenza ai carichi del vento conformemente alle norme: (UNI-EN 12207 - 12208 - 12210 e UNI-EN 1026 - 1027 - 12211)

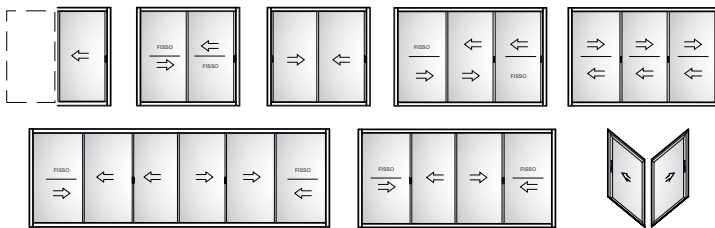
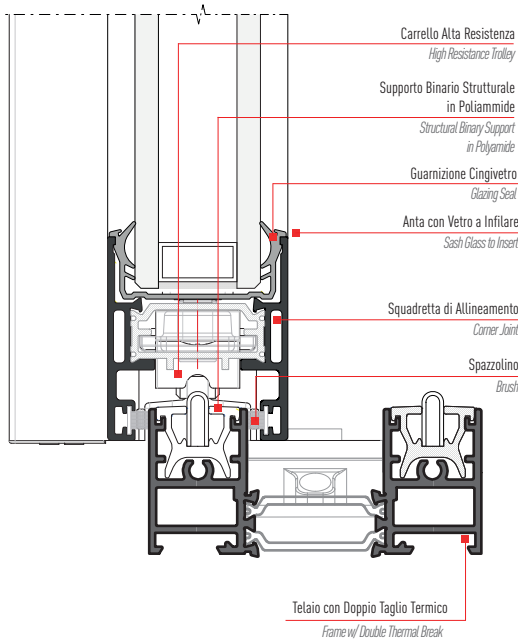

CARATTERISTICHE FISICHE

Profilati estrusi lega:
• ENAW 6060 (EN 573 - 3)
Stato di fornitura:
• T5 (EN 752 - 2)
Tolleranze dim. e spessori:
• EN 755 - 9
Tipo di tenuta aria/acqua:
• Con spazzolino / guarnizione speciale per scorrimento.
Inserimento del vetro :
• Ad infilare e Fermavetro
H utile alloggiamento vetro:
• mm. 17,5. Possibilità di inserimento volumi di vetro o pannelli con spessori variabili fino a mm. 38.
Impiego:
• Profilati per finestre e porte scorrevoli ad alto valore termico che consentono la costruzione di infissi ad una, due o più ante e soluzione angolare.
Gli accessori del sistema SX 85 permettono la realizzazione di ante con peso di 240 kg.

PHYSICAL CHARACTERISTICS

Alloy extruded profiles:
• ENAW 6060 (EN 573 - 3)
Delivery State:
• T5 (EN 752 - 2)
Size and thickness tolerances:
• EN 755 - 9
Type of air/water seal:
• With brush / special sliding seal.
Glass insertion :
• To insert and Glass Holder
H useful glass housing:
• mm. 17.5. Possibility of inserting glass volumes or panels with variable thicknesses up to mm. 38.
Use:
• Profiles for windows and sliding doors with high thermal value that allow the construction of fixtures with one, two or more wings and angular solution.
The accessories of the SX 85 system allow the creation of doors with a weight of 240 kg.

CARATTERISTICHE FISICHE | PHYSICAL CHARACTERISTICS

- ◆ Telaio Fisso | Fixed Frame: _____ 60.3/120 - 145 x 37 mm.
- ◆ Telaio Mobile | Window Frame: _____ 46 x 34/52 mm.
- ◆ Barrette Isolanti | Insulating Rods: _____ 36 - 43 mm.
- ◆ Alloggiamento Accessori | Accessories Housing: _____ ad inserimento [insertion]
- ◆ Giunzione Angolare | Corner Joint: _squadrette [Corner Joints]

PRESTAZIONI CERTIFICATE | CERTIFIED PERFORMANCES

AAV

- ◆ Permeabilità all'aria | Air Permeability: _____ Classe 4
- ◆ Tenuta all'acqua | Watertightness: _____ Classe 9A
- ◆ Carico di vento | Wind load resistance: _____ Classe C5
- ◆ Isolamento acustico | Sound Insulation: _____ 42 dB
- ◆ Resistenza all'effrazione | Breakage resistance: _____ -

Risultati dei test / CE product pass conforme ad:

Tests Results / CE product pass Compliant with:
UNI EN 14351-1:2006+A1:2010

TRASMITTANZA TRANSMITTANCE

$U_w = 1,38 \text{ W/(m}^2\text{K)}$

SERRAMENTO CAMPIONE | SAMPLE FRAME

- ◆ Vetro Certificato | Certified Glass:
Double Glazing $U_g = 1.0 \text{ W/(m}^2\text{K)}$
- ◆ Canalina | Duct: $\psi = 0.036 \text{ W/(m}^2\text{K)}$
- ◆ Finestra normalizzata | Normalized Window:
H = 2500 mm. ed L = 2180 mm.

$U_w = 1.11 \text{ W/(m}^2\text{K)}$

SERRAMENTO CAMPIONE | SAMPLE FRAME

- ◆ Vetro Certificato | Certified Glass:
Triple Glazing $U_g = 0.7 \text{ W/(m}^2\text{K)}$
- ◆ Canalina | Duct: $\psi = 0.031 \text{ W/(m}^2\text{K)}$
- ◆ Finestra normalizzata | Normalized Window:
H = 2500 mm. ed L = 2180 mm.
- Dimensioni massime ammesse per il calcolo U_w su serramento campione fino a 2.3 m² (secondo norma UNI EN 14351-1:2006+A1:2010)
- Maximum allowable dimensions for calculation of the U_w on sample window frame up to 2.3 m² (according to UNI EN 14351-1:2006+A1:2010)

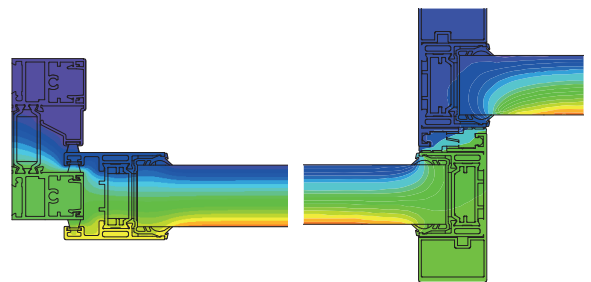

- Analisi termica con FLIXO vers.8 e WinIso2D Professional 7.8
- Thermiccon FLIXO vers.8 e WinIso2D Professional 7.8



Tenuta all'Acqua
Water-tightness



Capacità di un inso di impedire infiltrazioni quando è investito da un flusso d'acqua ed è presente una differente pressione tra interno ed esterno.
Capacity of a window to prevent infiltrations when impacted by a gush of water and there is a different internal and external pressure.

Press.	0Pa5	0Pa	100Pa	150Pa	200Pa	250Pa	300Pa	450Pa	600Pa	750Pa	900Pa	1050Pa	1200Pa	1350Pa	1500Pa	Pressure
Velocità	03	24	55	56	47	27	89	6	111	126	138	149	159	169	178	Speed
Classe	-1	A2	A3	A4	A5	A6	A7	A8	9A	E750	E900	E1050	E1200	E1350	E1500	Class

L'infisso TWIN, con una pressione del vento pari ad una velocità di 178 Km/h (1500Pa) non ha avuto infiltrazioni
The frame TWIN with a wind pressure equal to a speed of 178 Km/h (1500Pa), had no infiltrations

Classe | Class
9A
EN 1027 - EN 12208

Tenuta all'Aria
Air Permeability



Caratteristica di un inso chiuso di lasciare trarre aria quando è presente una differenza di pressione tra l'interno e l'esterno; minori saranno i volumi dispersi, maggiore sarà la qualità del serramento.
Characteristic of a closed window to let air filter through when there is a different internal and external pressure; the lower the dispersed volumes, the higher the quality of the frame.

Press.	150Pa	300Pa	450Pa	600Pa	Pressure
Classe	1	2	3	4	Class

L'infisso TWIN ha superato la prova con Pressione Vento = 111 k/h (600Pa)
The frame TWIN has passed the test with a Wind Pressure = 111 Km/h (600Pa)

Classe | Class
4
EN 1026 - EN 12207

Resist. al Vento
Wind Resistance

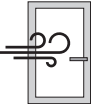

Capacità di un inso sottoposto a forti pressioni e/o depressioni, come quelle causate dal vento, di mantenere una deformazione ammissibile, di conservare le proprietà iniziali a salvaguardia della sicurezza degli utenti.
Capacity of a window subject to high positive and/or negative pressures, like that caused by the wind, to maintain an admissible deformation, to conserve its initial properties and to safeguard users against breakage.

Press.	400Pa	800Pa	1200Pa	1600Pa	2000Pa	>2000Pa	Pressure
Flessione	A (≤ 1/150)	B (≤ 1/200)	C (≤ 1/300)				Flexure
Classe	12	34	5E	xxx			Class

* Serramento a 2 ante, dimensione L = mm.3000 ed H = mm.2100 - Certificato n° RP n° 1994-CPR-RP1850 (Altre Certificazioni Disponibili)
Double Casement window, dimension L = mm.3000 ed H = mm.2100 - Test certificate no. RP no. 1994-CPR-RP1850 (Other certifications available).

Classe | Class
C5
EN 12211-EN 12210

Fonopisolamento
Sound Insulation



Perdita di isolamento acustico rispetto al vetro DR_w (dB) a partire dalla classe di permeabilità all'aria dell'infisso (UNI EN 12207)
Capacity of a window to resist violent intrusion following the application of a physical force or with the aid of tools.

Classe	1	2	3	4	Class	DR _w ≤ 38 dB	Amnesso l'utilizzo di questo metodo tabellare
Perdita	8dB	6dB	4dB	2dB	Loss	DR _w > 39 dB	Necessario realizzare un campione al vero e sottoporre a prove di Laboratorio.

An actual sample must be made and tested in the laboratory.

Abbattimento Acustico
Noise Reduction
42dB
EN ISO140-3 | 717-1

Trasmissione
Transmittance

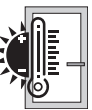

Flusso di calore che passa attraverso il serramento per m2 di superficie e per ogni grado di differenza di temperatura tra interno ed esterno.
Flow of heat that passes through the window per m2 of surface and for every degree of difference in temperature between outdoors and indoors.

U_w	1.38 W/m²K
Finestra a 2 ante normalizzata (2500 mm. x 2180 mm; vetro doppio U _g =1.0 W/m²K certificato con canalina psi=0.036 W/m²K) Normalised 2 Sashes window (2500 mm x 2180 mm; double glazing U _g =1.0 W/m²K certified with duct psi=0.036 W/m²K)	
U_w	1.11 W/m²K
Finestra a 2 ante normalizzata (2500 mm. x 2180 mm; vetro triplo U _g = 0.7 W/m²K certificato con canalina psi=0.031 W/m²K) Normalised 2 Sashes window (2500 mm x 2180 mm; triple glazing U _g = 0.7 W/m²K certified with duct psi=0.031 W/m²K)	

Antieffrazione
Breakege Resistance



Capacità di un infisso di resistere ad un'intrusione violenta a seguito di una applicazione di una forza fisica e con l'aiuto di attrezzi Finestra a 2 ante (1230 mm. x 1480 mm) - CERTIFICATO 0476/RP/2022
Capacity of a window to resist violent intrusion following the application of a physical force or with the aid of tools. 2 sashes window (1230 mm x 1480 mm) - 0476/RP/2022 CERTIFIED door

Classe	RC1	RC2	RC3
Intrusione	Forza Fisica (Calci Pugni, Spallate)	Semplice Attrezzatura (Cunei, Cacciaviti)	R2 + Piede di Porco
Intrusion	Physical strength (kicks, pushing, pushing with shoulder)	Simple Tools (Wedges, Screwdrivers)	R2 + Crowbar

L'infisso TWIN, resiste in modo efficace ai tentativi di intrusione interna.
The TWIN window effectively resists attempted breakins

Resistenza Effrazione
Breakege Resistance
RC1

**LA MARCATURA CE DELLE FINESTRE E PORTE PEDONALI**
[Senza caratteristiche di resistenza al fuoco e/o di tenuta al fumo]

Il marchio CE, apposto sui prodotti da costruzione, attesta la loro conformità ai requisiti essenziali definiti dalla direttiva 89/106/CE "Prodotti da costruzione", emanata dal Consiglio della Comunità Europea il 21/12/1988 ed attuata, in Italia, dal D.P.R. n. 246 del 21/04/1993. La marcatura CE di uno specifico prodotto da costruzione diviene obbligatoria, al fine di immettere il prodotto in un mercato della Comunità Europea, allorché sia stata emessa dal CEN, su mandato della Comunità Europea, una "specificazione tecnica" (norma o benessere tecnico) che regolamenti la sua applicazione.

La responsabilità per la verifica dei requisiti del prodotto e per l'apposizione della marcatura CE spetta al suo fabbricante.

Al fine di garantire i requisiti richiesti dalle relative norme, il fabbricante è tenuto a:

- ◆ **Predisporre un piano di controllo della produzione (FPC). E' un sistema di procedure e controlli da eseguire durante le fasi di produzione**
- ◆ **Effettuare delle "prove iniziali di tipo" (ITT) sul prodotto al fine di determinare le prestazioni. Le modalità di prova dei requisiti del prodotto sono definite dalle norme richiamate dalla specifica norma prodotto".**

Alcune prove possono essere eseguite dal produttore stesso, secondo le disposizioni delle relative norme armonizzate, mentre altri requisiti sono di competenza di laboratori in possesso di una notifica attribuita loro dallo stato membro di appartenenza (organismi notificati).

IL FABBRICANTE PUO' PROCEDERE IN PIU' MODI

- ◆ **Eseguire autonomamente i test sui propri prodotti presso un istituto Notificato, diventando quindi titolare degli ITT**
- ◆ **Far riferimento ai risultati di prove effettuate dal detentore del sistema di serramento, purché quest'ultimo abbia espresso il proprio consenso per mezzo di un contratto di licenza d'uso stipulato tra le parti.**

Da Febbraio 2010 è obbligatoria la marcatura CE per finestre e porte pedonabili senza caratteristiche di resistenza al fuoco e tenuta al fumo.

L'appendice ZA della norma UNI EN 14351-1 specifica le caratteristiche essenziali per finestre e porte e attribuisce le competenze delle prove iniziali di tipo.

Il requisito relativo ad una determinata caratteristica non è applicabile in quegli Stati Membri nei quali non sussistono requisiti di regolamentazione per tale caratteristica per l'impiego previsto del prodotto. In questo caso, i fabbricanti che immettono i loro prodotti sul mercato di questi Stati membri non sono obbligati a determinare né a dichiarare le prestazioni dei loro prodotti in relazione a questa caratteristica e può essere utilizzata l'opzione "Nessuna Prestazione Determinata" (NPD) nelle informazioni che accompagnano la marcatura CE (vedere punto ZA.3). Tuttavia, l'opzione NPD non può essere utilizzata nel caso in cui la caratteristica sia soggetta a un livello soglia. (Citazione integrale tratta dalla norma UNI EN 14351-1 - appendice ZA)

Per finestre e porte senza funzione di compartimentazione del fuoco o fumo e non poste nelle vie di fuga (sistema di attestazione della conformità 3):

CE MARKING OF PEDESTRIAN WINDOWS AND DOORS
[Without fire resistance and/or smoke resistance characteristics]

The CE marking, affixed to products, certifies their compliance with the essential requirements of Directive 89/106/EC "Construction products", issued by the Council of the European Community on 21/12/1988 and implemented, in Italy, by Presidential Decree no. 246 of 21/04/1993. The CE marking of a specific product is mandatory when the product is to be placed on a European Community market, whenever a "technical specification" (standard or technical approval) that regulates its application has been issued by CEN, under mandate of the European Community.

The manufacturer is responsible for verifying product requirements and affixing the CE marking. To ensure fulfilment of the requirements of the relevant standards, the manufacturer must:

- ◆ **Draw up a production control plan (PCP). This system of procedures and controls are performed during the production stages.**
- ◆ **Carry out "initial type tests" (ITT) on the product in order to determine performance. The test methods of the product requirements are defined by the standards referred to in the specific product standard".**

Some tests can be carried out by the manufacturer, in accordance with the provisions of the relevant harmonised standards, while others are the responsibility of laboratories awarded notified body status by their Member State (notified bodies).

THE MANUFACTURER MAY PROCEED IN SEVERAL WAYS:

- ◆ **Carry out the tests on its products independently at a Notified Body, thus becoming the holder of the ITTs**
- ◆ **Refer to the results of tests carried out by the holder of the window and door system, provided that the latter has given his consent by means of a user licence agreement signed by the parties.**

From February 2010, CE marking is mandatory for pedestrian windows and doors without fire resistance and smoke resistance characteristics.

Appendix ZA of standard UNI EN 14351-1 specifies the essential characteristics for windows and doors and attributes responsibilities for the initial type tests.

The requirement for a given characteristic does not apply in the Member States where there are no regulatory requirements for that characteristic for the intended use of the product. In this case, manufacturers who place their products on the market of these Member States shall not be obliged to determine or to declare the performance of their products for same characteristic and the "No Performance Determined" (NPD) option may be used in the information accompanying the CE marking (see point ZA.3). However, the NPD option cannot be used when the characteristic is subject to a threshold level. (Full quote from UNI EN 14351-1 - Appendix ZA)



For windows and doors without a fire or smoke compartmentalization function and not located in run off areas (conformity attestation system 3):

CARATTERISTICHE FONDAMENTALI FUNDAMENTAL CHARACTERISTICS	Espressioni di Prestazione Expressions of Performance	Competenze Prove Iniziali Tipo Initial Type Test Responsibilities		
		ON= Organismo Notificato; PR= Produttore ON=Notified Body; PR= Manufacturer		
		Finestre Windows	Porte Doors	Lucernari Hopper Windows
Comportamento al FUOCO Dall'Esterno External Fire Behaviour				ON
Resistenza al FUOCO Fire Reaction	Euroclassi Euroclasses			ON
Tenuta all'ACQUA Watertightness	Classi Tecniche Technical Classes	ON	ON	ON
Sostanze Pericolose Hazardous Substances		ON	ON	
Resistenza al Carico del VENTO Wind Load Resistance	Classi Tecniche Technical Classes	ON	ON	PR
Resistenza al Carico della NEVE e Carico Premanente Snow Load and Permanent Load	Classi Tecniche Technical Classes			PR
Resistenza all'URTO Shock Resistance	KN/m² KN/sqm		PR	ON
Capacità Portante dei Dispositivi di Sicurezza Load-bearing Capacity of Safety devices	Soglia Threshold	ON	ON	ON
Altezza Height	mm.		PR	
Forze di azionamento (solo dispositivi automatici) Operating forces (automatic devices only)	Classi Tecniche Technical Classes		ON	
Prestazione acustica Acoustic Performance	dB	ON	ON	ON
Trasmittanza termica Heat Transmittance	W/m²K	ON	ON	ON
Proprietà radioattive Radioactive properties				PR
Permeabilità all'ARIA AIR Permeability	Classi Tecniche Technical Classes	ON	ON	PR

La valutazione delle caratteristiche da dichiarare è funzione della destinazione d'uso del prodotto e della legislazione vigente nello Stato Membro, ove esso è immesso.

The characteristics to be declared depend on the intended use of the product and the legislation in force in the Member State where it is sold.



TEST INIZIALI di TIPO (ITT)

La serie riportata nel presente catalogo è stata sottoposta a test iniziali di tipo (ITT) relativamente ai requisiti previsti dalla norma prodotto UNI EN 14351-1. I risultati dei test iniziali di tipo sono estendibili a serramenti di differente tipologia e con differenti dimensioni e componenti, secondo le indicazioni fornite dalla norma EN 14351-1 in Appendice A (interdipendenza fra le caratteristiche e i componenti), Appendice E (determinazione delle caratteristiche) ed Appendice F (selezione facoltativa di provini rappresentativi per le finestre)

Il costruttore di serramenti ha la responsabilità di verificare la rispondenza del serramento prodotto rispetto al campione sottoposto a prova. Il consorzio TWIN Systems mette a disposizione dei propri clienti i risultati dei test effettuati, a seguito della stipulazione di un contratto d'uso gratuito degli stessi.

Dichiarazione di Conformità

Il fabbricante del serramento è tenuto a consegnare al committente una dichiarazione di conformità la quale, in accordo alla norma UNI EN 14351-1, deve includere :

- ◆ Nome ed indirizzo del fabbricante o del suo rappresentante autorizzato con sede nella EEA;
- ◆ Descrizione del prodotto (tipo, identificazione, impiego, ecc.) e una copia delle informazioni che accompagnano la marcatura CE;
- ◆ Disposizioni alle quali il prodotto è conforme (appendice AZ della norma prodotto UNI EN 14351-1);
- ◆ Condizioni particolari applicabili all'impiego del prodotto (per esempio disposizioni per l'impiego in determinante condizioni, ecc.);
- ◆ Nome e indirizzo del/i laboratorio/i approvato/i.
- ◆ Nome e qualifica della persona incaricata di firmare la dichiarazione per conto del fabbricante o del suo rappresentante autorizzato.

La dichiarazione e il certificato devono essere presentati nella lingua o nelle lingue ufficiali dello Stato Membro in cui il prodotto deve essere utilizzato.

Etichettatura e Marcatura

Il fabbricante deve fornire informazioni sufficienti ad assicurare la rintracciabilità del suo prodotto fornendo il collegamento fra il prodotto, il fabbricante e la produzione. Queste informazioni devono essere contenute su un'etichetta o specificate in documenti di accompagnamento nelle specifiche tecniche pubblicate dal fabbricante. Le informazioni seguenti devono accompagnare il simbolo di marcatura CE:

Il simbolo della marcatura CE e le informazioni di accompagnamento devono essere apposti in modo visibile, leggibile e indelebile in una o più delle posizioni seguenti (gerarchia di preferenza del fabbricante):

Qualsiasi parte idonea del prodotto stesso, purché sia assicurata la visibilità quando si aprono le ante; Su un'etichetta attaccata; Sul suo imballaggio; Sul documento commerciale di accompagnamento.

INITIAL TYPE TESTS (ITT)

The series in this catalogue has been subjected to initial type tests (ITT) for the requirements of product standard UNI EN 14351-1.

The results of the initial type tests can be extended to doors and windows of different types and of different sizes and compositions, according to the indications provided for by EN 14351-1 in Appendix A (interdependence between the characteristics and compositions), Appendix E (determination of characteristics) and Appendix F (optional selection of representative samples for the windows).

The door and window manufacturer is responsible for verifying compliance of the window with the sample under test. The TWIN Systems consortium makes the results of the test performed available to its customer, after the free usage agreement has been signed.

Declaration of Conformity

The window and door manufacturer must provide the customer with a declaration of conformity which, in accordance with UNI EN 14351-1, must include:

- ◆ *Name and address of the manufacturer or its authorised representative established in the EEA;*
- ◆ *Description of the product (type, identification, use, etc.) and a copy of the information accompanying the CE marking;*
- ◆ *Provisions with which the product complies (Appendix AZ of product standard UNI EN 14351-1);*
- ◆ *Special conditions applicable to the use of the product (e.g. provisions for use under certain conditions, etc.);*
- ◆ *Name and address of the approved laboratory(ies).*
- ◆ *Name and capacity of the person empowered to sign the declaration on behalf of the manufacturer or his authorised representative.*

The declaration and certificate must be done in the official language or languages of the Member State where the product is to be used.

Labelling and Marking

The manufacturer must provide sufficient information to ensure the traceability of the product providing the link between the product, the manufacturer and the production. This information must be contained on a label or specified in accompanying documents in the technical specifications published by the manufacturer. The following information must accompany the CE marking symbol:

- ◆ *Manufacturer's name and registered address or identification mark;*
- ◆ *Last two digits of the year in which the CE marking was applied;*
- ◆ *Reference to the product standard (EN 14351-1);*
- ◆ *Description of the product: generic name, material, size, etc. and intended use;*
- ◆ *Information about the essential characteristics that must be declared;*
- ◆ *Declared values or levels and/or classes;*
- ◆ *NPD - "No Performance Determined" for characteristics when relevant.*



DOCUMENTAZIONE TECNICA DI ACCOMPAGNAMENTO

Il fabbricante deve fornire informazioni su quanto segue:

- Immagazzinaggio e movimentazione, se il fabbricante non è responsabile dell'installazione del prodotto;
- Requisiti e tecniche d'installazione (sul posto), se il fabbricante non è responsabile dell'installazione del prodotto (Guida UNCSAAL)
- Manutenzione e pulizia (Manuale Consorzio TWIN SYSTEMS)
- Istruzioni d'uso finali incluse le istruzioni per la sostituzione di componenti
- Istruzioni per l'uso in condizioni di sicurezza.

In Italia i requisiti obbligatori per la Marcatura CE sono:

- Permeabilità dell'aria
- Trasmittanza termica
- Proprietà radiative (Fattore solare g, Trasmissione luminosa (TV))

In Spagna e in Portogallo i requisiti obbligatori per la Marcatura CE sono:

- Permeabilità all'aria
- Tenuta all'acqua
- Resistenza al vento
- Trasmittanza termica
- Isolamento acustico

The CE marking and accompanying information must be affixed in a visible, legible and indelible way in one or more of the following positions (manufacturer's hierarchy of preference):

Any suitable part of the product itself, provided that visibility is ensured when opening the doors; On an attached label; On its packaging; On the accompanying commercial document.

ACCOMPANYING TECHNICAL DOCUMENTATION

The manufacturer will provide information about:

- Storage and handling, if the manufacturer is not responsible for the installation of the product
- Requirements and installation methods (on site), if the manufacturer is not responsible for the installation of the product (UNCSAAL Guide)
- Maintenance and cleaning (TWIN SYSTEMS Consortium Manual)
- Final instructions for use including instructions for replacing components; Instructions for safe use.

In Italy, the mandatory requirements for CE marking are:

- Air permeability
- Heat Transmittance
- Radiative properties (Solar factor g, Light transmission (TV)).

In Spain and Portugal the mandatory requirements for CE marking are :

- Air permeability
- Watertightnes
- Wind resistance
- Heat Transmittance
- Sound insulation



TRASMITTANZA TERMICA DEI SERRAMENTI

HEAT TRANSMISSION OF WINDOWS

E' necessario sapere che le prescrizioni dettate dal decreto ministeriale cambiano in funzione della tipologia di intervento edilizio (nuova costruzione, ristrutturazione importante di primo oppure secondo livello, riqualificazione energetica) e si applicano ad edifici sia pubblici sia privati.

Per edifici di nuova costruzione si intendono quei fabbricati il cui titolo abilitativo sia stato richiesto dopo l'entrata in vigore del decreto.

Sono assimilati agli edifici di nuova costruzione gli edifici sottoposti a demolizione e ricostruzione, qualunque sia il titolo abilitativo necessario, e gli ampliamenti di edifici esistenti la cui nuova porzione abbia un volume lordo climatizzato superiore al 15% di quello esistente o comunque superiore a 500 m³.

Per interventi di ristrutturazione importante di primo livello si intendono quelli che interessano l'involucro edilizio con un'incidenza superiore al 50 per cento della superficie disperdente lorda complessiva dell'edificio, comprendendo anche la ristrutturazione dell'impianto termico per il servizio di climatizzazione invernale e/o estiva asservito all'intero edificio.

Per interventi di ristrutturazione importante di secondo livello si intendono quelli che interessano l'involucro edilizio con un'incidenza superiore al 25 per cento della superficie disperdente lorda complessiva dell'edificio e possono interessare l'impianto termico per il servizio di climatizzazione invernale e/o estiva.

Negli interventi di riqualificazione energetica rientrano gli interventi non riconducibili agli interventi succitati e che hanno un impatto sulla prestazione energetica dell'edificio. Rientrano quindi anche:

- Le ristrutturazioni che interessano l'involucro edilizio con un'incidenza inferiore o uguale al 25% della superficie disperdente lorda complessiva dell'edificio e/o consistono nella nuova installazione, nella ristrutturazione di un impianto termico asservito all'edificio o di altri interventi parziali, ivi compresa la sostituzione del generatore;
- Gli ampliamenti di edifici esistenti la cui nuova porzione abbia un volume lordo climatizzato inferiore o uguale al 15% di quello esistente o comunque inferiore a 500 m³.

Per gli edifici di nuova costruzione e per quelli sottoposti a ristrutturazioni di primo livello, non sono previsti specifici limiti di trasmittanza termica da rispettare per le chiusure trasparenti. Sussiste l'obbligo di rispettare limiti per quanto concerne altri parametri tecnici che connotano gli impianti, l'involucro edilizio e l'edificio nel loro complesso (per esempio coefficiente medio globale di scambio termico per trasmissione per unità di superficie disperdente HT' - area solare equivalente estiva per unità di superficie utile Asol,est/Asup - indice di prestazione termica utile per riscaldamento EPH,nd - indice di prestazione termica utile per il raffrescamento EPC,nd - indice di prestazione energetica globale dell'edificio EPgl,tot, ecc.) contenuti nell'Allegato A del decreto.

Note that the requirements as of the ministerial decree depend on the type of construction (new construction, major first or second level renovation, energy upgrading) and apply to both public and private buildings.

New buildings are those whose building permit has been requested following the promulgation of the decree.

Buildings subject to demolition and reconstruction, irrespective of the type of building permit, and extensions to existing buildings whose new portion has a gross air-conditioned volume of more than 15% of the existing one or in any case more than 500 m³ are considered new buildings.

Major first level renovations are those affecting the building shell with an impact of more than 50% of the building's total gross dispersant surface, also including the renovation of the heating system for the winter and/or summer air conditioning service of the entire building.

For major second-level renovation interventions, those that concern the building shell with an impact of more than 25 percent of the building's total gross dispersant surface and can regard the heating plant system for the winter and/or summer air conditioning service.

Energy upgrading works include activities that are not attributable to the aforementioned activities and that have an impact on the building's energy performance. The following are therefore also included:

- Renovations that affect the building shell with an impact of less than or equal to 25% of the building's total gross dispersant surface and/or the new installation or upgrading of the building's heating plant or other partial works, including the replacement of the generator;
- Extensions of existing buildings whose new portion has a gross air-conditioned volume of less than or equal to 15% of the existing one or in any case less than 500 m³.

For new buildings and buildings undergoing first level renovations, there are no specific heat transmission limits to be respected for transparent doors. There is an obligation to respect the limits of other technical parameters that characterise the plants, shell and building as a whole (for example, average overall heat exchange coefficient for transmission by dispersant surface unit HT' - equivalent summer solar area per unit of surface area Asol,est/Asup - useful heat performance index for heating EPH,nd - heat performance index for cooling EPC,nd - overall energy performance index of the building EPgl,tot, etc.) contained in Annex A of the decree



I limiti dell'Allegato A sul coefficiente medio globale di scambio termico per trasmissione per unità di superficie disperdente HT' sono da rispettare anche per gli interventi di ristrutturazione importante di secondo livello.

Nell'ambito degli interventi di ristrutturazione importante di secondo livello e degli interventi di riqualificazione energetica sono invece da rispettare i limiti riportati nell'Appendice B del decreto relativamente:

- Alla trasmittanza termica U_w dei serramenti (trasparenti, opachi) e dei cassonetti posti a delimitazione di ambienti climatizzati verso l'esterno oppure verso ambienti non climatizzati (cfr. tabella 1);
- Al fattore di trasmissione solare totale g_{gl+sh} dei serramenti vetrati in combinazione con schermature solari mobili posizionati sui fronti dell'edificio SUD, EST, OVEST, SUD-EST, SUD-OVEST (cfr. tabella 2).

The limits of Annex A on the overall average coefficient of heat exchange through transmission by unit of dispersant surface HT' must also be respected for major second-level renovations.

In the case of major second level renovations and energy upgrading works, the limits set out in Appendix B of the decree must be respected for:

- Heat transmission U_w of the windows (transparent, opaque) and shutter boxes positioned to delimit air-conditioned environments towards the outside or towards non-conditioned environments (see table 1);
- The total solar transmission factor g_{gl+sh} glazed windows in combination with mobile solar shields positioned on the SOUTH, EAST, WEST, SOUTH-EAST, SOUTH-WEST building façades (see table 2).

Tabella/Table 1

Valori limite della trasmittanza U_w dei serramenti (trasparenti, opachi) e dei cassonetti posti a delimitazione di ambienti climatizzati verso l'esterno oppure verso ambienti non climatizzati.

ZONA CLIMATICA	U_w [W/m ² K]	
	2021	ECOBONUS
Zona A	3.00	2.60
Zona B	3.00	2.60
Zona C	2.00	1.75
Zona D	1.80	1.67
Zona E	1.40	1.30
Zona F	1.00	1.00

Tabella/Table 2

Valori limite del fattore di trasmissione solare totale g_{gl+sh} chiusure trasparenti in presenza di schermature solari mobili installate su fronti dell'edificio SUD, EST, OVEST, SUD-EST, SUD-OVEST

ZONA CLIMATICA CLIMATIC ZONE	g_{gl+sh}
	2021
Zone TUTTE ALL ZONES	0.35



VALUTAZIONE DELLA PRESTAZIONE TERMICA DEI SERRAMENTI

TRASMITTANZA TERMICA:

La trasmittanza termica rappresenta il parametro più significativo per la valutazione del comportamento termico di un prodotto edilizio: minore è il suo valore migliore è la prestazione termica posseduta dal componente stesso. Il calcolo semplificato della trasmittanza termica del componente finestrato U_w , composta da un singolo serramento e relativo vetro (o pannello) si esegue con la formula:

VALUTAZIONE DELLA PRESTAZIONE TERMICA DEI SERRAMENTI

HEAT TRANSMISSION:

Heat transmission is the most significant factor in the evaluation of the thermal performance of a building product: the lower its value, the higher the thermal performance of the product.

The simplified heat transmission calculation of the product glazing U_w , comprising a single window and related glass (or panel) the formula is:

$$U_w = \frac{A_g U_g + A_f U_f + l_g \emptyset_g}{A_g + A_f}$$

- A_g : Area del vetro in m^2
 - U_g : Trasmittanza termica riferito all'area centrale della vetrata, e non include l'effetto del distanziatore del vetro lungo il bordo della vetrata stessa
 - A_f : Area del telaio
 - U_f : Trasmittanza termica del telaio applicabile in assenza della vetrata
 - l_g : Lunghezza del perimetro del vetro
 - \emptyset_g : Trasmittanza termica lineare concernente la conduzione di calore supplementare che avviene a causa dell'interazione tra telaio, vetri e distanziatore dei vetri in funzione delle proprietà termiche di ognuno di questi componenti e si rileva, secondo quanto precisato nell'allegato E della norma UNI EN ISO 10077-1, preferibilmente con il calcolo numerico eseguito in accordo con la norma ISO 10077-2; quando non sono disponibili i risultati di calcolo dettagliati ci si può riferire ai prospetti E.1 ed E.2 i quali indicano i valori \emptyset_g di default per le tipiche combinazioni di telai, vetri e distanziatori.
-
- A_g : Area of the glass in m^2
 - U_g : Heat transmission of the central area of the window, not including the effect of the glass spacer along the edge of the window
 - A_f : Frame area
 - U_f : Heat transmission of the frame applicable in absence of the glass
 - l_g : Length of the perimeter of the glass
 - \emptyset_g : Linear heat transmission concerning the additional heat conduction that occurs due to the interaction between the frame, glass and spacer of the glass as a function of the thermal properties of each of these components and it is noted, as specified in Annex E of standard UNI EN ISO 10077-1, preferably with the numerical calculation performed in accordance with ISO 10077-2; when the detailed calculation results are not available you can refer to the default \emptyset_g for the typical combinations of frames, glass and spacers.

ESTENDIBILITÀ

L'appendice F della norma di prodotto UNI EN 14351-1 suggerisce le tipologie di serramento rappresentative e le relative estensioni, ma essendo la tabella puramente informativa, sta allo stesso produttore scegliere i campioni.

EXTENSIBILITY

Appendix F of the product standard UNI EN 14351-1 suggests the types of typical windows and their extensions, but since the table is purely informative, it is up to the manufacturer to choose the samples.

TIPO DI FINESTRA WINDOW TYPE	POSSIBILE ESTENSIONE Possible Extension
Anta FISSA Fixed	Finestra Battente/Ribalta Tilt & Turn Window
Porta Finestra ad Anta Singola (Apertura Interna o Esterna) Single door window (internal or external opening)	
Finestra Anta Singola con Ribalta Single Sash Tilt & Turn Window	
Finestra con DUE o più Porte (Apertura Interna o Esterna) Window with two or more doors (internal or external opening)	Stessa Tipologia Same Type
Finestra a UNA o DUE ante orizzontali scorrevoli Window with ONE or TWO horizontal sliding sashes	Stessa Tipologia Same Type
Finestra con DUE Ante Scorrevoli Window with TWO Sliding Sashes	Stessa Tipologia Same Type
Finestra a UNA o DUE ante orizzontali scorrevoli con Ribalta Window with ONE or TWO horizontal sliding sashes with Tilt & Turn	Stessa Tipologia Same Type
Bilico Orizzontale o Verticale Horizontal or vertical pivoting window	Stessa Tipologia Same Type
Finestra a Soffietto Folding Window	Stessa Tipologia Same Type

La norma UNI EN 14351-1 prevede che il calcolo effettuato su di un serramento aventi dimensioni:

1230 (±25%) x 1480 (-25%)
1480 (+25%) x 2180 (±25%)

Le analisi termiche effettuate con le misure sopra descritte, possono essere estese a tutti i serramenti di tutte le dimensioni, purché il vetro utilizzato abbia come valore di U_g uguale o inferiore a $1.9 \text{ w/m}^2\text{K}$, altrimenti la norma dell'appendice F di estensione dei valori calcolati sull'infisso normalizzato ad infissi di diverse dimensioni.

Ovviamente i calcoli devono essere effettuati sulle stesse tipologie di infissi, e s'intende che una modifica del componente modifica la caratteristica in questione. In termini di prestazioni termiche è ovvio che andando a togliere o ad aggiungere elementi (per esempio passare da una finestra ad una anta, da una a due e così via), determina un variazione dei valori finali.

The UNI EN 14351-1 standard sets forth the calculation carried out on a window with dimensions:

1230 (±25%) x 1480 (-25%)
1480 (+25%) x 2180 (±25%)

The thermal analyses carried out with the measurements described above can be extended to doors and windows of all sizes, provided that the glass used has a U_g value equal to or less than $1.9 \text{ w/m}^2\text{K}$, otherwise the standard of the rules of the values calculated on the normalised frame is extended to frames of different sizes.

Obviously, the calculations must be carried out on the same types of frames, and it is understood that any modification to the component changes the characteristic in question. In terms of thermal performance, it is clear that, removing or adding elements (for example, switching from a window with one door to one with two doors, and so on) results in a change in the final values.



POSA QUALITÀ

IL MARCHIO

Il Marchio Posa Qualità Serramenti distinguerà i migliori costruttori italiani di serramenti di tutti i materiali, offrendo ai consumatori italiani uno strumento tangibile per distinguere le migliori aziende con una garanzia assicurativa post vendita sul prodotto installato fino a 10 anni.

In questo modo il costruttore di serramenti potrà qualificare al cliente non solo le prestazioni «astratte» di un serramento, bensì quelle reali, una volta installato, potrà attestare la qualificazione della propria Azienda e potrà garantire nel tempo ciò che ha venduto. Perché un Marchio rigoroso sulla Posa è l'unica forma di garanzia tangibile da offrire al consumatore.

Il progetto Marchi Posa Qualità prevede un piano di formazione che coinvolgerà tutta la filiera industriale del serramento, un Marchio che certificherà la qualità della progettazione della posa attraverso severi test di laboratorio e un Marchio che garantirà e verificherà la sua corretta esecuzione attraverso controlli a campione.

il consorzio TWIN SYSTEMS è certificato PROGETTAZIONE Posa Qualità Serramenti dal 2020. I suoi consorziati organizzano periodicamente corsi professionali per l'acquisizione dei patentini professionali per i posatori.

PROGETTAZIONE



POSA QUALITÀ

THE TRADEMARK

The Posa Qualità Serramenti Trademark identifies the best Italian manufacturers of windows and doors in all materials, offering Italian consumers a tangible way of identifying the best companies with an after-sales warranty on the installed product of up to 10 years.

In this way, the window manufacturer will be able to offer the customer not only a guaranteed "generic" good performance of the window, but real guarantees and, once installed, it will be able to attest the quality of the company and guarantee the products sold over time. Because guaranteed good installation is the only way offering customers peace of mind.

The Posa Qualità Brands project includes a training plan that will involve the entire window supply chain, a Brand that will certify the quality of the installation by means of strict laboratory tests and guarantee correct installation through spot checks.

The TWIN SYSTEMS Consortium has been certified Posa Qualità Serramenti DESIGN since 2020. The consortium members organise periodic training courses for installers with the award of professional licenses.

MANUALE e CATALOGO PRODOTTI TWIN SYSTEMS POSA QUALITÀ



IL MANUALE e CATALOGO PRODOTTI TWIN SYSTEMS per la POSA QUALITÀ è

- Disponibile presso le sedi dei consorziati e dei serramentisti di riferimento
- Liberamente scaricabile sul sito www.twinsystems.it nella sezione CATALOGHI

The TWIN SYSTEMS MANUAL and PRODUCT CATALOGUE for POSA QUALITÀ

- Is available from consortium members and reference window and door manufacturers
- Free download from the website www.twinsystems.it in the CATALOGUES section





Diagramma dei limiti di impiego

Use Limits Diagram

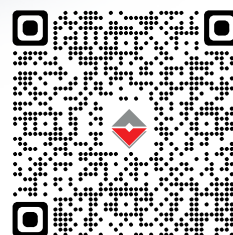
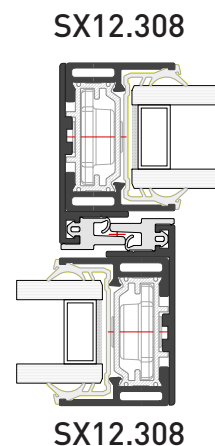
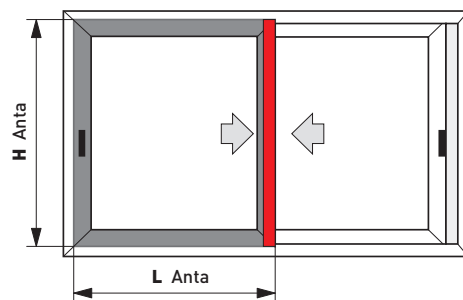
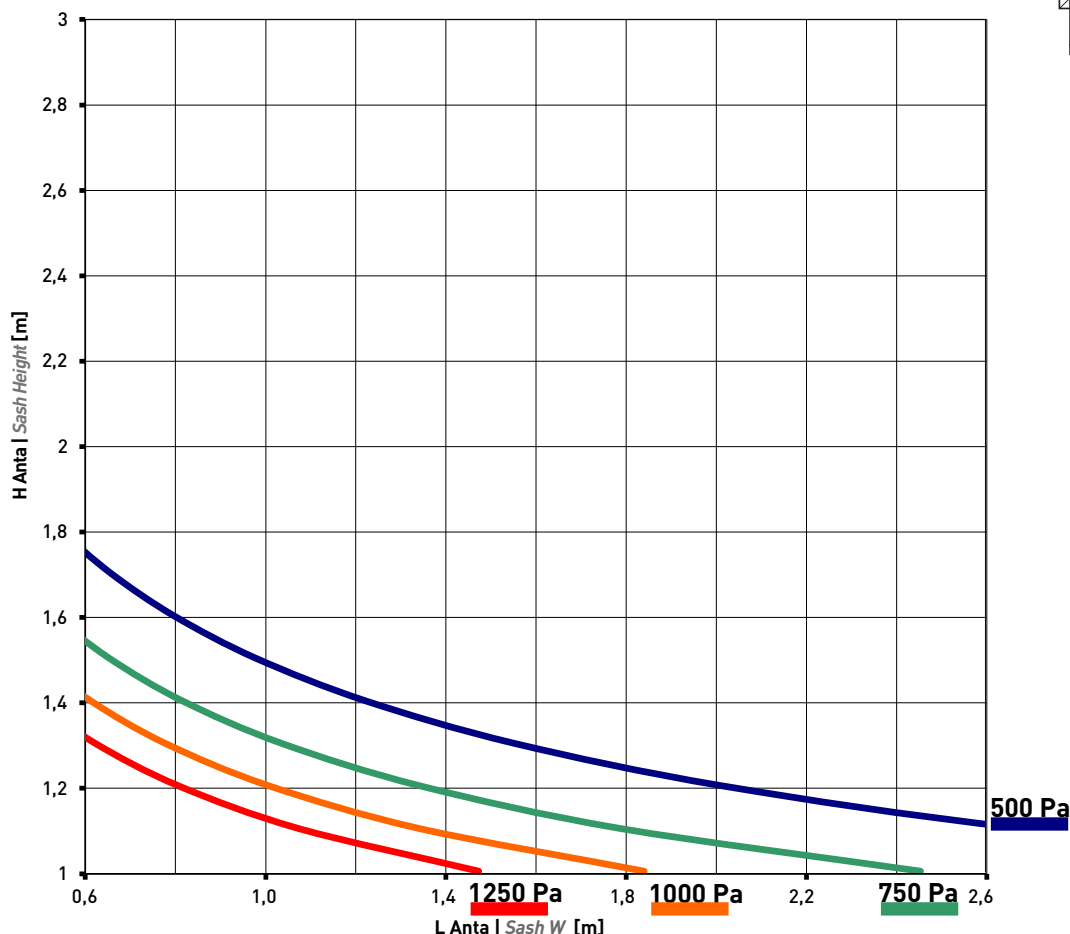

Infisso a 2 ante. Deflessione del nodo centrale

Il dimensionamento risultante dal grafico è solo indicativo. Il progettista o il serramentista, nel determinare le dimensioni massime dei serramenti, dovrà considerare e valutare, oltre le dimensioni ed il momento d'inerzia dei profilati, anche le caratteristiche applicative e meteorologiche quali l'altezza dal suolo, l'esposizione alla pioggia e la velocità dei venti nella zona.

Per questi dati consigliamo di consultare e seguire le "Raccomandazioni UNCSAAL" elaborate sulla base delle norme UNI, UNI-EN e UNI-CNR esistenti in merito.

Verificare che la freccia del profilato sia compatibile con quella del vetro utilizzato.

Le curve rappresentano la larghezza massima dell'anta in funzione della sua altezza e della pressione del vento.

Il serramento è considerato a 2 ante uguali.

Le curve sono calcolate sulla base della deformazione elastica di 1/200 dell'altezza del serramento.

Double sash windows. Deflection of the central node

In determining the maximum dimensions of the doors and windows, in addition to the dimensions and moment of inertia of the profiles, the designer or manufacturer must also consider and evaluate the application and meteorological conditions such as the height from the ground, exposure to rain and the speed of the winds in the area.

For these data, we recommend consulting and following the "UNCSAAL Recommendations" drawn up on the basis of the relative UNI, UNI-EN and UNI-CNR standards.

Check that the arrow on the profile is compatible with the arrow on the glass used.

The curves represent the maximum width of the door as a function of its height and wind pressure.

The frame is considered to have 2 doors.

The curves are calculated on the basis of the elastic deformation of 1/200 of the height of the window.



Diagramma dei limiti di impiego

Use Limits Diagram

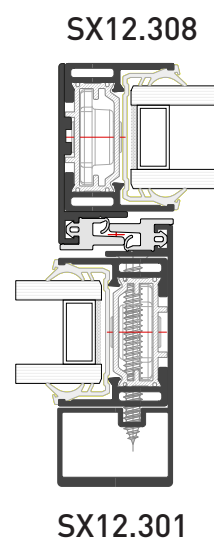
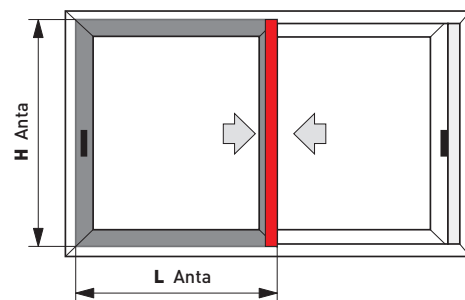
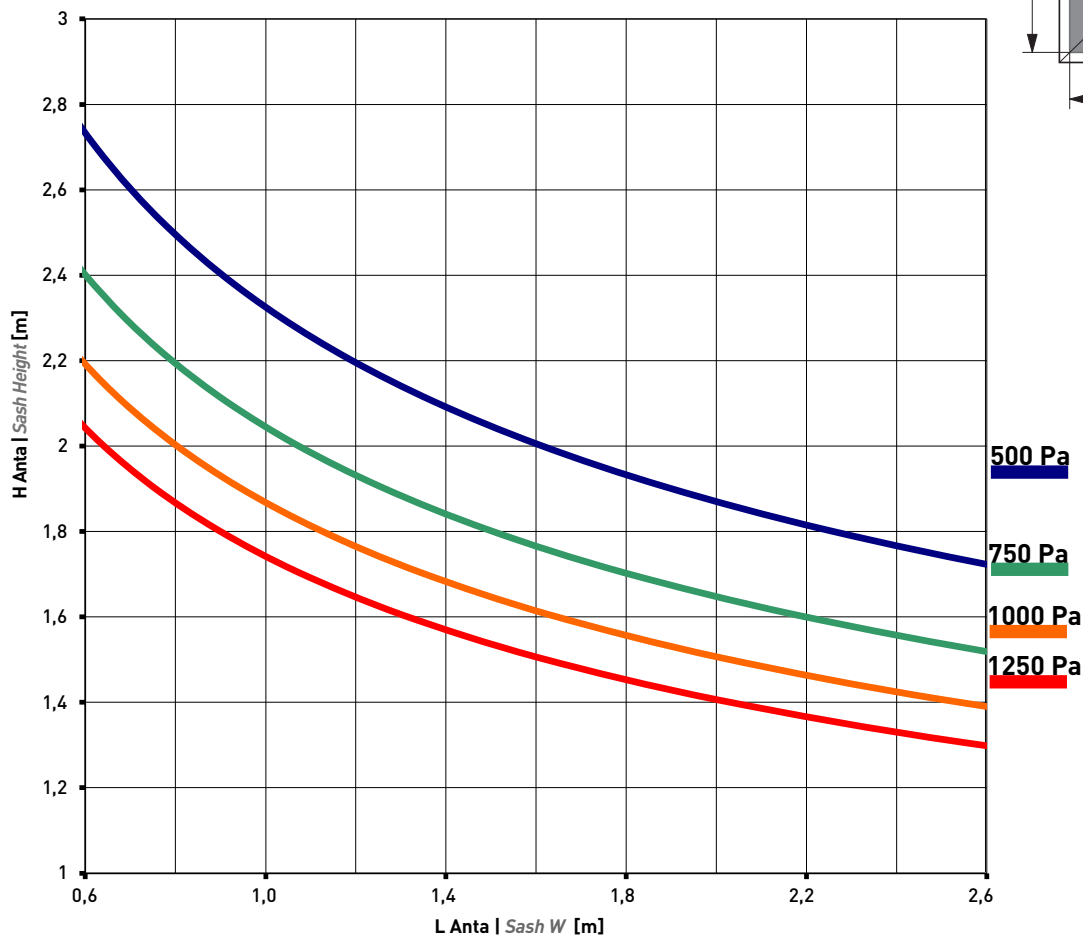

Infisso a 2 ante. Deflessione del nodo centrale

Il dimensionamento risultante dal grafico è solo indicativo. Il progettista o il serramentista, nel determinare le dimensioni massime dei serramenti, dovrà considerare e valutare, oltre le dimensioni ed il momento d'inerzia dei profilati, anche le caratteristiche applicative e meteorologiche quali l'altezza dal suolo, l'esposizione alla pioggia e la velocità dei venti nella zona.

Per questi dati consigliamo di consultare e seguire le "Raccomandazioni UNCSAAL" elaborate sulla base delle norme UNI, UNI-EN e UNI-CNR esistenti in merito.

Verificare che la freccia del profilato sia compatibile con quella del vetro utilizzato.

Le curve rappresentano la larghezza massima dell'anta in funzione della sua altezza e della pressione del vento.

Il serramento è considerato a 2 ante uguali.

Le curve sono calcolate sulla base della deformazione elastica di 1/200 dell'altezza del serramento.

Double sash windows. Deflection of the central node

In determining the maximum dimensions of the doors and windows, in addition to the dimensions and moment of inertia of the profiles, the designer or manufacturer must also consider and evaluate the application and meteorological conditions such as the height from the ground, exposure to rain and the speed of the winds in the area.

For these data, we recommend consulting and following the "UNCSAAL Recommendations" drawn up on the basis of the relative UNI, UNI-EN and UNI-CNR standards.

Check that the arrow on the profile is compatible with the arrow on the glass used.

The curves represent the maximum width of the door as a function of its height and wind pressure.

The frame is considered to have 2 doors.

The curves are calculated on the basis of the elastic deformation of 1/200 of the height of the window.



Diagramma dei limiti di impiego

Use Limits Diagram

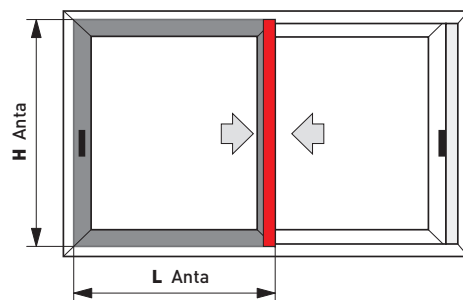
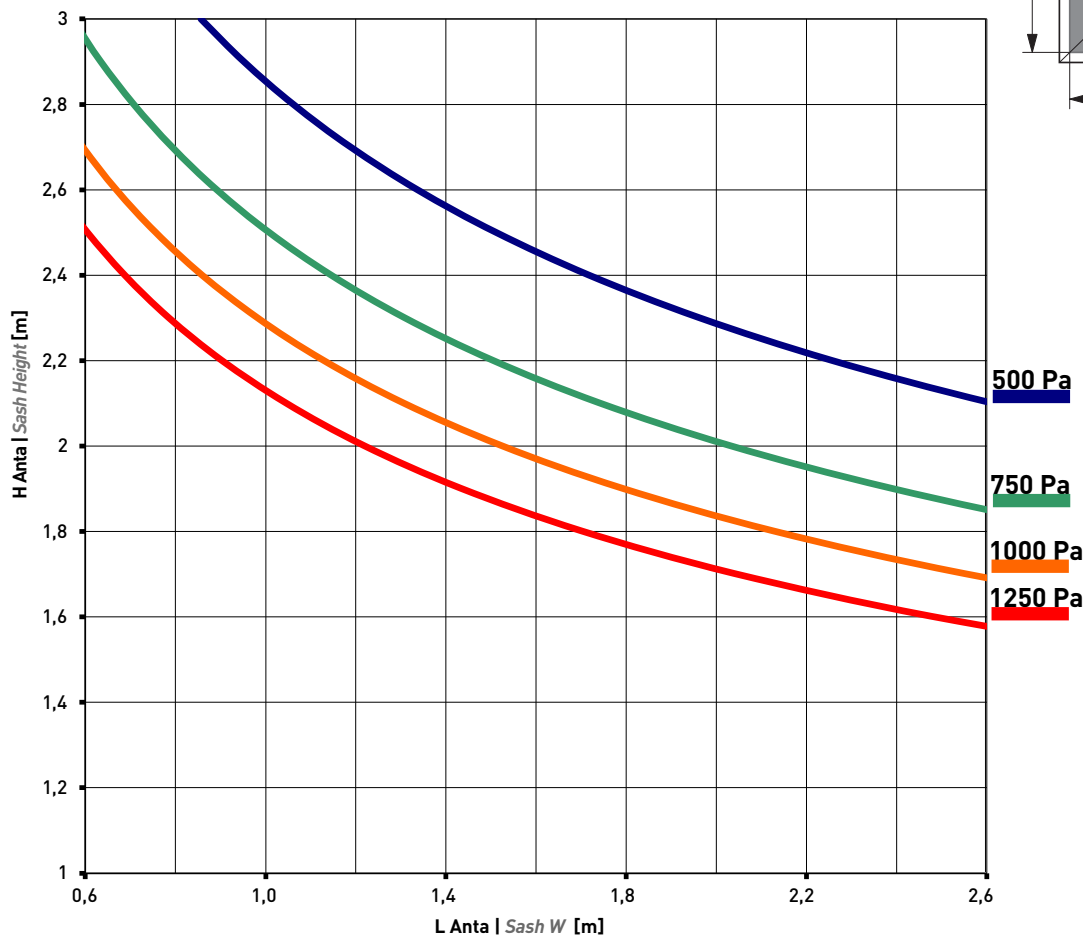

SX12.308

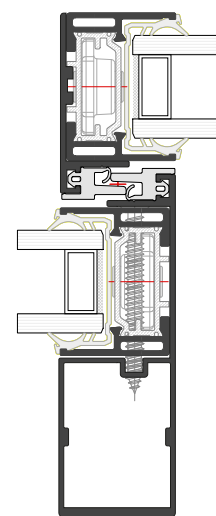

SX12.302

Infisso a 2 ante.

Deflessione del nodo centrale

Il dimensionamento risultante dal grafico è solo indicativo. Il progettista o il serramentista, nel determinare le dimensioni massime dei serramenti, dovrà considerare e valutare, oltre le dimensioni ed il momento d'inerzia dei profilati, anche le caratteristiche applicative e meteorologiche quali l'altezza dal suolo, l'esposizione alla pioggia e la velocità dei venti nella zona.

Per questi dati consigliamo di consultare e seguire le "Raccomandazioni UNCSAAL" elaborate sulla base delle norme UNI, UNI-EN e UNI-CNR esistenti in merito.

Verificare che la freccia del profilato sia compatibile con quella del vetro utilizzato.

Le curve rappresentano la larghezza massima dell'anta in funzione della sua altezza e della pressione del vento.

Il serramento è considerato a 2 ante uguali.

Le curve sono calcolate sulla base della deformazione elastica di 1/200 dell'altezza del serramento.

Double sash windows.

Deflection of the central node

In determining the maximum dimensions of the doors and windows, in addition to the dimensions and moment of inertia of the profiles, the designer or manufacturer must also consider and evaluate the application and meteorological conditions such as the height from the ground, exposure to rain and the speed of the winds in the area.

For these data, we recommend consulting and following the "UNCSAAL Recommendations" drawn up on the basis of the relative UNI, UNI-EN and UNI-CNR standards.

Check that the arrow on the profile is compatible with the arrow on the glass used.

The curves represent the maximum width of the door as a function of its height and wind pressure.

The frame is considered to have 2 doors.

The curves are calculated on the basis of the elastic deformation of 1/200 of the height of the window.



Diagramma dei limiti di impiego

Use Limits Diagram

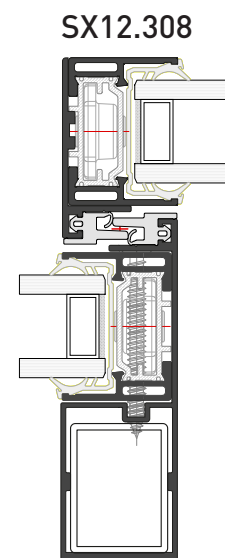
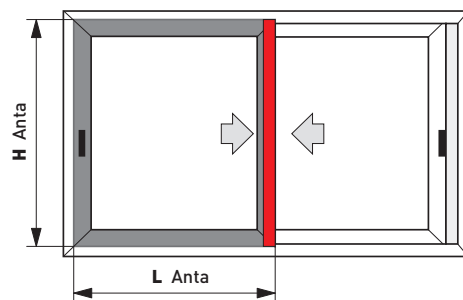
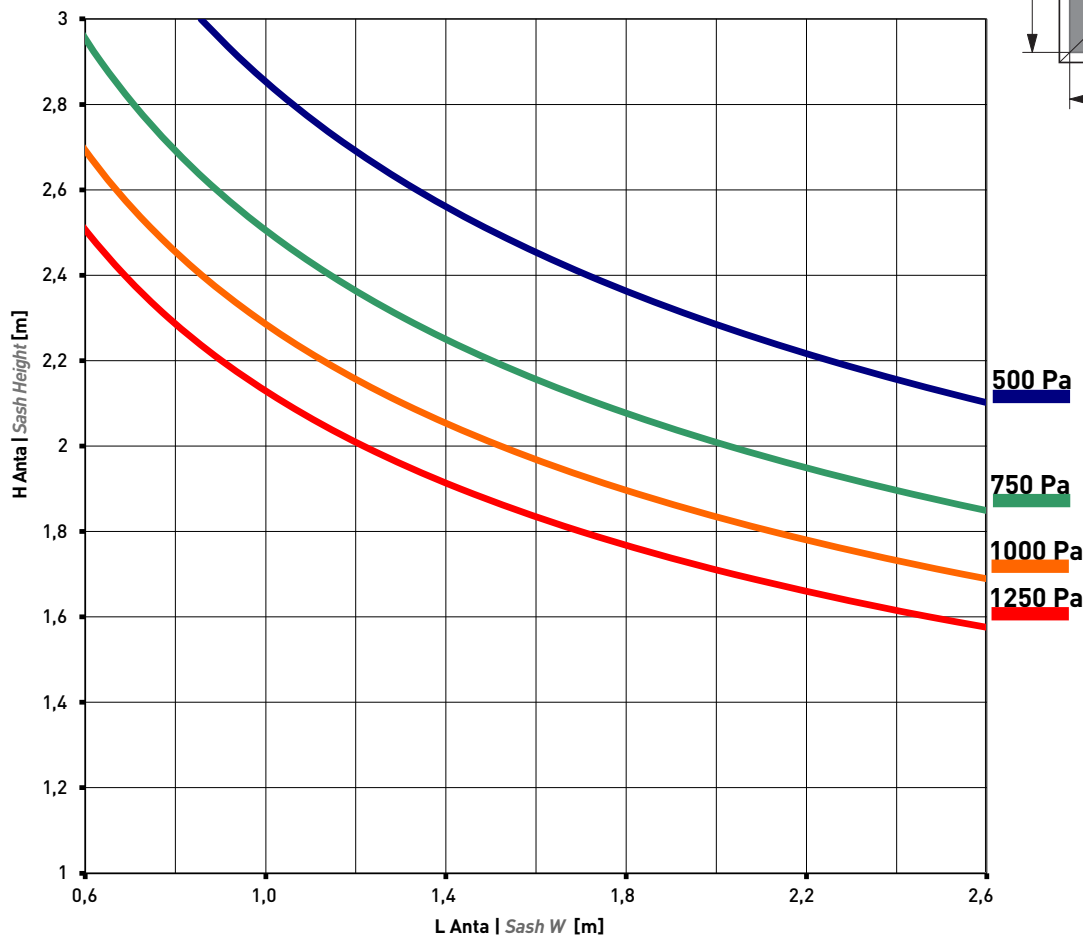

SX12.302 +
Rinforzo 30X40x2

Infisso a 2 ante. Deflessione del nodo centrale

Il dimensionamento risultante dal grafico è solo indicativo. Il progettista o il serramentista, nel determinare le dimensioni massime dei serramenti, dovrà considerare e valutare, oltre le dimensioni ed il momento d'inerzia dei profilati, anche le caratteristiche applicative e meteorologiche quali l'altezza dal suolo, l'esposizione alla pioggia e la velocità dei venti nella zona.

Per questi dati consigliamo di consultare e seguire le "Raccomandazioni UNCSAAL" elaborate sulla base delle norme UNI, UNI-EN e UNI-CNR esistenti in merito.

Verificare che la freccia del profilato sia compatibile con quella del vetro utilizzato.

Le curve rappresentano la larghezza massima dell'anta in funzione della sua altezza e della pressione del vento.

Il serramento è considerato a 2 ante uguali.

Le curve sono calcolate sulla base della deformazione elastica di 1/200 dell'altezza del serramento.

Double sash windows. Deflection of the central node

In determining the maximum dimensions of the doors and windows, in addition to the dimensions and moment of inertia of the profiles, the designer or manufacturer must also consider and evaluate the application and meteorological conditions such as the height from the ground, exposure to rain and the speed of the winds in the area.

For these data, we recommend consulting and following the "UNCSAAL Recommendations" drawn up on the basis of the relative UNI, UNI-EN and UNI-CNR standards.

Check that the arrow on the profile is compatible with the arrow on the glass used.

The curves represent the maximum width of the door as a function of its height and wind pressure.

The frame is considered to have 2 doors.

The curves are calculated on the basis of the elastic deformation of 1/200 of the height of the window.



Diagramma dei limiti di impiego

Use Limits Diagram

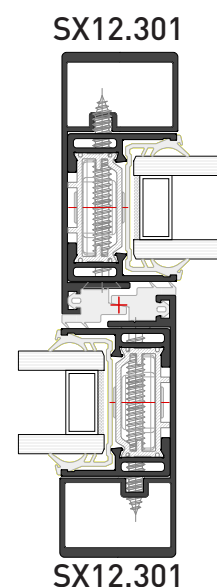
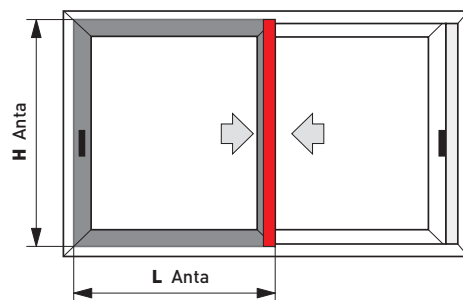
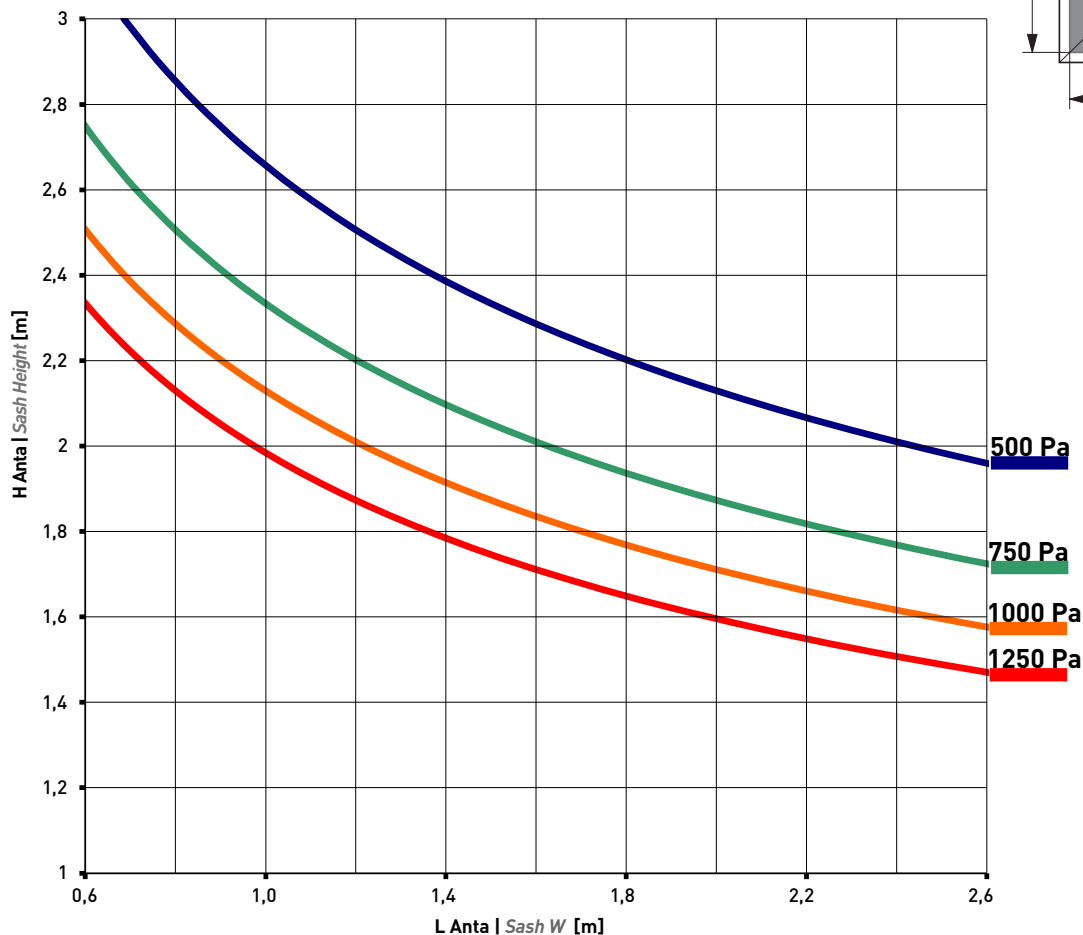

Infisso a 2 ante. Deflessione del nodo centrale

Il dimensionamento risultante dal grafico è solo indicativo. Il progettista o il serramentista, nel determinare le dimensioni massime dei serramenti, dovrà considerare e valutare, oltre le dimensioni ed il momento d'inerzia dei profilati, anche le caratteristiche applicative e meteorologiche quali l'altezza dal suolo, l'esposizione alla pioggia e la velocità dei venti nella zona.

Per questi dati consigliamo di consultare e seguire le "Raccomandazioni UNCSAAL" elaborate sulla base delle norme UNI, UNI-EN e UNI-CNR esistenti in merito.

Verificare che la freccia del profilato sia compatibile con quella del vetro utilizzato.

Le curve rappresentano la larghezza massima dell'anta in funzione della sua altezza e della pressione del vento.

Il serramento è considerato a 2 ante uguali.

Le curve sono calcolate sulla base della deformazione elastica di 1/200 dell'altezza del serramento.

Double sash windows. Deflection of the central node

In determining the maximum dimensions of the doors and windows, in addition to the dimensions and moment of inertia of the profiles, the designer or manufacturer must also consider and evaluate the application and meteorological conditions such as the height from the ground, exposure to rain and the speed of the winds in the area.

For these data, we recommend consulting and following the "UNCSAAL Recommendations" drawn up on the basis of the relative UNI, UNI-EN and UNI-CNR standards.

Check that the arrow on the profile is compatible with the arrow on the glass used.

The curves represent the maximum width of the door as a function of its height and wind pressure.

The frame is considered to have 2 doors.

The curves are calculated on the basis of the elastic deformation of 1/200 of the height of the window.



Diagramma dei limiti di impiego

Use Limits Diagram

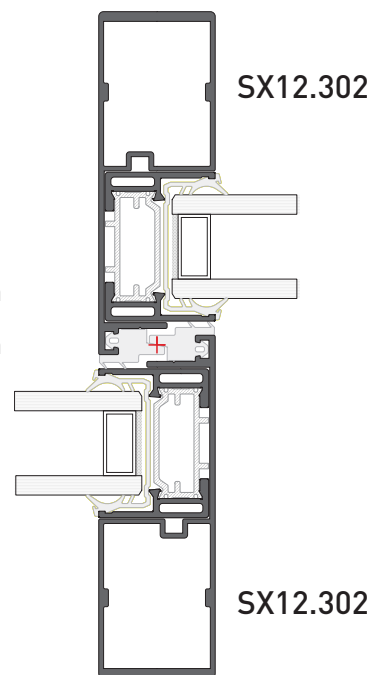
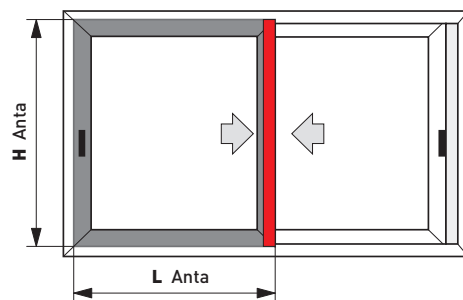
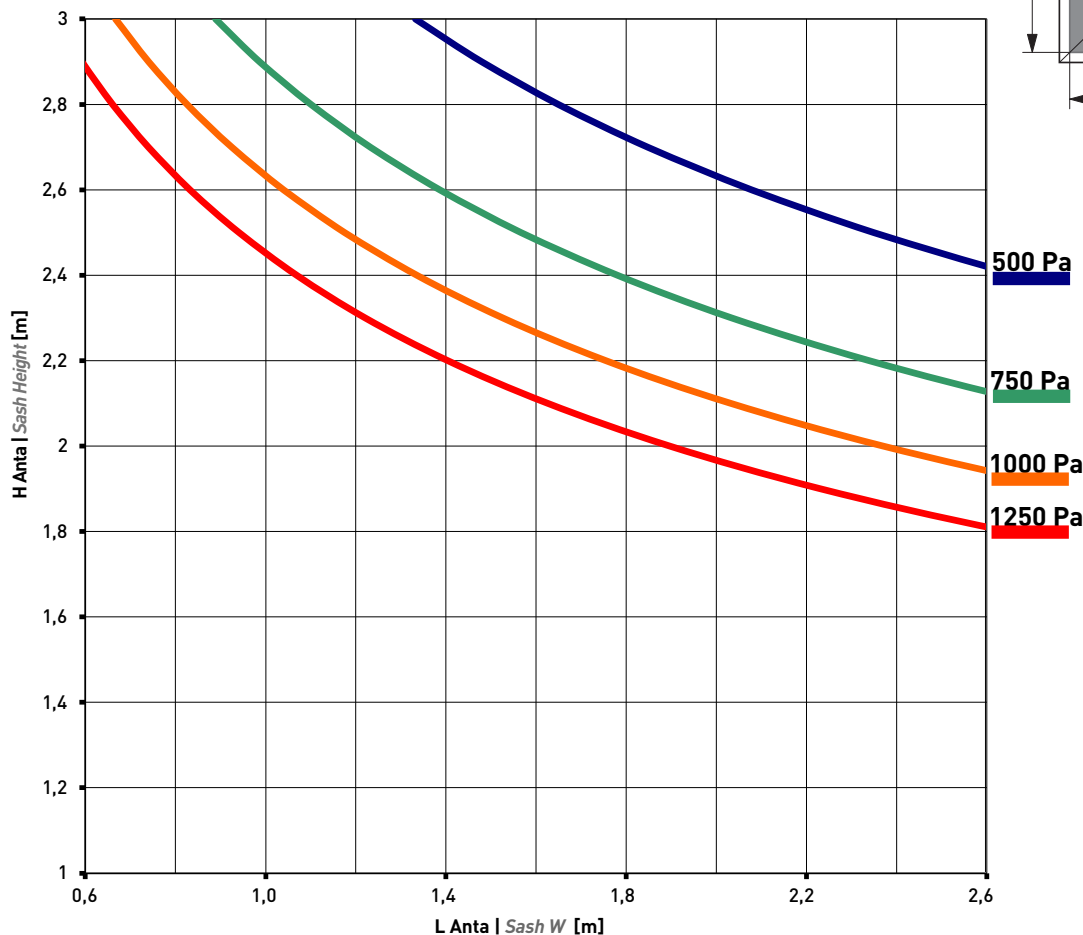

Infisso a 2 ante. Deflessione del nodo centrale

Il dimensionamento risultante dal grafico è solo indicativo. Il progettista o il serramentista, nel determinare le dimensioni massime dei serramenti, dovrà considerare e valutare, oltre le dimensioni ed il momento d'inerzia dei profilati, anche le caratteristiche applicative e meteorologiche quali l'altezza dal suolo, l'esposizione alla pioggia e la velocità dei venti nella zona.

Per questi dati consigliamo di consultare e seguire le "Raccomandazioni UNCSAAL" elaborate sulla base delle norme UNI, UNI-EN e UNI-CNR esistenti in merito.

Verificare che la freccia del profilato sia compatibile con quella del vetro utilizzato.

Le curve rappresentano la larghezza massima dell'anta in funzione della sua altezza e della pressione del vento.

Il serramento è considerato a 2 ante uguali.

Le curve sono calcolate sulla base della deformazione elastica di 1/200 dell'altezza del serramento.

Double sash windows. Deflection of the central node

In determining the maximum dimensions of the doors and windows, in addition to the dimensions and moment of inertia of the profiles, the designer or manufacturer must also consider and evaluate the application and meteorological conditions such as the height from the ground, exposure to rain and the speed of the winds in the area.

For these data, we recommend consulting and following the "UNCSAAL Recommendations" drawn up on the basis of the relative UNI, UNI-EN and UNI-CNR standards.

Check that the arrow on the profile is compatible with the arrow on the glass used.

The curves represent the maximum width of the door as a function of its height and wind pressure.

The frame is considered to have 2 doors.

The curves are calculated on the basis of the elastic deformation of 1/200 of the height of the window.



Diagramma dei limiti di impiego

Use Limits Diagram

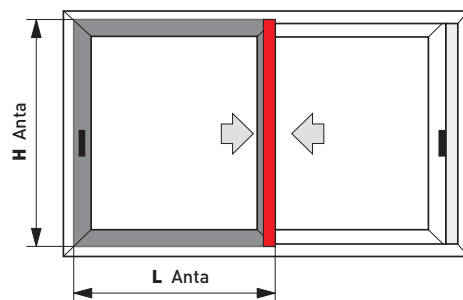
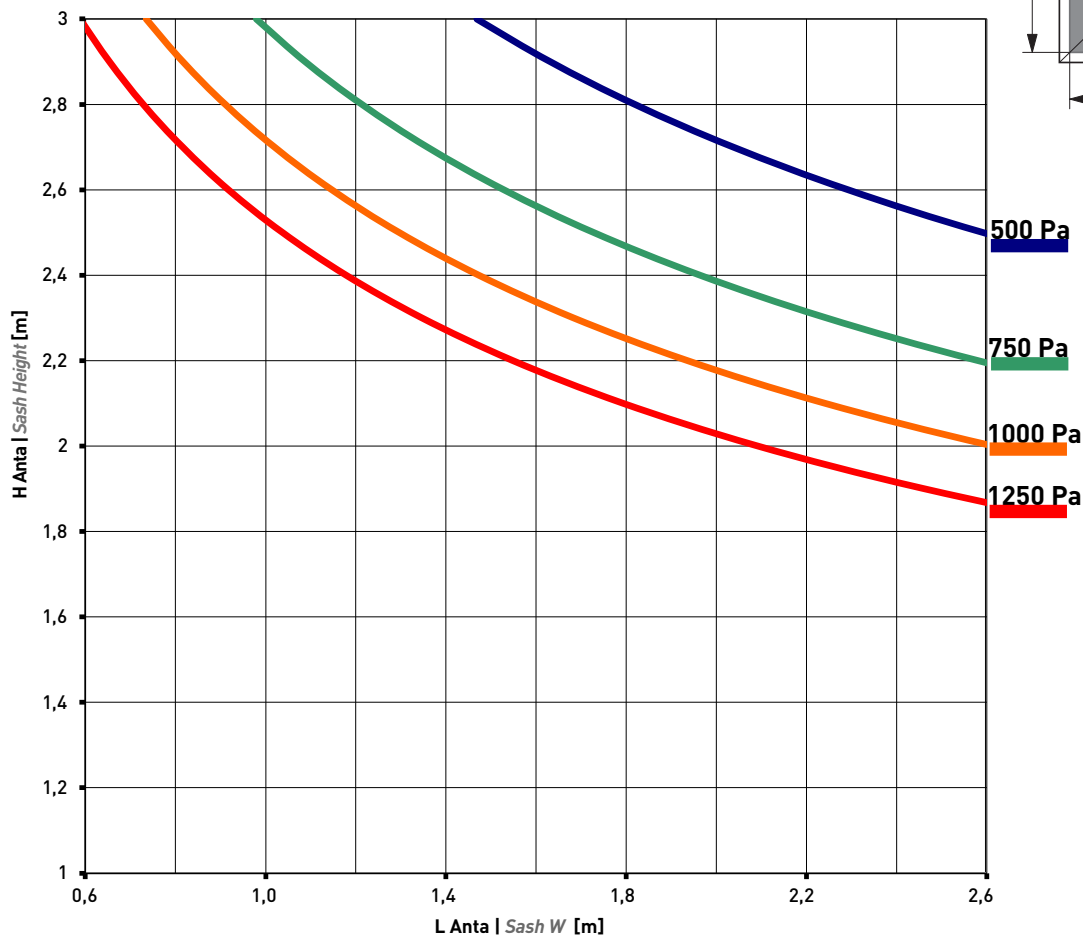

SX12.302

Rinforzo ACCIAIO 30X40x2
Reinforcement Steel 30X40x2

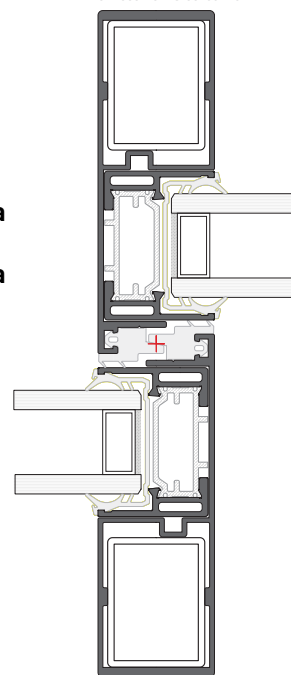

SX12.302

Rinforzo ACCIAIO 30X40x2
Reinforcement Steel 30X40x2

Infisso a 2 ante. Deflessione del nodo centrale

Il dimensionamento risultante dal grafico è solo indicativo. Il progettista o il serramentista, nel determinare le dimensioni massime dei serramenti, dovrà considerare e valutare, oltre le dimensioni ed il momento d'inerzia dei profilati, anche le caratteristiche applicative e meteorologiche quali l'altezza dal suolo, l'esposizione alla pioggia e la velocità dei venti nella zona.

Per questi dati consigliamo di consultare e seguire le "Raccomandazioni UNCSAAL" elaborate sulla base delle norme UNI, UNI-EN e UNI-CNR esistenti in merito.

Verificare che la freccia del profilato sia compatibile con quella del vetro utilizzato.

Le curve rappresentano la larghezza massima dell'anta in funzione della sua altezza e della pressione del vento.

Il serramento è considerato a 2 ante uguali.

Le curve sono calcolate sulla base della deformazione elastica di 1/200 dell'altezza del serramento.

Double sash windows. Deflection of the central node

In determining the maximum dimensions of the doors and windows, in addition to the dimensions and moment of inertia of the profiles, the designer or manufacturer must also consider and evaluate the application and meteorological conditions such as the height from the ground, exposure to rain and the speed of the winds in the area.

For these data, we recommend consulting and following the "UNCSAAL Recommendations" drawn up on the basis of the relative UNI, UNI-EN and UNI-CNR standards.

Check that the arrow on the profile is compatible with the arrow on the glass used.

The curves represent the maximum width of the door as a function of its height and wind pressure.

The frame is considered to have 2 doors.

The curves are calculated on the basis of the elastic deformation of 1/200 of the height of the window.



Profili
Profiles

Gruppo B

Elenco Profili
Profili Scala 1:1

Profiles List
Profiles Scale 1:1

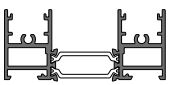

SX85.101			Tavola Table B05
Telaio binario 2 vie			
2-way track frame			
Peso Weight Kg/ml 1.794 J_x 53.05 cm ⁴ W_x 12.48 cm ³ J_y 5.73 cm ⁴ W_y 2.7 cm ³			

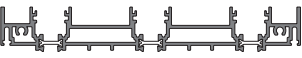
SX12.145			Tavola Table B09
Soglia Filo Pavimento 3 Vie			
3-way floor-level threshold			
Peso Weight Kg/ml 2.985 J_x 0.00 cm ⁴ W_x 0.00 cm ³ J_y 0.00 cm ⁴ W_y 0.00 cm ³			

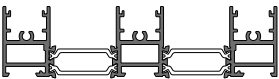
SX85.102			Tavola Table B05
Telaio binario 3 vie			
3-way track frame			
Peso Weight Kg/ml 2.857 J_x 209.29 cm ⁴ W_x 28.86 cm ³ J_y 8.24 cm ⁴ W_y 4.09 cm ³			

SX11.149			Tavola Table B06
Telaio Sogliai Ribassata 1 Arta			
Main Frame Lowered Threshold single Track			
Peso Weight Kg/ml 0.463 J_x 0 cm ⁴ W_x 0 cm ³ J_y 0 cm ⁴ W_y 0 cm ³			

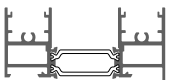
SX85.103			Tavola Table B05
Telaio binario 2 vie c/coprifilo			
2-way track frame w/casing			
Peso Weight Kg/ml 1.919 J_x 53.48 cm ⁴ W_x 12.51 cm ³ J_y 5.73 cm ⁴ W_y 2.7 cm ³			

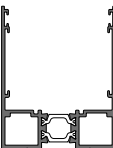
SX12.153			Tavola Table B06
Telaio via singola - mm. 60.3			
Single way frame - mm. 60.3			
Peso Weight Kg/ml 1.614 J_x 31.71 cm ⁴ W_x 10.52 cm ³ J_y 26.76 cm ⁴ W_y 5.34 cm ³			

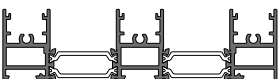
SX85.104			Tavola Table B05
Telaio binario 3 vie c/coprifilo			
3-way track frame w/casing			
Peso Weight Kg/ml 2.982 J_x 209.46 cm ⁴ W_x 28.99 cm ³ J_y 8.24 cm ⁴ W_y 4.09 cm ³			

SX11.154			Tavola Table B06
Telaio binario singolo			
Single track frame			
Peso Weight Kg/ml 1.230 J_x 9.37 cm ⁴ W_x 3.75 cm ³ J_y 6.27 cm ⁴ W_y 2.13 cm ³			

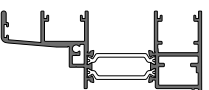
SX85.105			Tavola Table B06
Telaio binario 2 vie c/guida Zanzariera			
2-way track frame w/guide Mosquito net			
Peso Weight Kg/ml 1.819 J_x 43.05 cm ⁴ W_x 10.48 cm ³ J_y 4.73 cm ⁴ W_y 2.2 cm ³			

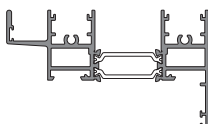
SX85.173			Tavola Table B07
Telaio binario 2 vie c/coprifilo + Zanzariera			
2-way track frame w/casing + Mosquito Net			
Peso Weight Kg/ml 2.142 J_x 9.49 cm ⁴ W_x 3.87 cm ³ J_y 6.39 cm ⁴ W_y 2.25 cm ³			

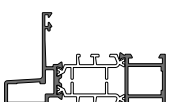
SX85.136			Tavola Table B06
Telaio binario 3 vie c/guida Zanzariera			
3-way track frame w/guide Mosquito net			
Peso Weight Kg/ml 1.362 J_x 32.66 cm ⁴ W_x 7.57 cm ³ J_y 5.36 cm ⁴ W_y 1.55 cm ³			

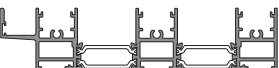
SX85.174			Tavola Table B08
Telaio binario 3 vie + Zanzariera			
3-way track frame w/casing + Mosquito Net			
Peso Weight Kg/ml 3.080 J_x 0.12 cm ⁴ W_x 0.12 cm ³ J_y 0.12 cm ⁴ W_y 0.12 cm ³			

SX12.143			Tavola Table B09
Soglia Filo Pavimento Monovia			
1-way track floor-level threshold			
Peso Weight Kg/ml 1.251 J_x 0.00 cm ⁴ W_x 0.00 cm ³ J_y 0.00 cm ⁴ W_y 0.00 cm ³			

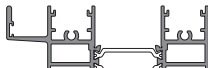
SX85.175			Tavola Table B07
Telaio binario 2 vie c/guida Zanzariera			
2-way track frame w/guide Mosquito net			
Peso Weight Kg/ml 2.017 J_x 31.83 cm ⁴ W_x 10.64 cm ³ J_y 26.88 cm ⁴ W_y 5.46 cm ³			

SX12.144			Tavola Table B09
Soglia Filo Pavimento 3 Vie			
2-way floor-level threshold			
Peso Weight Kg/ml 2.118 J_x 0.00 cm ⁴ W_x 0.00 cm ³ J_y 0.00 cm ⁴ W_y 0.00 cm ³			

SX11.176			Tavola Table B08
Telaio binario 2 vie ribassato			
Low-profile 2-way track frame			
Peso Weight Kg/ml 1.565 J_x 40.55 cm ⁴ W_x 9.54 cm ³ J_y 1.8 cm ⁴ W_y 1.67 cm ³			

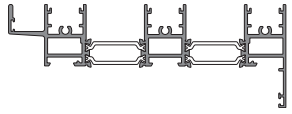

SX85.177			Tavola Table B08
Telaio binario 3 vie c/coprifilo + Zanzariera			
<i>2-way track frame w/guide Mosquito net</i>			
Peso Weight Kg/ml 3.205			
J_x 31.83 cm ⁴ W_x 10.64 cm ³	J_y 26.88 cm ⁴ W_y 5.46 cm ³		

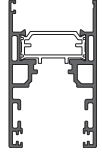
SX85.205			Tavola Table B14
Anta infilare Alzante 1 sede guarn.			
<i>Lift-and-slide glass door 1 seat</i>			
Peso Weight Kg/ml 1.764			
J_x 21.41 cm ⁴ W_x 9.28 cm ³	J_y 23.15 cm ⁴ W_y 5.72 cm ³		

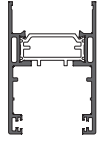
SX85.201			Tavola Table B13
Anta infilare maggiorata			
<i>Oversized mortise glass door</i>			
Peso Weight Kg/ml 1.392			
J_x 17.87 cm ⁴ W_x 7.77 cm ³	J_y 15.39 cm ⁴ W_y 4.15 cm ³		

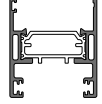
SX12.206			Tavola Table B10
Anta infilare 1 sede guarnizione			
<i>Mortise glass door 1 gasket seat</i>			
Peso Weight Kg/ml 1.153			
J_x 13.69 cm ⁴ W_x 5.93 cm ³	J_y 6.3 cm ⁴ W_y 2.14 cm ³		

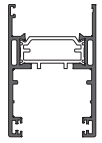
SX85.202			Tavola Table B13
Anta infilare maggiorata 1 sede guarn.			
<i>Oversized mortise glass door 1 seat gasket</i>			
Peso Weight Kg/ml 1.396			
J_x 17.91 cm ⁴ W_x 7.77 cm ³	J_y 15.39 cm ⁴ W_y 4.15 cm ³		

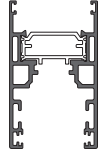
SX85.206			Tavola Table B14
Anta infilare Alzante 2 sede guarn.			
<i>Lift-and-slide glass door 2 seat gasket</i>			
Peso Weight Kg/ml 1.768			
J_x 21.45 cm ⁴ W_x 9.32 cm ³	J_y 23.39 cm ⁴ W_y 5.8 cm ³		

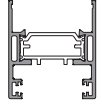
SX12.203			Tavola Table B10
Anta infilare			
<i>Mortise glass door</i>			
Peso Weight Kg/ml 1.150			
J_x 14.03 cm ⁴ W_x 6.1 cm ³	J_y 6.51 cm ⁴ W_y 2.25 cm ³		

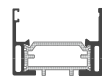
SX12.207			Tavola Table B10
Anta infilare ridotta 1 sede guarnizione			
<i>Reduced mortise glass door 1 gasket seat</i>			
Peso Weight Kg/ml 0.841			
J_x 8.75 cm ⁴ W_x 3.78 cm ³	J_y 2.19 cm ⁴ W_y 1 cm ³		

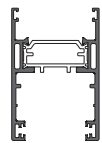
SX85.203			Tavola Table B13
Anta infilare maggiorata 2 sede guarn.			
<i>Oversized mortise glass door 2 gasket</i>			
Peso Weight Kg/ml 1.400			
J_x 17.95 cm ⁴ W_x 7.8 cm ³	J_y 15.72 cm ⁴ W_y 4.26 cm ³		

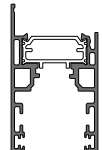
SX85.207			Tavola Table B14
Anta infilare Alzante 1 sede guarn. c/Fermavetro			
<i>Glass door mortise magg. 1 gasket w/ Glazing bead</i>			
Peso Weight Kg/ml 1.695			
J_x 18.81 cm ⁴ W_x 20.14 cm ³	J_y 18.93 cm ⁴ W_y 20.01 cm ³		

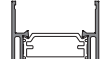
SX12.204			Tavola Table B10
Anta infilare ridotta			
<i>Reduced mortise glass door</i>			
Peso Weight Kg/ml 0.840			
J_x 9.08 cm ⁴ W_x 3.95 cm ³	J_y 2.21 cm ⁴ W_y 1.03 cm ³		

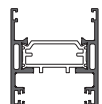
SX12.208			Tavola Table B10
Anta infilare 2 sede guarnizione			
<i>Mortise glass door 2 seat gasket</i>			
Peso Weight Kg/ml 1.156			
J_x 13.73 cm ⁴ W_x 5.97 cm ³	J_y 6.39 cm ⁴ W_y 2.18 cm ³		

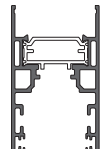
SX85.204			Tavola Table B14
Anta infilare Alzante			
<i>Lift-and-slide glass door</i>			
Peso Weight Kg/ml 1.760			
J_x 21.37 cm ⁴ W_x 9.28 cm ³	J_y 22.98 cm ⁴ W_y 5.72 cm ³		

SX85.208			Tavola Table B14
Anta infilare magg. 2 sede guarn. c/Fermavetro			
<i>Glass door mortise magg. 2 gasket w/ Glazing bead</i>			
Peso Weight Kg/ml 1.699			
J_x 18.81 cm ⁴ W_x 20.14 cm ³	J_y 18.93 cm ⁴ W_y 20.01 cm ³		

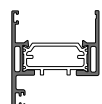
SX12.205			Tavola Table B11
Anta infilare per angolo			
<i>Corner mortise glass door</i>			
Peso Weight Kg/ml 0.995			
J_x 11.08 cm ⁴ W_x 4.1 cm ³	J_y 4.75 cm ⁴ W_y 1.82 cm ³		

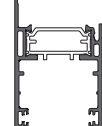
SX85.209			Tavola Table B13
Anta magg. 2 sede guarn. c/fermavetro			
<i>Oversized mortise glass door 2 gasket w/ Glazing Bead</i>			
Peso Weight Kg/ml 1.325			
J_x 15.55 cm ⁴ W_x 4.2 cm ³	J_y 11.53 cm ⁴ W_y 1.86 cm ³		

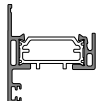

SX12.209			Tavola Table B10
Anta infilare ridotta 2 sede guarnizione			
<i>Reduced mortise glass door 2 gasket seat</i>			
Peso Weight Kg/ml	0.842		
J_x 8.79 cm ⁴ W_x 3.82 cm ³	J_y 2.24 cm ⁴ W_y 1.02 cm ³		

SX12.216			Tavola Table B11
Anta fermavetro per angolo			
<i>Glazing bead for corner</i>			
Peso Weight Kg/ml	0.927		
J_x 8.67 cm ⁴ W_x 2.8 cm ³	J_y 3.39 cm ⁴ W_y 1.18 cm ³		

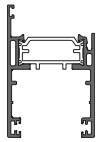
SX85.210			Tavola Table B13
Anta magg. 2 sede guar. c/fermavetro			
<i>Oversized mortise glass door 2 gasket w/ Glazing Bead</i>			
Peso Weight Kg/ml	1.329		
J_x 15.55 cm ⁴ W_x 4.2 cm ³	J_y 11.53 cm ⁴ W_y 1.86 cm ³		

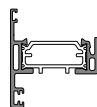
SX12.217			Tavola Table B11
Anta fermavetro per angolo 1 sede guarnizione			
<i>Glazing bead for corner 1 gasket seat</i>			
Peso Weight Kg/ml	0,930		
J_x 8.68 cm ⁴ W_x 2.9 cm ³	J_y 3.48 cm ⁴ W_y 1.22 cm ³		

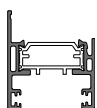
SX12.210			Tavola Table B12
Anta per fermavetro			
<i>Glazing bead door</i>			
Peso Weight Kg/ml	1.082		
J_x 12.24 cm ⁴ W_x 4.92 cm ³	J_y 4.69 cm ⁴ W_y 1.49 cm ³		

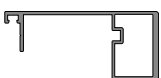
SX12.301			Tavola Table B15
Incontro centrale			
<i>Central meeting</i>			
Peso Weight Kg/ml	1.204		
J_x 28.09 cm ⁴ W_x 5.41 cm ³	J_y 5.68 cm ⁴ W_y 2.39 cm ³		

SX12.211			Tavola Table B12
Anta per fermavetro ridotta			
<i>Reduced glazing bead sash</i>			
Peso Weight Kg/ml	0.772		
J_x 7.24 cm ⁴ W_x 2.79 cm ³	J_y 1.46 cm ⁴ W_y 0.59 cm ³		

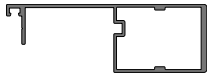
SX12.302			Tavola Table B15
Incontro centrale rinforzato			
<i>Reinforced central meeting</i>			
Peso Weight Kg/ml	1.267		
J_x 54.55 cm ⁴ W_x 8.44 cm ³	J_y 8.52 cm ⁴ W_y 3.77 cm ³		

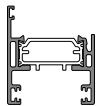
SX12.212			Tavola Table B12
Anta per fermavetro 1 sede guarnizione			
<i>Glazing bead door 1 gasket seat</i>			
Peso Weight Kg/ml	1.085		
J_x 12.27 cm ⁴ W_x 4.92 cm ³	J_y 4.8 cm ⁴ W_y 1.53 cm ³		

SX11.303			Tavola Table B16
Incontro centrale 4 anta			
<i>Central striker 4 doors</i>			
Peso Weight Kg/ml	0.485		
J_x 0 cm ⁴ W_x 0 cm ³	J_y 0 cm ⁴ W_y 0 cm ³		

SX12.213			Tavola Table B12
Anta per fermavetro ridotta 1 sede guarnizione			
<i>Door for reduced glazing bead 1 gasket seat</i>			
Peso Weight Kg/ml	0.773		
J_x 7.27 cm ⁴ W_x 2.79 cm ³	J_y 1.5 cm ⁴ W_y 0.62 cm ³		

SX12.303			Tavola Table B15
Incontro per 4 ante			
<i>Meeting for 4 doors</i>			
Peso Weight Kg/ml	0.766		
J_x 1.1 cm ⁴ W_x 0.05 cm ³	J_y 16.36 cm ⁴ W_y 3.18 cm ³		

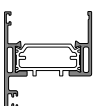
SX12.214			Tavola Table B11
Anta infilare angolo 1 sede guarnizione			
<i>Glass door mortise corner 1 seat gasket</i>			
Peso Weight Kg/ml	0.998		
J_x 10.71 cm ⁴ W_x 3.93 cm ³	J_y 4.62 cm ⁴ W_y 2.79 cm ³		

SX12.304			Tavola Table B15
Incontro anta per angolo interno			
<i>Door striker for internal corner</i>			
Peso Weight Kg/ml	0.418		
J_x 0.05 cm ⁴ W_x 0.03 cm ³	J_y 0 cm ⁴ W_y 0 cm ³		

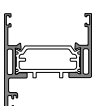
SX12.215			Tavola Table B11
Anta infilare angolo 2 sede guarnizione			
<i>Glass door mortise corner 2 seat gasket</i>			
Peso Weight Kg/ml	0.999		
J_x 10.77 cm ⁴ W_x 3.97 cm ³	J_y 4.7 cm ⁴ W_y 1.79 cm ³		

SX12.305			Tavola Table B15
Incontro angolo esterno principale			
<i>Main outdoor corner meeting</i>			
Peso Weight Kg/ml	1.385		
J_x 15.22 cm ⁴ W_x 4.36 cm ³	J_y 32.65 cm ⁴ W_y 5.6 cm ³		





SX12.306			Tavola Table B15
Incontro angolo esterno secondario			
<i>Secondary external corner striker</i>			
Peso Weight Kg/ml 0.717			
J_x 0.56 cm ⁴ W_x 0.44 cm ³	J_y 16.5 cm ⁴ W_y 3.26 cm ³		

SX85.506			Tavola Table B16
Fermavetro per Ante 3mm			
<i>Glazing bead for 3mm doors</i>			
Peso Weight Kg/ml 0.127			
J_x 0 cm ⁴ W_x 0 cm ³	J_y 0 cm ⁴ W_y 0 cm ³		

SX12.307			Tavola Table B15
Incontro centrale di sicurezza			
<i>Central Security Meeting</i>			
Peso Weight Kg/ml 1.287			
J_x 64.43 cm ⁴ W_x 10.5 cm ³	J_y 8.49 cm ⁴ W_y 3.77 cm ³		

SX85.507			Tavola Table B16
Fermavetro per Ante 6mm			
<i>Glazing bead for 6mm doors</i>			
Peso Weight Kg/ml 0.149			
J_x 0 cm ⁴ W_x 0 cm ³	J_y 0 cm ⁴ W_y 0 cm ³		

SX12.308			Tavola Table B16
Incontro centrale ridotto			
<i>Reduced central meeting</i>			
Peso Weight Kg/ml 0.432			
J_x 4.09 cm ⁴ W_x 0.39 cm ³	J_y 1.24 cm ⁴ W_y 0.22 cm ³		

SX11.632			Tavola Table B16
Porta Zananziera/Copri Anta Sup.			
<i>Mosquito Door/Sash Upper Cover</i>			
Peso Weight Kg/ml 0.361			
J_x 0 cm ⁴ W_x 0 cm ³	J_y 0 cm ⁴ W_y 0 cm ³		

SX85.501			Tavola Table B16
Profilo Aggiuntivo Binario Superiore			
<i>Additional profile top rail</i>			
Peso Weight Kg/ml 0.229			
J_x 0 cm ⁴ W_x 0 cm ³	J_y 0 cm ⁴ W_y 0 cm ³		

RC029			Tavola Table B16
Battuta Riportata Telaio			
<i>Frame Fence</i>			
Peso Weight Kg/ml 0.222			
J_x 0 cm ⁴ W_x 0 cm ³	J_y 0 cm ⁴ W_y 0 cm ³		

SX85.502			Tavola Table B16
Copribinario Telaio Laterale			
<i>Side Frame Track Cover</i>			
Peso Weight Kg/ml 0.326			
J_x 0 cm ⁴ W_x 0 cm ³	J_y 0 cm ⁴ W_y 0 cm ³		

XX70.503			Tavola Table B16
Coprifilo Planare per Clip			
<i>Planar Trim for Clip</i>			
Peso Weight Kg/ml 0.224			
J_x 0 cm ⁴ W_x 0 cm ³	J_y 0 cm ⁴ W_y 0 cm ³		

XX70.504			Tavola Table B16
Coprifilo Planare per Clip			
<i>Planar Trim for Clip</i>			
Peso Weight Kg/ml 0.238			
J_x 0 cm ⁴ W_x 0 cm ³	J_y 0 cm ⁴ W_y 0 cm ³		

SX85.505			Tavola Table B16
Binario in Alluminio			
<i>Aluminum Rail</i>			
Peso Weight Kg/ml 0.235			
J_x 0 cm ⁴ W_x 0 cm ³	J_y 0 cm ⁴ W_y 0 cm ³		

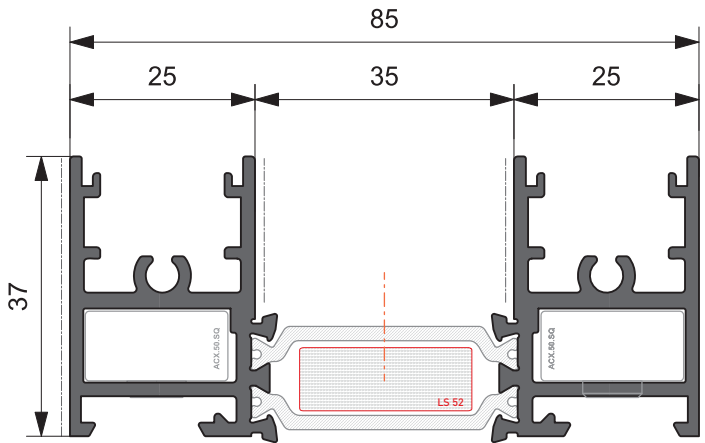

SX85.101

kg/ml 1,794
--- mm. 74,0

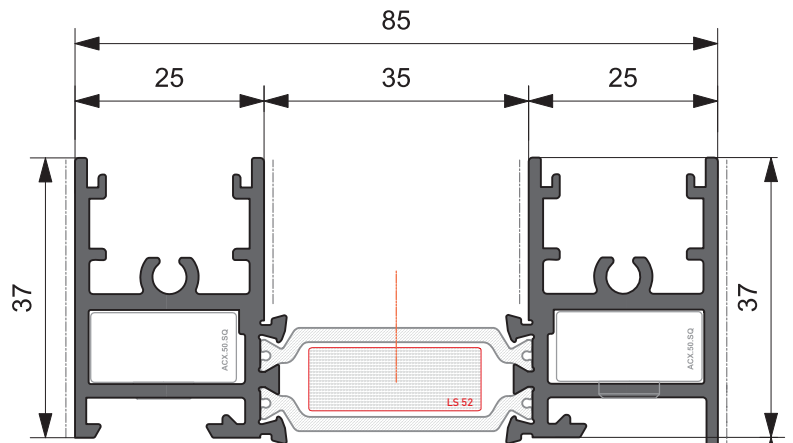

SX85.103

kg/ml 1,919
--- mm. 99,0

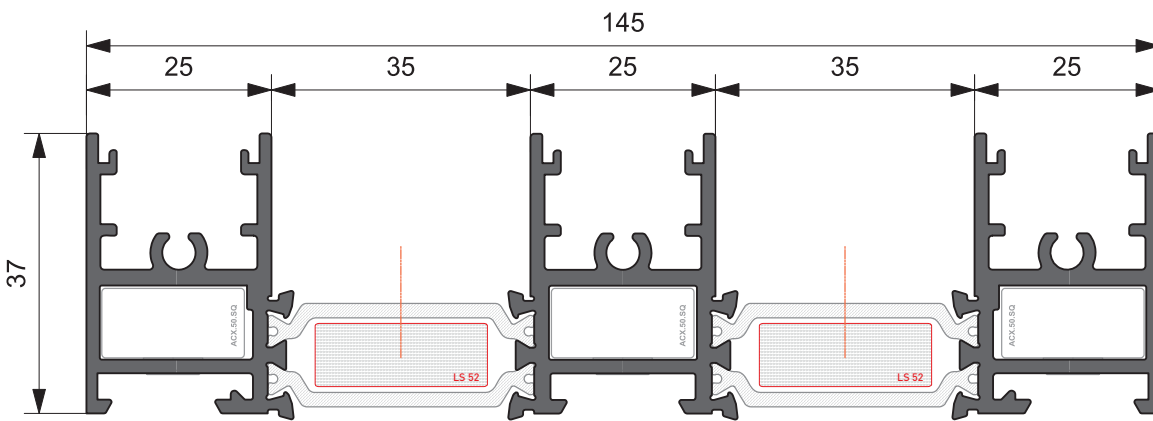

SX85.102

kg/ml 2,857
--- mm. 96,0

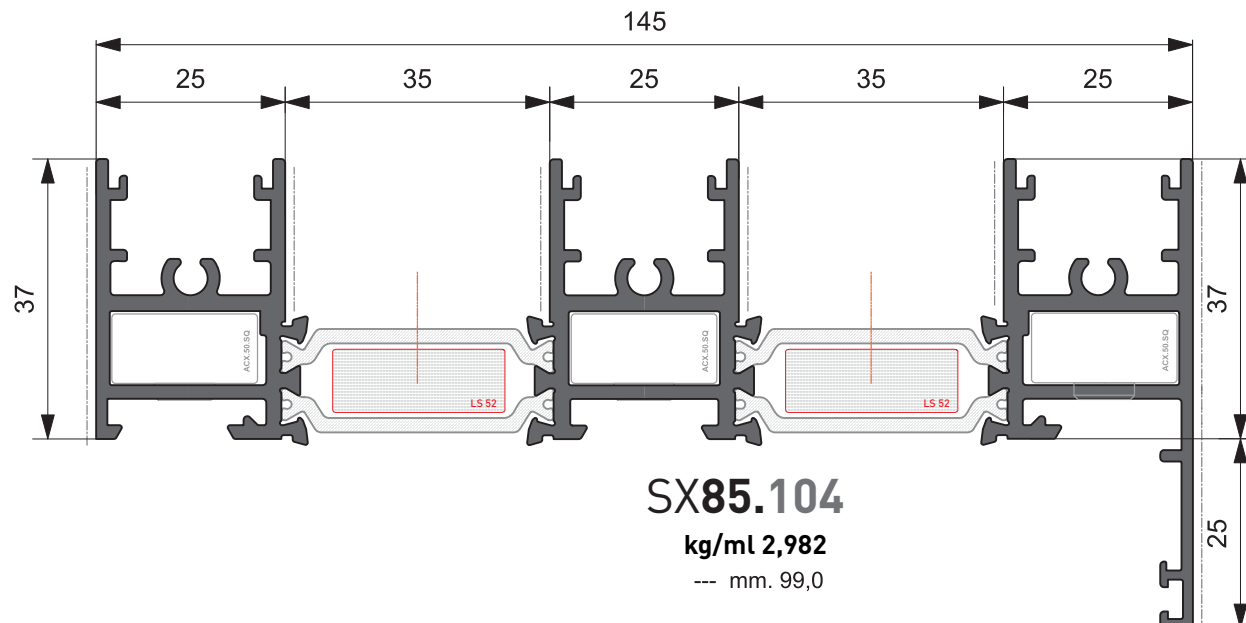

SX85.104

kg/ml 2,982
--- mm. 99,0



SX85.105

kg/ml 1,819

--- mm. 94,0

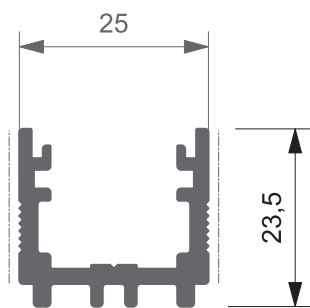
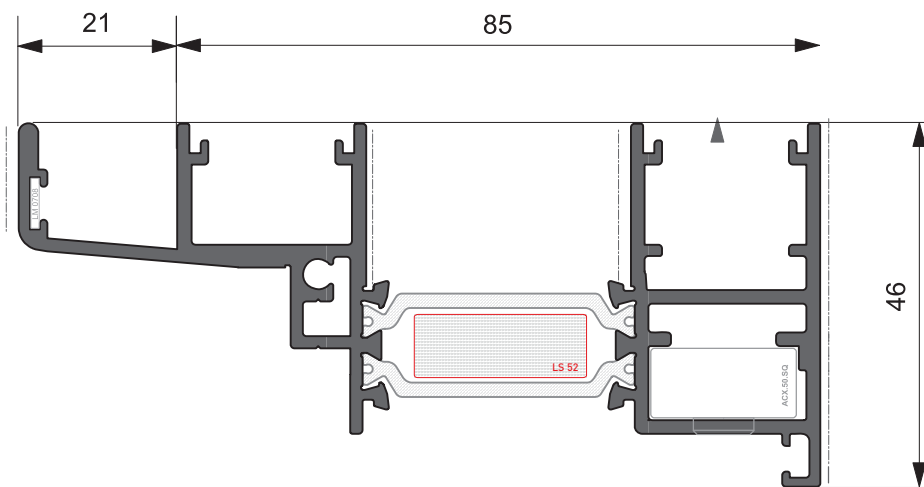

SX11.149

kg/ml 1,463

--- mm. 42,0

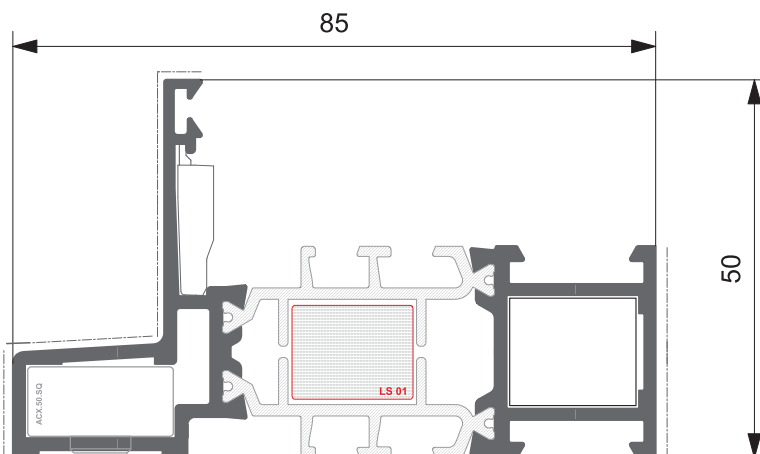

SX85.136

kg/ml 1,360

--- mm. 95,0

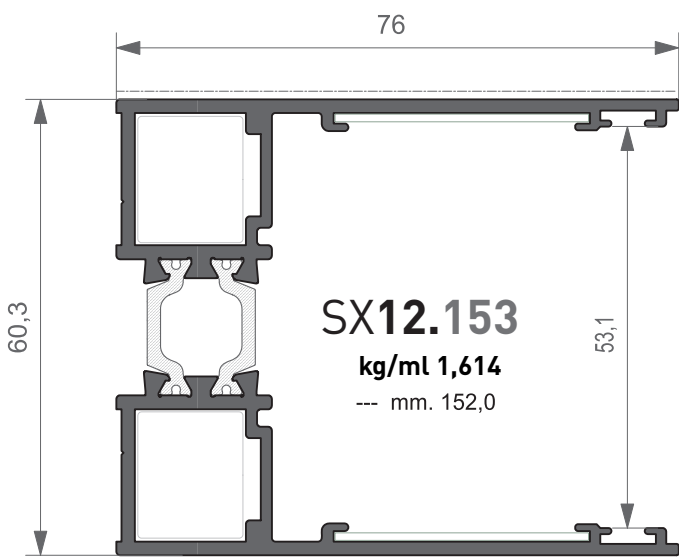

SX12.153

kg/ml 1,614

--- mm. 152,0

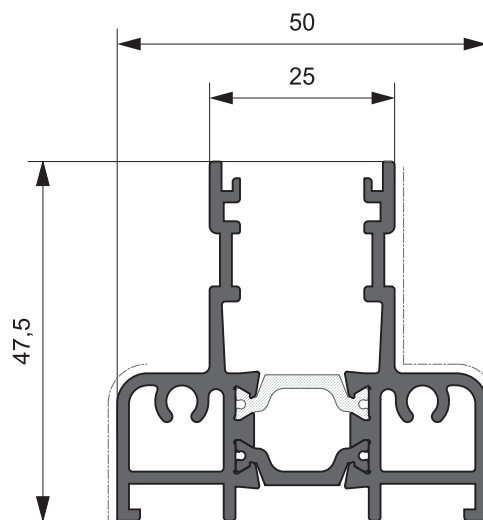

SX11.154

kg/ml 1,230

--- mm. 120,0

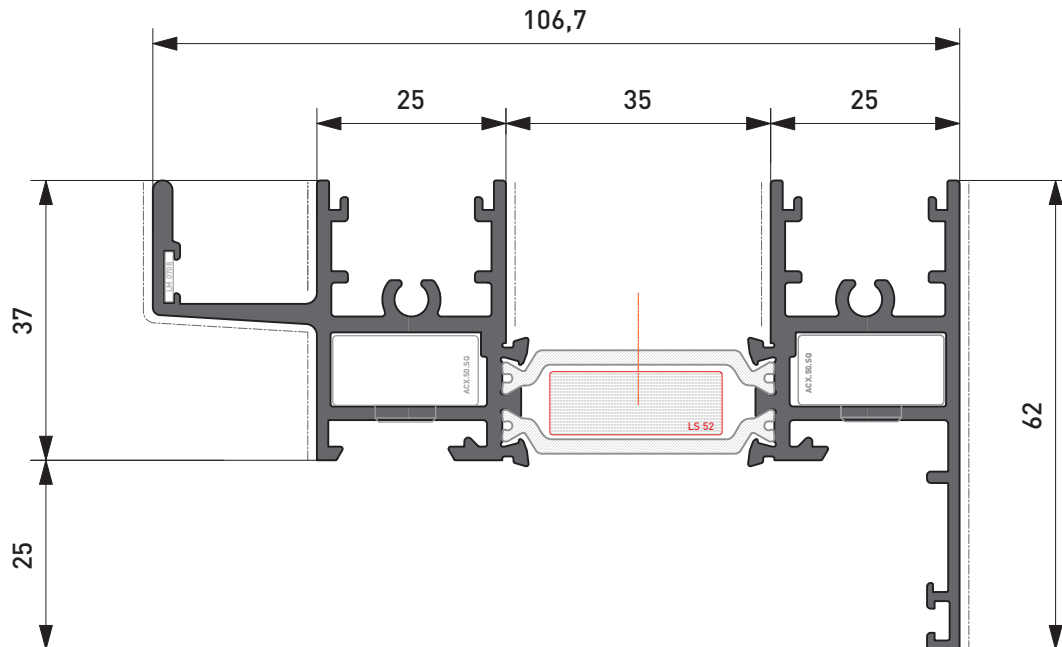

SX85.173

kg/ml 2,142
-- mm. 105.3

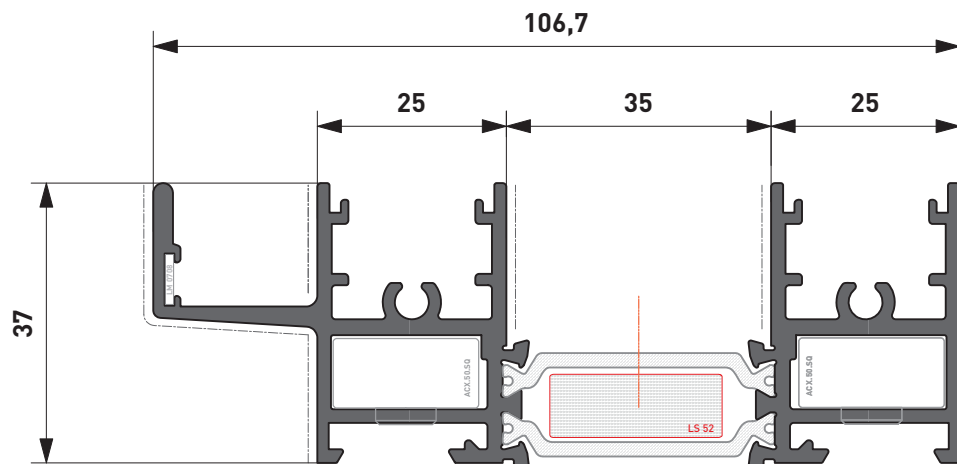

SX85.175

kg/ml 2,017
-- mm. 95.2

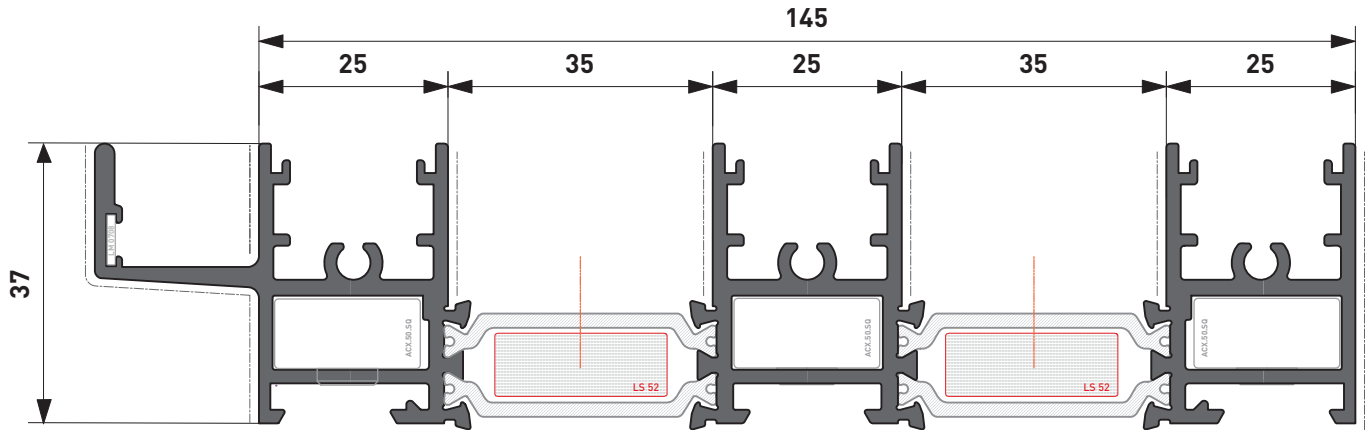

SX85.174

kg/ml 3,080

-- mm. 98.7

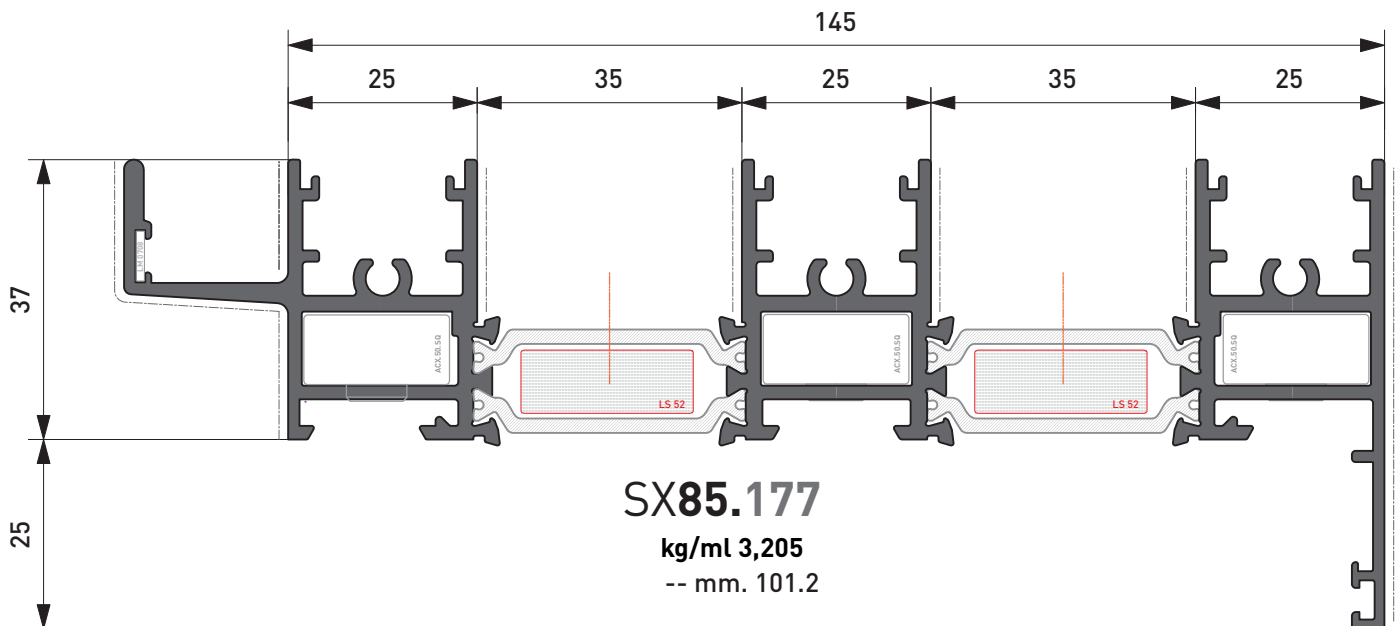

SX85.177

kg/ml 3,205

-- mm. 101.2

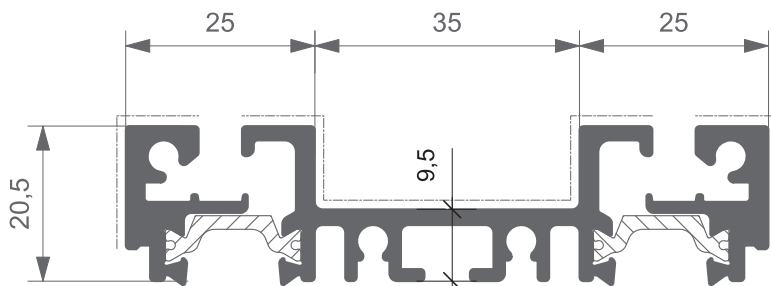

SX11.176

kg/ml 1,565

-- mm. 130,0

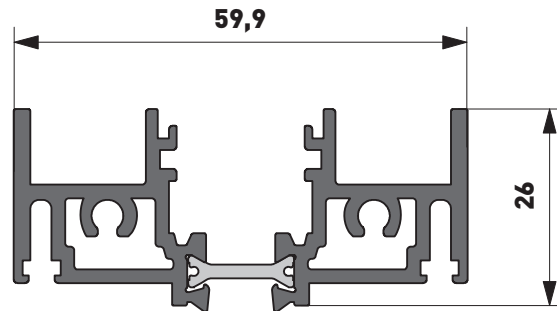

SX12.143

kg/ml 1,251

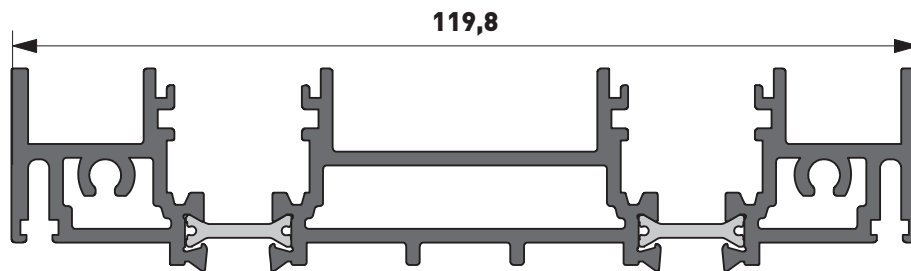

SX12.144

kg/ml 2,118

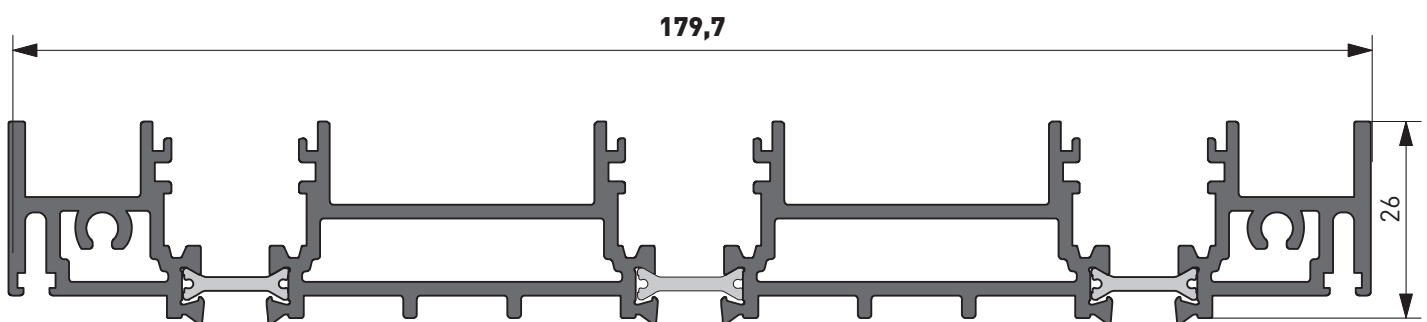

SX12.145

kg/ml 2,985

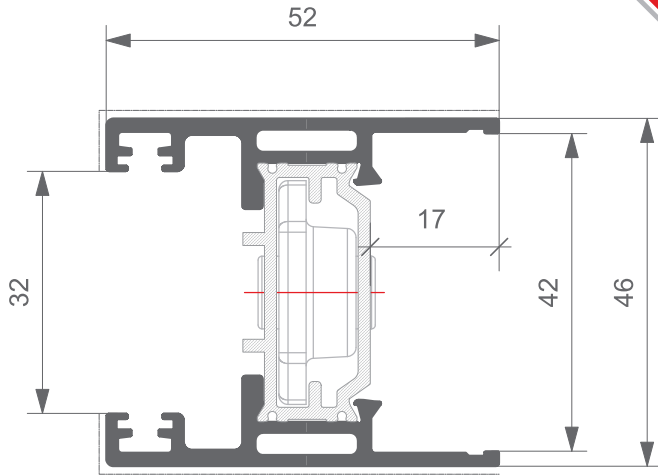

SX12.203

kg/ml 1,150
--- mm. 114,0

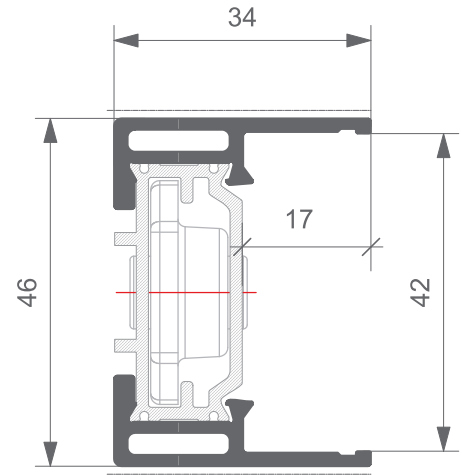

SX12.204

kg/ml 0,840
--- mm. 114,0

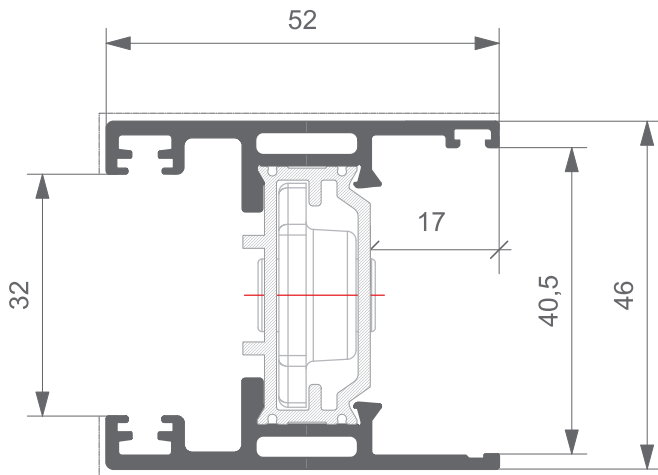

SX12.206

kg/ml 1,153
--- mm. 114,0

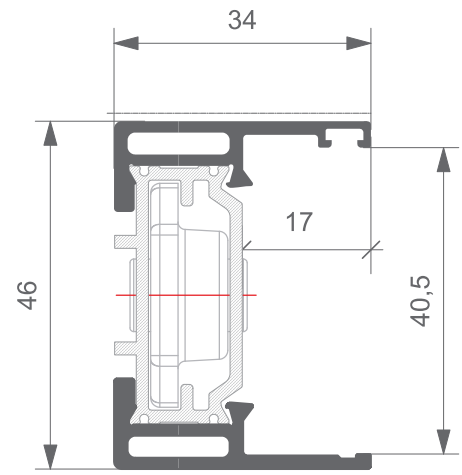

SX12.207

kg/ml 0,841
--- mm. 68,0

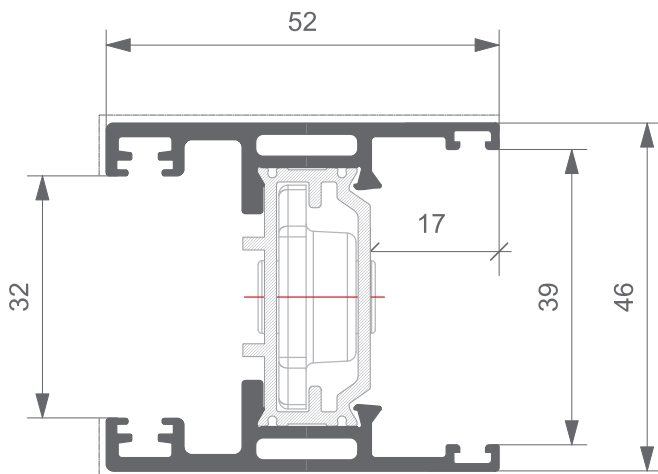

SX12.208

kg/ml 1,156
--- mm. 114,0

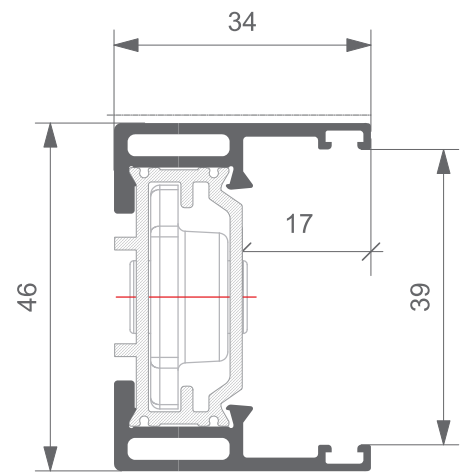

SX12.209

kg/ml 0,842
--- mm. 068,0

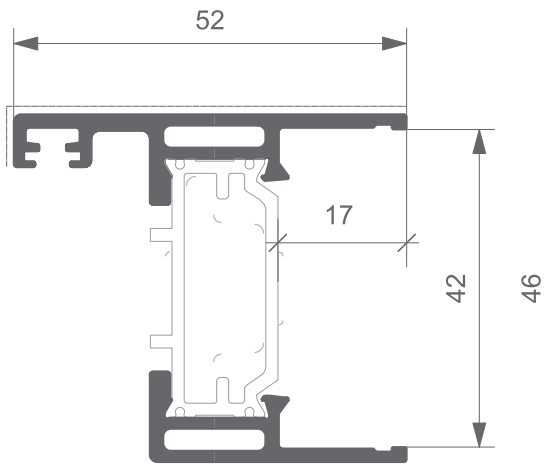

SX12.205

kg/ml 0,995

--- mm. 86,0

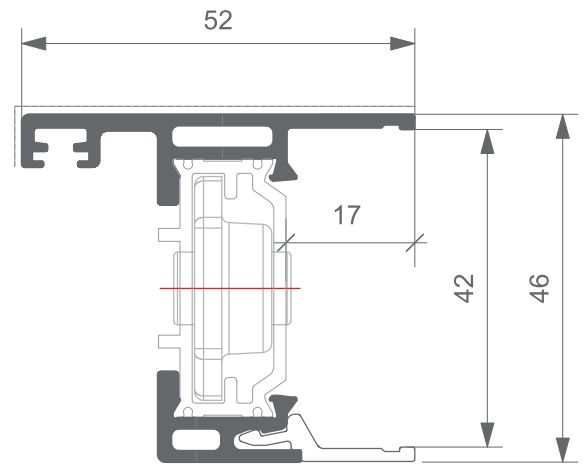

SX12.216

kg/ml 0,927

--- mm. 71,0

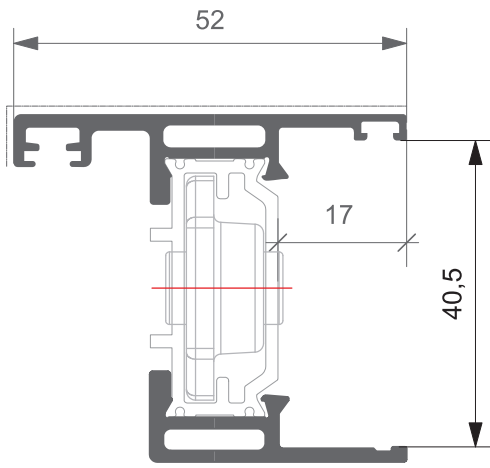

SX12.214

kg/ml 0,998

--- mm. 86,0

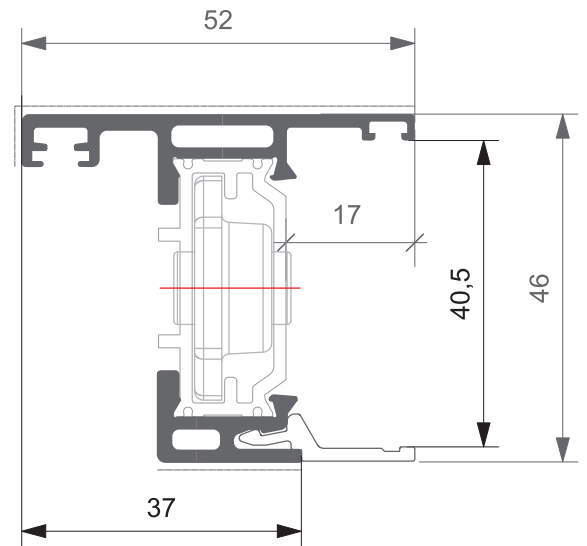

SX12.217

kg/ml 0,930

--- mm. 86,0

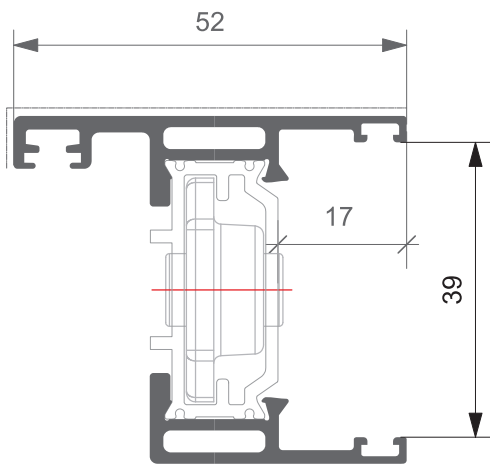

SX12.215

kg/ml 0,999

--- mm. 86,0

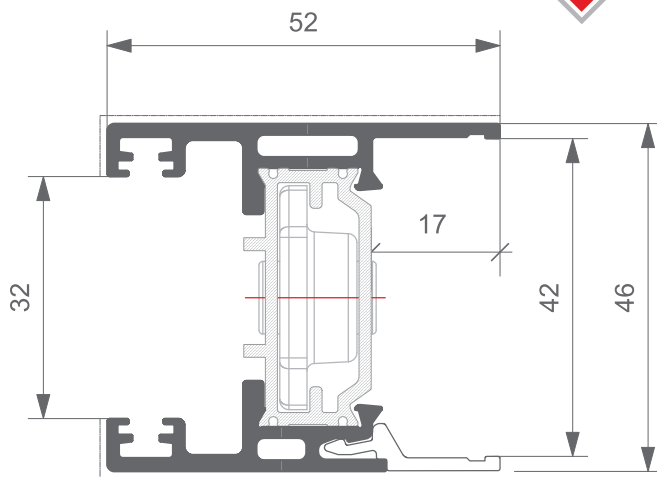

SX12.210

kg/ml 1,082

--- mm. 86,0

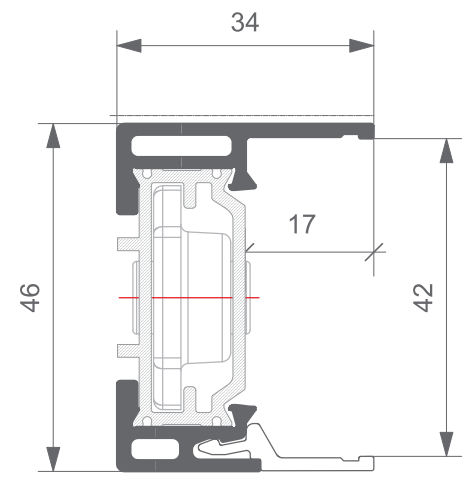

SX12.211

kg/ml 0,772

--- mm. 71,0

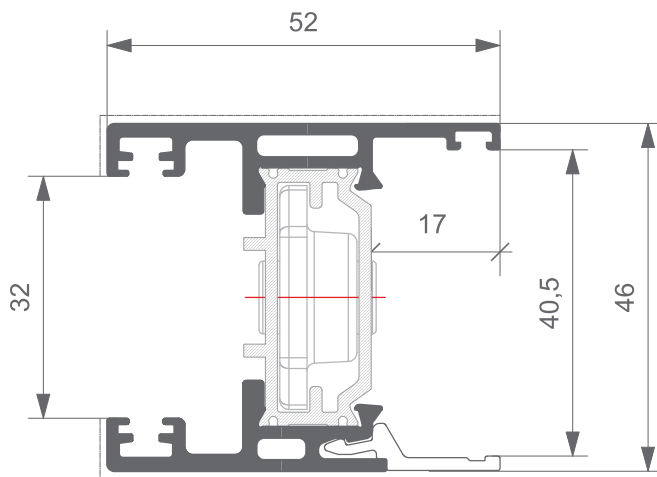

SX12.212

kg/ml 1,085

--- mm. 86,0

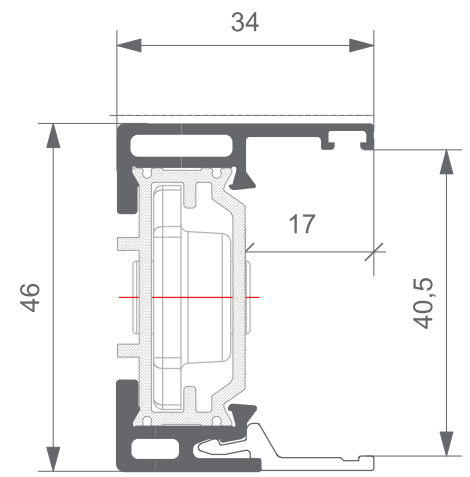

SX12.213

kg/ml 0,773

--- mm. 71,0

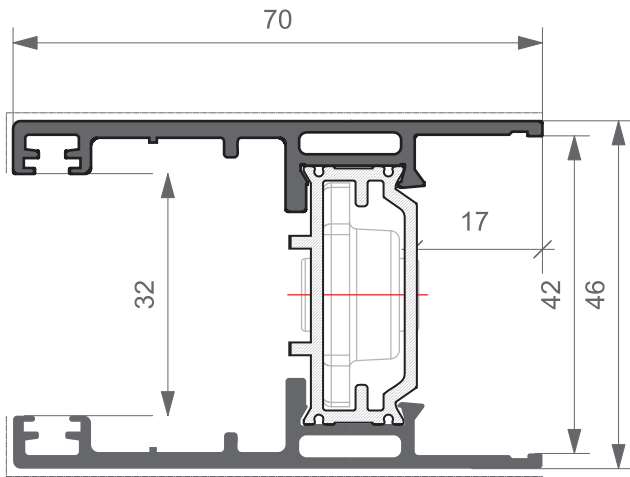

SX85.201

kg/ml 1,392

--- mm. 140,0

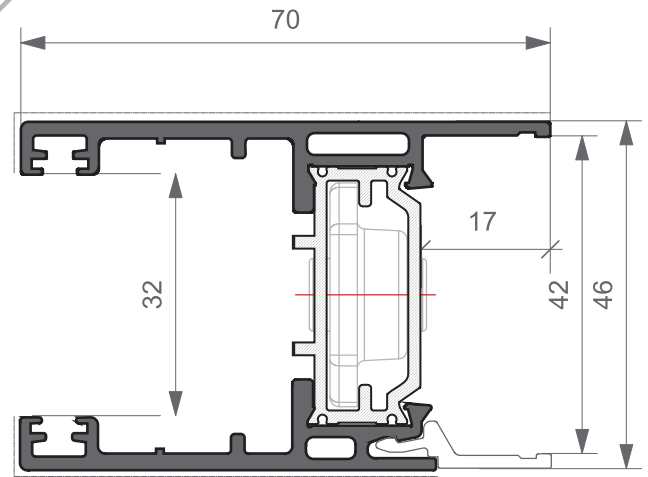

SX85.209

kg/ml 1,325

---mm. 115,0

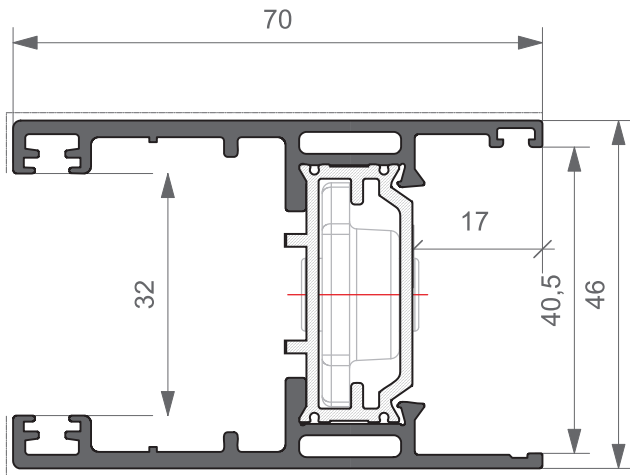

SX85.202

kg/ml 1,396

--- mm. 140,0

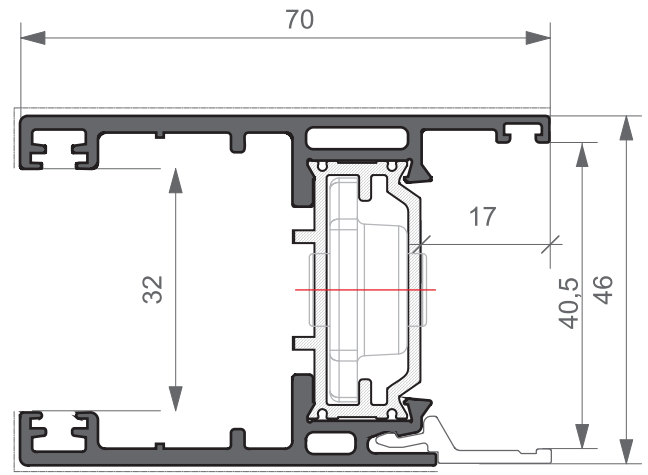

SX85.210

kg/ml 1,329

---mm. 115,0

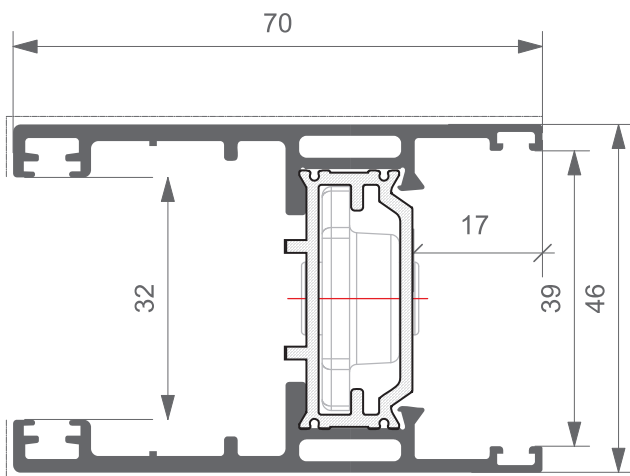

SX85.203

kg/ml 1,400

--- mm. 140,0

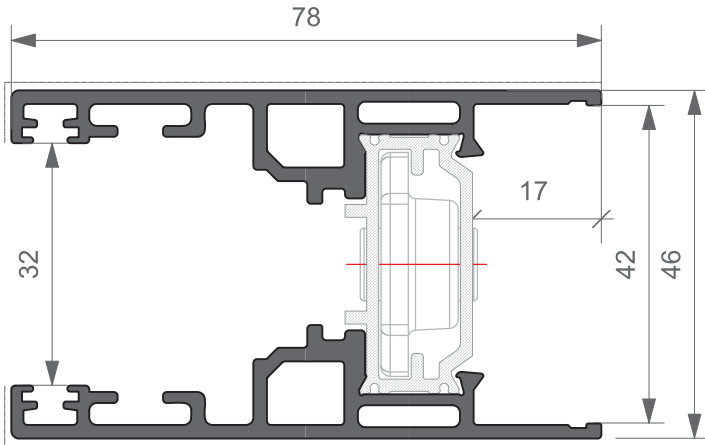

SX85.204

kg/ml 1,760

--- mm. 156,0

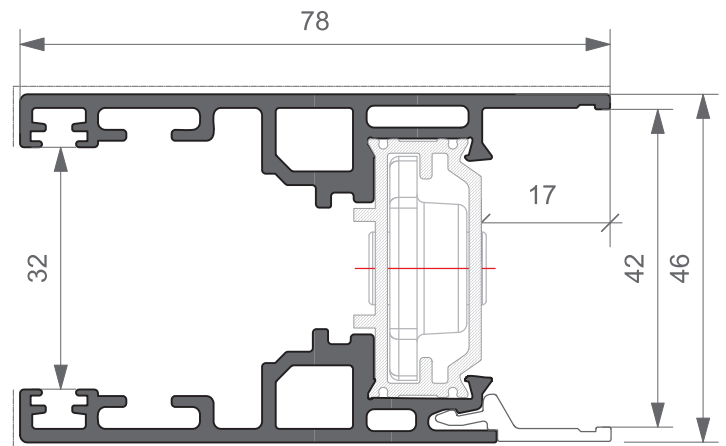

SX85.207

kg/ml 1,695

--- mm. 139,0

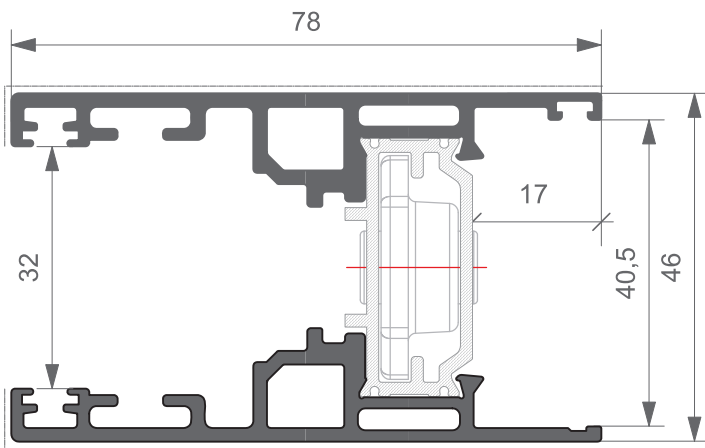

SX85.205

kg/ml 1,764

--- mm. 156,0
78

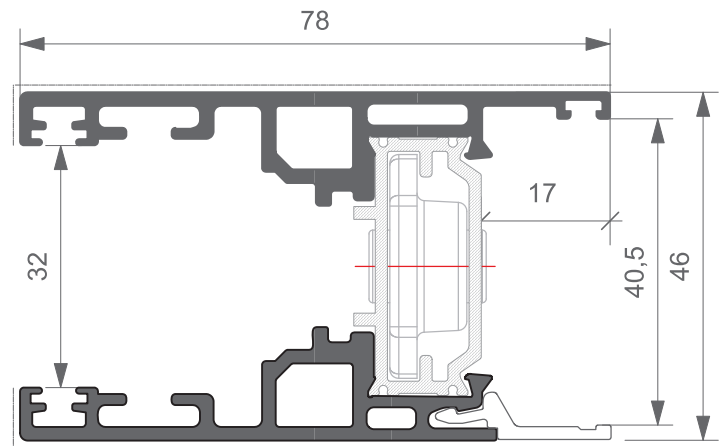

SX85.208

kg/ml 1,699

--- mm. 139,0

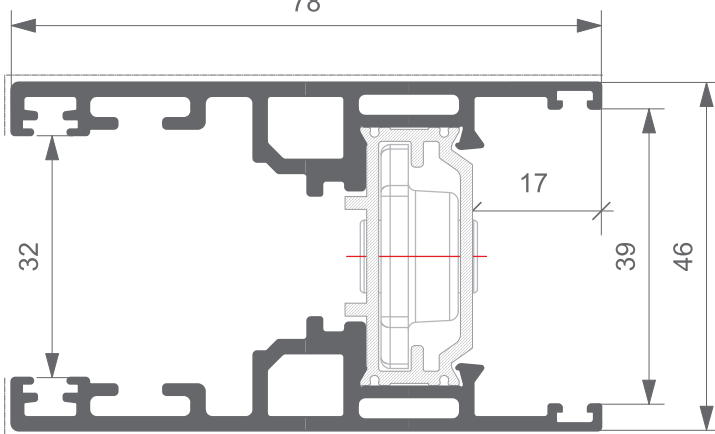

SX85.206

kg/ml 1,768

--- mm. 156,0

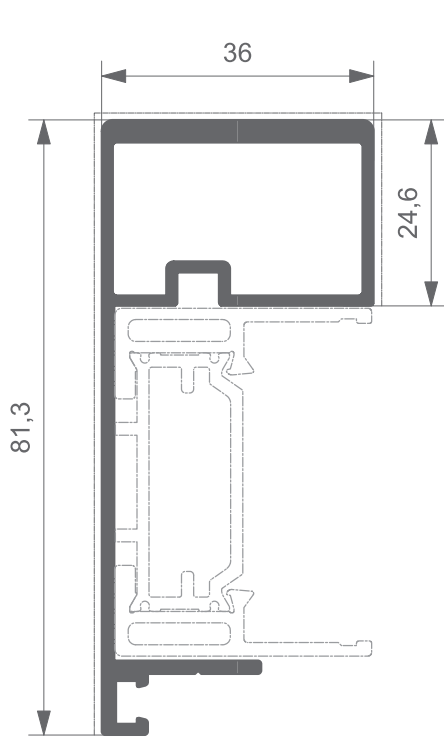

SX12.301
kg/ml 1,204
--- mm. 124,0

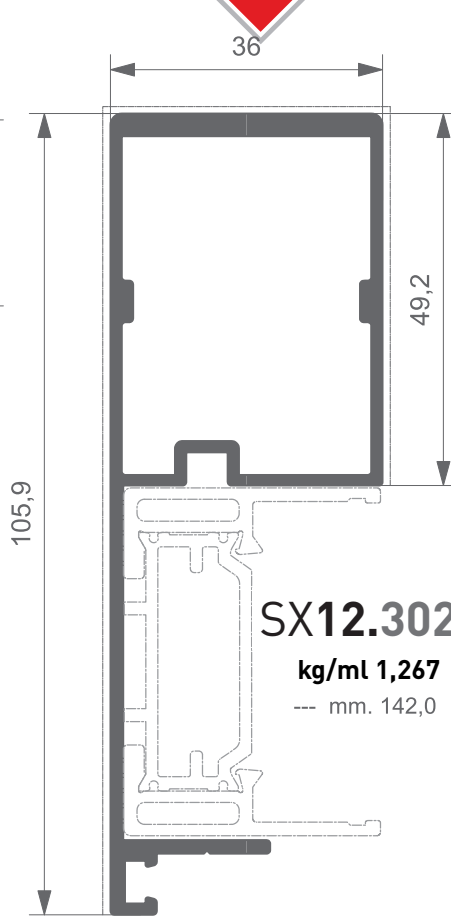

SX12.302
kg/ml 1,267
--- mm. 142,0

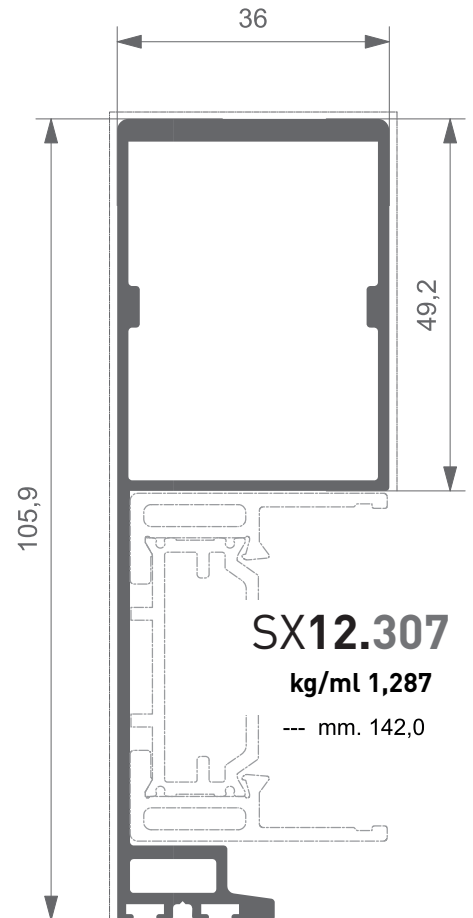

SX12.307
kg/ml 1,287
--- mm. 142,0

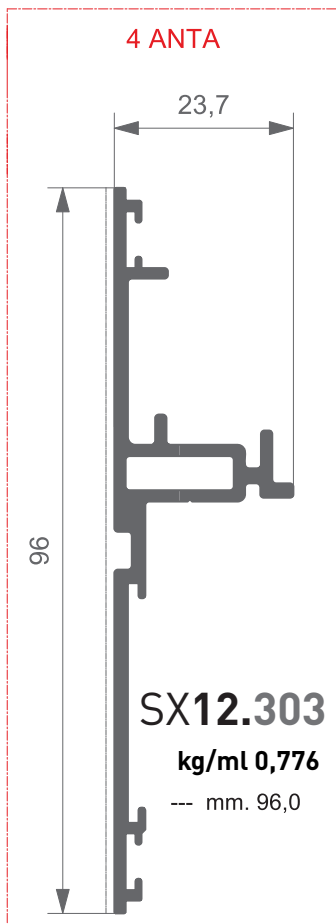

SX12.303
kg/ml 0,776
--- mm. 96,0

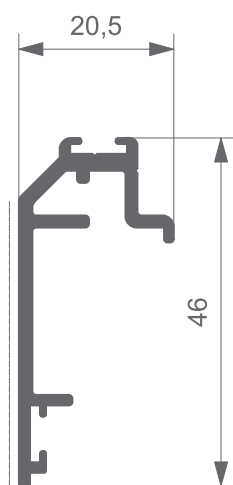

SX12.304
kg/ml 0,418
--- mm. 38,0

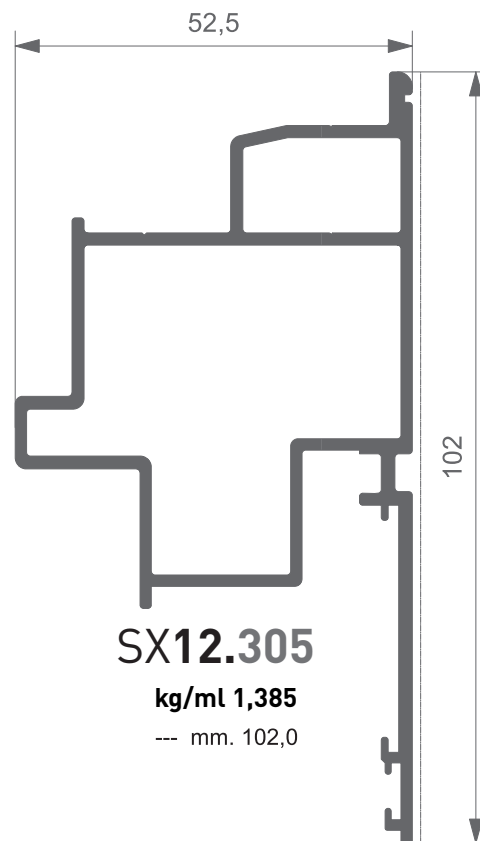

SX12.305
kg/ml 1,385
--- mm. 102,0

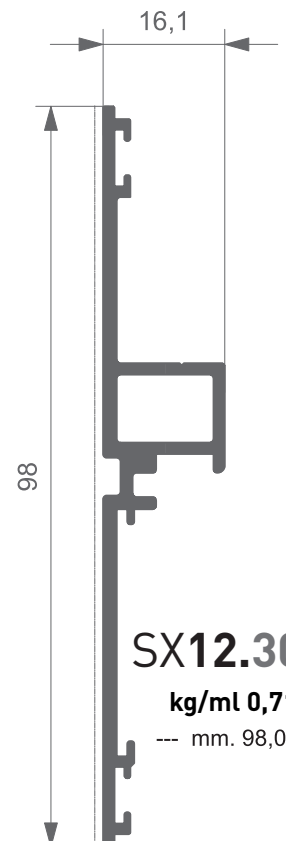

SX12.306
kg/ml 0,717
--- mm. 98,0

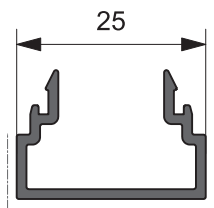

SX85.501

kg/ml 0,229
--- mm. 42,0



SX85.506

kg/ml 0,127
--- mm. 15,0

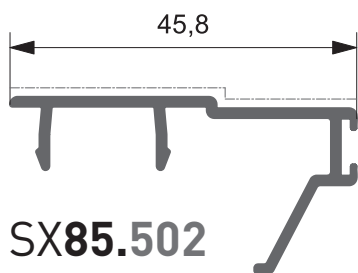

SX85.502

kg/ml 0,326
--- mm. 46,0



SX85.507

kg/ml 0,149
--- mm. 15,0

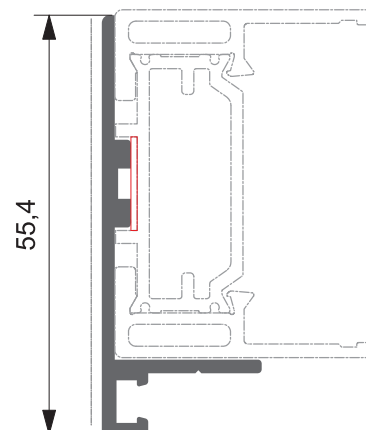

SX12.308

kg/ml 0,432
--- mm. 55,0

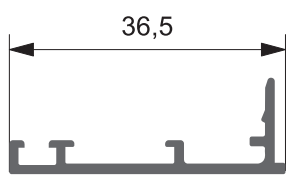

XX70.503

kg/ml 0,224
--- mm. 37,0

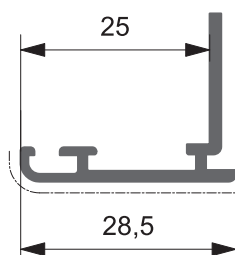

RC 029

kg/ml 0,222
--- mm. 32

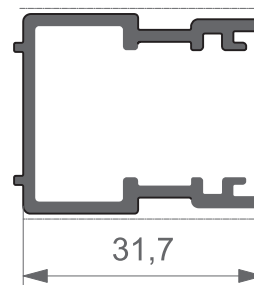

SX11.303

kg/ml 0,472
--- mm. 63,0

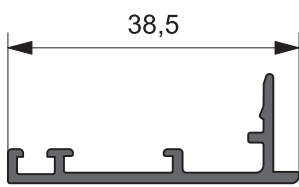

XX70.504

kg/ml 0,238
--- mm. 39,0

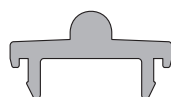

SX85.505

kg/ml 0,235
--- mm. 25,0

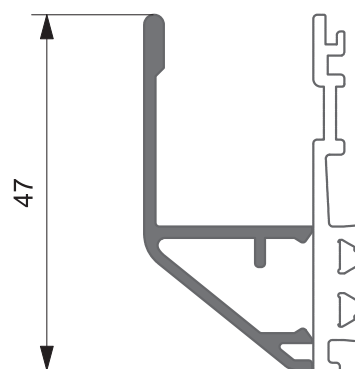

SX11.632

kg/ml 0,361
--- mm. 58,0



Accessori e Guarnizioni
Accessories and Gaskets

Gruppo C

Elenco accessori | *List of Accessories*
Elenco guarnizioni | *List of Window Gaskets*



CODIFICA FINITURE SUPERFICIALI ACCESSORI

ACCESSORIES SURFACE FINISHING CODES

In fase di ordine aggiungere agli accessori, se previste, le seguenti codifiche superficiali:
When ordering, add the following surface codes to the accessories listed below, where applicable:

<i>DESCRIPTION</i>	CODICE CODE	<i>DESCRIZIONE</i>
<i>PAINTED MATT BLACK</i>	NEOPA	VERNICIATO NERO OPACO
<i>WHITE</i>	R 9 0 1 0	VERNICIATO BIANCO
<i>IVORY</i>	R 1 0 1 3	VERNICIATO AVORIO
<i>GREEN</i>	R 6 0 0 5	VERNICIATO VERDE
<i>BLACK</i>	R 9 0 0 5	VERNICIATO NERO LUCIDO
<i>BROWN</i>	R 8 0 1 7	VERNICIATO MARRONE
<i>GOTHIC GREEN</i>	G 6 3 6 0	VERNICIATO VERDE GOTICO
<i>GOTHIC GREY</i>	G 9 4 2 0	VERNICIATO GRIGIO GOTICO
<i>GOTHIC BROWN</i>	G 3 9 7 6	VERNICIATO MARRONE GOTICO
<i>SILVER</i>	V E A R	VERNICIATO ARGENTO
<i>WITHERED MOSS</i>	V S C R A	VERDE SCURO RAGGRINZITO
<i>FALLOW</i>	M A R A G	MARRONE RAGGRINZITO
<i>GOLDFINISH GUNMETAL GRAY</i>	K A N F U	CANNA DI FUCILE GOLDFINISH
<i>GOLDFINISH COPPER</i>	K R A M E	RAME GOLDFINISH
<i>GOLDFINISH POLISHED</i>	K I N O X	INOX LUCIDO GOLDFINISH
<i>GOLDFINISH SATIN-FINISH STAINLESS STEEL</i>	K S A T I	INOX SATINATO GOLDFINISH
<i>GOLDFINISH GOLD</i>	K G O L D	GOLD GOLDFINISH
<i>GOLDFINISH ANTIQUE BRASS</i>	K A N T I C	OTTONE ANTICO GOLDFINISH
<i>NEW SILVER</i>	A R G E N T	NEW ARGENTO
<i>NEW BRONZE</i>	B R O N Z	NEW BRONZO













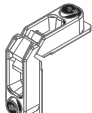



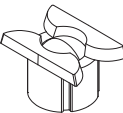



ESEMPIO

ACX 08.71 | R 9010



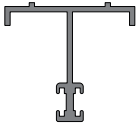

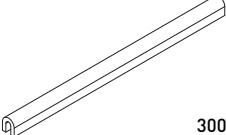





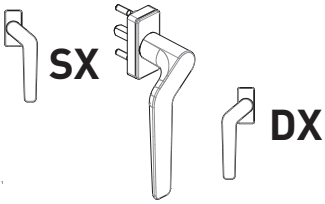
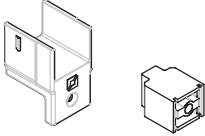
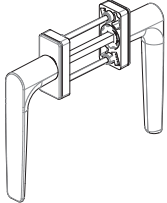
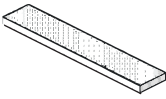

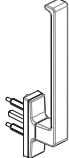
Martellina Verniciata | COLORE Bianco Ral 9010
Painted Handle | COLOUR White RAL 9010

EXAMPLE

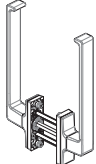

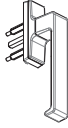
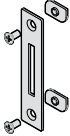
<p>ACX.50.SQ</p> <p>Descrizione Description Squadretta a pulsante per telaio Push-button bracket for frame</p>	 <p>SX85.101 SX85.102 SX85.103 SX85.104 SX85.105</p>	<p>ASX.10.34</p> <p>Descrizione Description Spazzolino base 6.9 mm. con tripla pinna Base toothbrush 6.9 mm. with triple fin</p> 	
<p>AWX.16.SQ</p> <p>Descrizione Description Squadretta a pulsante per telaio Push-button bracket for frame</p>	 <p>SX12.153</p>	<p>ASX.10.69</p> <p>Descrizione Description Guarnizione di tenuta per anta Sealing gasket for Sash</p> 	
<p>AMX.6841</p> <p>Descrizione Description Boccole di drenaggio in plastica Plastic rain bushings</p>	 <p>d=12 mm</p>	<p>ACX.10.71</p> <p>Descrizione Description Guarnizione per fermavetro. Gasket for glazing beads.</p>  <p>Si consiglia di usare a pezzi It is recommended to use in pieces</p>	
<p>ASX.05.02</p> <p>Boccole di drenaggio con sfera in plastica Drain bushings with plastic ball</p>	<p>Ø12 x H5.5 mm.</p> 	<p>ASX.10.72</p> <p>Descrizione Description Guarnizione profilo centrale Central profile gasket</p> 	
<p>AMX.6841.3</p> <p>Ø7.5 x H12 mm.</p>		<p>ASX.10.74</p> <p>Descrizione Description Guarnizione per vetro da inserire mm.32 Gasket for glass to inserted mm. 32</p>  <p>+/- 1 mm. dello spazio vetro</p>	
<p>ARX.06.01</p> <p>Descrizione Description Registro telaio universale in zama Universal frame adjuster in zamak</p>		<p>ASX.10.80</p> <p>Descrizione Description Guarnizione per vetro da inserire mm.28 Gasket for glass to inserted mm.28</p>  <p>+/- 1 mm. dello spazio vetro</p>	
<p>ARX.10.12</p> <p>Descrizione Description Guarnizione vetro interna Internal glass gasket</p>	 <p>spessore thickness 3 - 4 mm.</p>	<p>BX09</p> <p>Descrizione Description Barretta guida inferiore per binario Inox Lower guide bar for stainless steel rail</p> 	
<p>ARX.10.13</p> <p>Descrizione Description Guarnizione vetro interna Internal glass gasket</p>	 <p>spessore thickness 5 - 6 mm.</p>	<p>BX30</p> <p>Descrizione Description Profilo isolante per ferramenta Insulating profile for hardware</p> 	
<p>ARX.10.14</p> <p>Descrizione Description Guarnizione vetro interna Internal glass gasket</p>	 <p>spessore thickness 7 - 8 mm.</p>	<p>BX53</p> <p>Barretta Traverso Superiore SX85.502 Insulating Profile for Upper Transom SX85.502</p> 	
<p>ASX.10.26</p> <p>Descrizione Description Barretta coprirotaia Rail cover bar</p>		<p>ASX.15.02</p> <p>Descrizione Description Binario ad "U" in acciaio inox "U" track in stainless steel</p>  <p>3000 mm.</p>	
<p>ARX.10.15</p> <p>Descrizione Description Guarnizione vetro interna Internal glass gasket</p>	 <p>spessore thickness 9 - 10 mm.</p>	<p>ASX.10.33</p> <p>Descrizione Description Guarnizione lunga esterna vetro Long outer glass gasket</p>  <p>mm. 1,5</p>	

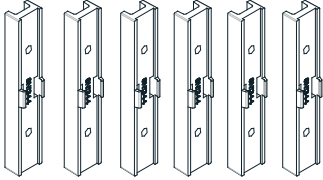
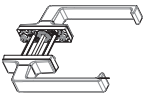

<p>ASX.15.04</p> <p>Descrizione Description Maniglia ad incasso - Scasso alloggiamento 187x19mm Embedded Handle Housing Hole 187x19 mm.</p>		<p>ACX.08.71 SX -DX</p> <p>Descrizione Description Martellina "KARMA" DX/SX c/manico disassato L quadro 26mm Martellina Handle "KARMA" RH/LH w/Offset Panel Projection 26 mm.</p>	
<p>ASX.07.10</p> <p>Descrizione Description KIT Tappo 4^ Anta per Alzante Scorrevole 4th Sash Cap Kit for LIFT & SLIDE</p>		<p>ACX.08.72</p> <p>Descrizione Description Doppia Martellina "KARMA" per sez. profilo fino a 64 mm Two-Side Martellina "KARMA" for Profile Sect. up to 64 mm.</p>	
<p>ASX.15.15</p> <p>SX11.176 Descrizione Description Tassello di tenuta centrale c/Spazzolino Block w/Center Seal and Brush</p>		<p>ASX.08.73</p> <p>Descrizione Description Maniglia di traino esterna External Pull Washer</p>	
<p>ASX.16.20</p> <p>Descrizione Description Martellina "ITALIA" 7mm Handle "ITALY" 7mm</p>		<p>ASX.08.74</p> <p>Descrizione Description Maniglia ad incasso Sporgenza Quadro 21.5 mm. Embedded Handle Square Projection 21.5 mm.</p>	
<p>ASX.16.21</p> <p>Descrizione Description Copri-cilindro serratura "ITALIA". Lock cylinder cover "ITALIA"</p>		<p>ASX.08.75</p> <p>Descrizione Description Maniglia ad incasso versione Automatica Lavorazione 187x 20 mm. Automatic Embedded Handle Housing Hole 187x20 mm.</p>	
<p>ASX.16.22</p> <p>Descrizione Description Martellina doppia "ITALIA" 7mm Double handle "ITALY" 7mm</p>		<p>ASX.08.76</p> <p>Descrizione Description Nasello in acciaio a T zigr. c/Piega 10mm. T Steel Hook w/10mm. Bend</p>	
<p>ACX.08.42</p> <p>Descrizione Description Martellina "ITALIA" Martellina Handle "ITALY" Interasse/center dist. 43mm</p>		<p>ASX.08.78</p> <p>Descrizione Description Riscontro c/ Eccentrici CounterPlate w/Offset pins</p>	
<p>ACX.08.60</p> <p>Descrizione Description Martellina "KARMA" sporgenza quadro 26 mm. Martellina Handle "KARMA" Panel Project. 26 mm.</p>		<p>ASX.08.80</p> <p>Descrizione Description Cover sagomata per Fastlock Molded Cover for Fastlock.</p>	
<p>ACX.04.63</p> <p>Descrizione Description Clip per profili XX70.503-504 Profile clip XX70.503-504</p>		<p>ASX.08.82</p> <p>Descrizione Description KIT Basetta per contropiastra anta minimale KIT Baseplate for minimal sash counterplate Qt. 6 pz./pc.</p>	
<p>ACX.03.69</p> <p>Descrizione Description Martellina Doppia "ITALIA" Double Handle "ITALIA" Interasse/center dist. 43mm</p>			



<p>ASX08.77</p> <p>Descrizione Description</p> <p>Giunzione ANGOLARE INFERIORE LOWER CORNER Junction</p>	
--	--

<p>ASX.6742.18</p> <p>Descrizione Description</p> <p>Sostegno Anta Fissa Maggiorata Fixed Over Sized Sash Support</p>	
---	--

<p>LS 01</p> <p>Descrizione Description</p> <p>Listello Isolante Insulating Shim</p> <p>Dim. 15 x 11 mm.</p>	
--	--

<p>ASX.12.6N0835</p> <p>Kit tappi per profilo SX12.302 e similari Kit caps for profile SX12.302 and similar</p>	
--	--

<p>LS 52</p> <p>Descrizione Description</p> <p>Listello Isolante Insulating Shim</p> <p>Dim. 22 x 8 mm.</p>	
---	--

<p>ASX85.CAR.ALZ</p> <p>Descrizione Description</p> <p>Coppia Carrelli Anta SX85.204 vers. Alzante Pair of Carriers for Lifting Sash SX85.204</p>	
---	--



Esploso Exploded View

Kit Mobile + Mobile - 240 Kg anta 2
Sliding Sashes kit - 240 Kg Sash

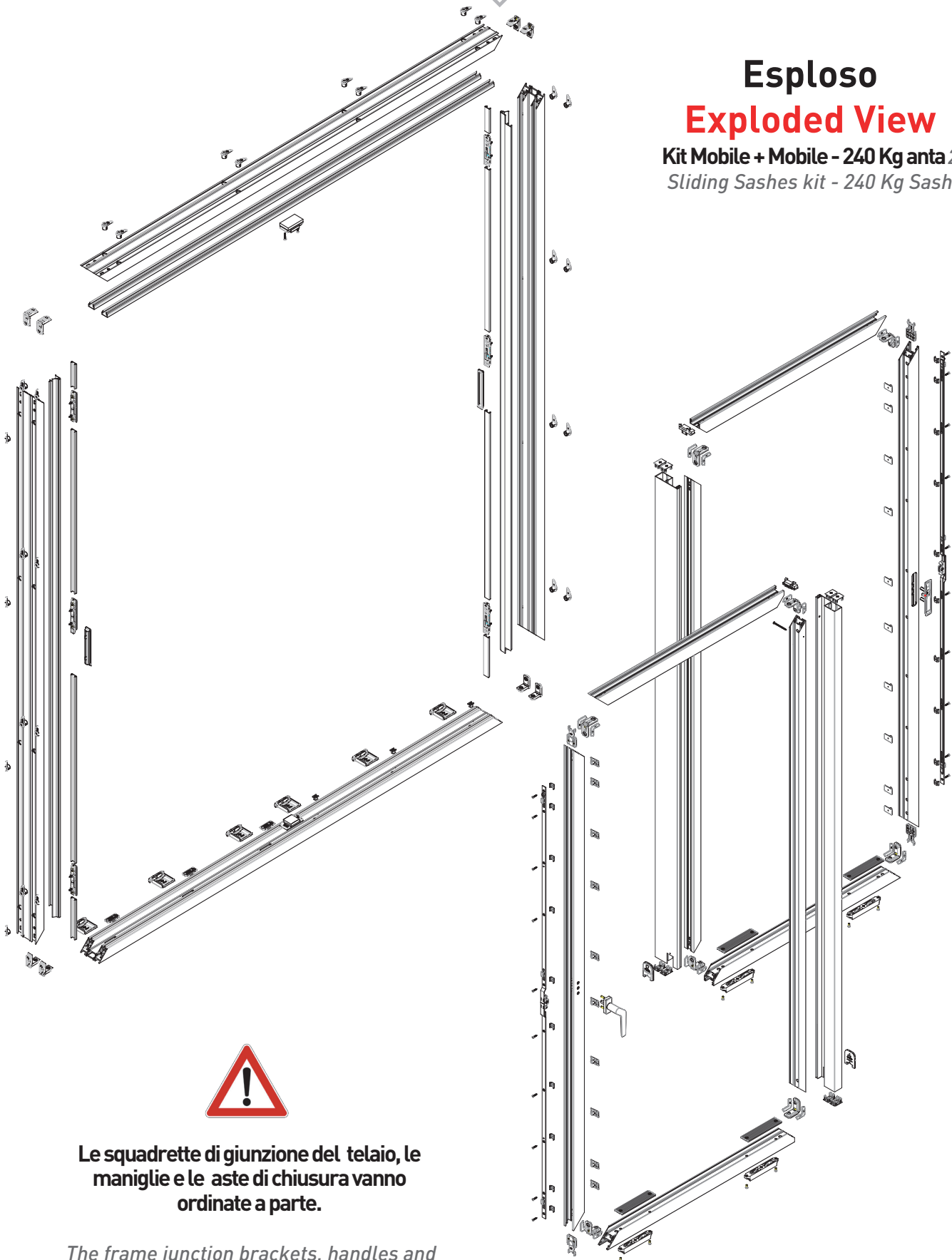

Le squadrette di giunzione del telaio, le maniglie e le aste di chiusura vanno ordinate a parte.

The frame junction brackets, handles and closing rods must be ordered separately.

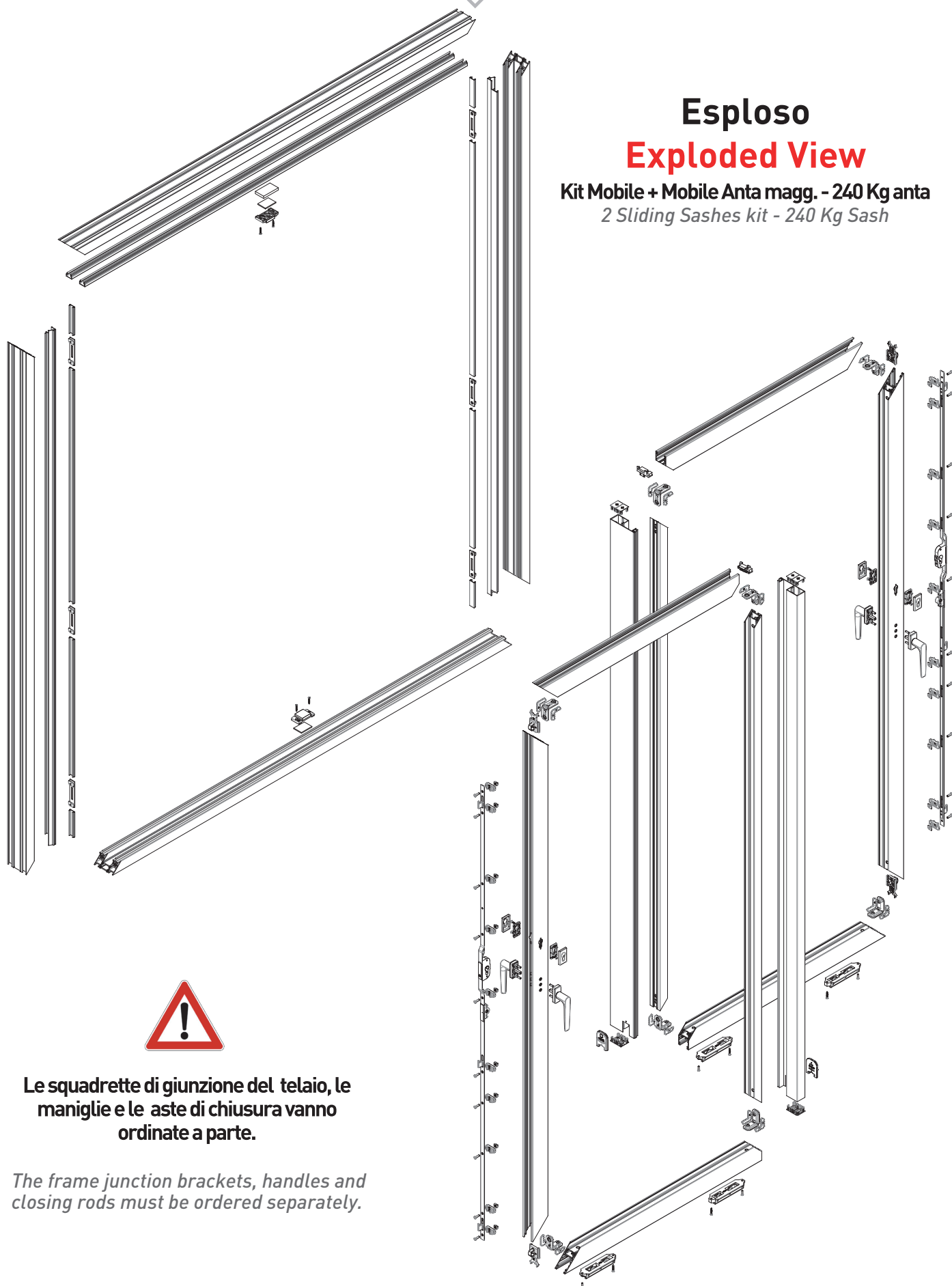

Esploso

Exploded View

Kit Mobile + Mobile Anta magg. - 240 Kg anta
2 Sliding Sashes kit - 240 Kg Sash



Le squadrette di giunzione del telaio, le maniglie e le aste di chiusura vanno ordinate a parte.

The frame junction brackets, handles and closing rods must be ordered separately.



ASX.12.K1AM

Kit mono anta a scomparsa - 240 Kg anta
Single Retractable door kit - 240 Kg Sash

SX12.203....

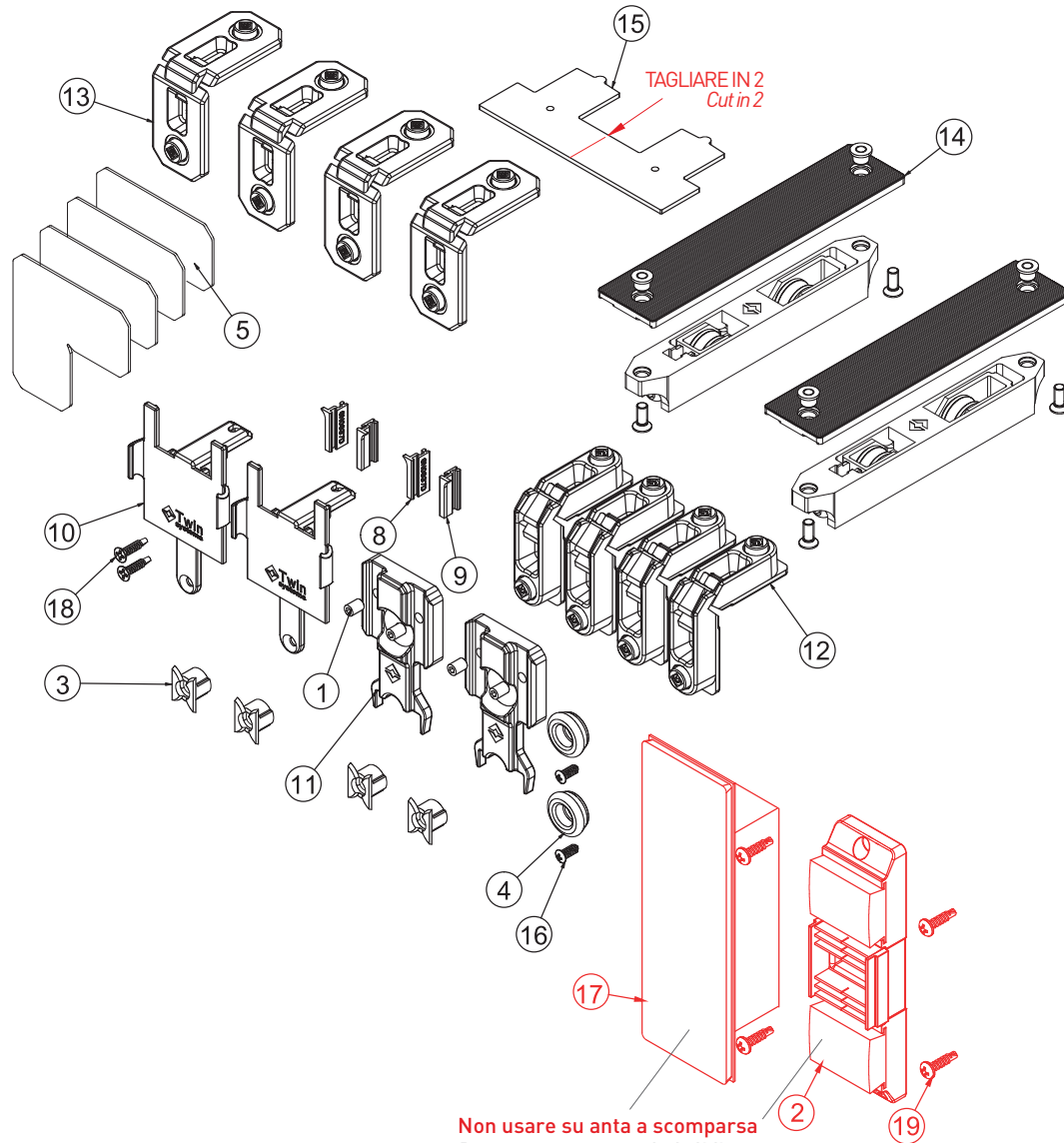

Non usare su anta a scomparsa
Do not use on concealed sliding

N.	Descrizione Description	Qt.
1	Grano M 5x7 punta coppa (Rif. UNI5929 DN 916) Grain M 5x7 cup Tip	4
2	Tassello di tenuta centrale Central sealing piece	1
3	Boccola di Drenaggio Ø12-SV9-NE BC Drain Washer Ø12-SV9-NE BC	4
4	Tassello ammortizzatore in bimateriale Shock absorber in bi-material	2
5	Squadretta allineamento per profilo SX.12.153 Alignment corner joint for SX.12.153 profile	4
8	Tappino DX cartella SX120 Right cap SX120 folder	2
9	Tappino SX cartella SX120 Left cap SX120 folder	2
10	Base tassello anti scarrucolamento superiore (Centr.-Lat.) Upper anti-derailing dowel base (Center-Lat.)	2

N.	Descrizione Description	Qt.
11	Tassello ammortizzatore (anti scarr. Inferiore-Superiore) Shock absorber /anti-derail plug (Lower-Upper)	2
12	Squad. Pressofusa da 16,8x14,3 mm. Die-cast corner joint 16.8x14.3 mm.	4
13	Squad. da 30x10 a doppio pulsante Corner Joint from 30x10 with double button	4
14	Carrello SX120-240 Kg Arrotondato SX 120 - 240 Kg Rounded Trolley	2
15	Guarnizione fustellata biadesiva per taglio 90° Double-sided adhesive punched gasket for 90° cut	1
16	Vite autofilettante TCCR 3,9x9,5 Testa Ribassata Self-tapping screw TCCR 3.9x9.5 Lowered Head	2
17	Tassello tenuta centrale superiore da 49 mm. 49 mm upper central sealing gusset.	1
18	TSPCR 3,5x16 mm. Autoforanti TSPCR 3.5x16 mm. Self-drilling	2
19	Vite Autoforante Self-drilling screw	2
21	Coprisola Scarico Acqua Water drainage slot cover	2



ASX.85.K2AM

Kit Mobile + Mobile - 240 Kg anta
Sliding Sashes kit - 240 Kg Sash
[SX12.203/06/08/10/12]

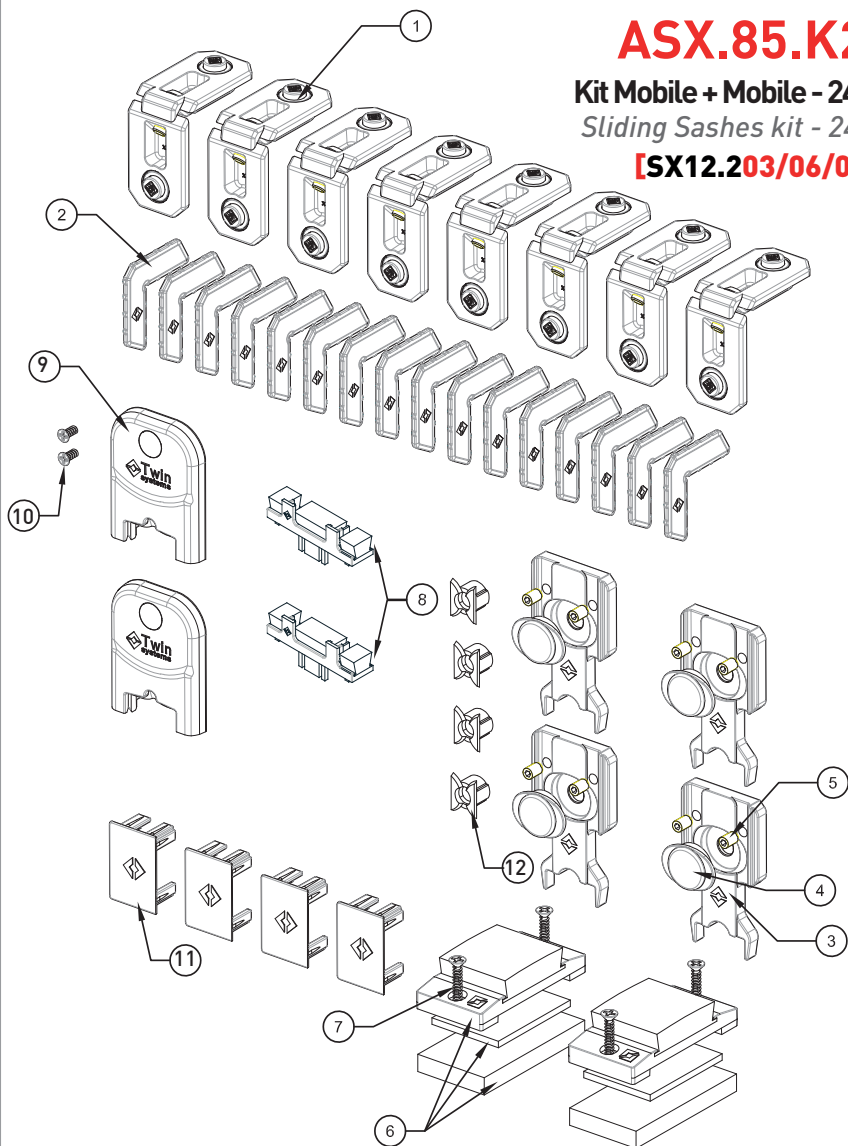

ASX 85.CAR*

Coppia carrello Bilanciato Registrabile
240 Kg./Anta
Balanced Adjustable Roller
240 Kg./Anta

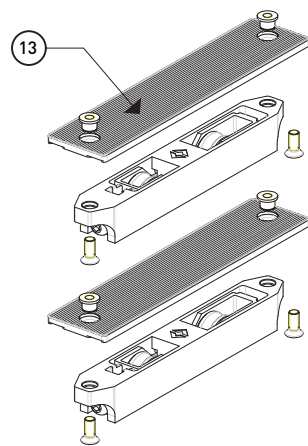
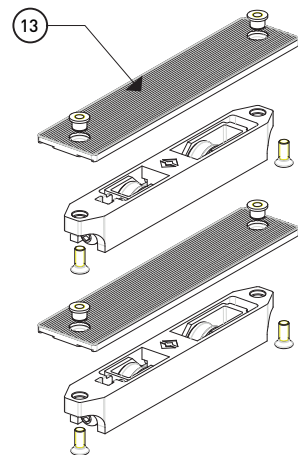

***ASX 85.CAR.N**

***Variante 1: Coppia Carrello Bilanciato Registrabile 180kg./anta c/Ruota NYLON per Binario SX85.505**
**Variant 1: Pair of Adjustable Balanced Trolley 180kg./Sash with NYLON Wheel for SX85.505 Track*



***ASX 85.CAR.NE**

***Variante 2: Coppia Carrello Registrabile **90kg./anta c/Ruota Singola NYLON per Binario SX85.505**
**Variant 2: Pair of Adjustable Trolley **90kg./Sash with Single NYLON Wheel for SX85.505 Track*
****Per portate superiori vedere tavola "G10" / **For higher load capacities, check page "G10"**

N.	Descrizione Description	Qt.
1	Squad. da 30x10 a doppio pulsante Corner Joint from 30X10 w/ double Button	8
2	Squad. allineamento per profilo anta Alignment Corner Joint for Sash Profile	16
3	Tassello ammortizzatore/anti scarr. (Inferiore-Superiore) Shock Absorber/Anti Derail Plug (Upper/Bottom)	4
4	Tassello ammortizzatore in gomma Rubber Shock Absorber Plug	4
5	Grano M5x7 punta coppa (Rif. UNI 5929 DIN 916) Grain M5x7 tip cup (Ref. UNI 5929 DIN 916)	8
6	Tassello tenuta centrale inferiore Upper/Lower Central Sealing Plug	2
7	Vite autoforante TSPCR 3.9x25 inox Self Drillig Screw TSPCR 3.9X25 INOX	4
8	Tappo coprilavorazione SX85-sup. SX 85 Upper Central Profile Finishing Plug	2
9	Tappo coprilavorazione SX85-120 SX 85 Lower Central Profile Finishing Plug	2

N.	Descrizione Description	Qt.
10	Vite autofilettante TSPCR 3,5x8 filetto UNI 6947 Self-tapping screw TSPCR 3,5x8 thread UNI 6947	4
11	Tappo copri tubolarità di rinforzo centrale SX85-120 SX 85/SX120 Central Profile Finishing Plug	4
12	Boccola di drenaggio Ø12-SV9-NE BC Drainage bush	4
13	Carrello SX85-SX120 -240 Kg Arrotondato SX85-SX120 - 240 Kg Rounded Trolley	2 cp.



ASX.85.K3AM

Kit aggiuntivo 3^a anta - 240Kg anta
Additional Kit 3rd sash - 240 Kg Sash

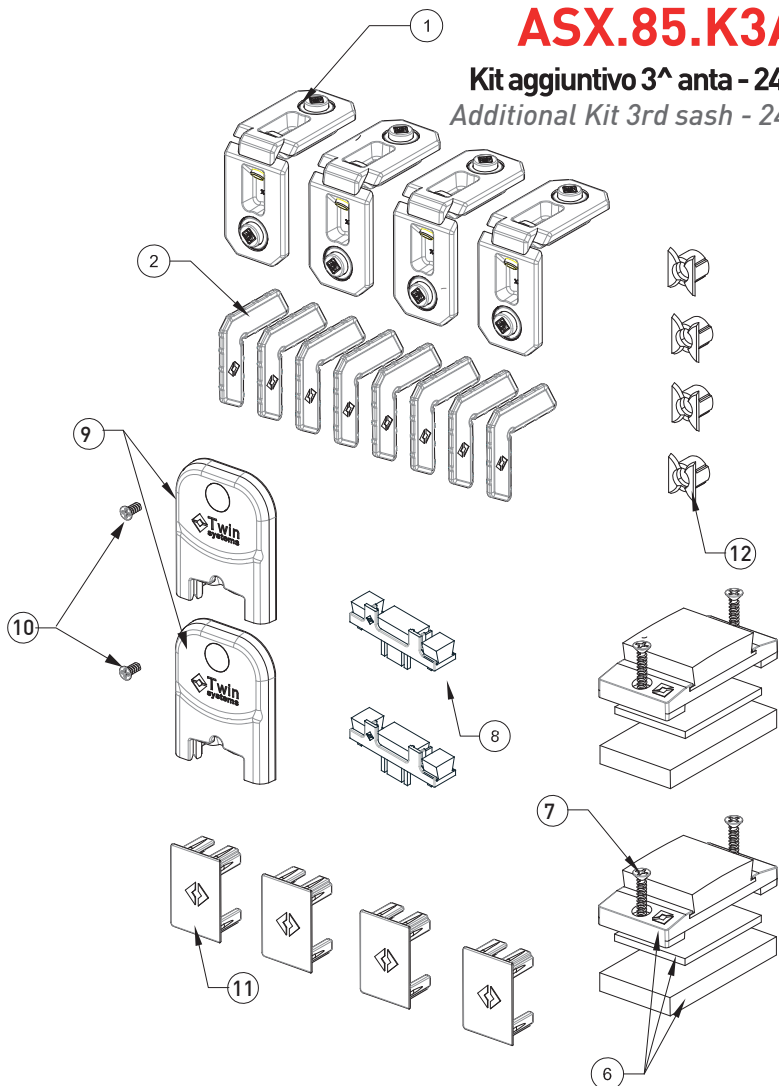

ASX 85.CAR*

[SX12.203/06/08/10/12]
Coppia Carr. Bilanciato Registr. 240 Kg./Anta
Balanced Adjustable Roller 240 Kg./Sash

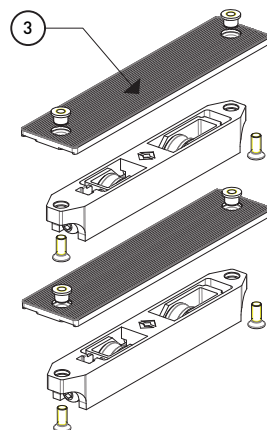

ASX 85.CARMAG

[SX85.201/02/03/09/10]
Coppia Carr. Bilanciato Registr. 240 Kg./Anta
Balanced Adjustable Roller 240 Kg./Sash

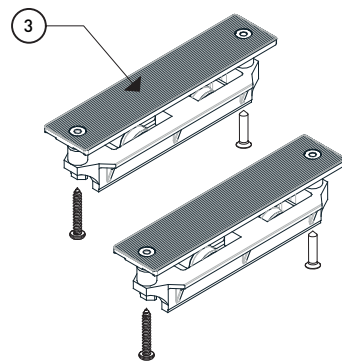

***ASX 85.CAR.N**

*Variante 1: Coppia Carrello Bilanciato Registrabile 180kg./anta c/Ruota NYLON per Binario SX85.505
*Variant 1: Pair of Adjustable Balanced Trolley 180kg./Sash with NYLON Wheel for SX85.505 Track



***ASX 85.CAR.NE**

*Variante 2: Coppia Carrello Registrabile **90kg./anta c/Ruota Singola NYLON per Binario SX85.505
*Variant 2: Pair of Adjustable Trolley **90kg./Sash with Single NYLON Wheel for SX85.505 Track
**Per portate superiori vedere tavola "G10" / **For higher load capacities, check page "G10"

N.	Descrizione Description	Qt.
1	Squad. da 30x10 a doppio pulsante Corner joint from 30x10 with double button	4
2	Squad. allineamento per profilo anta Alignment Corner joint for sash profile	8
6	Tassello tenuta centrale superiore e inferiore Upper and lower central sealing gusset.	2
7	Vite autoforante TSPCR 3.9x25 inox Self-drilling screw TSPCR 3.9x25 inox	4
8	Tappo coprilavorazione SX85-sup. Dx. Processing cap SX85	2
9	Tappo coprilavorazione SX85-sup. Sx. Processing cap SX85	2
10	Tappo coprilavorazione SX85-120 Processing cap SX85-120	1
11	Vite autofilettante TSPCR 3,5x8 filetto UNI 6947 Self-tapping screw TSPCR 3,5x8 thread UNI 6947	3
12	Tappo copri tubolarità di rinforzo centrale SX85-120 SX85-120 central reinforcement tubular cap	4
13	Boccola di drenaggio Ø12-SV9-NE BC Drainage bush	4

N.	Descrizione Description	Qt.
14	Carrello SX85-SX120 -240 Kg Arrotondato SX85-SX120 - 240 Kg Rounded Trolley	1 cp.



ASX.85.K2AMG

Kit Mobile + Mobile Anta magg. - 240 Kg anta
2 Sliding Sashes kit - 240 Kg Sash

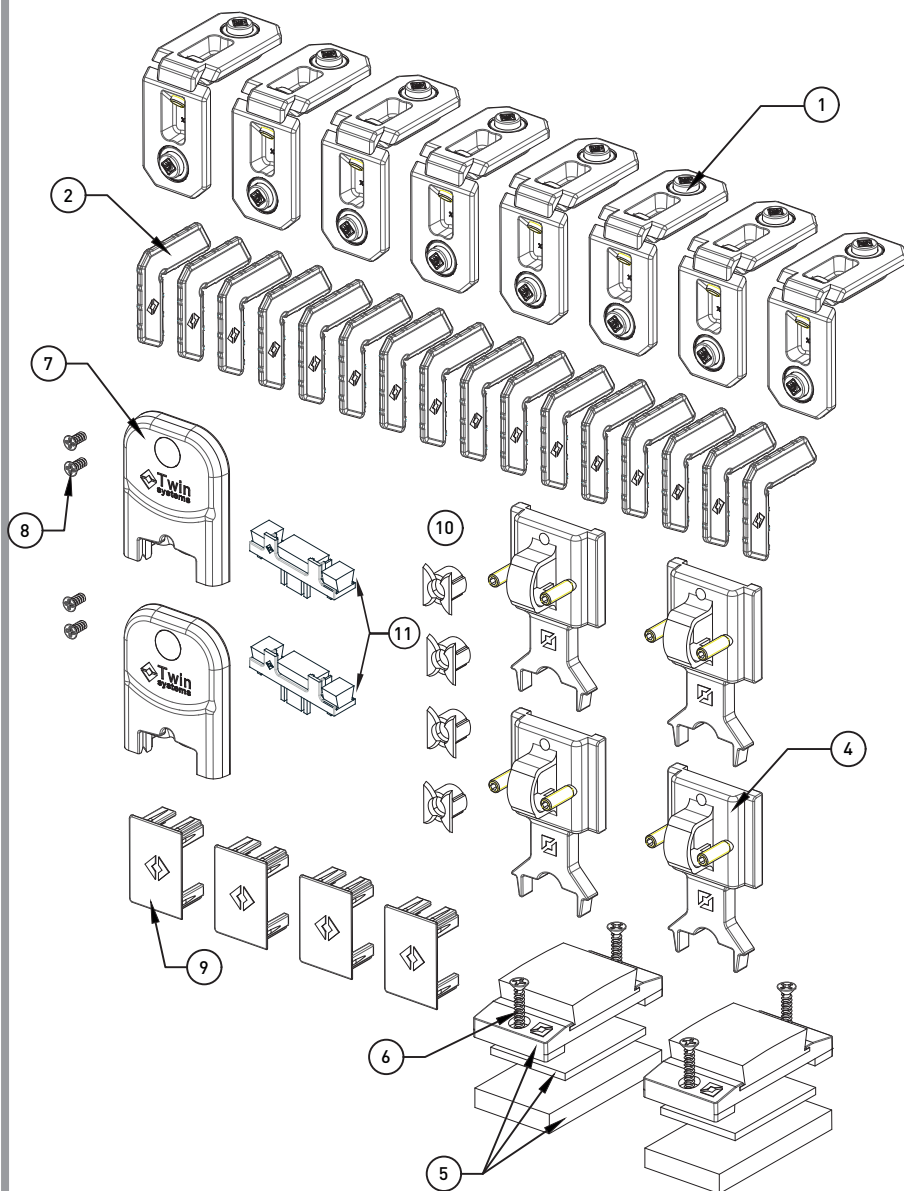

ASX 85.CARMAG

[SX85.201/02/03/09/10]
Coppia Carr. Bilanciato Registr. 240 Kg./Anta
Balanced Adjustable Roller 240 Kg./Sash

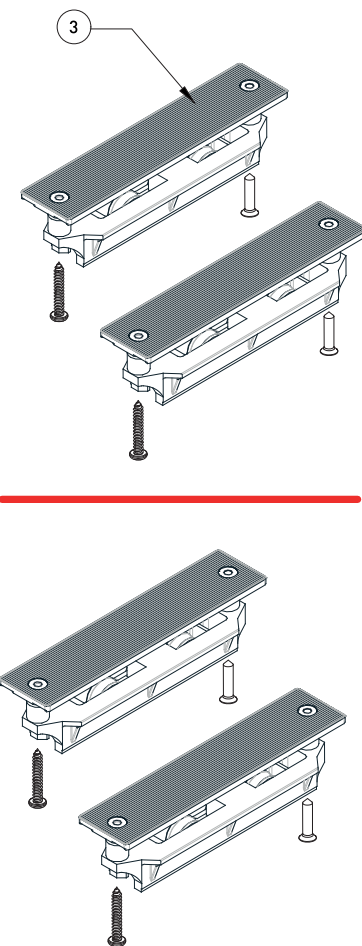

N.	Descrizione Description	Qt.
1	Squad. da 30x10 a doppio pulsante Corner joint from 30x10 with double button	8
2	Squad. allineamento per profilo anta Alignment Corner joint for sash profile	16
3	Carrello SX85-Anta maggiorata 240 Kg SX85-- 240 Kg TrolleyC	4
4	Tassello ammortizzatore/anti scarr. (Inferiore-Superiore) Shock absorber / anti-derail plug (Lower-Upper)	4
5	Tassello tenuta centrale superiore e inferiore Upper and lower central sealing gusset.	2
6	Vite autoforante TSPCR 3,9x25 inox Self-drilling screw TSPCR 3,9x25 inox	4
7	Tappo coprilavorazione SX85-120 Processing cap SX85-120	4
8	Vite autofilettante TSPCR 3,5x8 filetto UNI 6947 Self-tapping screw TSPCR 3,5x8 thread UNI 6947	4
9	Tappo copri tubolarità di rinforzo centrale SX85-120 SX85-120 central reinforcement tubular cap	4
10	Boccola di drenaggio Ø12-SV9-NE BC Drainage bush	4

N.	Descrizione Description	Qt.
11	Tappo coprilavorazione SX85-sup. SX 85 Upper Central Profile Finishing Plug	2



ASX.85.K2ALZ

Kit Mobile + Mobile Alzante

2 Sliding Sashes kit

[SX85.204/05/06/07/08]

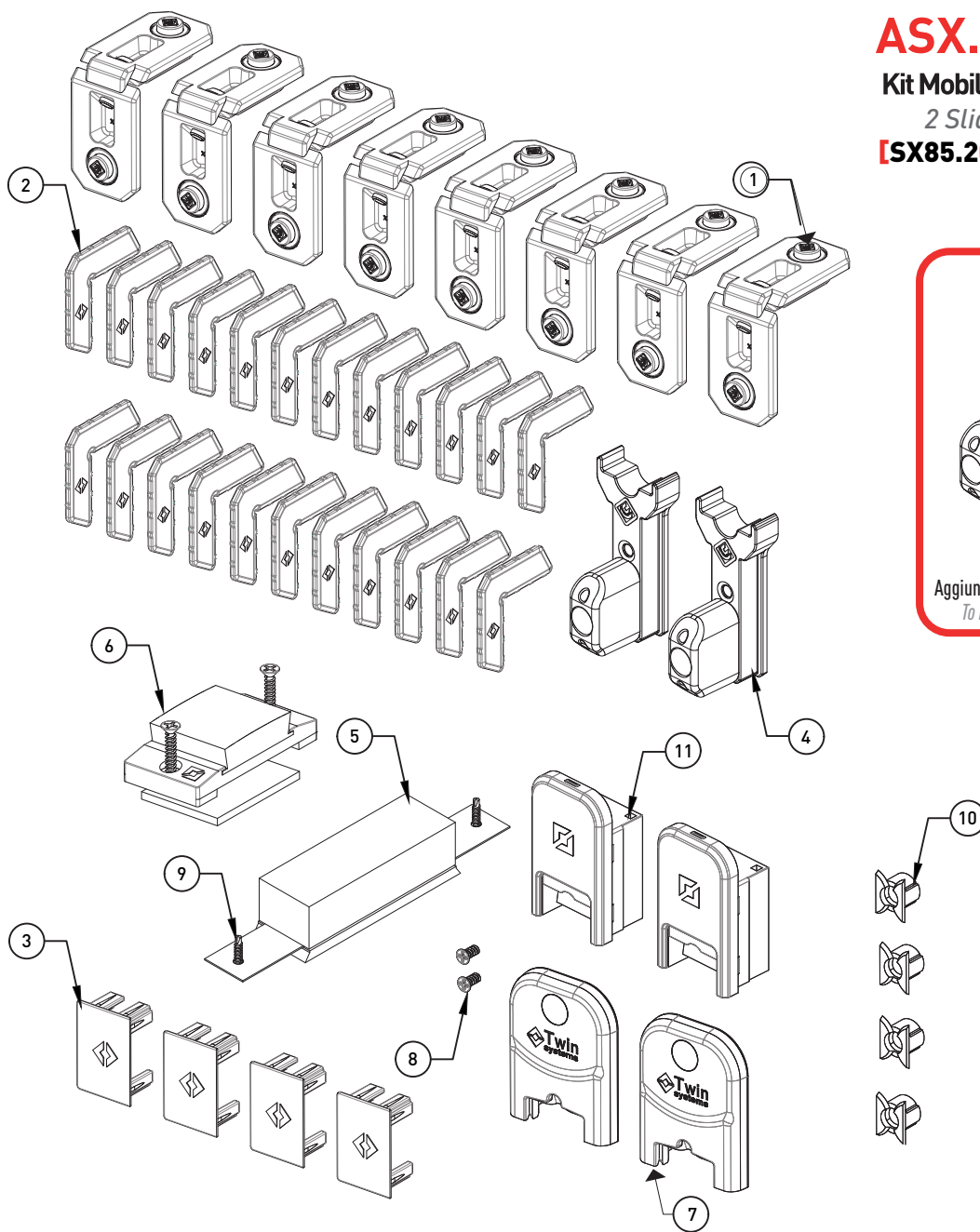

ASX.6845.3

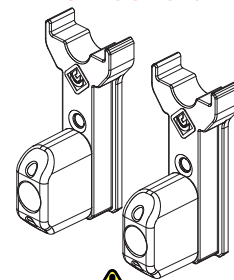

⚠
Aggiungere per Tipologia Scorrevole
To be Added for Sliding Types

N.	Descrizione Description	Qt.
1	Squad. da 30x10 a doppio pulsante Corner joint from 30x10 with double button	8
2	Squad. allineamento per profilo anta Alignment Corner joint for sash profile	24
3	Tappo copri tubolarità di rinforzo centrale SX85-120 SX85-120 central reinforcement tubular cap	4
4	Tassello ammortizzatore/anti scarr. (Superiore) Shock absorber / anti-derail plug (Upper)	2
5	Tassello tenuta centrale superiore Upper central sealing gusset.	1
6	Tassello tenuta centrale inferiore Lower central sealing gusset.	1
7	Tappo coprilavorazione inf. SX85-120 Processing cap SX85-120	2
8	Vite autofilettante TSPCR 3,5x8 filetto UNI 6947 Self-tapping screw TSPCR 3,5x8 thread UNI 6947	2
9	Vite autoforante TSPCR 3,9x25 inox Self-tapping screw TSPCR 3,9x25 inox	2
10	Boccola di drenaggio Ø12-SV9-NE BC Drainage bush	4

N.	Descrizione Description	Qt.
11	Tappo coprilavorazione sup. Processing cap	2

ALZANTE AS200

Alzante AS200

Portata 200 kg/Anta Load Capacity 200 kg/Sash

ANTE/SASHES:

SX85.201 | SX85.202 | SX85.203 | SX85.204

SX85.205 | SX85.206 | SX85.207 | SX85.208

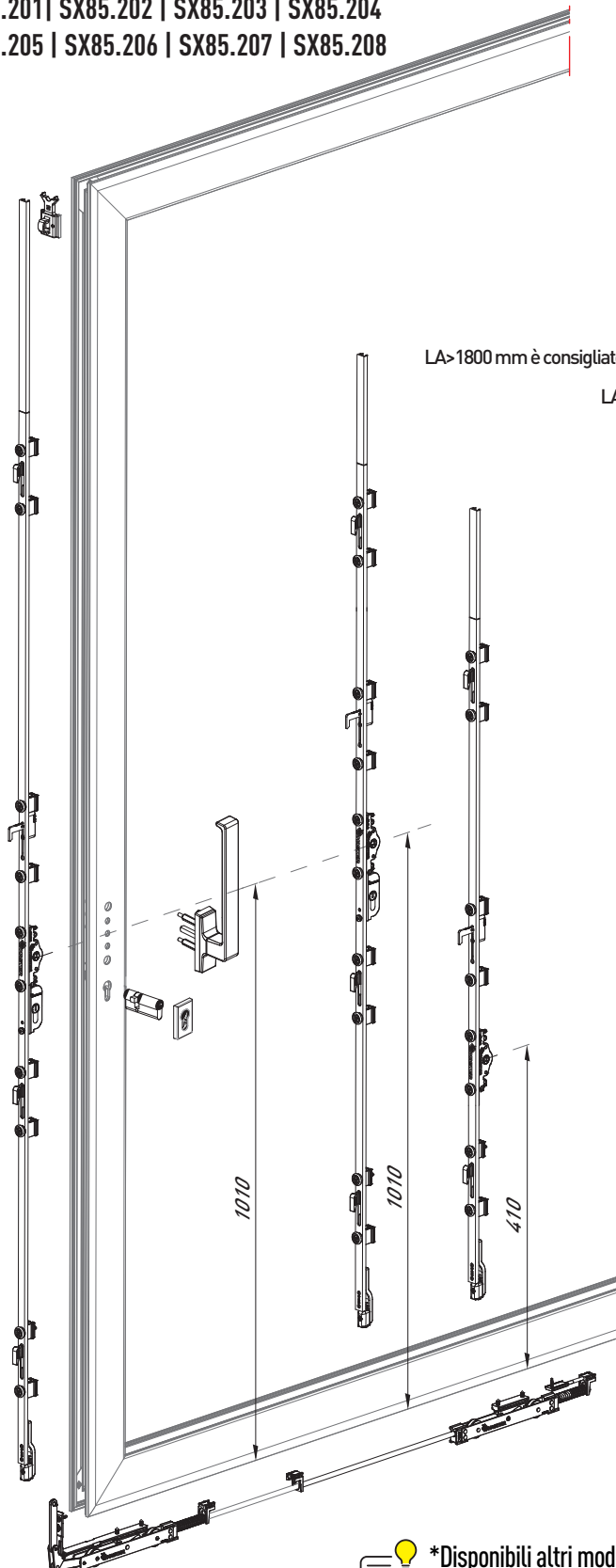

LA > 1800 mm è consigliato l'utilizzo del kit carrello supplementare Art. ASX.16.04

LA > 1800mm is recommended to use the additional roller

Kit cremonese Regolabile Adjustable Cremona Kit

Articolo/Item	Campo di applicazione Application range		
	H min	H max	N°chiusure No. of locks
ASX.16.00R	1295	1795	2
ASX.16.01R	1796	2295	3
ASX.16.02R	2296	2695	3

Kit cremonese 4 anta senza chiusure Cremona bolt kit 4 sash without locks

Articolo/Item	Campo di applicazione Application range		
	H min	H max	N°chiusure No. of locks
ASX.16.00SN	1295	1795	2
ASX.16.01SN	1796	2295	3
ASX.16.02SN	2296	2695	3

LA (anta) min. = 800 mm

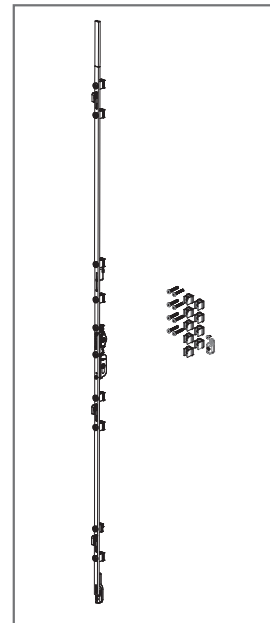

ASX.16.03

Kit carrelli - Trolley kit

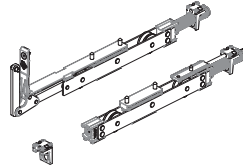

ASX.16.04

Carrello suppl. - Extra trolley

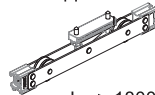

La > 1800 mm.

ASX.16.30

Contropiastra - Striker plate

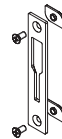

ASX.16.07

Maniglia di traino - Pull handle

"FAST LOCK"



ASX.16.31

Kit microventilazione
Micro-ventilation kit

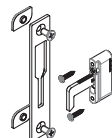

ASX.16.10

Kit serratura - Lock kit



ASX.16.15

Asta collegamento carrelli
Connecting rod
(L 1500 mm)



ASX.16.20

Martellina "ITALIA" 7 mm.
Handle "ITALY" 7 mm.

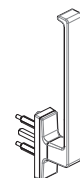

ASX.16.21

Copri-cilindro serratura
Lock cylinder cover
"ITALIA"



ASX.16.22

Martellina doppia "ITALIA" 7mm.
Double handle "ITALY" 7 mm.

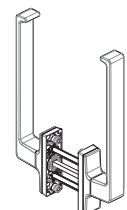

*Disponibili altri modelli
*available other types



ASX.85.K4AM

Kit tappi 4^a anta
4rd sash Cap Kit

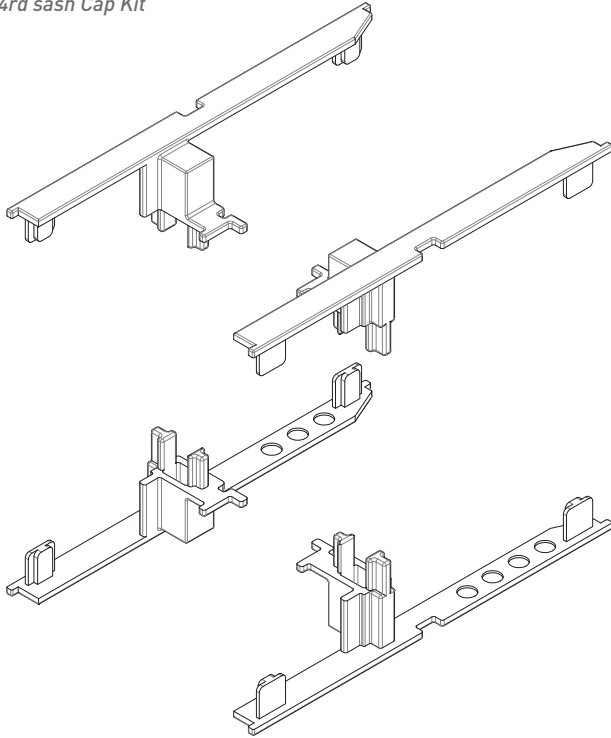

ASX.12.ANGFIS

Kit bloccaggio anta fissa
Fixed leaf locking kit

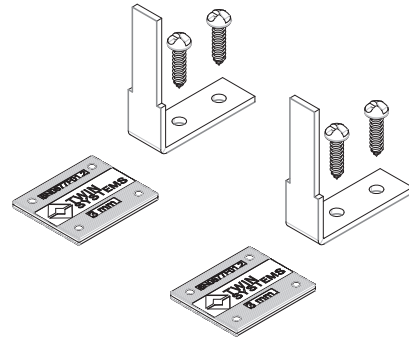

Solo per Anta Maggiorata SX85.201
Only for Oversized Sash SX85.201

Sostegno per Anta Fissa
Fixed Sash Support



*Ordinare separatamente dal kit
*To be order separatly of kit

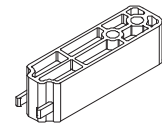

***ASX.6742.18**

ASX.85.KANG

Kit soluzione angolare DX - SX
RIGHT-LEFT corner solution kit

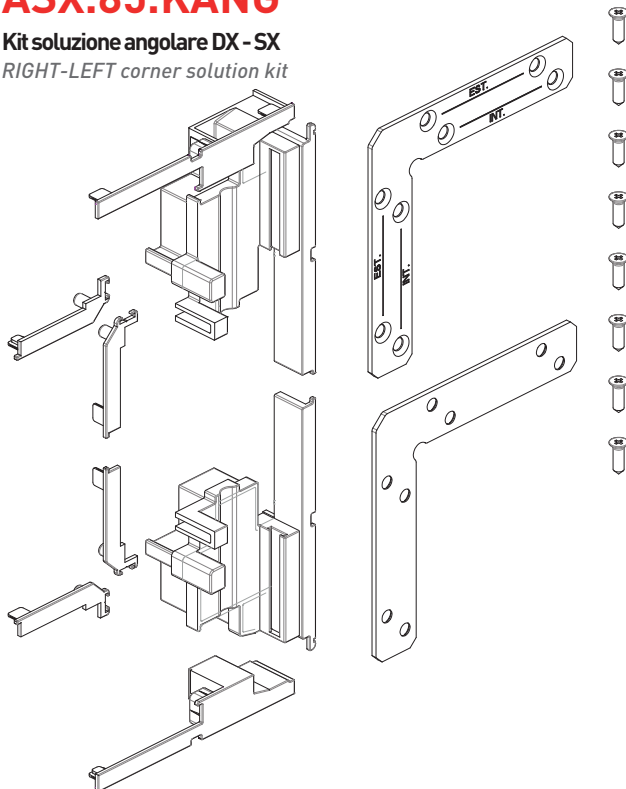

ASX.12.VASCH

Kit drenaggio con vaschetta telescopica
Drainage kit with telescopic tray

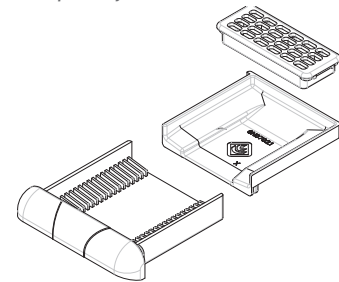

ASX.85.VASCH3V

Kit drenaggio con vaschetta
Drainage kit with tray

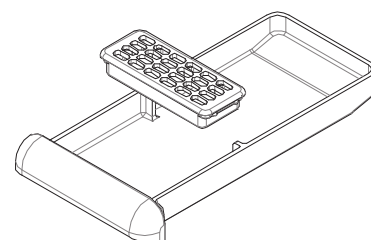



ASX.12.MTMDX / MTMSX

Kit maniglia singola movimentazione DX/SX
Single handle kit for RH / LT movement

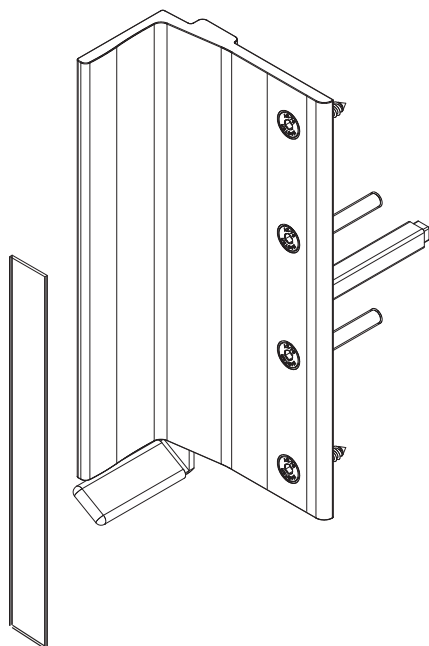

ASX.12.MTMDD

Kit maniglia doppia
Double handle kit

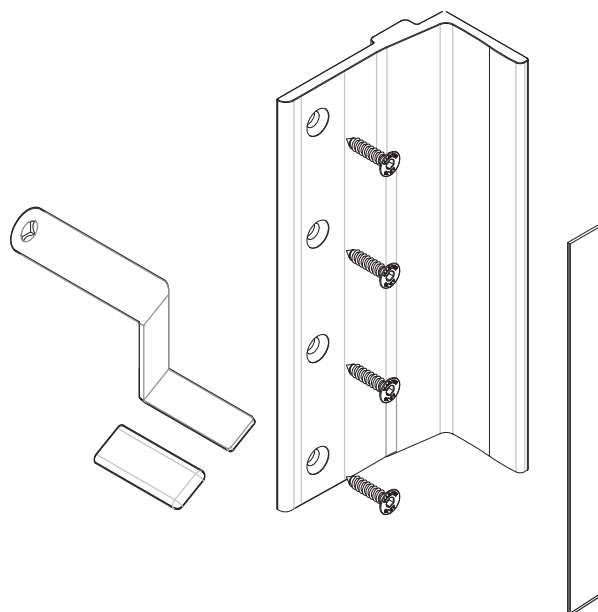

ASX.12.BLMT

Basetta laterale maniglia traino
Towing handle side base

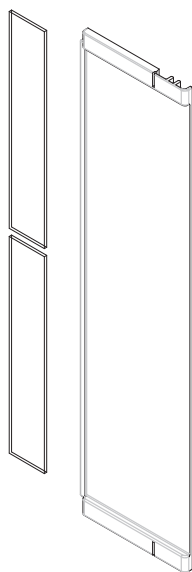

ASX.12.MTF

Maniglia traino FISSA
FIXED train handle

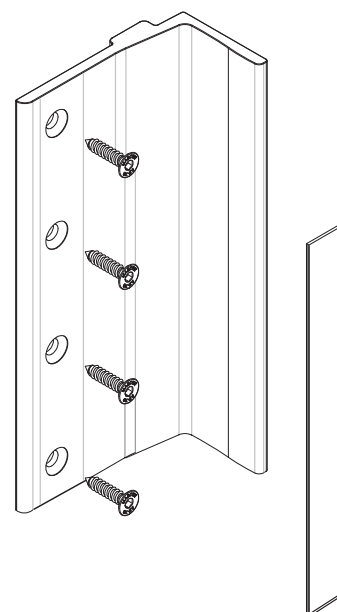

Griglia in ABS componibile per soglia L=300 mm.
Modular ABS grid for threshold L = 300 mm.



Anta MINIMALE
MINIMAL Sash

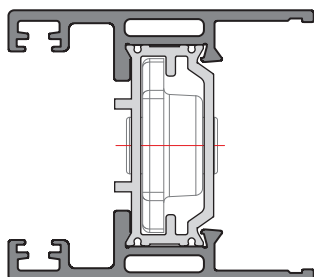

SX12.203

ASX.12.FAST60Z

Kit Fastlock su Anta H min 800 mm.
Kit Fastlock on Sash H min 800 mm.

"FASTLOCK ZINCATA"

Asta Chiusure Multiple (Multi Point Lock Bar) L=600 mm.
Punti di Chiusura (Multi Point Lock) Qt.= 2
Entrata (Backset) = 7.5 mm.

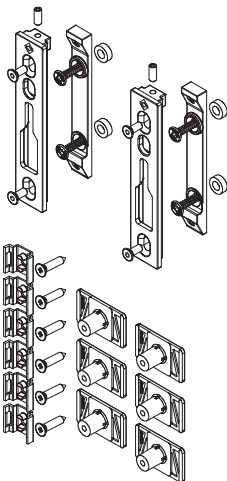

Aggiungere n° 1 Cover **ASX 08 80**
Add 1 covers ASX.08.80

Alternativa Alternative

ASX.12.FAST60

Kit Fastlock su Anta H min 1150 mm.
Kit Fastlock su Anta H min 750 mm.

"FASTLOCK INOX"

Asta Chiusure Multiple (Multi Point Lock Bar) L= 750 mm.
Punti di Chiusura (Multi Point Lock) Qt.= 2
Entrata (Backset) = 7.5 mm.



ASX.12.FAST100Z

Kit Fastlock su Anta H min 1200 mm.
Kit Fastlock on Sash H min 1200 mm.

"FASTLOCK ZINCATA"

Asta Chiusure Multiple (Multi Point Lock Bar) L=1200 mm.
Punti di Chiusura (Multi Point Lock) Qt.= 2
Entrata (Backset) = 7.5 mm.

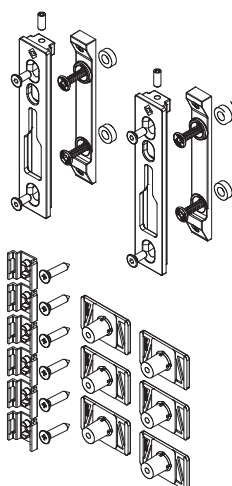

Aggiungere n° 1 Cover **ASX 08 80**
Add 1 covers ASX.08.80

Alternativa Alternative

ASX.12.FAST100

Kit Fastlock su Anta H min 1150 mm.
Kit Fastlock su Anta H min 1150 mm.

"FASTLOCK INOX"

Asta Chiusure Multiple (Multi Point Lock Bar) L= 1000 mm.
Punti di Chiusura (Multi Point Lock) Qt.= 2
Entrata (Backset) = 7.5 mm.



ASX.12.FAST180

Kit Fastlock su Anta H min 2000 mm.
Kit Fastlock on Sash H min 2000 mm.

"FASTLOCK ZINCATA"

Asta Chiusure Multiple (Multi Point Lock Bar) L=1800 mm.
Punti di Chiusura (Multi Point Lock) Qt.= 3
Entrata (Backset) = 7.5 mm.

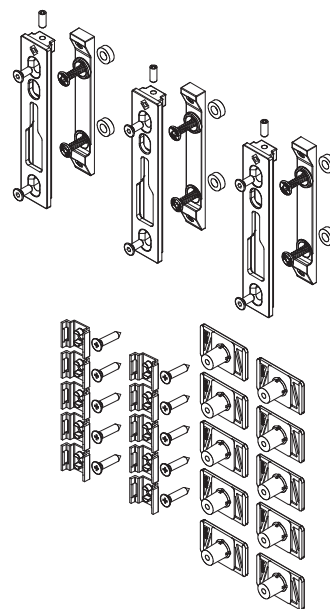

Aggiungere n° 1 Cover **ASX 08 80**
Add 1 covers ASX.08.80

Alternativa Alternative

ASX.12.FAST180

Kit Fastlock su Anta H min 1950 mm.
Kit Fastlock su Anta H min 1950 mm.

"FASTLOCK INOX"

Asta Chiusure Multiple (Multi Point Lock Bar) L= 1800 mm.
Punti di Chiusura (Multi Point Lock) Qt.= 3
Entrata (Backset) = 7.5 mm.



Da Integrare con KIT Supplementare **ASX08.82** / To be Integrated with Supplementary KIT **ASX08.82**



Anta MAGGIORATA
OVERSIZED Sash

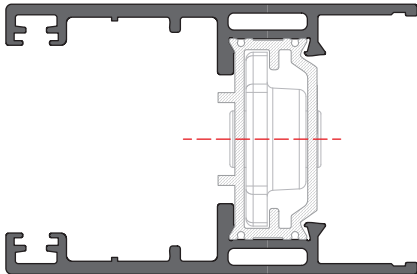

SX85.201

ASX.85.02

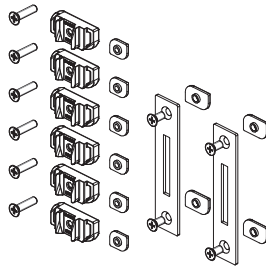

Kit Riscontri
Fastlock kit

ASX.85.04

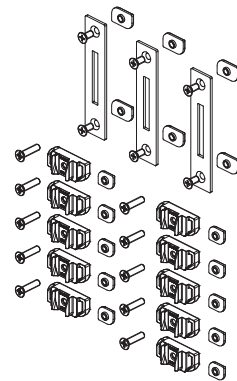

Kit Riscontri
Fastlock kit

ASX.85.02

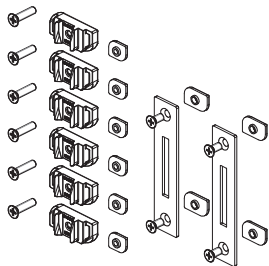

Kit Riscontri
Fastlock kit

ASX.13.02

Fastlock su anta H min. 750 mm.
Fastlock on Sash H min. 750 mm.

"FASTLOCK ZINCATA"

Chiusura multipunto L=600 mm.-2 punti chius. Entr. 15 mm.
Multi-point locking L=600 mm.-2 locking points Backset 15 mm.

ASX.13.03

Kit Fastlock su anta H min. 1150 mm.
Fastlock kit on Sash H min. 1150 mm.

"FASTLOCK ZINCATA"

Chius. multip. L=1000 mm.-2 punti chius. Entr. 15 mm.
Multi-point lock L=1000 mm.-2 locking point Backset 15 mm.

ASX.13.04

Kit Fastlock
su anta H min. 1950 mm.
Fastlock kit

on Sash H min. 1950 mm.

"FASTLOCK ZINCATA"

Chius. multip. L=1800 mm.
3 punti chius. Entr. 15 mm.

Multi-point lock L=1800 mm.
3 locking point Backset 15 mm.

ASX.13.05

Kit FastBlock
su anta H min. 1950 mm.
Fastlock kit

on Sash H min. 1950 mm.

"FASTLOCK ZINCATA"

Chius. multip. L=1800 mm.
3 punti chius. Entr. 15 mm.

Multi-point lock L=1800 mm.
3 locking point Backset 15 mm.



Anta MAGGIORATA
OVERSIZED Sash

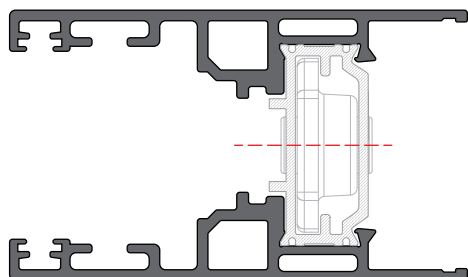

SX85.206

ASX.85.07

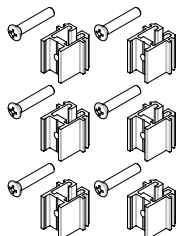

Kit Riscontri
Fastlock kit

ASX.13.02

Fastlock su anta H min. 750 mm.
Fastlock on Sash H min. 750 mm.

"FASTLOCK ZINCATA"

Chiusura multipunto L=600 mm.-2 punti chius. Entr. 15 mm
Multi-point locking L=600 mm.-2 locking points Backset 15 mm.

ASX.85.07

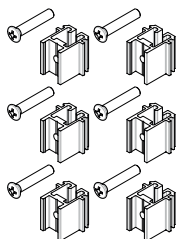

Kit Riscontri
Fastlock kit

ASX.13.03

Kit Fastlock su anta H min. 1150 mm.
Fastlock kit on Sash H min. 1150 mm.

"FASTLOCK ZINCATA"

Chius. multip. L=1000 mm.-2 punti chius. Entr. 15 mm
Multi-point lock L=1000 mm.-2 locking point Backset 15 mm.

ASX.85.08

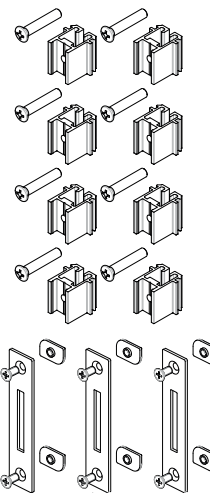

Kit Riscontri
Fastlock kit

ASX.13.04

Kit Fastlock
su anta H min. 1950 mm.
Fastlock kit

on Sash H min. 1950 mm.

"FASTLOCK ZINCATA"

Chius. multip. L=1800 mm.
3 punti chius. Entr. 15 mm.

Multi-point lock L=1800 mm.
3 locking point Backset 15 mm.

ASX.13.05

Kit FastBlock
su anta H min. 1950 mm.
Fastlock kit

on Sash H min. 1950 mm.

"FASTLOCK ZINCATA"

Chius. multip. L=1800 mm.
3 punti chius. Entr. 15 mm.

Multi-point lock L=1800 mm.
3 locking point Backset 15 mm.



Alternative guarnizioni di tenuta

Sealing gasket alternatives

Applicazione con | Application w/

ASX.10.34

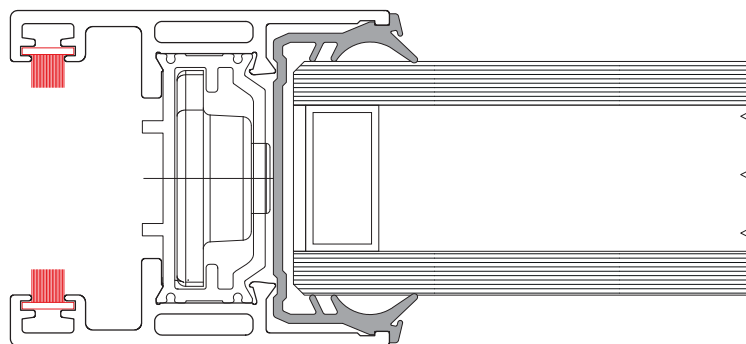

Applicazione con | Application w/

ASX.10.69

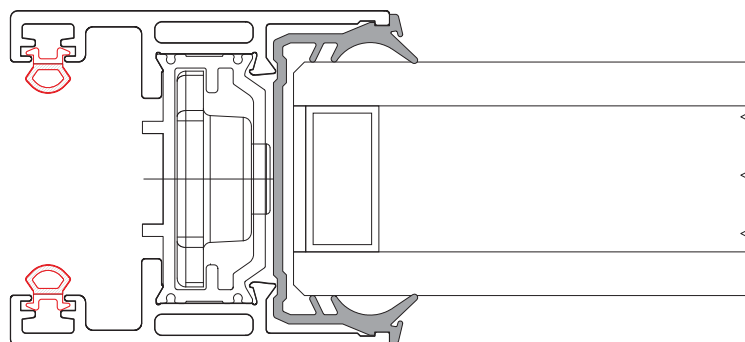

Alternative di vetrazioni



Alternative Glazing

Guarnizione | Gasket

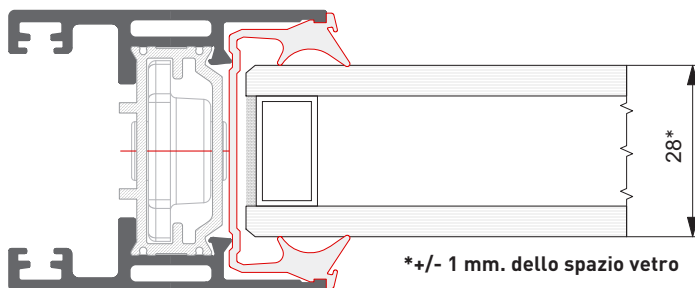
ASX.10.80

Guarnizione | Gasket

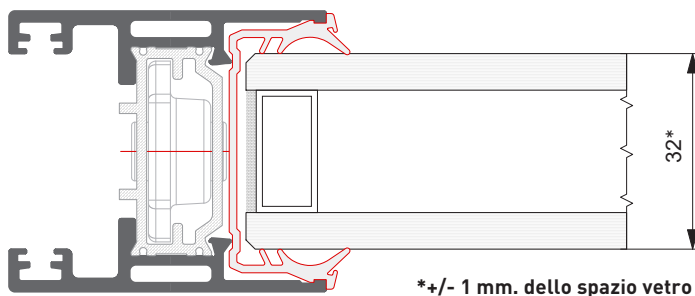
ASX.10.74

Nastro biadesivo | Double sided tape

(16.5 mm. x 1.1 mm.)

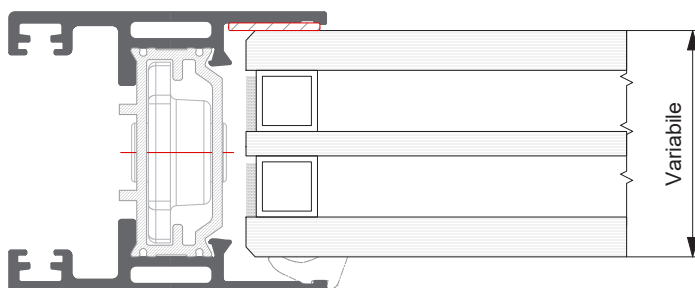
AS 5952F.16**Sigillare internamente l'anta
prima di inserire il vetro***Internally seal the sash before
inserting glass*



Alternative di vetrage

ASX.10.33

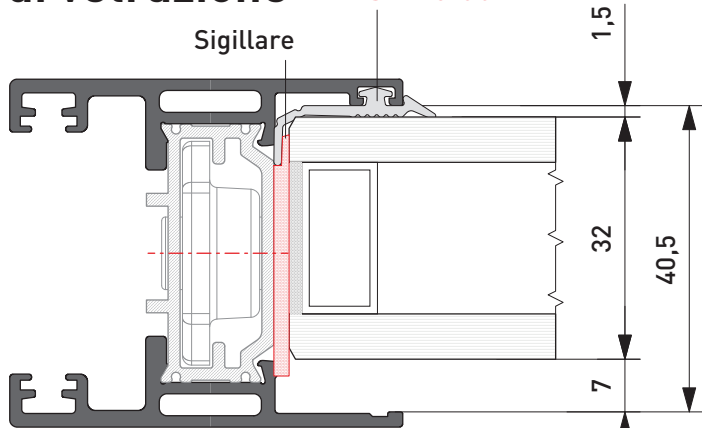

Nastro biadesivo
(16.5 mm x 1.1 mm)

AS 5952F.16

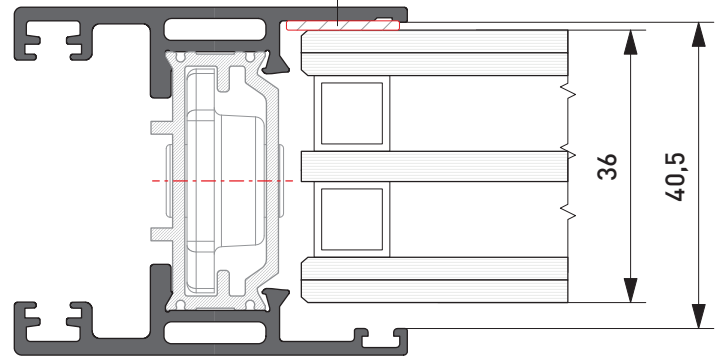

Sigillare ASX.10.33

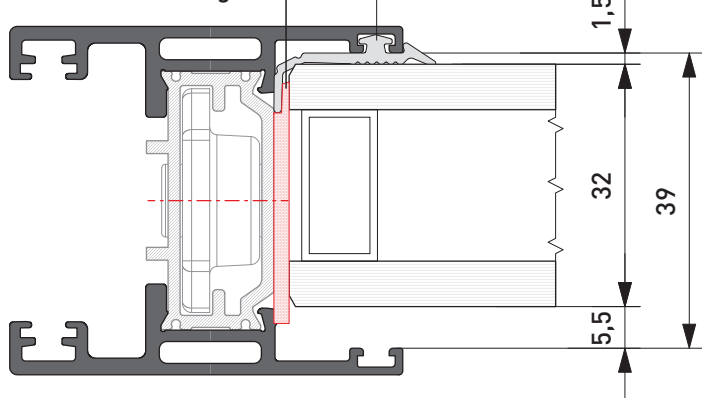

Sigillare* internamente l'anta prima di inserire il vetro
Internally seal the sash before inserting glass*

*SIGILLANTE = SIKAFLEX 521 o equivalente
*SEALANT = SIKAFLEX 521 or equivalent

Sigillare ASX.10.33

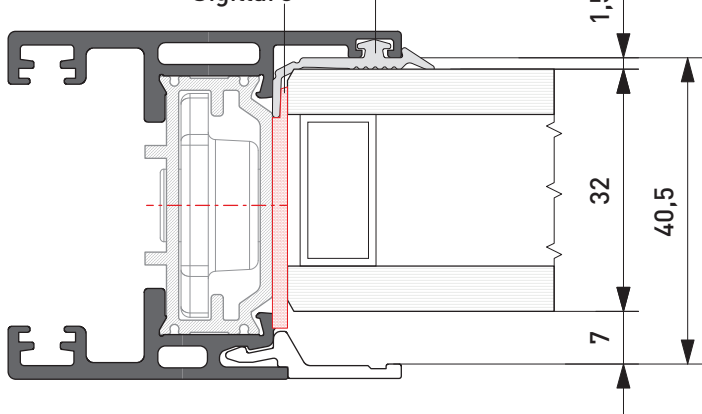

AS 5952F.16 Nastro biadesivo
(16.5 mm x 1.1 mm)

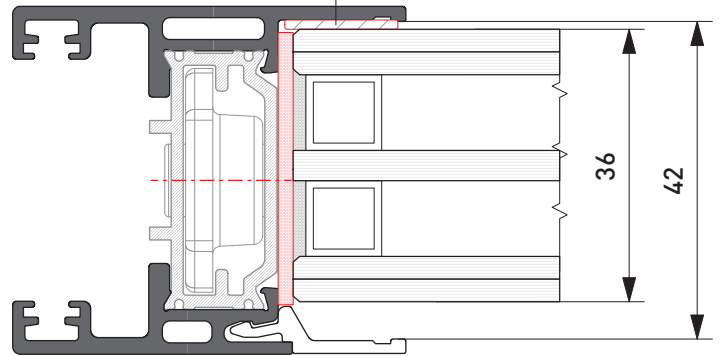

Sigillare ASX.10.33

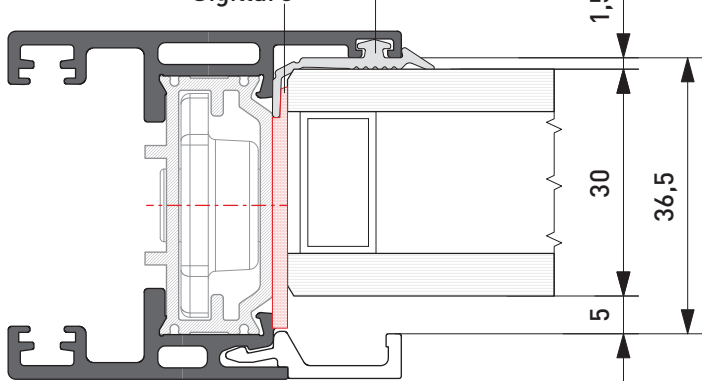

AS 5952F.16 Nastro biadesivo
(16.5 mm x 1.1 mm)

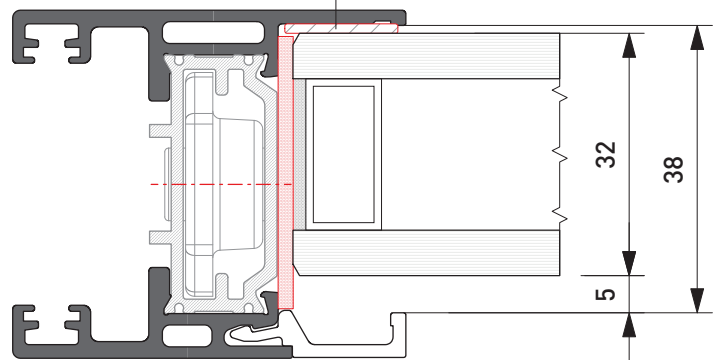



Materiale di Incollaggio I Bonding Material

AS 94	PRIMER Trasparente <i>Transparent PRIMER</i>	
AS 5952F.16	NASTRO Biadesivo <i>Double Sided Adhesive Tape</i>	
AS VHB C	Pulitore Superfici per Adesione <i>Surface Cleaner</i>	
AS VHB GLA	Promotore Adesione Vetro <i>Glass Adhesion Promoter</i>	
AS Industrial Cleaner	Pulitore Superfici di Adesione Vetro per Rimozione Vetro <i>Adhesive Glass Adhesive Surfaces Cleaner for Glass Removal</i> *Per rimozione vetro incidere con un cutter il nastro e poi utilizzare AS Industrial Cleaner *For glass removal, etch the tape with a cutter and then use AS Industrial Cleaner	

TECNICHE DI APPLICAZIONE

Preliminari:

Disporre il serramento in piano.

Pulizia:

Per la maggior parte dei substrati è sufficiente una pulizia con **3M VHB Surface Cleaner**, pulitore per superfici (nostro articolo **AS VHB C** prima dell'applicazione del nastro, utilizzando un panno pulito, diretto verso una sola direzione, cioè da sx a dx e ancora da sx a dx, senza movimenti circolari, che avrebbero la sola funzione di diffondere lo sporco. In presenza di forti contaminazioni quali oli pesanti o grasso, è necessario utilizzare un prodotto sgrassante a base solvente e infine pulire con **3M VHB Surface Cleaner**.

Abrasione:

Qualora il serramento, anziché verniciato, fosse anodizzato, dopo la prima pulizia occorrerebbe effettuare una leggera abrasione ed una seconda pulizia. L'abrasione di una superficie, seguita da pulizia con **3M VHB Surface Cleaner**, oltre ad eliminare le asperità più evidenti, svolge una duplice funzione: rimuovere sporco ostinato o strati di ossido da metalli o vernici ed aumentare l'area superficiale per migliorare l'adesione. In generale si può ottenere una superficie correttamente abrasa con **3MTM Scotch-Brite TM 7447**.

Promotori di adesione:

Passare il primer 94 (nostro articolo **AS 94**) con uno strumento pulito (pennello nuovo per esempio) sul serramento.

Passare il **Silane primer** sul vetro, (nostro articolo **AS VHB GLA**) in quantità infinitesimali. Per fare ciò il primer con un panno va applicato, con un altro panno va tolto: movimento del tipo "metti e togli".

Applicare sul serramento il **VHB** (nostro articolo **AS 5952F.16** premere il nastro con una spatolina o un rullo (il **3M VHB** è un pressure sensitive adhesive, per attivarsi ha bisogno di una leggera pressione). Non occorre una pressa, ma una semplice pressione manuale.

Togliere il liner; se è necessario presentare il vetro togliendo solo una parte del liner, posizionare e sistemare il vetro, sfilare il resto del liner. Installare il vetro, premendo manualmente il vetro stesso.

Tempo:

A temperatura ambiente, si raggiungerà il 50% della tenuta finale dopo circa 20 minuti, il 90% dopo 24 ore e il 100% dopo 72 ore.

Nota: almeno per 1 ora non mettere il serramento-vetro in verticale, a meno che non ci sia un sistema per evitare che il vetro gravi sul nastro (zeppa o simile). Il prodotto è movimentabile da subito.

APPLICATION TECHNIQUES

Preliminary:

Lay the window frame flat.

Cleaning:

For most substrates, cleaning with **3M VHB Surface Cleaner**, surface cleaner (our article **AS VHB C** prior to tape application is sufficient, using a clean cloth, directed in one direction only, i.e., from left to right and again from left to right, without circular motions, which would only serve the function of spreading dirt. If there is heavy contamination such as heavy oils or grease, a solvent-based degreasing product should be used and finally cleaned with **3M VHB Surface Cleaner**.

Abrasion:

Should the window frame, instead of painted, be anodized, light abrasion and a second cleaning should be performed after the first cleaning. Abrasion of a surface, followed by cleaning with **3M VHB Surface Cleaner**, in addition to removing the most obvious roughness, serves a dual function: to remove stubborn dirt or oxide layers from metal or paint and to increase the surface area to improve adhesion. In general, a properly abraded surface can be achieved with **3MTM Scotch-Brite TM 7447**.

Adhesion promoters:

Pass Primer 94 (our **AS 94** article) with a clean tool (new brush for example) on the window frame. Pass Silane primer over the glass, (our article **AS VHB GLA**) in infinitesimal amounts. To do this the primer with a cloth should be applied, with another cloth it should be removed: "put on and take off" type movement. Apply VHB (our article **AS 5952F.16**) to the window or door frame, press the tape with a spatula or roller (**3M VHB** is a pressure sensitive adhesive, it needs light pressure to activate). There is no need for a press, just manual pressure. Remove the liner; if it is necessary to present the glass by removing only part of the liner, position and arrange the glass, slip off the rest of the liner. Install the glass, pressing the glass down by hand.

Time:

At room temperature, 50% of the final seal will be reached after about 20 minutes, 90% after 24 hours, and 100% after 72 hours.

Note: At least for 1 hour, do not put the window-glass vertically, unless there is a system to prevent the glass from bearing down on the tape (wedge or similar). The product can be handled immediately.



Nodi
Main Sections

Gruppo D

Sezioni principali
e Accessori
Sc. 1:1

Main Sections and
Accessories
Scale 1:1



SCORREVOLE A SCOMPARSA
Laterale Interno
CONCEALED SLIDING DOOR
Internal side

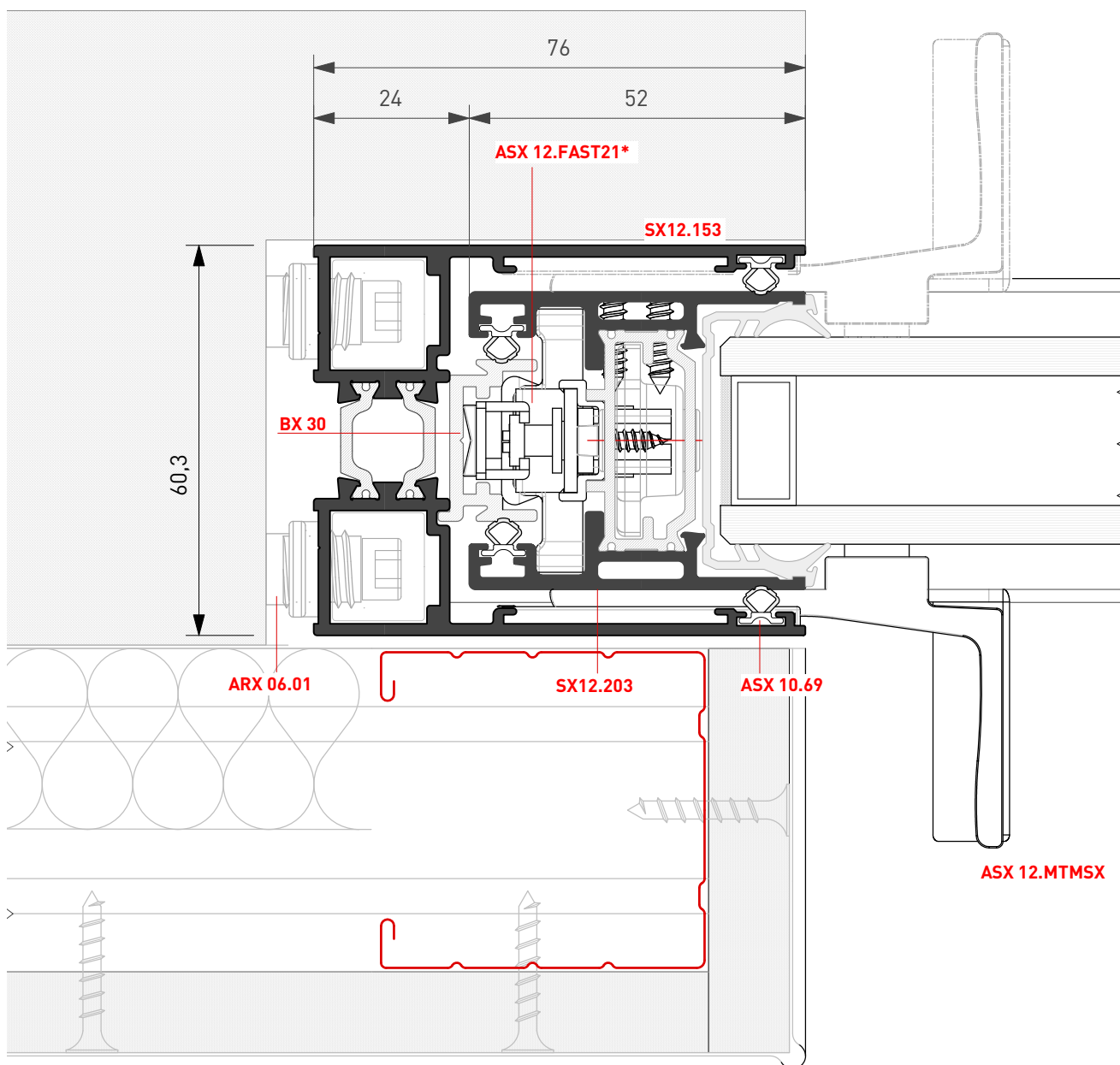

* Disponibili varianti
* Variants available



SCORREVOLE A SCOMPARSA
Laterale Interno
CONCEALED SLIDING DOOR
Internal side

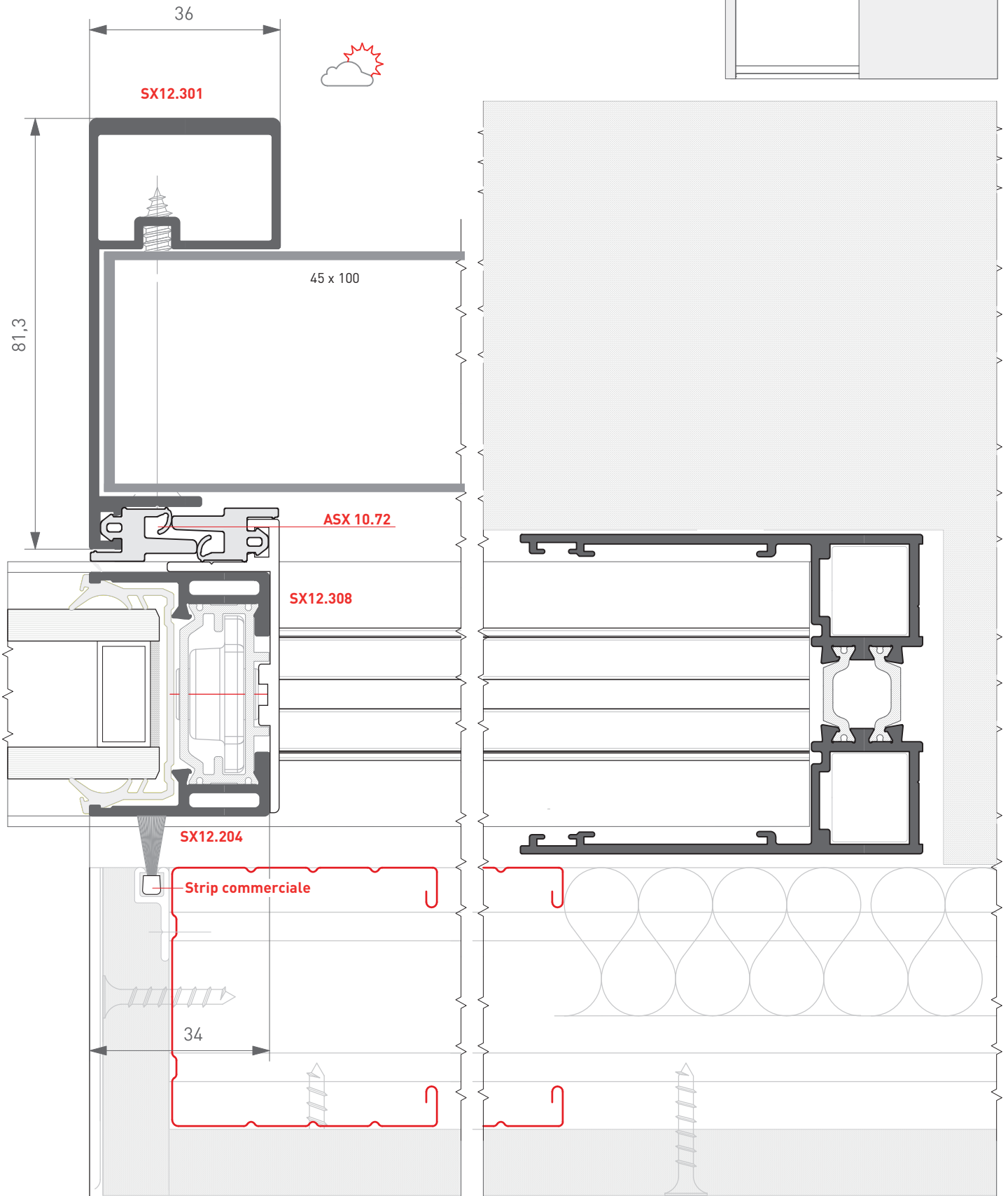
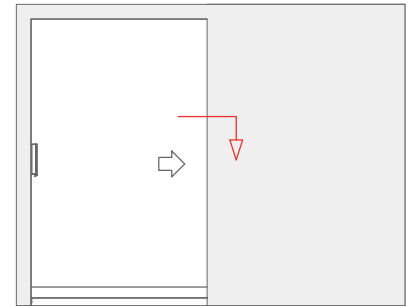



SCORREVOLE A SCOMPARSA
Verticale
CONCEALED SLIDING DOOR
Vertical

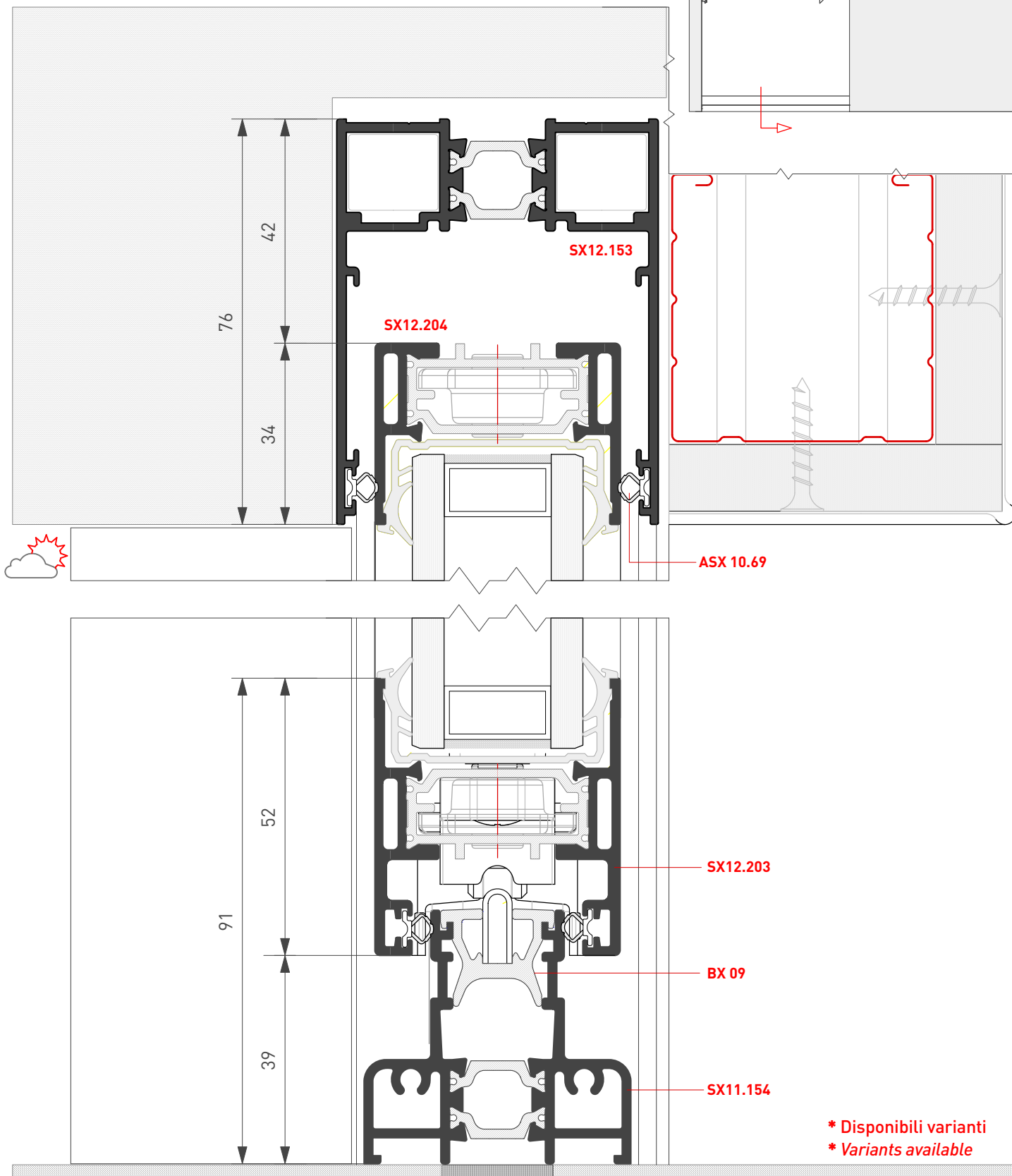

* Disponibili varianti
* Variants available



SCORREVOLE A 2 ANTE MOBILI
Laterale Interno

SLIDING DOOR WITH 2 MOVABLE DOORS
Internal side

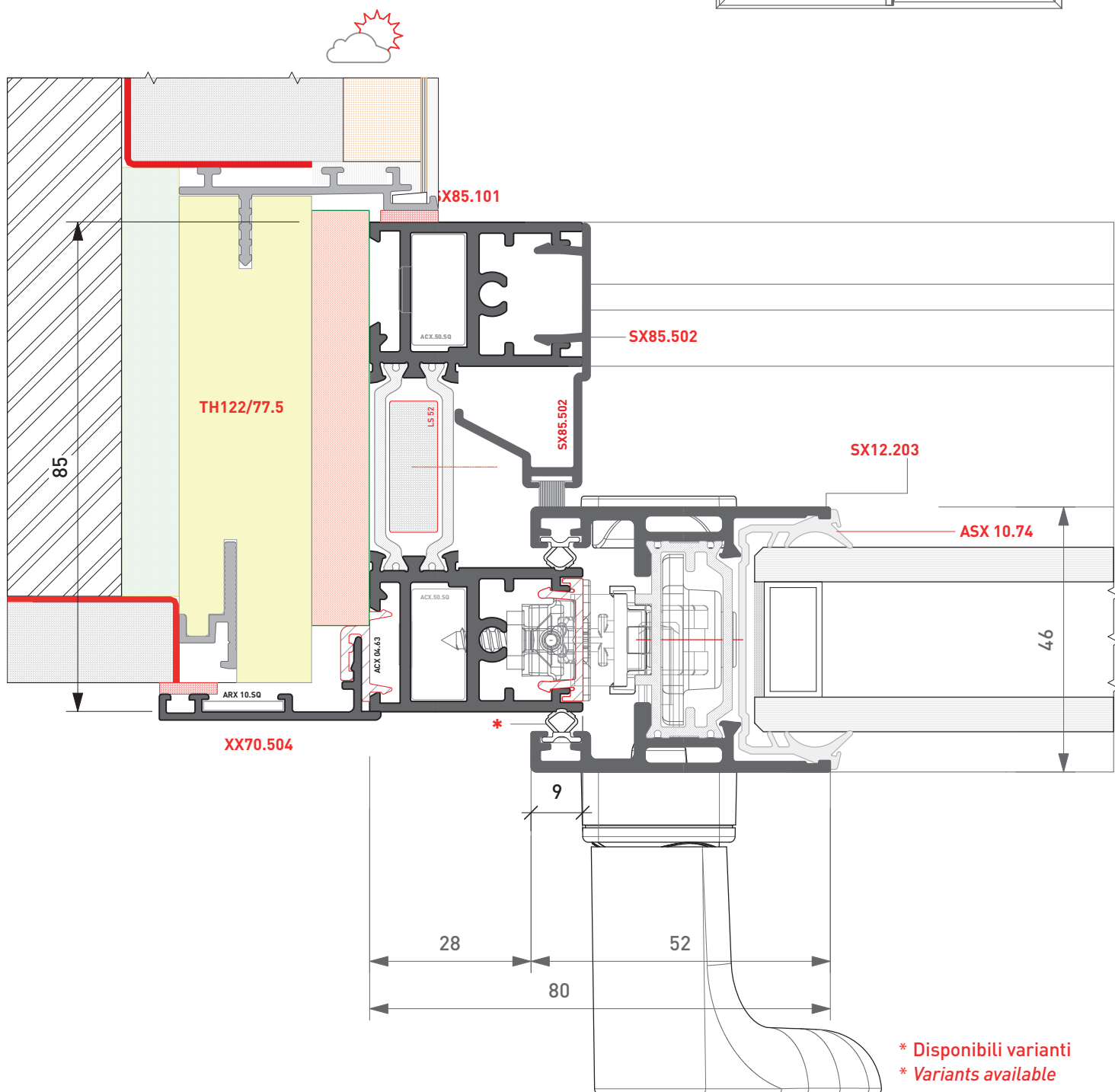
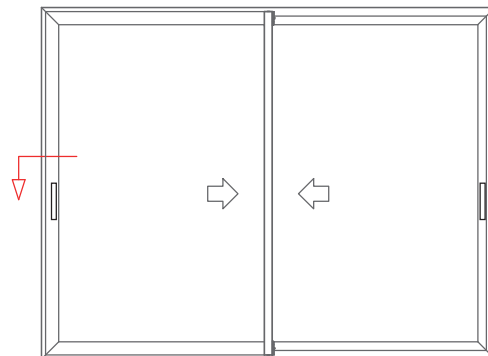

* Disponibili varianti
* Variants available



SCORREVOLE A 2 ANTE MOBILI
Centrale

SLIDING DOOR WITH 2 MOVABLE DOORS
Central

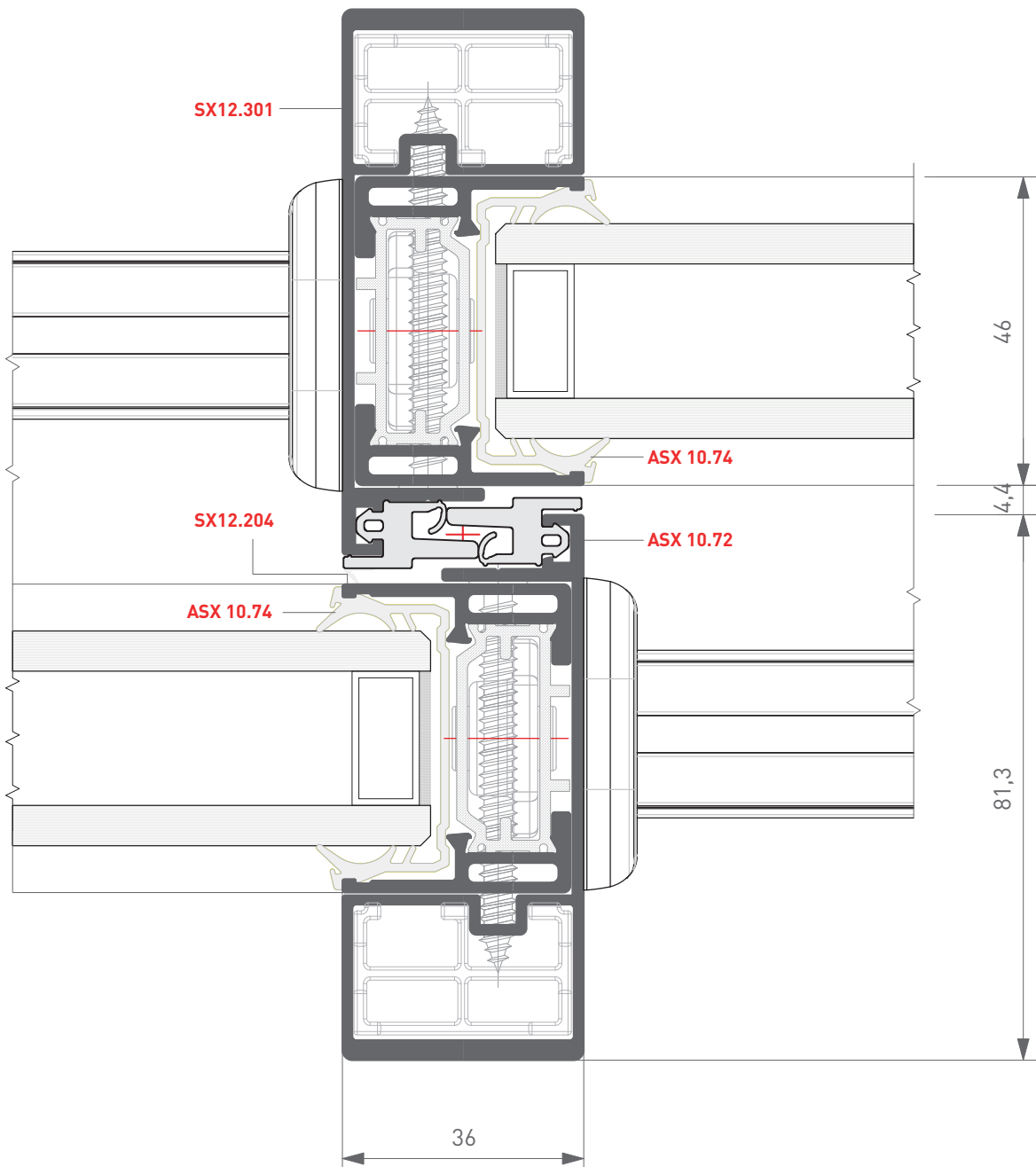
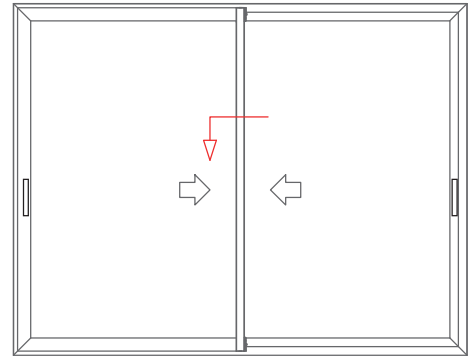



SCORREVOLE A 2 ANTE MOBILI
Centrale Rinforzato

SLIDING DOOR WITH 2 MOVABLE DOORS
Reinforced Central

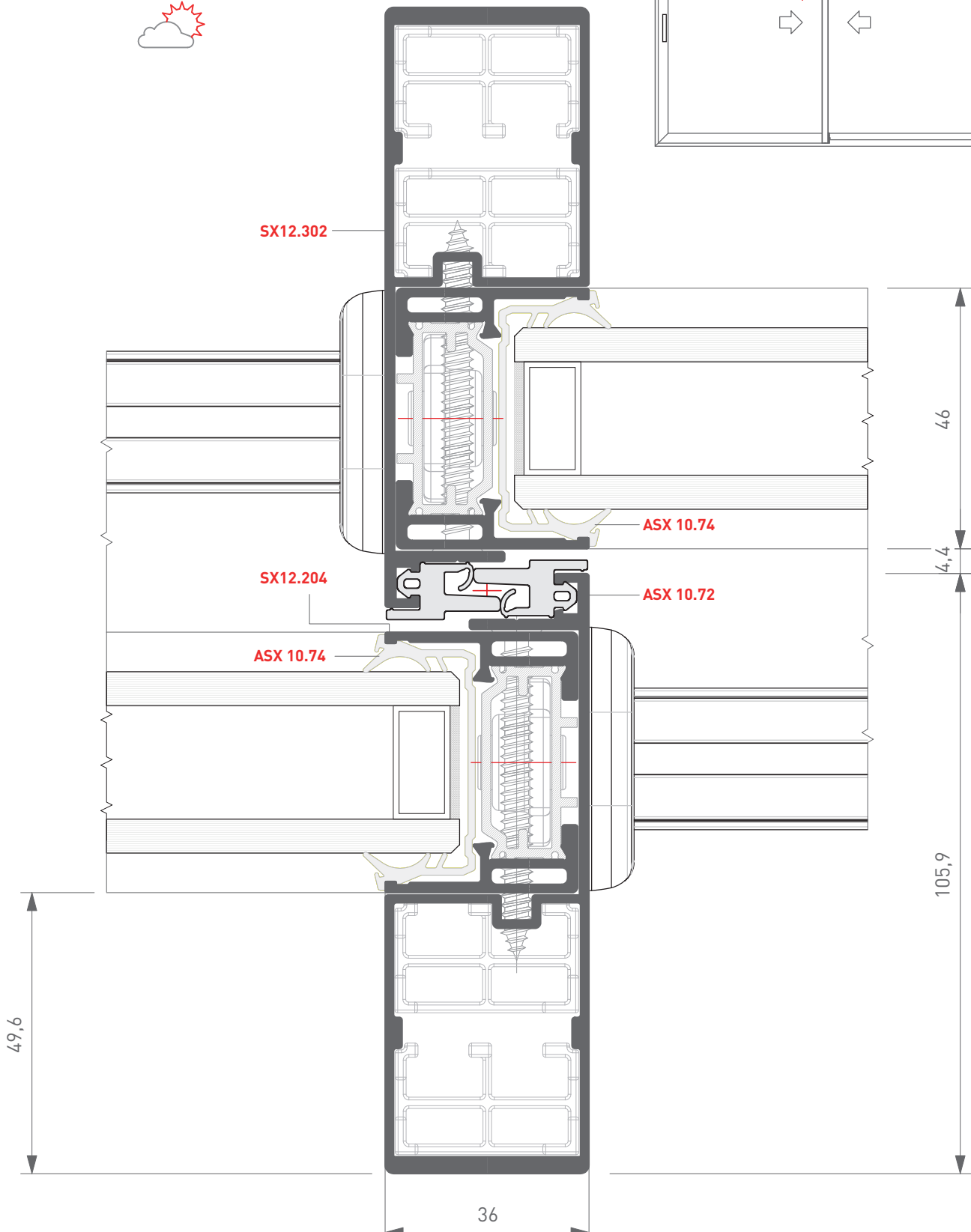
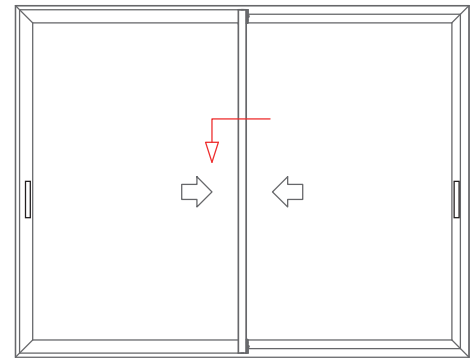



SCORREVOLE A 2 ANTE MOBILI
Centrale sicurezza
SLIDING DOOR WITH 2 MOVABLE DOORS
Central safety profile

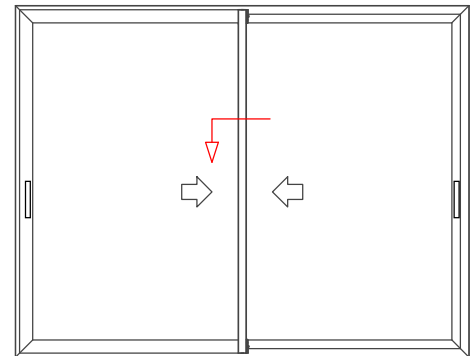

Valido per Certificazione Antieffrazione RC3
Valid for RC3 Burglarproof Certification

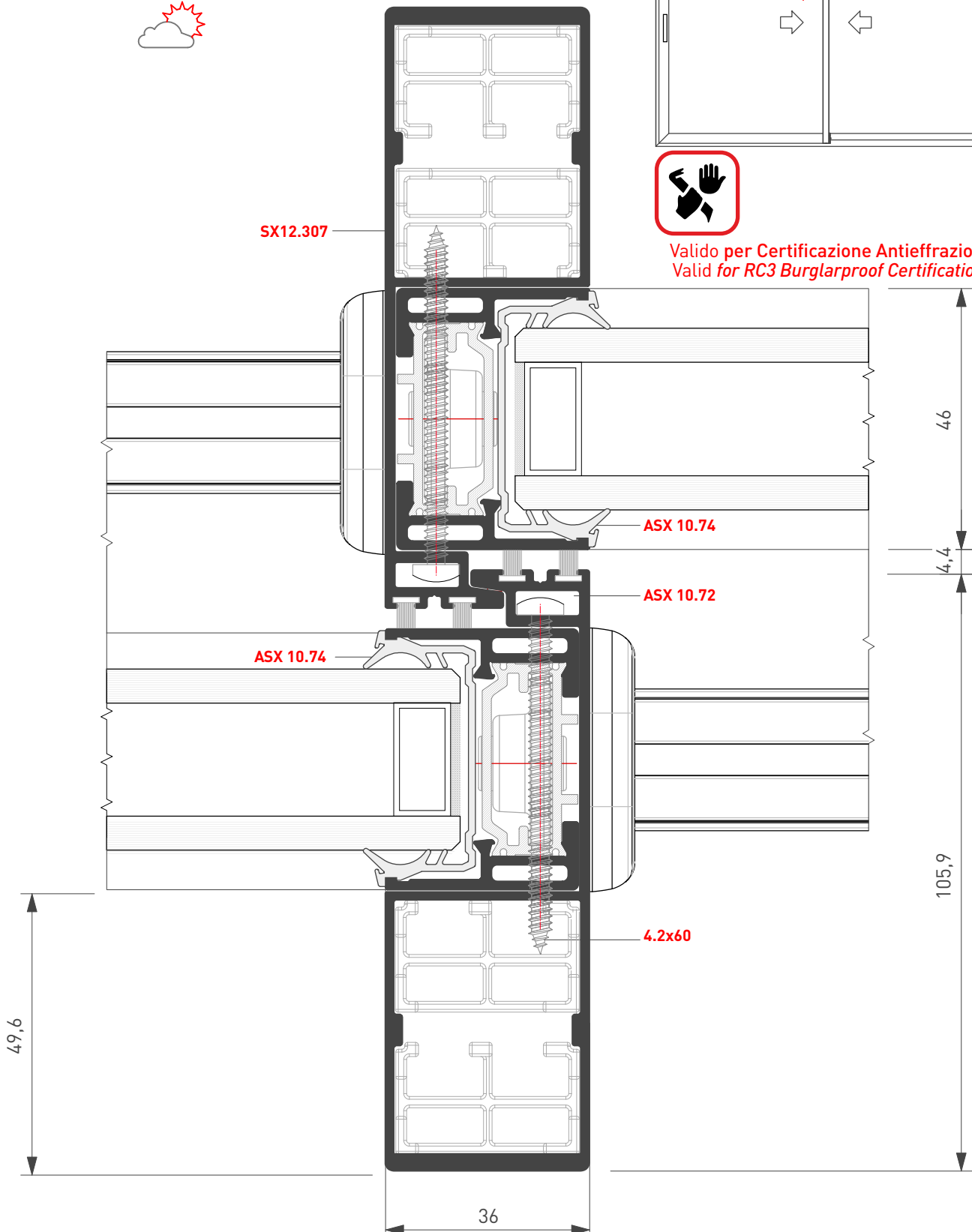



SCORREVOLE A 2 ANTE MOBILI
Centrale Rinforzato e Ridotto

SLIDING DOOR WITH 2 MOVABLE DOORS Reinforced central profile and reduced profile

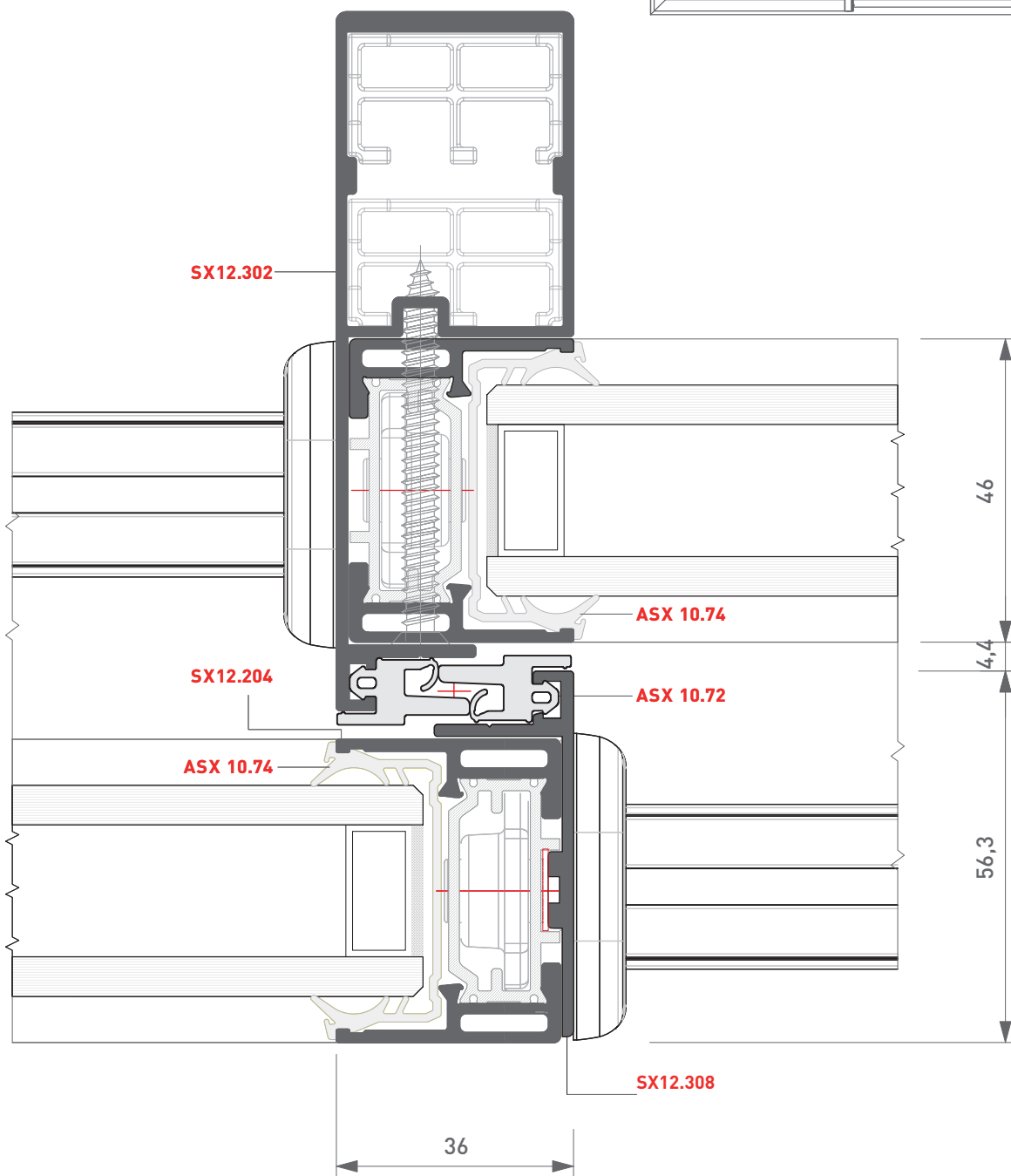
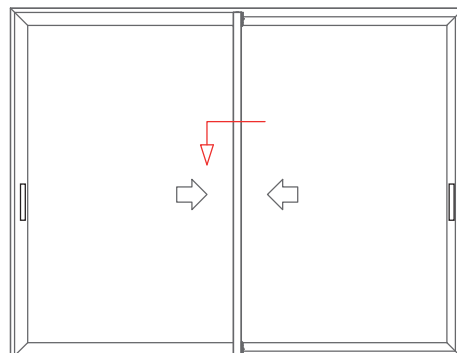



SCORREVOLE A 2 ANTE MOBILI
Laterale Esterno

SLIDING DOOR WITH 2 MOVABLE DOORS
External Side

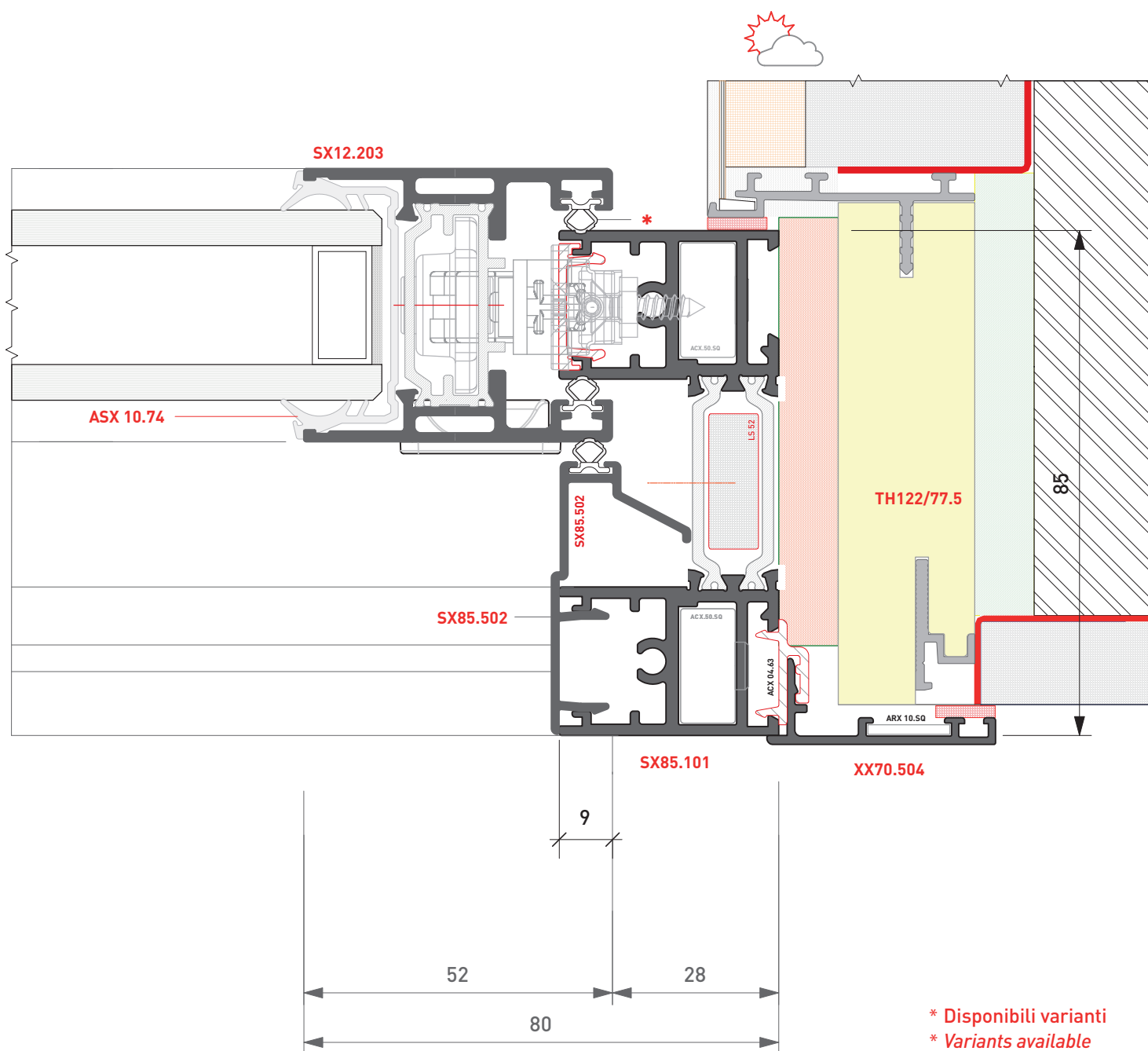
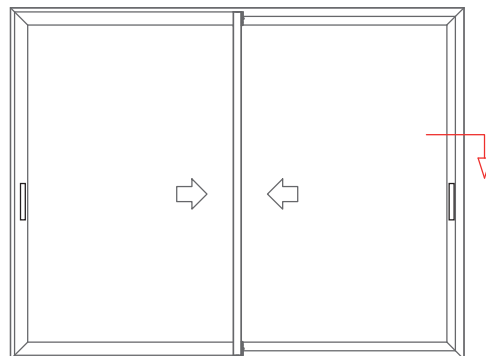

* Disponibili varianti
* Variants available



SCORREVOLE A 2 ANTE MOBILI
Superiore
SLIDING DOOR WITH 2 MOVABLE DOORS
Superior

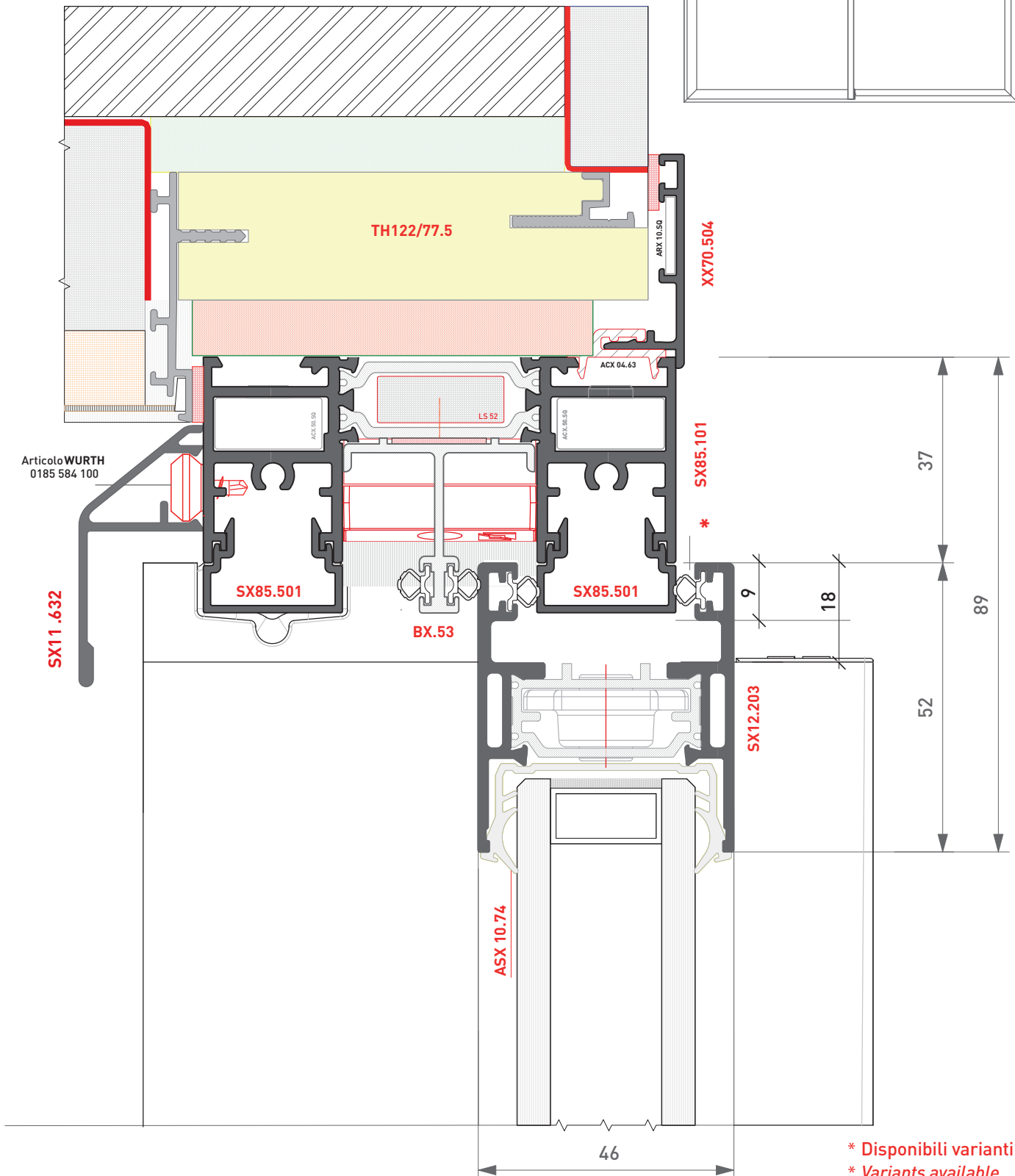
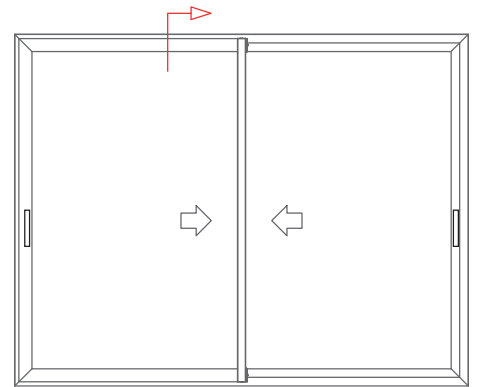

* Disponibili varianti
* Variants available



SCORREVOLE A 2 ANTE MOBILI
Centrale esterno ridotto
Inferiore

SLIDING DOOR WITH 2 MOVABLE DOORS
Reduced external central profile
Inferior

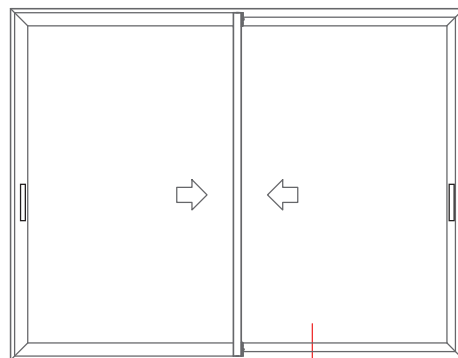

Profilo zanzariera piccolo standard

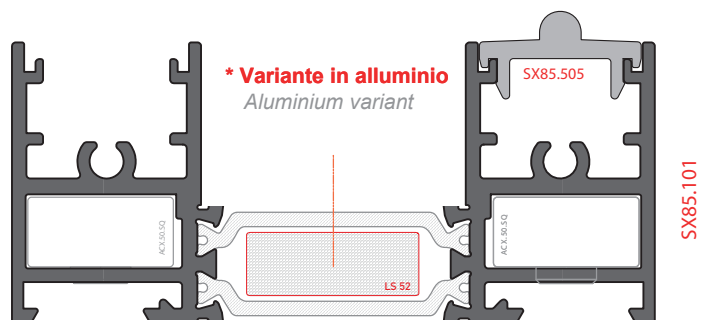
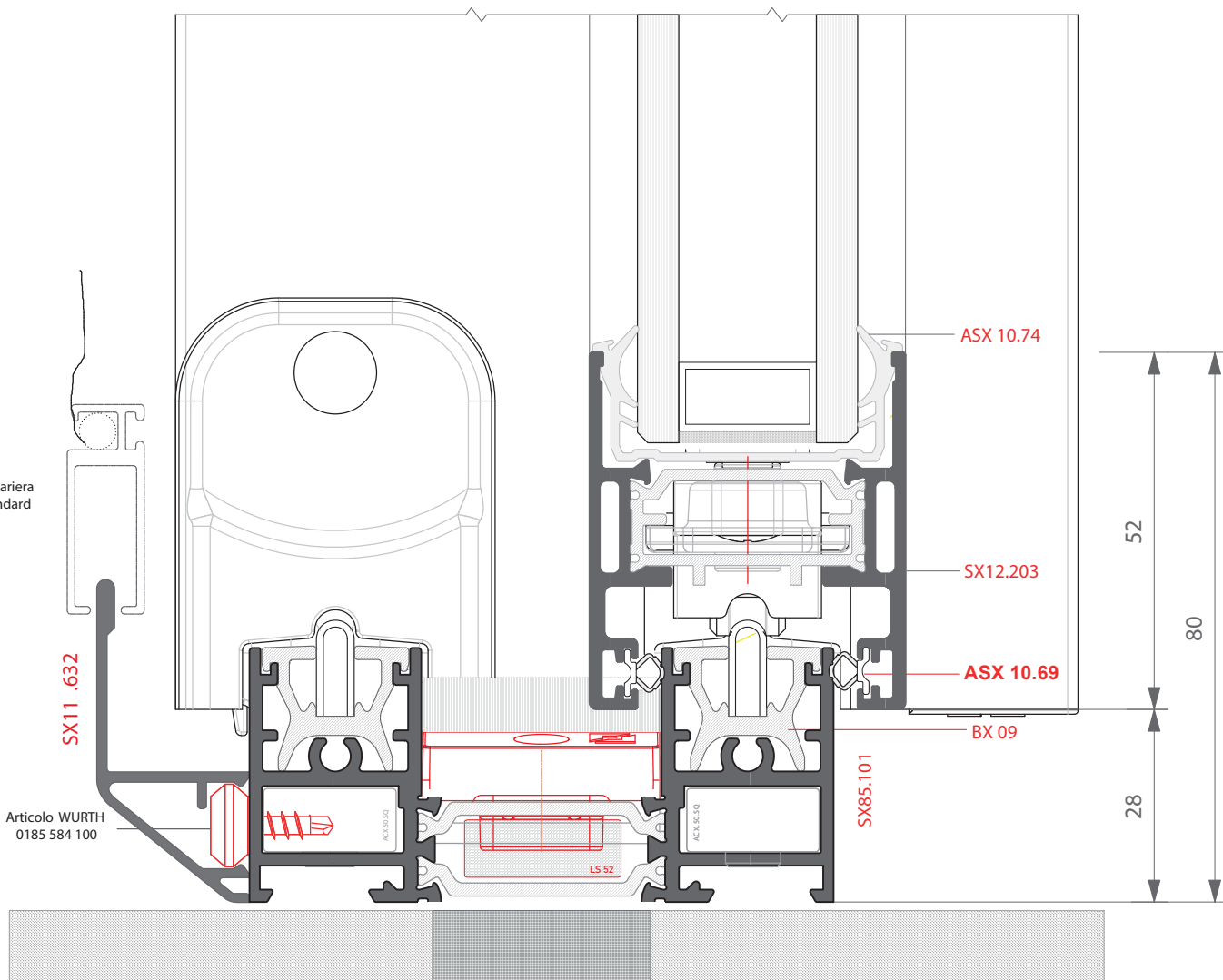



SCORREVOLE A 2 ANTE MOBILI
Inferiore Ribassato
SLIDING DOOR WITH 2 MOVABLE DOORS
Lowered Lower

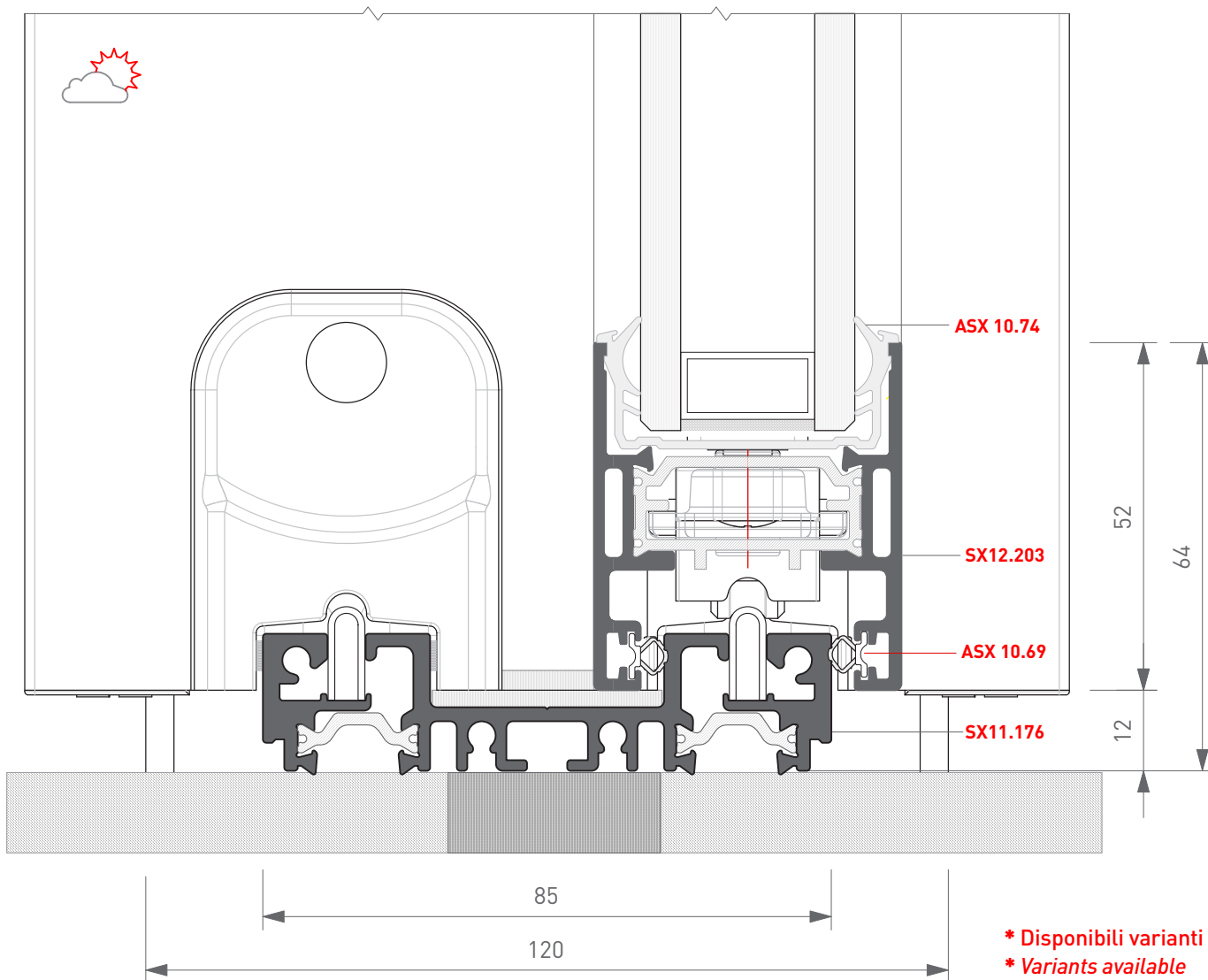
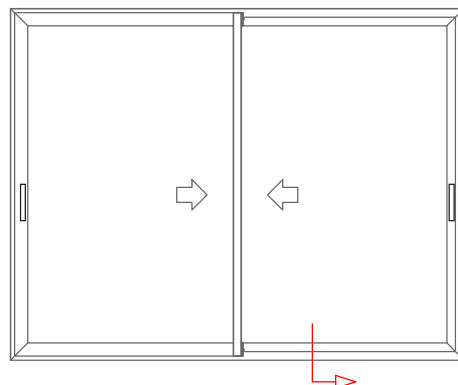

* Disponibili varianti
* Variants available



Soluzione da evitare in contesti con esposizione diretta all'acqua

Solution to avoid in contexts with direct exposure to water

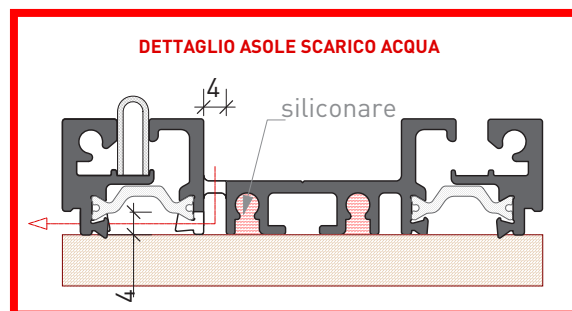



SCORREVOLE A 4 ANTE MOBILI
Centrale

SLIDING DOOR WITH 4 MOVABLE DOORS
Central

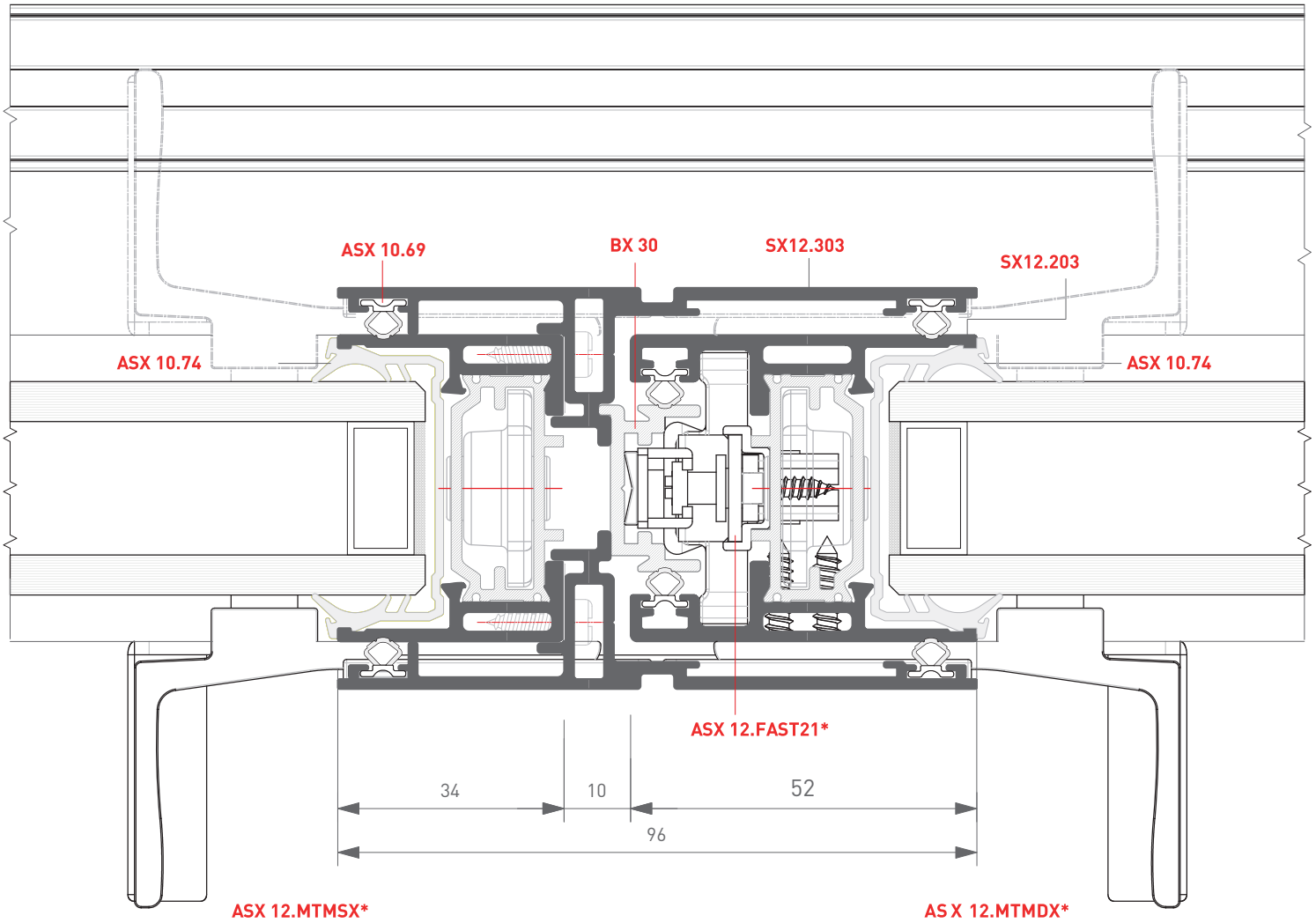
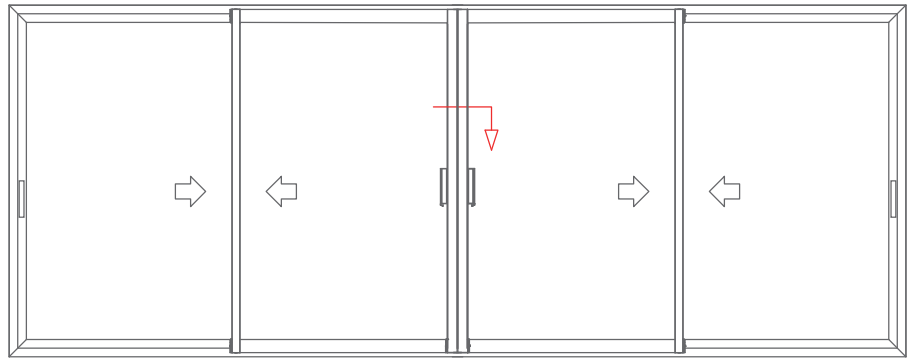

* Disponibili varianti
* Variants available



SCORREVOLE CON ANGOLO MOBILE
SLIDING DOOR WITH MOBILE CORNER

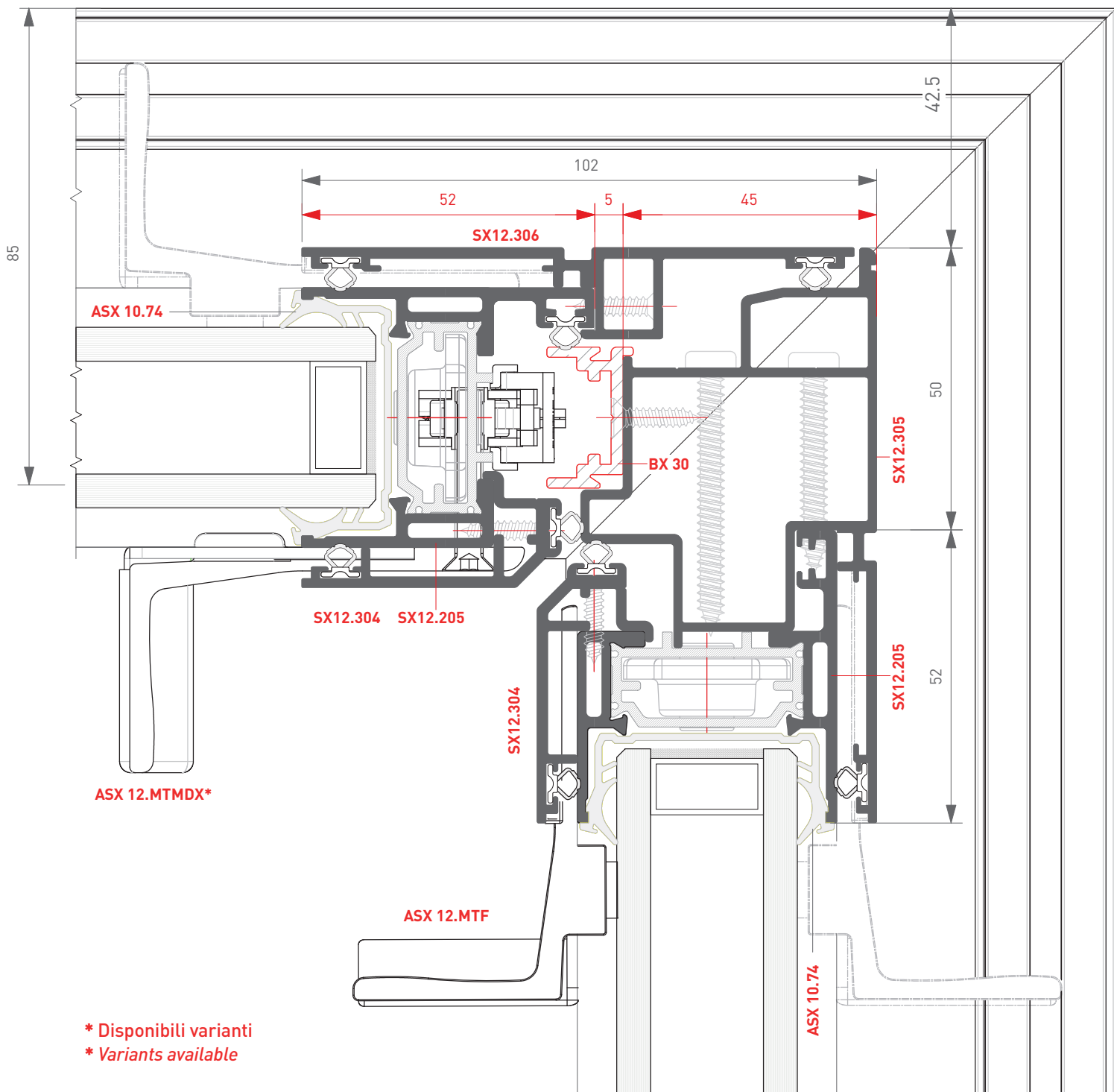
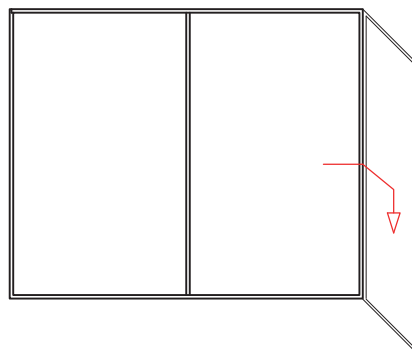

* Disponibili varianti
* Variants available



SCORREVOLE A 3 ANTE MOBILI
SLIDING DOOR WITH 3 MOVABLE DOORS

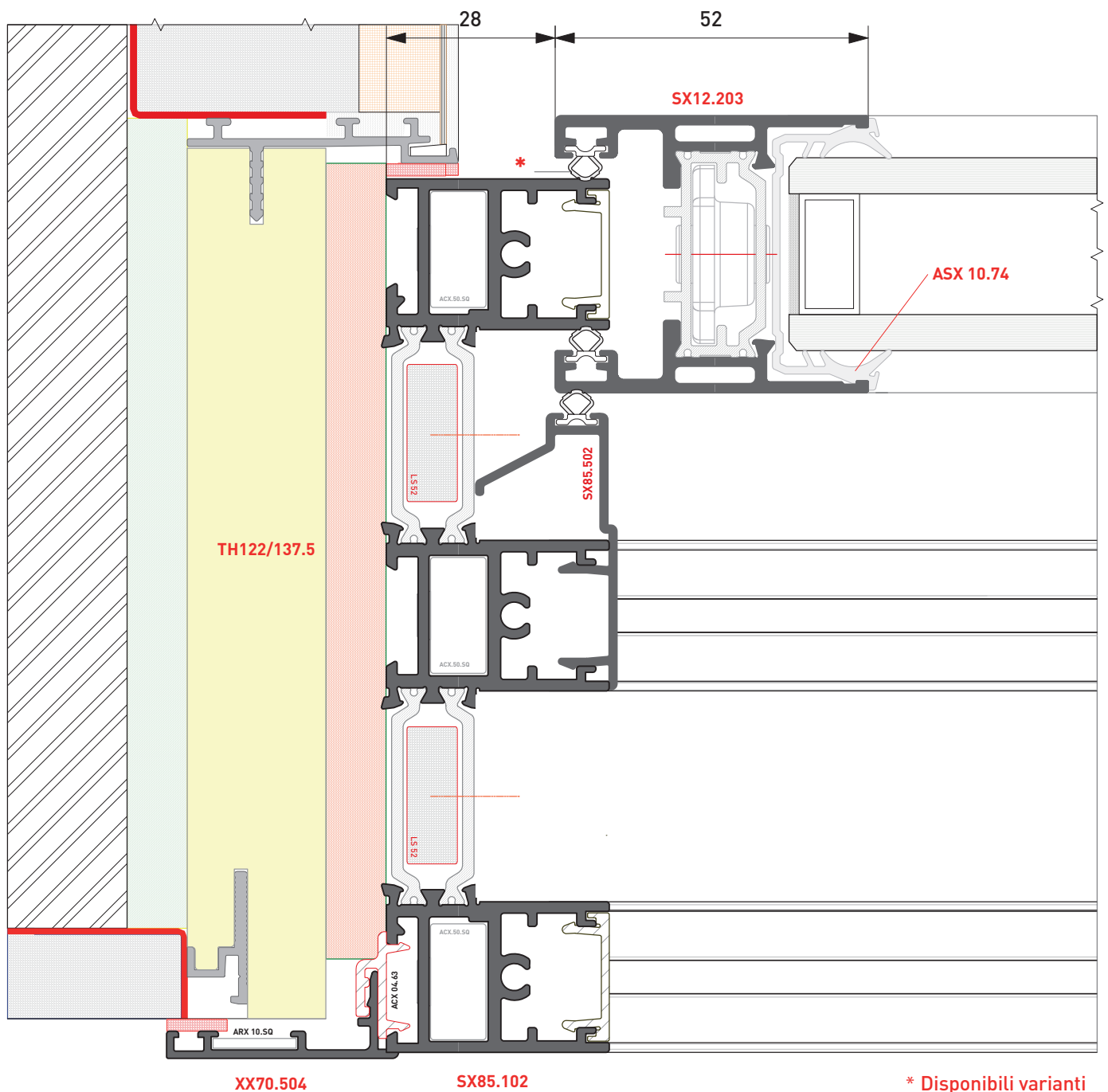
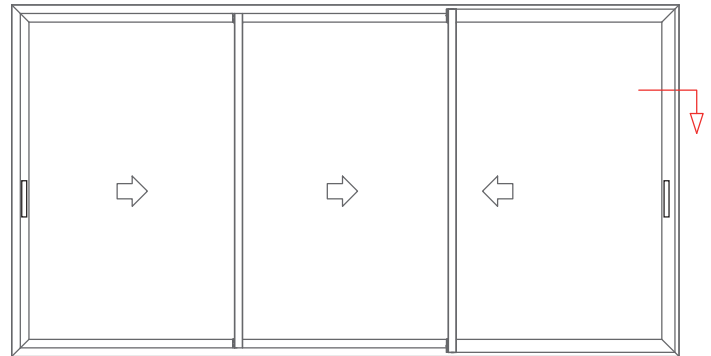

* Disponibili varianti
* Variants available



SCORREVOLE 3 ANTE MOBILI
SLIDING DOOR WITH 3 MOVABLE DOORS

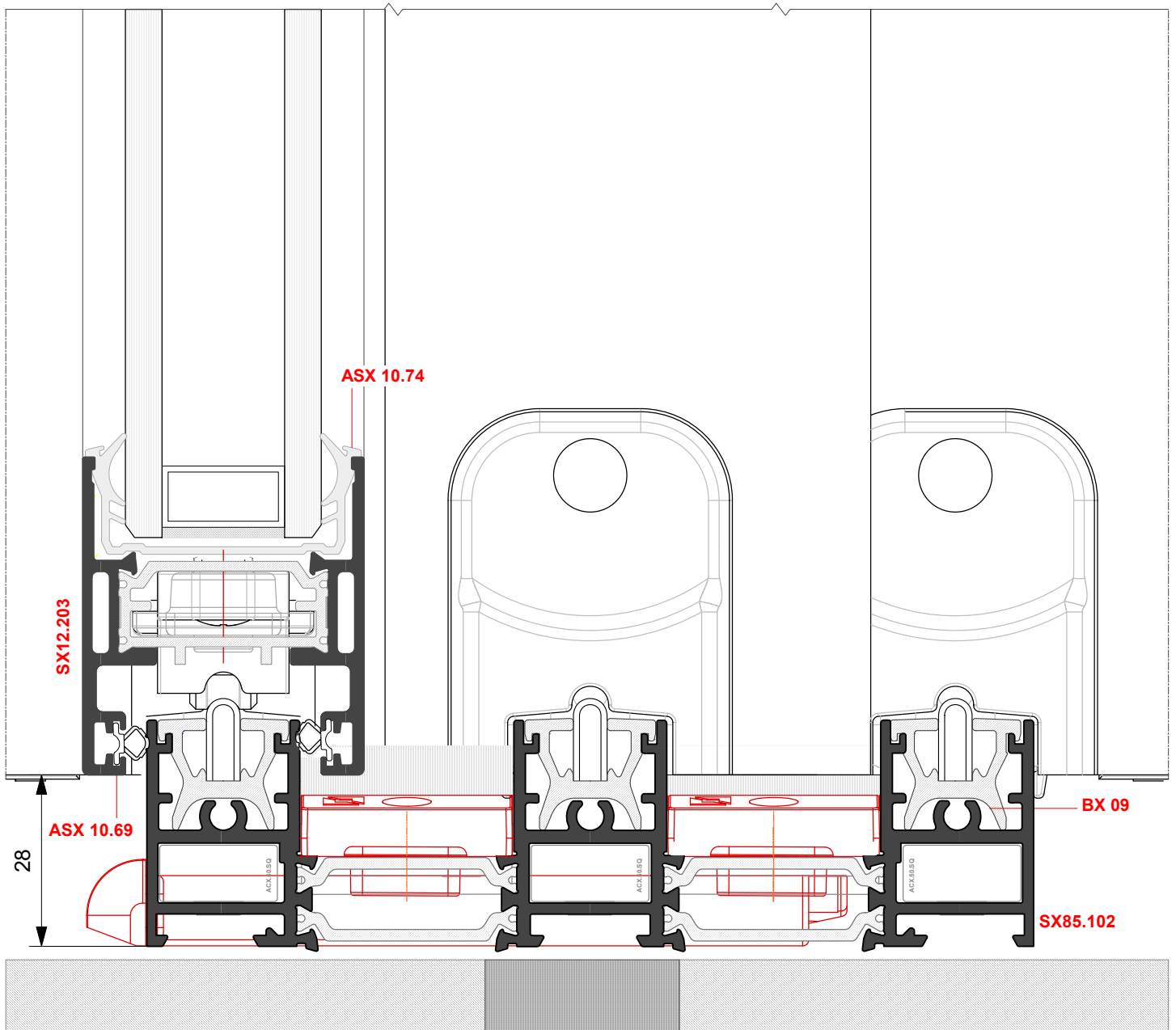
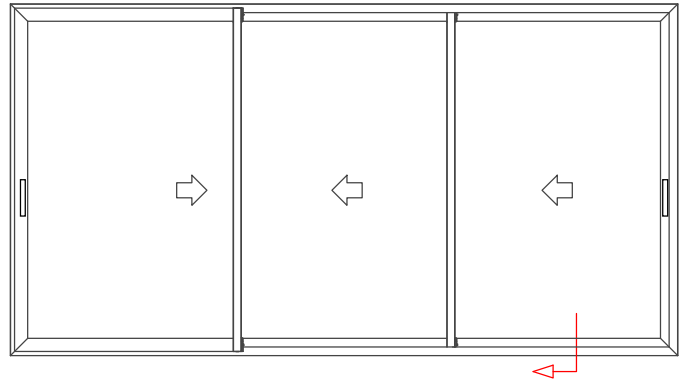

*** Disponibili varianti**



SCORREVOLE A 2 ANTE MOBILI MAGGIORATE
Laterale interno

SLIDING DOOR WITH 2 LARGE MOVABLE DOORS
Internal lateral

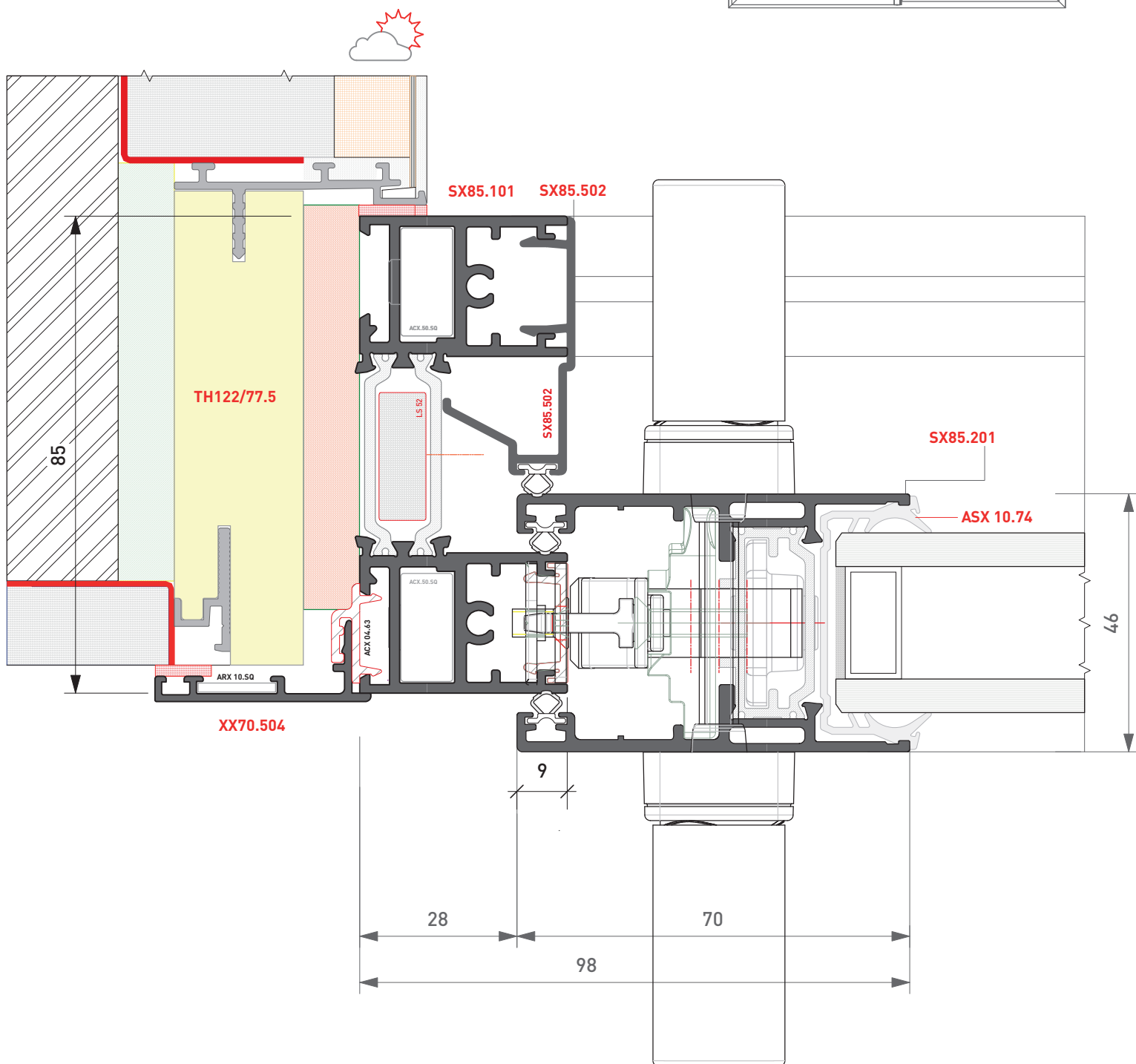
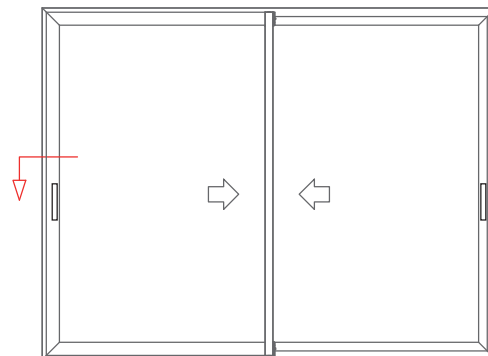



SCORREVOLE A 2 ANTE MOBILI MAGGIORATE
Laterale esterno

SLIDING DOOR WITH 2 LARGE MOVABLE DOORS
External lateral

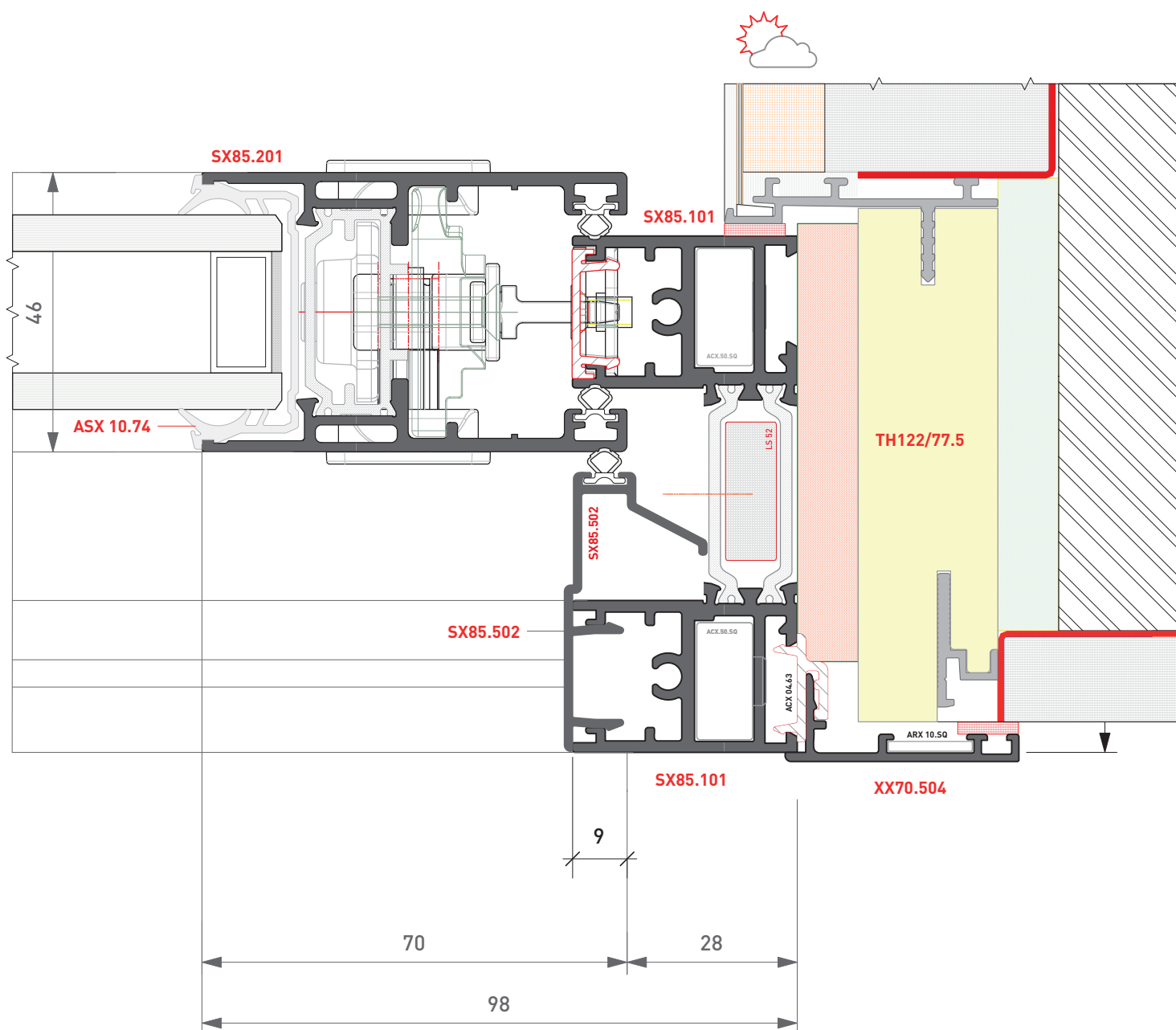
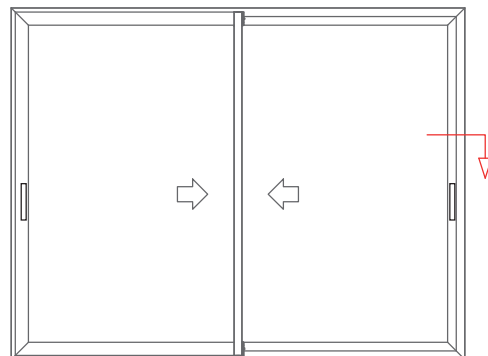



SCORREVOLE A 2 ANTE MOBILI - ALZANTE
Laterale interno

SLIDING 2 MOBILE SASHES
Internal lateral

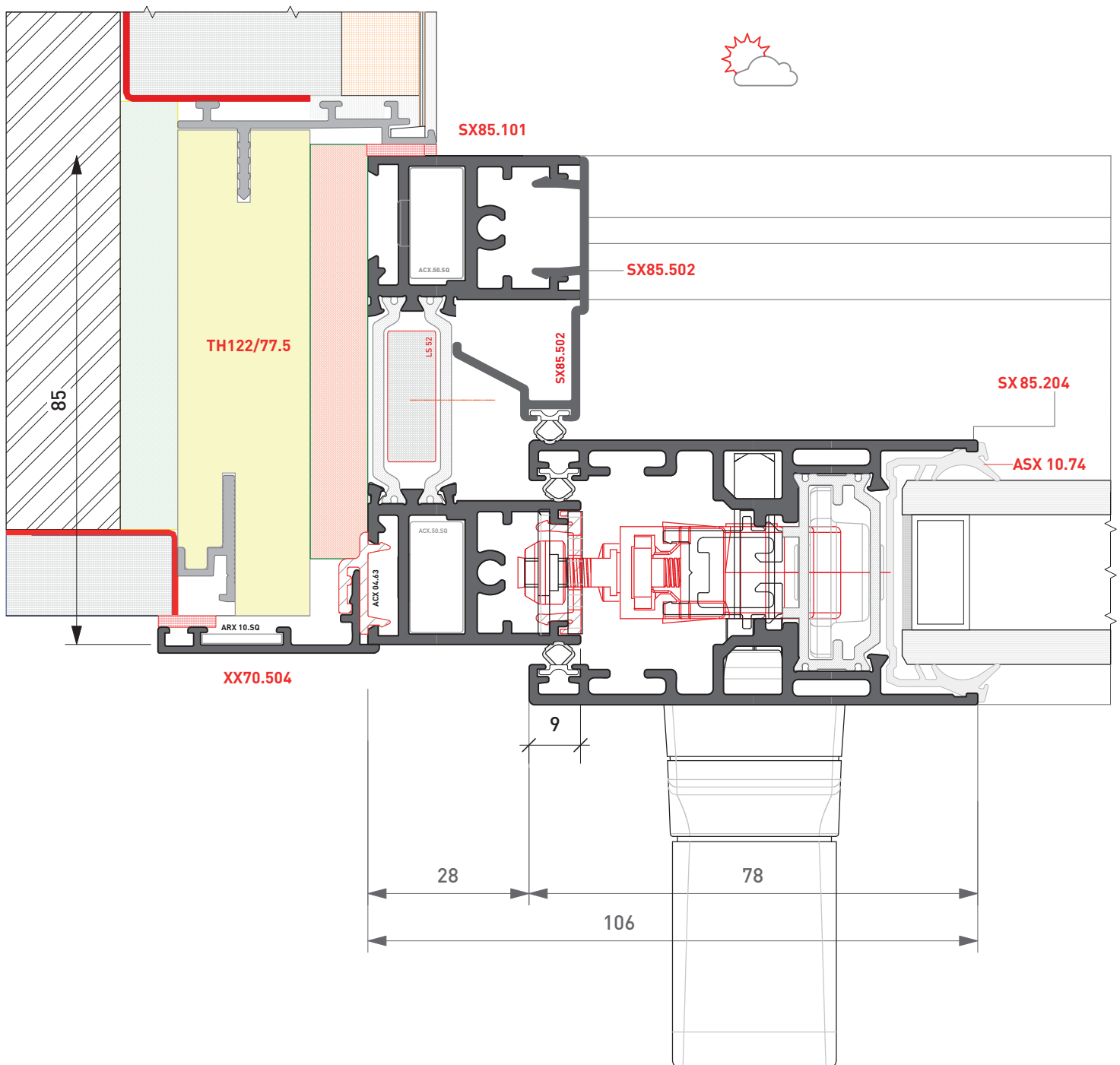
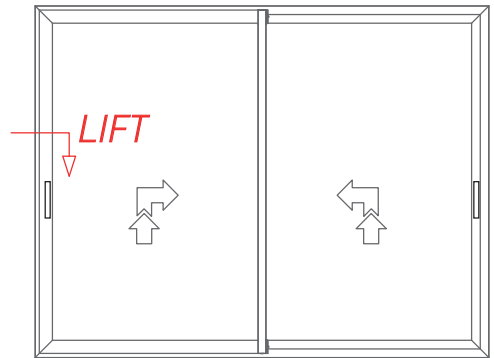



SCORREVOLE A 2 ANTE MOBILI - ALZANTE
Inferiore

SLIDING 2 MOBILE SASHES - **LIFT**
Inferior

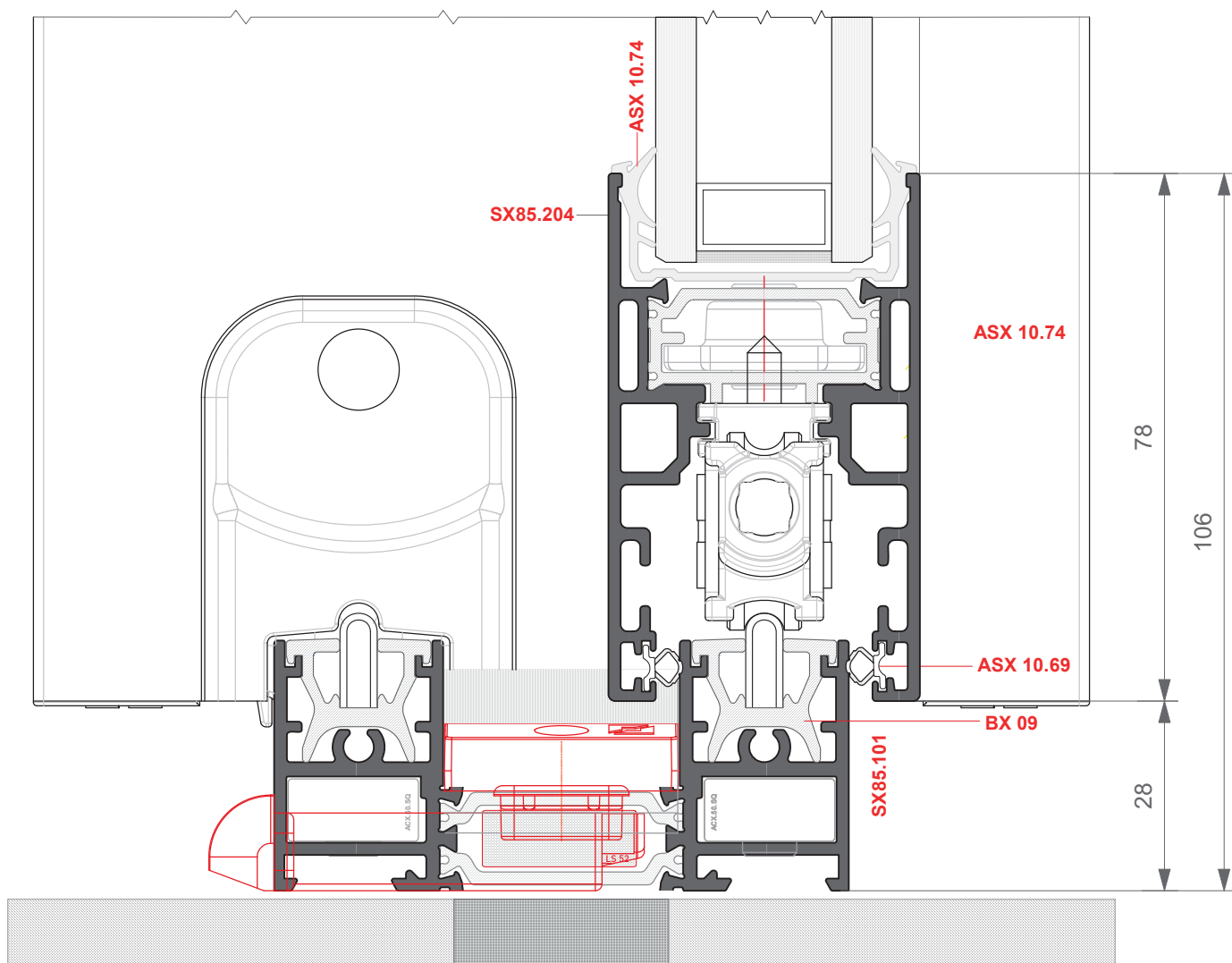
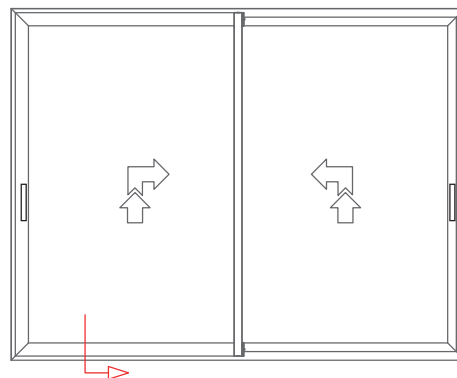

* Variante in alluminio

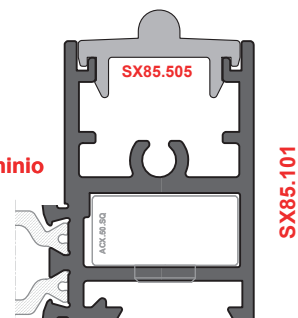



**SCORREVOLE A 2 ANTE MOBILI
CON FISSO**

SLIDING WITH 2 MOVABLE DOORS
WITH FIXED PART

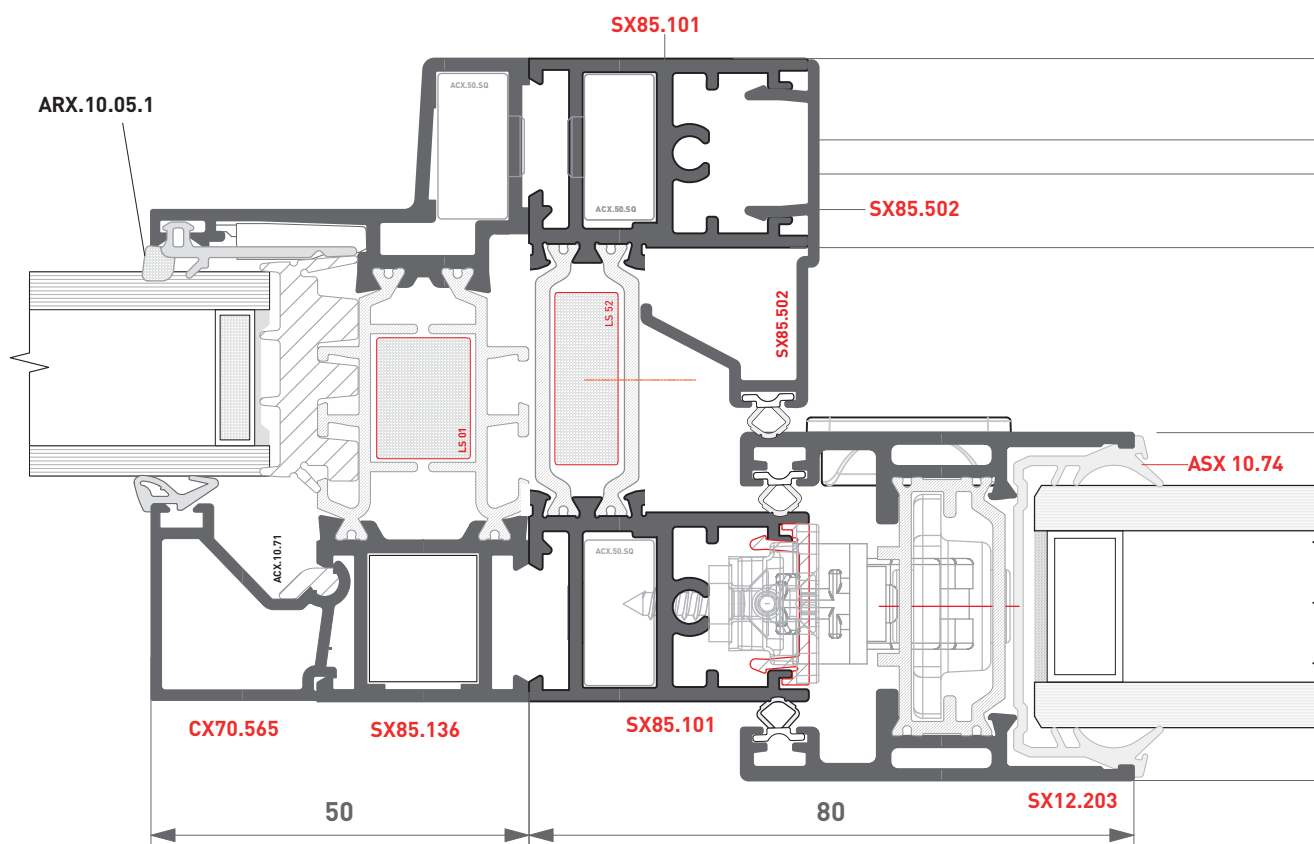
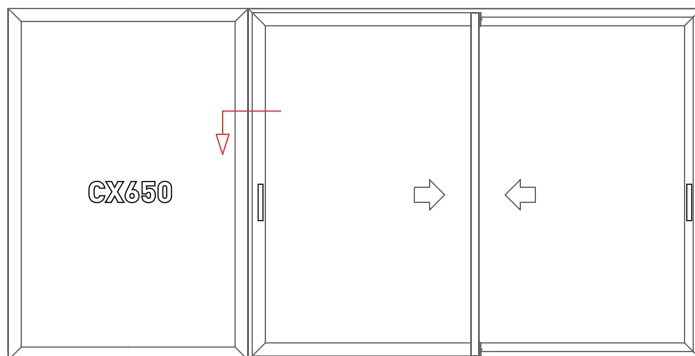

Profilo di accoppiamento SX85 e CX650
SX85 and CX650 System Coupling Profile

**Abbinamento ad inserimento
finestra scorrevole con finestra
a battente CX 650**

*Combination of sliding window
with casement window CX 650*

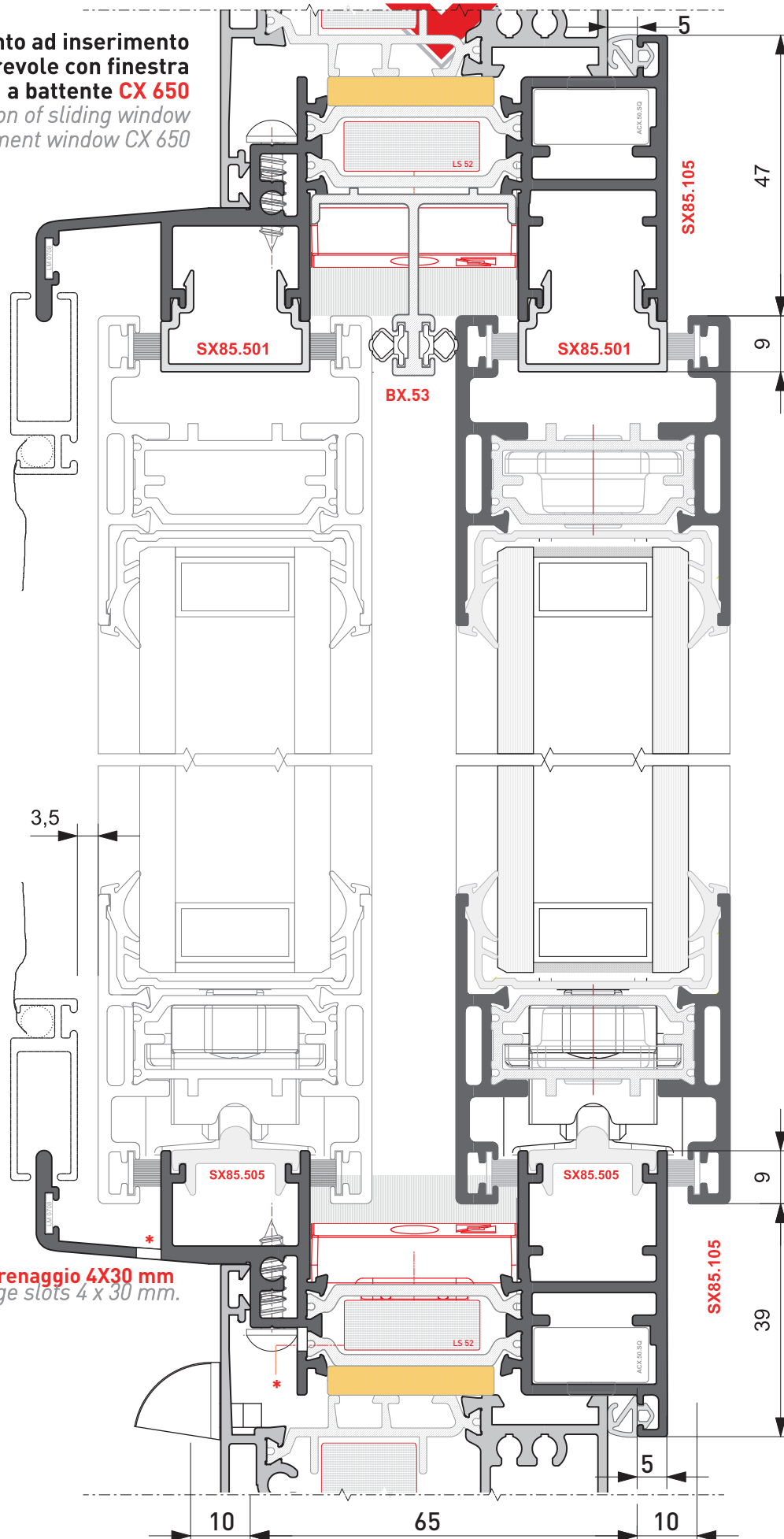

***Asole Drenaggio 4X30 mm**
Drainage slots 4 x 30 mm.

**Abbinamento ad inserimento
finestra scorrevole con finestra
a battente CX700-RX700**

*Combination of sliding window
with casement window CX-RX 700*

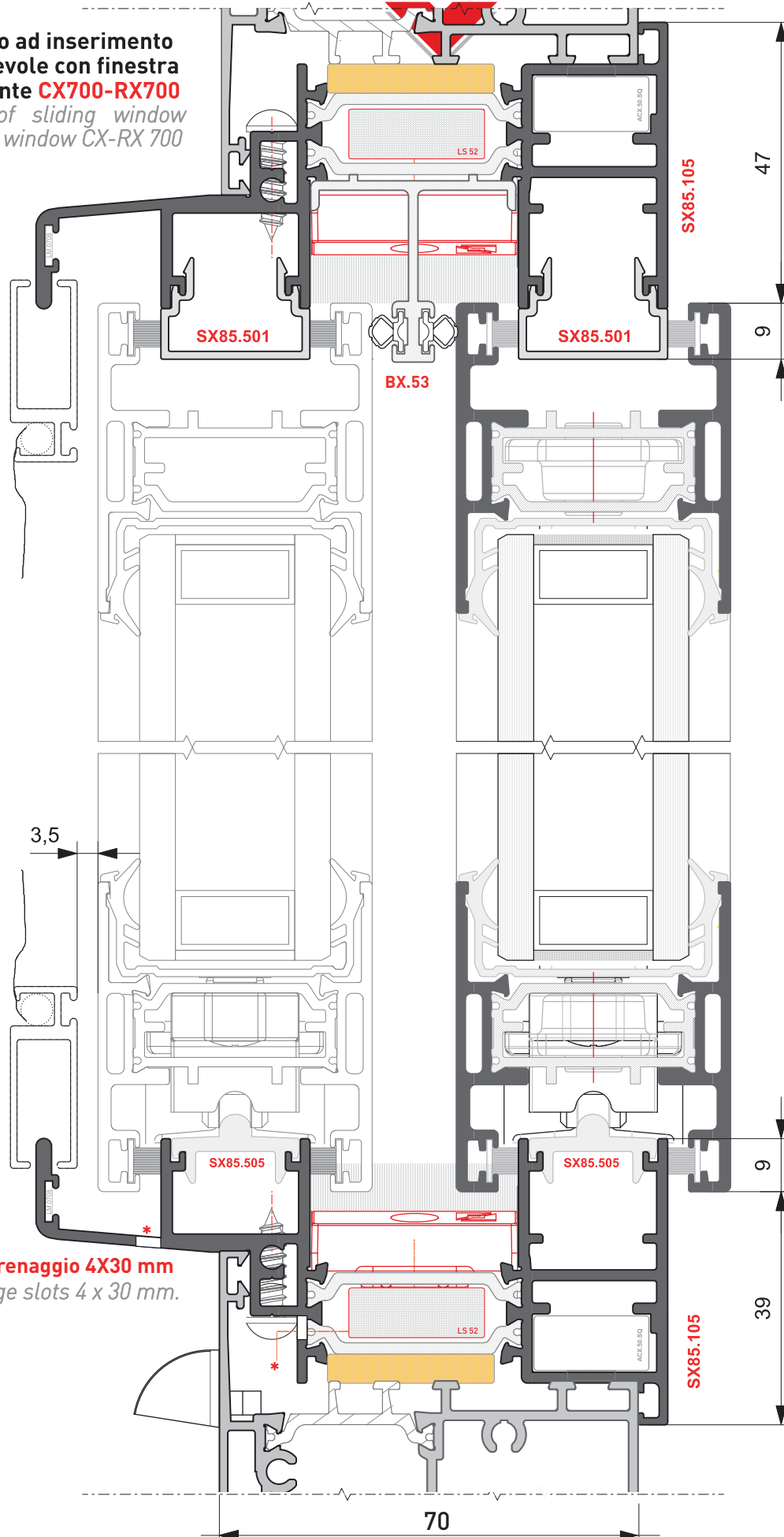

***Asole Drenaggio 4X30 mm**
Drainage slots 4 x 30 mm.



SCORREVOLE A 4 ANTE MOBILI ALZANTE
Centrale

SLIDING DOOR WITH 4 MOVABLE DOORS **LIFT-AND-SLIDE**
Central

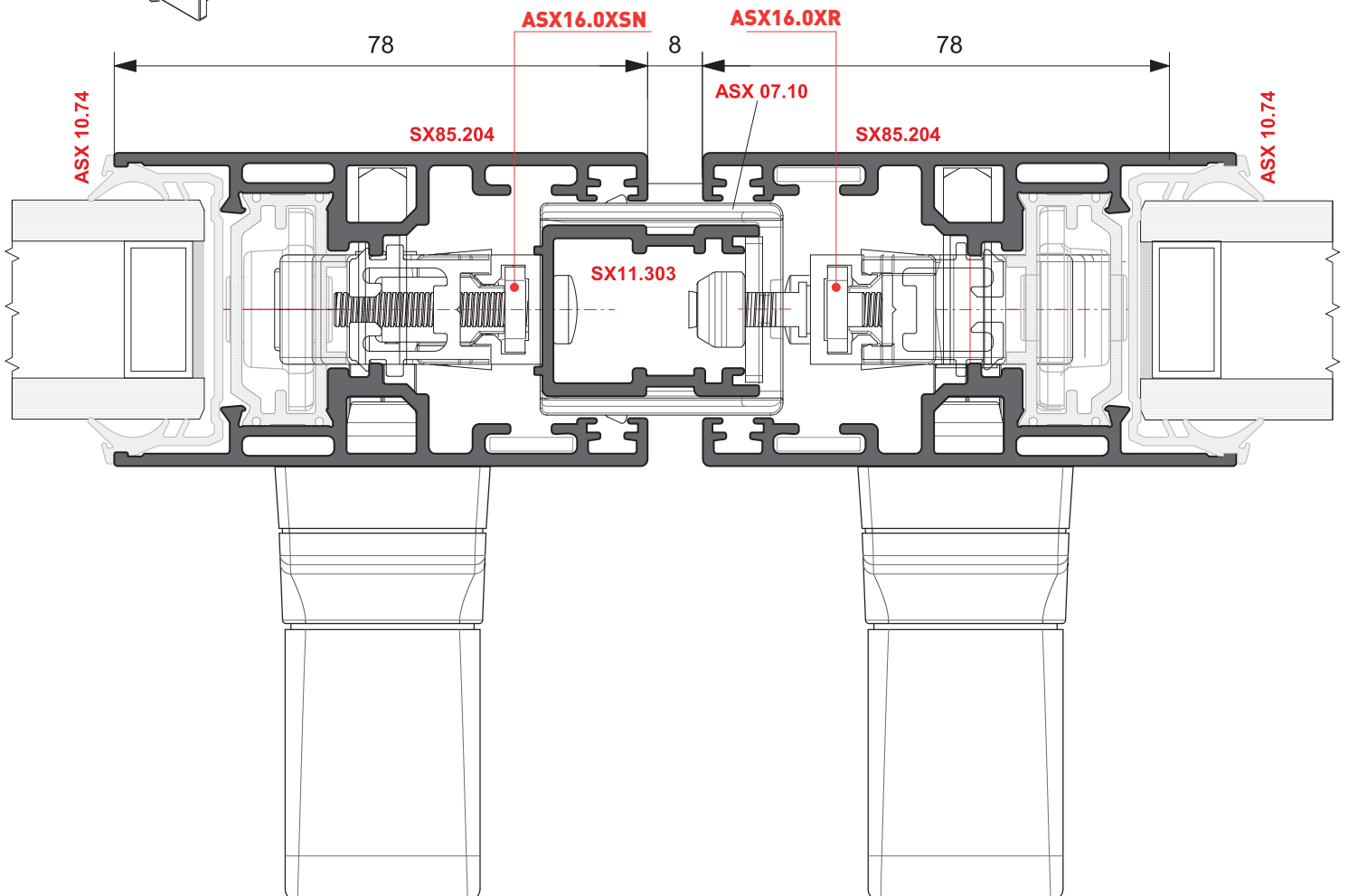
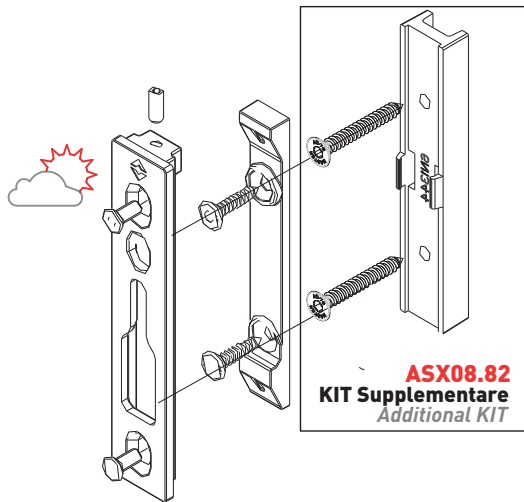
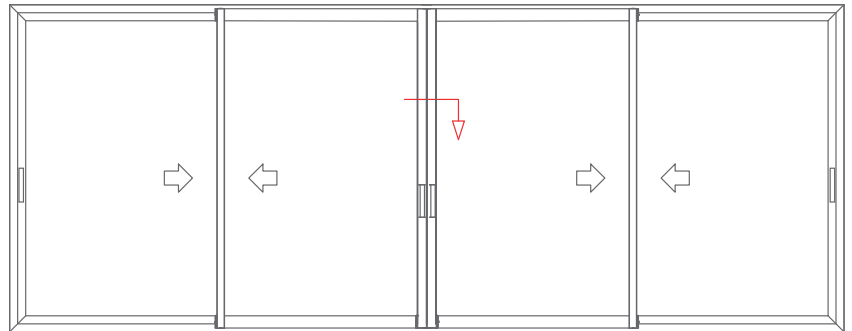



SCORREVOLE A 4 ANTE MOBILI ALZANTE
Centrale

SLIDING DOOR WITH 4 MOVABLE DOORS **LIFT-AND-SLIDE**
Central

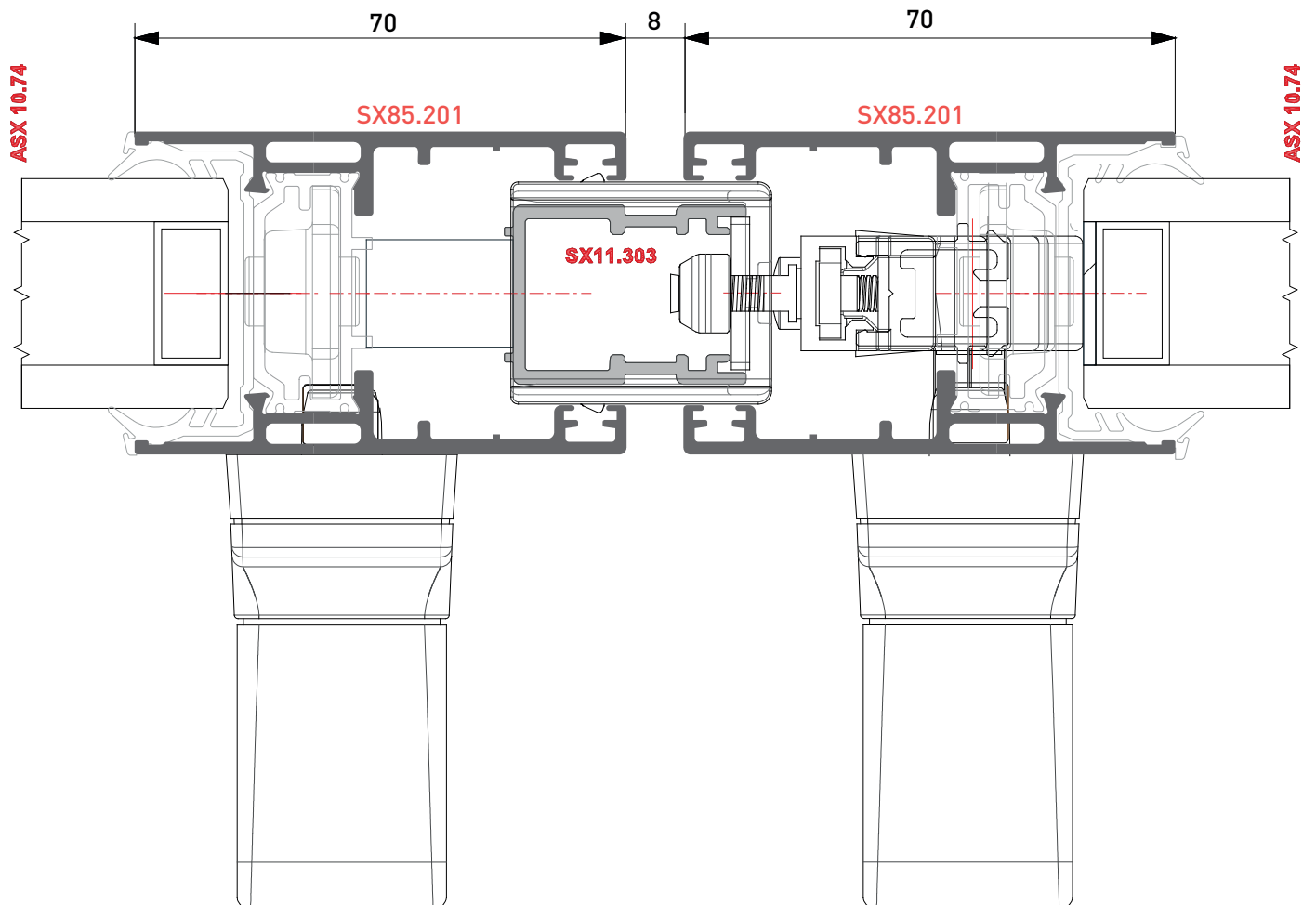
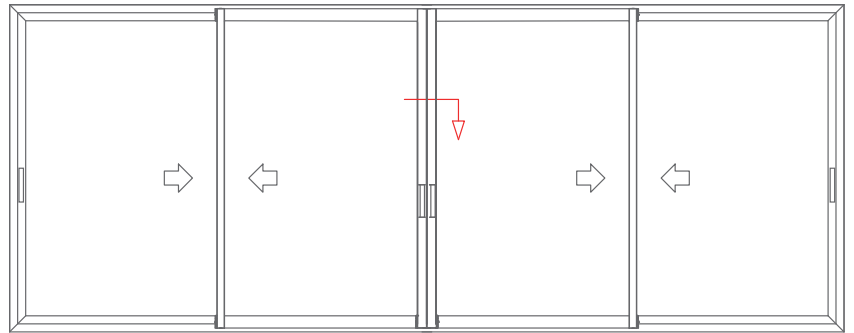
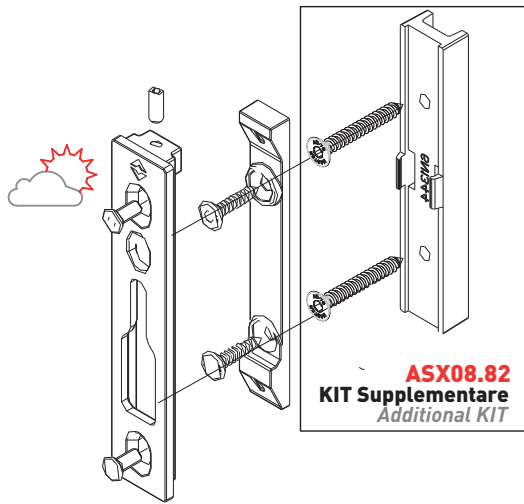



SCORREVOLE A 4 ANTE MOBILI Centrale

SLIDING DOOR WITH 4 MOVABLE DOORS Central

Variante
Version

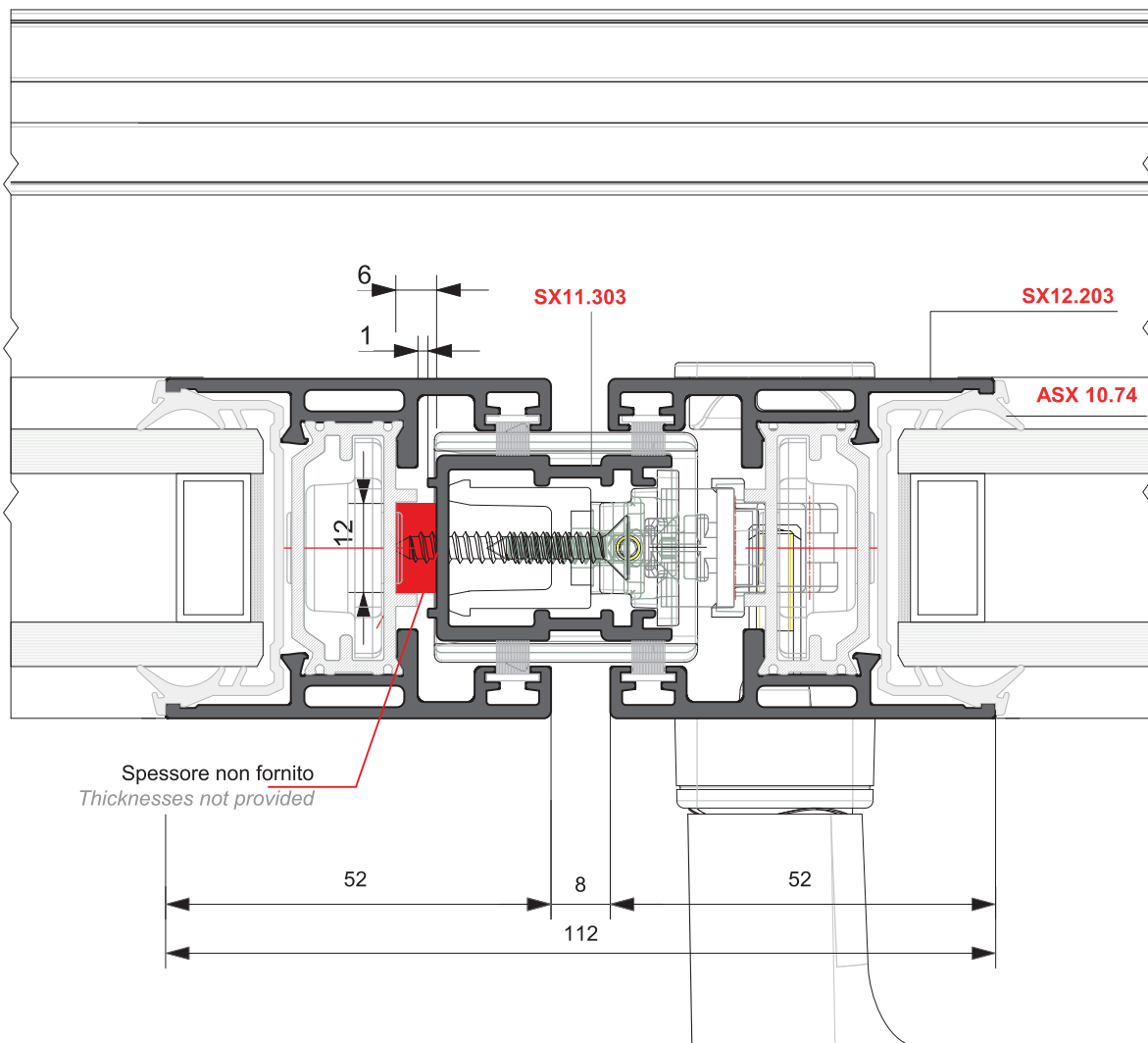
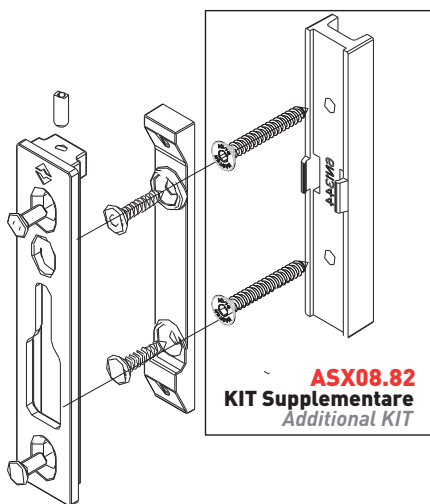
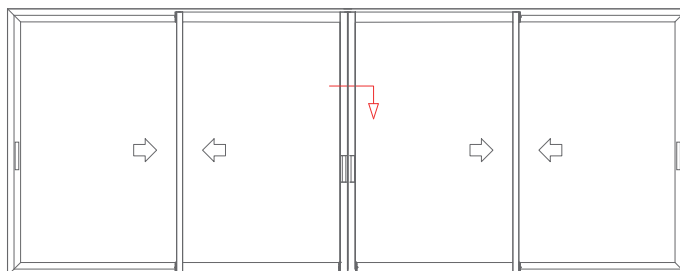



SCORREVOLE A 2 ANTE MOBILI
Soglia Filopavimento
SLIDING DOOR WITH 2 MOVABLE DOORS
Floor Level Treshold

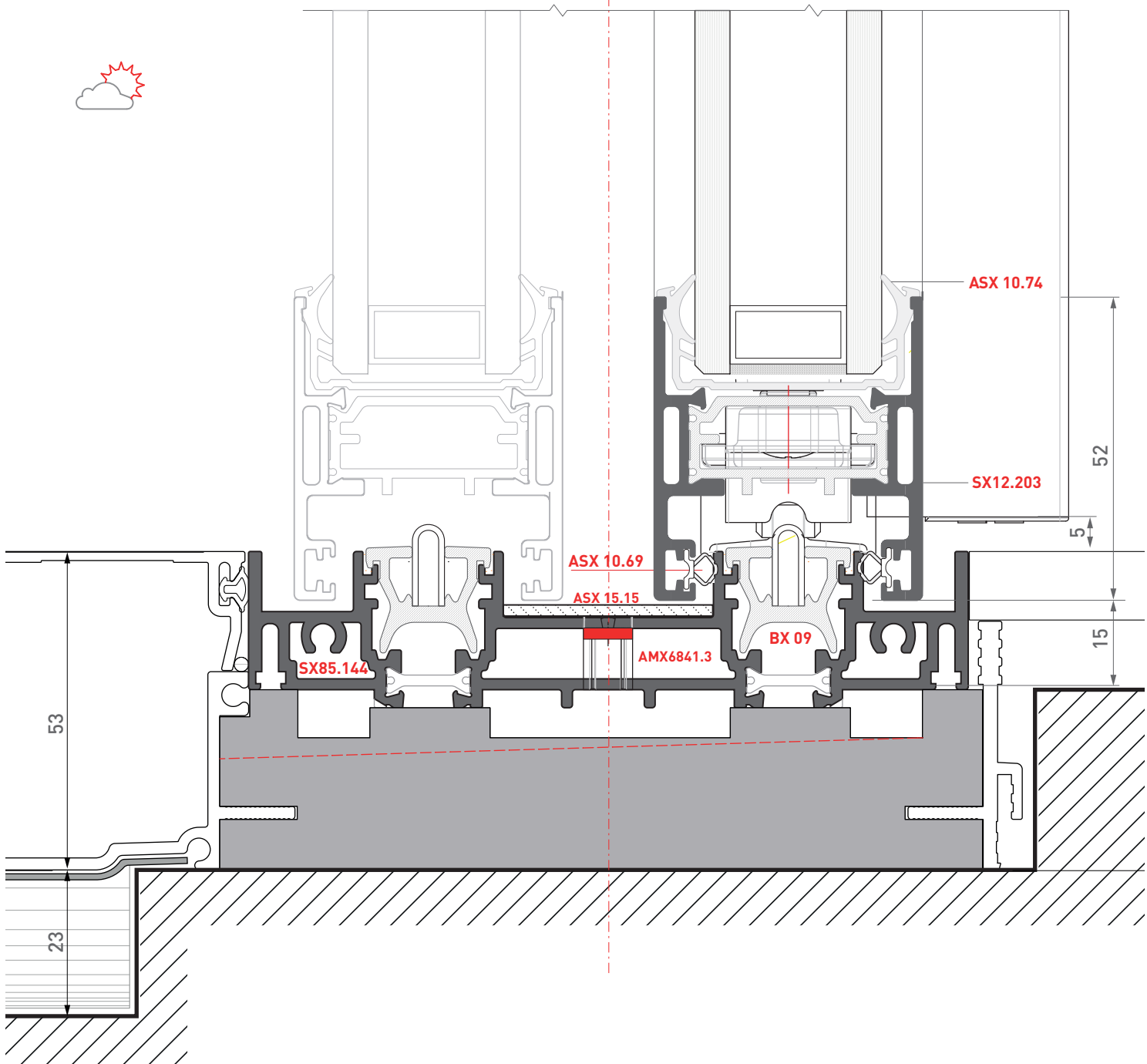
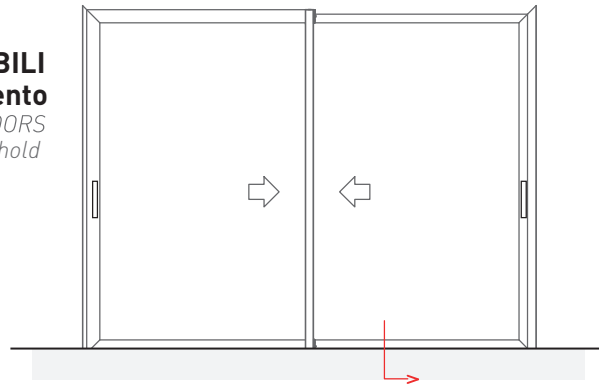





**SCORREVOLE A
SCOMPARSA**

CONCEALED SLIDING Sash

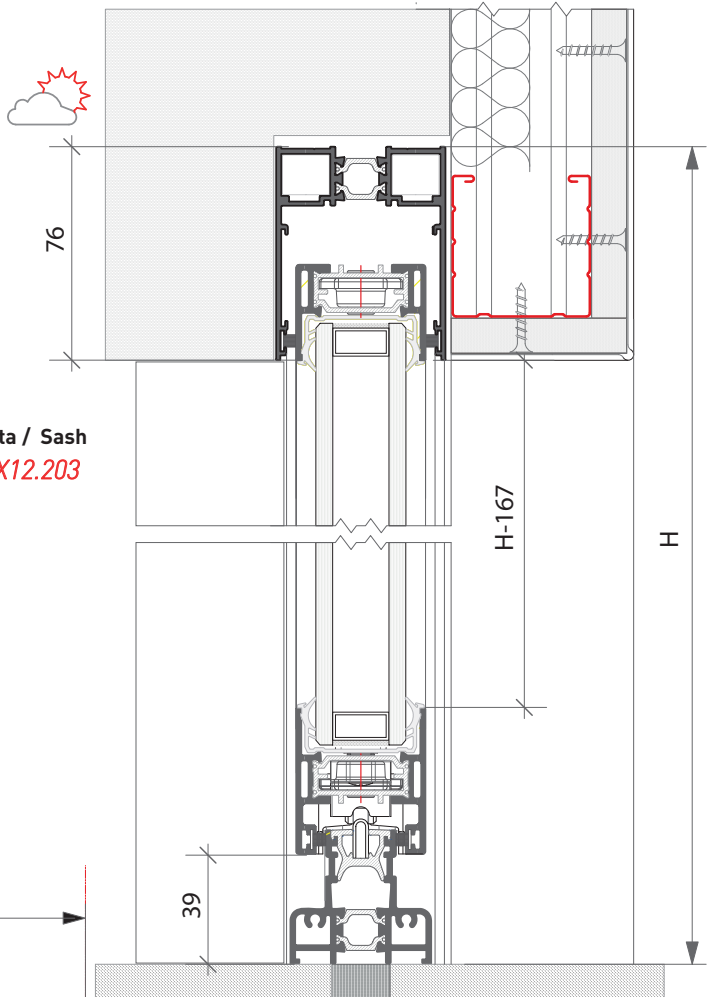

Anta / Sash
SX12.203

**Distinta di taglio vetri
Glass cutting list**

Q.tà	H	L
1	H - 139	L/2 - 66

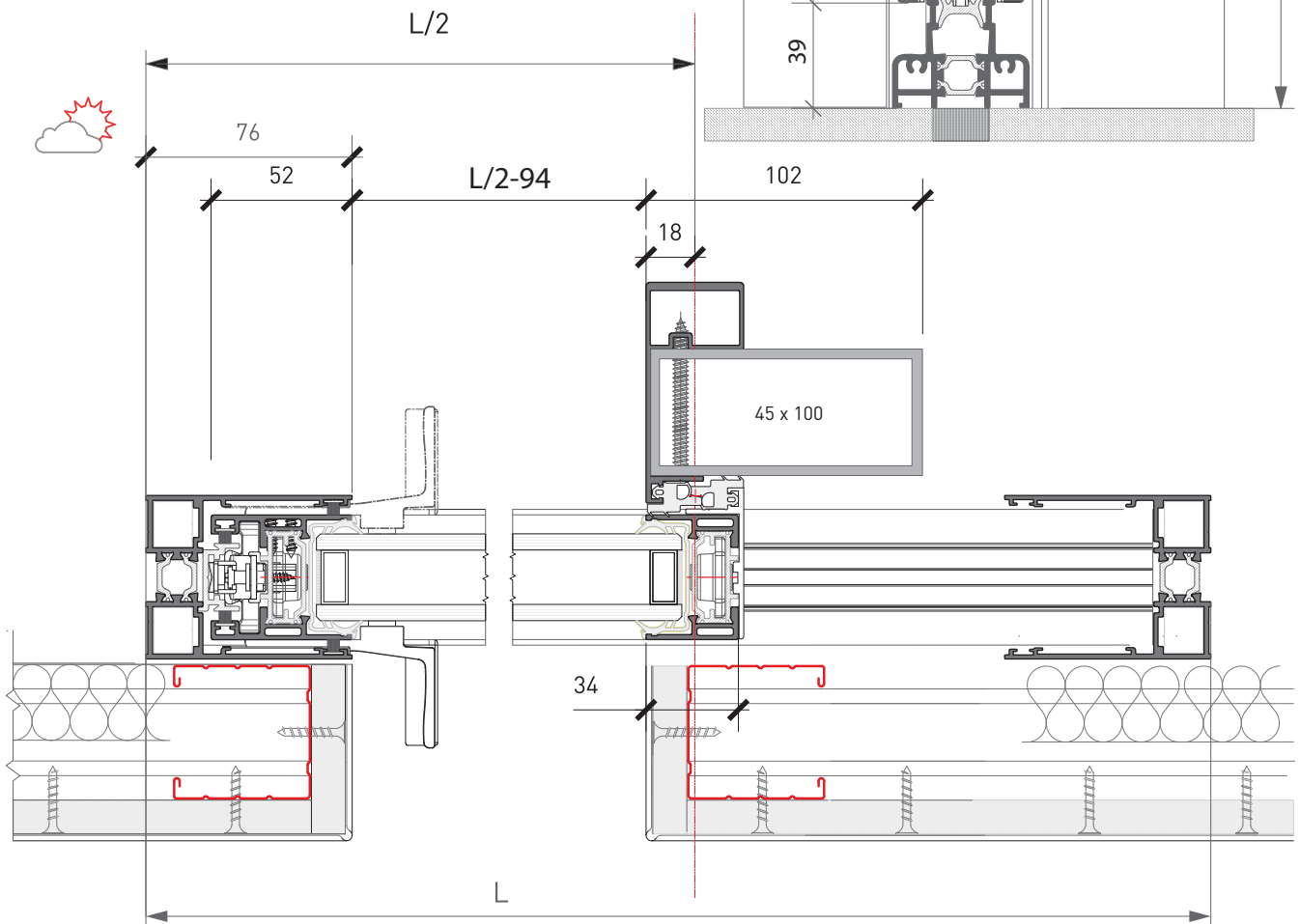
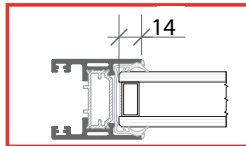



SCORREVOLE A SCOMPARSA

CONCEALED SLIDING DOOR

Distinta di Taglio | *Cutting List*

Profilo Profile	Taglio CUT	Qt.
SX11.154 	L - 42	1
ASX15.02 	L - 45	1
BX.09 	L - 42	1
SX12.153 	H	1
	H	1
	L	1
BX.30 	H - 72	1
SX12.308 	H - 81	1
SX12.203 	L/2 + 10	1
	H - 63	1
ASX10.74 	L/2 + 10	1
	H - 63	1
SX12.204 	L/2 - 26	1
	H - 99	1
ASX10.74 	L/2 - 26	1
	H - 99	1
SX12.301 	H - 76	1
	Considerare anche SX12.204 per fissaggio <i>Also consider SX12.204 for fixing</i>	
ASX10.72 		2H
ASX10.34 o ASX10.69		4H+4L

Distinta Accessori | *Accessories List*

N° 1 **ASX 12.K1AM**
Mobile - 240Kg anta
Mobile - 240Kg Sash

Non usare su anta a scomparsa
Do not use on concealed sliding

<p>ASX 12.MTMSX N° 1 KIT maniglia SX N° 1 SX Handle KIT</p> <p>Solo 1 maniglia Fisso + Mobile</p>	<p>ASX 12.FAST21Z N° 1 KIT FASTLOCK 210mm.</p>	<p>* ARX 06.01 * Secondo Dimensioni Registro Universale * According to Size Universal Registry</p>
<p>ASX 12.BLMT N° 1 Basetta maniglia lat. N° 1 Side handle base</p>		
<p>ASX 12.MTF 1 Pz. Maniglia traino fissa 1 Pc. FIXED train handle</p>		



SCORREVOLE A 2 ANTE
SLIDING Sash WITH 2 DOORS

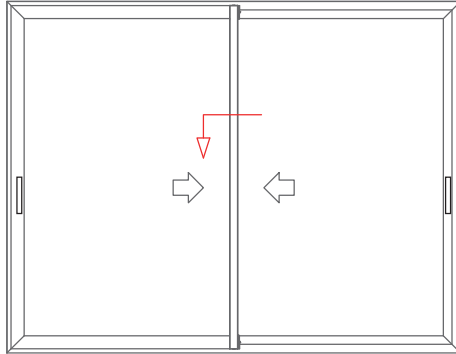

Anta / Sash
SX12.203

Distinta di taglio vetri Glass cutting list		
Q.tà	H	L
2	H - 141	L/2 - 70

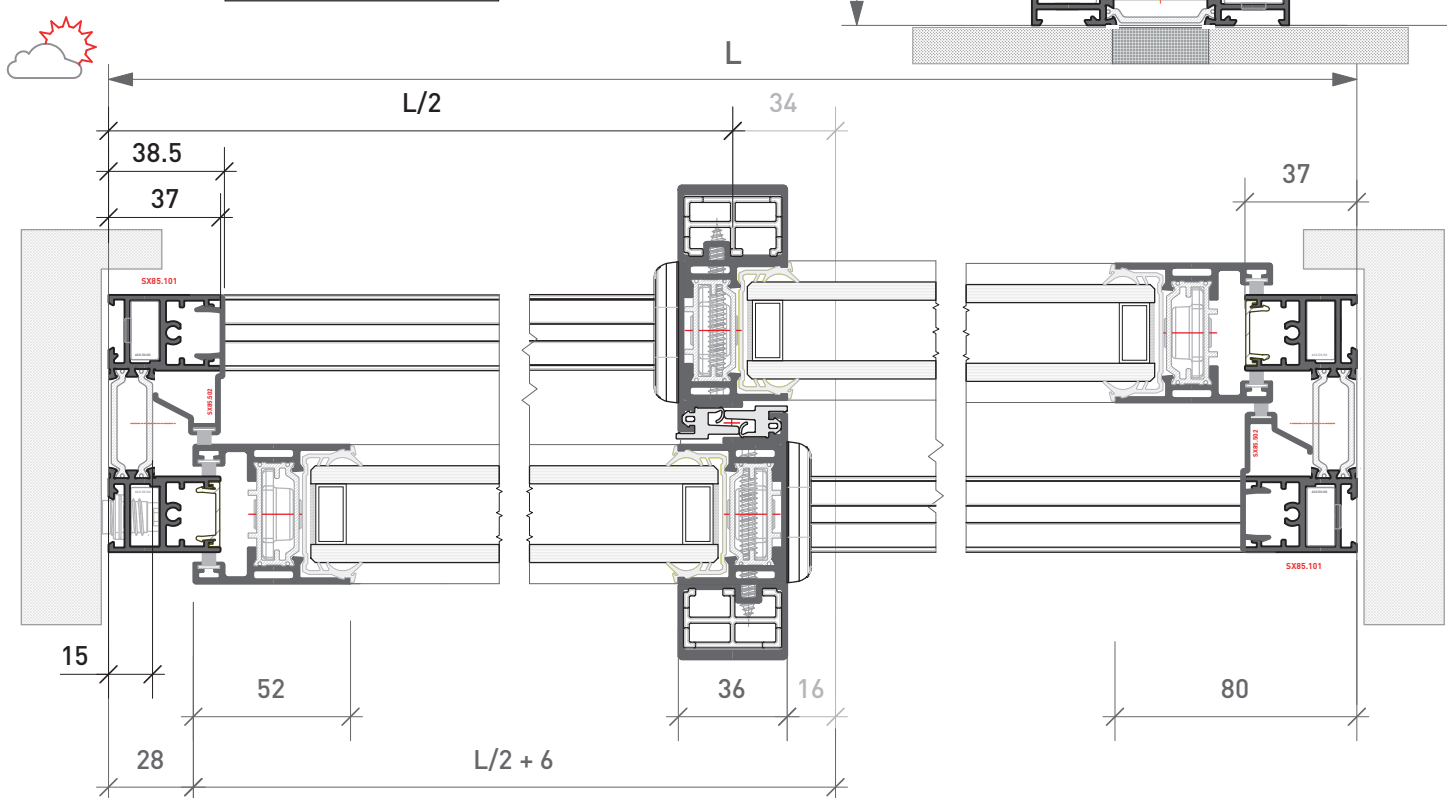
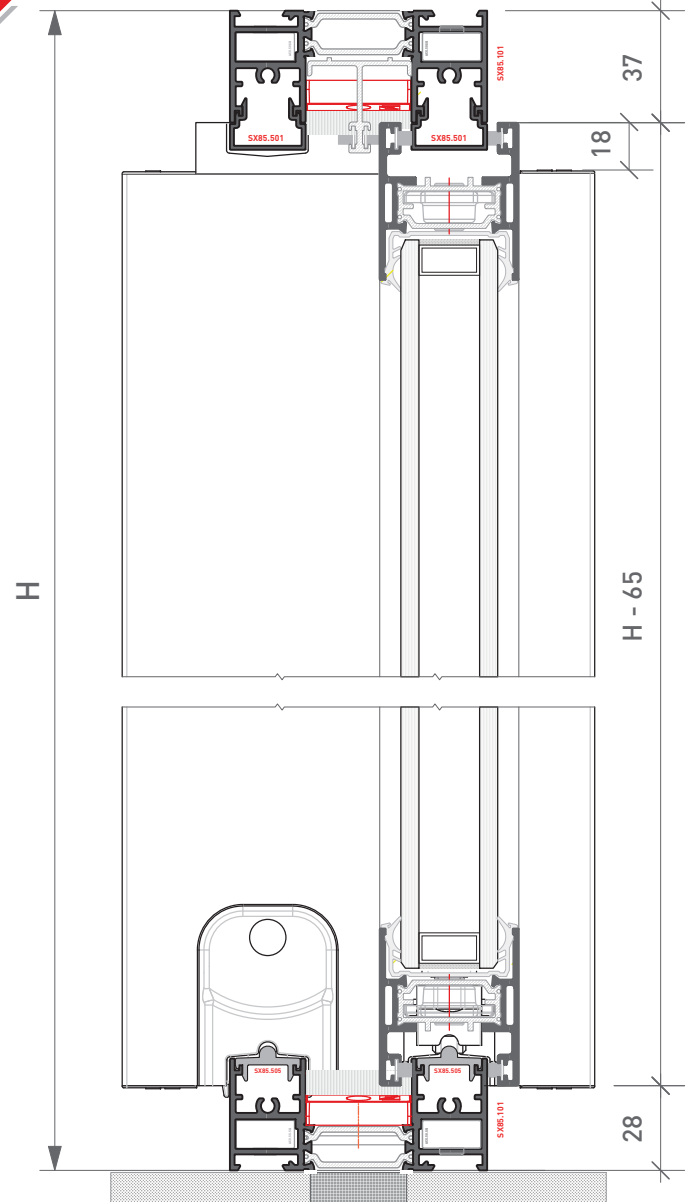
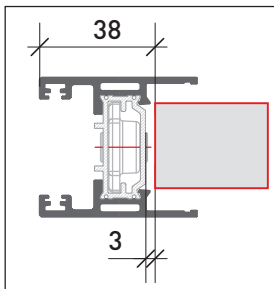









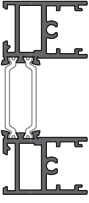



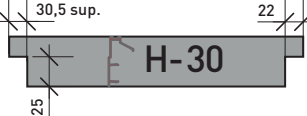

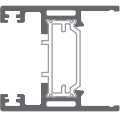
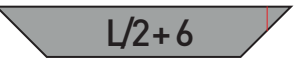

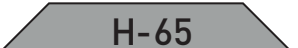
SCORREVOLE A 2 ANTE

SLIDING Sash WITH 2 DOORS



Distinta di Taglio | Cutting List

Profilo <i>Profile</i>	Taglio <i>CUT</i>	Qt.
		2
		2
SX85.101		
		2
SX85.502		
		2
SX85.505		
		4
		2
SX12.203		
		2
SX12.204		
		2
SX12.301		
		2
SX85.501		
		2
BX 53		

Guarnizioni

ASX 10.74	Guarn. vetro inserire mm.32 <i>Gasket for glass mm. 32</i>	4H+2L
ASX 10.72	Guarnizione profilo centrale <i>Central profile gasket</i>	2H
ASX 10.34 o ASX 10.69	Guarnizione tenuta anta <i>Sealing gasket Sash</i>	6H+6L
ASX 10.26	Barretta coprirotaia <i>Rail cover bar</i>	2H

Distinta Accessori | Accessories List

N° 1 ASX 85.K2AM
Kit Mobile + Mobile
2 Sliding Sashes kit

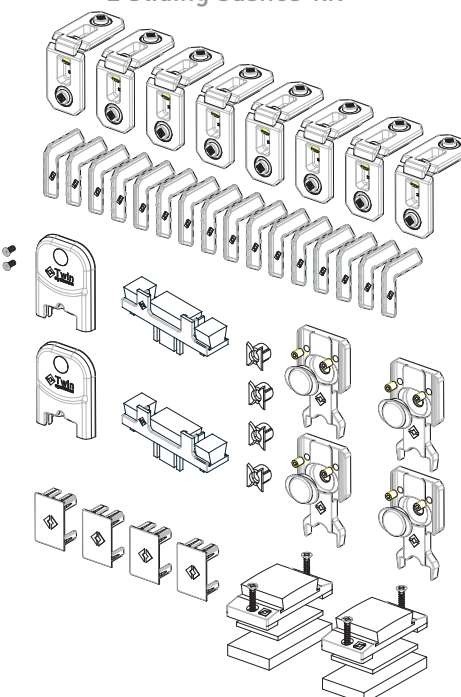

N° 2 ASX 85.CAR
Coppia carrello bilanciato regist.
240 Kg anta
Balanced adjustable roller 240 Kg Sash

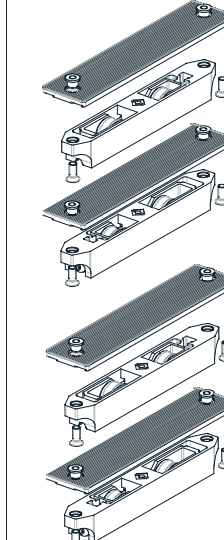

ACX 50.SQ
N° 8
Squadretta telaio
Corner joint frame

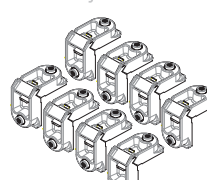

ASX 12.FAST60
N° 2 Kit
Fastlock 600 mm.

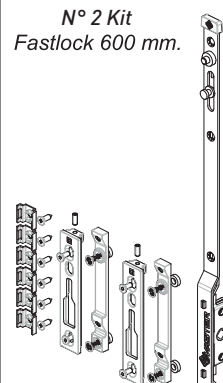

*** ARX 06.01**
Registro telaio
Frame adjuster



* Quantità secondo dimensioni
Quantity according to dimensions

ACX.08.71 SX

N° 1
Martellina SX disassata
Offset handle

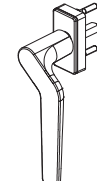

**

ASX 12.VASCH
Vaschetta drenaggio
Drainage system

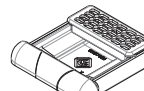

* Quantità secondo dimensioni
Quantity according to dimensions

ASX 12.FAST100
N° 2 Kit
Fastlock 1000 mm.

ASX 12.FAST180
N° 2 Kit
Fastlock 1800 mm.

Anta fissa-Fixed Sash
ASX12.ANGFIS



Solo Fisso c/ Mobile
Only fixed Sash w/Mobile Sash

**** Secondo preferenza - As per Choice**



SCORREVOLE A 2 ANTE
Soglia Ribassata

SLIDING Sash WITH 2 DOORS
Lowered threshold

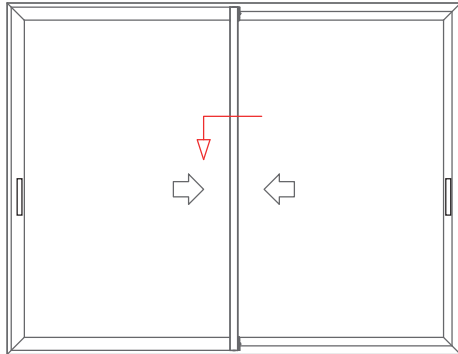

Anta / Sash
SX12.203

Distinta di taglio vetri
Glass cutting list

Q.tà	H	L
2	H - 125	L/2 - 70

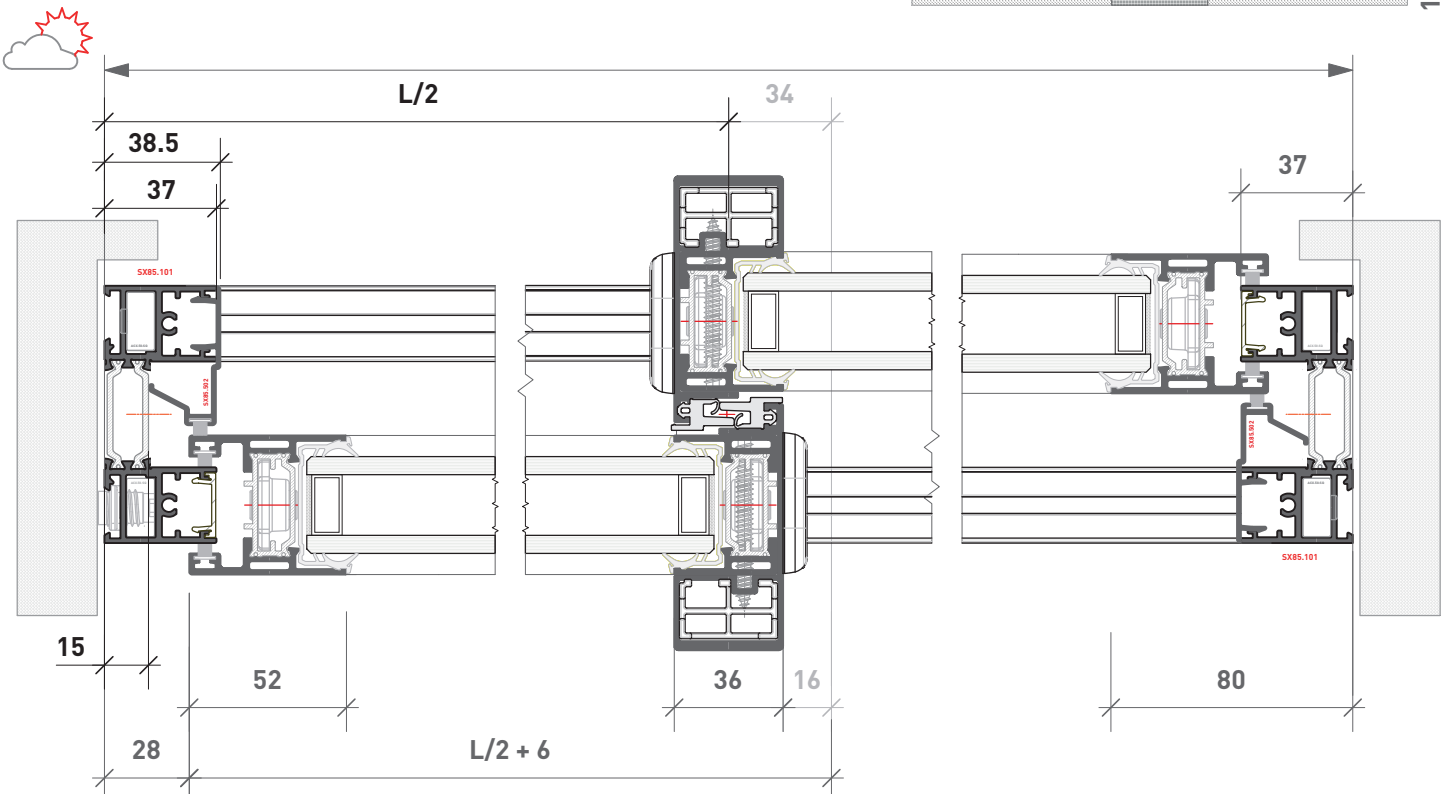
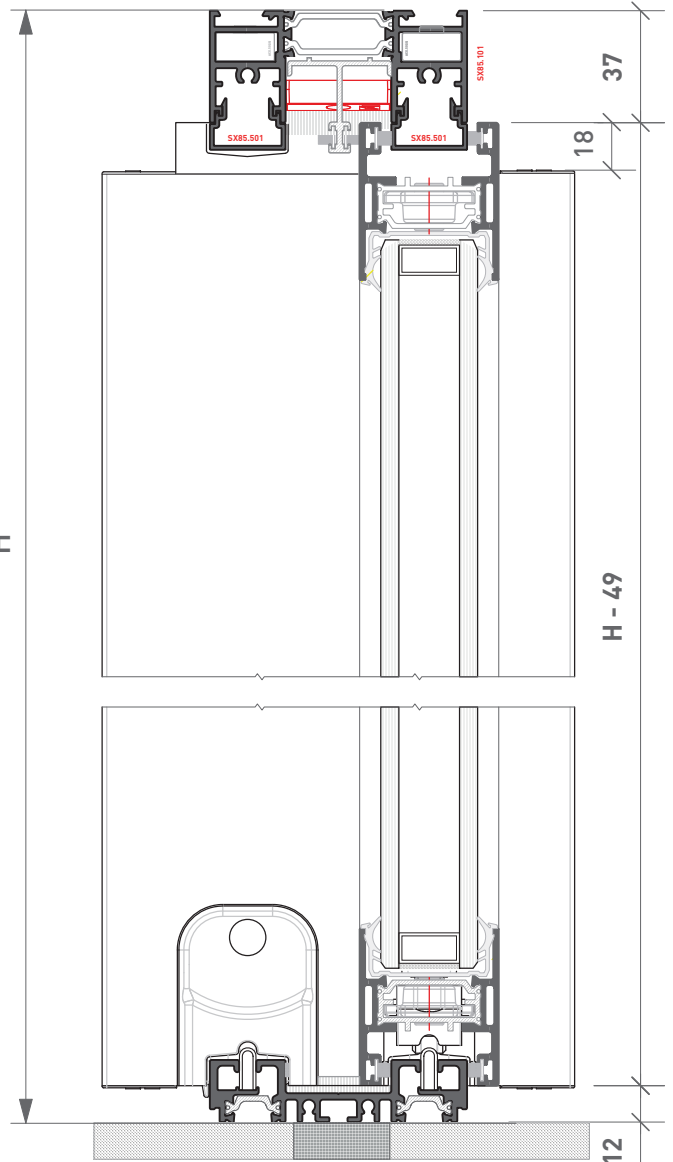
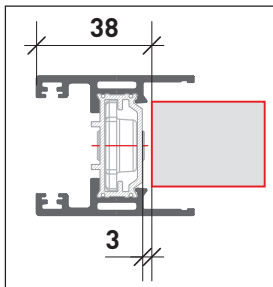









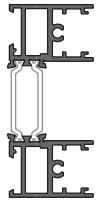





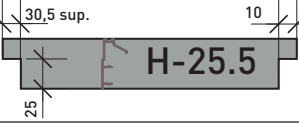

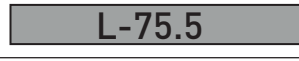
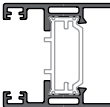
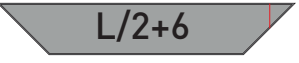
SCORREVOLE A 2 ANTE

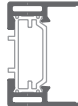
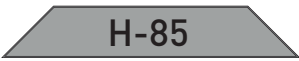
Soglia Ribassata

SLIDING Sash WITH 2 DOORS
Lowered threshold

Distinta di Taglio | *Cutting List*

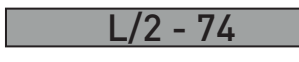
Profilo Profile	Taglio CUT	Qt.
 SX85.101	 L	1
	 H	2
 SX11.176	 L-74	1
 SX85.502	 H-25.5	2
 ASX.15.02	 L-75.5	2
 SX12.203	 L/2+6	4
	 H-49	2
 SX12.204	 H-85	2
 SX12.301	 H-67	2
 SX85.501	 L-75.5	4
 BX 53	 L/2 - 74	2

Guarnizioni

ASX 10.74	Guarn. vetro inserire mm.32 Gasket for glass mm. 32	4H+2L
ASX 10.72	Guarnizione profilo centrale Central profile gasket	2H
ASX 10.34 o ASX 10.69	Guarnizione tenuta anta Sealing gasket Sash	6H+6L
ASX 10.26	Barretta coprirotaia Rail cover bar	2H

Distinta Accessori | *Accessories List*

N° 1 ASX 85.K2AM
Kit Mobile + Mobile
2 Sliding Sashes kit

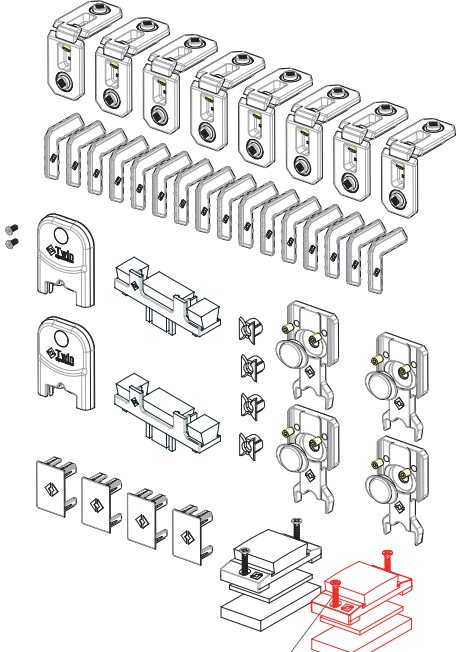

N° 2 ASX 85.CAR
Coppia carrello bilanciato regist.240 Kg anta
Balanced Adjustable roller 240 Kg Sash

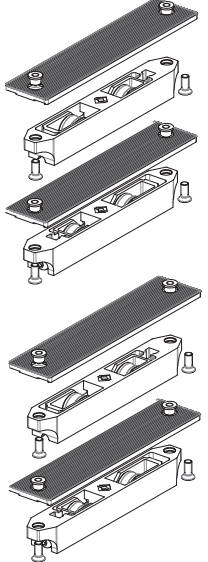

Non usare e sostituire con art. ASX 15.15 per soglia ribassata
Do not use and replace with art. ASX 15.15 for low threshold profile

ACX 50.SQ
N° 4
Squadretta telaio
Corner joint frame

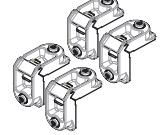

ASX 12.FAST60
N° 2 Kit
Fastlock 600 mm.

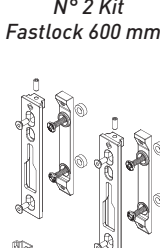

*** ARX 06.01**
Registro telaio
Frame adjuster



* Quantità secondo dimensioni
Quantity according to dimensions

ACX.08.71 SX

N° 1
Martellina SX disassata
Offset handle

**

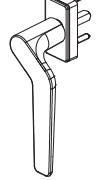

ASX08.77
Versione Telaio Scomparsa
Hidden Frame Version

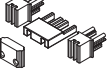

Anta fissa-Fixed Sash
ASX12.ANGFIS



Solo Fisso c/ Mobile
Only fixed Sash w/Mobile Sash

ASX.08.74

N° 1
Maniglia ad incasso
Embedded handle

**



Varianti

ASX 12.FAST100
N° 2 Kit
Fastlock 1000 mm.

ASX 12.FAST180
N° 2 Kit
Fastlock 1800 mm.

** Secondo preferenza - As per Choice

SCORREVOLE A 3 ANTE
2 Binari

SLIDING WITH 3 DOORS
3 Rails

Anta / Sash
SX12.203

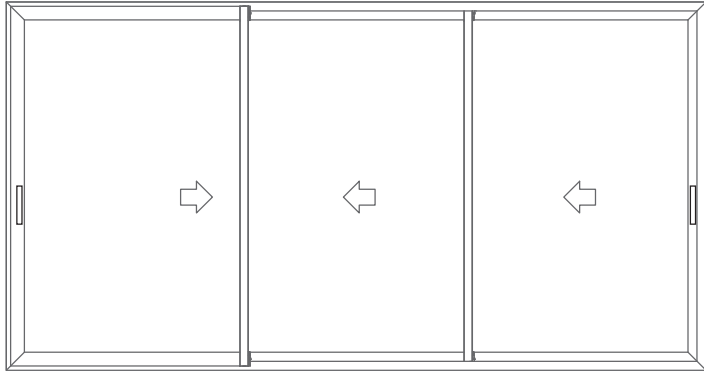

Distinta di taglio vetri
Glass cutting list



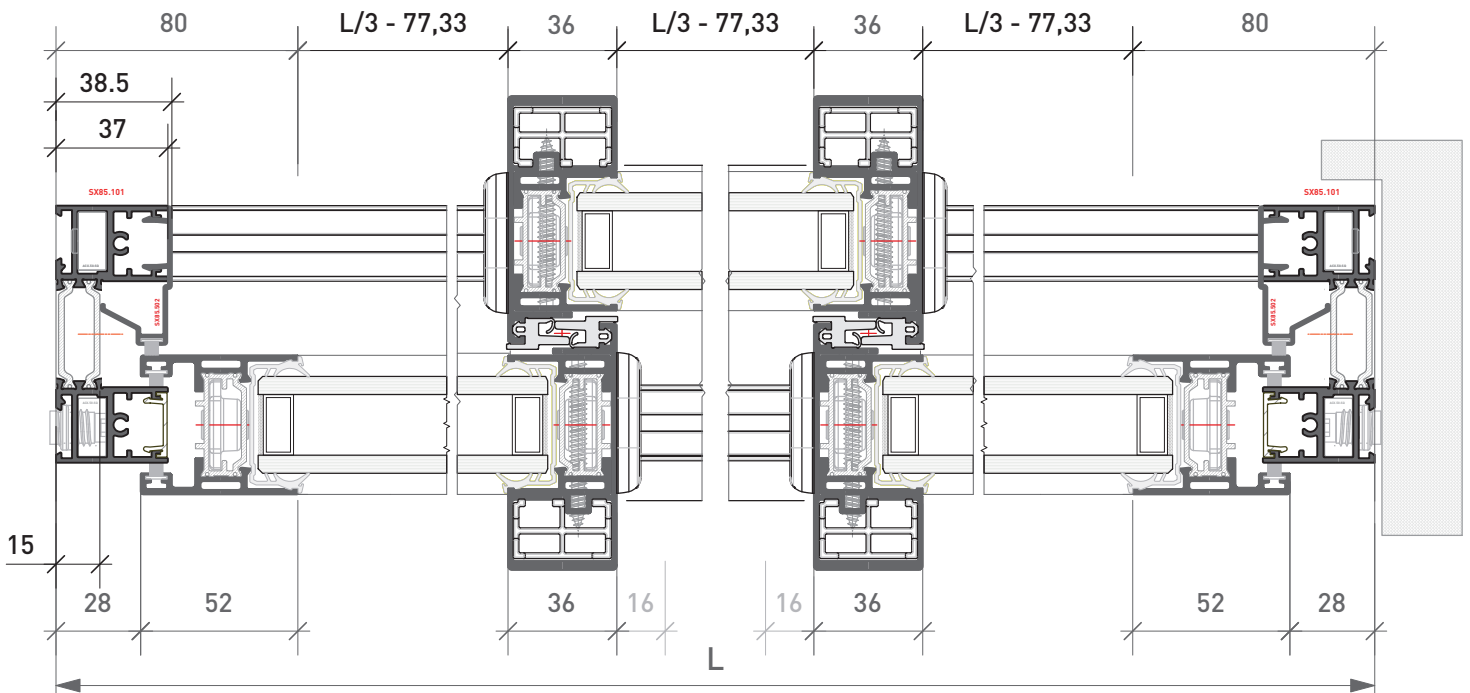
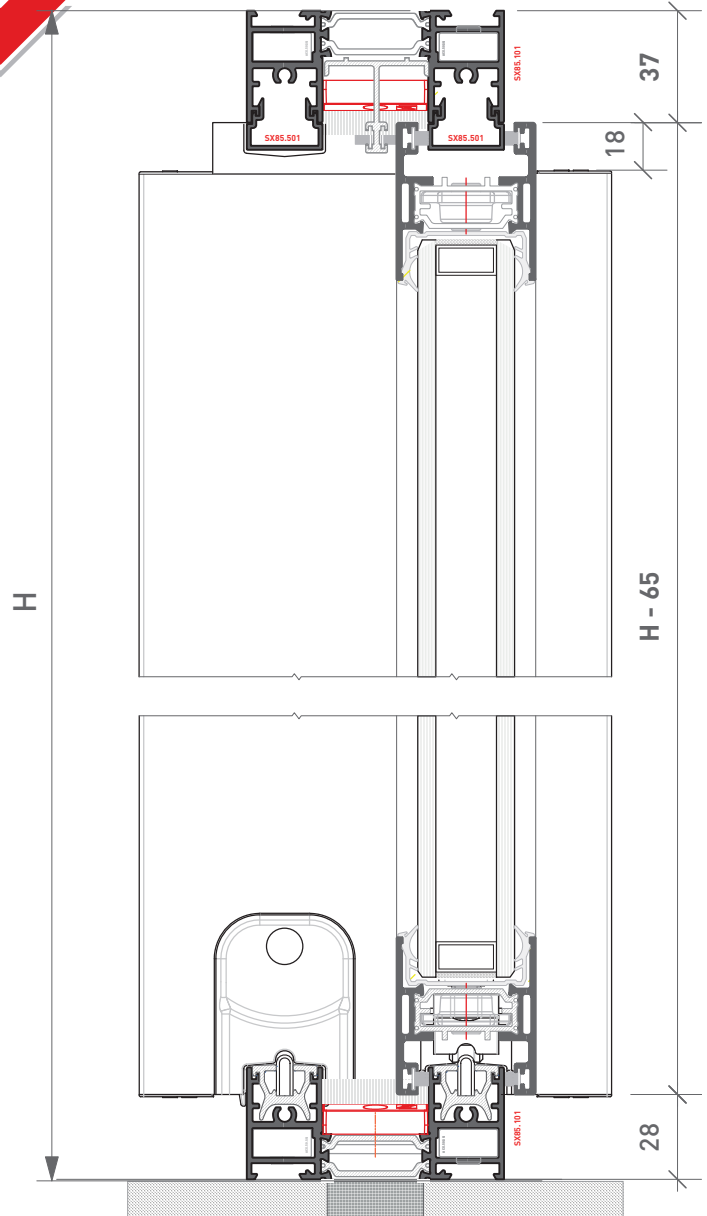
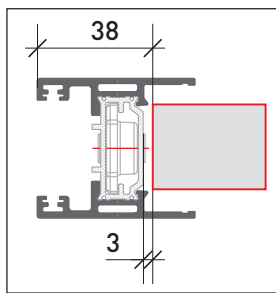





Q.tà	H	L
3	H - 141	L/3 - 49.33

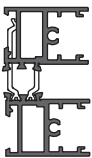

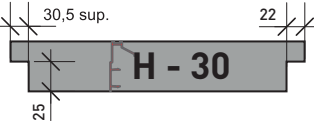
SCORREVOLE A 3 ANTE
2 Binari

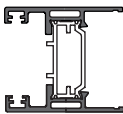
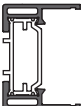
SLIDING WITH 3 DOORS
2 Rails

Distinta di Taglio | Cutting List

Profilo Profile	Taglio CUT	Qt.
	L	2
	H	2
SX85.101		
		2
SX85.502		
	L - 77	1
	L - 74	1
ASX.15.02		
	L - 77	1
	L - 74	1
BX09		
	L/3 + 26.7	6
	H - 65	2
SX12.203		
	H - 101	4
SX12.204		
	H - 83	4
SX12.301		
	L/3 + 5	1
	L2/3 - 79	1
	L/3 - 74	1
SX85.501		
	L/3 - 54	2
	L/3 - 113	1
BX 53		

Guarnizioni

ASX 10.74	Guarn. Vetro Inserire mm. 32 Gasket to Insert 32 mm.	6H+2L
ASX 10.72	Guarn. Profilo Centrale Central Profile Gasket	4H
ASX 10.34 o ASX 10.69	Guarn. di Tenuta Anta Sash Sealing Gasket	6H+6L
ASX 10.26	Barretta Copri Rotaia Rail Cover Bar	2H

Distinta Accessori | Accessories List

N° 1 ASX 85.K2AM
Kit Mobile + Mobile
2 Sliding Sashes kit

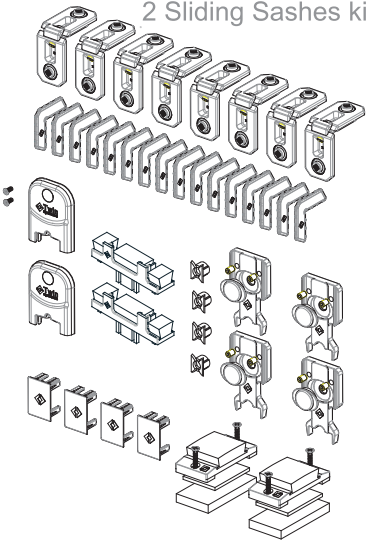

N° 3 ASX 85.CAR
Coppia carrello
bilanciato regist.240 Kg
anta Balanced
adjustable roller 240
Kg Sash

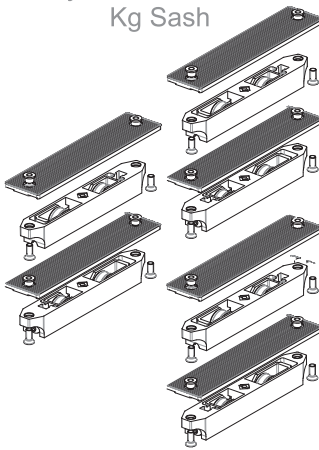

N° 1 ASX.85.K3AM
Kit aggiuntivo 3^a anta su 2 binari
Additional Kit Three tracks 2nd sash

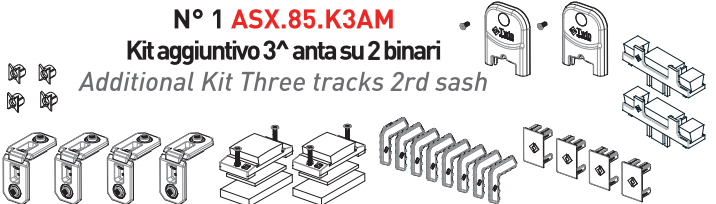

ACX 50.SQ
N° 8
Squadretta telaio
Corner joint frame

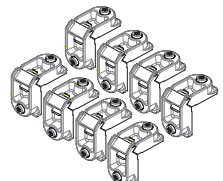

ASX 12.FAST60
N° 2 Kit
Fastlock 600 mm.

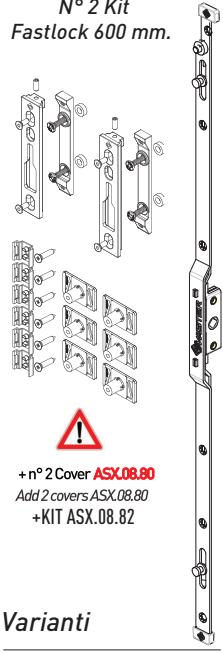

*** ARX 06.01**
Registro telaio
Frame adjuster



ACX.08.71 SX

N° 2
Martellina SX disassata
Offset handle

**

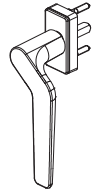

ASX.08.74

N° 2
Maniglia ad incasso
Embedded handle

**

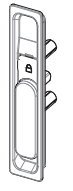

Varianti

ASX 12.FAST100
N° 2 Kit
Fastlock 1000 mm.

ASX 12.FAST180
N° 2 Kit
Fastlock 1800 mm.

*** ASX 12.VASCH**
Vaschetta drenaggio
Drainage system

* Quantità secondo dimensioni
Quantity according to dimensions



Anta fissa-Fixed Sash
ASX12.ANGFIS

Solo Fisso c/ Mobile
Only fixed Sash w/Mobile Sash

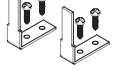

** Secondo preferenza - As per Choice



SCORREVOLE A 3 ANTE
3 Binari

SLIDING WITH 3 DOORS
3 Rails

Anta / Sash
SX12.203

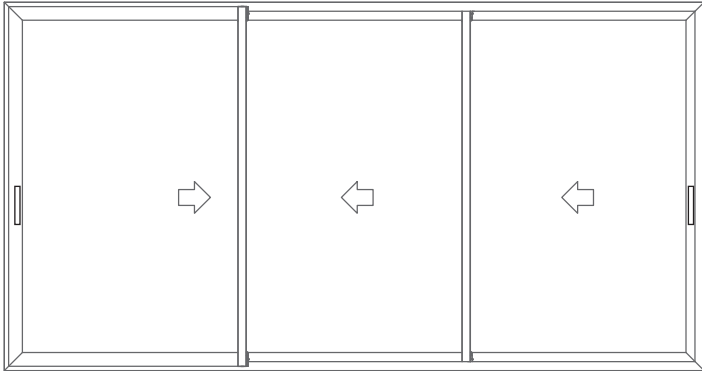

Distinta di taglio vetri
Glass cutting list

Q.tà	H	L
3	H - 141	L/3 - 49.33

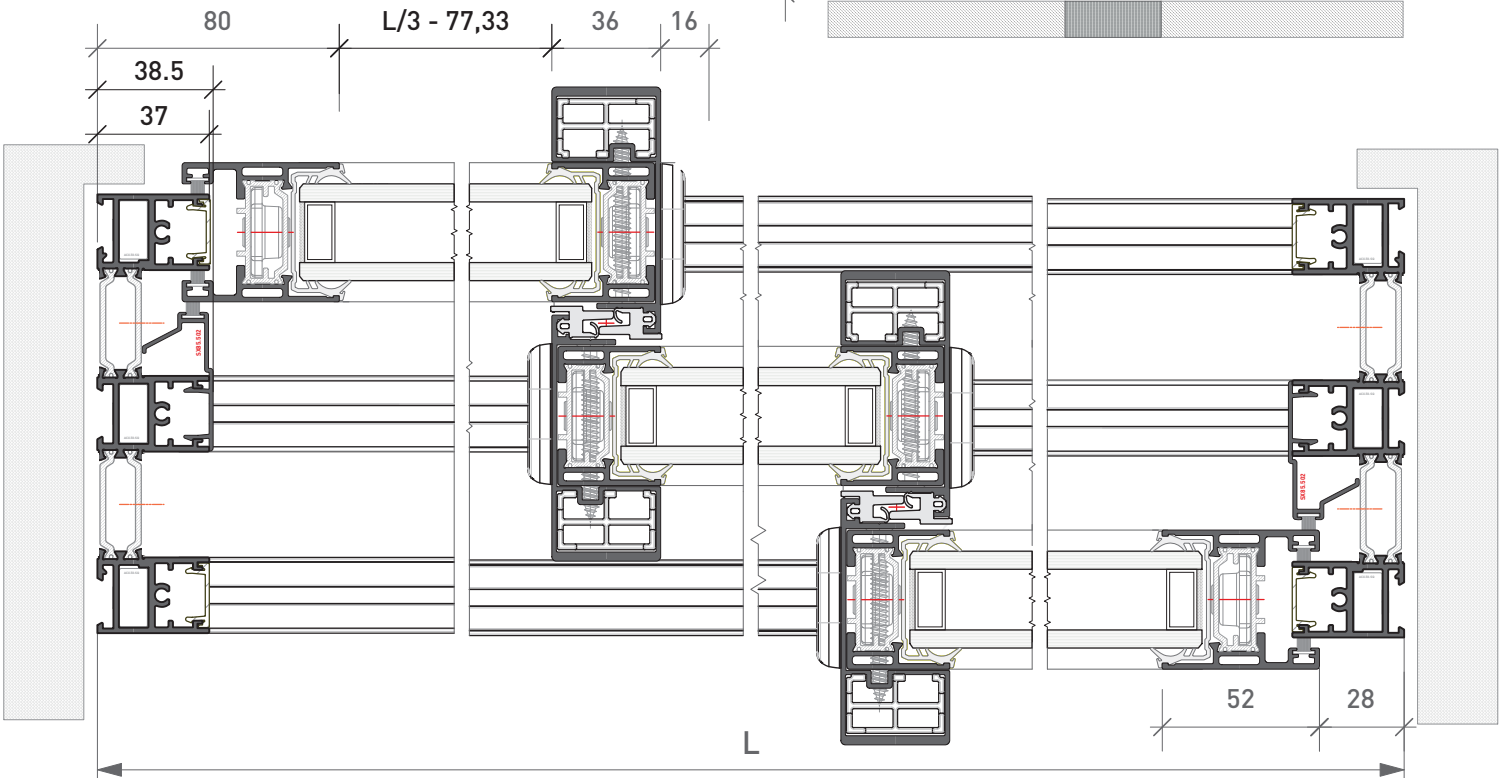
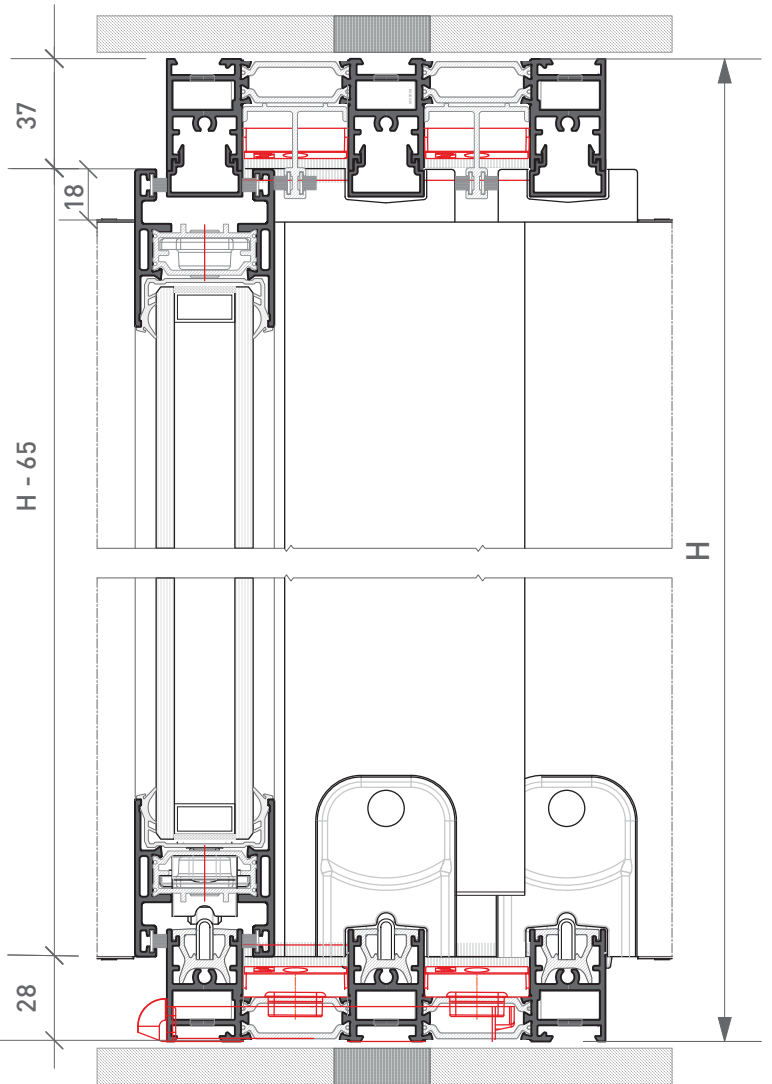
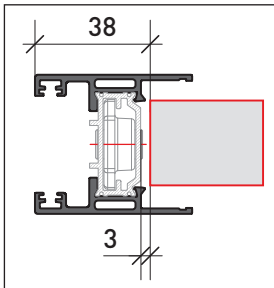











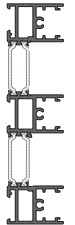



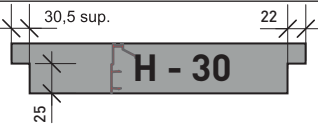

SCORREVOLE A 3 ANTE

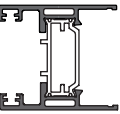
3 Binari

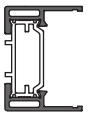
SLIDING WITH 3 DOORS
3 Rails

Distinta di Taglio | Cutting List

Distinta Accessori | Accessories List

Profilo Profile	Taglio CUT	Qt.
 SX85.102	 L	2
 H	2	
 SX85.502	 H - 30	2
 ASX.15.02	L - 77	1
 ASX.15.02	L - 74	2
 BX09	L - 77	1
 BX09	L - 74	2
 SX12.203	L/3 + 26.7	6
 SX12.203	H - 65	2
 SX12.204	H - 101	4
 SX12.301	H - 83	2
 SX12.301	H - 83	2
 SX85.501	L/3 + 5	3
 SX85.501	L2/3 - 79	3
 BX 53	L/3 - 54	2
 BX 53	L2/3 - 72	2

N° 1 ASX 85.K2AM
Kit Mobile + Mobile
2 Sliding Sashes kit

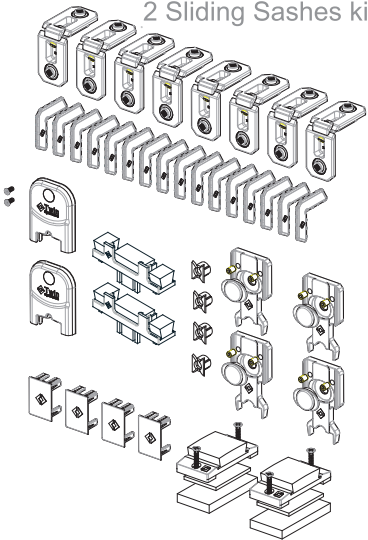



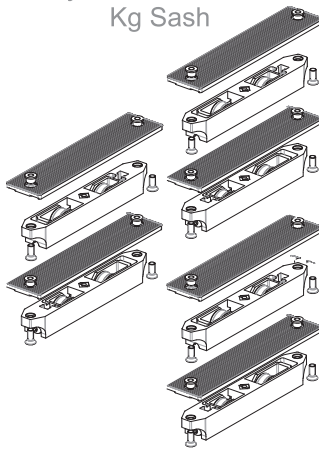

N° 3 ASX 85.CAR
Coppia carrello
bilanciato regist.240 Kg
anta Balanced
adjustable roller 240
Kg Sash

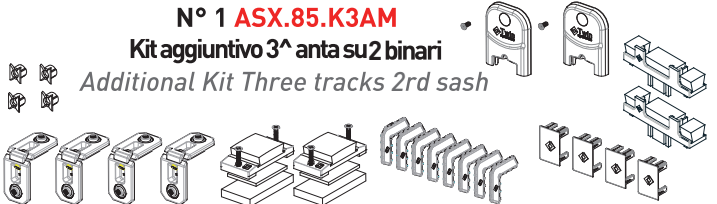

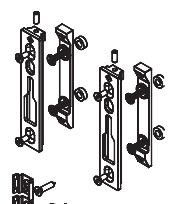
N° 1 ASX.85.K3AM
Kit aggiuntivo 3^a anta su 2 binari
Additional Kit Three tracks 2nd sash

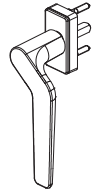

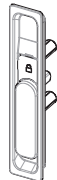
<p>ACX 50.SQ N° 12 Squadretta telaio Corner joint frame</p> 	<p>ASX 12.FAST60 N° 2 Kit Fastlock 600 mm.</p> 	<p>* ARX 06.01 Registro telaio Frame adjuster</p> 
<p>ACX.08.71 SX</p> <p>N° 1 Martellina SX disassata Offset handle</p> 	<p>* ASX 12.VASCH Vaschetta drenaggio Drainage system</p> 	<p>* ASX 12.ANGFIS</p> <p>Anta fissa-Fixed Sash ASX12.ANGFIS</p> 
<p>ASX.08.74</p> <p>N° 1 Maniglia ad incasso Embedded handle</p> 	<p>Varianti</p> <p>ASX 12.FAST100 N° 2 Kit Fastlock 1000 mm.</p> <p>ASX 12.FAST180 N° 2 Kit Fastlock 1800 mm.</p>	<p>Solo Fisso c/ Mobile Only fixed Sash w/Mobile Sash</p>

** Secondo preferenza - As per Choice

SCORREVOLE A 4 ANTE

SLIDING Sash WITH 4 DOORS

Anta / Sash
SX12.203

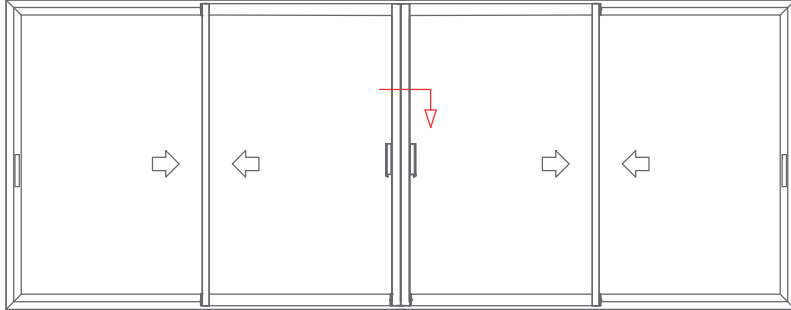

Distinta di taglio vetri
Glass cutting list



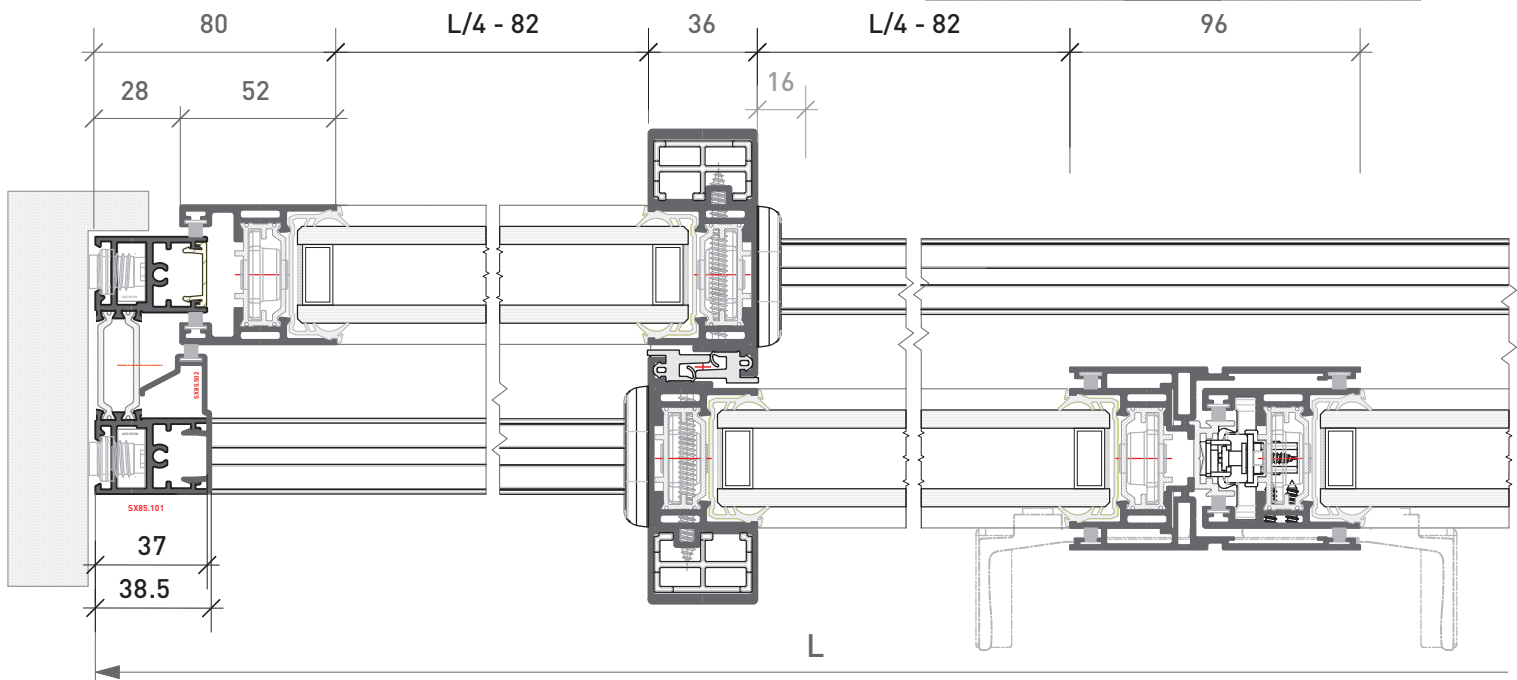
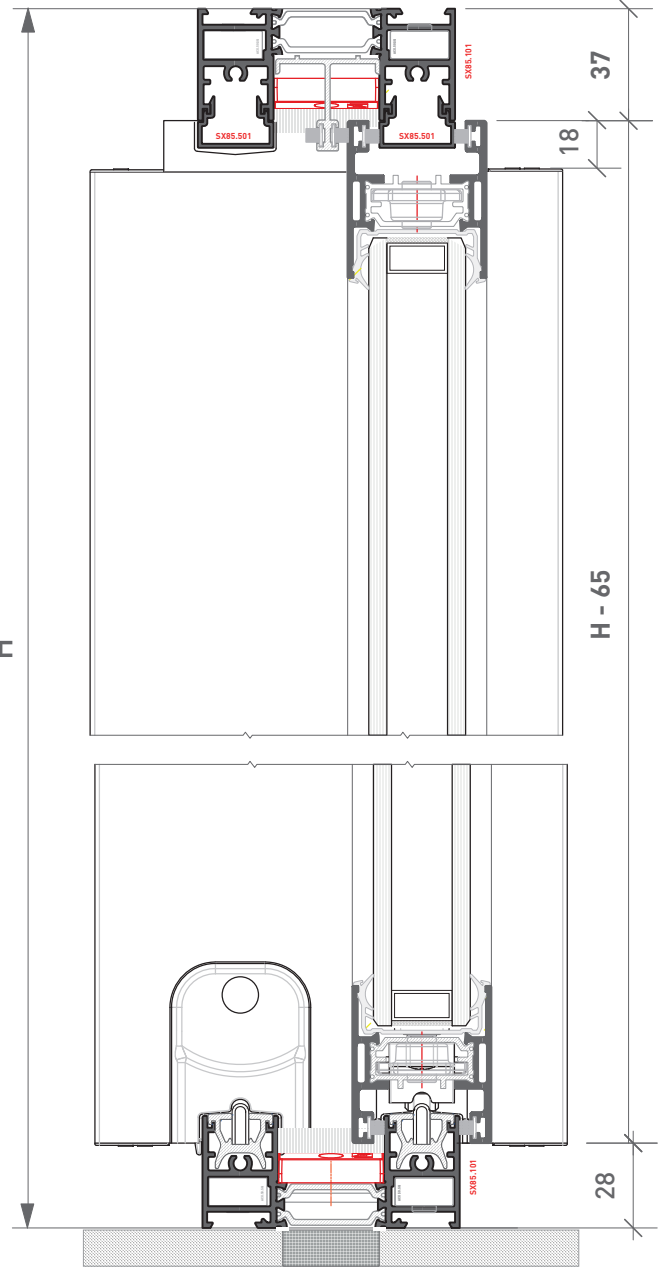
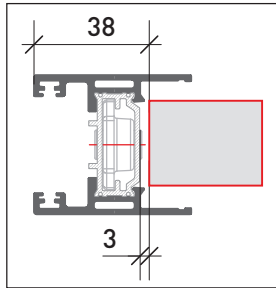





Q.tà	H	L
4	H - 141	L/4 - 54

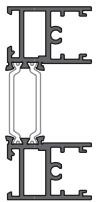

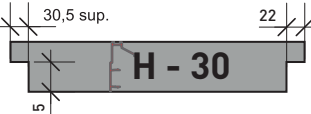
SCORREVOLE A 4 ANTE

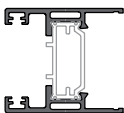
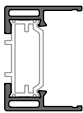
SLIDING Sash WITH 4 DOORS

Distinta di Taglio | *Cutting List*

Profilo <i>Profile</i>	Taglio <i>CUT</i>	Qt.
	L H	2 2
SX85.101		
		2
SX85.502		
	L - 77 L - 74	1 1
ASX15.02		
	L - 77 L - 74	1 1
BX09		
	L/4 + 22 H - 65	8 3
SX12.203		
	H - 101	5
SX12.204		
	H - 83	4
SX12.301		
	L/3 - 235 L/3 + 396	4 2
SX85.501		
	H - 65	2
SX12.303		
	L/4 - 58 L/2 - 103	2 1
BX 53		

Guarnizioni

ASX 10.74	Guarn. Inserire Vetro mm. 32 <i>Gasket to Insert 32 mm.</i>	8H+2L
ASX 10.72	Guarn. Profilo Centrale <i>Central Profile Gasket</i>	4H
ASX 10.34 o ASX 10.69	Guarn. di Tenuta Anta <i>Sash Sealing Gasket</i>	12H+6L
ASX 10.26	Barretta Copri Rotaia <i>Rail Cover Bar</i>	2H

Distinta Accessori | *Accessories List*

N° 2 ASX 85.K2AM
Kit Mobile + Mobile

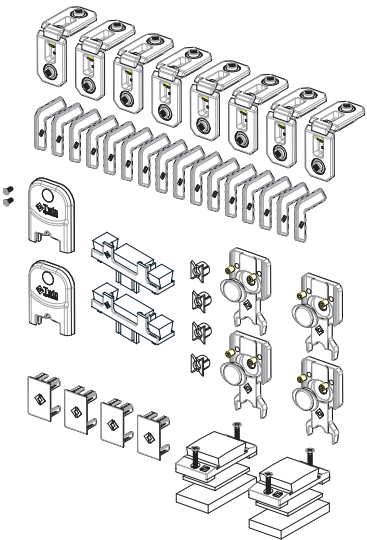

N° 4 ASX 85.CAR
Coppia carrello bilanciato regist.240 Kg anta
Balanced adjustable roller 240 Kg Sash

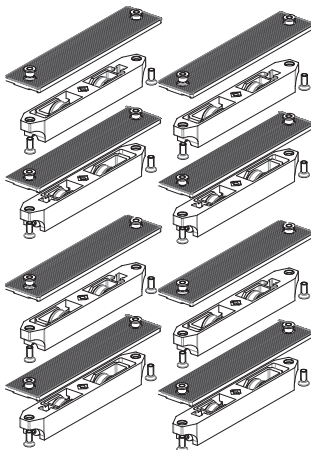

N° 1 ASX.85.K4AM
Kit tappi 4^ anta
4th sash Cap Kit

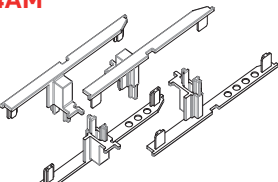

ACX 50.SQ
N° 8
Squadretta telaio
Corner joint frame

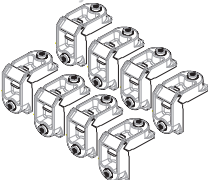

ASX 12.FAST60
N° 3 Kit Fastlock
600 mm.

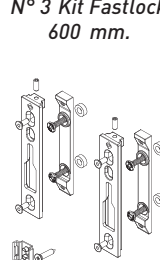

*** ARX 06.01**
Registro telaio
Frame adjuster



* Quantità secondo dimensioni
Quantity according to dimensions

ASX 12.MTMSX o DX
1 Pz. KIT Maniglia SX or DX
1 Pz. LX or DX Handle KIT

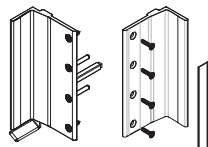

ASX 12.MTF
1 Pz. Maniglia traino fissa
1 Pz. FIXED train handle

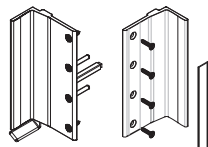

*** ASX 12.VASCH**
Vaschetta drenaggio
Drainage system



* Quantità secondo dimensioni
Quantity according to dimensions

ASX 08.74



N° 2
Maniglia ad incasso
Embedded handle

Varianti

ASX 12.FAST100
N° 3 Kit
Fastlock 1000 mm.

ASX 12.FAST180
N° 3 Kit
Fastlock 1800 mm.

Anta fissa-Fixed Sash
ASX12.ANGFIS



Solo Fisso c/ Mobile
Only fixed Sash w/Mobile Sash

ASX 12.BTMDX
2 Pz. Base Maniglia Lat.
2 Pz. Side Handle Base plate.



** Secondo preferenza - *As per Choice*

SCORREVOLE A 4 ANTE CON ANGOLO

SLIDING Sash WITH 4 DOORS WITH CORNER

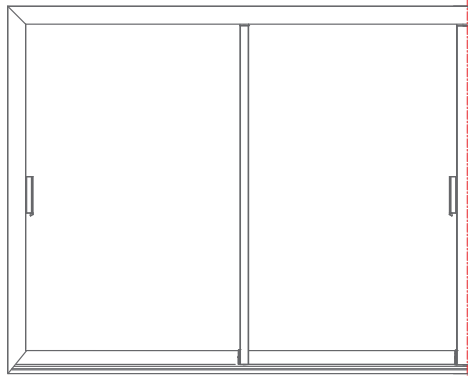

Anta / Sash
SX12.203

Distinta di taglio vetri
Glass cutting list



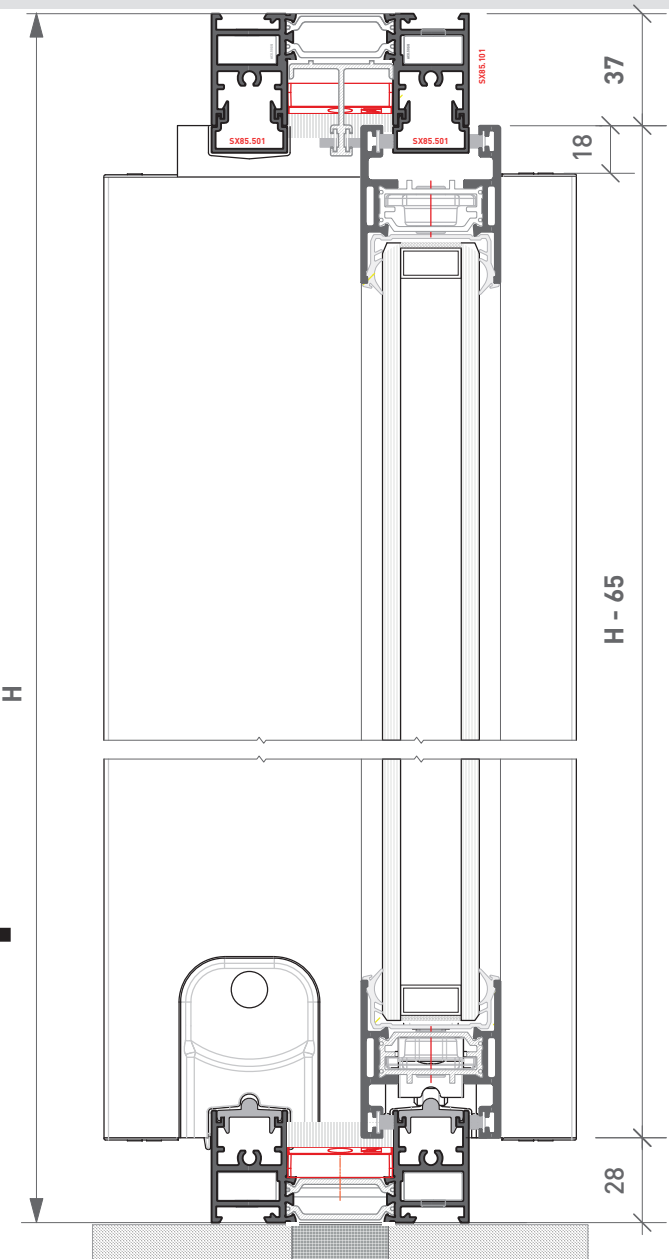
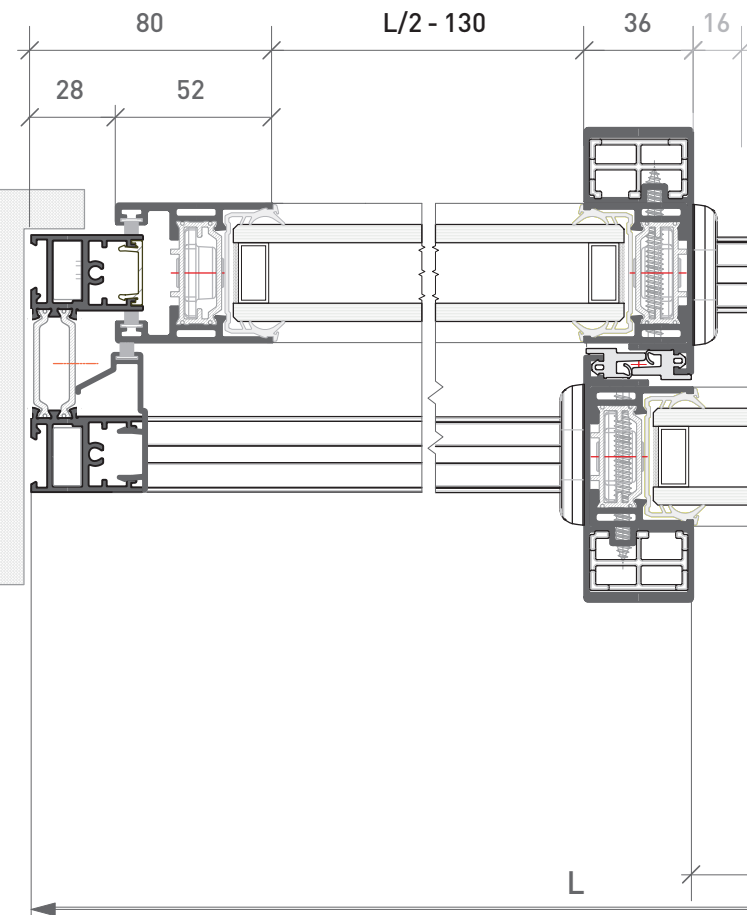
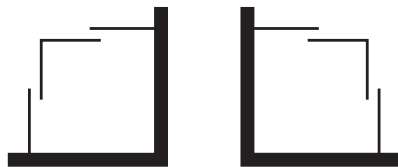
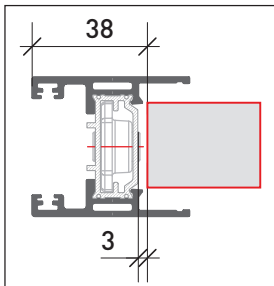







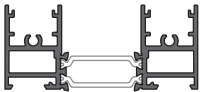





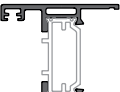

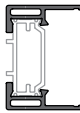





Q.tà	H	L
4	H - 141	L/2 - 102

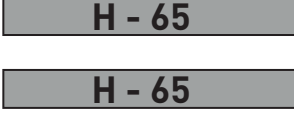

SCORREVOLE A 4 ANTE CON ANGOLO

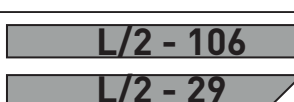
SLIDING Sash WITH 4 DOORS WITH CORNER

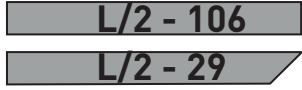
Distinta di Taglio | *Cutting List*

Profilo <i>Profile</i>	Taglio <i>CUT</i>	Qt.
 SX85.101		2 2 2
 SX85.502		2
 SX85.505		2 2
 SX12.203		8 2
 SX12.204		4
 SX12.301		4
 SX85.501		2 2
 SX12.205		2
 SX12.306		1
 SX12.304		2
 SX12.305		1
 BX 53		2 2
 BX 30		2

Guarnizioni

ASX 10.74	Guarn.Ins. Vetro 32mm. <i>Gasket to Insert 32 mm.</i>	8H+4L
ASX 10.72	Guarn. Profilo Centrale <i>Central Profile Gasket</i>	4H
ASX 10.34 ASX 10.69	Guarn. di Tenuta Anta <i>Sash Sealing Gasket</i>	14H+12L
ASX 10.26	Barretta Copri Rotaia <i>Rail Cover Bar</i>	2H

Distinta Accessori | *Accessories List*

N° 2 ASX 85.K2AM
Kit Mobile + Mobile

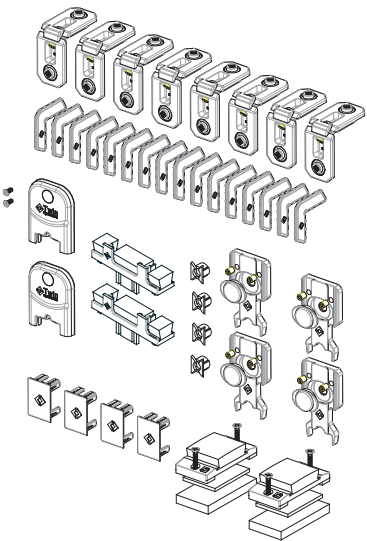

N° 4 ASX 85.CAR
Coppia carrello bilanciato regist.240 Kg anta
Balanced adjustable roller 240 Kg Sash

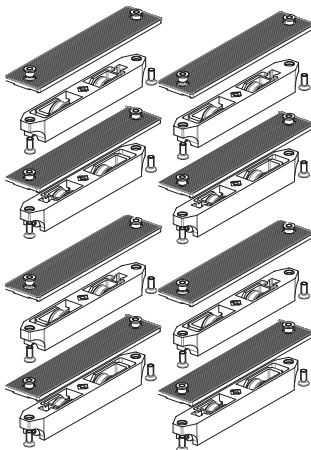

ASX.85.KANG
Kit soluzione angolare DX-SX
RIGHT-LEFT corner solution kit

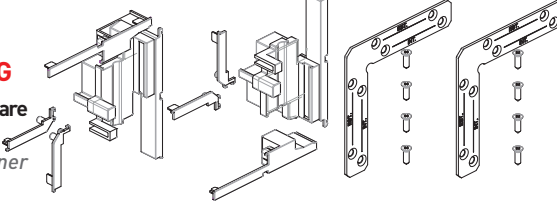

ACX 50.SQ
N° 8
Squadretta telaio
Corner joint frame

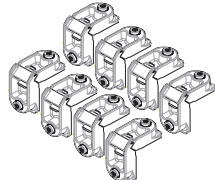

ASX 12.FAST60
N° 3 Kit Fastlock
600 mm.

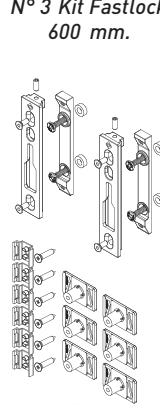

*** ARX 06.01**
Registro telaio
Frame adjuster



* Quantità secondo dimensioni
Quantity according to dimensions

ASX 12.MTMDX
1 Pz. KIT Maniglia DX
1 Pz. DX Handle KIT

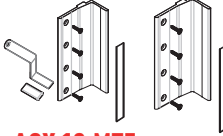

ASX 12.MTF
1 Pz. Maniglia traino fissa
1 Pz. FIXED train handle

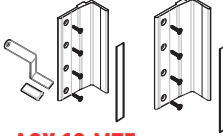

*** ASX 12.VASCH**
Vaschetta drenaggio
Drainage system



* Quantità secondo dimensioni
Quantity according to dimensions

ASX.08.74



N° 2
Maniglia ad incasso
Embedded handle

Varianti

ASX 12.FAST100
N° 3 Kit
Fastlock 1000 mm.

ASX 12.FAST180
N° 3 Kit
Fastlock 1800 mm.

Anta fissa-Fixed Sash
ASX12.ANGFIS

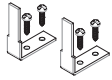

Solo Fisso c/ Mobile
Only fixed Sash w/Mobile Sash

ASX 12.BTMDX
2 Pz. Base Maniglia Lat.
2 Pz. Side Handle Base plate.



** Secondo preferenza - *As per Choice*



SCORREVOLE A 2 ANTE

SLIDING DOOR WITH 2 DOORS

Anta / Sash
SX85.201

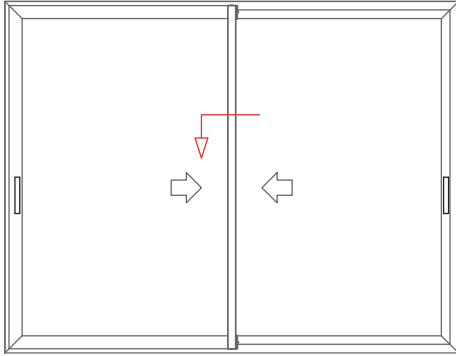

Distinta di taglio vetri
Glass cutting list

Q.tà	H	L
2	H - 177	L/2 - 88

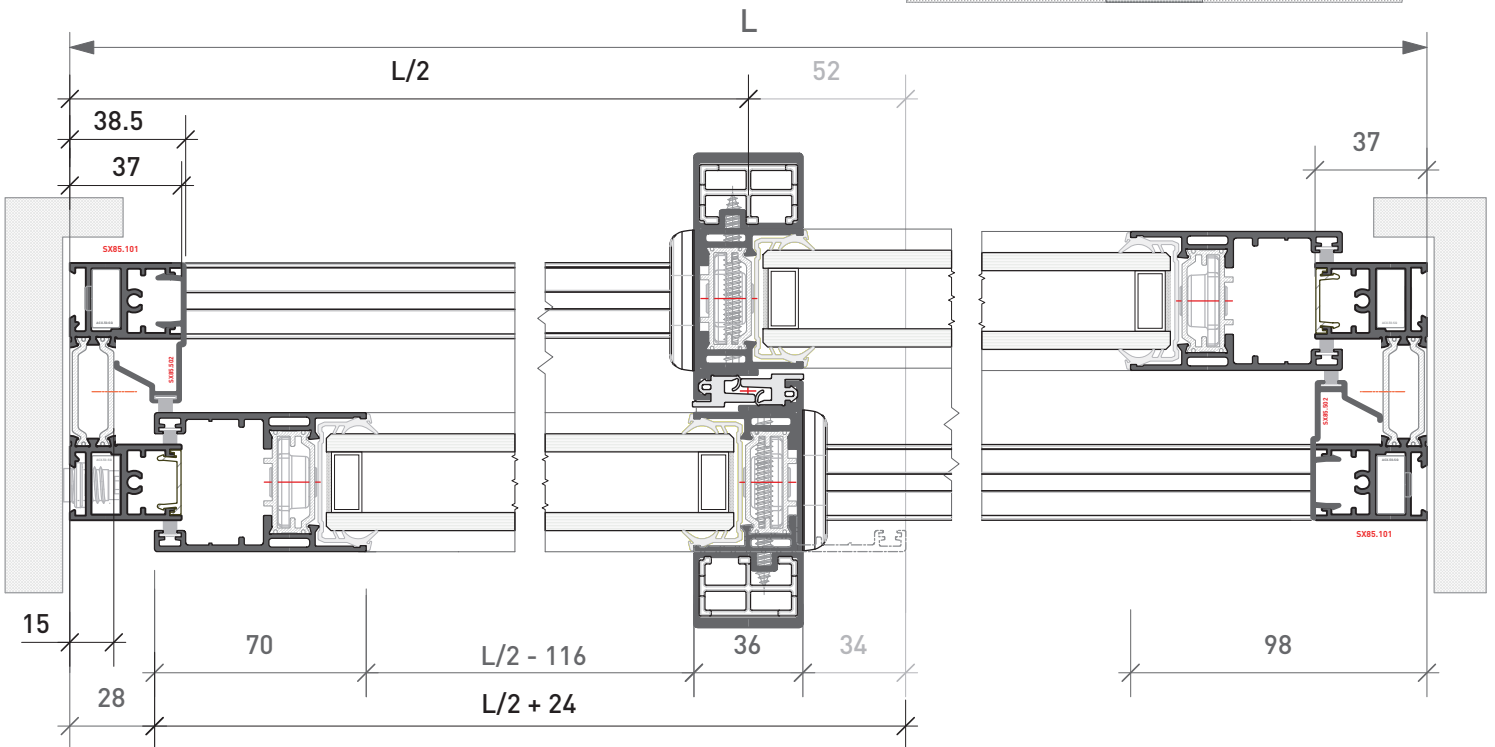
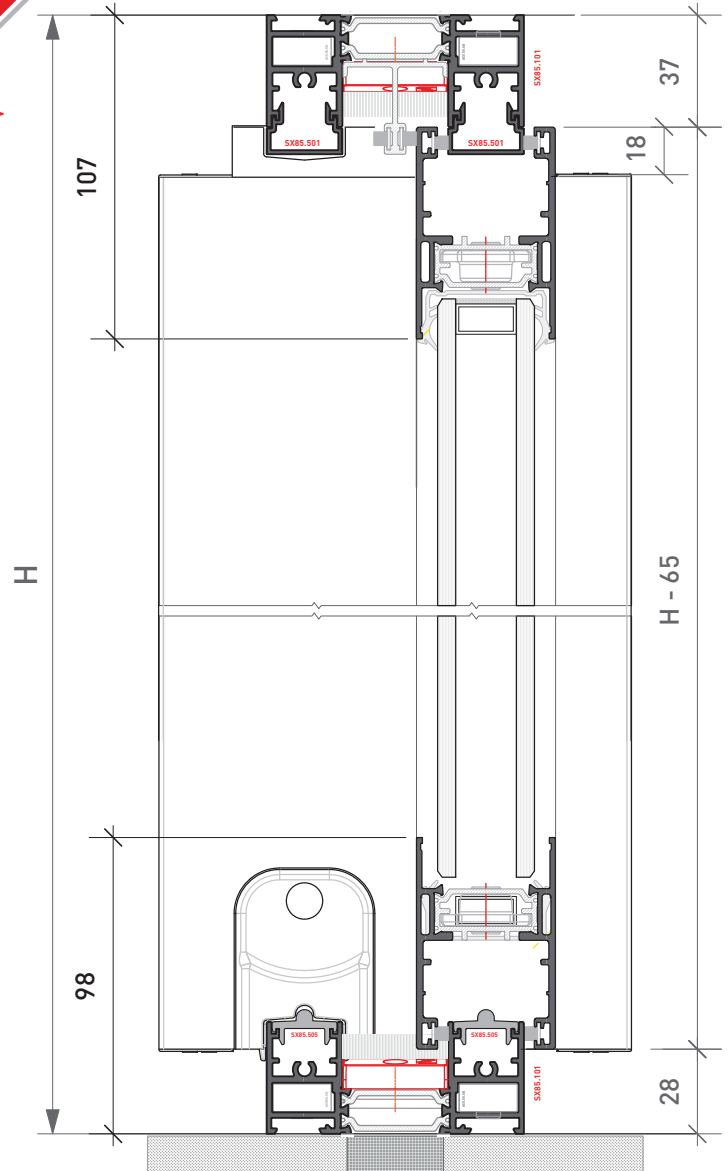
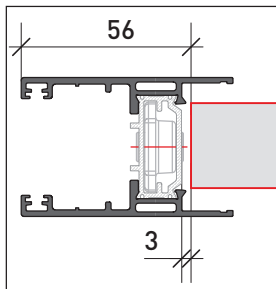









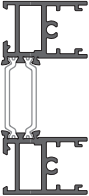



SCORREVOLE A 2 ANTE

SLIDING DOOR WITH 2 DOORS

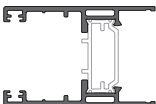
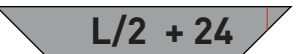
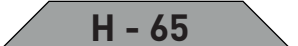
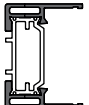
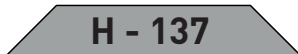
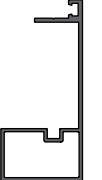

Distinta di Taglio | Cutting List

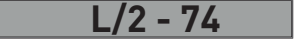
Profilo Profile	Taglio CUT	Qt.
 SX85.101	 L	2
 SX85.101	 H	2
 SX85.502	 H - 30	2
 SX85.505	 L - 75.5	2
 SX85.201	 L/2 + 24	4
	 H - 65	2
 SX12.204	 H - 137	2
 SX12.301	 H - 83	2
	 SX85.501	 L - 75.5
 BX 53	 L/2 - 74	2

Guarnizioni

ASX 10.74	Guarn. Inserire Vetro mm. 32 Gasket to Insert 32 mm.	4H+2L
ASX 10.72	Guarn. Profilo Centrale Central Profile Gasket	2H
ASX 10.34 o ASX 10.69	Guarn. di Tenuta Anta Sash Sealing Gasket	6H+6L
ASX 10.26	Barretta Copri Rotaia Rail Cover Bar	2H

Distinta Accessori | Accessories List

N°1 ASX.85.K2AMG
Kit Mobile+ Mobile Anta magg. - 240 Kg anta
2 Sliding Sashes kit - 240 Kg Sash

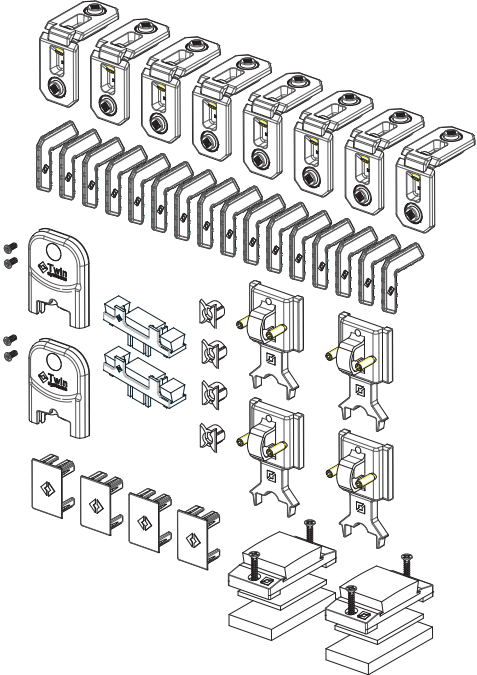

N° 2 ASX 85.CARMAG
Cp. carrello bilanciato regist. 240 Kg anta
Balanced adjustable roller 240 Kg Sash

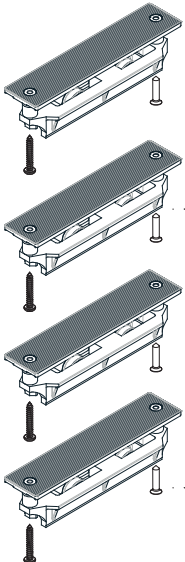

ACX 50.SQ
N° 8
Squadretta telaio
Corner joint frame

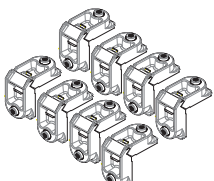

ASX 13.02**
N° 2 Kit
Fastlock su anta
H min. 750 mm.
Fastlock on Sash
H min. 750 mm



*** ARX 06.01**
Registro telaio
Frame adjuster



* Quantità secondo dimensioni
Quantity according to dimensions

ACX.08.71sx

N° 1
Martellina SX disassata
Offset handle

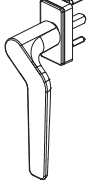

ASX.85.02**
N° 2 Kit

Kit Ricontri
Fastlock kit

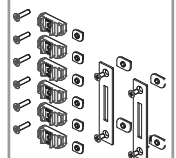

*** ASX 12.VASCH**
Vaschetta drenaggio
Drainage system



* Quantità secondo dimensioni
Quantity according to dimensions

ASX.08.74

N° 1
Maniglia ad incasso
Embedded handle



Anta fissa-Fixed Sash
ASX12.ANGFIS

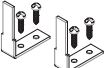

Solo Fisso c/ Mobile
Only fixed Sash w/Mobile Sash

**** Secondo preferenza - As per Choice**



SCORREVOLE A 2 ANTE
Soglia Ribassata

SLIDING DOOR WITH 2 DOORS
Lowered threshold

Anta / Sash
SX85.201

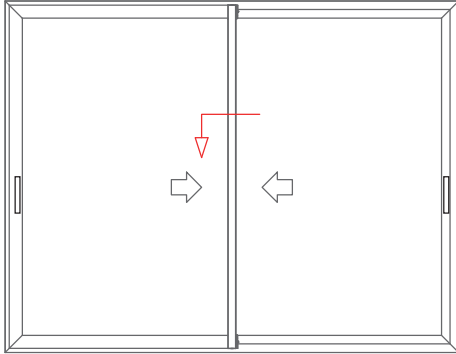

Distinta di taglio vetri
Glass cutting list

Q.tà	H	L
2	H - 161	L/2 - 88

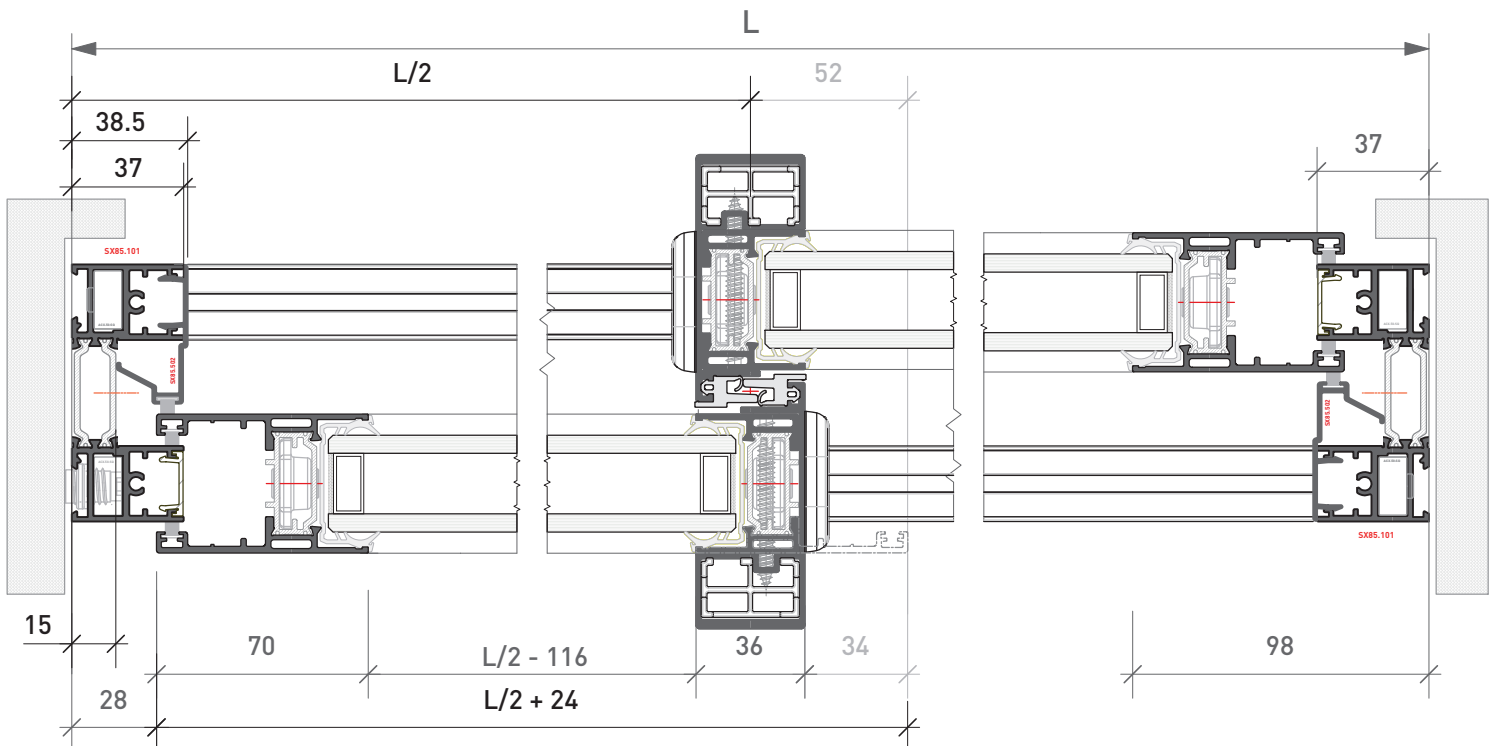
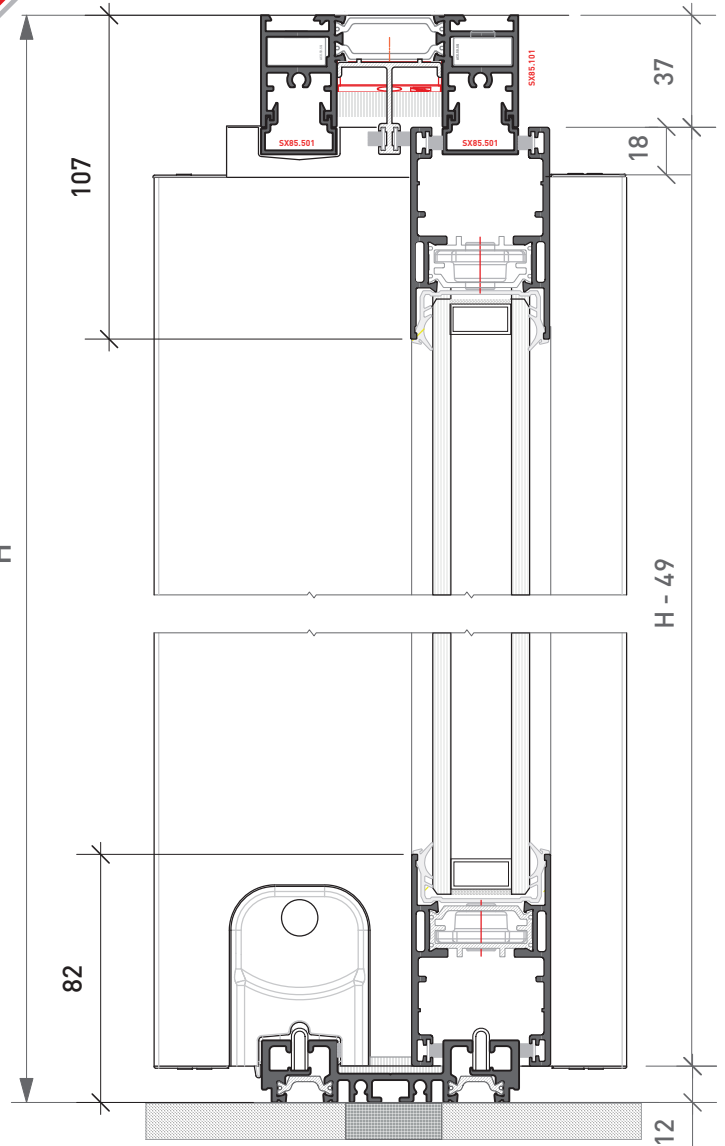
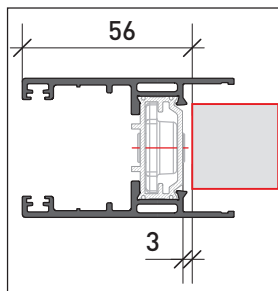









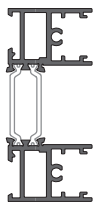





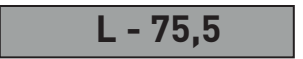
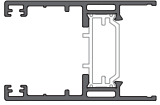
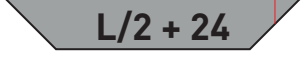

SCORREVOLE A 2 ANTE

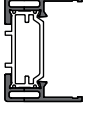
Soglia Ribassata

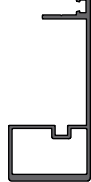
SLIDING DOOR WITH 2 DOORS
Lowered threshold

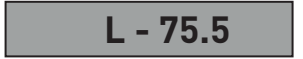
Distinta di Taglio | *Cutting List*

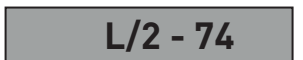
Profilo Profile	Taglio CUT	Qt.
 SX85.101	 L	1
	 H	2
 SX11.176	 L - 74	1
 SX85.502	 H - 25	2
 ASX 15.02	 L - 75,5	2
 SX85.201	 L/2 + 24	4
	 H - 49	2
 SX12.204	 H - 121	2
 SX12.301	 H - 67	2
 SX85.501	 L - 75.5	2
 BX 53	 L/2 - 74	2

Guarnizioni

ASX 10.74	Guarn. Inserire Vetro mm. 32 Gasket to Insert 32 mm.	4H+2L
ASX 10.72	Guarn. Profilo Centrale Central Profile Gasket	2H
ASX 10.34 o ASX 10.69	Guarn. di Tenuta Anta Sash Sealing Gasket	6H+6L
ASX 10.26	Barretta Copri Rotaia Rail Cover Bar	2L

Distinta Accessori | *Accessories List*



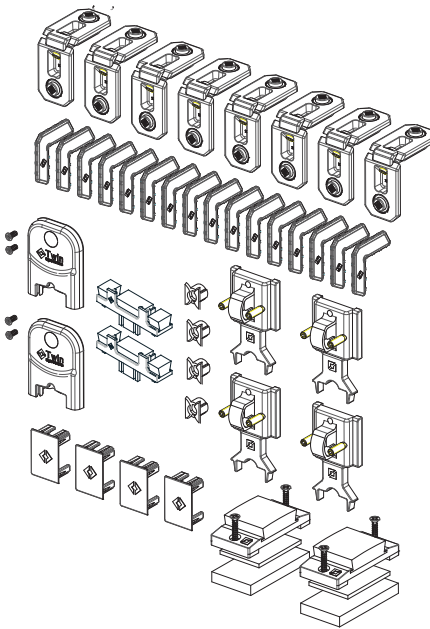

N°1 ASX.85.K2AMG
Kit Mobile+ Mobile Anta magg. - 240 Kg anta
2 Sliding Sashes kit - 240 Kg Sash

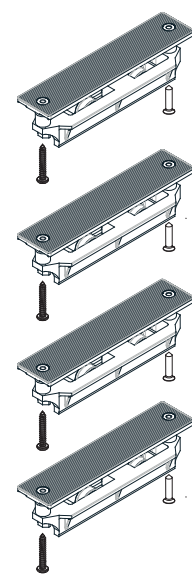

N° 2 ASX 85.CARMAG
Cp. carrello bilanciato regist. 240 Kg anta
Balanced adjustable roller 240 Kg Sash

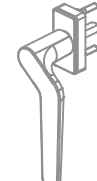
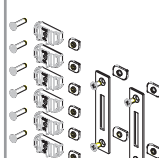
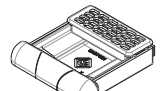

Non usare e sostituire con art. ASX 15.15 per soglia ribassata
Do not use and replace with art. ASX 15.15 for low threshold profile

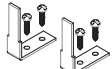
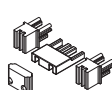
<p>ACX 50.SQ N° 4 Squadretta telaio Corner joint frame</p> 	<p>ASX 13.02** N° 2 Kit Fastlock su anta H min. 750 mm. Fastlock on Sash H min. 750 mm</p> 	<p>* ARX 06.01 Registro telaio Frame adjuster</p>  <p><small>* Quantità secondo dimensioni Quantity according to dimensions</small></p>
<p>ACX.08.71sx N° 1 Martellina SX disassata Offset handle</p> 	<p>ASX.85.02** N° 2 Kit Kit Ricontri Fastlock kit</p> 	<p>* ASX 12.VASCH Vaschetta drenaggio Drainage system</p>  <p><small>* Quantità secondo dimensioni Quantity according to dimensions</small></p>
<p>ASX.08.74 N° 1 Maniglia ad incasso Embedded handle</p> 	<p>ASX12.ANGFIS Anta fissa-Fixed Sash Only fixed Sash w/Mobile Sash</p> 	<p>ASX08.77 Versione Telaio Scomparsa Hidden Frame Version</p> 

** Secondo preferenza - As per Choice

SCORREVOLE A 3 ANTE
2 Binari

SLIDING WITH 3 DOORS
3 Rails
Anta / Sash
SX85.201

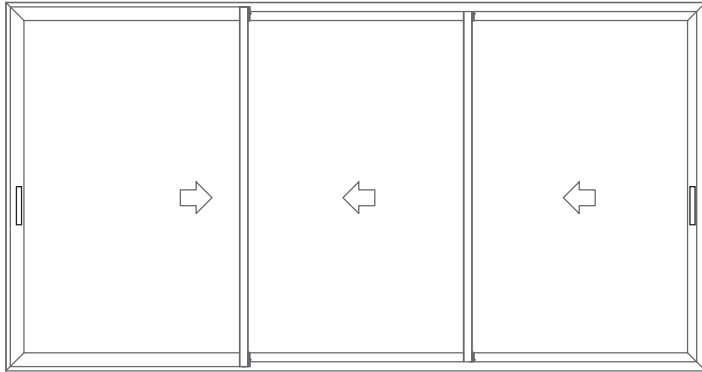

Distinta di taglio vetri
Glass cutting list



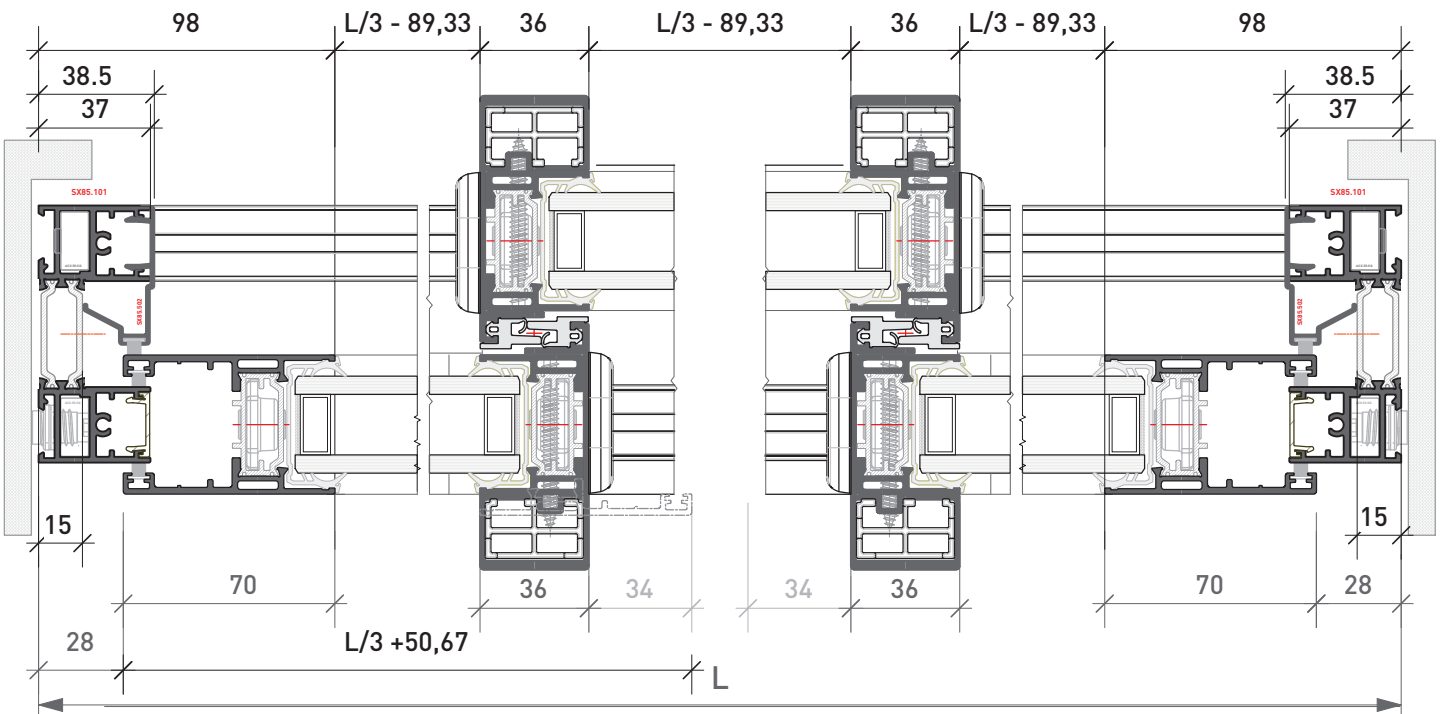
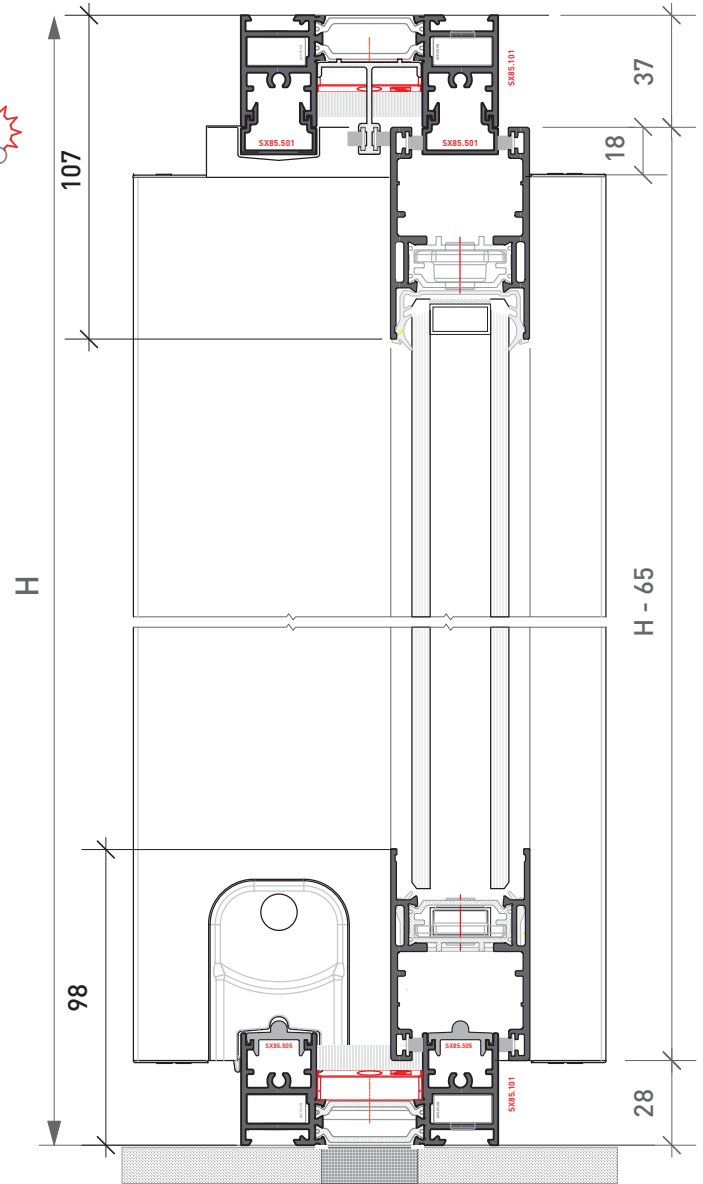
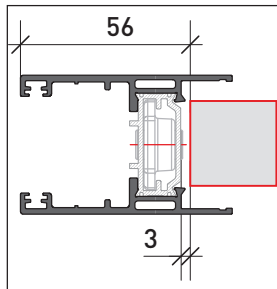



Q.tà	H	L
3	H - 177	L/3 - 61.5

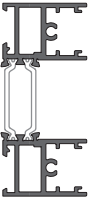
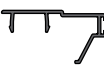
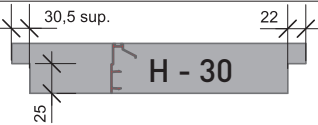

SCORREVOLE A 3 ANTE
2 Binari

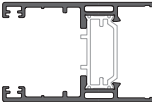
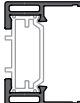
SLIDING WITH 3 DOORS
2 Rails

Distinta di Taglio | *Cutting List*

Profilo Profile	Taglio CUT	Qt.
	L H	2 2
SX85.101		
		2
SX85.502		
	L - 77 L - 74	1 1
SX85.505		
	L/3 + 50.7 H - 65	6 2
SX85.201		
	H - 137	4
SX12.204		
	H - 83	4
SX12.301		
	L / 3 + 5 L2/3 - 79 L - 74	1 1 1
SX85.501		
	L/3 - 47.5 L/3 - 124.5	2 1
BX 53		

Guarnizioni

ASX 10.74	Guarn. Inserire Vetro mm. 32 Gasket to Insert 32 mm.	6H+2L
ASX 10.72	Guarn. Profilo Centrale Central Profile Gasket	4H
ASX 10.34 o ASX 10.69	Guarn. di Tenuta Anta Sash Sealing Gasket	6H+6L
ASX 10.26	Barretta Copri Rotaia Rail Cover Bar	2H

Distinta Accessori | *Accessories List*

N°1 ASX.85.K2AMG
Kit Mobile+ Mobile Anta magg.
2 Sliding Sashes kit - 240 Kg Sash

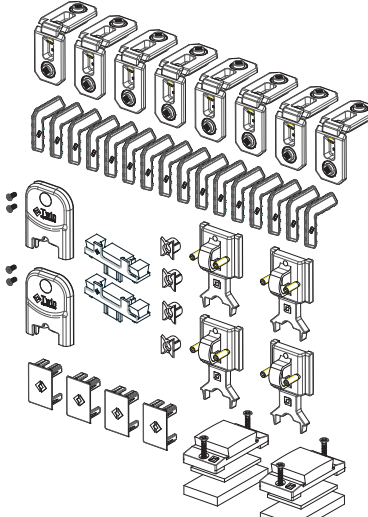

N° 3 ASX 85.CARMAG
Cp. carrello bilanciato regist. 240 Kg anta
Balanced adjustable roller 240 Kg Sash

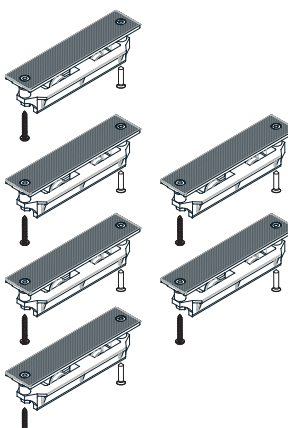

N° 1 ASX.85.K3AM
Kit aggiuntivo 3^ anta su 2 binari
Additional Kit Three tracks 3rd sash

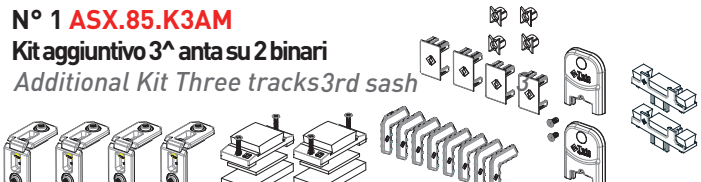

ACX 50.SQ
N° 8
Squadretta telaio
Corner joint frame

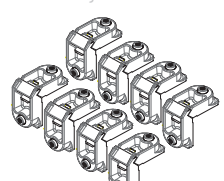

ASX 13.02**
N° 2 Kit
Fastlock su anta
H min. 750 mm.
Fastlock on Sash
H min. 750 mm



*** ARX 06.01**
Registro telaio
Frame adjuster



* Quantità secondo dimensioni
Quantity according to dimensions

ACX.08.71 SX-DX

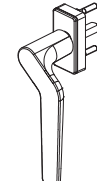

N° 2
Martellina SX disassata
Offset handle

ASX.85.02**
N° 2 Kit

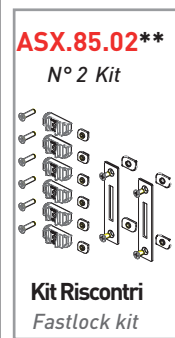

Kit Riscontri
Fastlock kit

*** ASX 12.VASCH**
Vaschetta drenaggio
Drainage system



* Quantità secondo dimensioni
Quantity according to dimensions

ASX.08.74

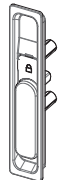

N° 2
Maniglia ad incasso
Embedded handle

ASX 12.ANGFIS



Anta fissa-Fixed Sash
ASX12.ANGFIS

Solo Fisso c/ Mobile
Only fixed Sash w/Mobile Sash

** Secondo preferenza - As per Choice

SCORREVOLE A 3 ANTE

3 Binari

SLIDING WITH 3 DOORS
3 Rails

Anta / Sash
SX85.201

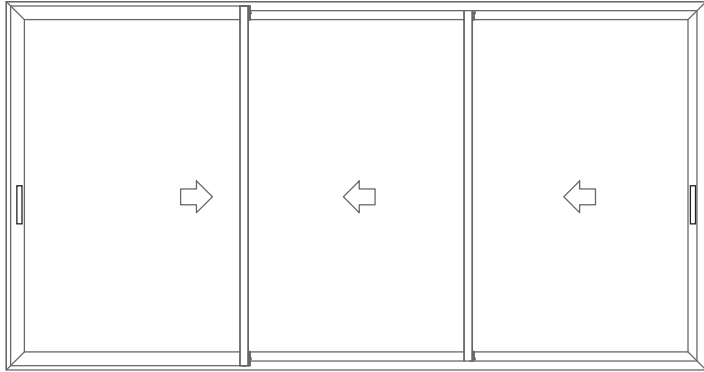

Distinta di taglio vetri
Glass cutting list

Q.tà	H	L
3	H - 177	L/3 - 61.5

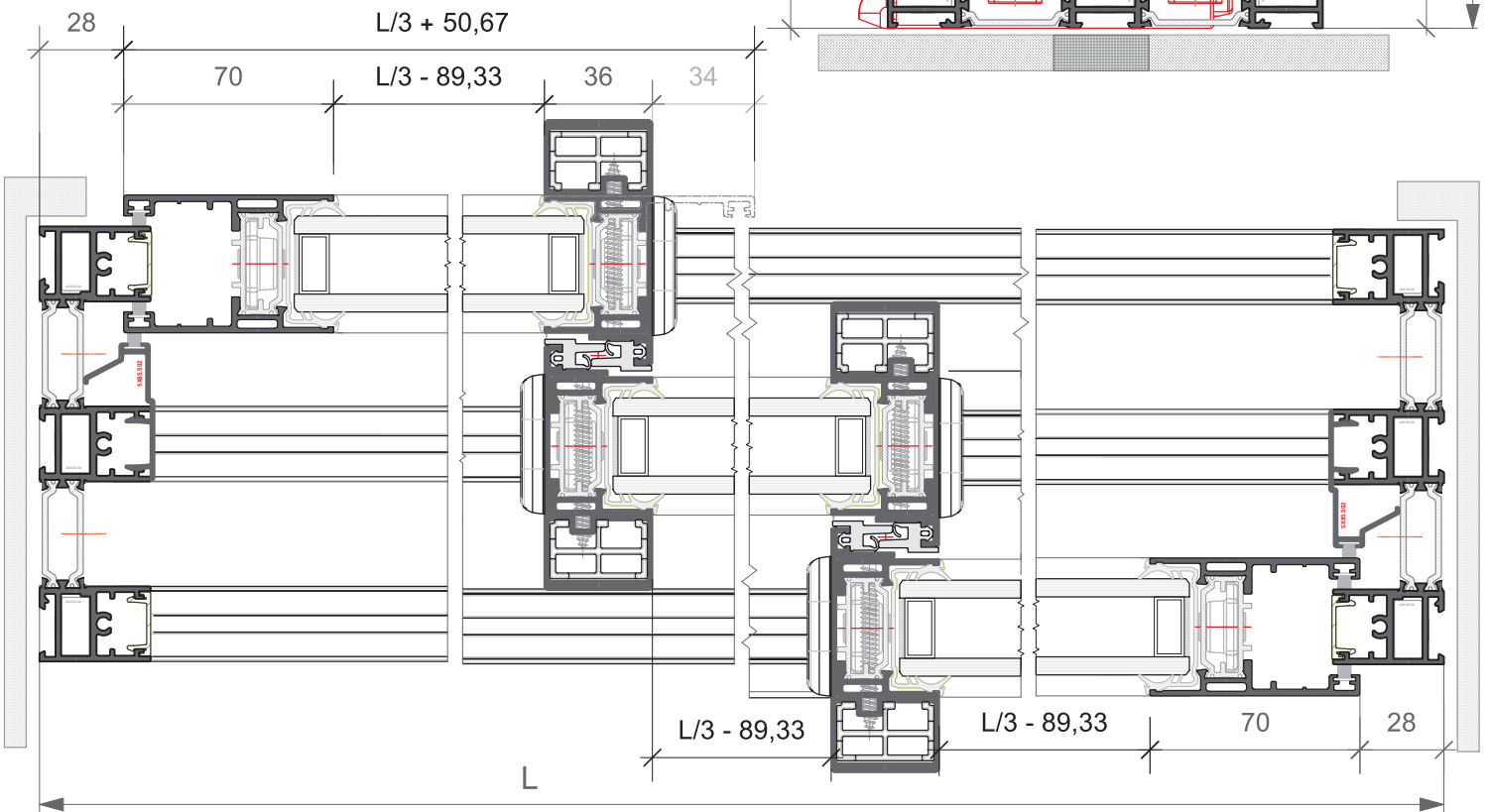
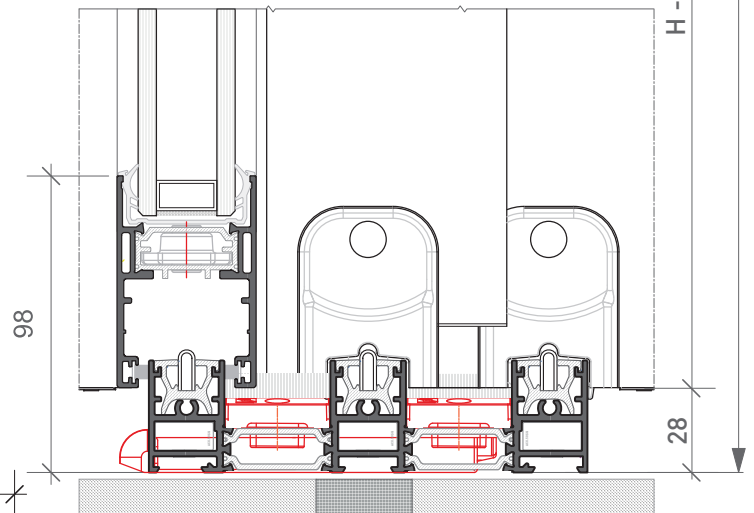
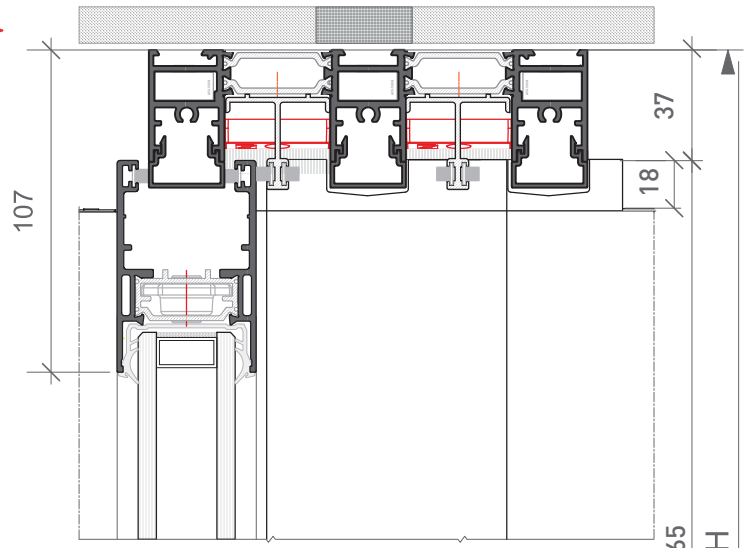
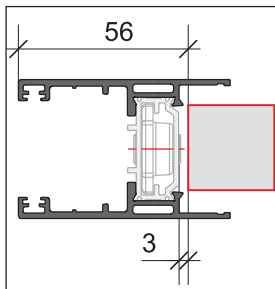





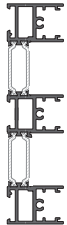
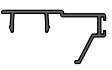
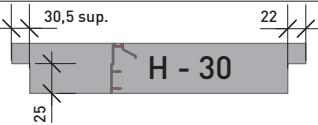

SCORREVOLE A 3 ANTE

3 Binari

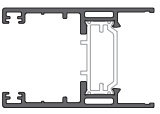
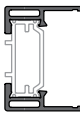
SLIDING WITH 3 DOORS
3 Rails

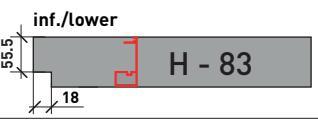
Distinta di Taglio | *Cutting List*

Profilo Profile	Taglio CUT	Qt.
 SX85.102	L H	2 2
 SX85.502	 H - 30	2
 ASX15.02	L -77 L -74	1 2
 BX09	L -77 L -74	1 2
 SX85.201	L/3+ 50,77 H - 65	6 2
 SX85.204	H-137	4
 SX12.301	H - 83  inf./lower	2 2
 SX85.301	L/3 + 5 L2/3 - 79	3 3
 BX53	L/3 - 47.5 L2/3 - 77.5	2 2

Guarnizioni

ASX 10.74	Guarn. vetro inserire mm.32 Gasket for glass mm. 32	6H+2L
ASX 10.72	Guarnizione profilo centrale Central profile gasket	4H
ASX 10.34 o ASX 10.69	Guarnizione tenuta anta Sealing gasket door	6H+8L
ASX 10.26	Barretta coprirotaia Rail cover bar	4H

Distinta Accessori | *Accessories List*

N°1 ASX.85.K2AMG
Kit Mobile+ Mobile Anta magg.
2 Sliding Sashes kit - 240 Kg Sash

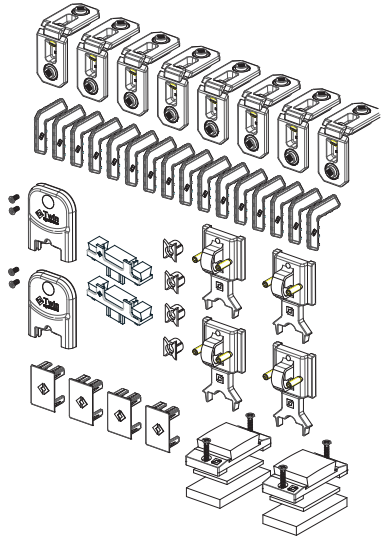

N° 3 ASX 85.CARMAG
Cp. carrello bilanciato regist. 240 Kg anta
Balanced adjustable roller 240 Kg Sash

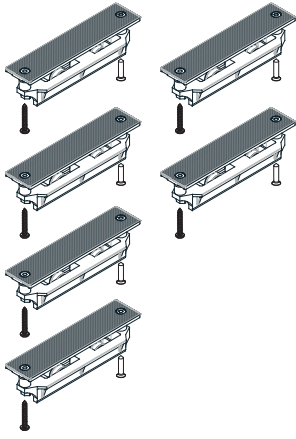

N° 1 ASX.85.K3AM
Kit aggiuntivo 3^ anta su 2 binari
Additional Kit Three tracks 2rd sash

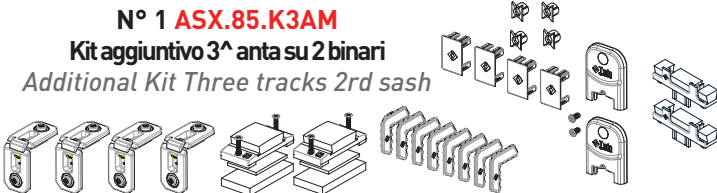

ACX 50.SQ
N° 12
Squadretta telaio
Corner joint frame



ASX 13.02**
N° 2 Kit
Fastlock su anta
H min. 750 mm.
Fastlock on Sash
H min. 750 mm



*** ARX 06.01**
Registro telaio
Frame adjuster



* Quantità secondo dimensioni
Quantity according to dimensions

ACX.08.71 SX

N° 1
Martellina SX disassata
Offset handle

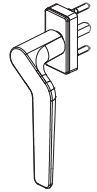

ASX.85.02**
N° 2 Kit

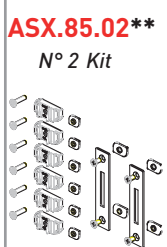

*** ASX 12.VASCH**
Vaschetta drenaggio
Drainage system



Quantità secondo dimensioni
Quantity according to dimensions

ASX.08.74

N° 1
Maniglia ad incasso
Embedded handle

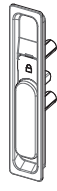

Kit Riscontri
Fastlock kit



Anta fissa-Fixed Sash
ASX12.ANGFIS



Solo Fisso c/ Mobile
Only fixed Sash w/Mobile Sash

** Secondo preferenza - As per Choice



SCORREVOLE A 4 ANTE

SLIDING DOOR WITH 4 DOORS



Anta / Sash
SX85.201

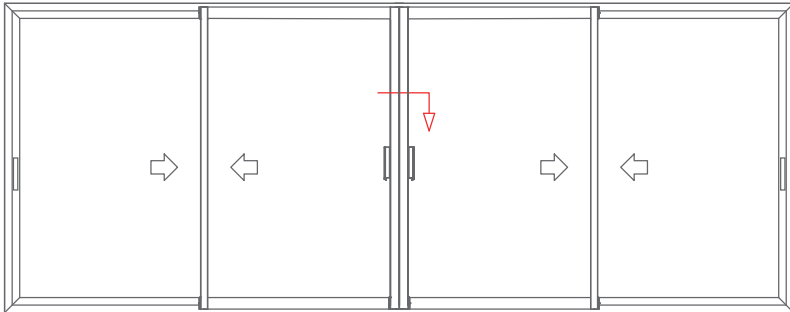

Distinta di taglio vetri
Glass cutting list



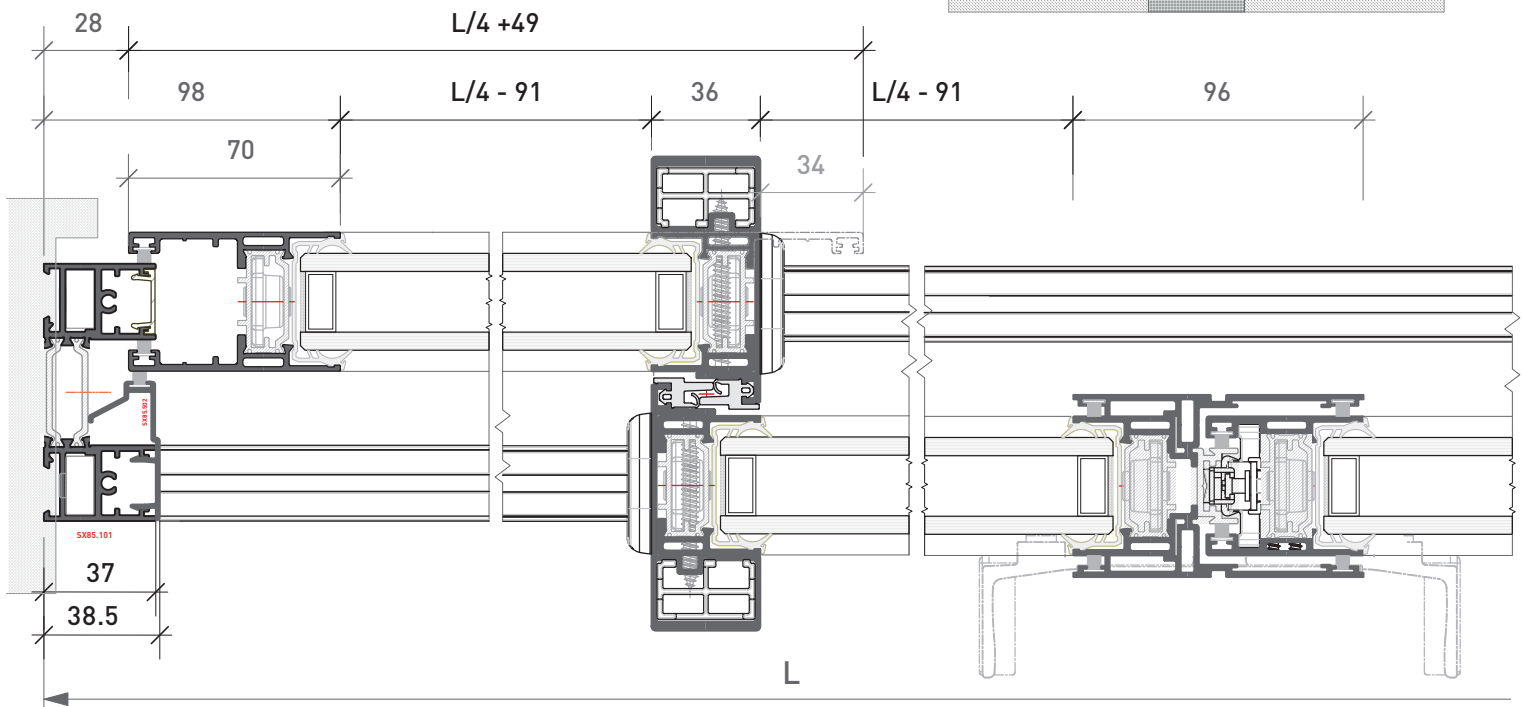
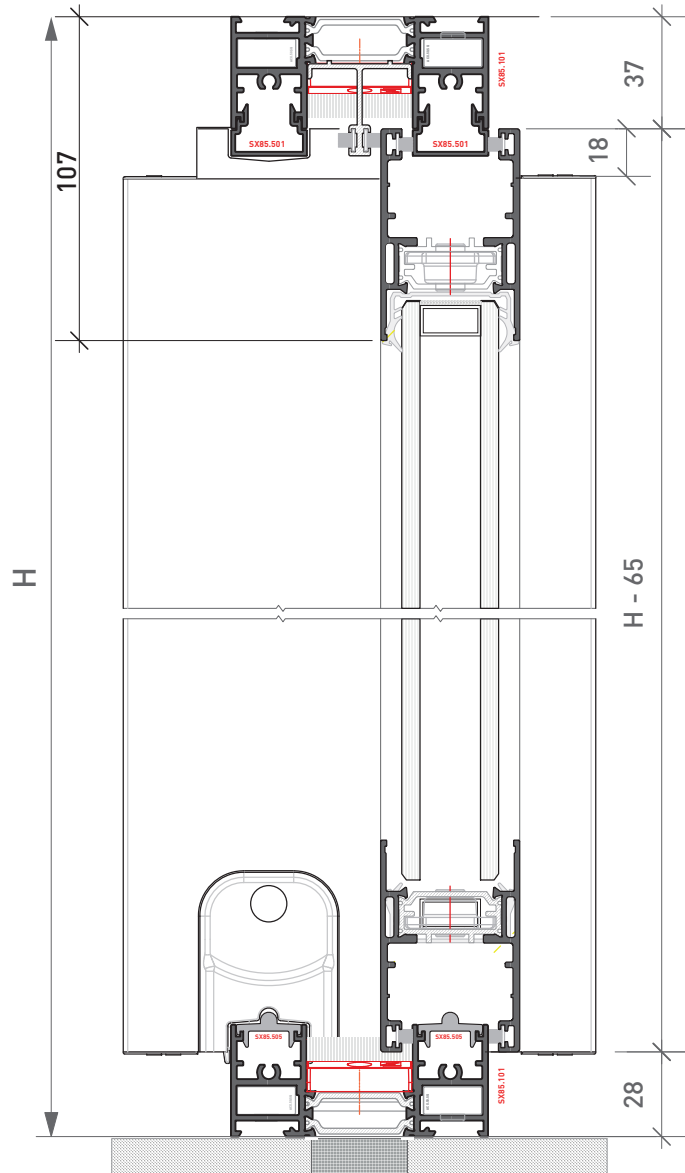
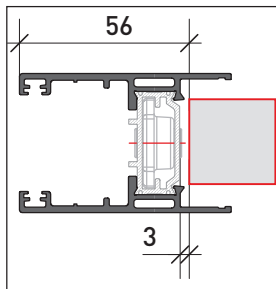





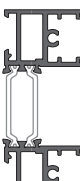

Q.tà	H	L
4	H - 177	L/4 - 63

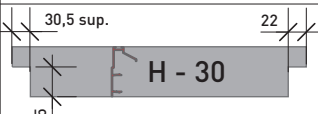

SCORREVOLE A 4 ANTE

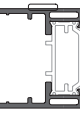
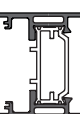
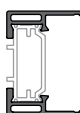
SLIDING DOOR WITH 4 DOORS

Distinta di Taglio | *Cutting List*

Profilo Profile	Taglio CUT	Qt.
 SX85.101	 L	2
	 H	2
 SX85.502	 H - 30	2
 SX85.505	L - 77	1
	L - 74	1
 SX85.201	L/4 + 49	8
	H - 65	2
 SX12.203	H - 101	1
 SX85.204	H - 137	5
 SX85.301	H - 83	4
 SX85.501	L/3 - 235	4
	L/3 + 396	2
 SX12.303	H - 65	2
 BX53	L/4 - 49	2
	L/2 - 121	1
Guarnizioni		
ASX 10.74	Guarn. vetro inserire mm.32 Gasket for glass mm. 32	8H+2L
ASX 10.72	Guarnizione profilo centrale Central profile gasket	4H
ASX 10.34 o ASX 10.69	Guarnizione tenuta anta Sealing gasket door	12H+6L
ASX 10.26	Barretta per inox Bar for stainless steel rail	2H

Distinta Accessori | *Accessories List*

N°2 ASX.85.K2AMG
Kit Mobile+ Mobile Anta magg.
2 Sliding Sashes kit - 240 Kg Sash



N° 4 ASX 85.CARMAG
Cp. carrello bilanciato regist. 240 Kg anta
Balanced adjustable roller 240 Kg Sash



N° 1 ASX.85.K4AM
Kit tappi 4^ anta
4rd sash Cap Kit



ACX 50.SQ
N° 8
Squadretta telaio
Corner joint frame



ASX 13.02**
N° 3 Kit
Fastlock su anta
H min. 750 mm.
Fastlock on Sash
H min. 750 mm



*** ARX 06.01**
Registro telaio
Frame adjuster



* Quantità secondo dimensioni
Quantity according to dimensions

ASX 12.MTMSX
1 Pz. KIT Maniglia SX
1 Pc. LX Handle KIT



ASX.85.07**
N° 3 Kit



*** ASX 12.VASCH**
Vaschetta drenaggio
Drainage system



* Quantità secondo dimensioni
Quantity according to dimensions

ASX 12.MTF
1 Pz. Maniglia traino fissa
1 Pc. FIXED train handle



ASX.08.74



KIT Ricontri
Fastlock kit

**

N° 2
Maniglia ad incasso
Embedded handle

Anta fissa-Fixed Sash
ASX12.ANGFIS



Solo Fisso c/ Mobile
Only fixed Sash w/Mobile Sash

** Secondo preferenza - As per Choice

SCORREVOLE A 4 ANTE CON ANGOLO

SLIDING DOOR WITH 4 DOORS WITH CORNER

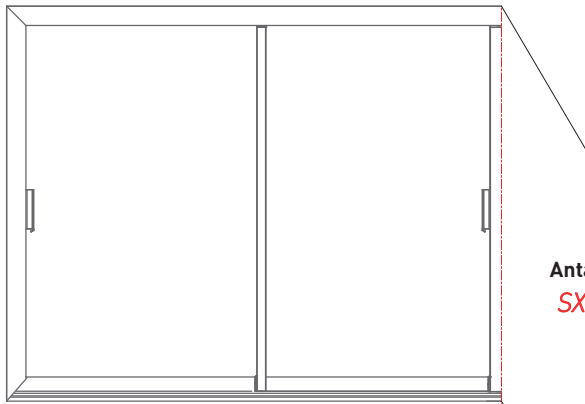

Anta / Sash
SX85.201

Distinta di taglio vetri
Glass cutting list

Q.tà	H	L
4	H - 177	L/2 - 111

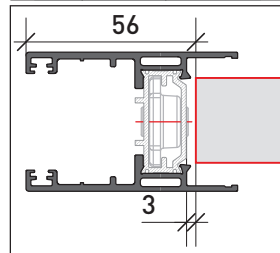

L/2 + 1



28

70

34

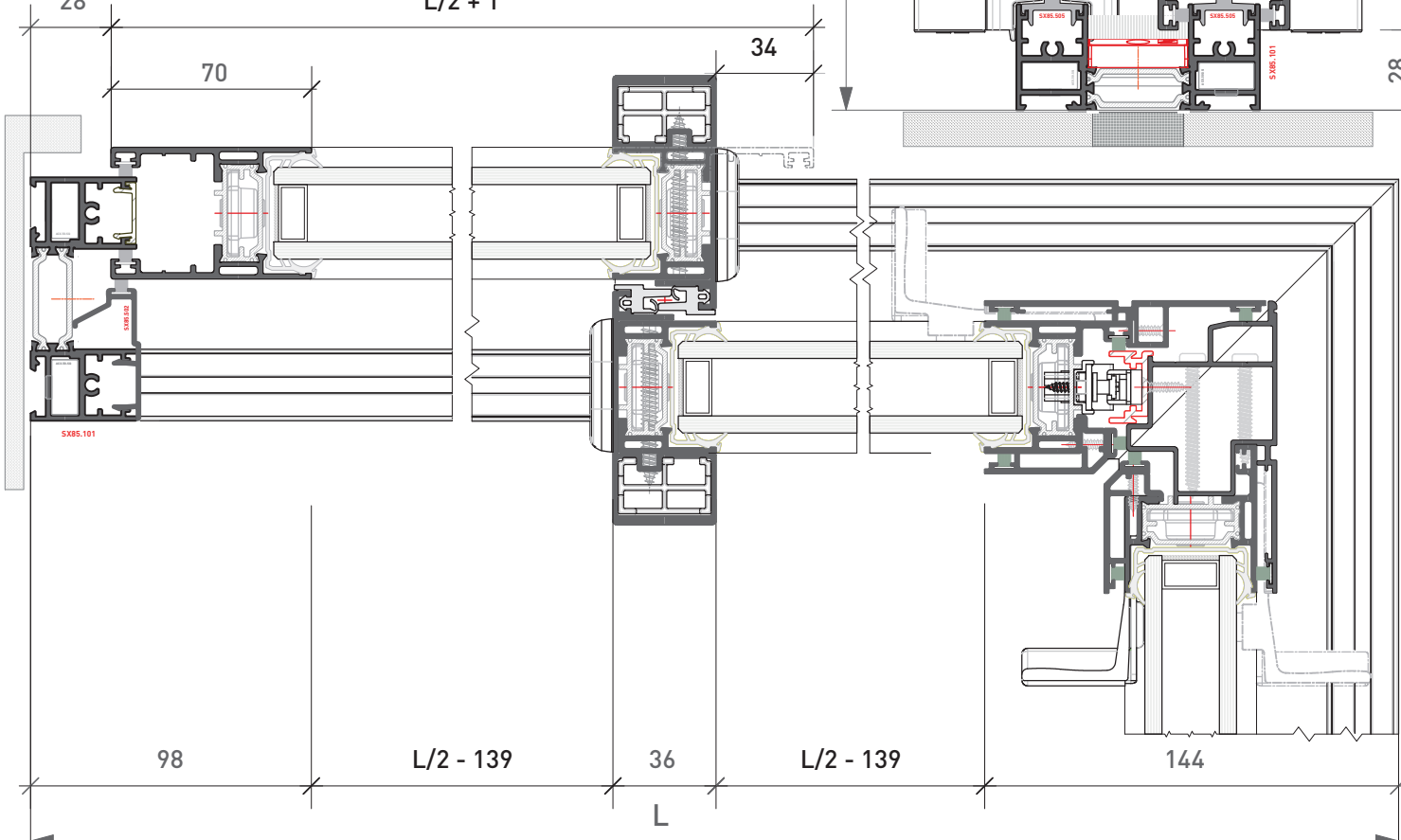
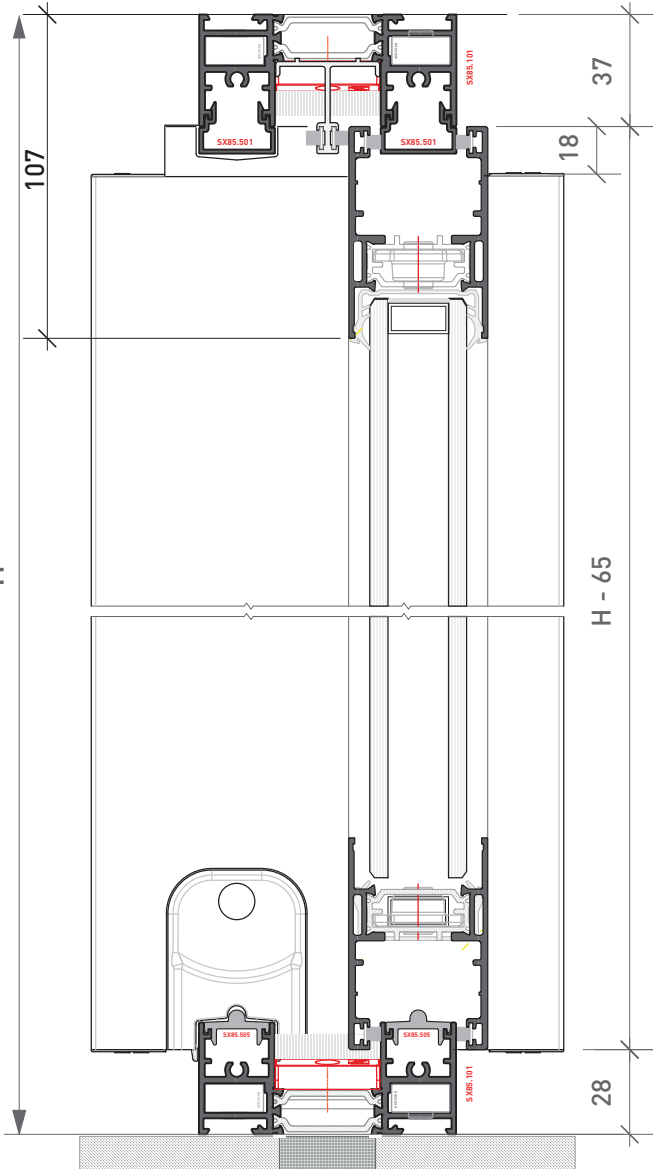

SCORREVOLE A 4 ANTE











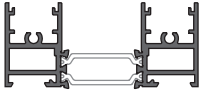



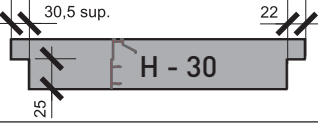



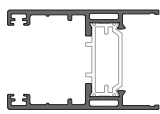
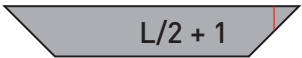

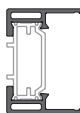





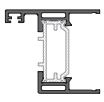

ad ANGOLO

CORNER WITH 4 SLIDING SASHES

Distinta di Taglio | *Cutting List*

Distinta Accessori | *Accessories List*



Profilo <i>Profile</i>	Taglio <i>CUT</i>	Qt.
 SX85.101	 L  L  H	2 2 2
 SX85.502	 30,5 sup. 22 H - 30 25	2
 SX85.505	 L - 100,5  L - 45	2 2
 SX85.201	 L/2 + 1  H - 65	8 2
 SX85.204	 H - 137	4
 SX85.301	 H - 83	4
 SX85.501	 L - 37  L - 97	2 2
 SX12.205	 H - 101	2
 SX12.306	 H - 65	1
 SX12.304	 H - 65	2
 SX12.305	 H - 65	1
 BX 53	 H - 97  H - 38	2 2
 BX 30	 H - 96	2

N°2 ASX.85.K2AMG
Kit Mobile + Mobile Anta magg.
2 Sliding Sashes kit - 240 Kg Sash

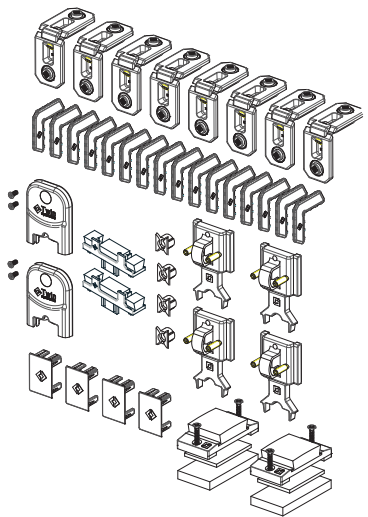

N° 4 ASX 85.CARMAG
Cp. carrello bilanciato regist. 240 Kg anta
Balanced adjustable roller 240 Kg Sash

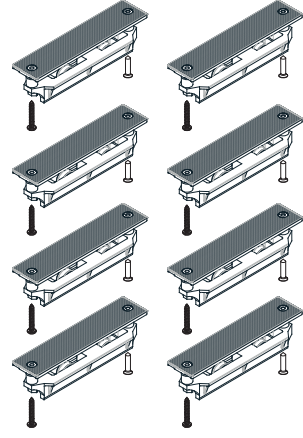

ASX.85.KANG
Kit soluzione angolare DX-SX
RIGHT-LEFT corner solution kit

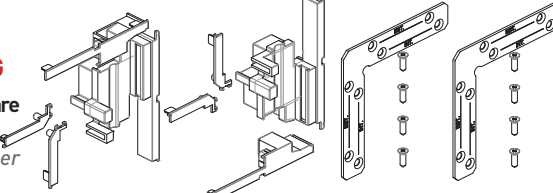

ACX 50.SQ
N° 8
Squadretta telaio
Corner joint frame

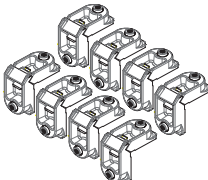

ASX 13.02**
N° 3 Kit
Fastlock su anta
H min. 750 mm.
Fastlock on Sash
H min. 750 mm

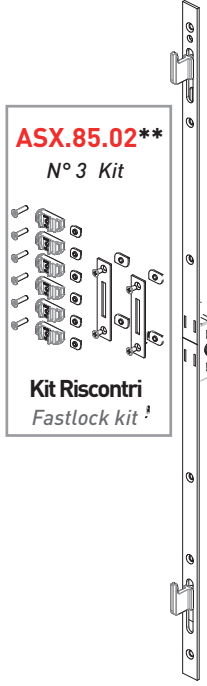

*** ARX 06.01**
Registro telaio
Frameadjuster



* Quantità secondo dimensioni
Quantity according to dimensions

ASX 12.MTMSX o DX
1 Pz. KIT Maniglia SX or DX
1 Pz. LX or DX Handle KIT



ASX.85.02**
N° 3 Kit

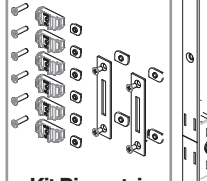

Kit Riscontri
Fastlock kit

*** ASX 12.VASCH**
Vasche a drenaggio
Drainage system



* Quantità secondo dimensioni
Quantity according to dimensions

ASX 12.MTF
1 Pz. Maniglia traino fissa
1 Pz. FIXED train handle

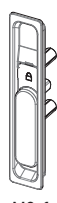

N° 1
Maniglia ad incasso
Embedded handle

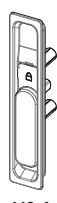

Anta fissa-Fixed Sash
ASX12.ANGFIS

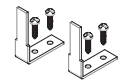

Solo Fisso c/ Mobile
Only fixed Sash w/Mobile Sash

** Secondo preferenza - *As per Choice*

SCORREVOLE ALZANTE 2 ANTE
SLIDE & LIFT 2 SASHES
SX85.204

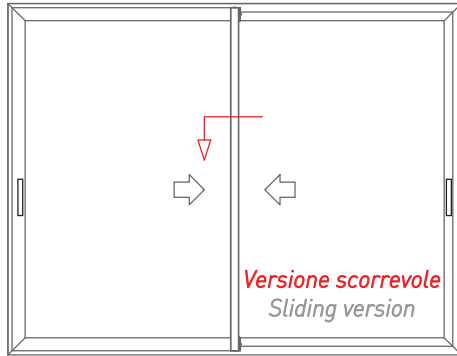

Distinta di taglio vetri
Glass cutting list

Q.tà	H	L
2	H - 193	L/2 - 96

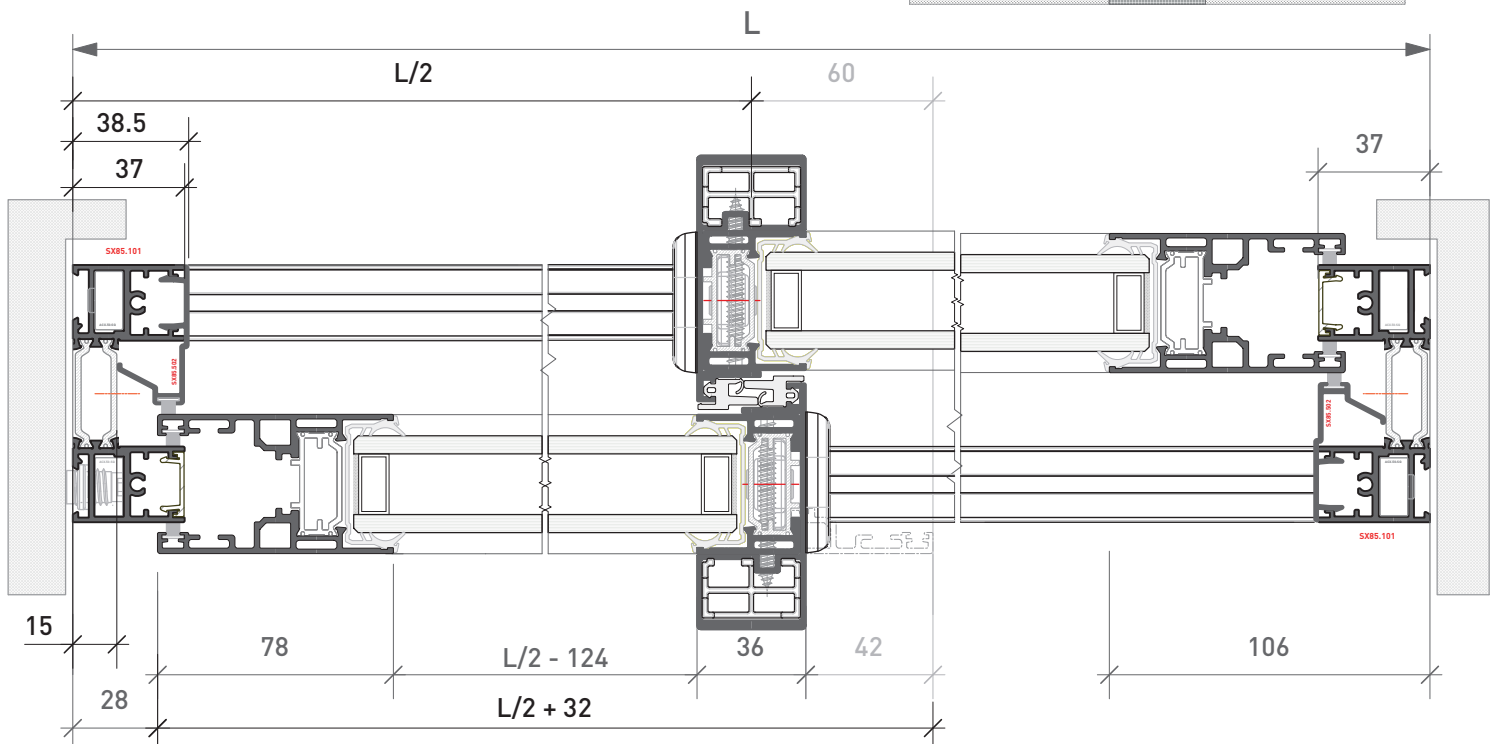
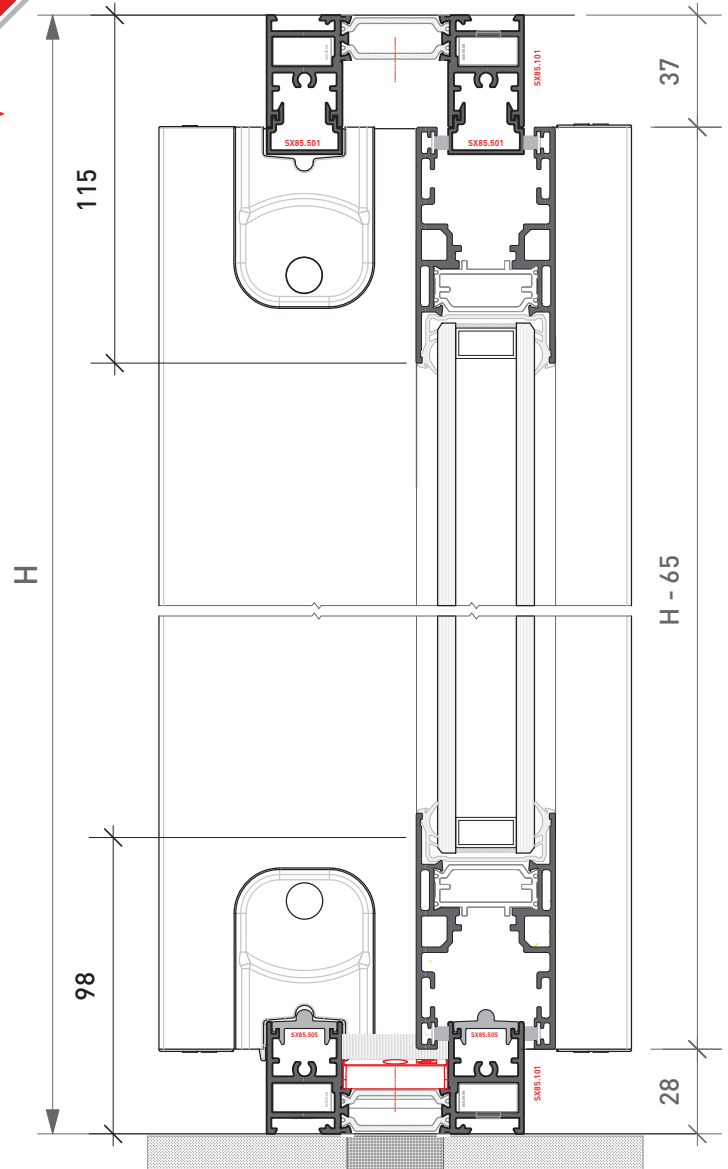
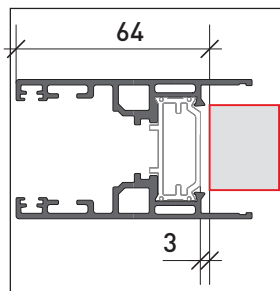





SCORREVOLE A 2 ANTE

SLIDING DOOR WITH 2 DOORS

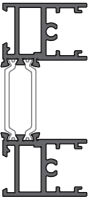

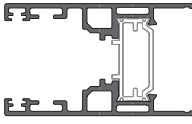
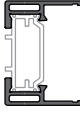
Distinta di Taglio | *Cutting List*

Profilo Profile	Taglio CUT	Qt.
 SX85.101	L H	2 2
 SX85.502	H - 30 25	2
 SX85.505	L - 75.5	2
 SX85.204	L/2 + 32 H - 65	4 2
 SX12.204	H - 153	2
 SX12.301	H - 65	2
 SX85.501	L - 75.5	2

Guarnizioni

ASX 10.74	Guarn. vetro inserire mm.32 Gasket for glass mm. 32	4H+2L
ASX 10.72	Guarnizione profilo centrale Central profile gasket	2H
ASX 10.34 o ASX 10.69	Guarnizione tenuta anta Sealing gaskeet door	6H+4L
ASX 10.26	Barretta coprirotaia Rail cover bar	2H

Distinta Accessori | *Accessories List*

N°1 ASX.85.K2ALZ
Kit Mobile+ Mobile Anta SX85.204
2 Sliding Sashes kit

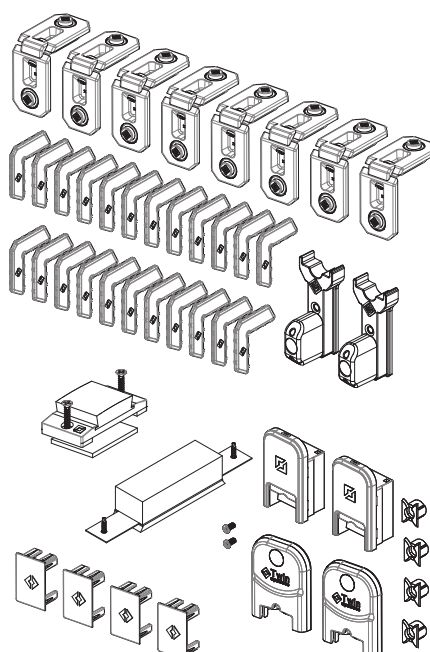

N° 2 ASX 85.CAR.ALZ
Coppia Carrelli Anta SX85.204 Scorrevole
Pair of Carriers for Slide Sash SX85.204

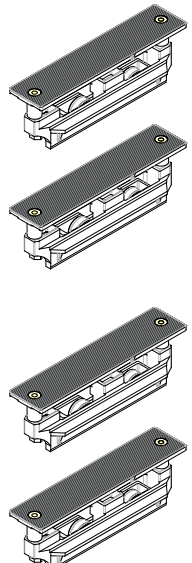

ACX 50.SQ
N° 8
Squadretta telaio
Corner joint frame



ASX 13.02**
N° 2 Kit
Fastlock su anta
H min. 750 mm.
Fastlock on Sash
H min. 750 mm



*** ARX 06.01**
Registro telaio
Frame adjuster



* Quantità secondo dimensioni
Quantity according to dimensions

ACX.08.71 SX

N° 1
Martellina SX disassata
Offset handle

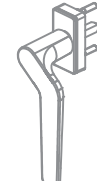

ASX.85.07**
N° 2 Kit

Kit Riscontri
Fastlock kit

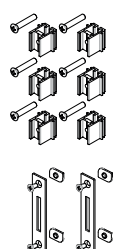

*** ASX 12.VASCH**
Vaschetta drenaggio
Drainage system



* Quantità secondo dimensioni
Quantity according to dimensions

ASX.08.74

N° 1
Maniglia ad incasso
Embedded handle



Anta fissa-Fixed Sash
ASX12.ANGFIS



Solo Fisso c/ Mobile
Only fixed Sash w/Mobile Sash

** Secondo preferenza - As per Choice

SCORREVOLE ALZANTE 2 ANTE
SLIDE & LIFT 2 SASHES
SX85.204

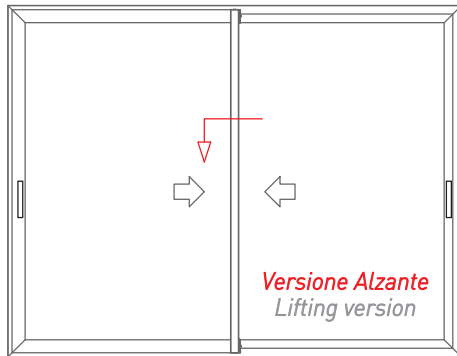

Distinta di taglio vetri
Glass cutting list

Q.tà	H	L
2	H - 193	L/2 - 96

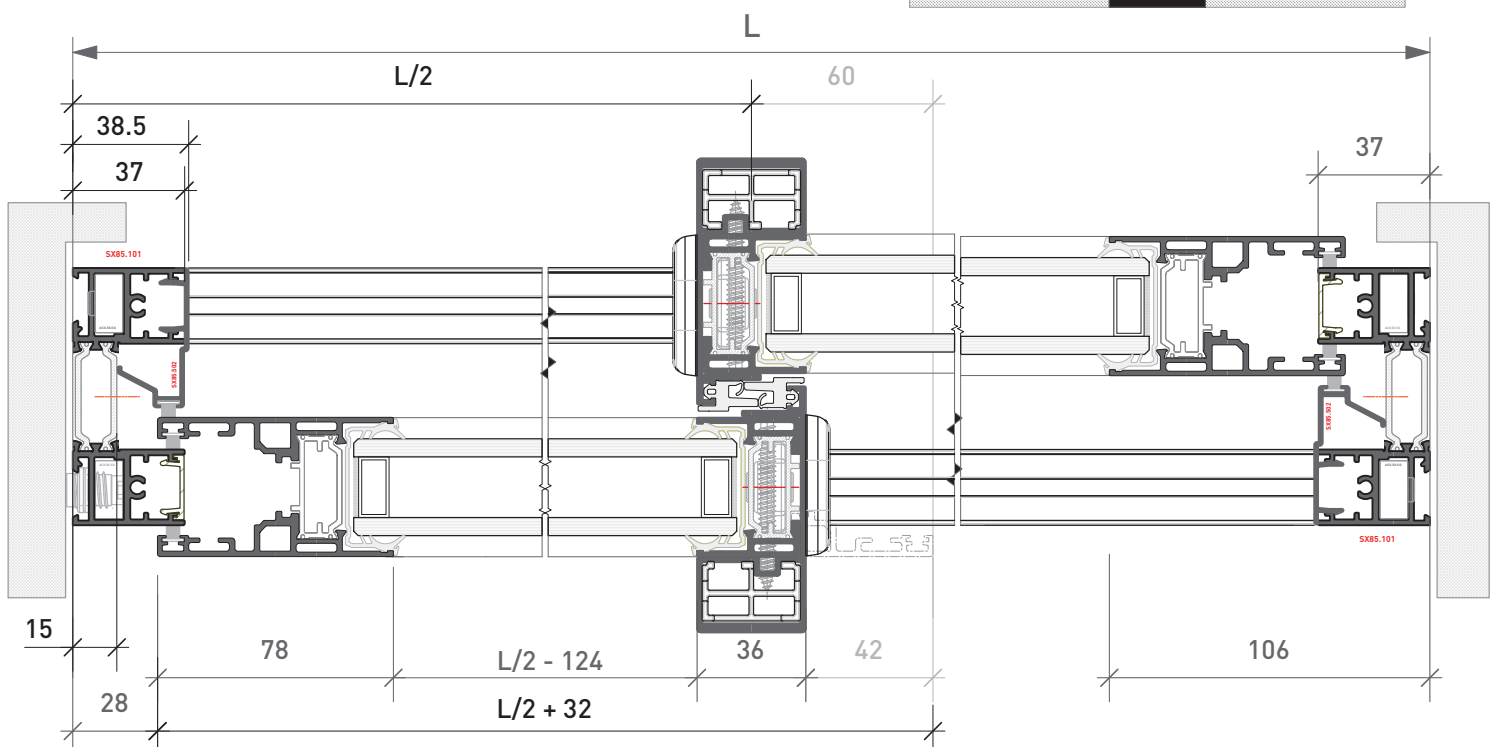
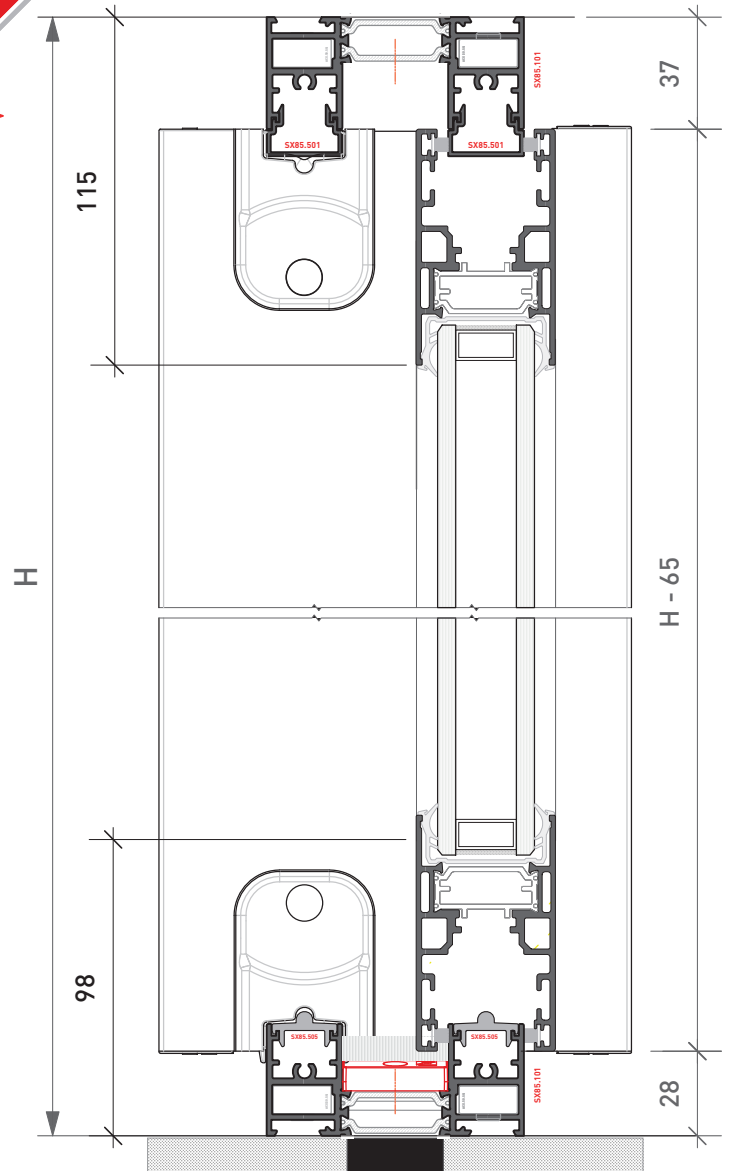
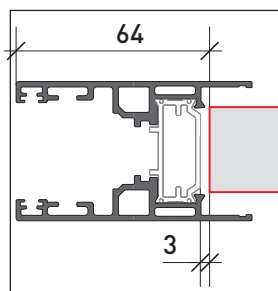





SCORREVOLE A 2 ANTE

SLIDING DOOR WITH 2 DOORS

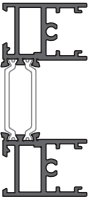

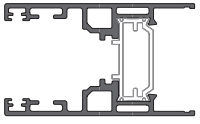
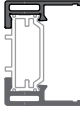
Distinta di Taglio | Cutting List

Profilo <i>Profile</i>	Taglio <i>CUT</i>	Qt.
 SX85.101	L H	2 2
 SX85.502	H - 30	2
 SX85.505	L - 75.5	2
 SX85.204	L/2 + 32 H - 65	4 2
 SX12.204	H - 153	2
 SX12.301	H - 65	2
 SX85.501	L - 75.5	2

Guarnizioni

ASX 10.74	Guarn. vetro inserire mm.32 <i>Gasket for glass mm. 32</i>	4H+2L
ASX 10.72	Guarnizione profilo centrale <i>Central profile gasket</i>	2H
ASX 10.34 o ASX 10.69	Guarnizione tenuta anta <i>Sealing gaskeet door</i>	6H+4L
ASX 10.26	Barretta copirotaia <i>Rail cover bar</i>	2H

Distinta Accessori | Accessories List

N°1 ASX.85.K2ALZ
KitM obile+ Mobile Anta magg. - 240 Kg anta
2 Sliding Sashes kit - 240 Kg Sash

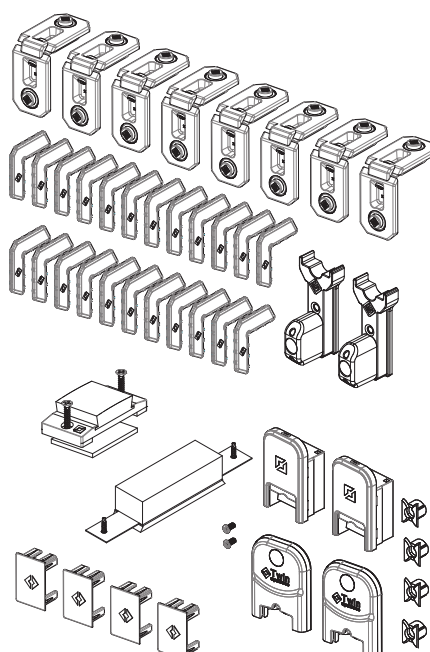

ACX 50.SQ
N° 8
Squadretta telaio
Corner joint frame



*** ARX 06.01**
Registro telaio
Frame adjuster



*** Quantità secondo dimensioni**
Quantity according to dimensions

*** ASX 12.VASCH**
Vaschetta drenaggio
Drainage system



*** Quantità secondo dimensioni**
Quantity according to dimensions

ALZANTE AS 200 - AS 200 lifting mechanism

Kit cremonese Regolabile
Adjustable Cremone Kit

Articolo/Item	Campo di applicazione <i>Application range</i>		
	H min	H max	N°chiusure <i>No. of locks</i>
ASX.16.00R	1175	1775	2
ASX.16.01R	1776	2275	3
ASX.16.02R	2276	2675	3



Per quantità ed accessori aggiuntivi consultare la Tav. C11
For quantities and additional accessories please refer to Table C11

ASX.16.03 Kit carrelli - Trolley kit	ASX.16.30 Contropiastra - Striker plate	ASX.16.20 Martellina ITALIA 7 mm. <i>Handle "ITALY" 7 mm.</i>
---	--	---

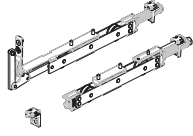
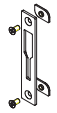
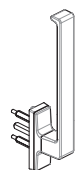
SCORREVOLE A 4 ANTE

SLIDING Sash WITH 4 DOORS

Anta / Sash **SX12.203** Centrale/Central Profile **SX11.303**

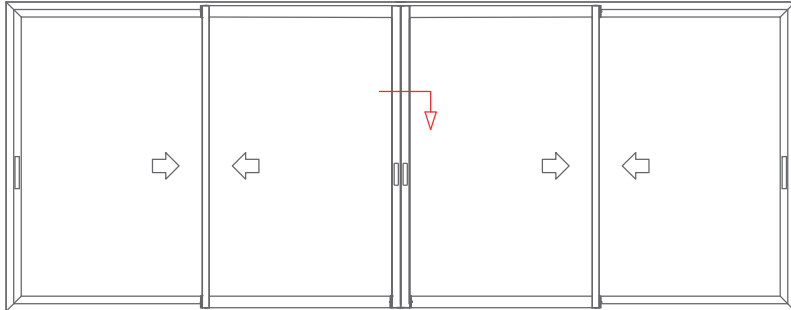

Distinta di taglio vetri
Glass cutting list



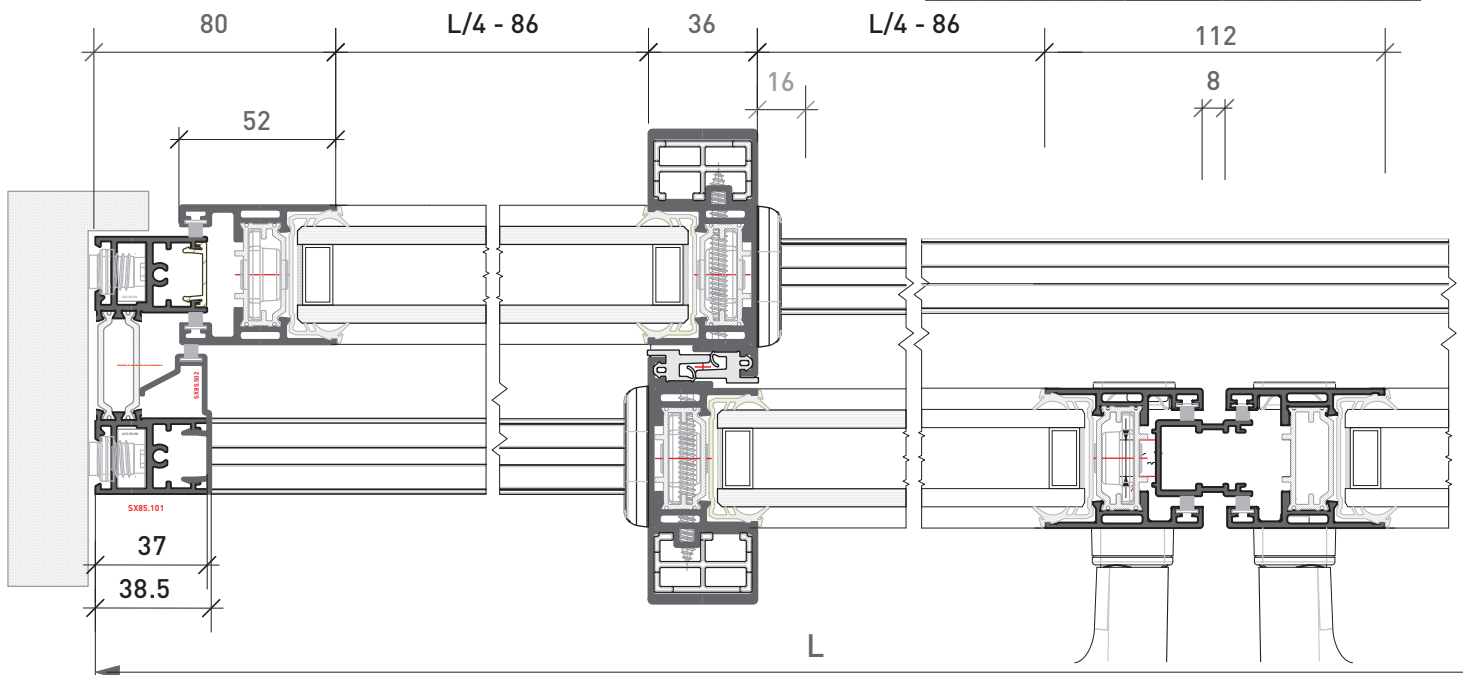
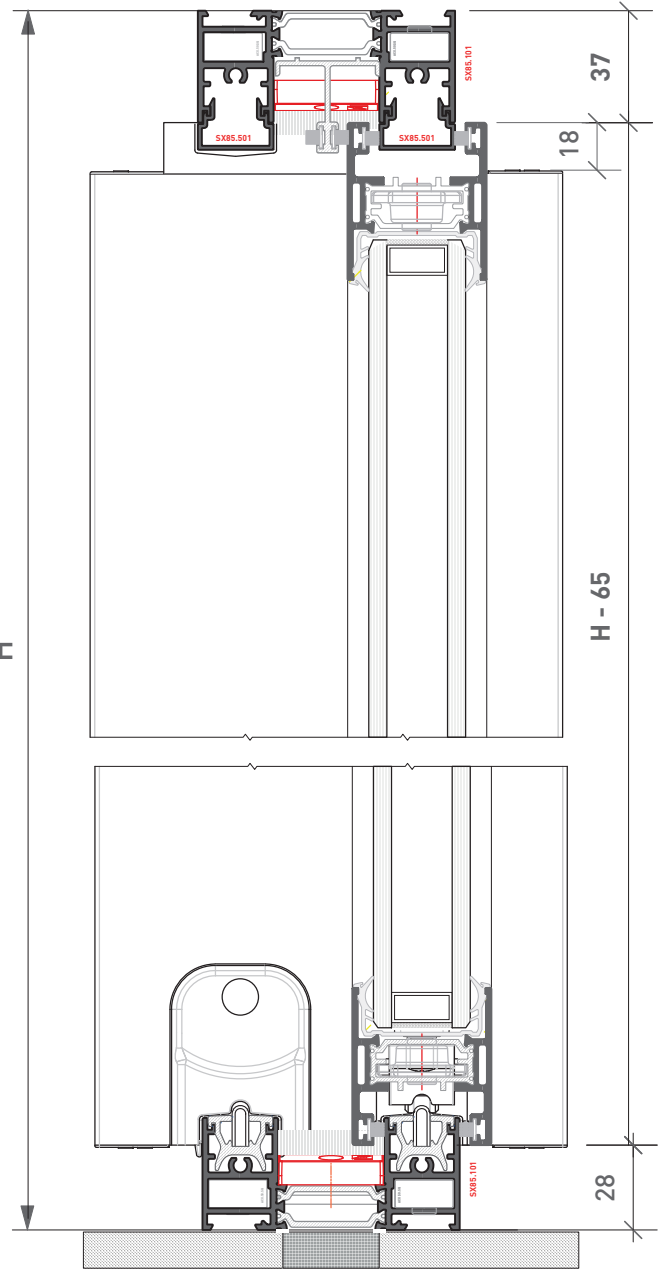
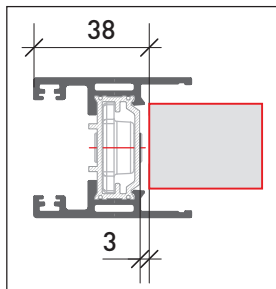







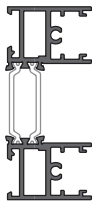



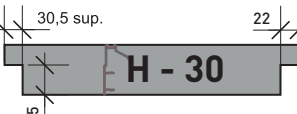





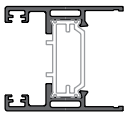

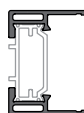

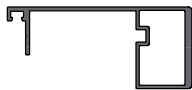
Q.tà	H	L
4	H - 141	L/4 - 58



SCORREVOLE A 4 ANTE

SLIDING Sash WITH 4 DOORS

Distinta di Taglio | *Cutting List*

Profilo <i>Profile</i>	Taglio <i>CUT</i>	Qt.
	 	2 2
SX85.101		
		2
SX85.502		
	 	1 1
ASX15.02		
	 	1 1
BX09		
	 	8 4
SX12.203		
		4
SX12.204		
		4
SX12.301		
	 	4 2
SX85.501		
		1
SX11.303		
	 	2 1
BX53		

Guarnizioni

ASX 10.74	Guarn. Inserire Vetro mm. 32 <i>Gasket to Insert 32 mm.</i>	8H+2L
ASX 10.72	Guarn. Profilo Centrale <i>Central Profile Gasket</i>	4H
ASX 10.34 o ASX 10.69	Guarn. di Tenuta Anta <i>Sash Sealing Gasket</i>	10H+6L
ASX 10.26	Barretta Cover <i>Rail Cover Bar</i>	2H

Distinta Accessori | *Accessories List*

N° 2 ASX 85.K2AM
Kit Mobile + Mobile

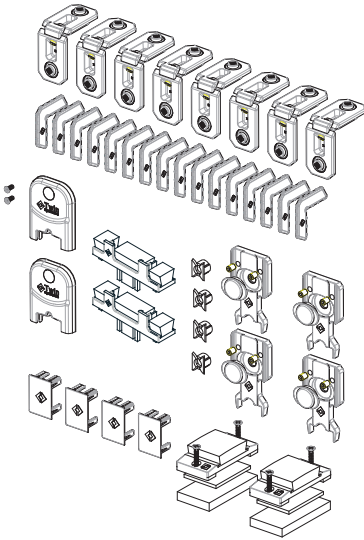

N° 4 ASX 85.CAR
Coppia carrello bilanciato regist.240 Kg anta
Balanced adjustable roller 240 Kg Sash

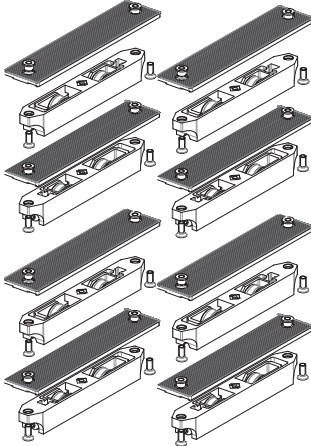

N° 1 ASX.07.10
Coppia Tappi Profilo SX11.303
Pair of Caps for SX11.303 Profile

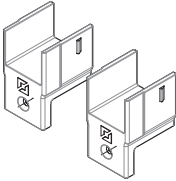

ACX 50.SQ
N° 8
Squadretta telaio
Corner joint frame

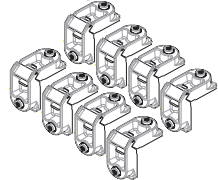

ASX 12.FAST60
N° 3 Kit Fastlock
600 mm.

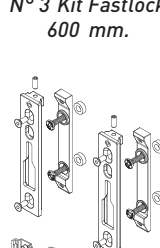

*** ARX 06.01**
Registro telaio
Frame adjuster



* Quantità secondo dimensioni
Quantity according to dimensions

ACX.08.60 n°2 pz.
Martellina
Martellina Handle

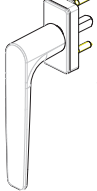

ASX.08.74

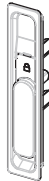

N° 2
*Maniglia ad incasso
Embedded handle*

Varianti

ASX 12.FAST100
N° 3 Kit
Fastlock 1000 mm.

ASX 12.FAST180
N° 3 Kit
Fastlock 1800 mm.

*** ASX 12.VASCH**
Vaschetta drenaggio
Drainage system



* Quantità secondo dimensioni
Quantity according to dimensions

Anta fissa-Fixed Sash
ASX12.ANGFIS



Solo Fisso c/ Mobile
Only fixed Sash w/Mobile Sash

ASX.08.73



N° 2 Maniglia di traino
External Pull Washer

** Secondo preferenza - *As per Choice*



SCORREVOLE A 4 ANTE

SLIDING DOOR WITH 4 DOORS

Anta / Sash
SX85.201

Centrale/Central Profile
SX11.303

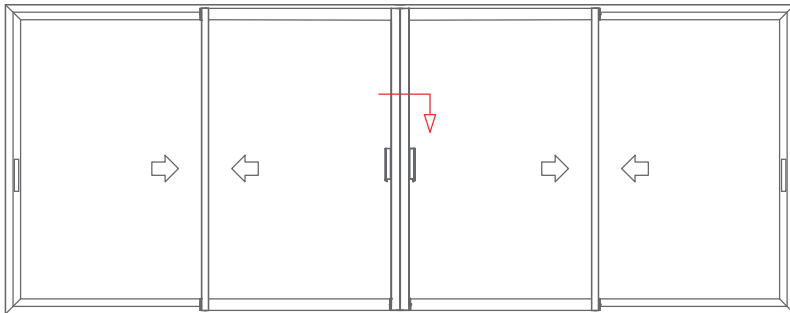

Distinta di taglio vetri
Glass cutting list



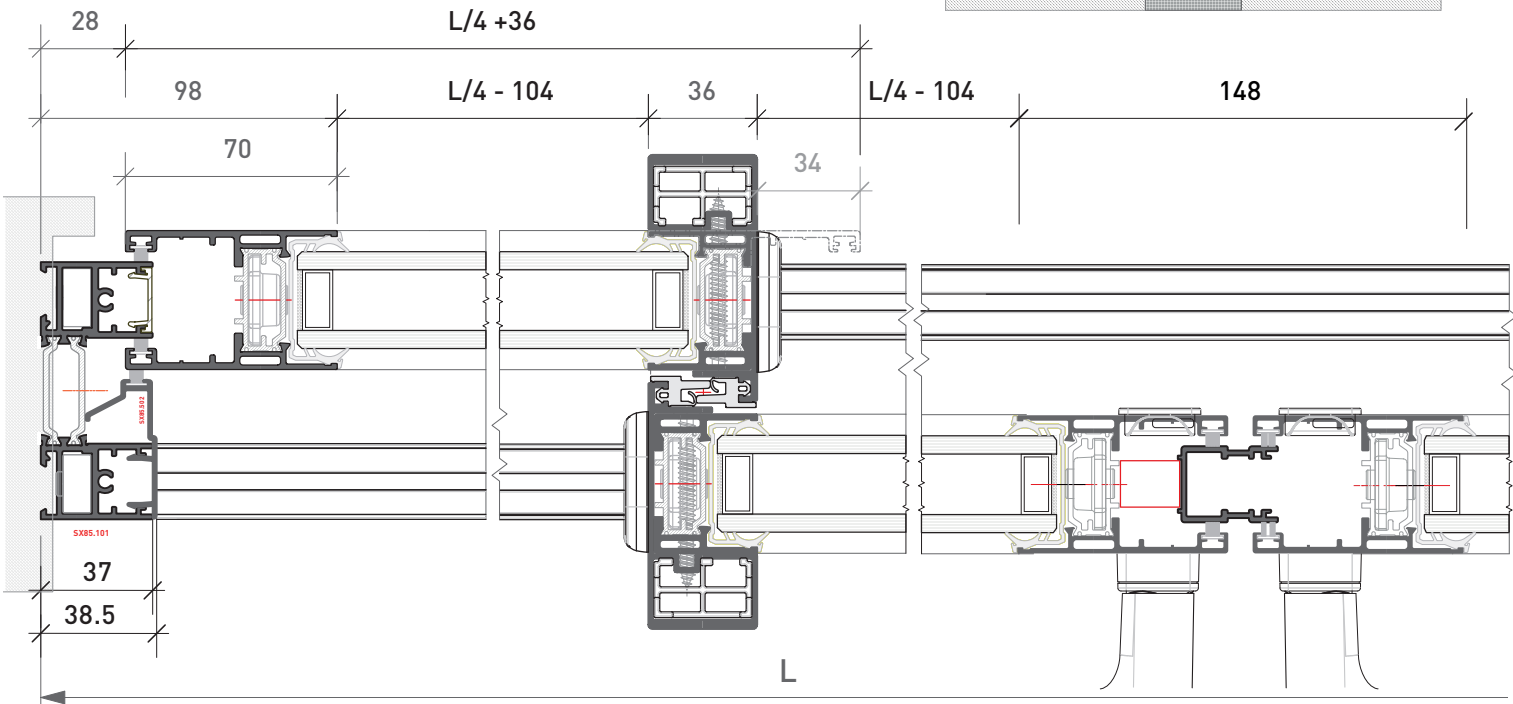
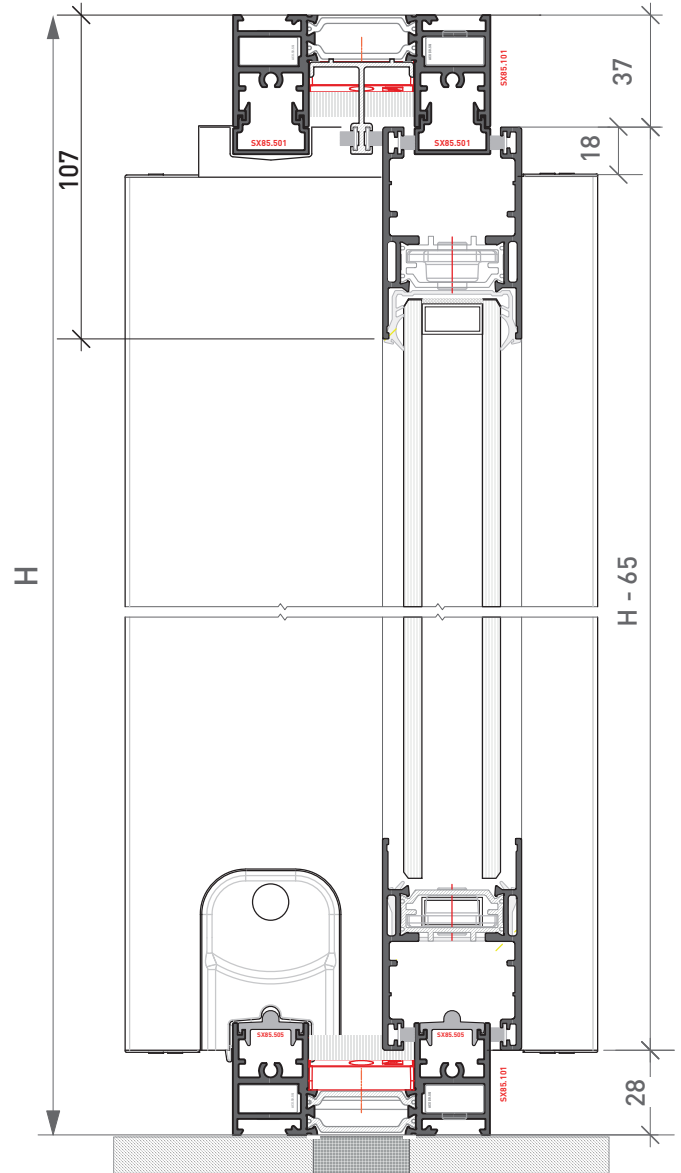
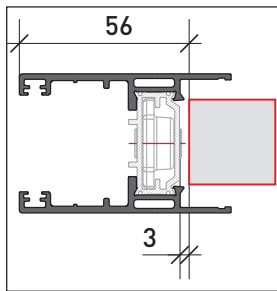





Q.tà	H	L
4	H - 177	L/4 - 76

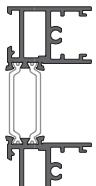

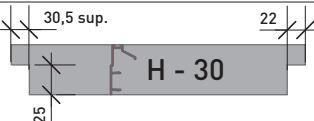
SCORREVOLE A 4 ANTE

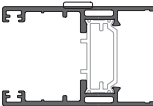
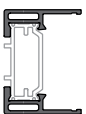
SLIDING DOOR WITH 4 DOORS

Distinta di Taglio | *Cutting List*

Profilo <i>Profile</i>	Taglio <i>CUT</i>	Qt.
 SX85.101	L H	2 2
 SX85.502	 H - 30	2
 SX85.505	L - 77 L - 74	1 1
 SX85.201	L / 4 + 36 H - 65	8 4
 SX85.204	H - 137	4
 SX11.303	H - 123	1
 SX85.301	H - 83	4
 SX85.501	L/3 - 235 L/3 + 396	4 2
 BX53	L/4 - 62 L/2 - 95	2 1

Guarnizioni

ASX 10.74	Guarn. vetro inserire mm.32 <i>Gasket for glass mm. 32</i>	8H+2L
ASX 10.72	Guarnizione profilo centrale <i>Central profile gasket</i>	4H
ASX 10.34 o ASX 10.69	Guarnizione tenuta anta <i>Sealing gasket door</i>	10H+6L
ASX 10.26	Barretta per inox <i>Bar for stainless steel rail</i>	2H

Anta fissa - *Fixed Sash*
ASX12.ANGFIS



Solo Fisso c/ Mobile
Only fixed Sash w/Mobile Sash

Distinta Accessori | *Accessories List*

N°2 ASX.85.K2AMG
Kit Mobile+ Mobile Anta magg.
2 Sliding Sashes kit - 240 Kg Sash

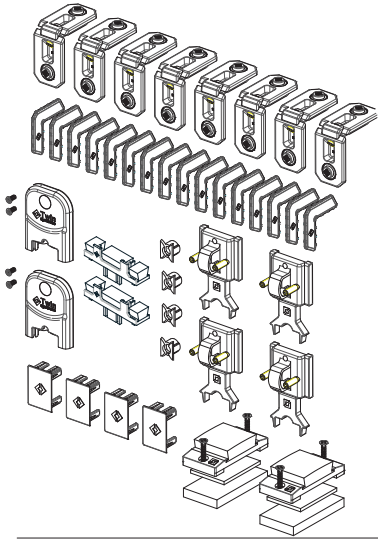

N° 4 ASX 85.CARMAG
Cp. carrello bilanciato regist. 240 Kg anta
Balanced adjustable roller 240 Kg Sash

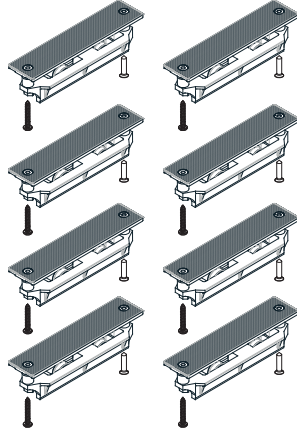

N° 1 ASX.07.10
Coppia Tappi Profilo SX11.303
Pair of Caps for SX11.303 Profile

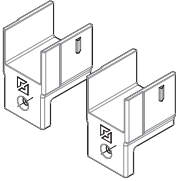

ACX 50.SQ
N° 8
Squadretta telaio
Corner joint frame

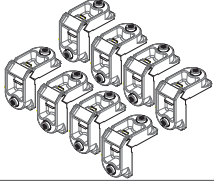

ASX 13.02**
N° 3 Kit
Fastlock su anta
H min. 750 mm.
Fastlock on Sash
H min. 750 mm

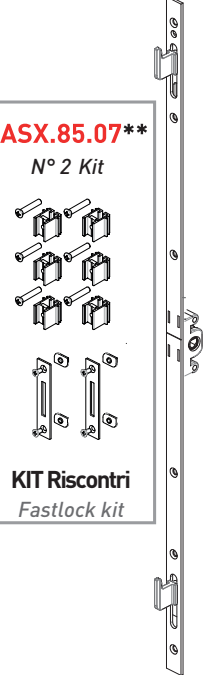

*** ARX 06.01**
Registro telaio
Frame adjuster



* Quantità secondo dimensioni
Quantity according to dimensions

ACX.08.60 n°2 pz.
Martellina
Martellina Handle

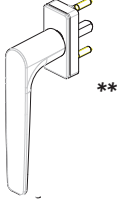

**

ASX.85.07**
N° 2 Kit

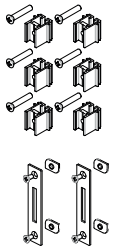

KIT Ricontri
Fastlock kit

*** ASX 12.VASCH**
Vaschetta drenaggio
Drainage system

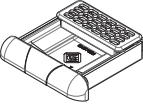

* Quantità secondo dimensioni
Quantity according to dimensions

ASX.08.74



**

N° 2
Maniglia ad incasso
Embedded handle

ASX.08.73



N° 2
Maniglia di traino
External Pull Washer

** Secondo preferenza - *As per Choice*



Attacco alla Muratura
Connection to Brickwork

Gruppo F

Sezione particolareggiata
attacco alla muratura

Wall Joint Detail







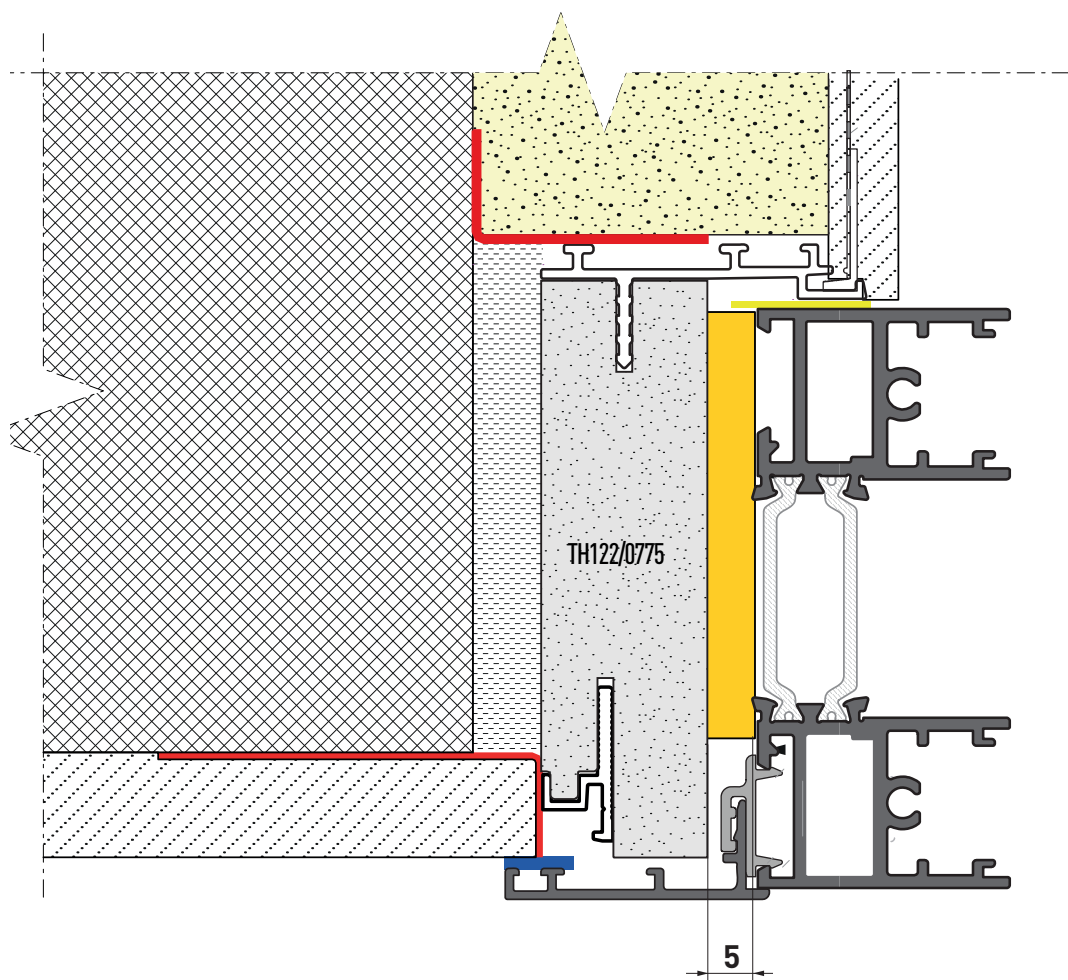

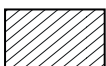

■ SEZIONE ORIZZONTALE

POSA QUALITÀ

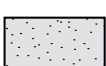
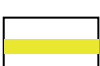

■ LEGENDA MATERIALI

	Muratura <i>Brickwall</i>		Nastro Multifunz. 54/10 PQ.1009.G <i>Munifunc. Tape 54/10 PQ.1009.G</i>		PQ.1012 Schiuma Poliuretanic <i>PQ.1012 Polyurethane Foam</i>
	Intonaco <i>Plaster</i>		PQ.1008 Nastro Autoadesivo 9x2 <i>PQ.1008 Auto-Adhesive Tape 9x2</i>		PQ.1003 Freno al Vapore [Pellicola Interna] 70 mm. <i>PQ.1003 Steam Barrier [Internal Film] 70 mm.</i>
	Isolamento <i>Insulation</i>		PQ.1007 Nastro 600Pa 15/1-4 <i>PQ.1007 Tape 600Pa 15/1-4</i>		PQ.1013 Profilo Portaintonaco <i>Plaster net profile</i>
	Controtelaio THERMAL <i>Wall frame THERMAL</i>		PQ.1011 Nastro PE 30x6 <i>PQ.1011 PE Tape 30x6</i>		



■ SEZIONE VERTICALE

■ LEGENDA MATERIALI

POSA QUALITÀ

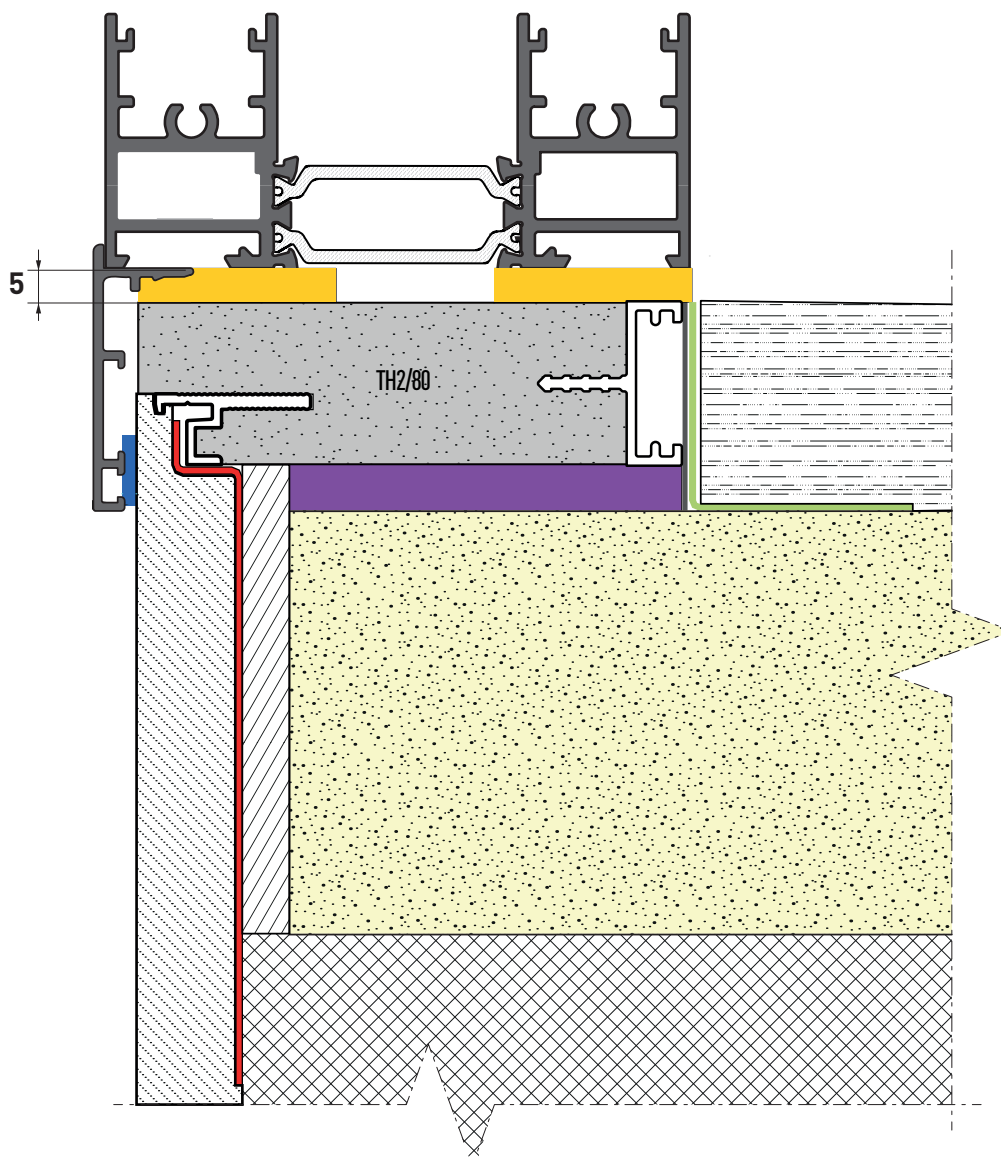

■ LEGENDA MATERIALI



Muratura
Brickwall



Intonaco
Plaster



Isolamento
Insulation



Controtelaio THERMAL
Wall frame THERMAL



Nastro Multifunz. 54/10 PQ.1009.G
Munifunc. Tape 54/10 PQ.1009.G



PQ.1003 Freno Vapore [PelL.Interna] 70 mm.
PQ.1003 Steam Barrier [Internal Film] 70 mm.



PQ.1012 Schiuma Poliuretanic
PQ.1012 Polyurethane Foam

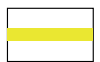

PQ.1007 Nastro 600Pa 15/1-4
PQ.1007 Tape 600Pa 15/1-4



PQ.1005 Guaina Estena EPDM 80 mm.
PQ.1003 External Sheath EPDM 80 mm.



Soglia
Threshold

► **CONTROTELAIO PERIMETRALE**
 ► **PERIMETRAL COUNTERFRAME**

Soluzione DUE VIE
TWO WAY Solution

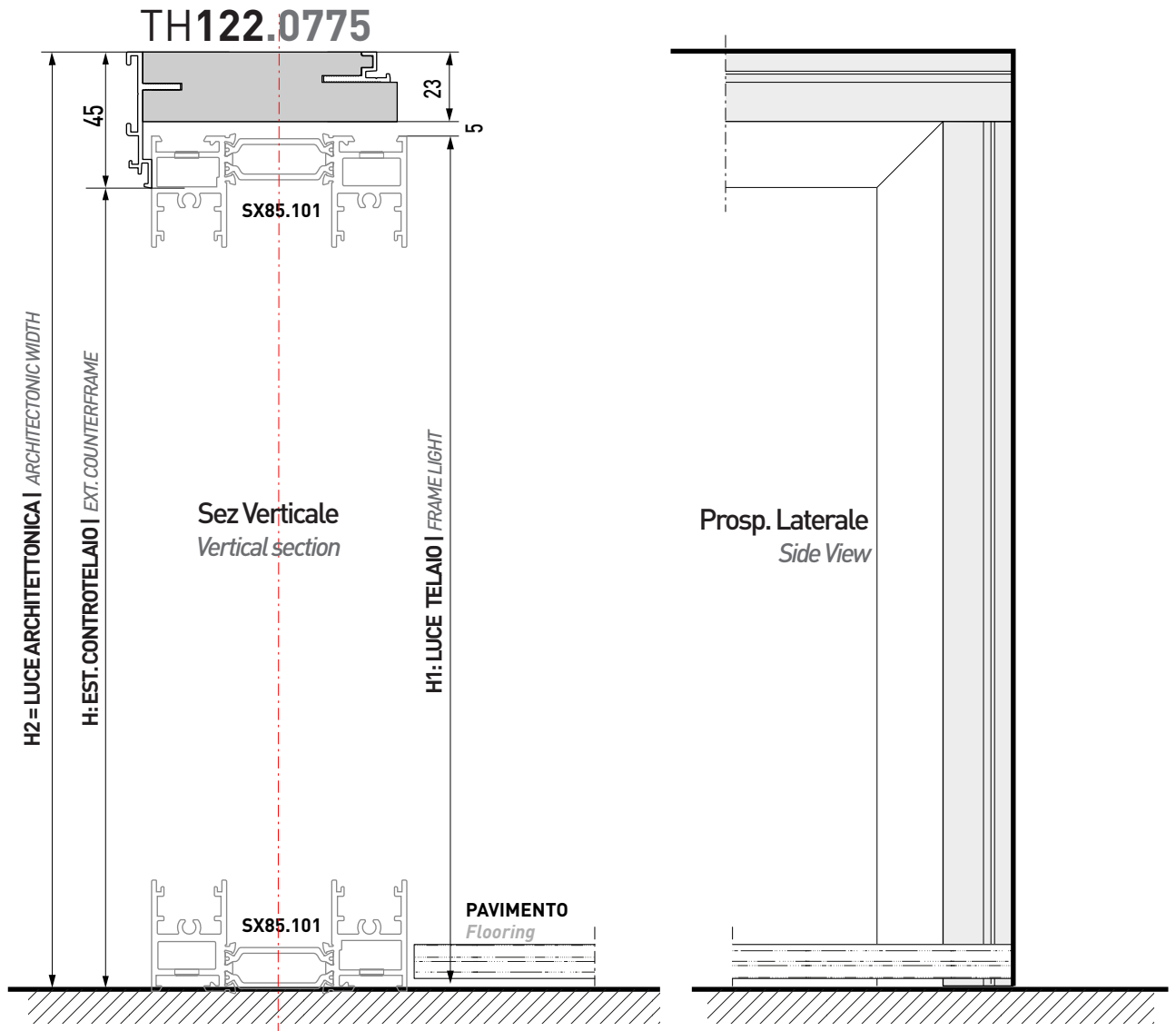
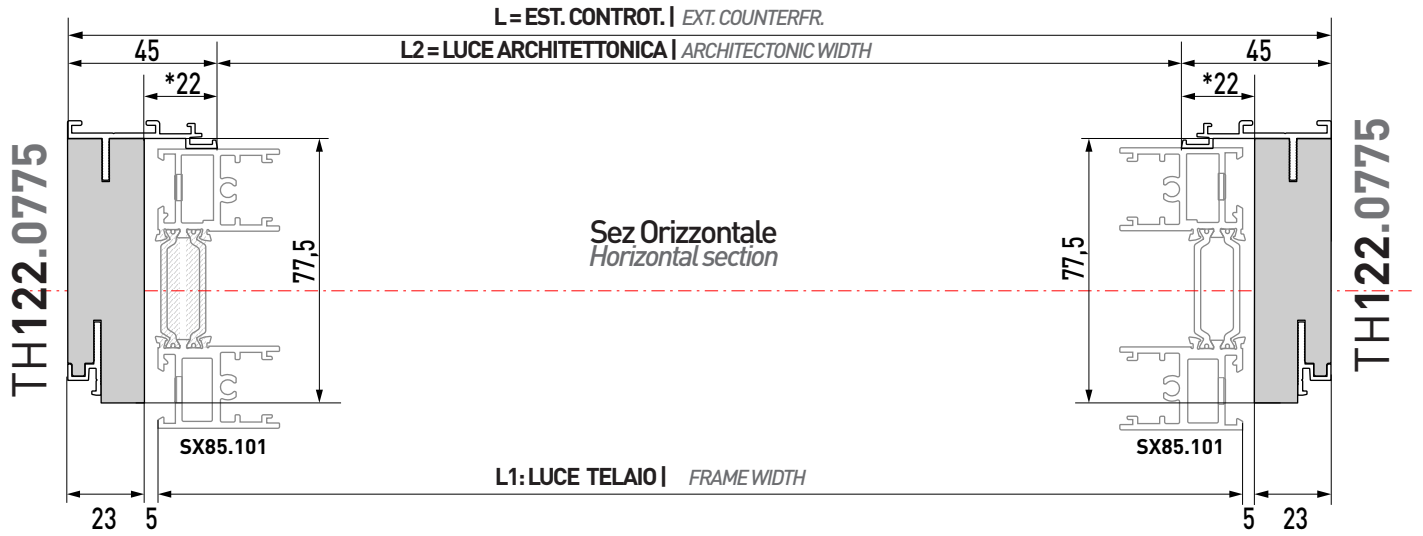

▶ **CONTROTELAIO PERIMETRALE**
▶ **PERIMETRAL COUNTERFRAME**

Soluzione DUE VIE c/Vasca
TWO WAY Solution w/Drainage Channel

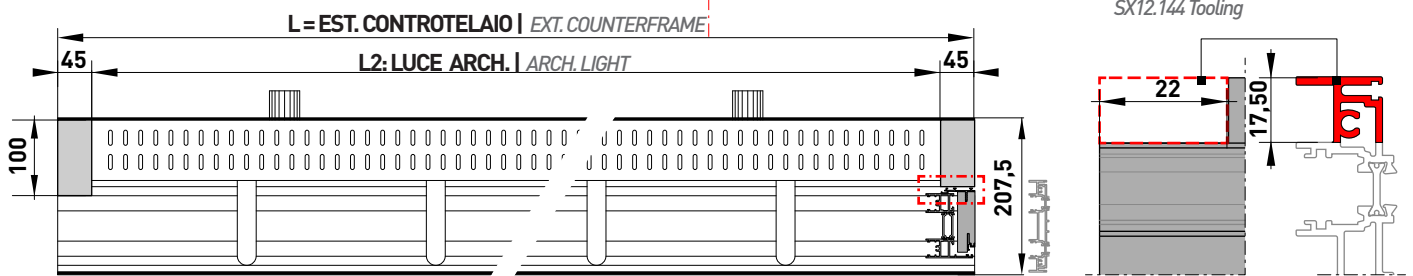
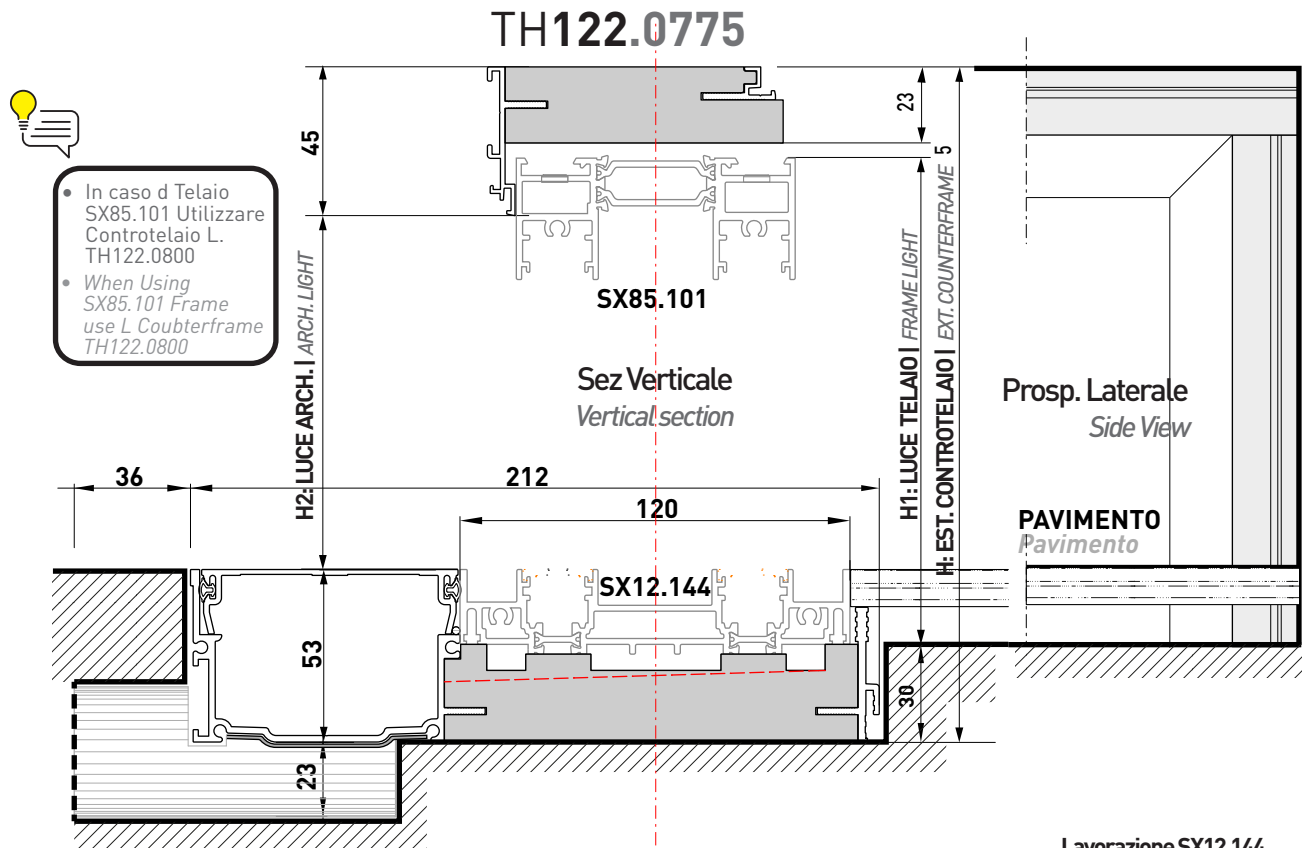
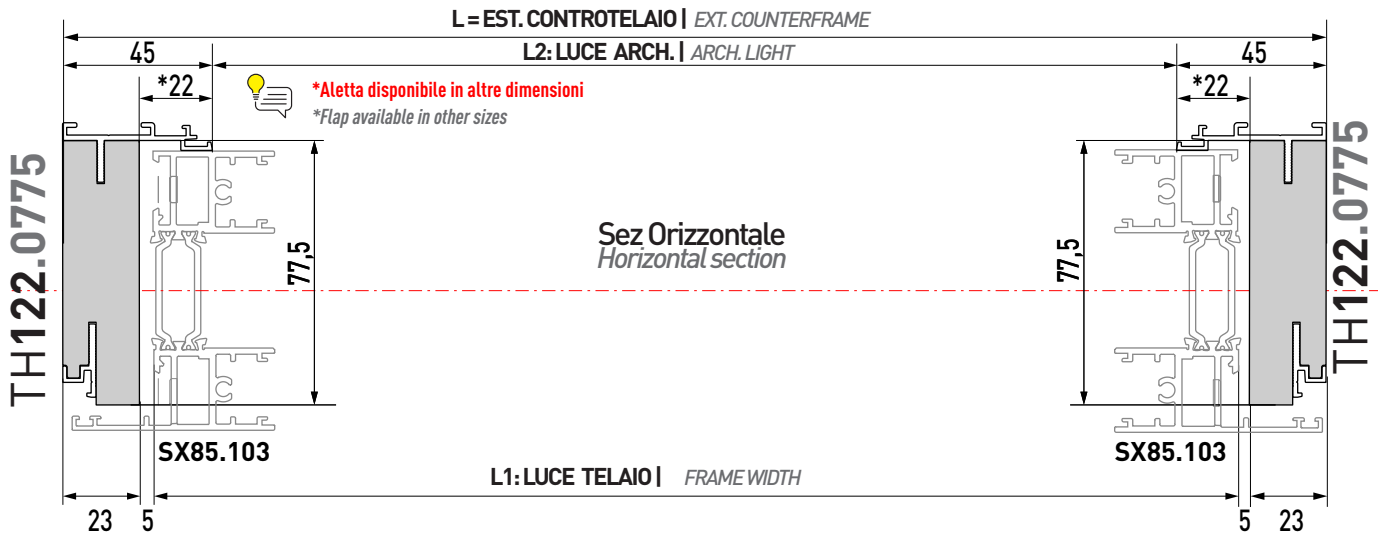

AMXSV120.2

Soglia C/ Vasca Su Misura 2 Binari*

Threshold W/ Custom-Made Drainage Ditch 2 Rails*

*DISPONIBILE IN BARRE da 6500mm art. AMXSG120.2

*AVAILABLE IN BARS L= 6500mm art. AMXSG120.2

AMXSC85.2

Soglia C/ Vasca e Controtelaio a L. Batt. 97.5 2 Binari

Threshold W/ Drainage Ditch and L Counterframe Stop 97.5 2 Rails

▶ **CONTROTELAIO PERIMETRALE**
 ▶ **PERIMETRAL COUNTERFRAME**

Soluzione TRE VIE
THREE WAY Solution

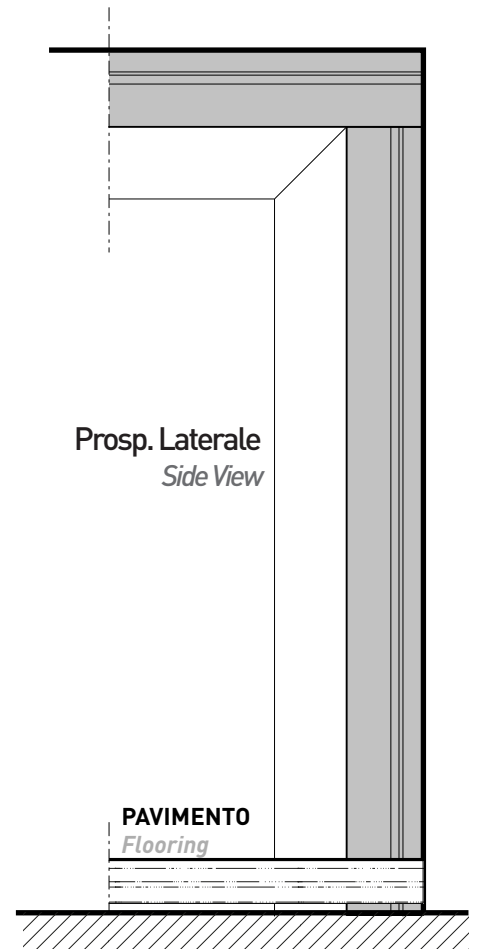
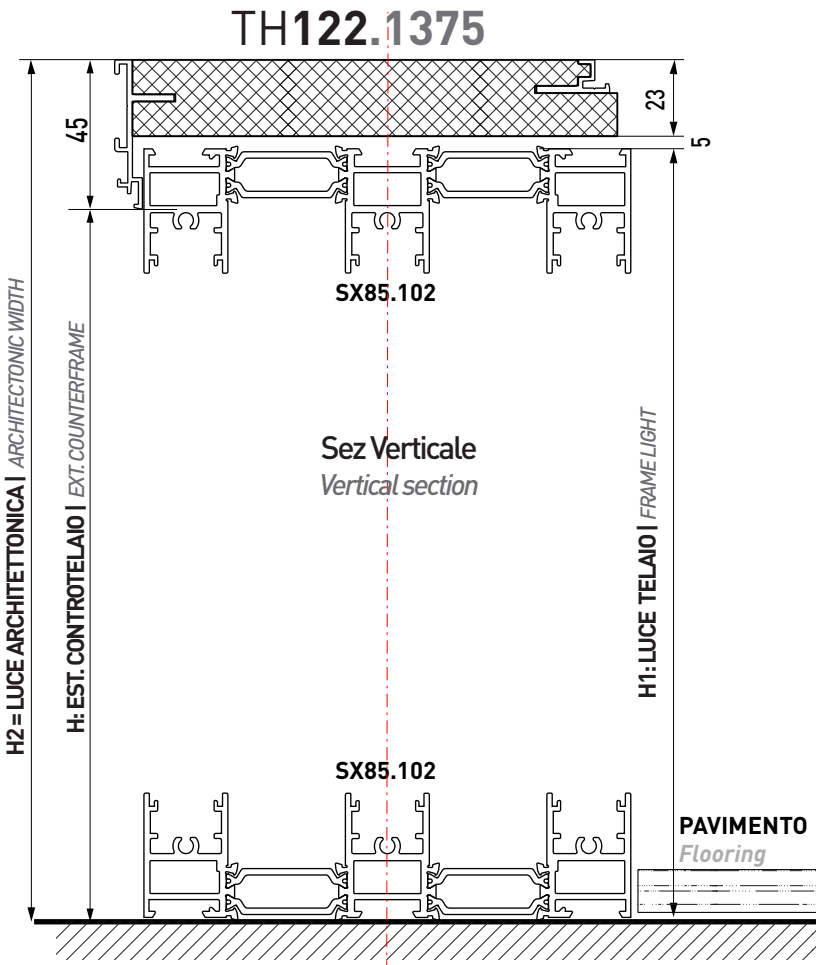
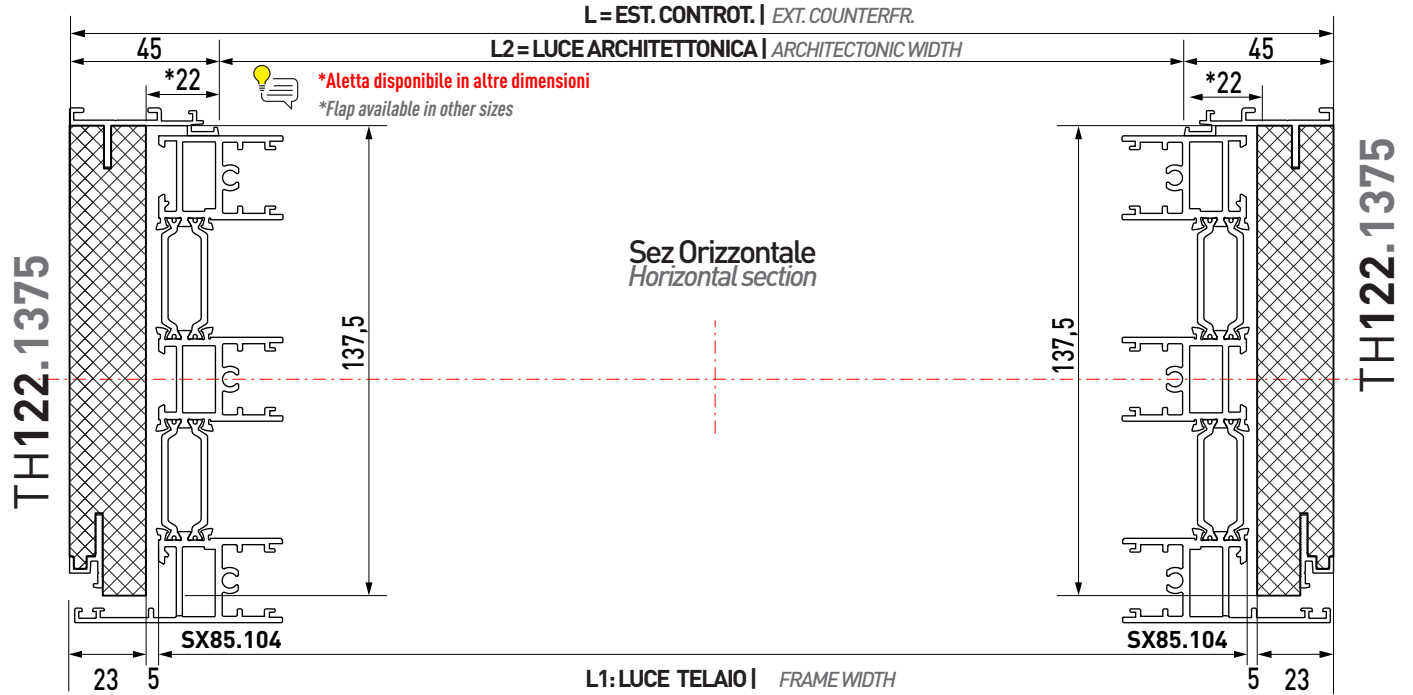

Prosp Laterale
Side View



▶ **CONTROTELAIO PERIMETRALE**
PERIMETRAL COUNTERFRAME

Soluzione TRE VIE c/Vasca
THREE WAY Solution w/Drainage Channel

L = EST. CONTROTELAIO | EXT. COUNTERFRAME

L2: LUCE ARCH. | ARCH. LIGHT

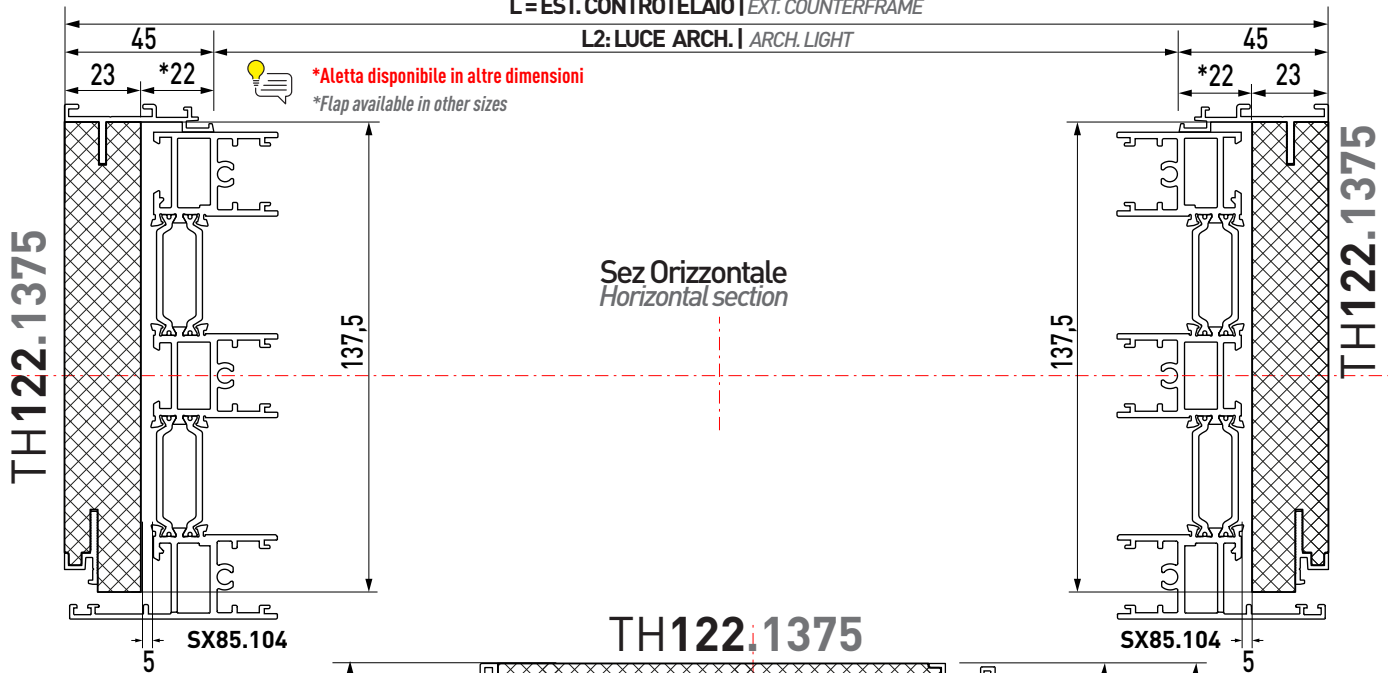

- In caso di Telaio SX85.102 Utilizzare Controtelaio L. TH122.1400
- When Using SX85.102 Frame use L Counterframe TH122.1400

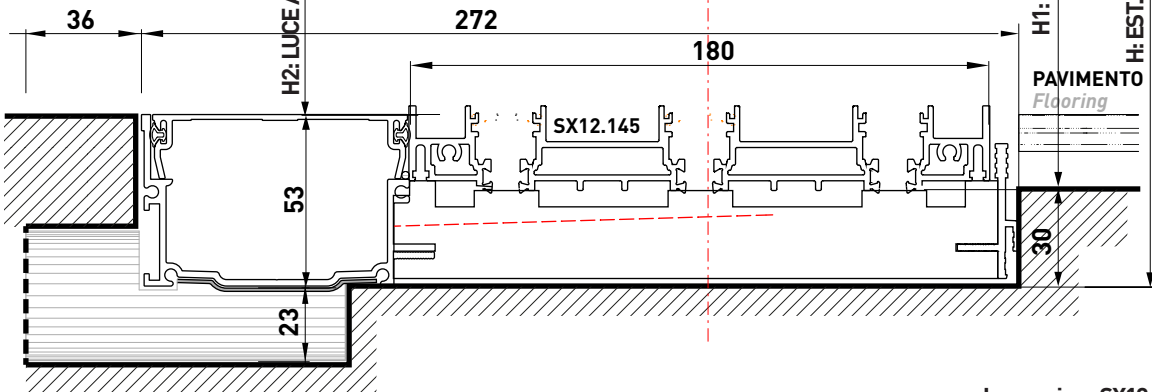
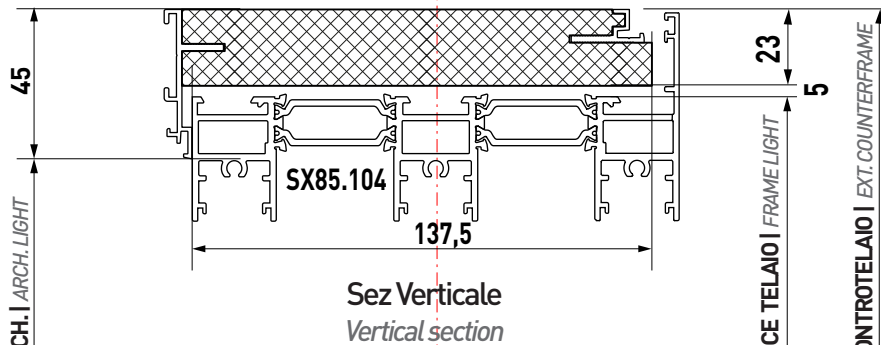

L = EST. CONTROTELAIO | EXT. COUNTERFRAME

L2 = LUCE ARCH. | ARCH. LIGHT

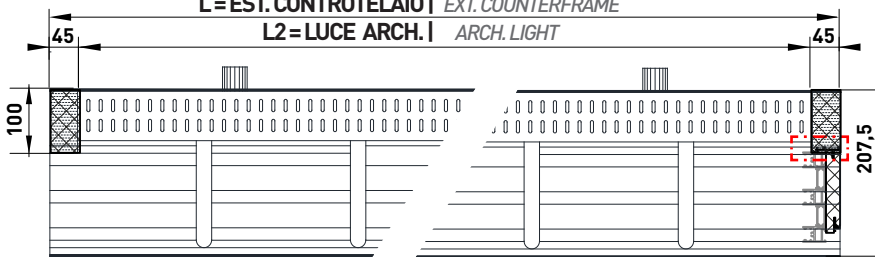

AMXSV120.3

AMXSC85.3

Lavorazione SX12.145
SX12.144 Tooling

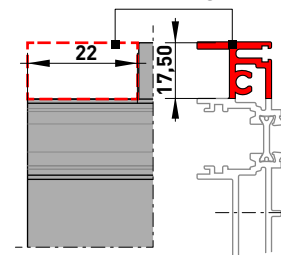

Soglia C/ Vasca Su Misura 3 Binari*

Threshold W/ Custom-Made Drainage Ditch - 3 Rails*

*DISPONIBILE IN BARRE da 6500mm art. AMXSG120.3

*AVAILABLE IN BARS L= 6500mm art. AMXSG120.3

Soglia C/ Vasca e Controtelaio a L. Batt. 137.5 3 Binari

Threshold W/ Drainage Ditch and L Counterframe Stop 97.5 2 Rails



Lavorazioni e Montaggi
Tooling and Assembly

Gruppo **G**

Schemi Lavorazioni
Frese
Attrezzatura

*Tooling Systems
Cutters Equipments
Milling*



■ **FORO+ASOLA SQUADRETTA**
ACX50.SQ

► *HOLE+CORNER JOINT SLOT*
ACX50.SQ

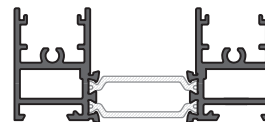
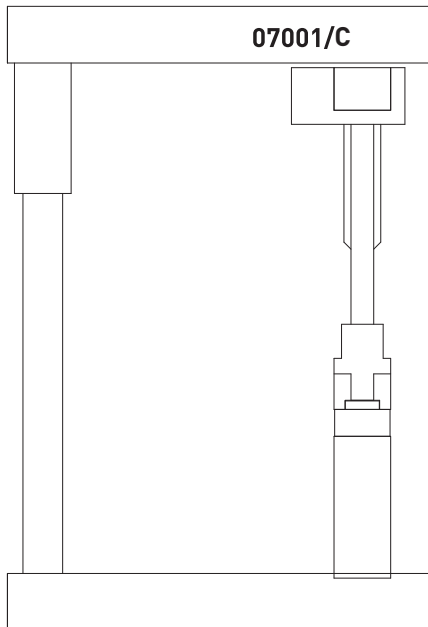

SX85.101

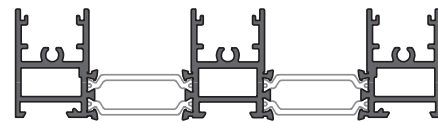

SX85.102

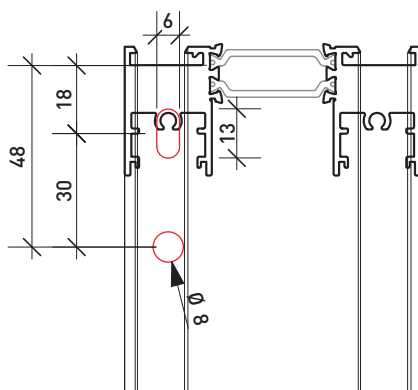

Esclusione Asola 13X6 mm.
Exclusion Slot 13x6 mm.

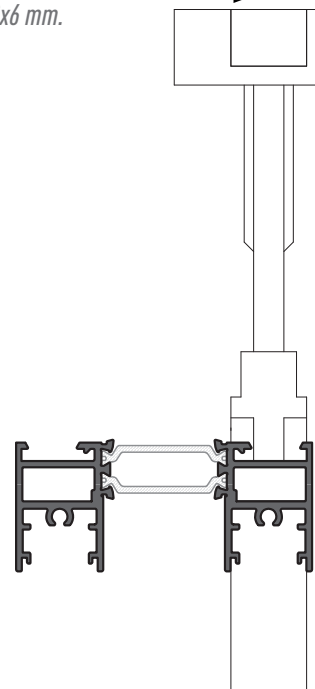

ATTENZIONE | ATTENTION
TUTTE LE BATTUTE SONO | ALL THE STOPS ARE TO BE
DA REGISTRARE | ADJUSTED

MATRICE | MATRIX: **RX0701012**
PUNZONE | DRILLING PUNCH: **08 mm. RX0701014**
PUNZONE | DRILLING PUNCH: **13x06 mm. RX0701015**



■ **FORO+ASOLA SQUADRETTA**
ANTE SX12.203-SX85.201-SX85.204
▶ *HOLE+CORNER JOINT SLOT*
SASHS SX12.203-SX85.201-SX85.204

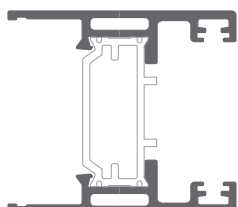

SX12.203

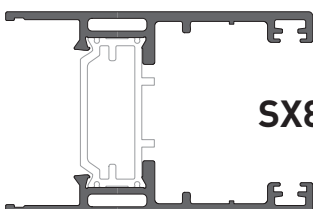

SX85.201

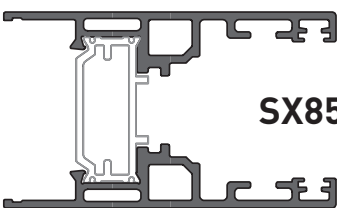

SX85.204

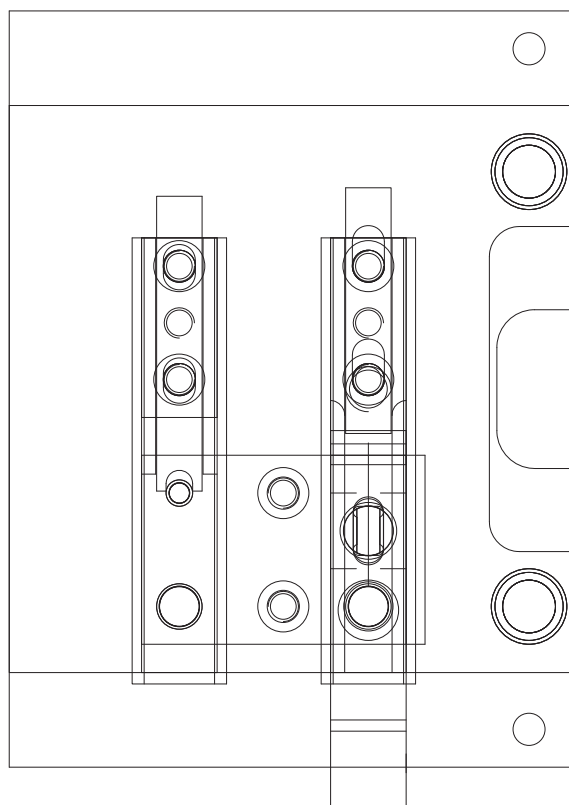
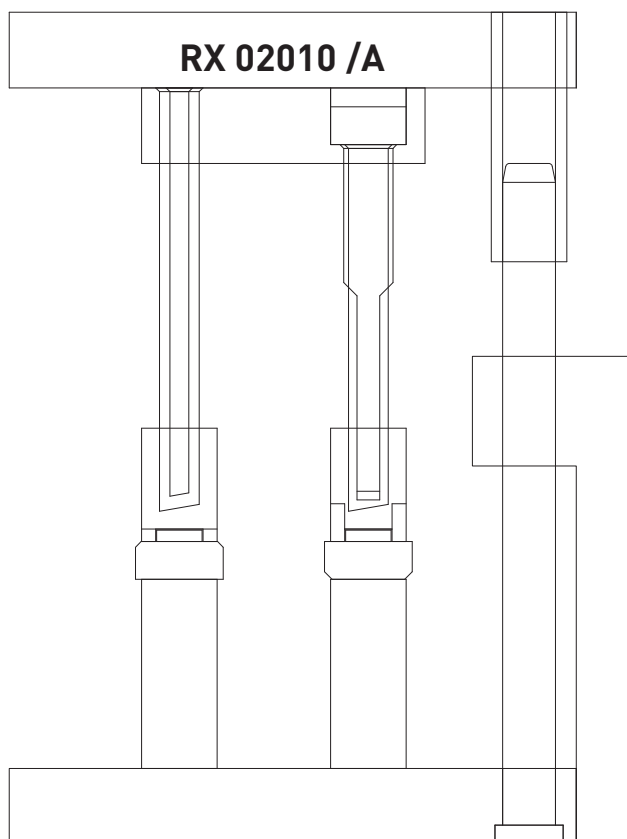
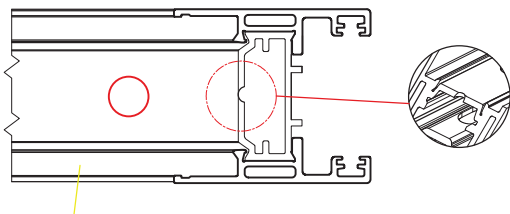
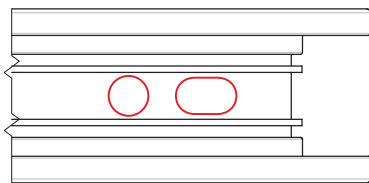

ATTENZIONE | ATTENTION
TUTTE LE BATTUTE SONO DA REGISTRARE | ALL THE STOPS ARE TO BE ADJUSTED



■ **ASOLA RETTANGOLARE SU I PROFILI**

SX12.301 -302...

► **RECTANGULAR LOOP ON PROFILES**
SX12.301 . 302 ...

SX12.302

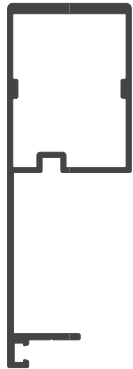

SX12.307



SX12.301



SX12.308

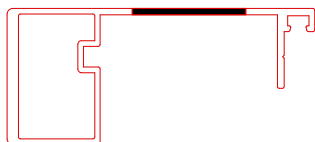

RX 02011A

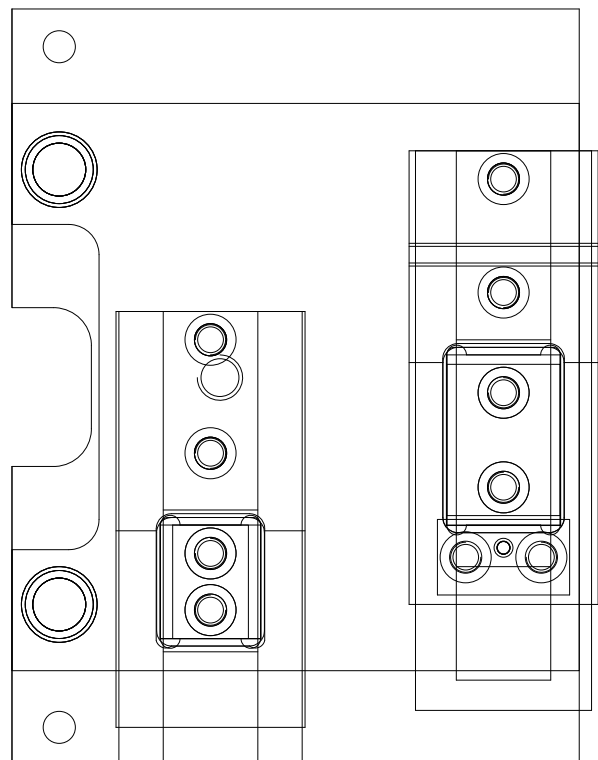
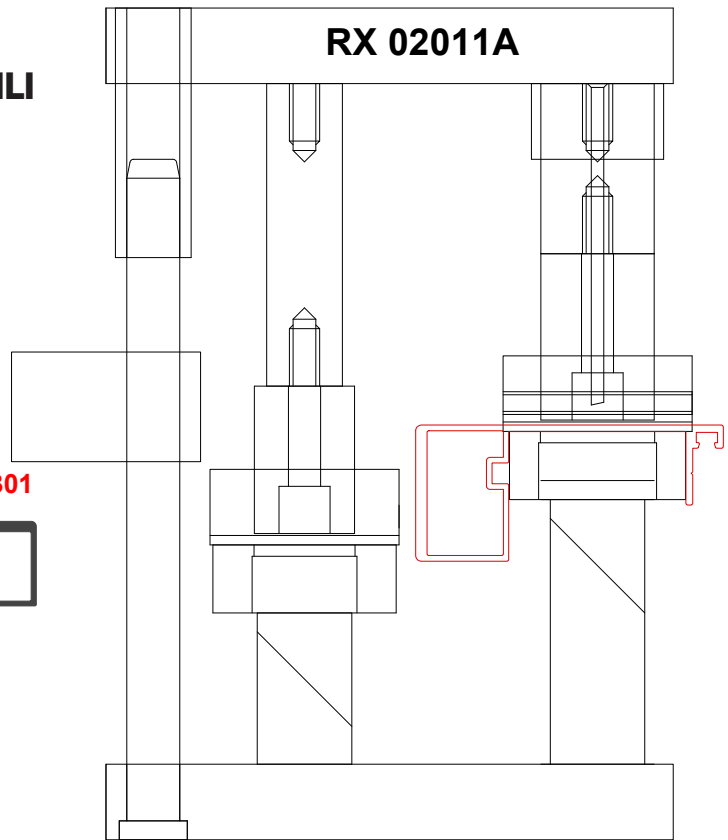



■ **ASPORTAZIONE SU PROFILO SX85.502**

► **REMOVAL ON PROFILE SX85.502**

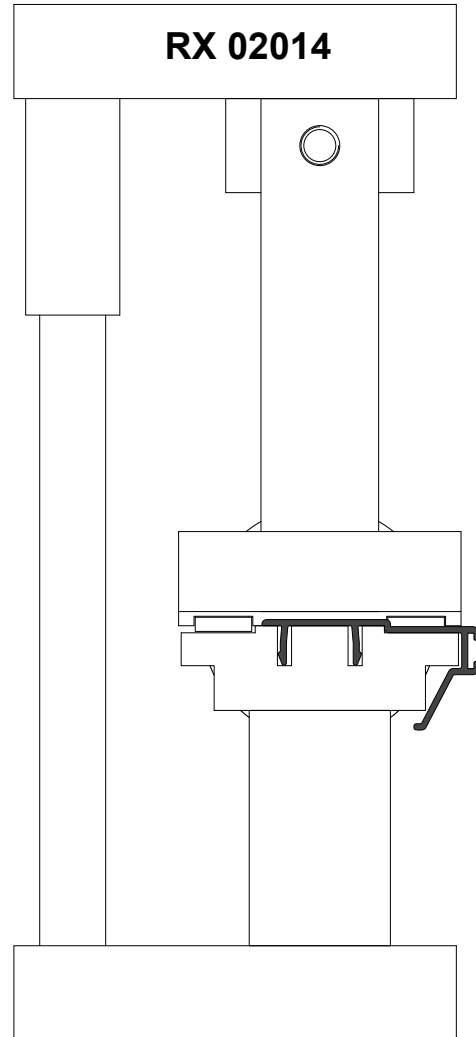
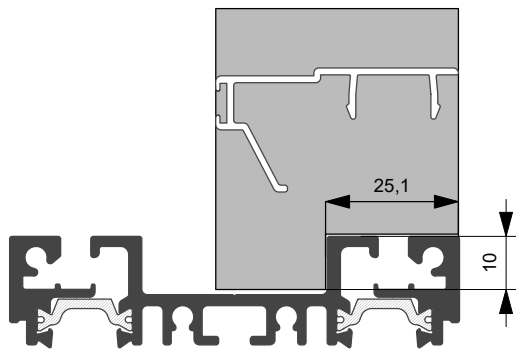
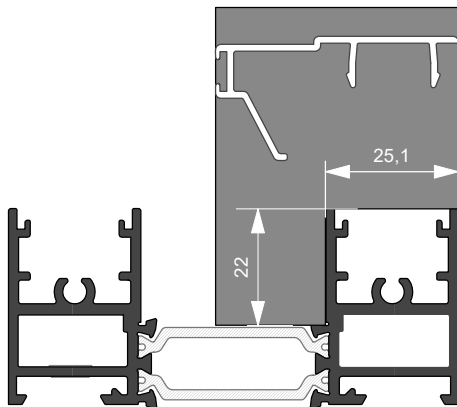
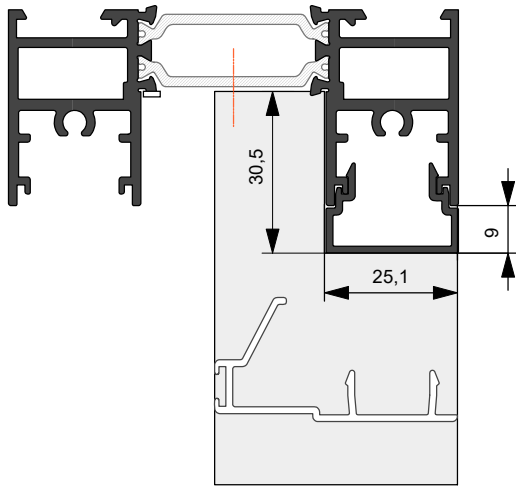

SX85.502

► **INSTALLAZIONE TAPPO SU RIP CENTRALE**
► **PLUG INSTALLATION ON CENTRAL RIP**

ANTA MAGGIORATA
OVERSIZED SASH

ANTA MINIMALE
MINIMAL SASH

TAGLIO PER VERSIONE DESTRA
CUT FOR RIGHT VERSION

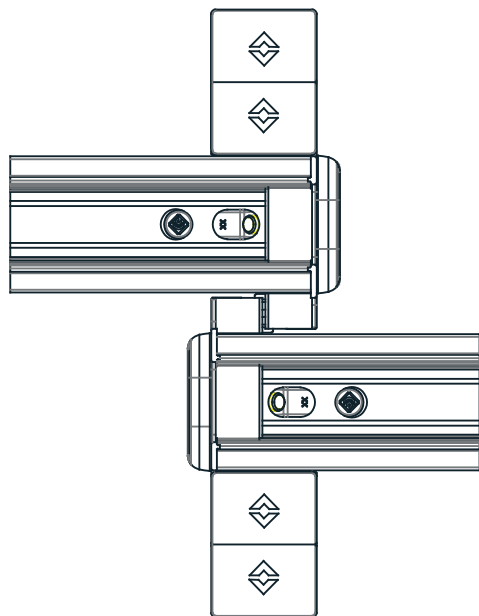

INTERNO
INTERIOR

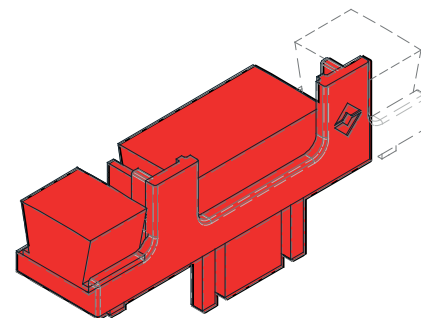
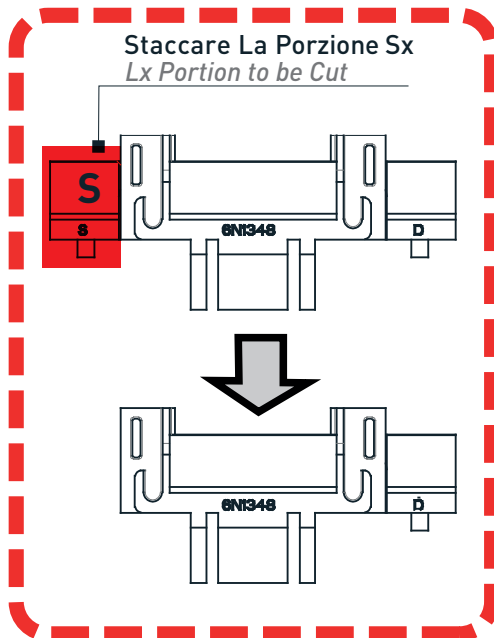

DX RX

*L'accessorio rappresentato è presente nei Kit **ASX.85.K2AM/K3AM/K2AMG**
*The illustrated accessory is included in the ASX.85.K2AM / K3AM / K2AMG kits.

TAGLIO PER VERSIONE SINISTRA
CUT FOR LEFT VERSION

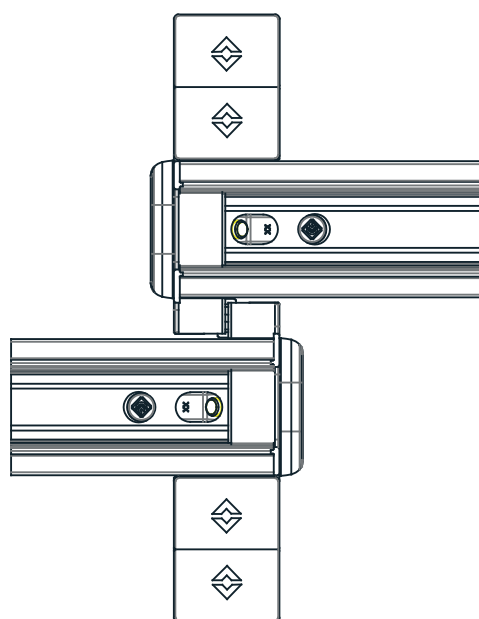

INTERNO
INTERIOR

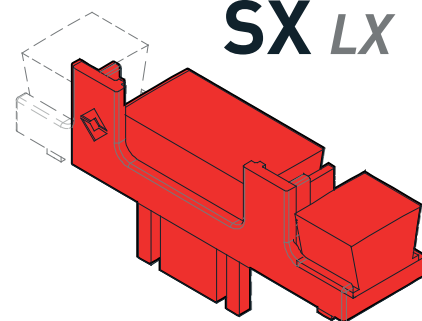
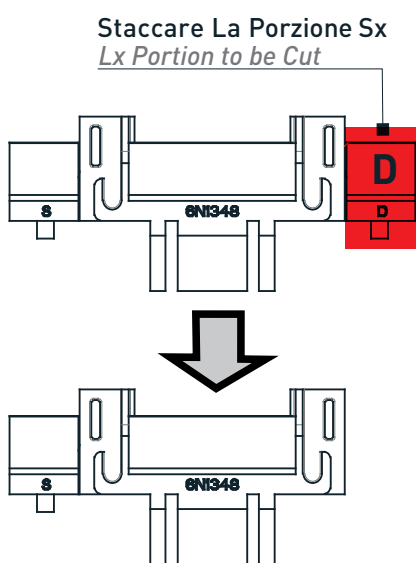

SX LX

*L'accessorio rappresentato è presente nei Kit **ASX.85.K2AM/K3AM/K2AMG**
*The illustrated accessory is included in the ASX.85.K2AM / K3AM / K2AMG kits.



ANTA MAGGIORATA
OVERSIZED SASH

ANTA MINIMALE
MINIMAL SASH

► **LAVORAZIONE MONTANTE CENTRALE**

SX85.301-302-307-308

► **ASSEMBLING ON CENTRAL MULLION SX85.301-302-307-308**

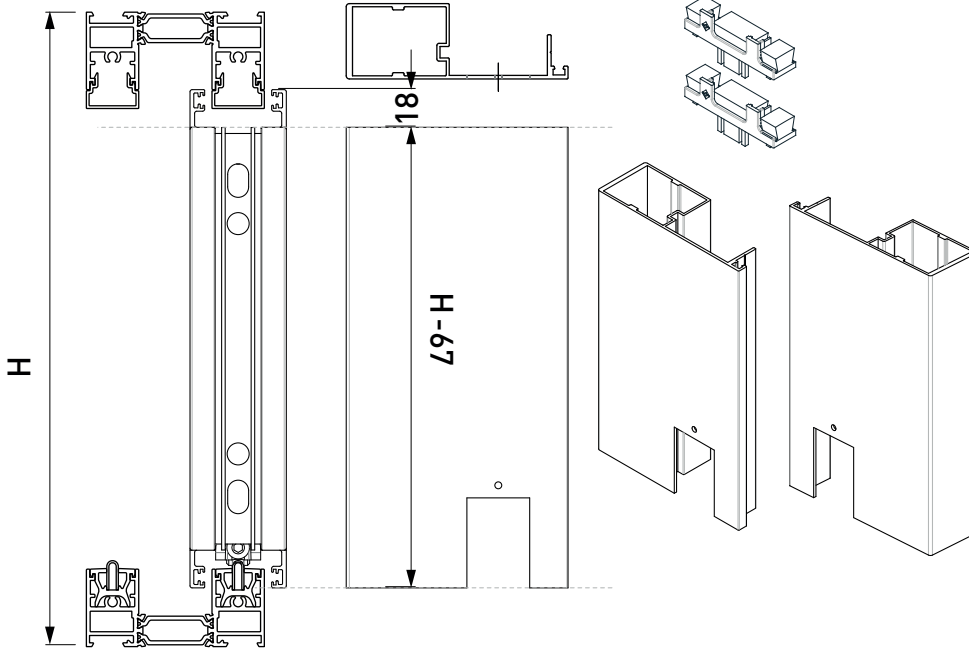

NB.

Lavorazione non prevista dalla pressetta RX02011A
Tooling not to be done by RX02011A

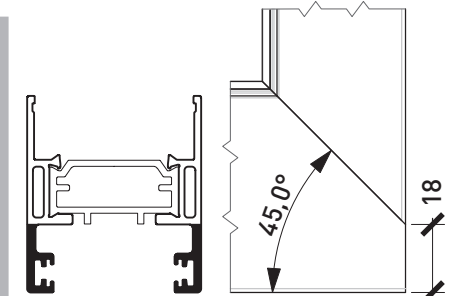

► **ASPORTAZIONE SU SX12.203**

► *REMOVAL OF DRILLS ON SX12.203*

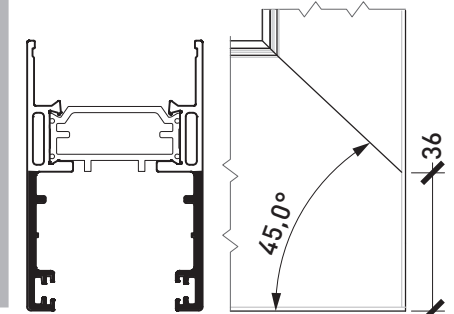

► **ASPORTAZIONE SU SX85.201**

► *REMOVAL OF DRILLS ON SX85.201*

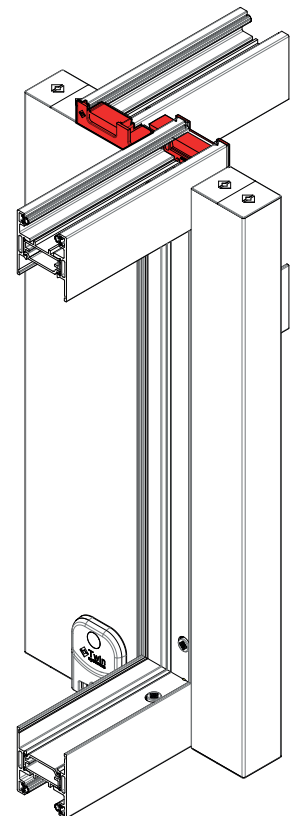
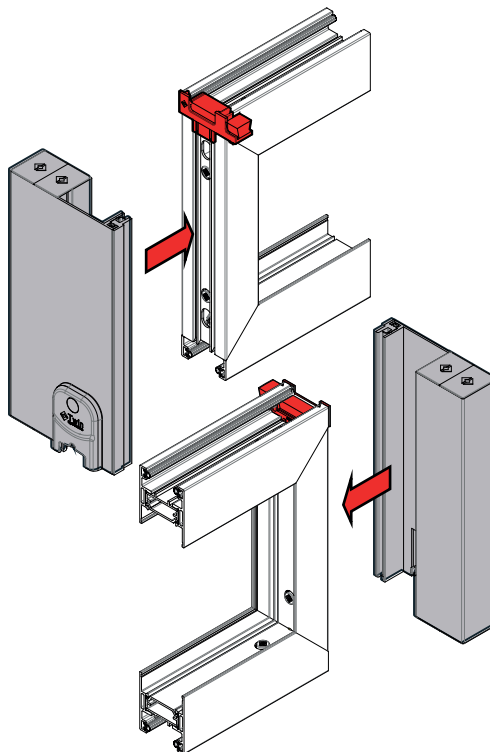
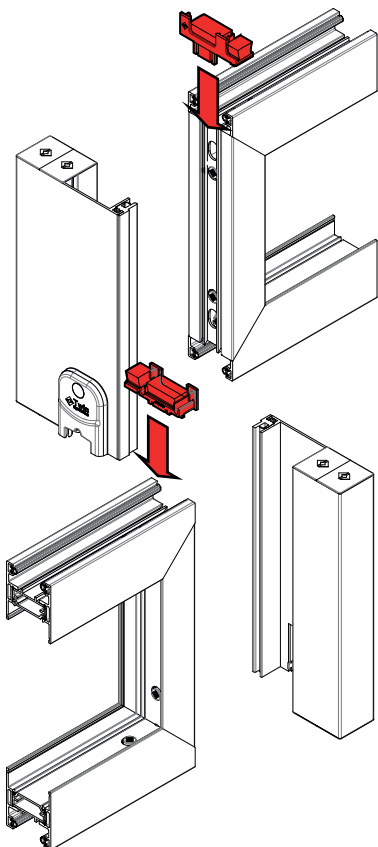

► **LAVORAZIONE CARTER CENTRALE**
CENTRAL CARTER TOOLING

■ **VERSIONE ALZANTE**
LIFTING VERSION

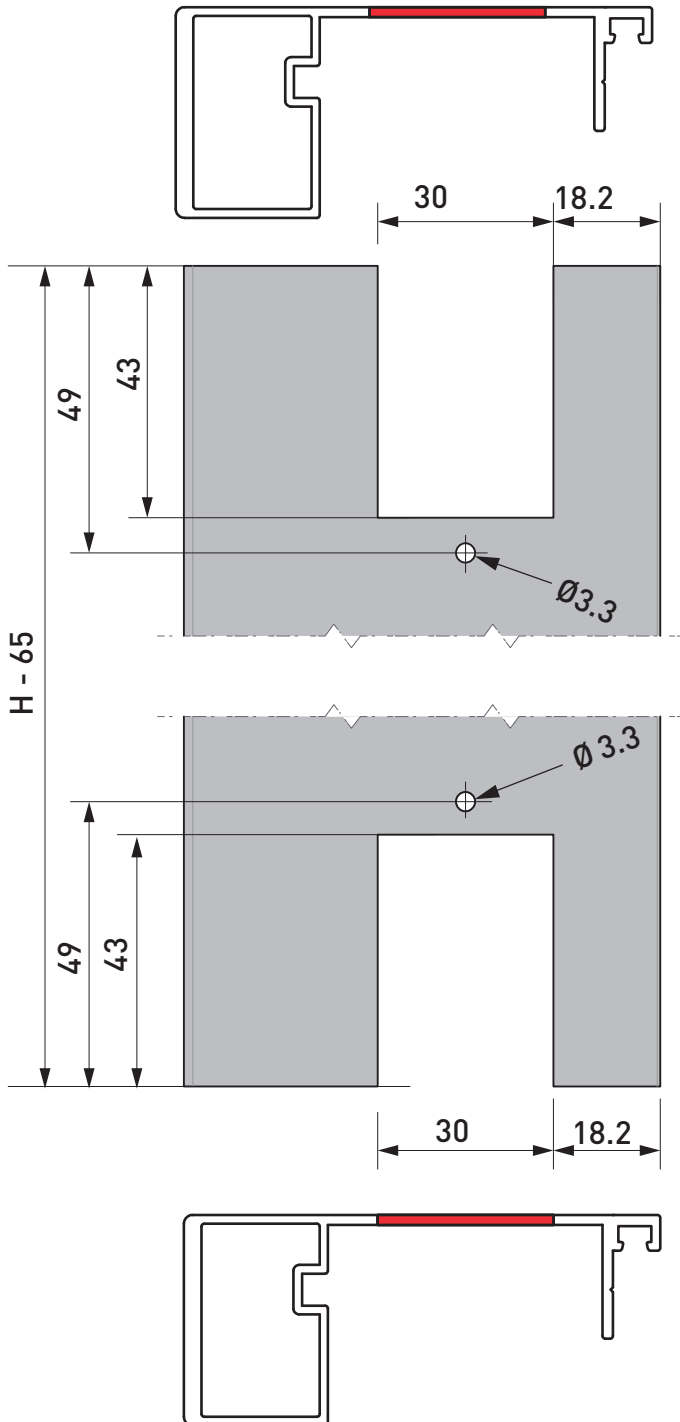

■ **VERSIONE MINIMALE/MAGGIORATA**
MINIMAL/OVERSIZED

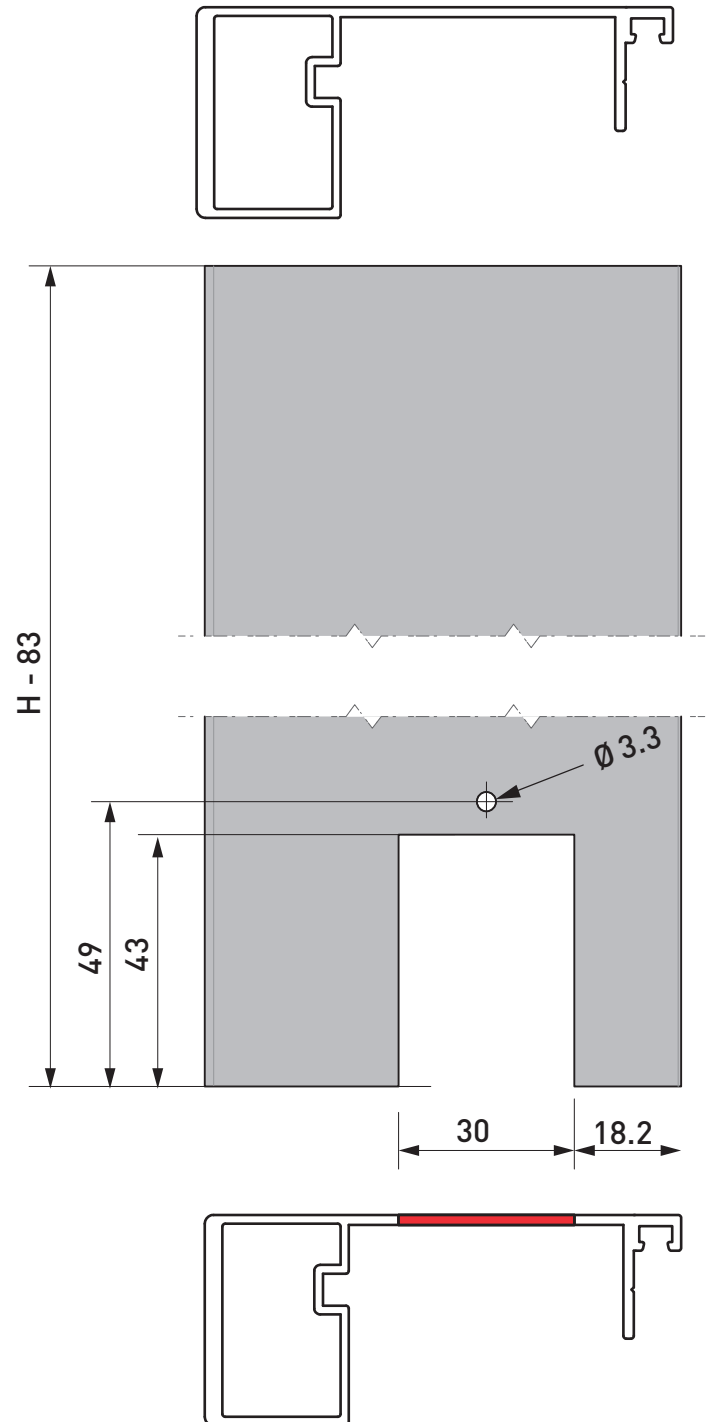

 **Lavorazione eseguibile mediante attrezzatura RX02011A**
Executable processing by equipment RX02011A

► **INSTALLAZIONE TAMPONE CENTRALE SUP**
► *CENTRAL BUFFER INSTALLATION*

VERSIONE MINIMALE
MINIMAL VERSION

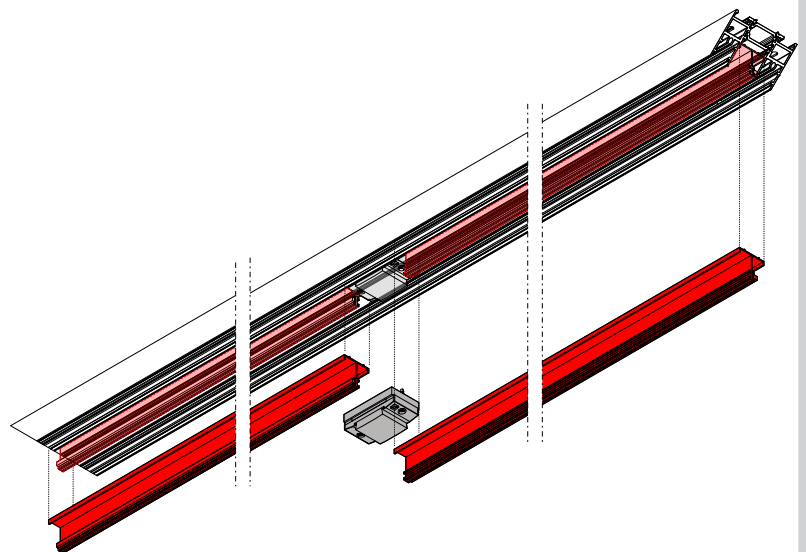
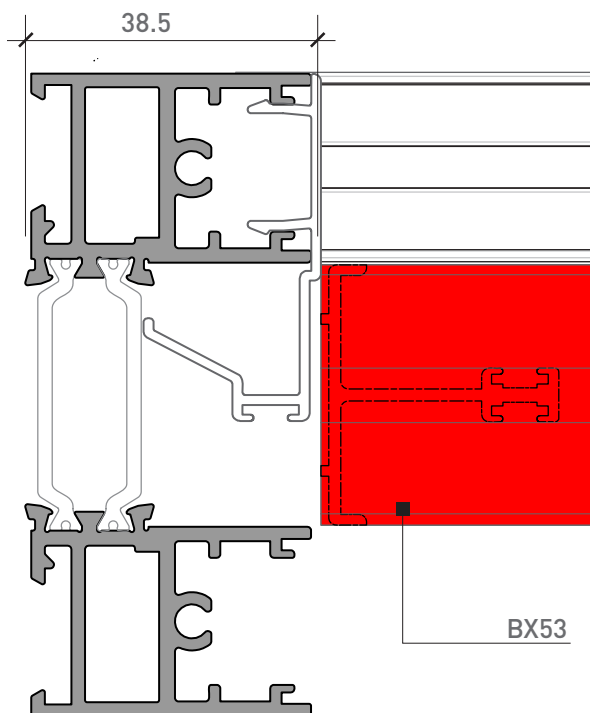
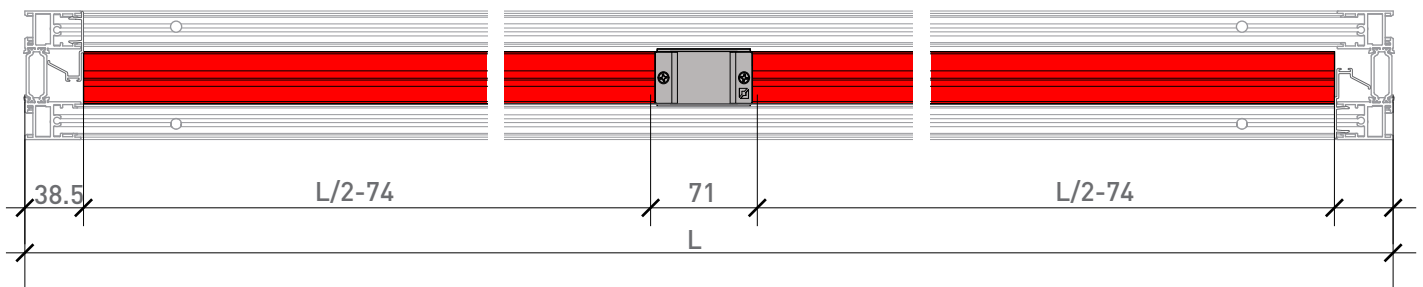
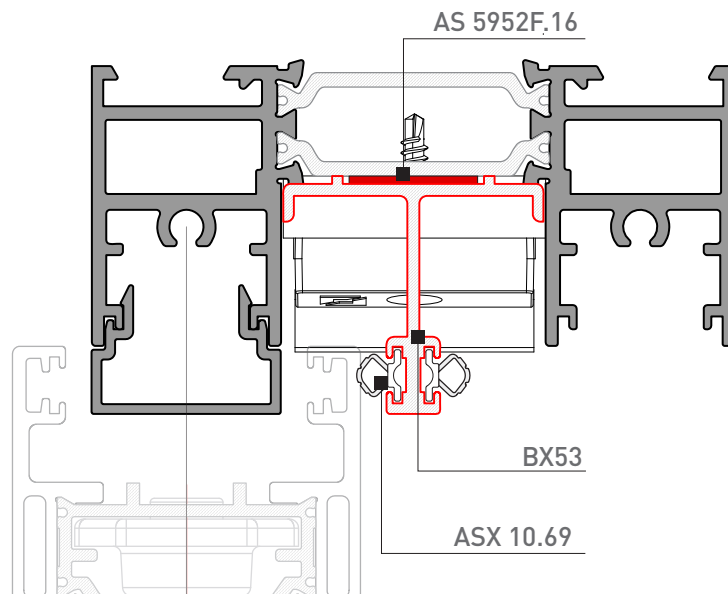



► **INSTALLAZIONE CARRELLI**
► TROLLEY INSTALLATION

VERSIONE MINIMALE
MINIMAL VERSION

ASX85.CAR
ASX85.CAR.N

Asola per inserimento carrelli su ante minimali tipo **SX12.203**
Slot for inserting trolleys on minimal doors type **SX12.203**

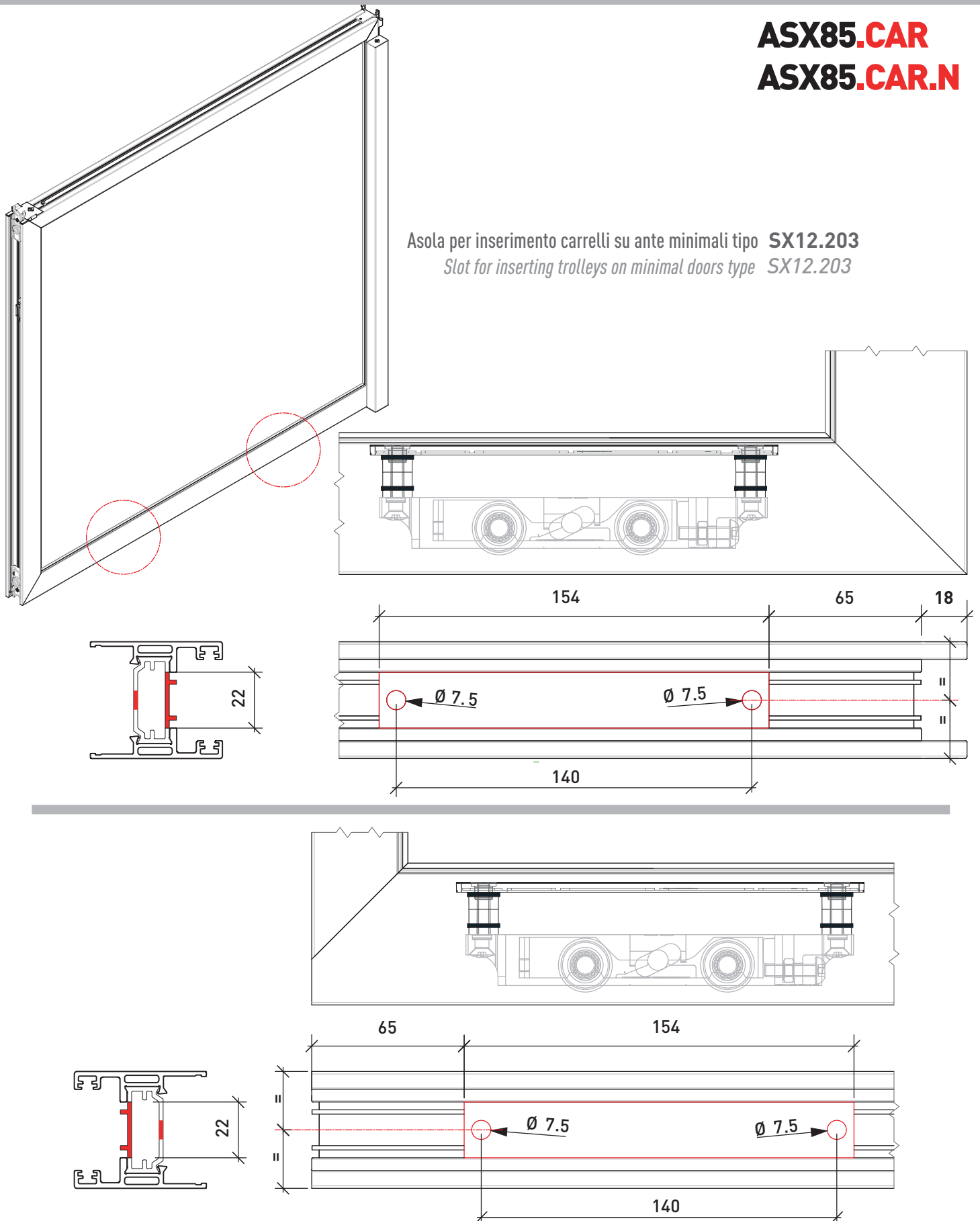

► INSTALLAZIONE CARRELLI
► TROLLEY INSTALLATION

VERSIONE MINIMALE
MINIMAL VERSION

**Tagliare la piastra con 1kit/anta
**Cut the plate for 1kit/sash

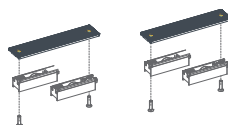
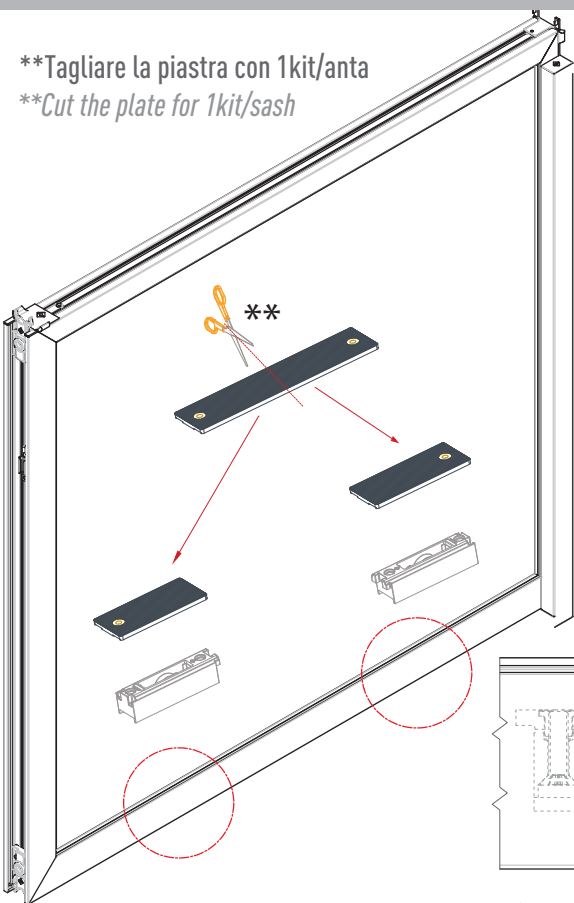

2kit/anta aumenta la portata 180Kg/anta.
2kit/sash increase load 180Kg/sash

ASX85.CAR.NE

1Kit carrelli portata 90Kg/anta
Pair of Trolley 90Kg/sash

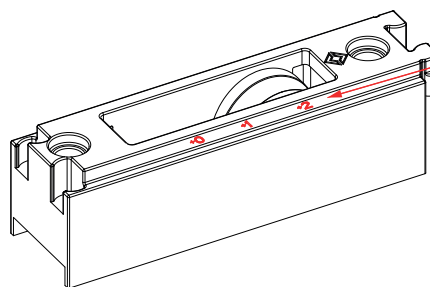

Regolazione ruota +0 / +1 / +2
indicated sopra e sotto
Adjustable roller +0/+1/+2
indicated top and bot part

Asola per inserimento carrelli su ante minimali tipo SX12.203
Slot for inserting trolleys on minimal doors type SX12.203

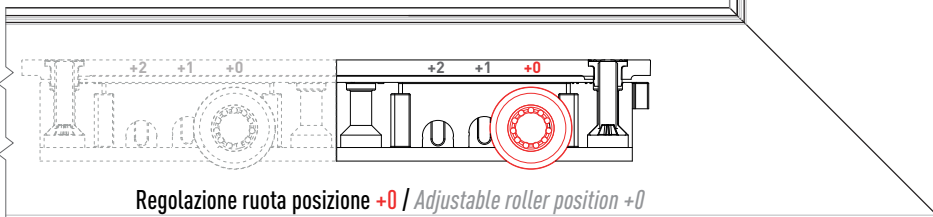

Regolazione ruota posizione +0 / Adjustable roller position +0

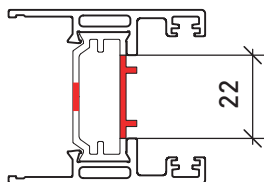

Regolazione ruota posizione +2
Adjustable roller position +2

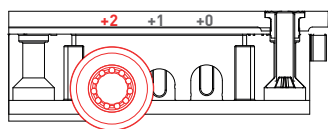

*Con soluzione 2kit/anta fare lavorazione doppia
*with 2kit/sash make double tooling

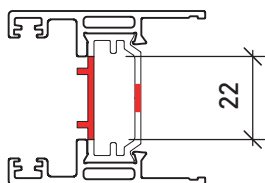

Regolazione ruota posizione +1 / Adjustable roller position +1

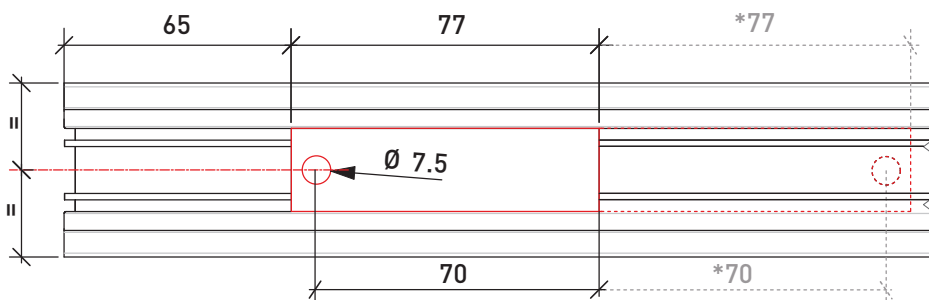

► **INSTALLAZIONE CARRELLI: LAVORAZIONI**

► TROLLEY INSTALLATION: TOOLING

VERSIONE MAGGIORATA
OVERSIZED VERSION

ASX85.CARMAG

Asola per inserimento carrelli su ante maggiorate tipo **SX12.206**
Slot for inserting trolleys on oversized doors type **SX12.206**

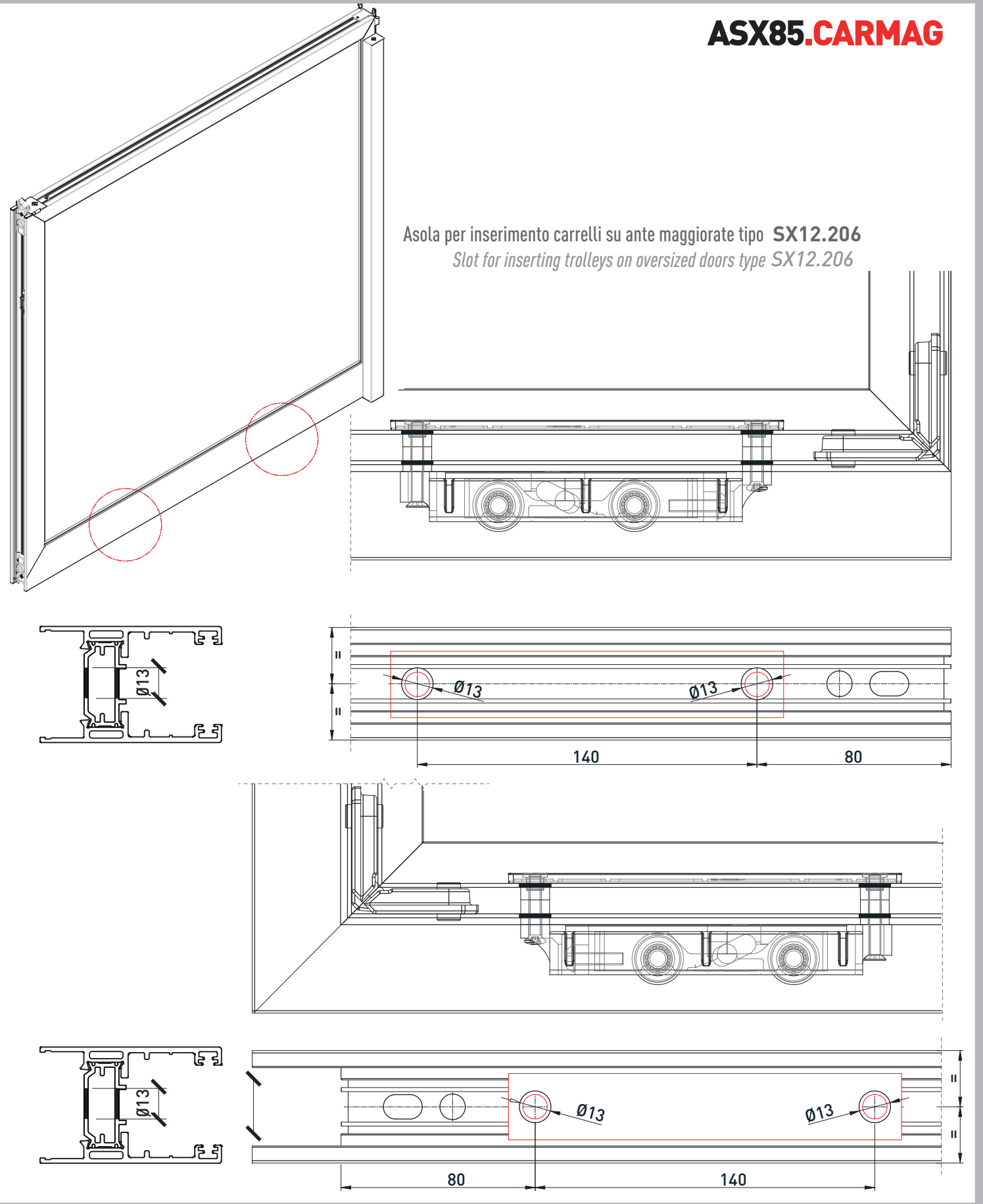

■ **DETTAGLI DI LAVORAZIONE**

► **PROCESSING DETAILS**

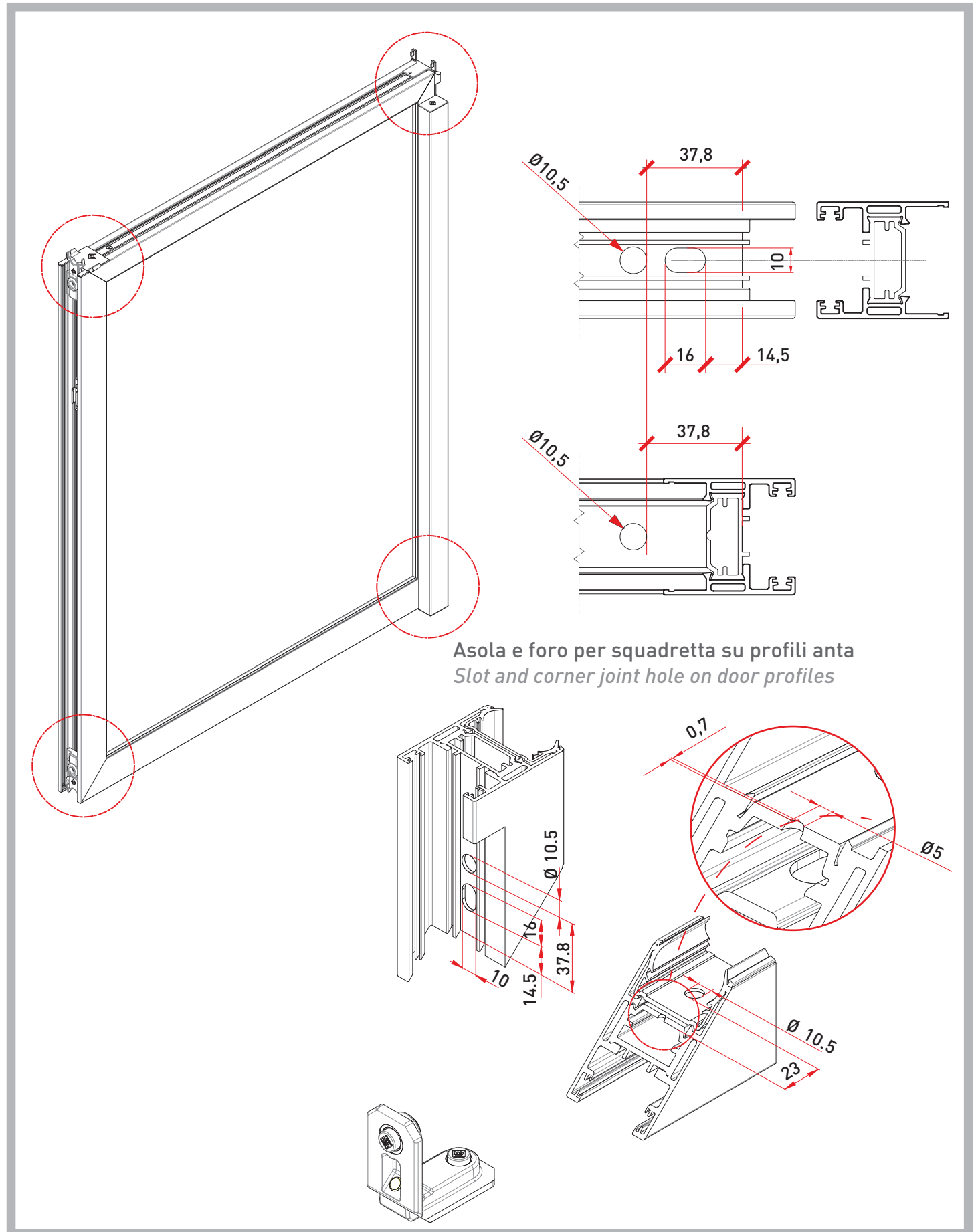

Asola e foro per squadretta su profili anta
Slot and corner joint hole on door profiles



■ **DETTAGLI DI LAVORAZIONE**
► **PROCESSING DETAILS**

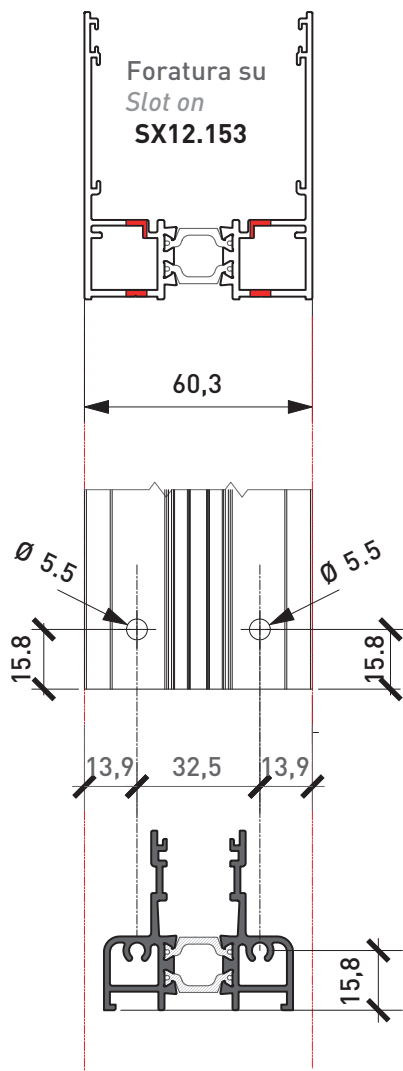
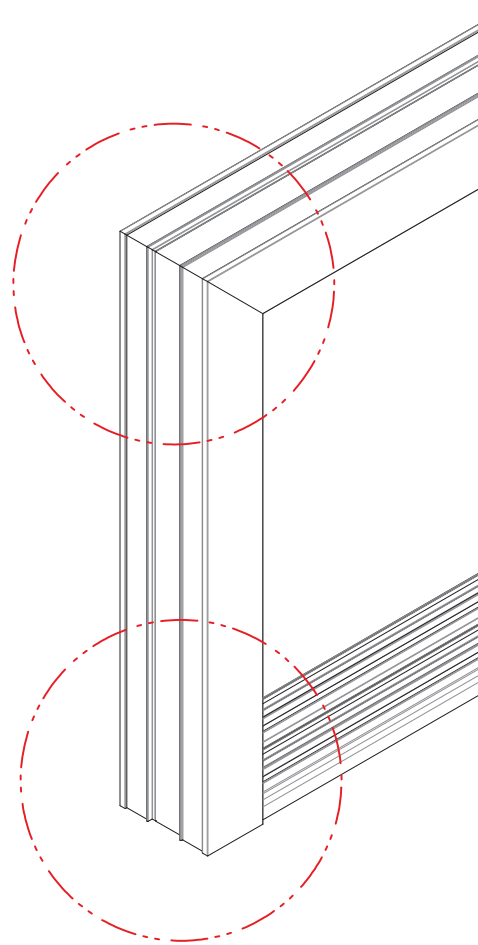

Asola e foro per squadretta (AWX 16.SQ)
su profilo **SX12.153**
Slot and corner joint hole on profiles SX12.153

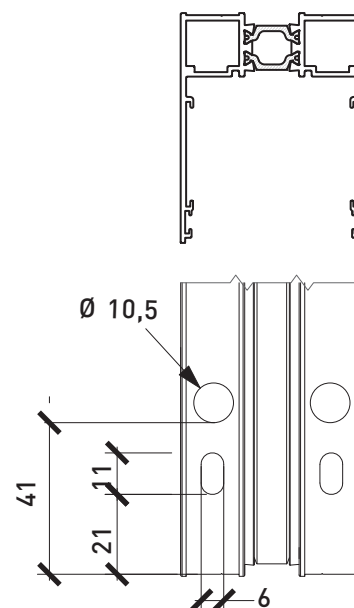

■ **DETTAGLI DI LAVORAZIONE**
► *PROCESSING DETAILS*

ASX.12.MTMDX / MTMSX

Kit maniglia singola movimentazione DX / SX
Single handle kit for RH / LT movement

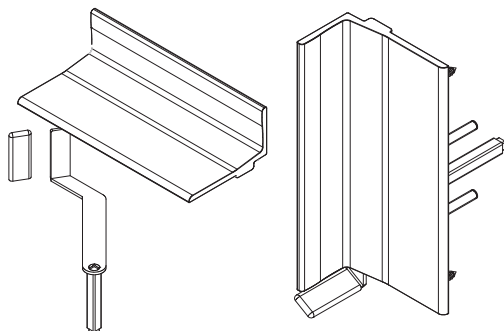

Lavorazione per passaggio perno
Machining by pin passage

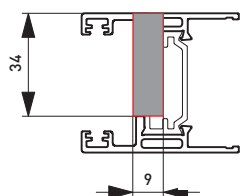

Taglio perno
Pin cut

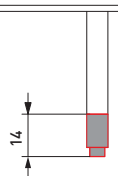

ASX.12.MTF

Maniglia traino FISSA
FIXED train handle

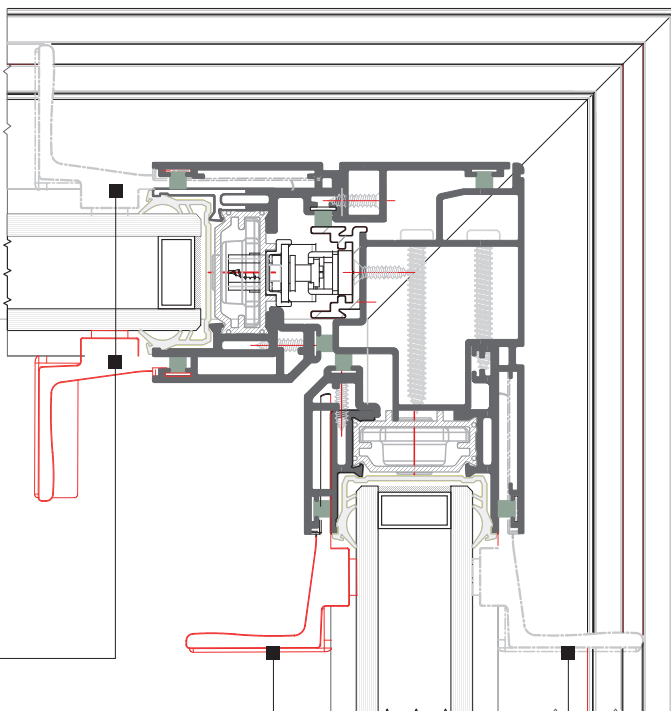
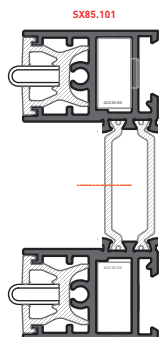
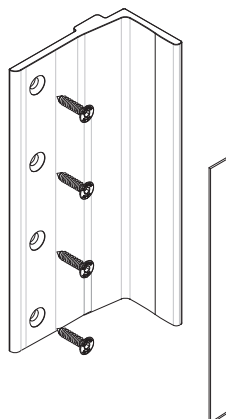

ASX.12.MTMDX / MTMSX

Esterno Opzionale
External Optional

ASX.12.MTF

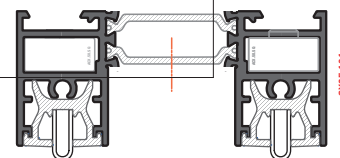

■ **MONTAGGIO 4 ANTA**
► 4th sash assembling

VERSIONE MINIMALE
MINIMAL VERSION

Esplso del particolare di assemblaggio

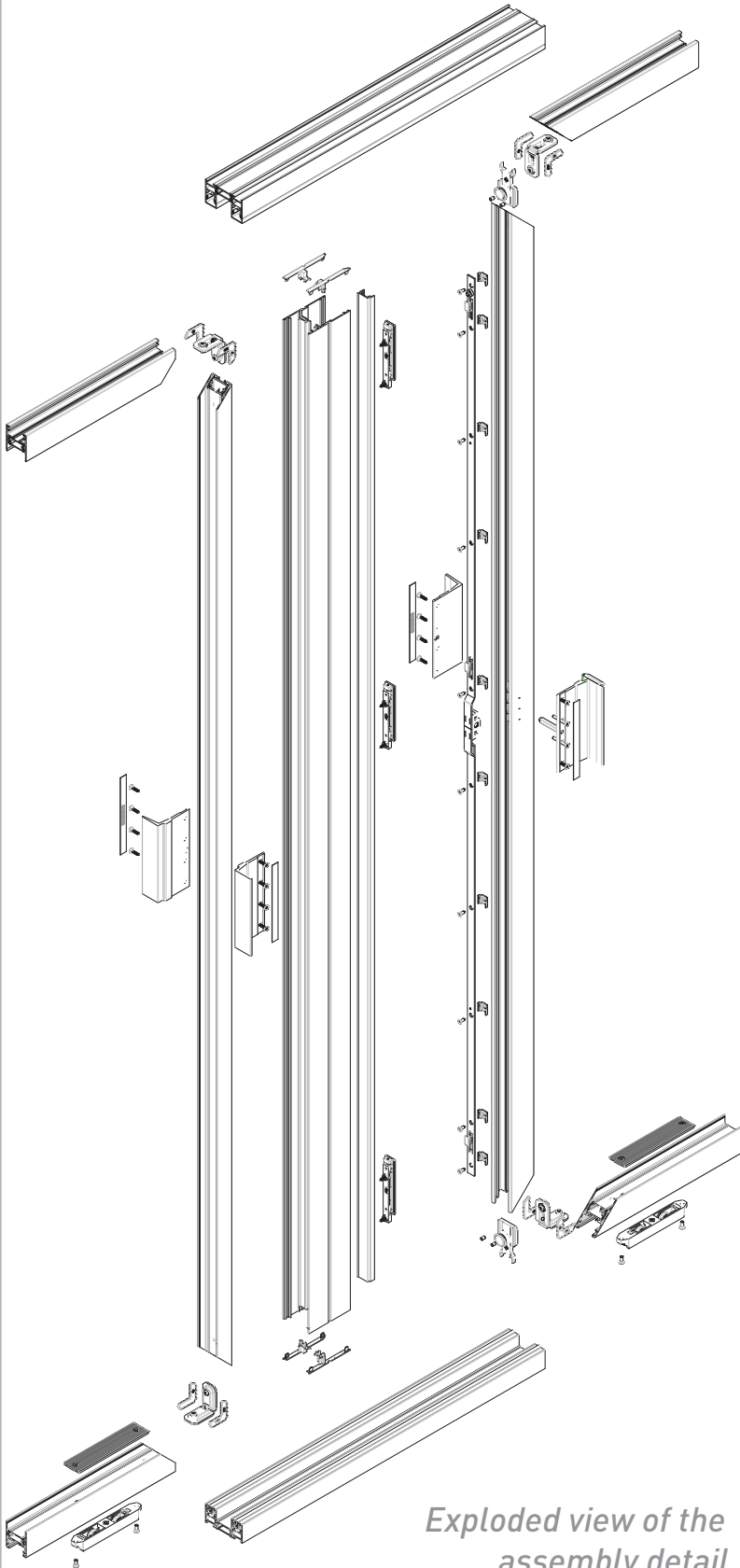

*Exploded view of the
assembly detail*

Particolare di assemblaggio
angolo ante

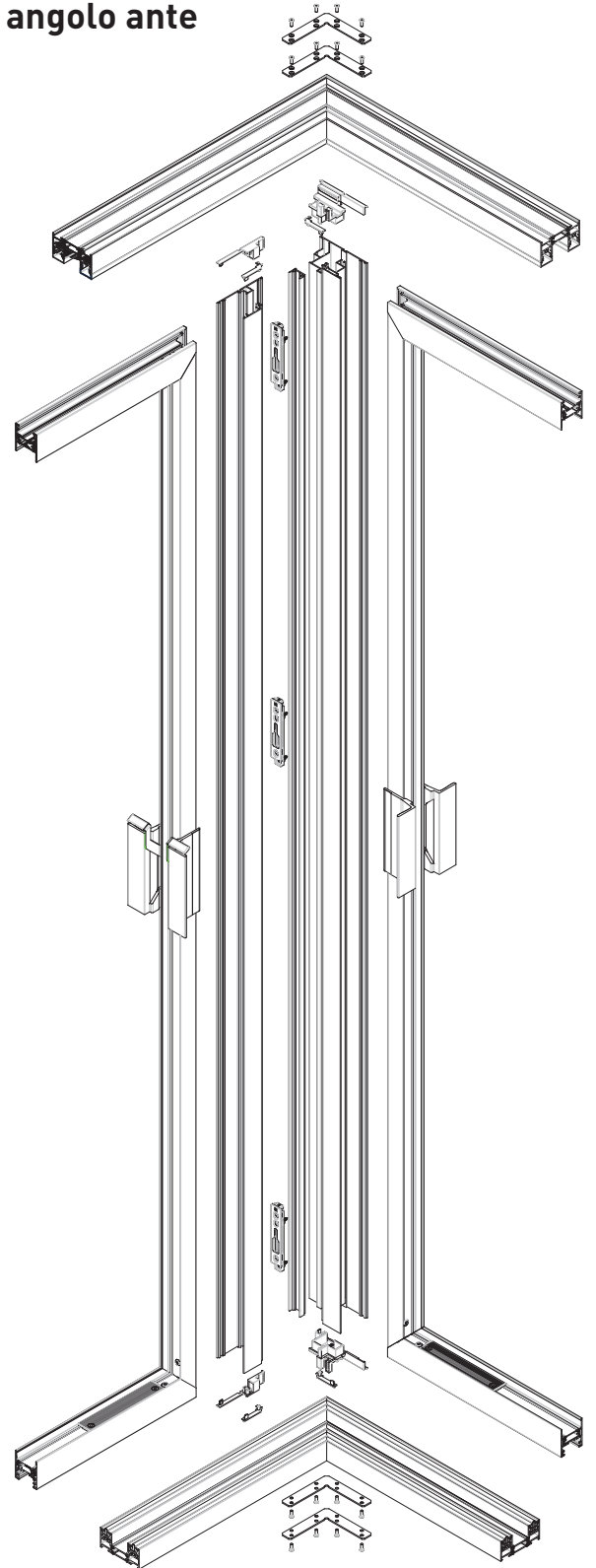

Detail of corner assembly doors



■ **MONTAGGIO 4 ANTA**

► 4Th Sash Assembling

ANTA MAGGIORATA
OVERSIZED SASH

Esplso del particolare di assemblaggio

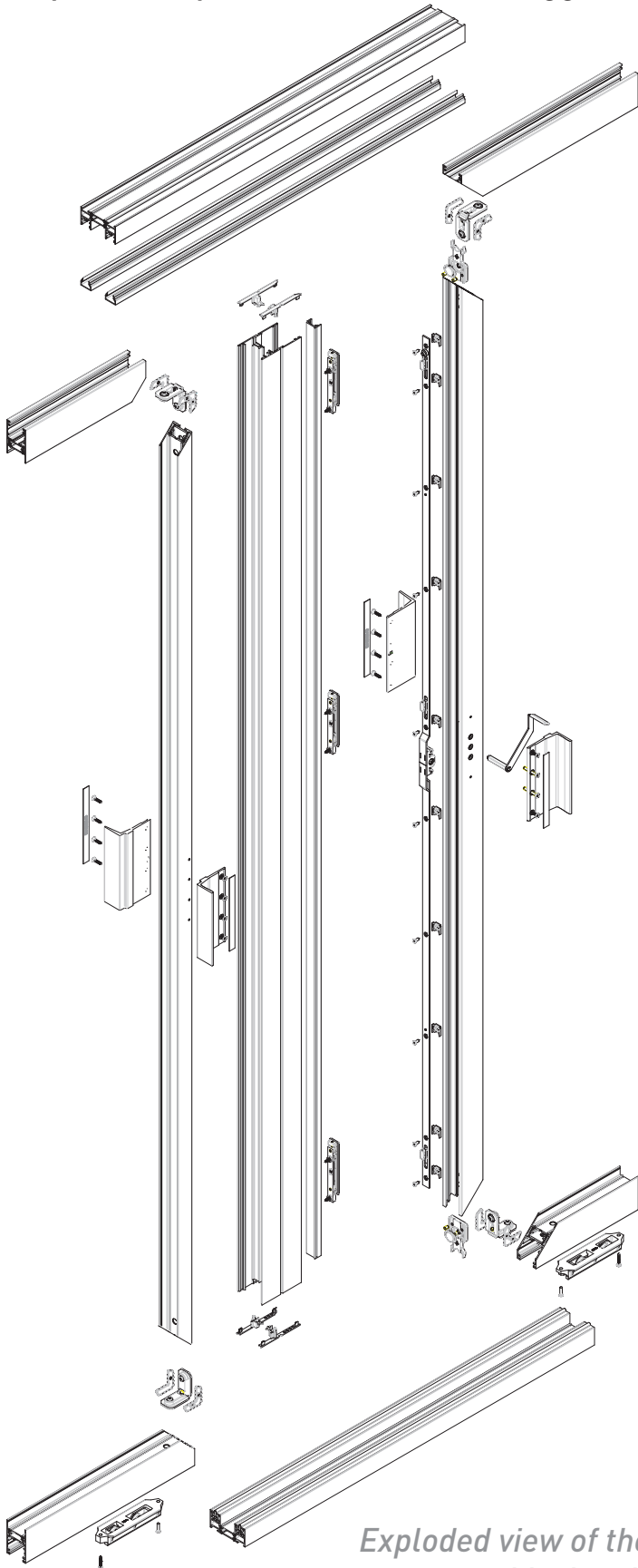

Exploded view of the assembly detail

Particolare di assemblaggio angolo ante

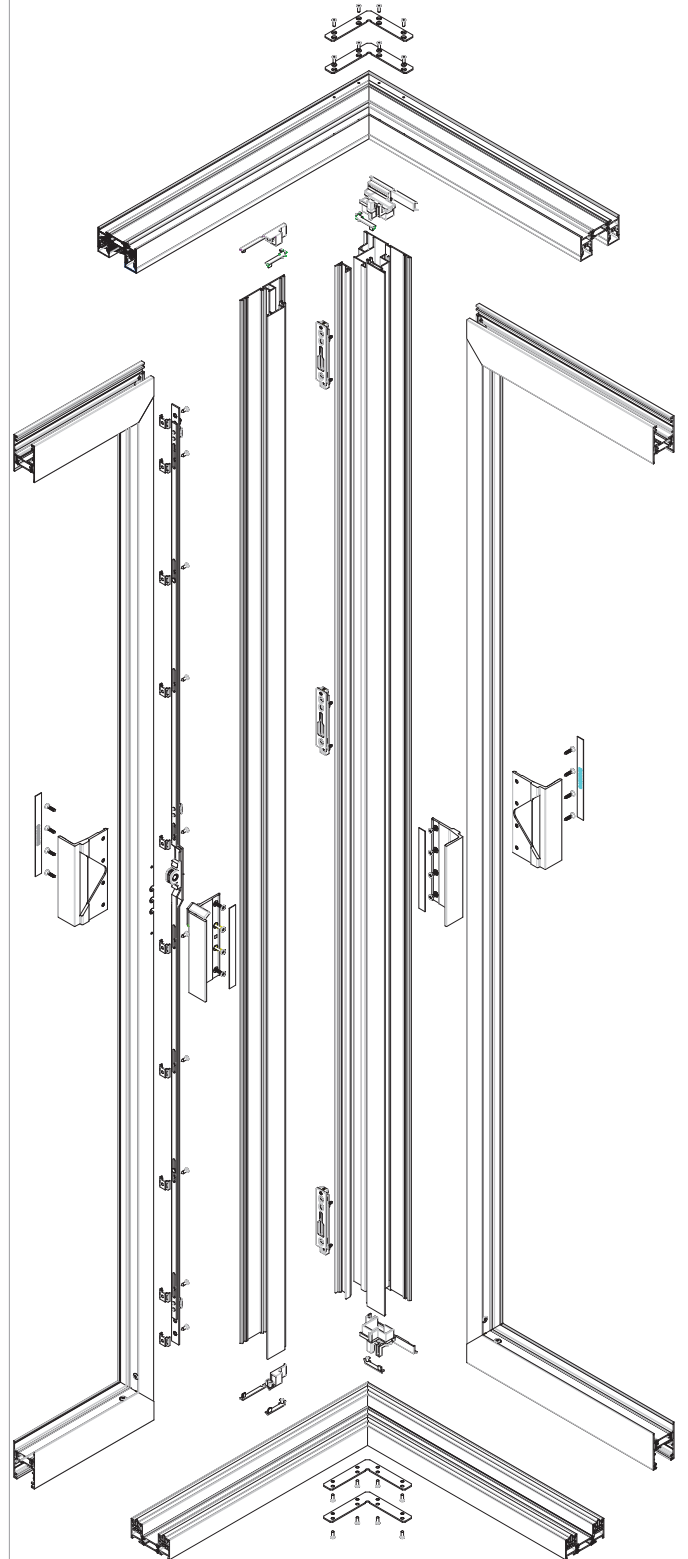

Detail of corner assembly doors

■ **MONTAGGIO 4 ANTA**
► 4th sash assembling

Esploso particolare di assemblaggio
KIT **ASX.85.KANG**

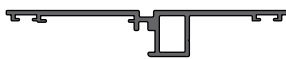
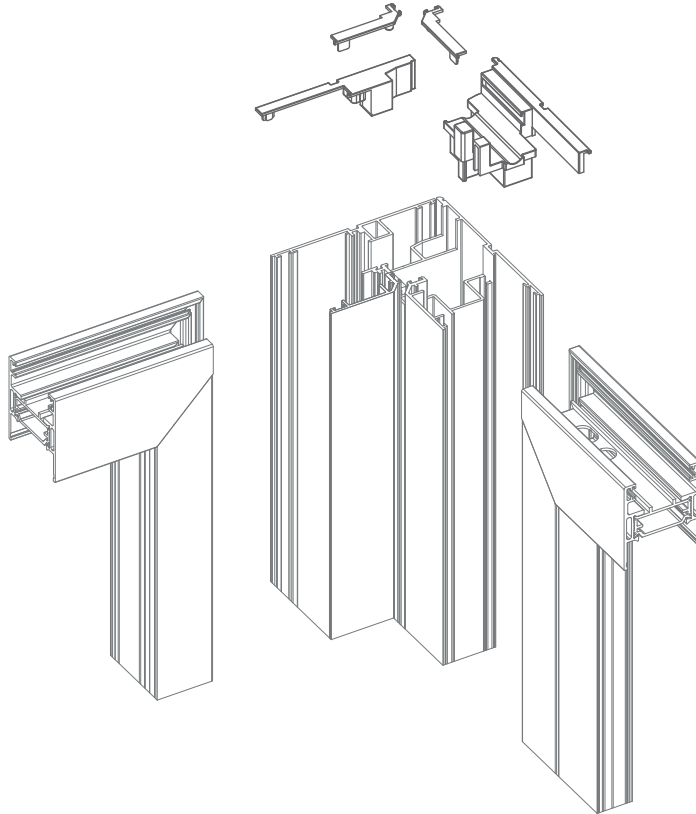

SX12.306



SX12.304

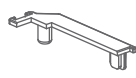
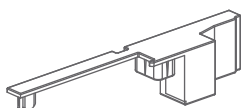
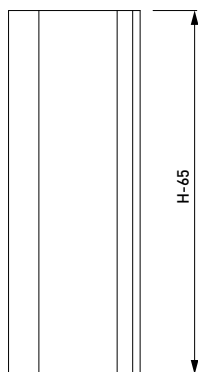
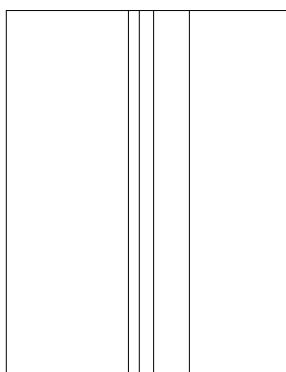

*Exploded view of the assembly detail
KIT ASX.85.KANG*

Particolare di assemblaggio
tappo profilo angolo **SX12.305**

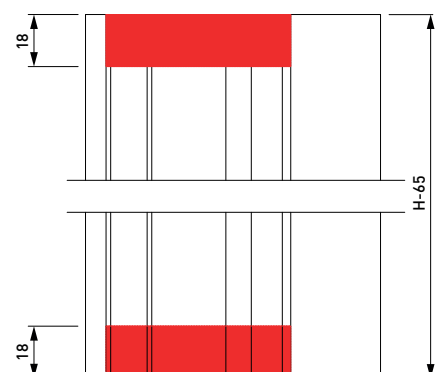
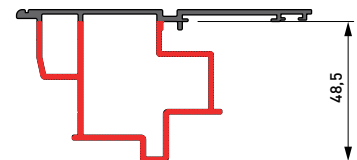
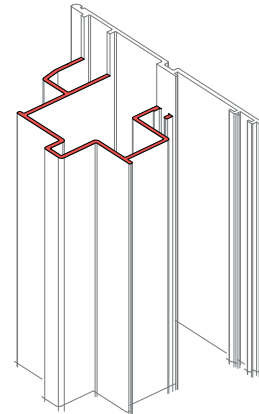
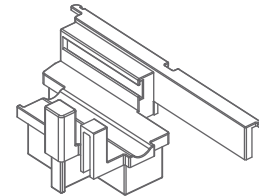

SX12.305

*Detail of corner assembly PLUG on
profile SX12.305*

■ **DETTAGLI DI LAVORAZIONE**
► **PROCESSING DETAILS**

VERSIONE MINIMALE
MINIMAL VERSION

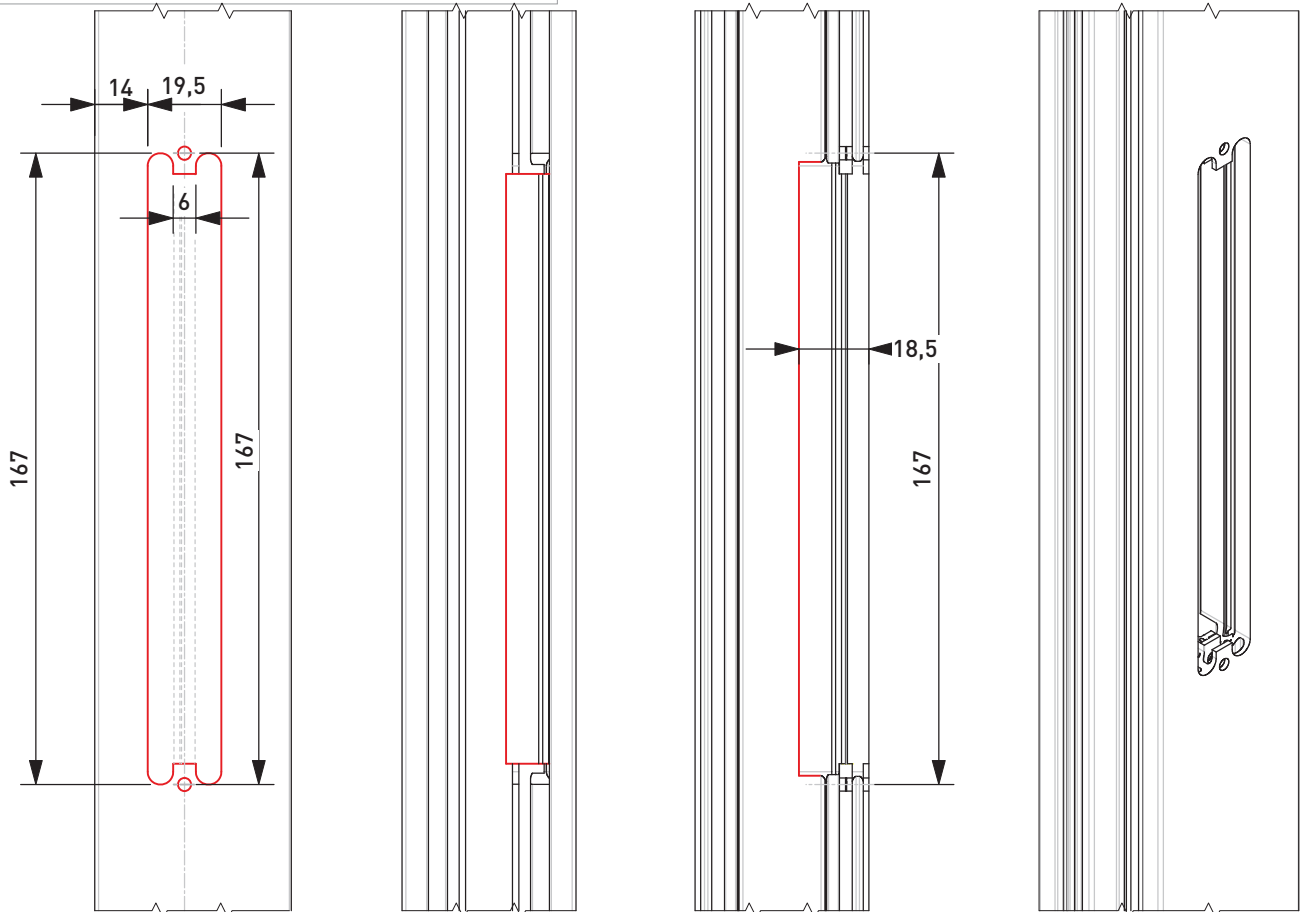
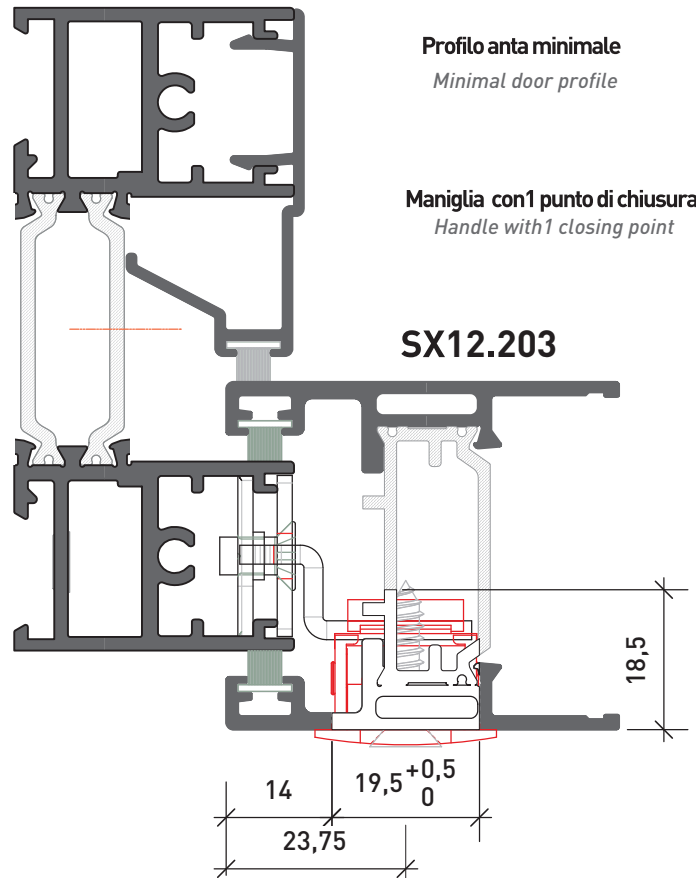
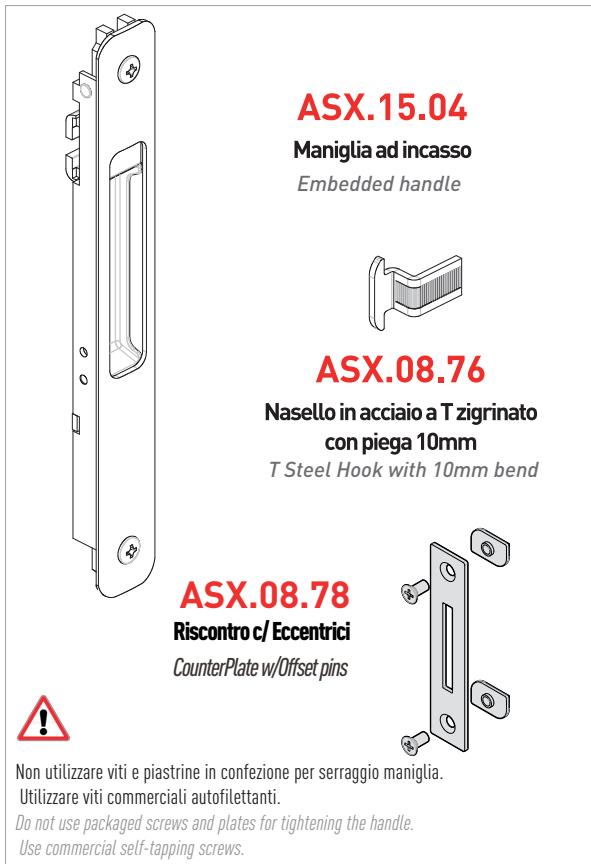

■ DETTAGLI DI LAVORAZIONE
▶ PROCESSING DETAILS

ANTA MAGGIORATA
OVERSIZED SASH

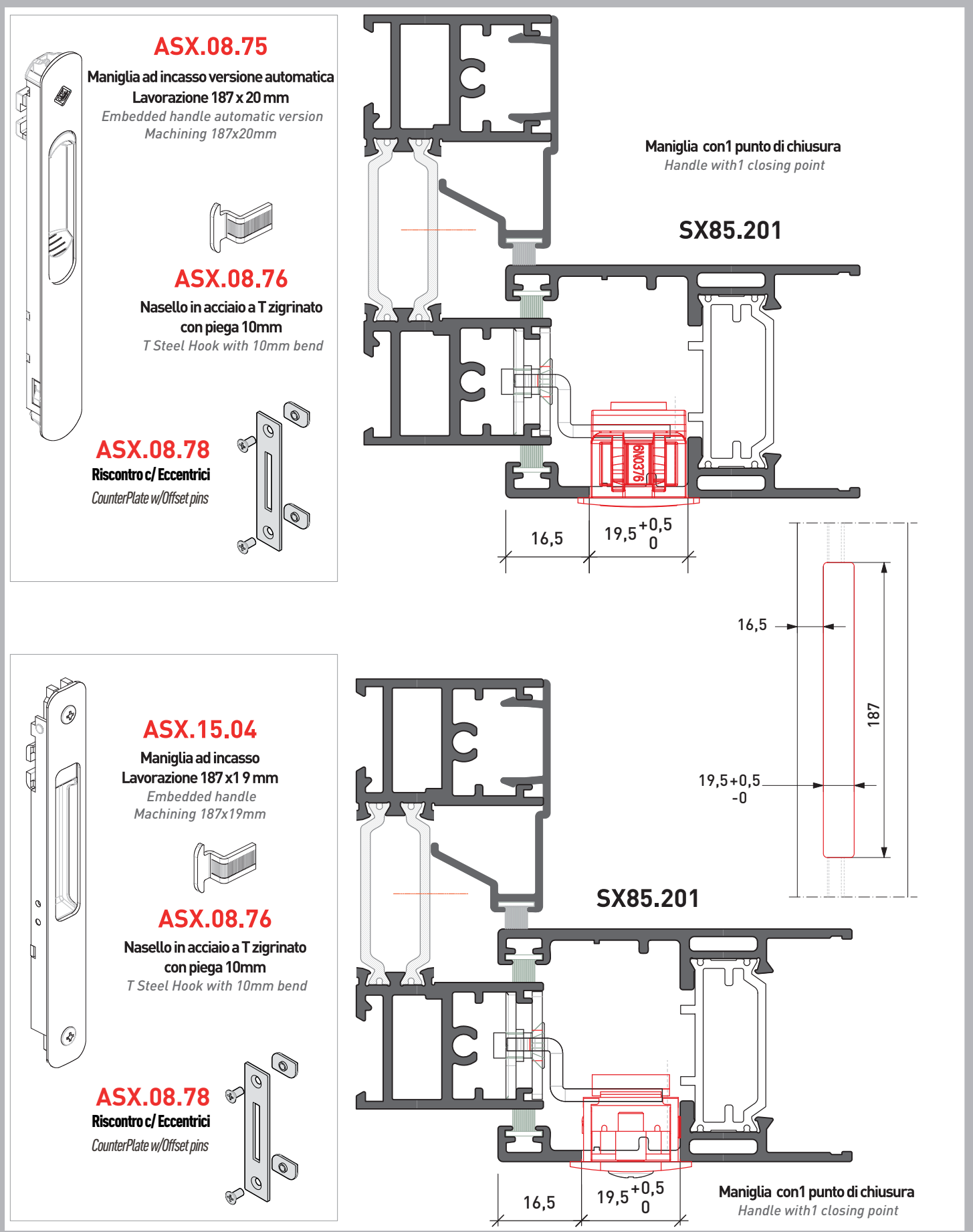



■ **DETTAGLI DI LAVORAZIONE**
► **PROCESSING DETAILS**

ANTA MAGGIORATA
OVERSIZED SASH

ASX.08.75

Maniglia ad incasso versione automatica
Lavorazione 187 x 20 mm
Embedded handle automatic version
Machining 187x20mm

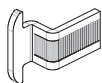

ASX.08.76

Nasello in acciaio a T zigrinato
con piega 10mm
T Steel Hook with 10mm bend

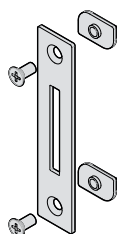

ASX.08.78

Riscontro c/ Eccentrici
CounterPlate w/Offset pins

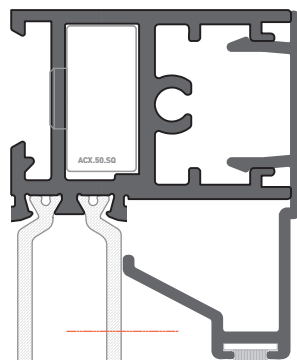

Maniglia con 1 punto di chiusura
Handle with 1 closing point

SX 85.206

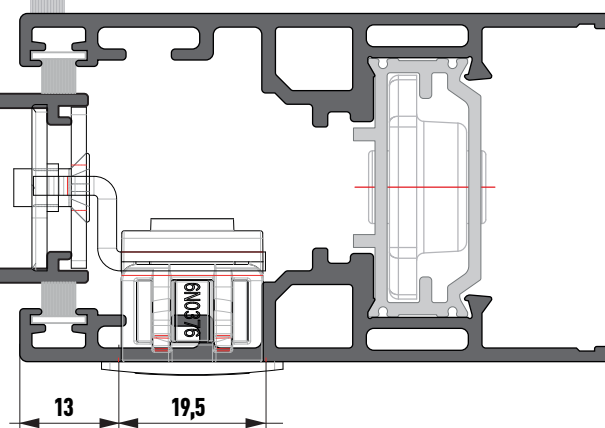

ASX.15.04

Maniglia ad incasso
Lavorazione 187 x 19 mm
Embedded handle
Machining 187x19mm

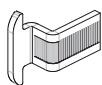
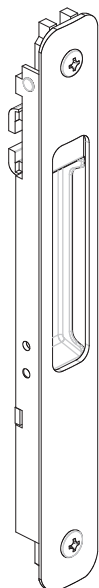

ASX.08.76

Nasello in acciaio a T zigrinato
con piega 10mm
T Steel Hook with 10mm bend

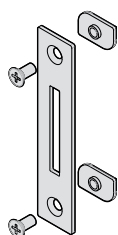

ASX.08.78

Riscontro c/ Eccentrici
CounterPlate w/Offset pins

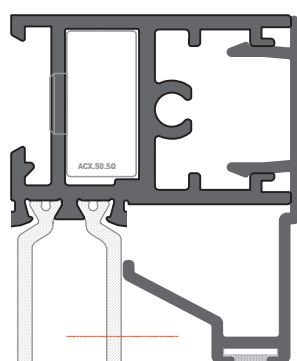

Maniglia con 1 punto di chiusura
Handle with 1 closing point

SX 85.206

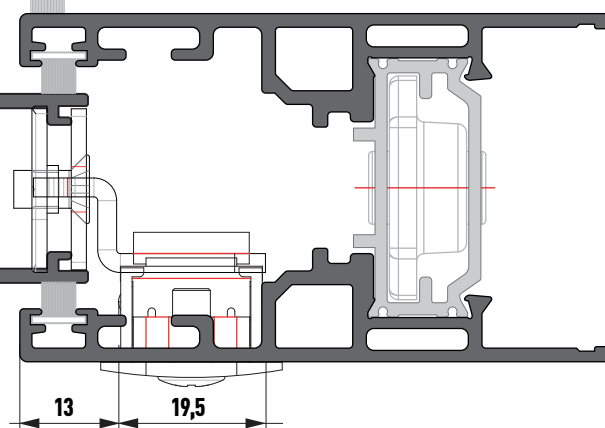

■ **DETTAGLI DI LAVORAZIONE**
► **PROCESSING DETAILS**

VERSIONE MINIMALE
MINIMAL VERSION



ACX.08.71SX
Martellina SX con manico
disassato, L quadro 26 mm
*Offset handle, panel
projection 26 mm.*



ACX.08.60
Martellina sporgenza
quadro 26 mm
*Handle panel projection
26 mm*

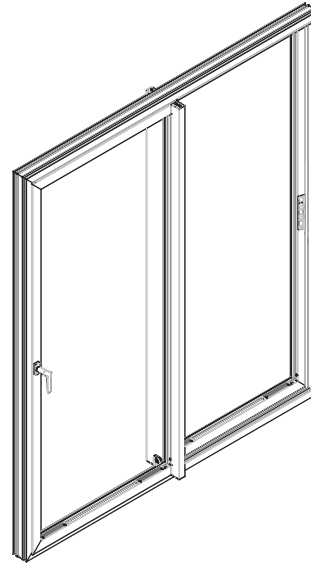

Maniglia con chiusura multipunto
*Handle with multi-point
closure*

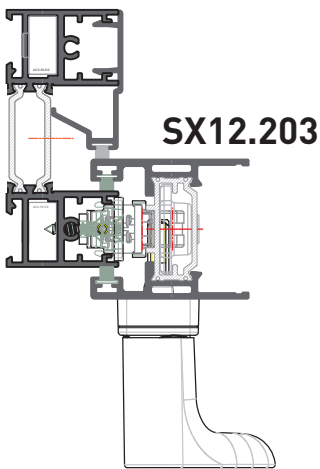

SX12.203

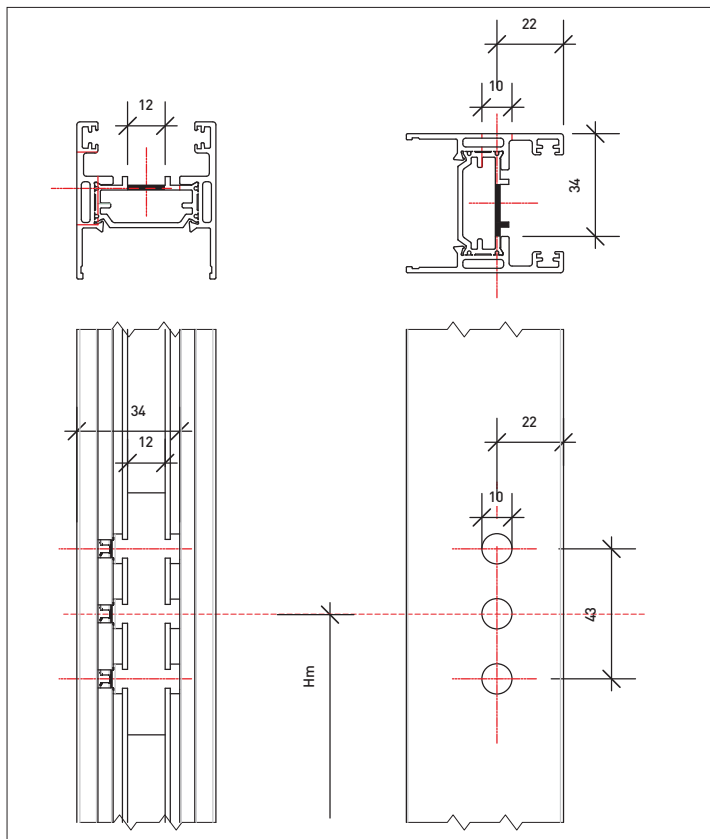
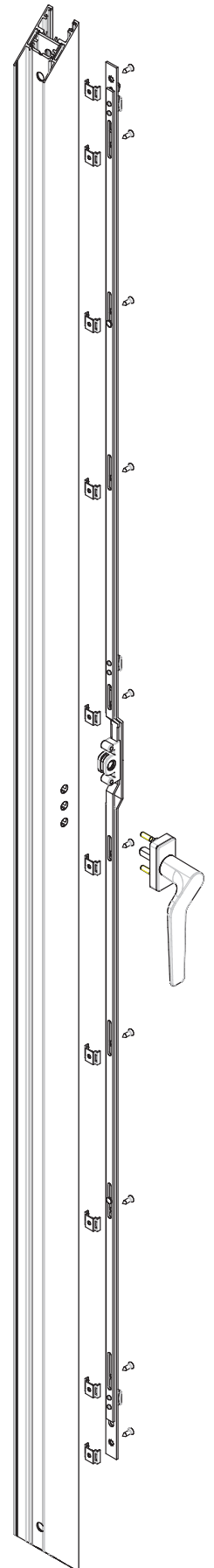
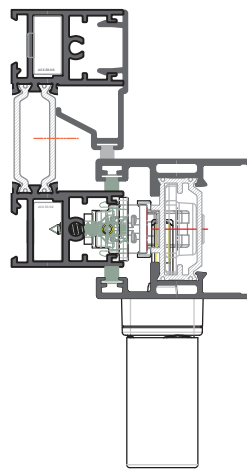

Aggiungere Cover ASX.08.80
Add covers ASX.08.80

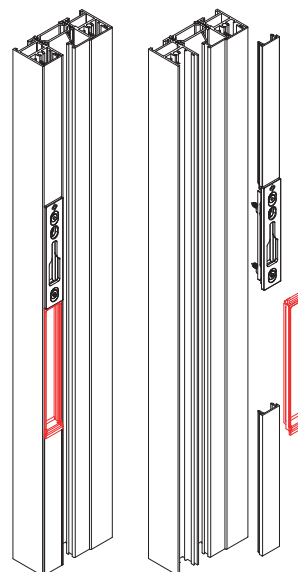

DETTAGLI DI LAVORAZIONE

► **PROCESSING DETAILS**

VERSIONE MINIMALE
MINIMAL VERSION



ACX.08.71SX
Martellina SX con manico disassato, L quadro 26 mm
Offset handle, panel projection 26 mm.



ACX.08.60
Martellina sporgenza quadro 26 mm
Handle panel projection 26 mm



ASX.08.73
Maniglia di traino esterna
External pull handle

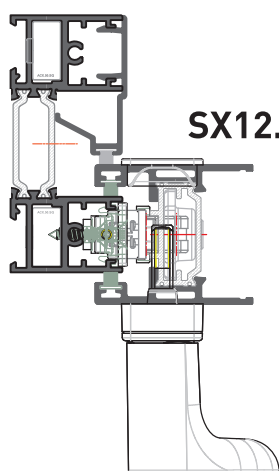
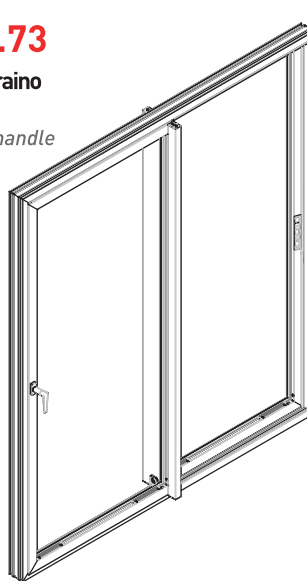

SX12.203

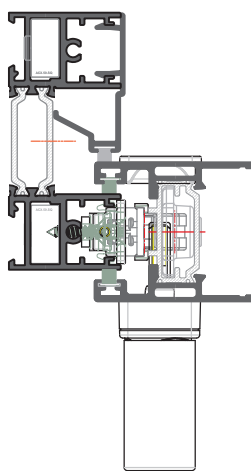

Maniglia con chiusura multipunto
Handle with multi-point closure

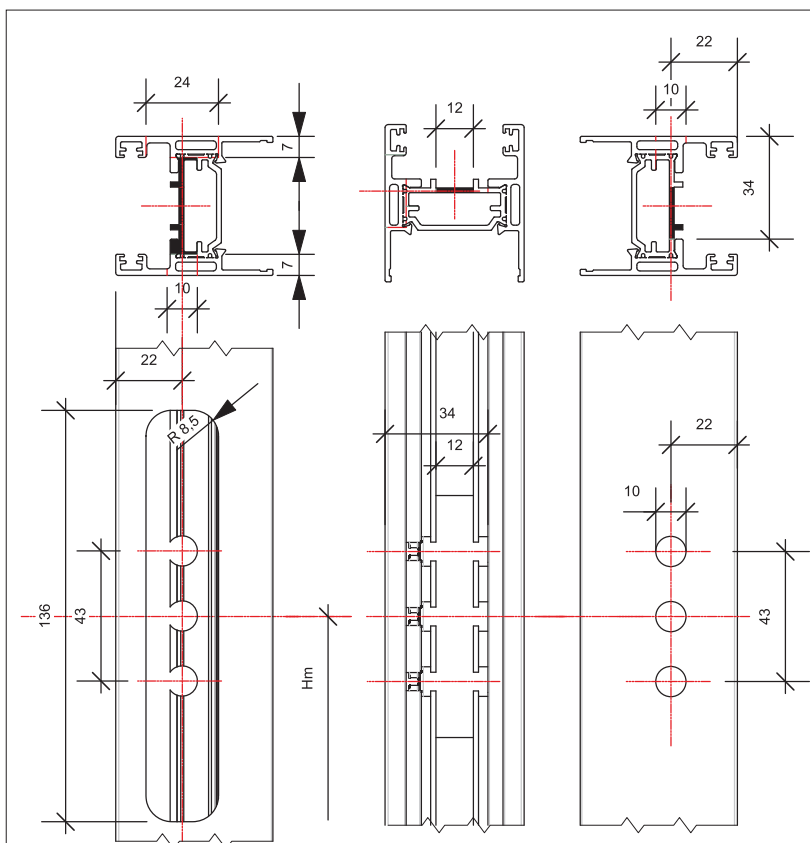

Aggiungere Cover ASX.08.80
Add covers ASX.08.80

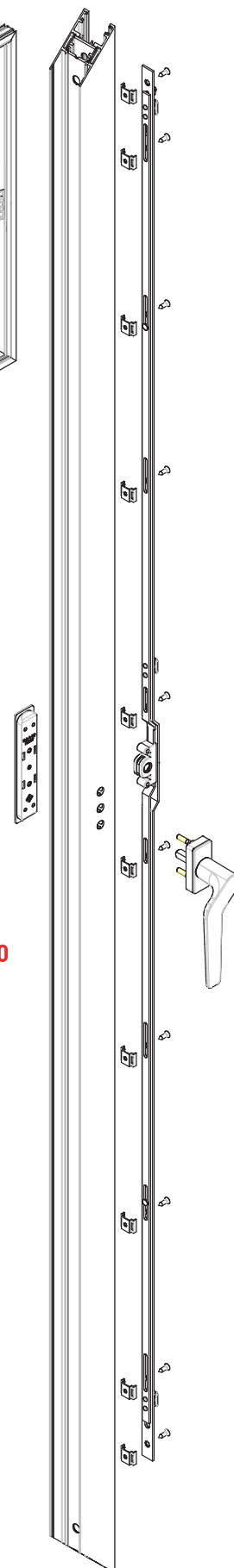
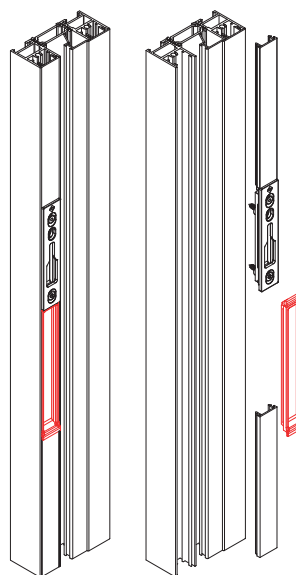

■ **DETTAGLI DI LAVORAZIONE**
► **PROCESSING DETAILS**

VERSIONE MINIMALE
MINIMAL VERSION

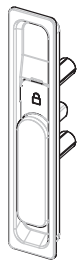

ASX.08.74

Maniglia ad incasso
sporgenza quadro 21,5 mm
Embedded handle - square
projection 21,5 mm

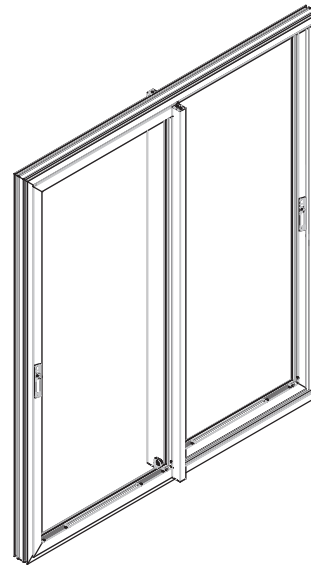

SX12.203

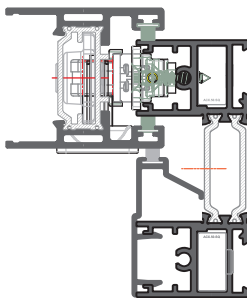

Maniglia con chiusura multipunto
Handle with multi-point closure

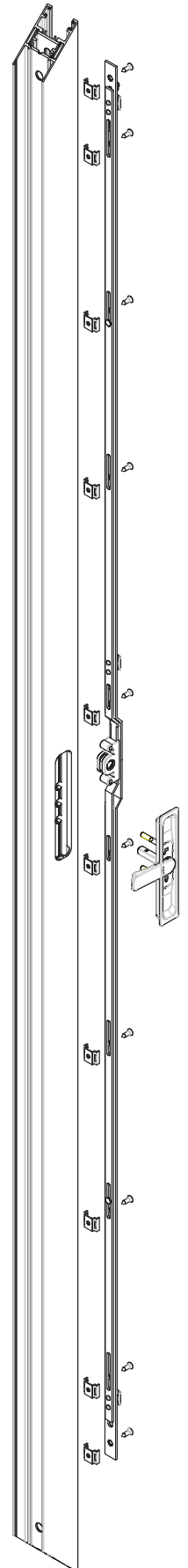

Aggiungere Cover ASX.08.80
Add covers ASX.08.80

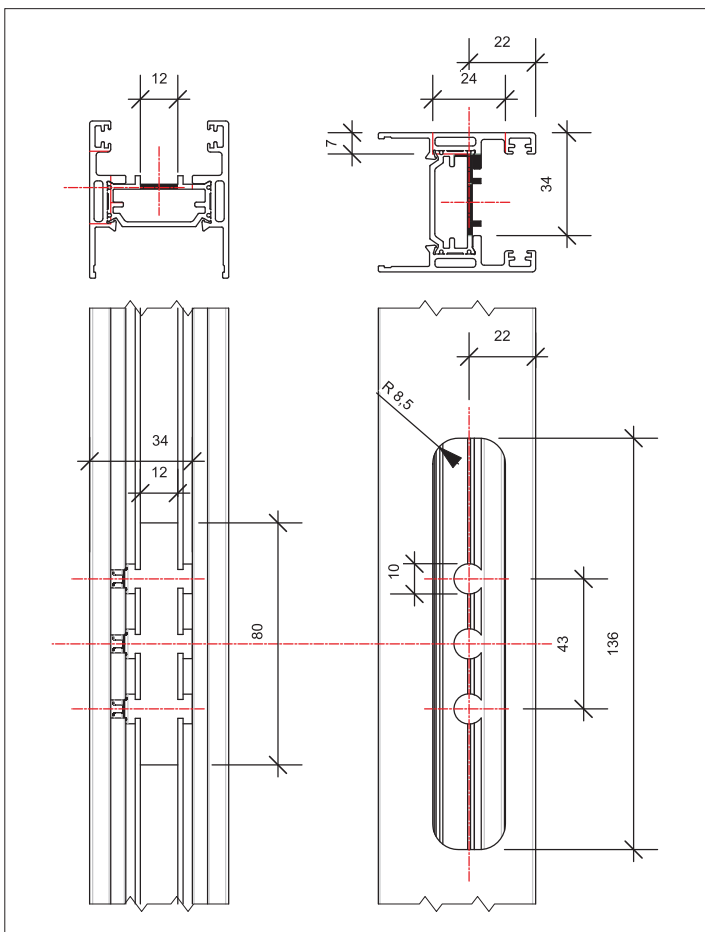
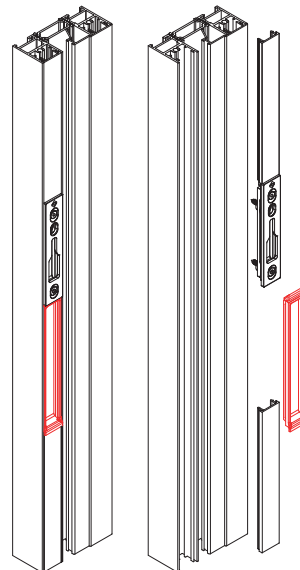

DETTAGLI DI LAVORAZIONE
PROCESSING DETAILS

ASX.12.FAST60

Foratura per contropiastra - Drilling for counter plate

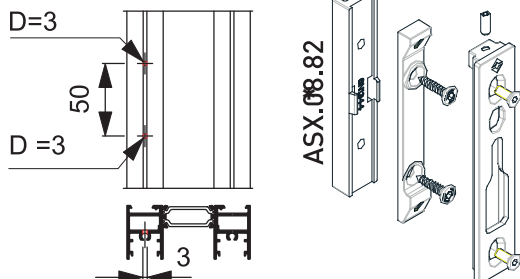

*Usare sempre con Fastlock versione INOX | Opzionale versione ZINCATA
*Must be used with Fastlock INOX version | Opzional with ZINC-PLATED

Montaggio contropiastra - Mounting counterplate

H1	H2	H3
Hm - 268	Hm + 205	-

Taglio - Cut ASX 10.26

A	B	C	D
Hm - 290	103.5	125	Ha - (Hm+302)
Hm - 490	303	324	Ha - (Hm+501)
Hm - 890	703	612	Ha - (Hm+901)

Dimensioni minime - Minimum size

Codice	L	E	Hm (minima)	H anta (minima)
ASX.12.FAST60	600	7.5	400	800

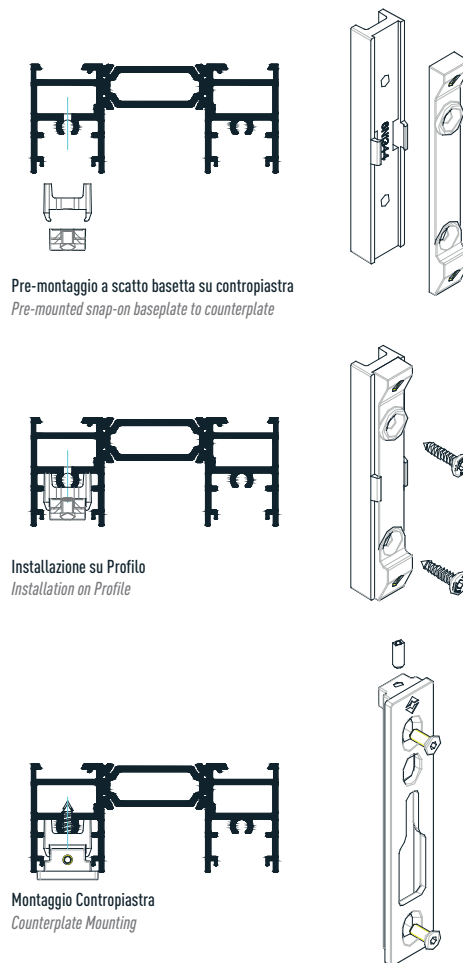
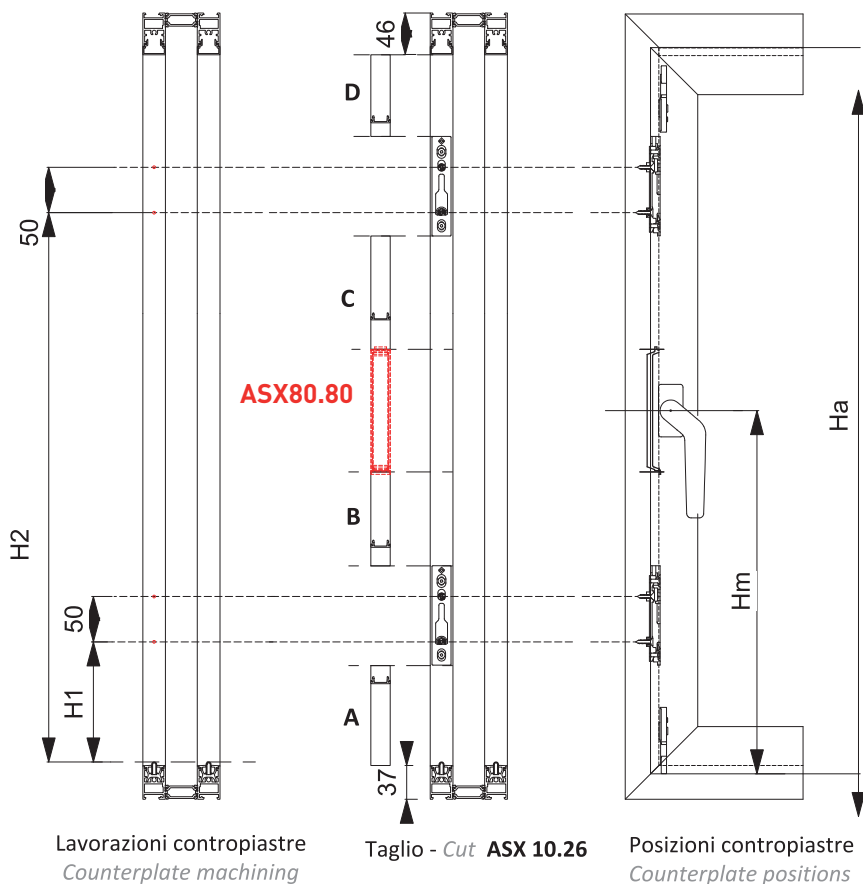

Verificare il taglio di **ASX 10.26** dopo aver effettuato la regolazione
Check the cut of the cover after the adjustment has been made

■ DETTAGLI DI LAVORAZIONE
► PROCESSING DETAILS

VERSIONE MINIMALE
MINIMAL VERSION

ASX.12.FAST100

Foratura per contropiastra - Drilling for counter plate

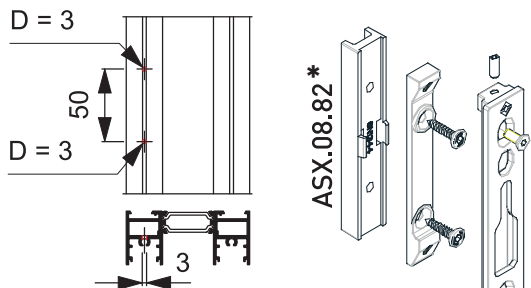

*Usare sempre con Fastlock versione INOX | Opzionale versione ZINCATA
*Must be used with Fastlock INOX version | Opzional with ZINC-PLATED

Taglio - Cut ASX 10.26

A	B	C	D
Hm - 290	103.5	125	Ha - (Hm+302)
Hm - 490	303	324	Ha - (Hm+501)
Hm - 890	703	612	Ha - (Hm+901)

Dimensioni minime - Minimum size

Codice	L	E	Hm (minima)	H anta (minima)
ASX.12.FAST100	1000	7.5	600	1200

Montaggio contropiastra - Mounting counterplate

H1	H2	H3
Hm - 468	Hm + 417	-

Lavorazioni contropiastre
Counterplate machining

Taglio - Cut ASX 10.26

Posizioni contropiastre
Counterplate positions

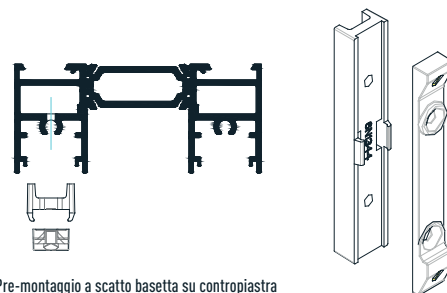
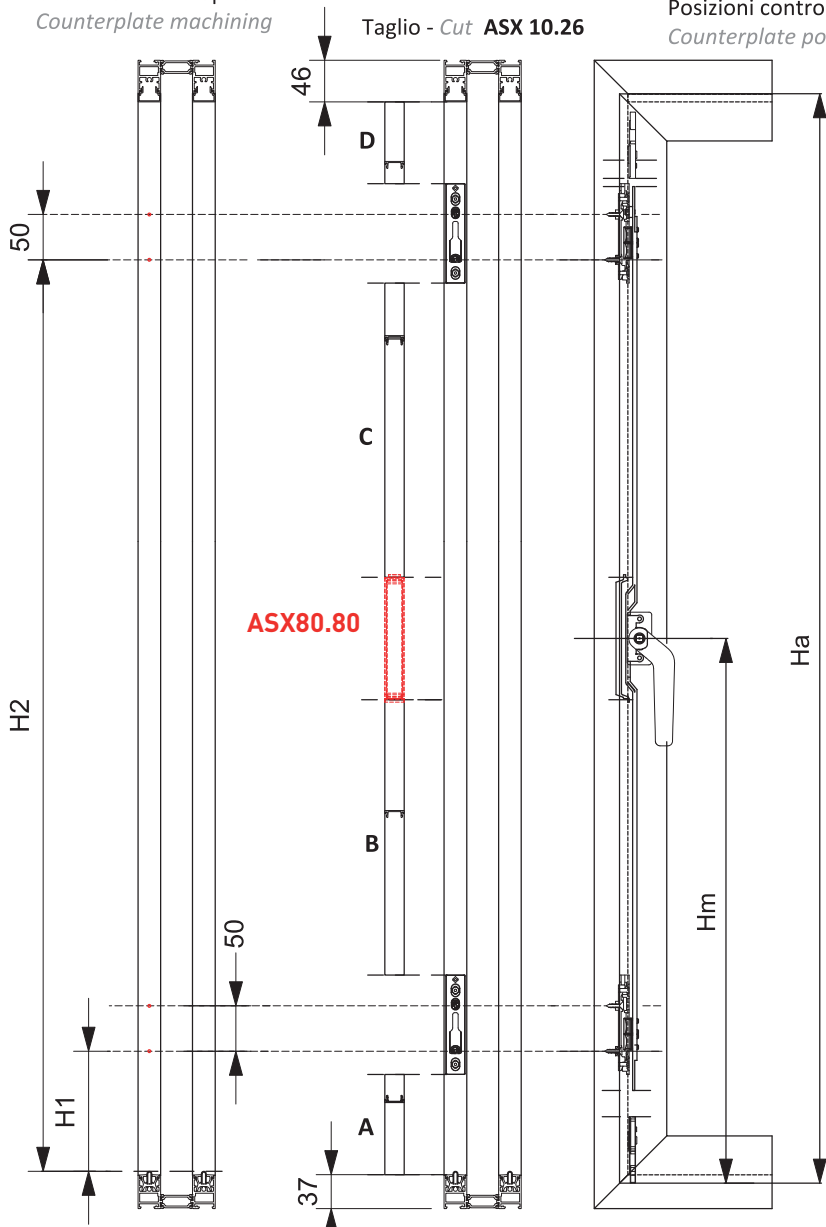

Pre-montaggio a scatto basetta su contropiastra
Pre-mounted snap-on baseplate to counterplate

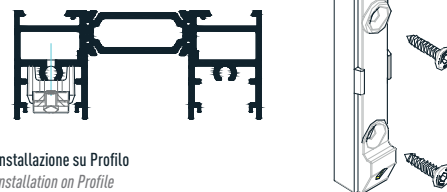

Installazione su Profilo
Installation on Profile

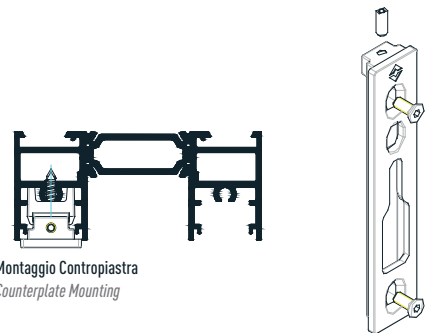

Montaggio Contropiastra
Counterplate Mounting

Verificare il taglio di ASX 10.26 dopo aver effettuato la regolazione
Check the cut of the cover after the adjustment has been made

DETTAGLI DI LAVORAZIONE
PROCESSING DETAILS

VERSIONE MINIMALE
MINIMAL VERSION

ASX.12.FAST180

Foratura per contropiastra
Drilling for counter plate

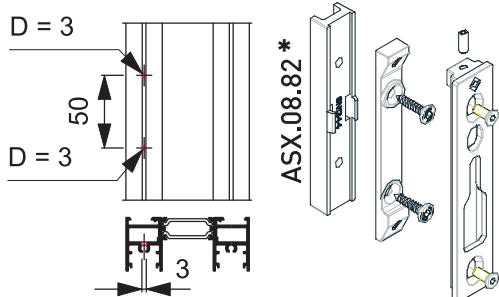

*Usare sempre con Fastlock versione INOX | Opzionale versione ZINCATA
*Must be used with Fastlock INOX version | Opzional with ZINC-PLATED

Montaggio contropiastra - Mounting counterplate

H1	H2	H3
Hm - 868	Hm + 94	Hm + 816

Taglio - Cut ASX 10.26

A	B	C	D
Hm - 290	103.5	125	Ha - (Hm+302)
Hm - 490	303	324	Ha - (Hm+501)
Hm - 890	703	612	Ha - (Hm+901)

Dimensioni minime - Minimum size

Codice	L	E	Hm (minima)	H anta (minima)
ASX.12.FAST180	1800	7.5	1000	2000

Verificare il taglio di **ASX 10.26** dopo aver effettuato la regolazione
Check the cut of the cover after the adjustment has been made

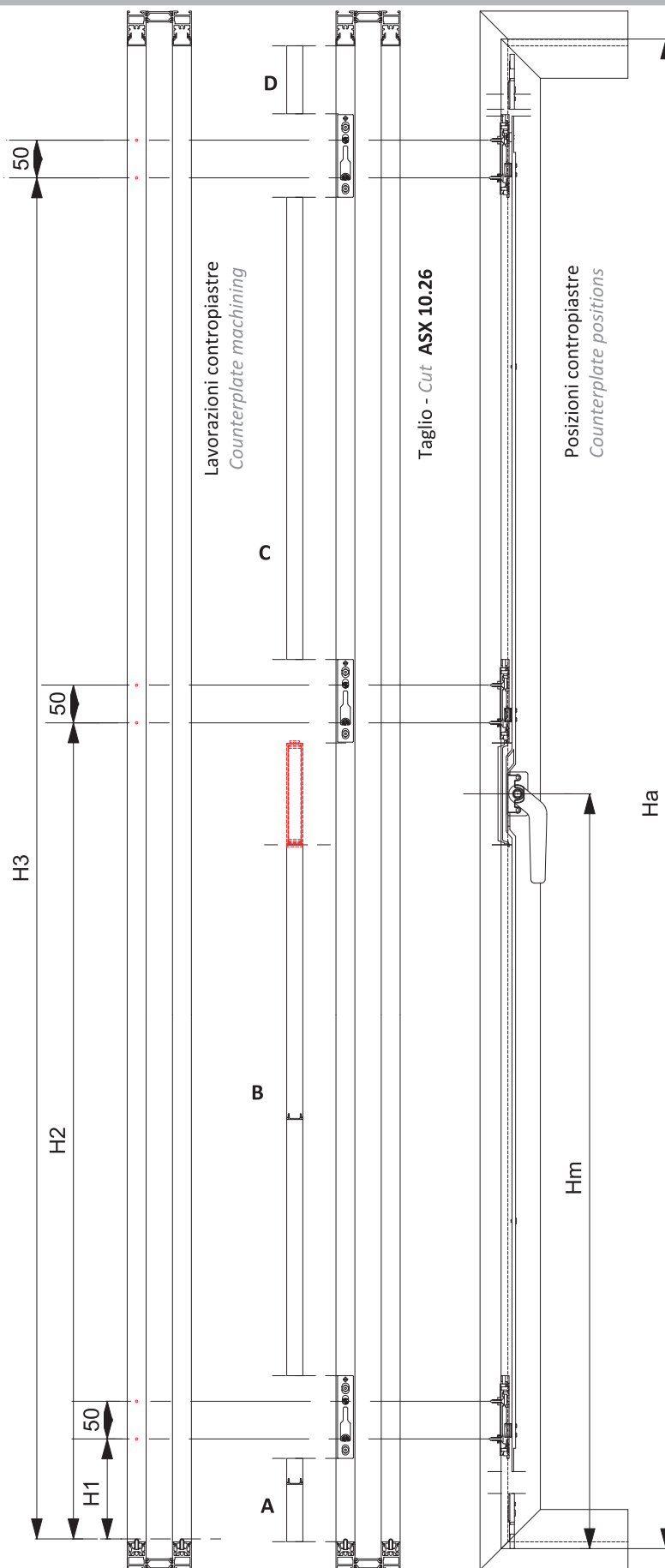



■ **DETTAGLI DI LAVORAZIONE**

► **PROCESSING DETAILS**

VERSIONE MINIMALE
MINIMAL VERSION

Lavorazione per montaggio aste **Fastlock** su anta minimale
*Machining for mounting **Fastlock** rods on minimal sash*

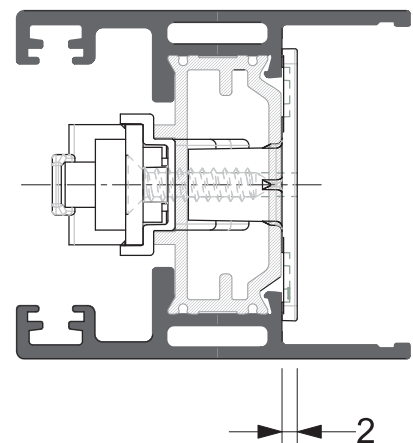
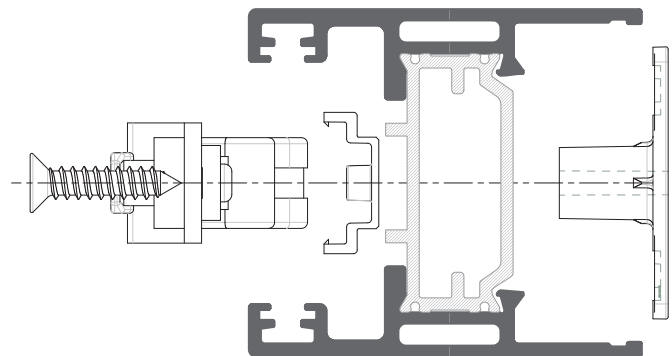
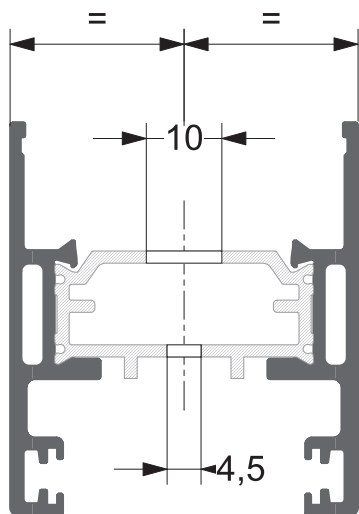
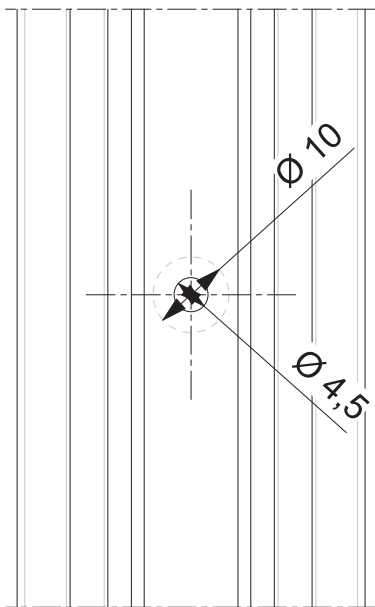



■ **DETTAGLI DI LAVORAZIONE**

► **PROCESSING DETAILS**

VERSIONE MINIMALE
MINIMAL VERSION

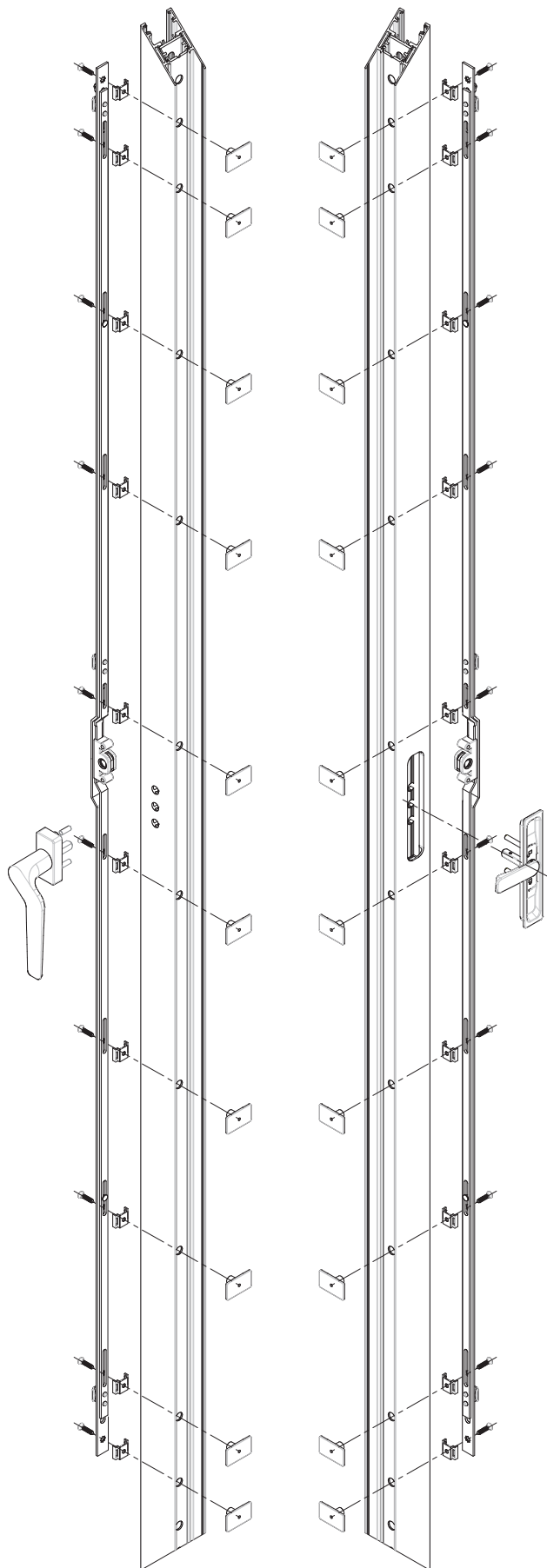

Montaggio aste **Fastlock** su anta minimale
*Mounting **Fastlock** rods on minimal sash*

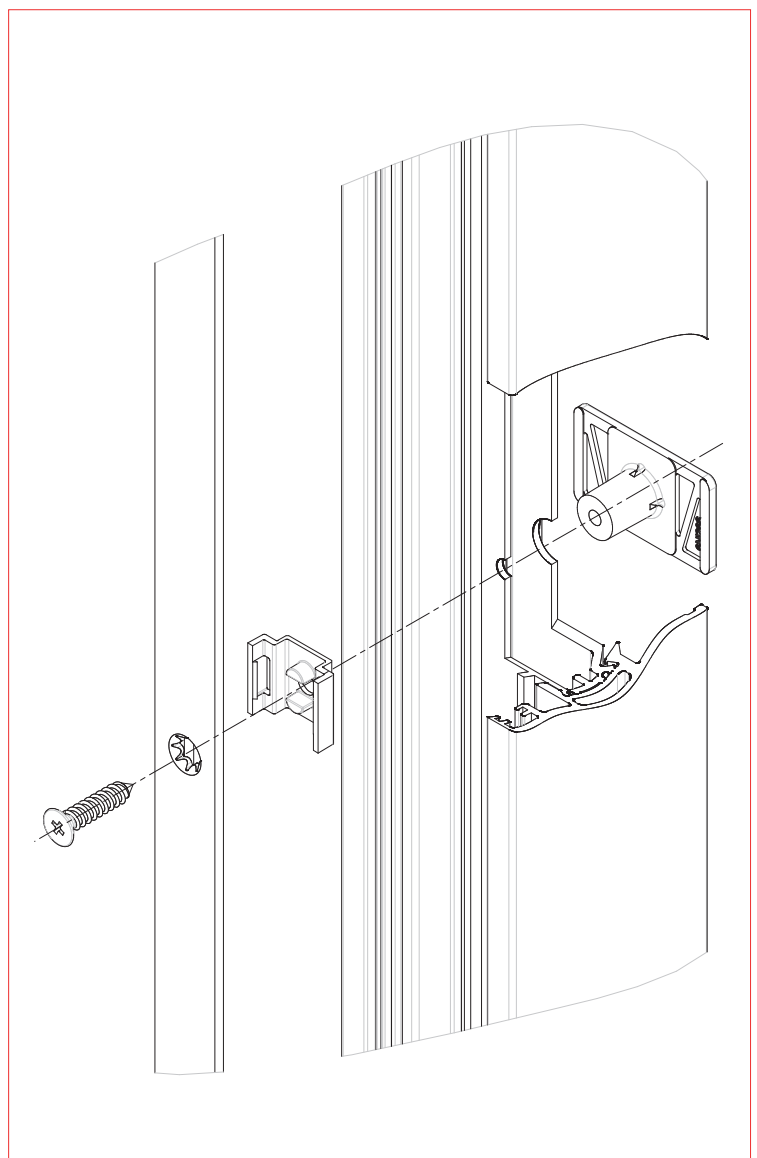

■ **DETTAGLI DI LAVORAZIONE**

► **PROCESSING DETAILS**



ANTA MAGGIORATA
OVERSIZED SASH

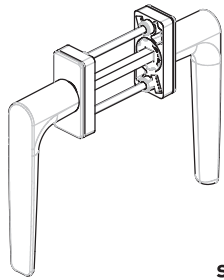

ACX.08.72

Doppia martellina per sezioni profilo fino a 64 mm
Two-side cremone bolt for profile sections up to 64 mm.

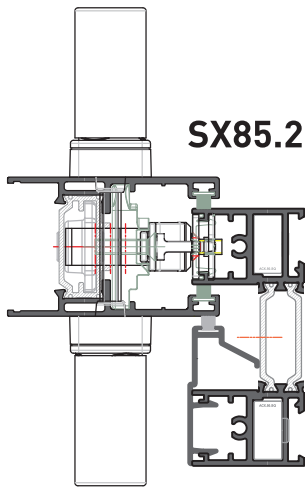

SX85.201

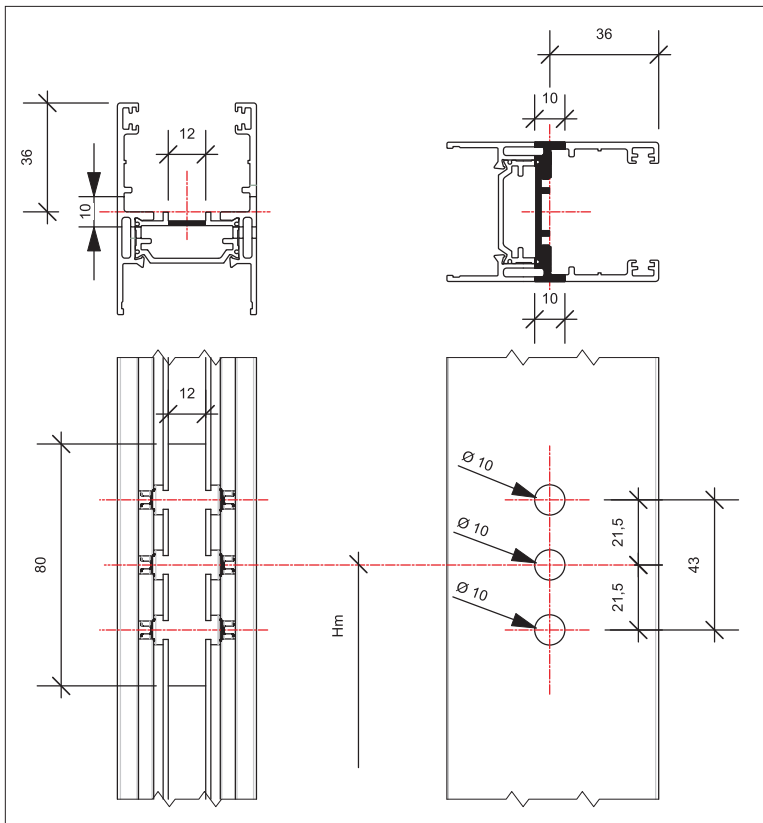
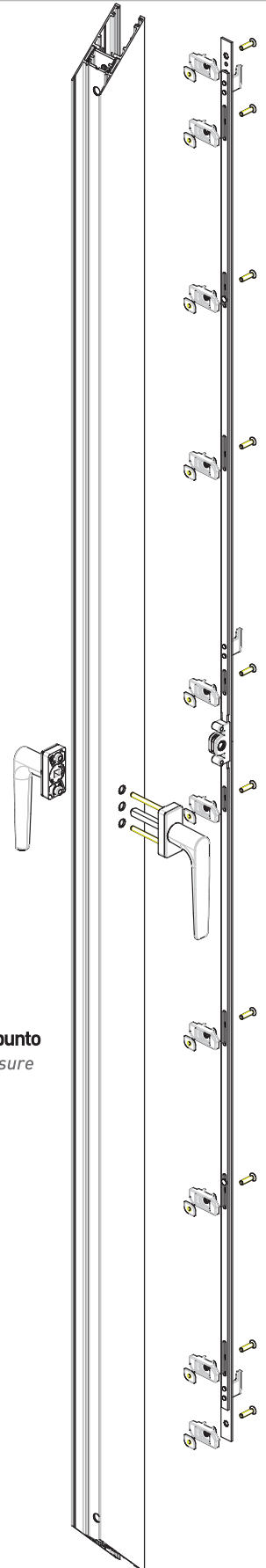
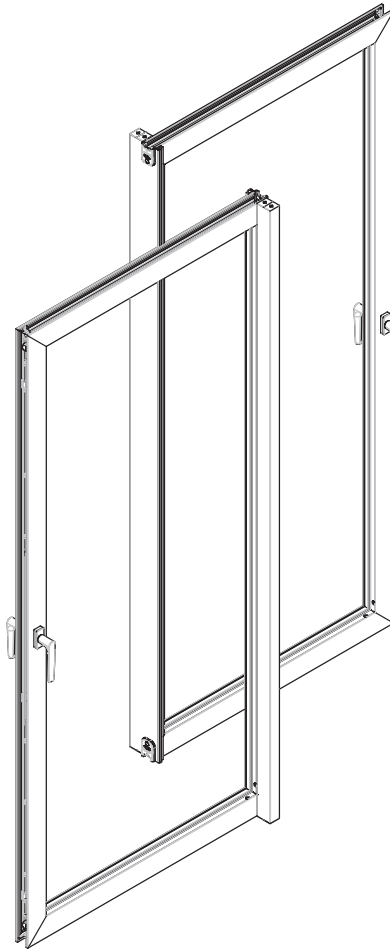

Maniglia con chiusura multipunto
Handle with multi-point closure

■ **DETTAGLI DI LAVORAZIONE**
► **PROCESSING DETAILS**

ANTA MAGGIORATA
OVERSIZED SASH

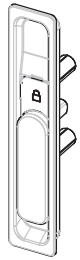

ASX.08.74
Maniglia ad incasso
sporgenza quadro 21,5 mm
*Embedded handle - square
projection 21,5 mm*

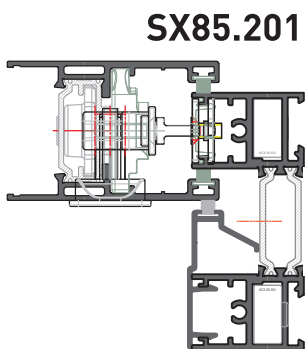

SX85.201

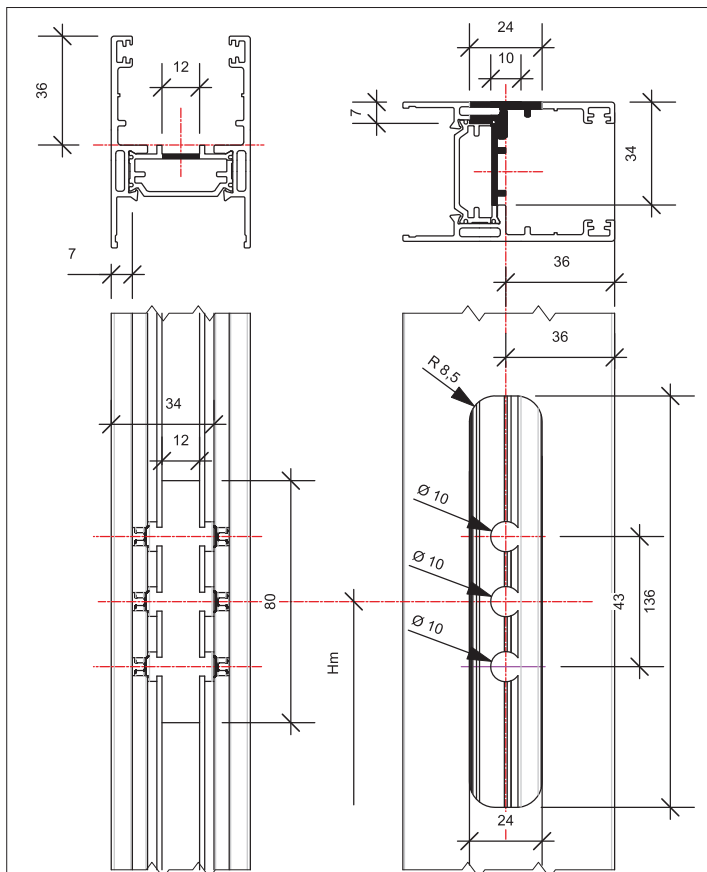
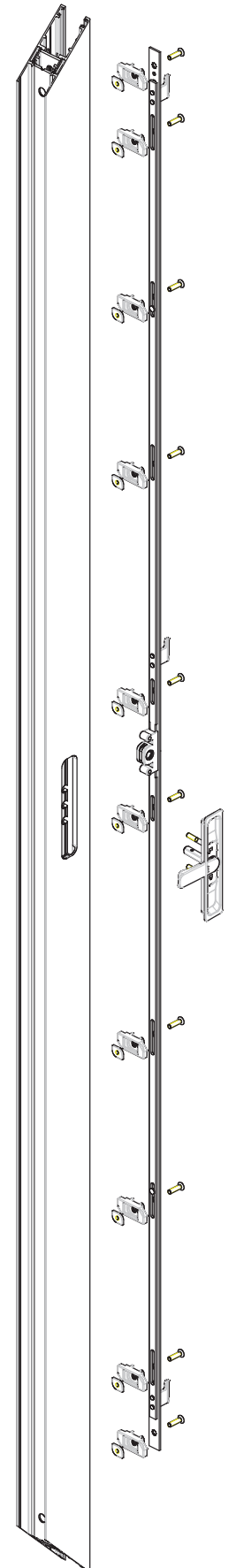
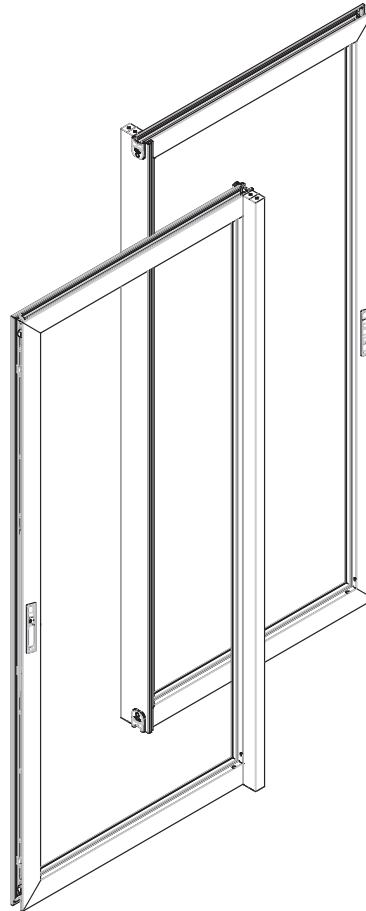

Maniglia con chiusura multipunto
Handle with multi-point closure

■ **DETTAGLI DI LAVORAZIONE**
► **PROCESSING DETAILS**

ANTA MAGGIORATA
OVERSIZED SASH



ASX.08.74

Maniglia ad incasso
sporgenza quadro 21,5 mm
Embedded handle - square
projection 21,5 mm

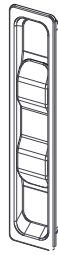

ASX.08.73

Maniglia di Traino
External Pull Washer

SX85.201

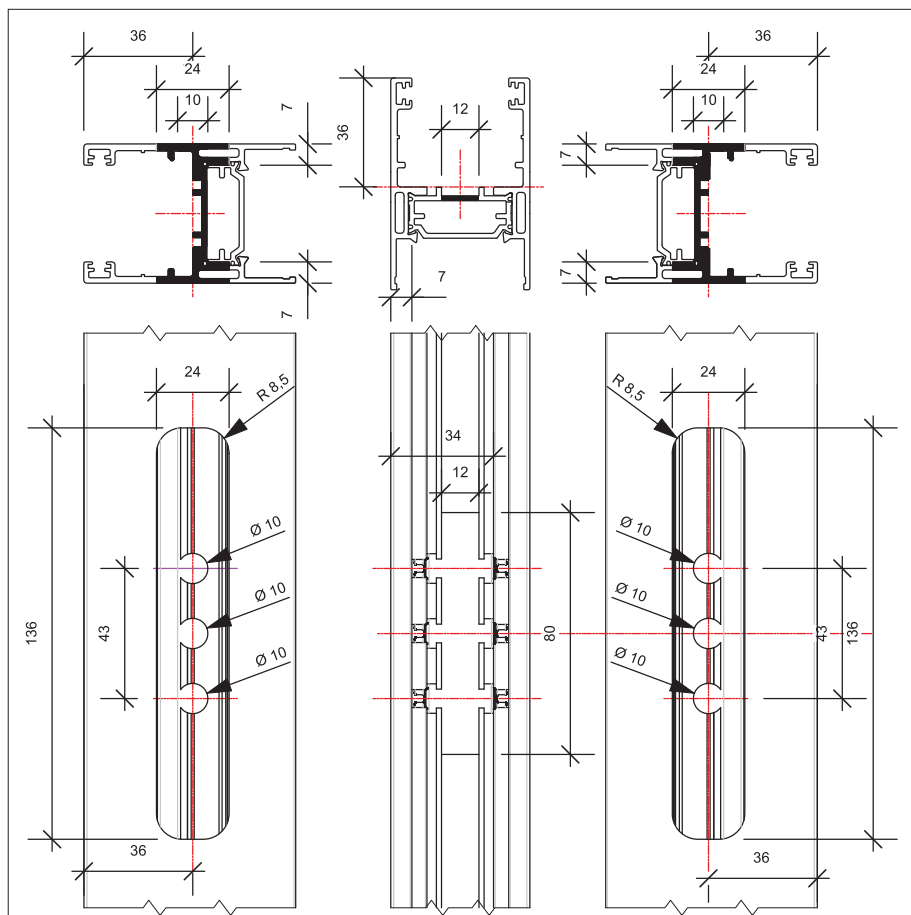
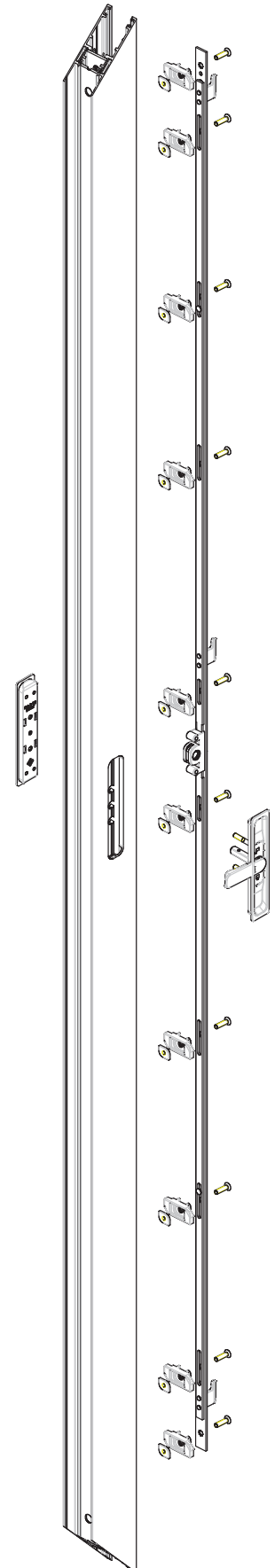
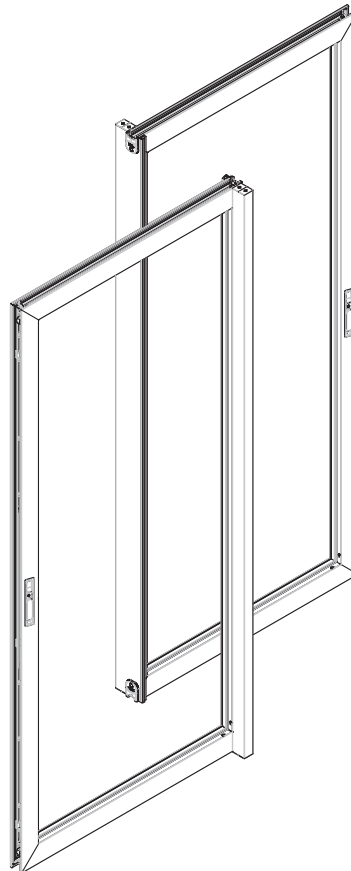
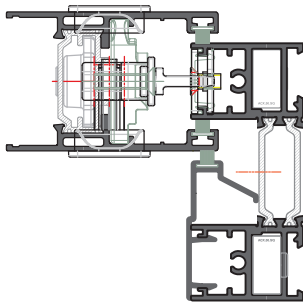



■ **DETTAGLI DI LAVORAZIONE**

► **PROCESSING DETAILS**

ASX 12.ANGFIS

Fissaggio anta fissa

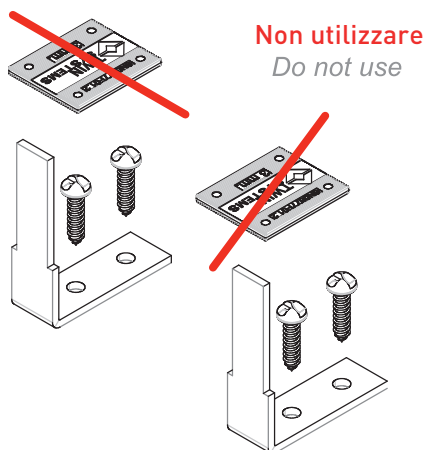

Bloccaggio staffa SUPERIORE
UPPER Bracket Fixing

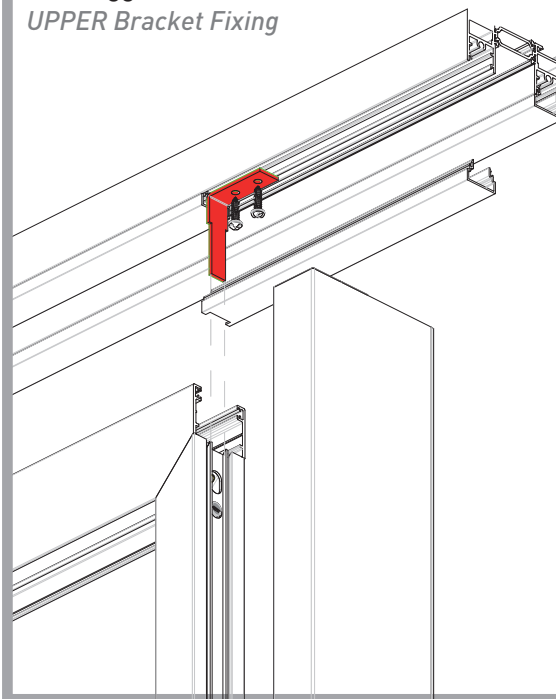

Soluzione con anta minimale
Utilizzare il profilo SX85.501 come sostegno (a pezzi)
Minimal door solution
Use the SX85.501 profile as a support (in pieces)

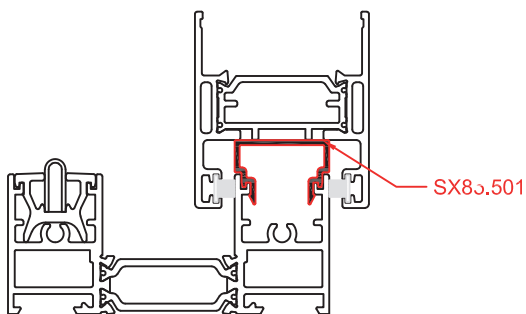

Soluzione con anta maggiorata
Utilizzare il profilo SX85.501 come sostegno (a pezzi) ed articolo 6742.18
Oversized sash solution
Use the SX85.501 profile as a support (in pieces) and article 6742.1

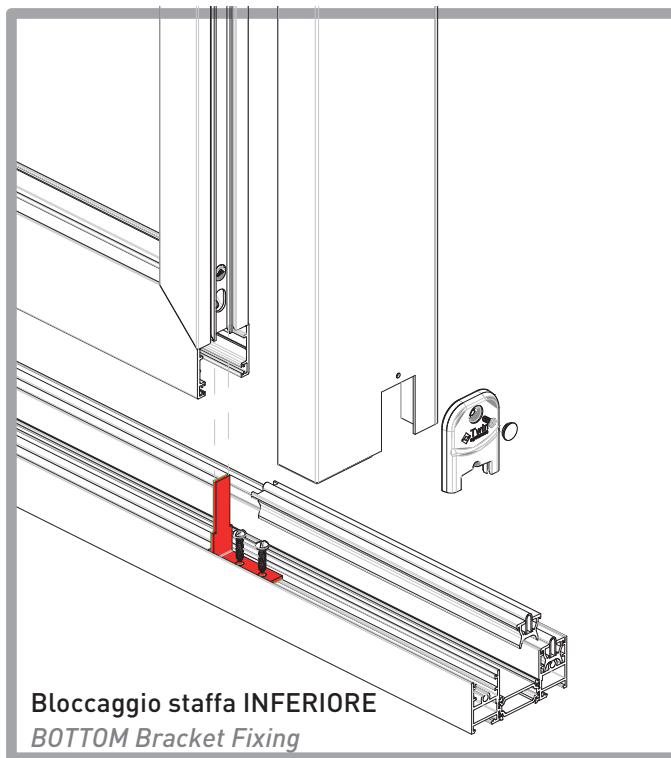
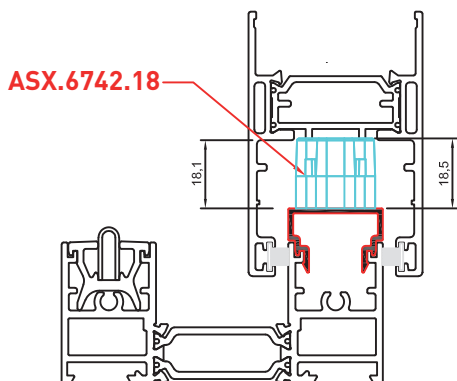

Bloccaggio staffa INFERIORE
BOTTOM Bracket Fixing



Sigillare perimetralmente
Perimential Sealing

■ **PROCESSO DI MONTAGGIO**

► **ASSEMBLING PROCESS**

ASX.08.77

Accessorio per fissaggio
profilo SX11.176 (coppia)
Accessory for fixing profile
SX11.176 (couple)

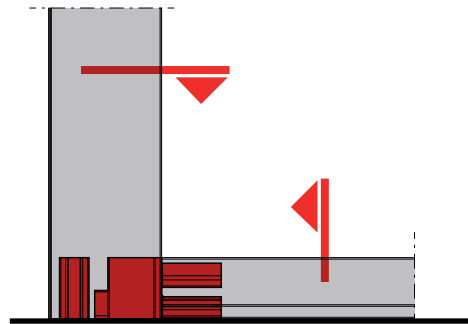

Prospetto Laterale
Side View

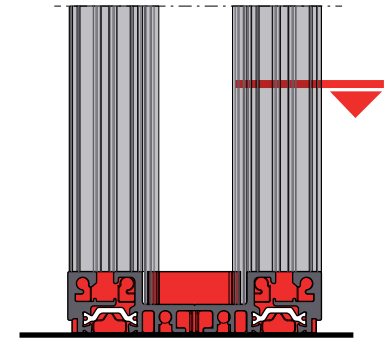

Sezione Verticale
Vertical Section

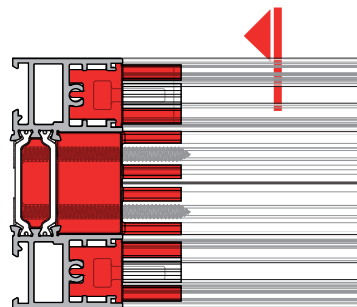

Sezione Orizzontale
Horizontale Section

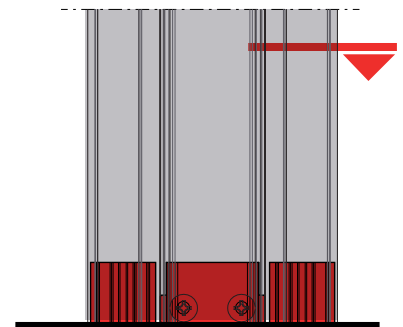

Vista Posteriore
Back View

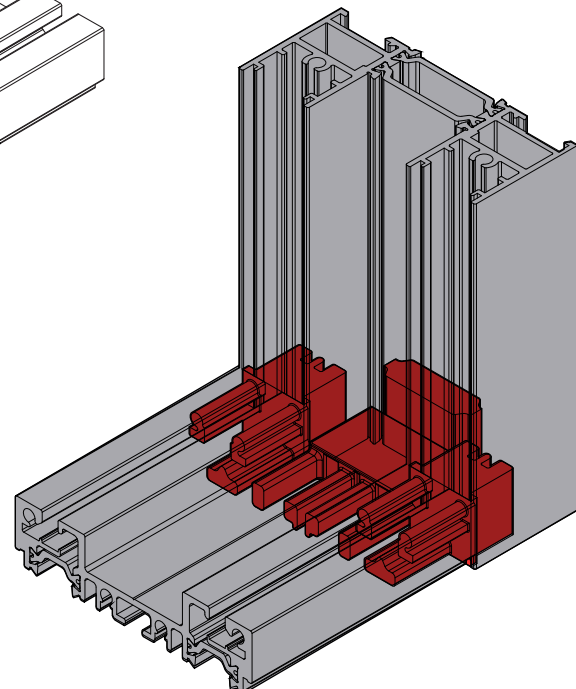
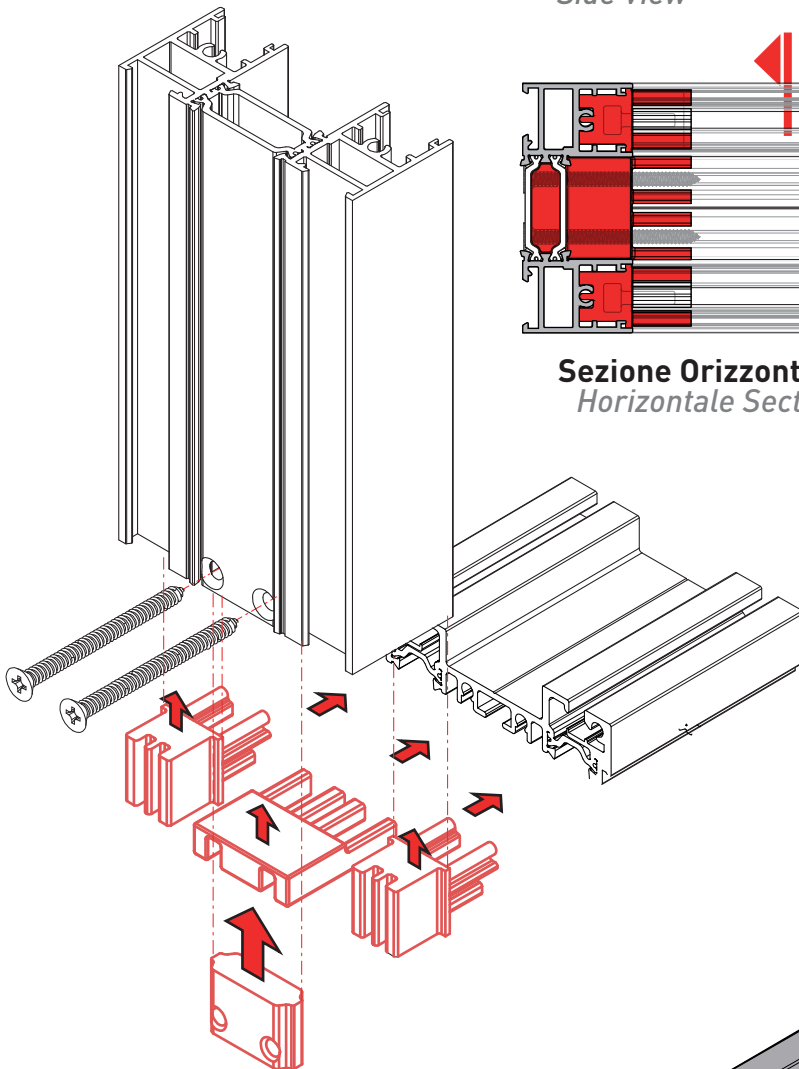

ATTENZIONE | ATTENTION
VITERIA NON INCLUSA | SCREWS NOT INCLUDED

■ **PROCESSO DI MONTAGGIO**

► **ASSEMBLING PROCESS**

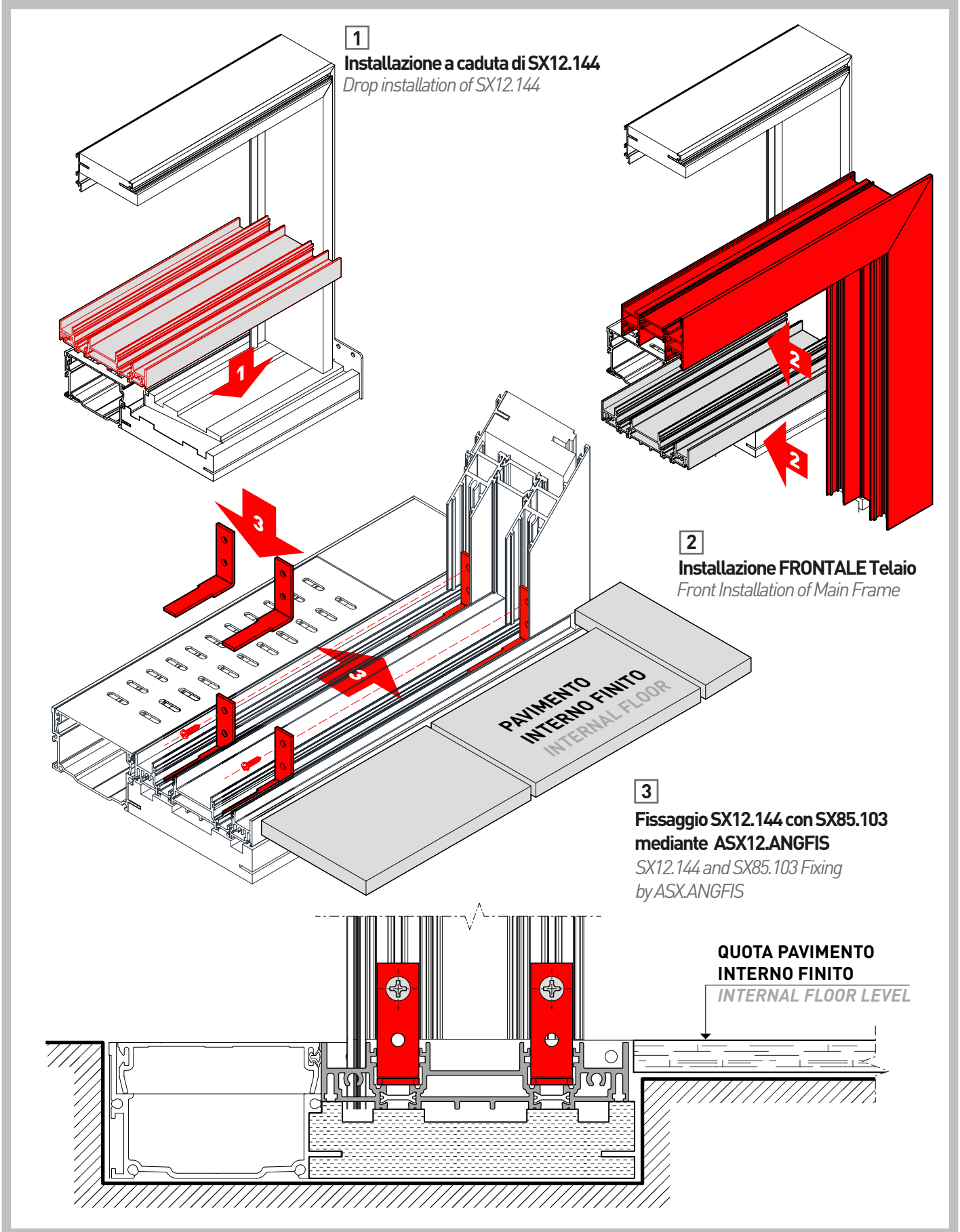



■ **PROCESSO DI MONTAGGIO**
► **ASSEMBLING PROCESS**

Posizionamento Binario INOX SX85.505
Placing INOX Rail SX85.505

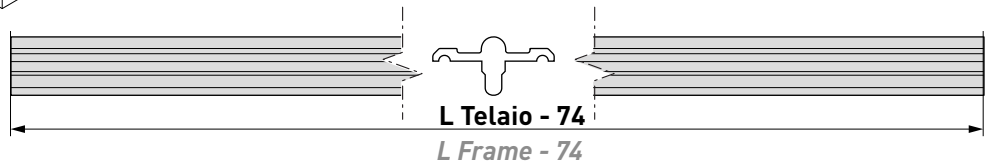
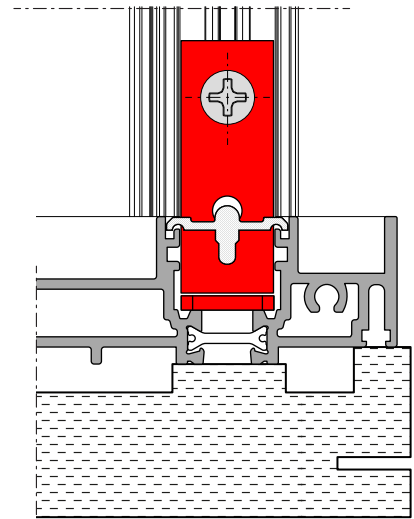
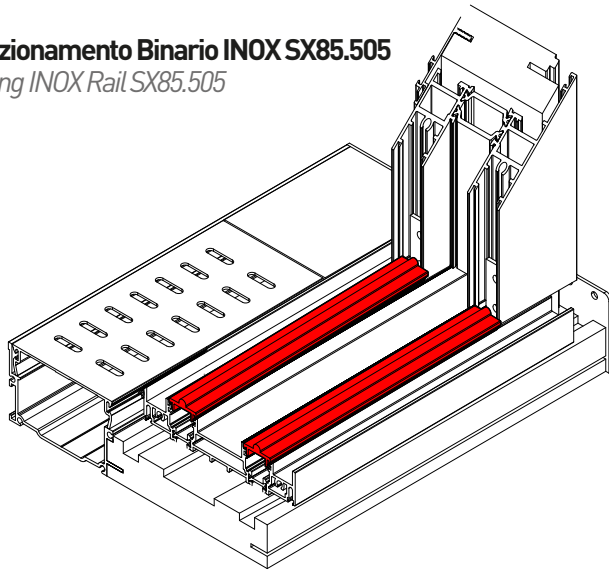

Posizionamento BX09
Placing BX09

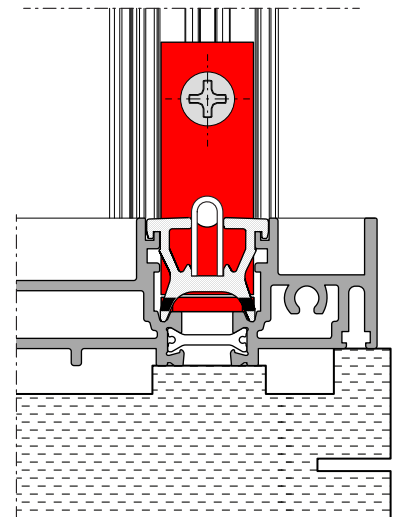
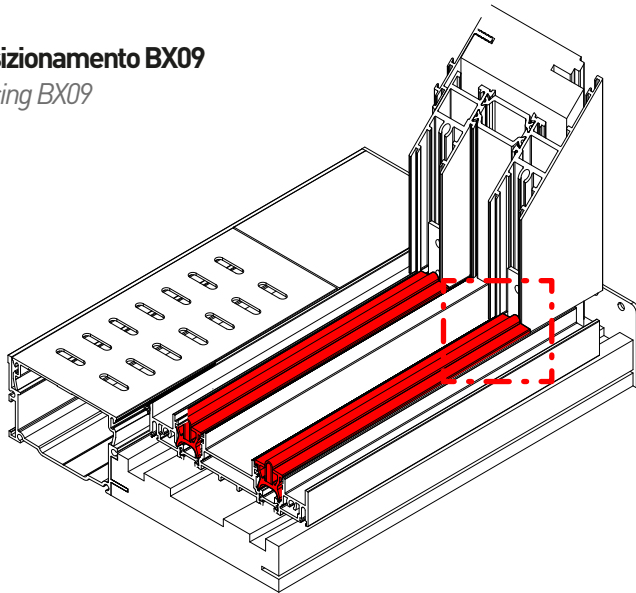

Lavorazione BX09
Tooling BX09

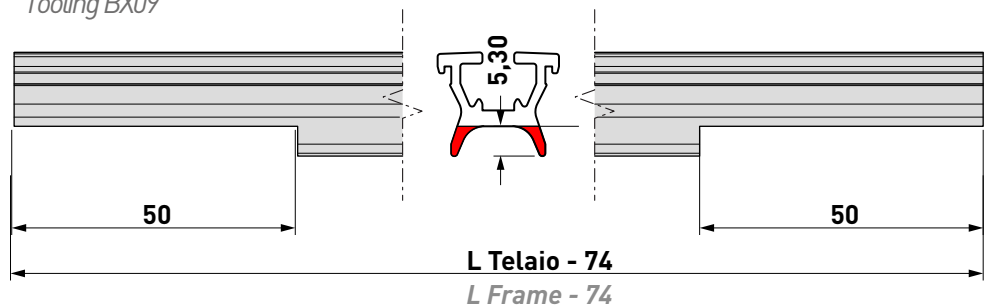
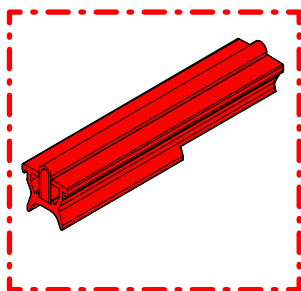



■ **DETTAGLI DI LAVORAZIONE**
► **PROCESSING DETAILS**

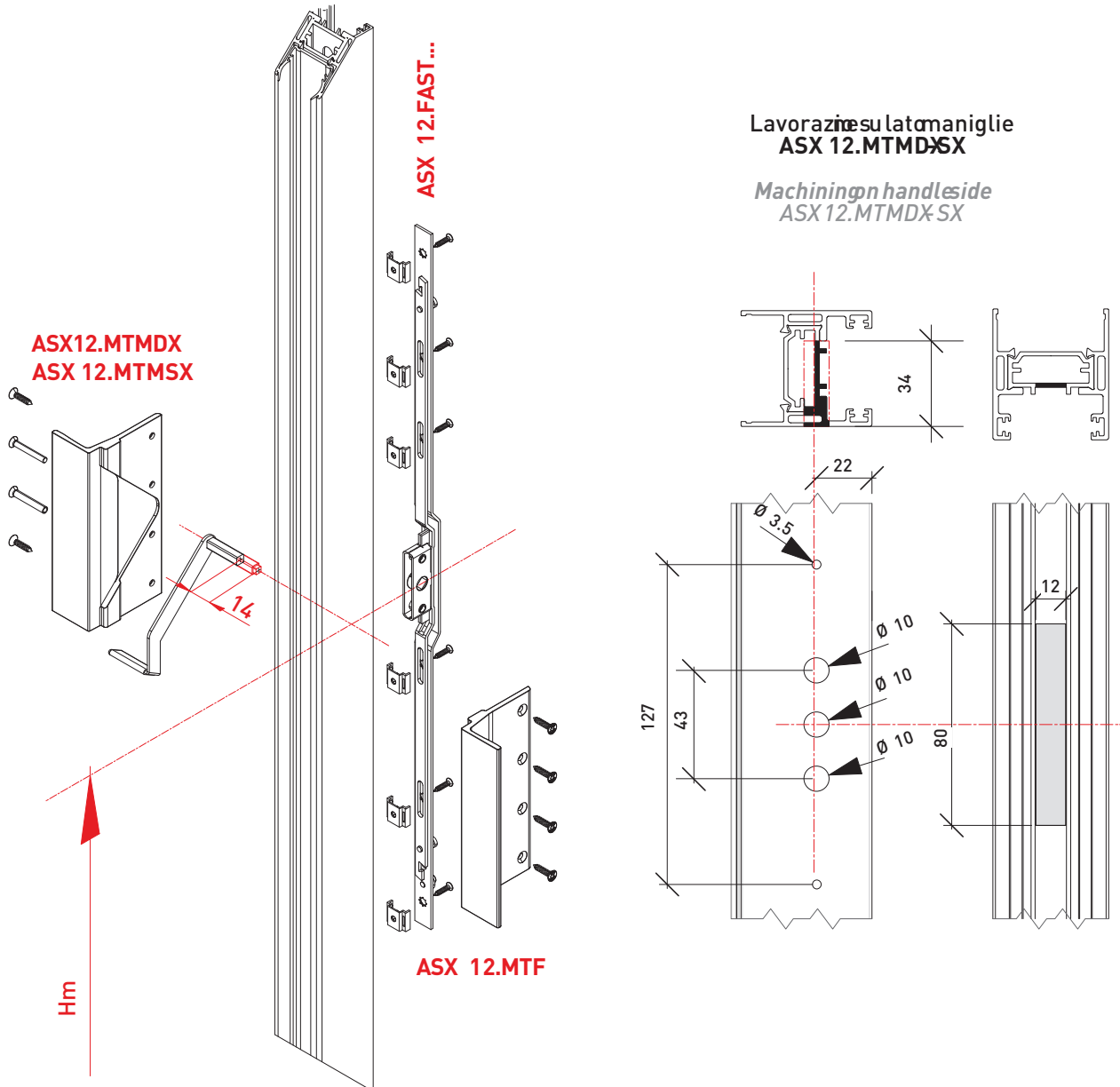

SCHEMA DRENAGGIO - Finestra 2 ante
DRAINAGE SCHEME - Window 2 sash

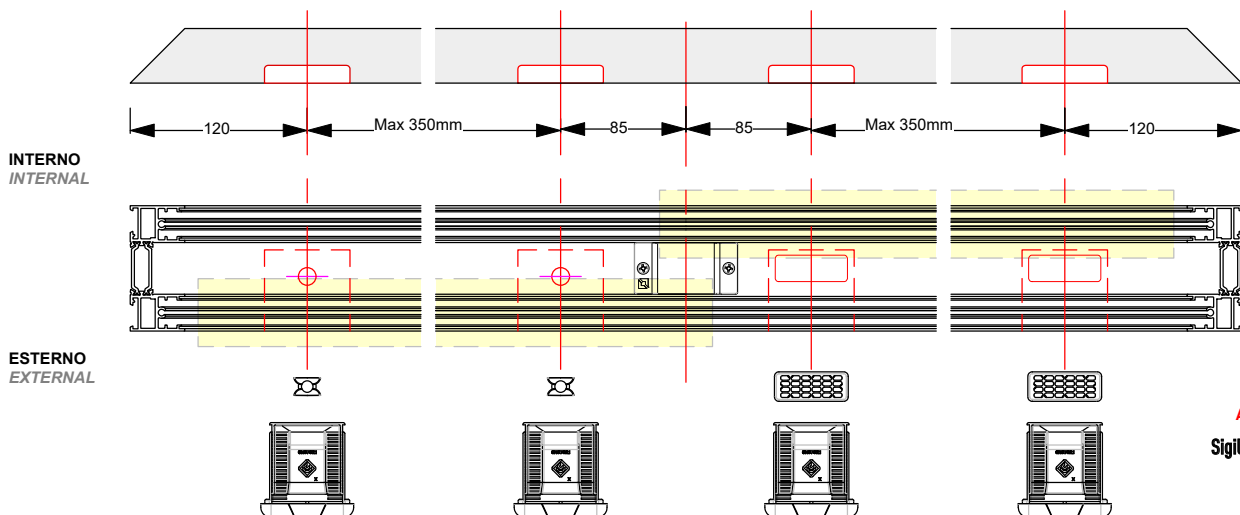
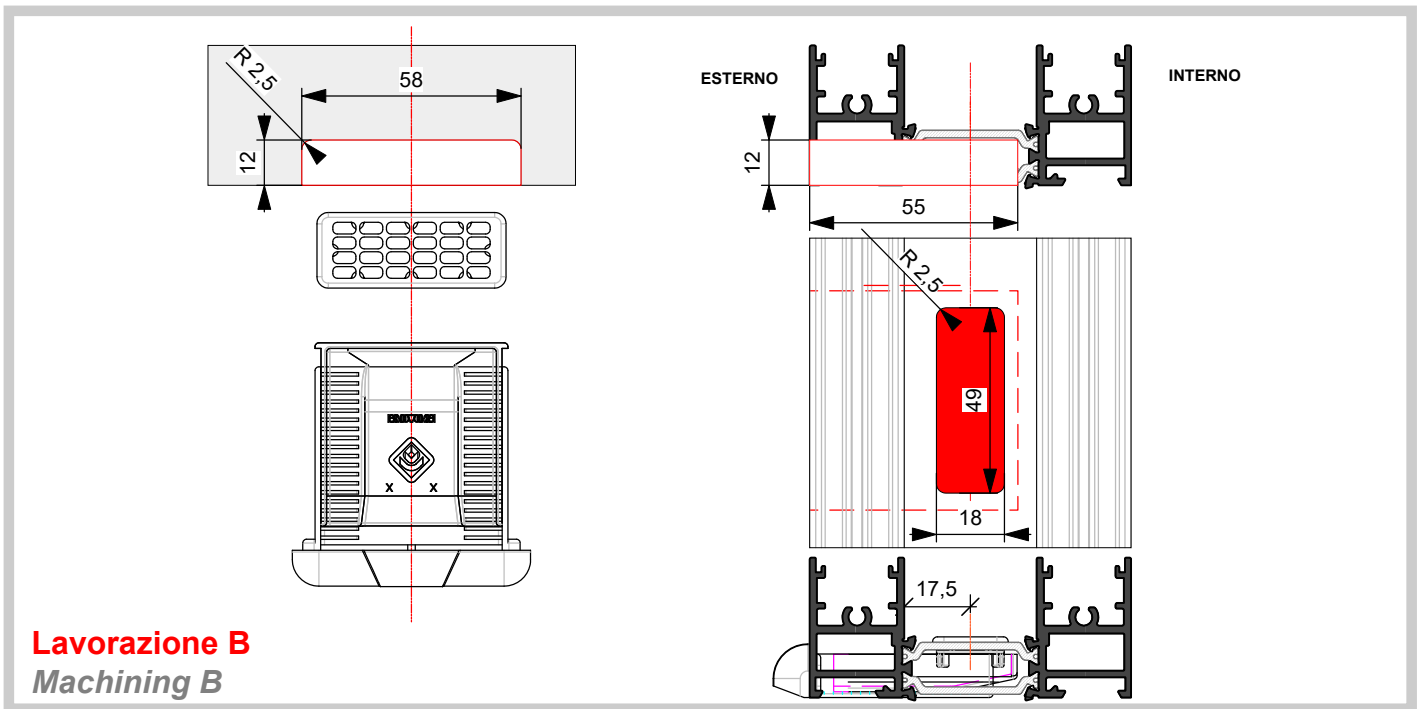
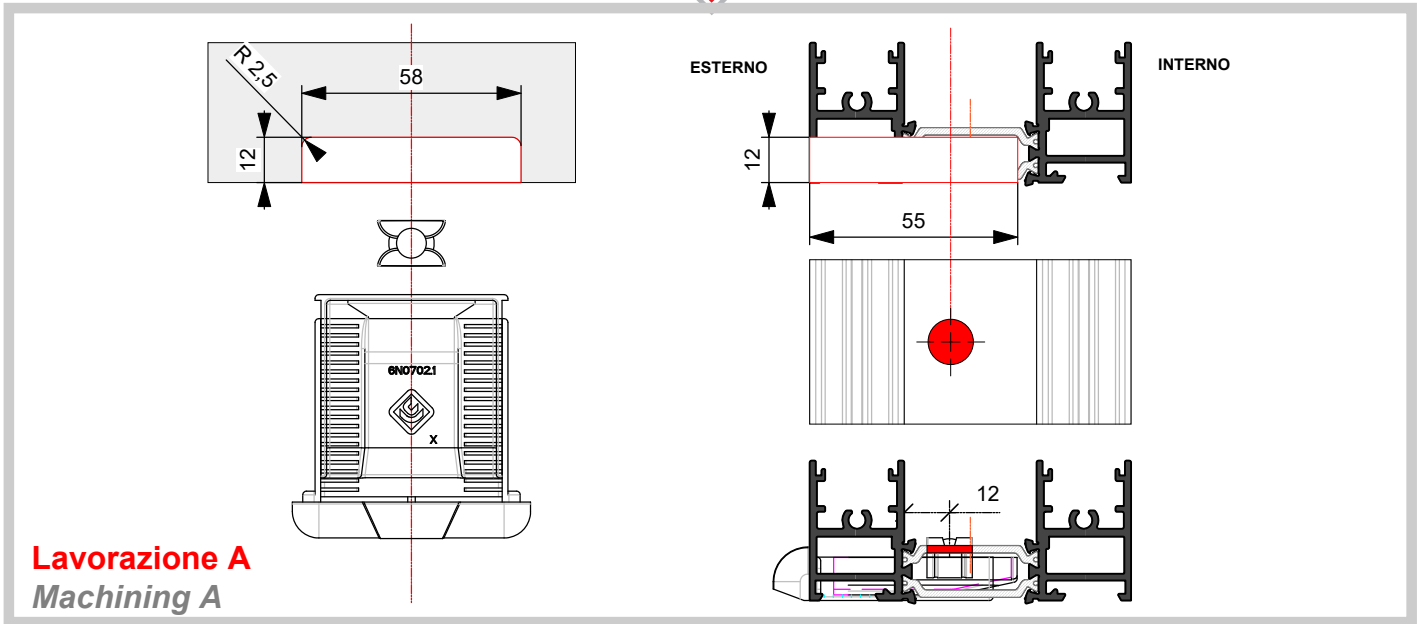

SCHEMA DRENAGGIO - Finestra 4 ante
DRAINAGE SCHEME - Window 4 sash

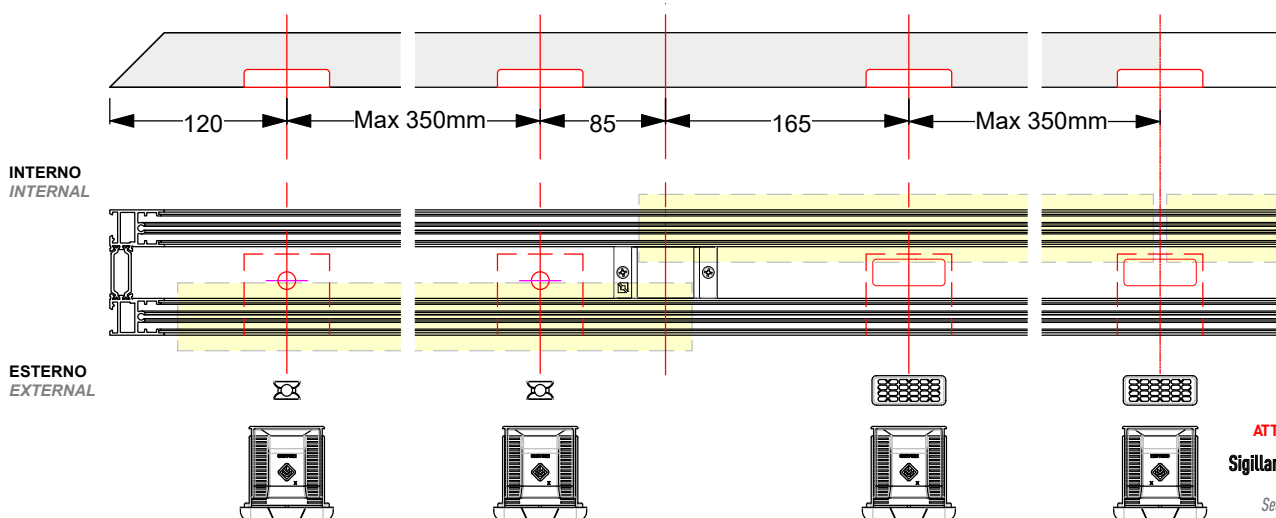
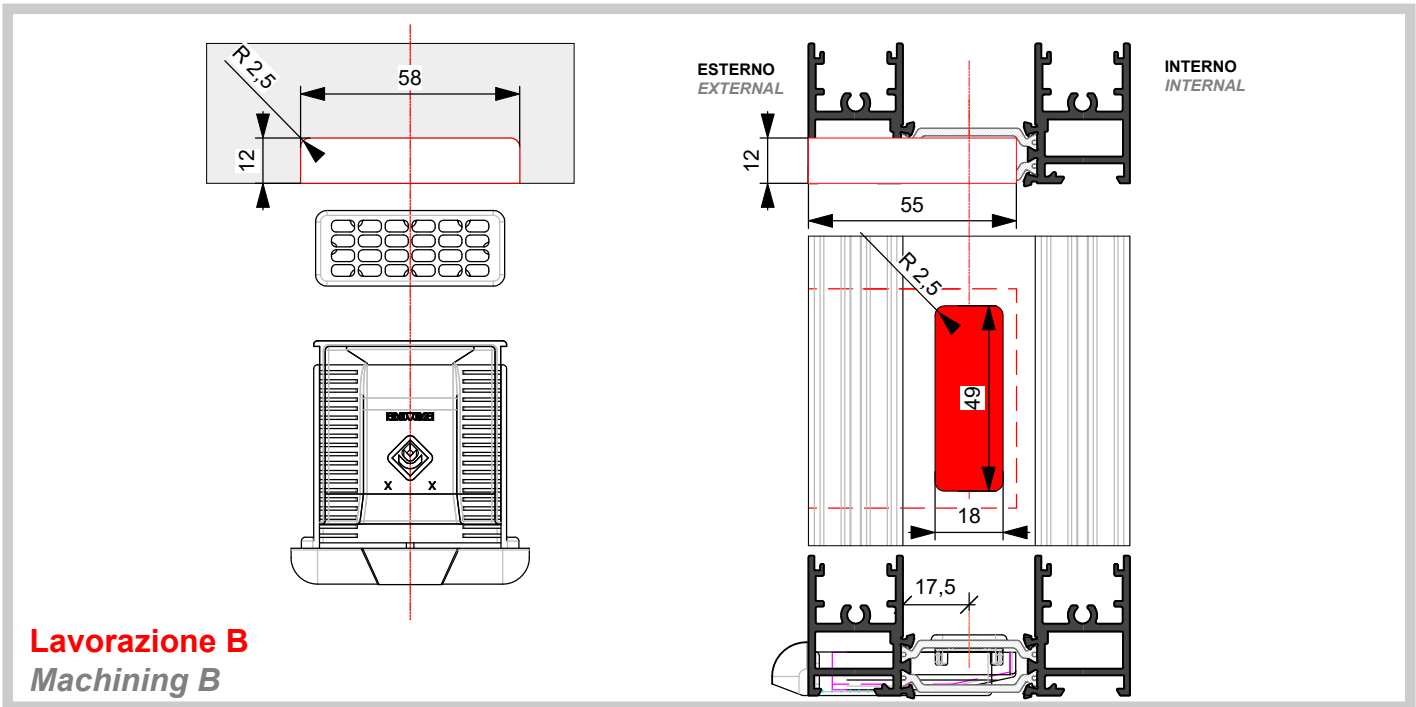
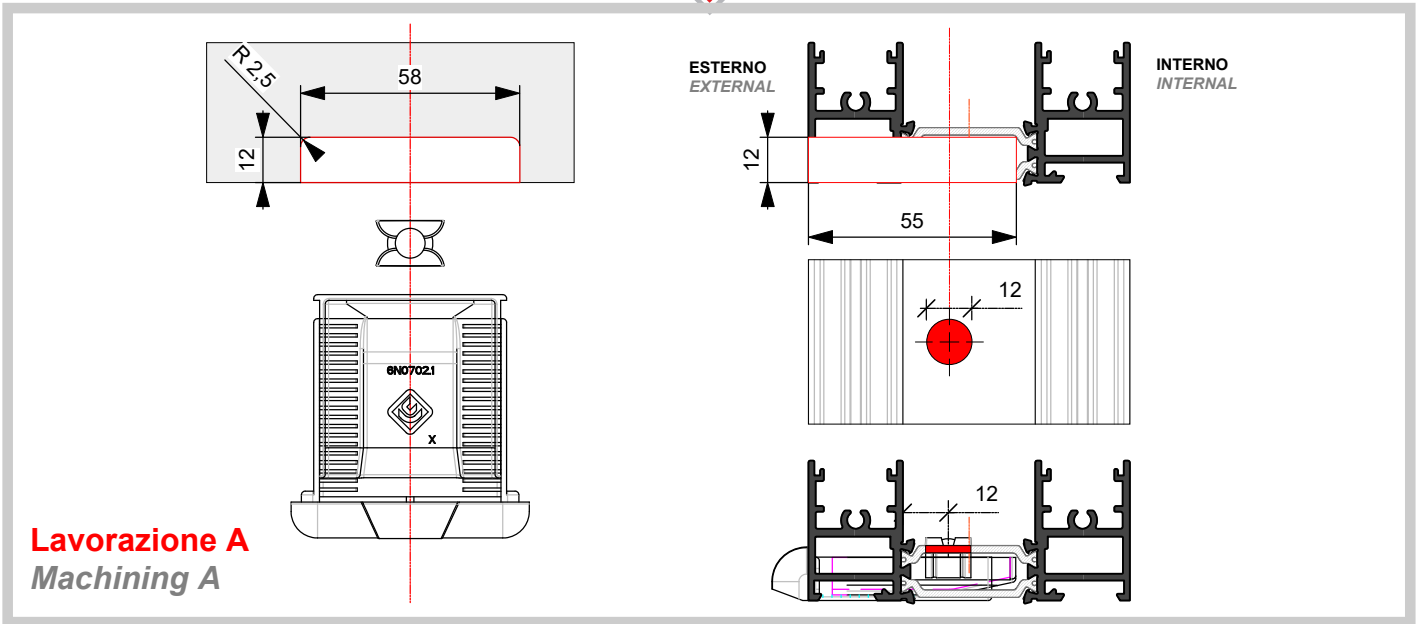

ATTENZIONE | ATTENTION
Sigillare intorno alla lavorazione
Sealing around processing

SCHEMA DRENAGGIO - Finestra 3 ante
DRAINAGE SCHEME - Window 3 sash

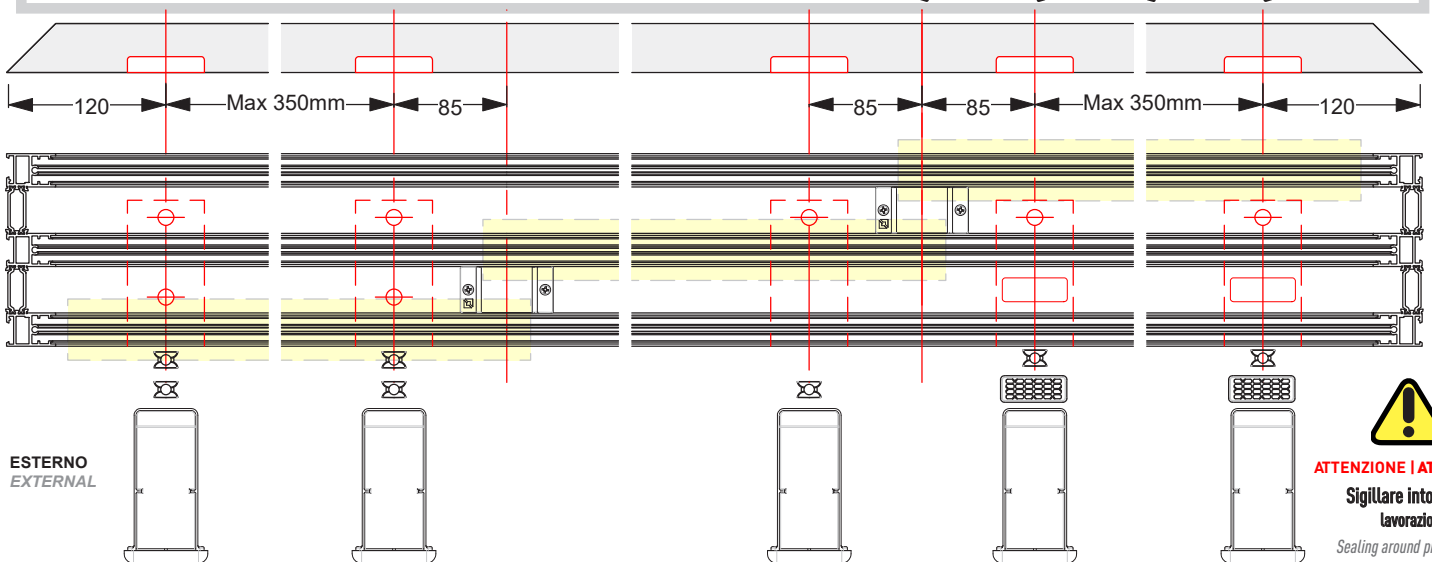
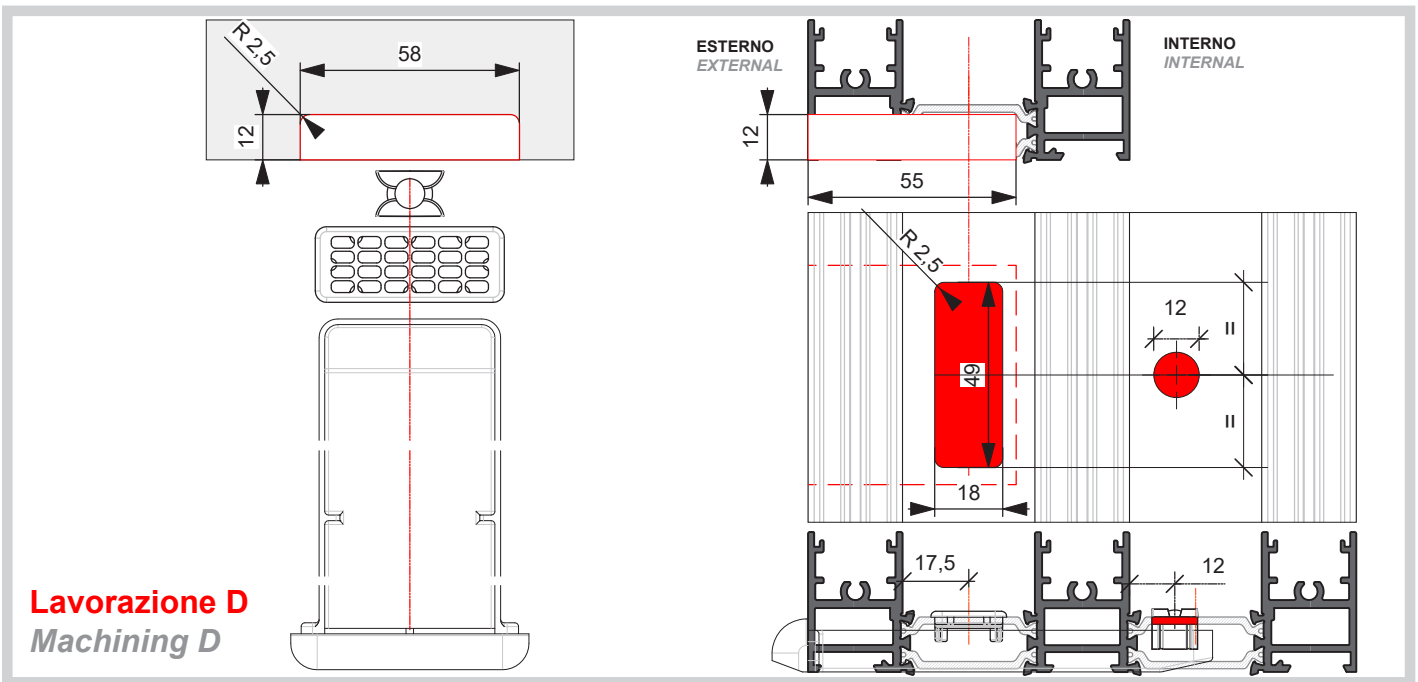
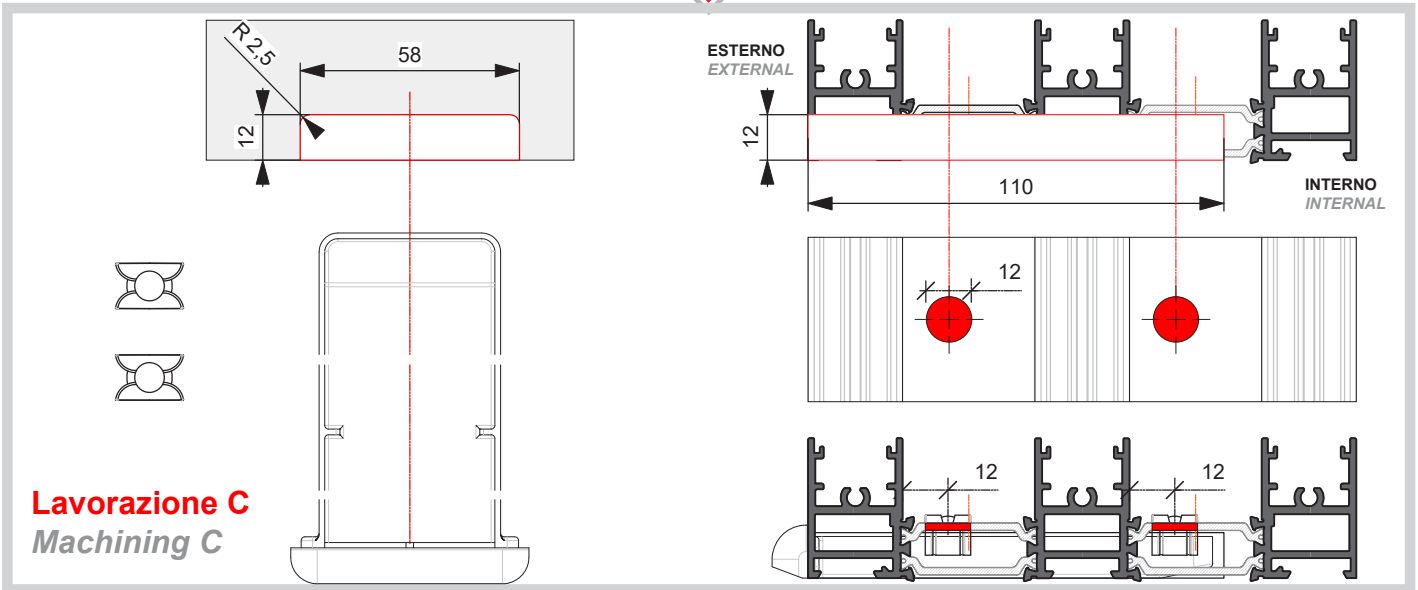



■ **DETTAGLI DI LAVORAZIONE**

► **PROCESSING DETAILS**

ACX 04.63

Clip per Profili XX70.503 | XX70.504

Clip for Profiles XX70.503 | XX70.504

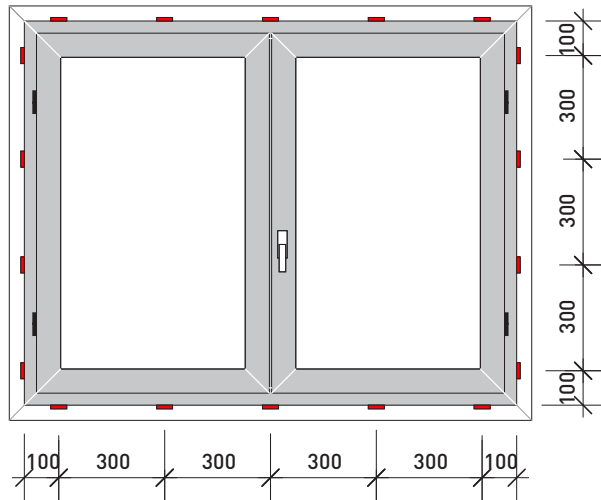
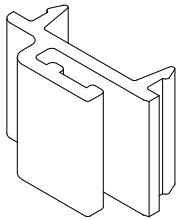

NB: Applicare le CLIPS secondo lo schema indicato quando possibile

NB: *When possible, apply the CLIPS according to the present scheme*

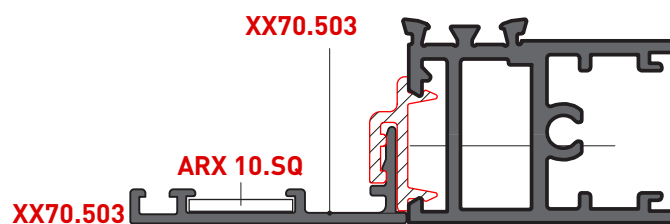
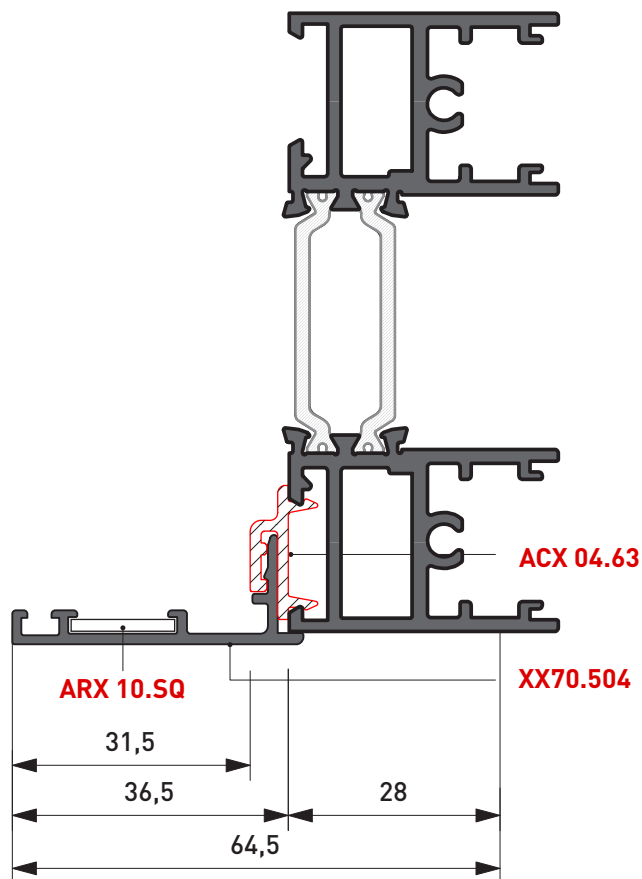



Lavorazioni Alzante AS200
Processing for LIFT & SLIDE **AS200**

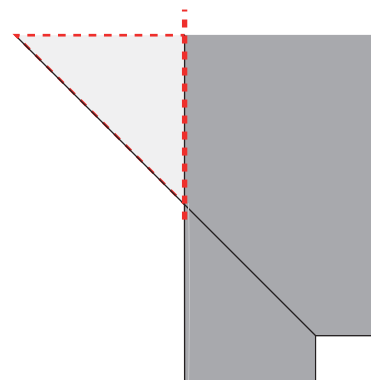
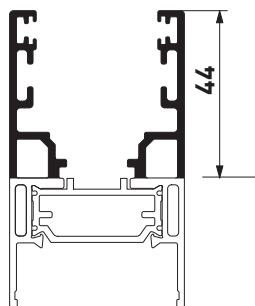
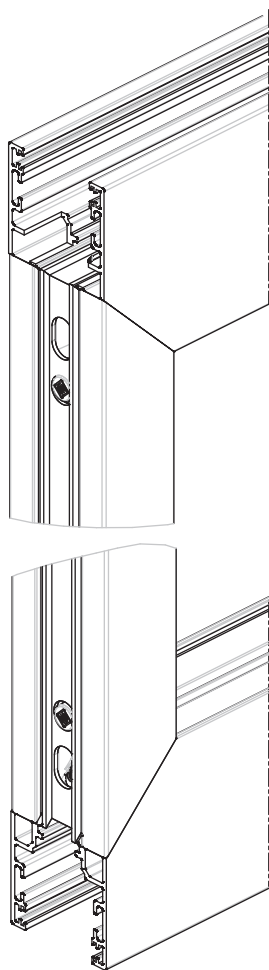

Lavorazione per montaggio profilo centrale
Machining for center profile assembly

SX85.204

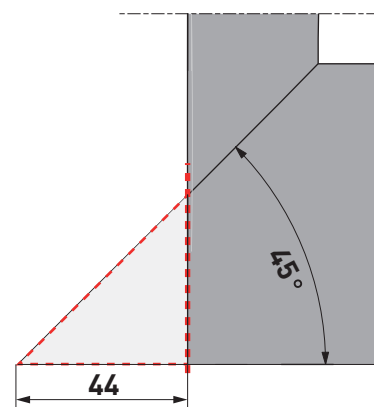
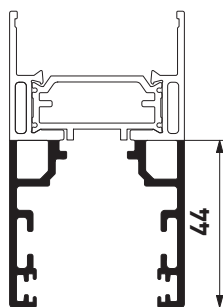

Lavorazione SX85.204 per Montaggio Tappo Copri-Lavorazione
SX85.204 Machining for Cover Cap Assembly

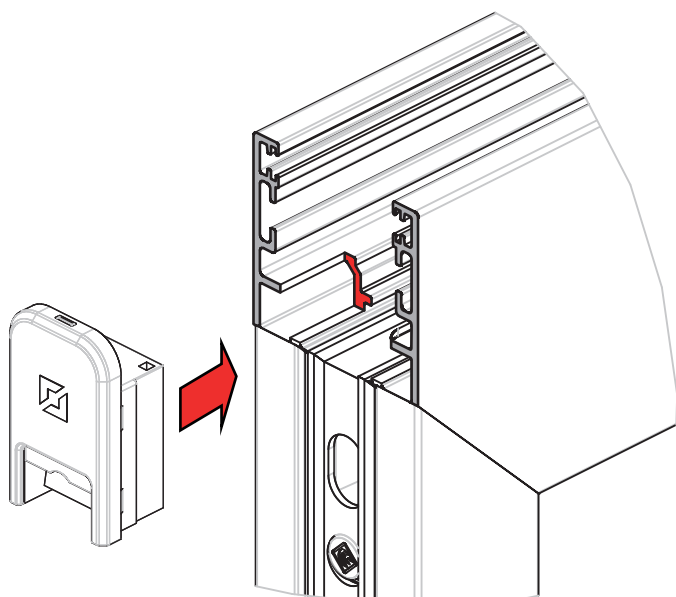

Vista Superiore Plan View

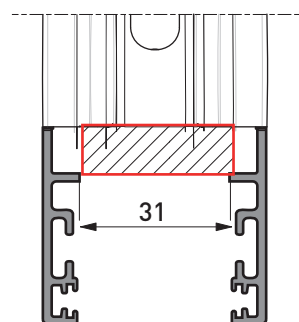
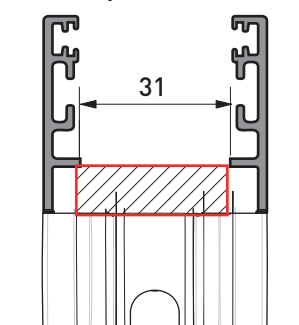

Vista Frontale Front View

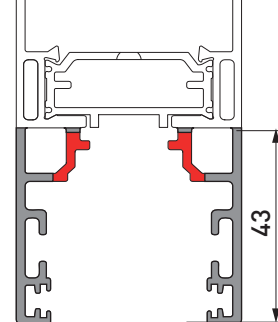
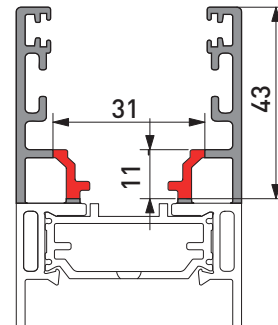



► **INSTALLAZIONE CARRELLI: LAVORAZIONI**

► TROLLEY INSTALLATION: TOOLING

VERSIONE ALZANTE
LIFTING VERSION

ASX85.CARALZ

Asola per inserimento carrelli su ante maggiorate tipo **SX12.204**
Slot for inserting trolleys on oversized doors type **SX12.204**

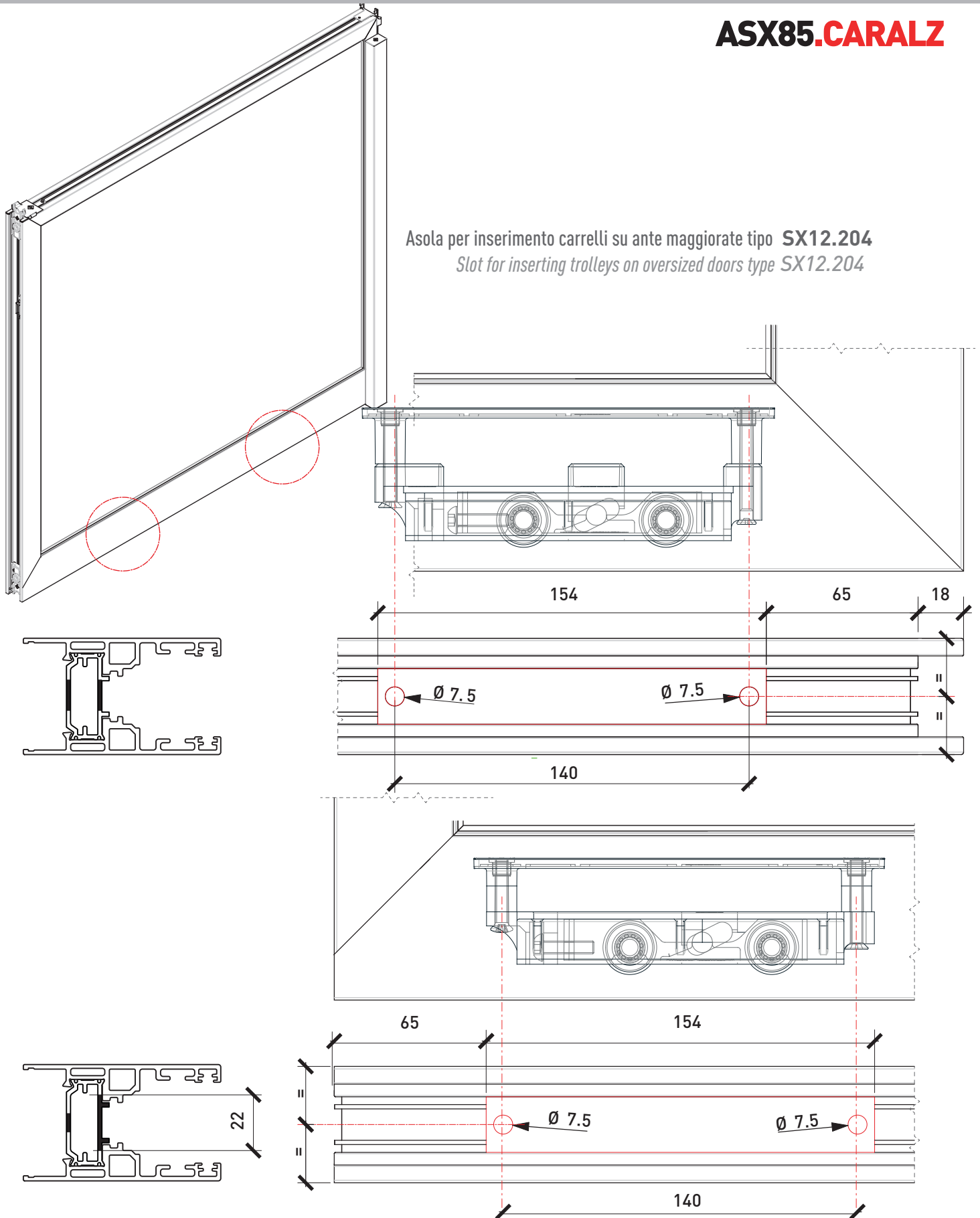



► **MONTAGGIO CARTER SX85.501 SU SX85.201**

► ASSEMBLING CARTER SX85.501 ON SX85.201

u 3 ANTE SU 2 BINARI

► 3 SASHES ON 2 RAILS

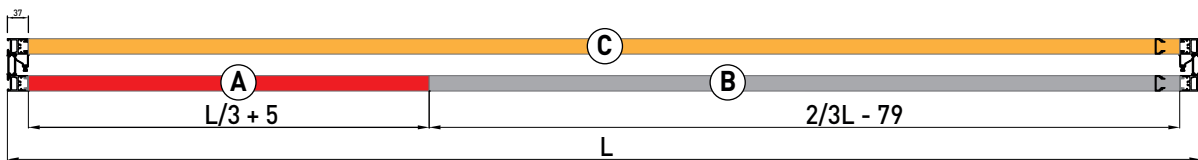
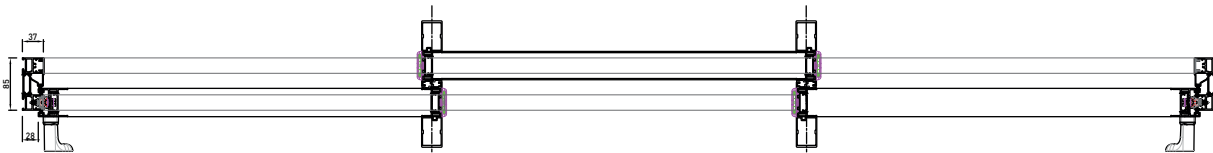
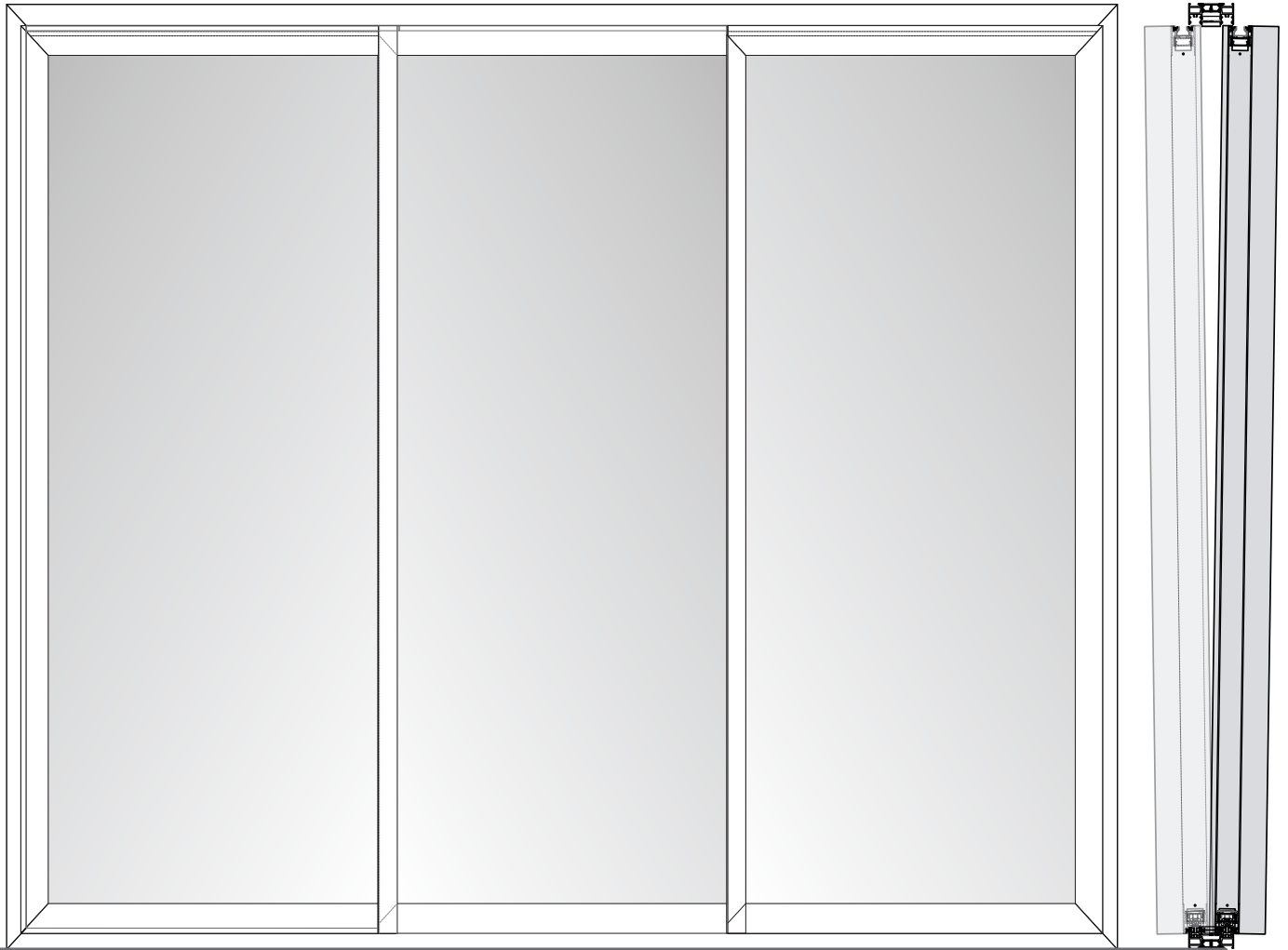

SX85.501		Adattatore orizzontale superiore	A $L/3 + 5$		1
			B $2/3L - 79$		1
			C $L-74$		1



► **MONTAGGIO CARTER SX85.501 SU SX85.201**

► ASSEMBLING CARTER SX85.501 ON SX85.201

► **3 ANTE SU 3 BINARI**

► 3 SASHES ON 3 RAILS

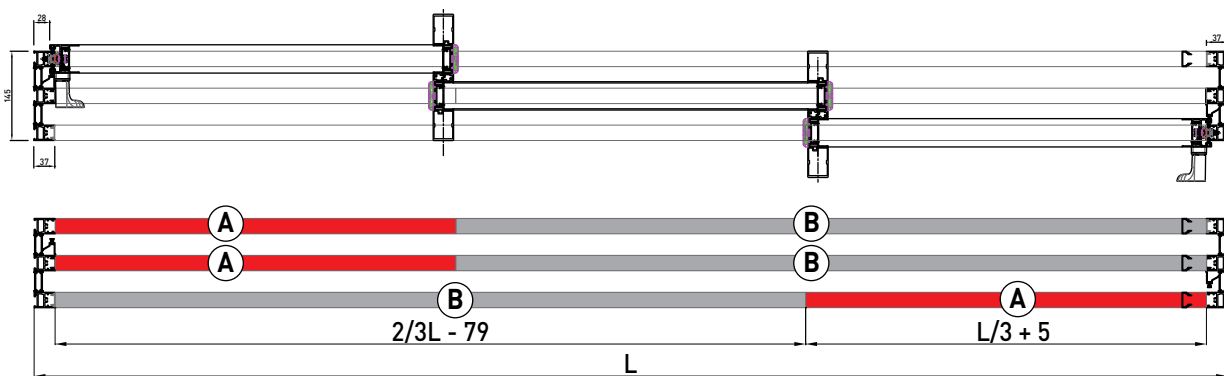
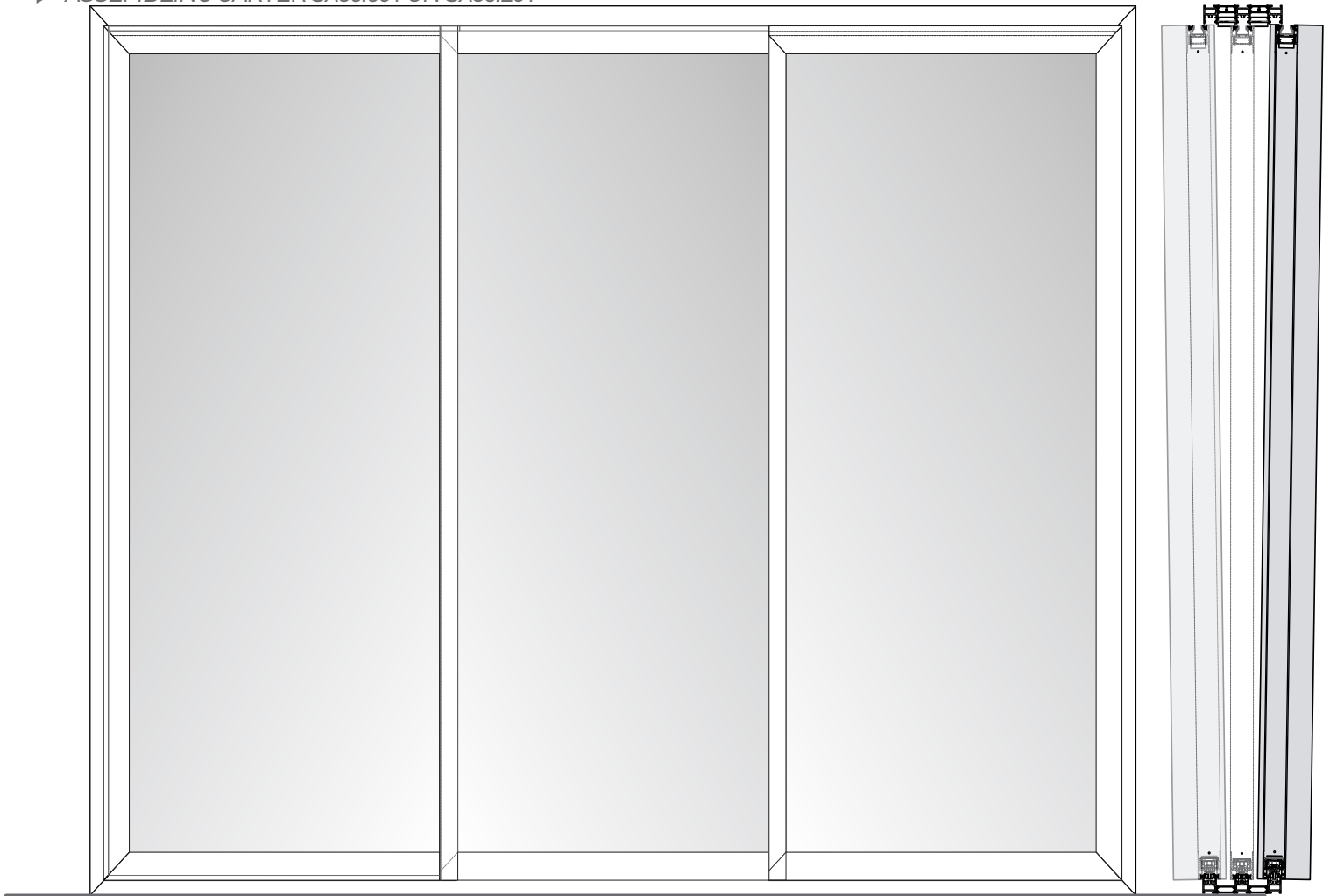

SX85.501		Adattatore orizzontale superiore	Ⓐ ■ $L/3 + 5$	<input type="text"/>	3
			Ⓑ ■ $2/3L - 79$	<input type="text"/>	3

► **MONTAGGIO CARTER SX85.501 SU SX85.201**

► ASSEMBLING CARTER SX85.501 ON SX85.201

► **4 ANTE SU 2 BINARI**

► 4 SASHES ON 2 RAILS

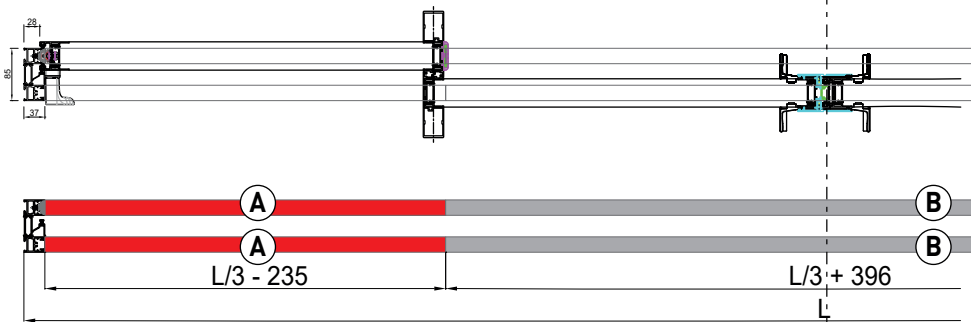
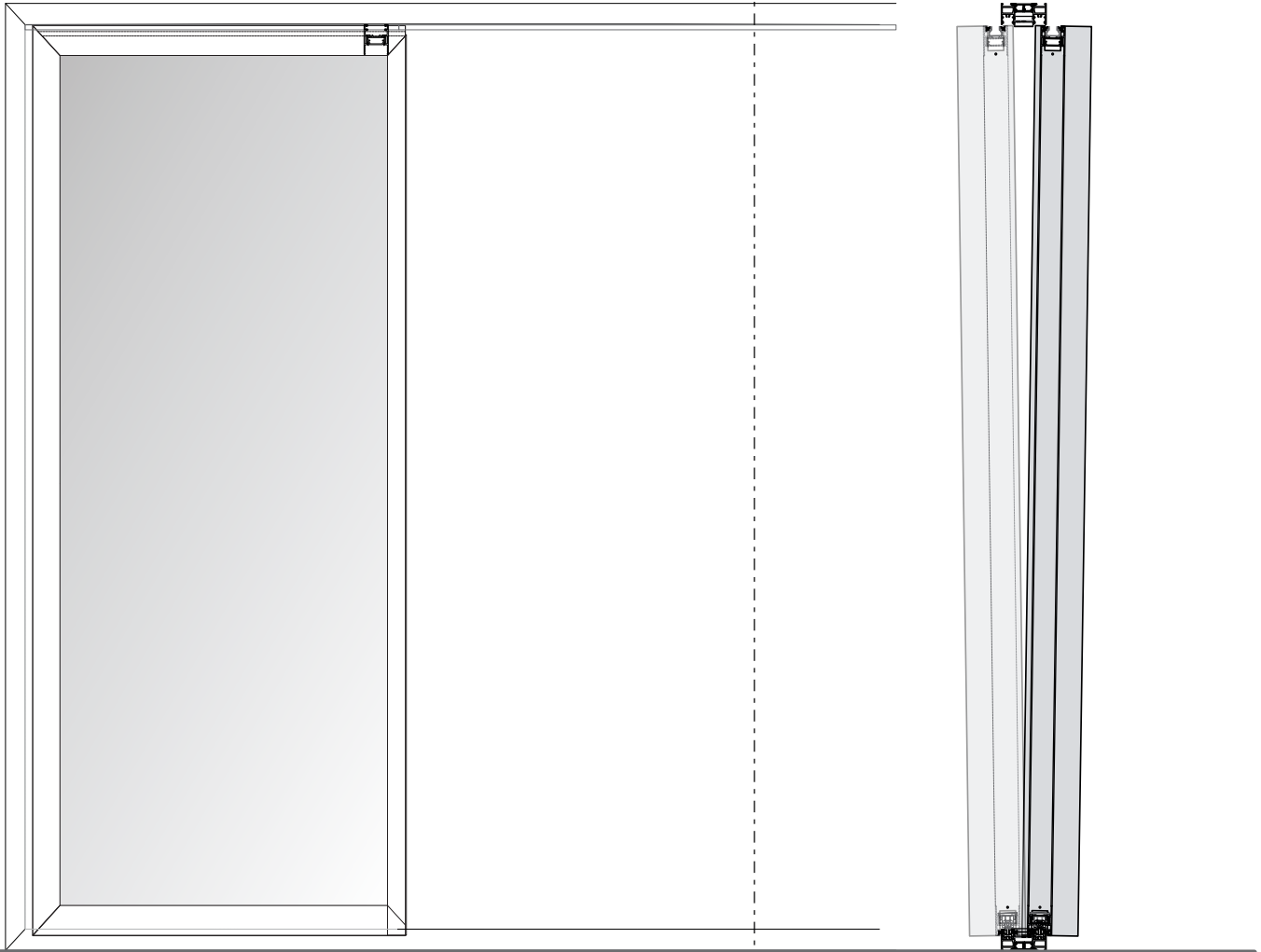

SX85.501		Adattatore orizzontale superiore	Ⓐ ■ $L/3 - 235$		4
			Ⓑ ■ $L/3 + 396$		2



► **MONTAGGIO CARTER SX85.501 SEQUENZA**

► ASSEMBLING SEQUENCE CARTER SX85.501

► **4 ANTE SU 2 BINARI**

► 4 SASHES ON 2 RAILS

(A)  L/3 - 235

(B)  L/3 + 396

1° Passaggio
1st Step



2° Passaggio
2nd Step

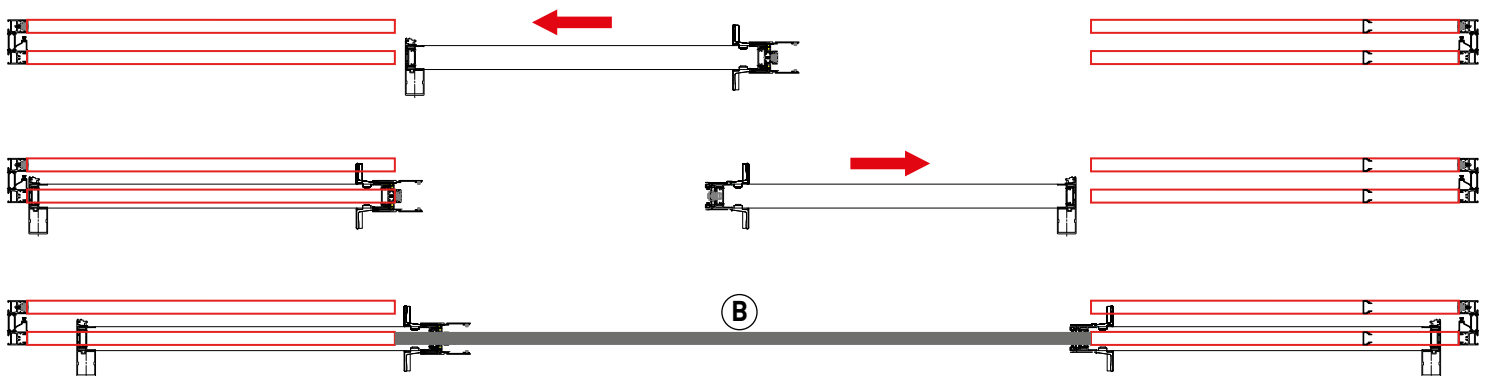

3° Passaggio
3th Step

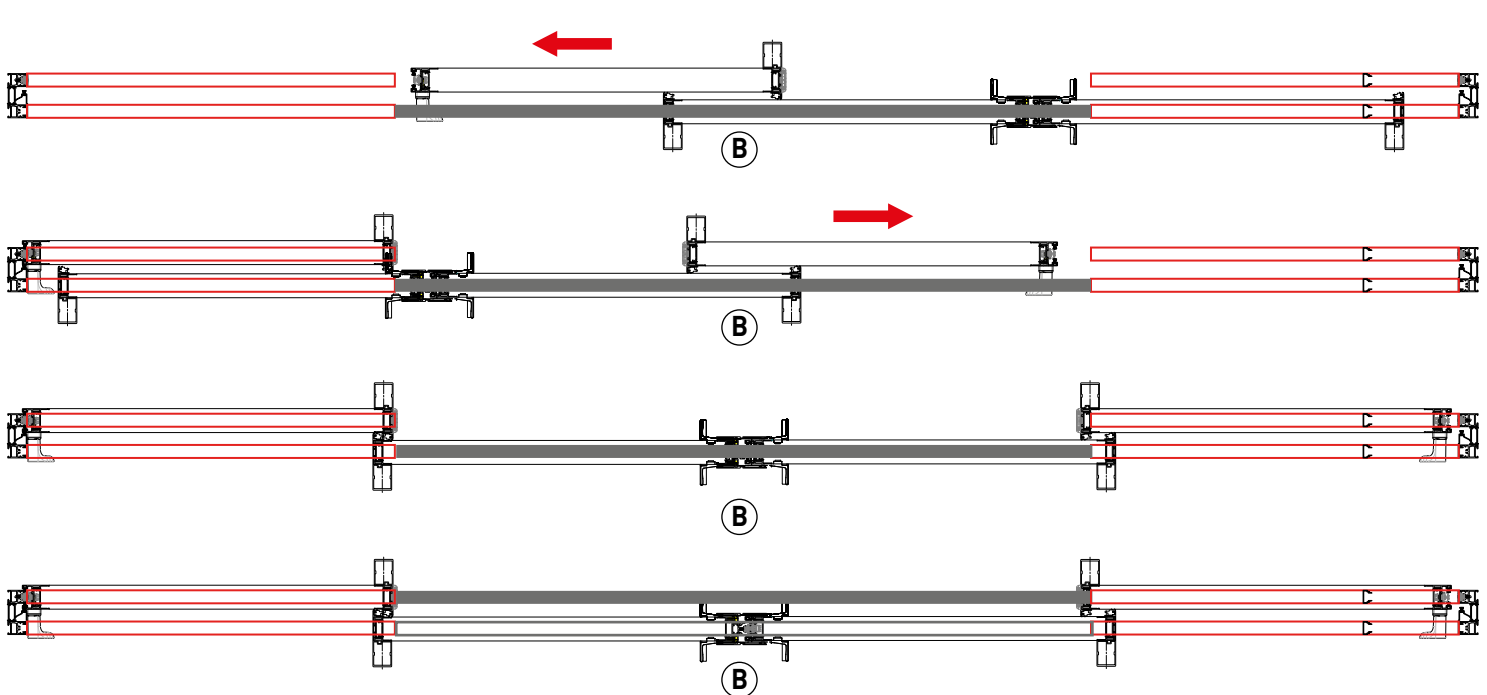

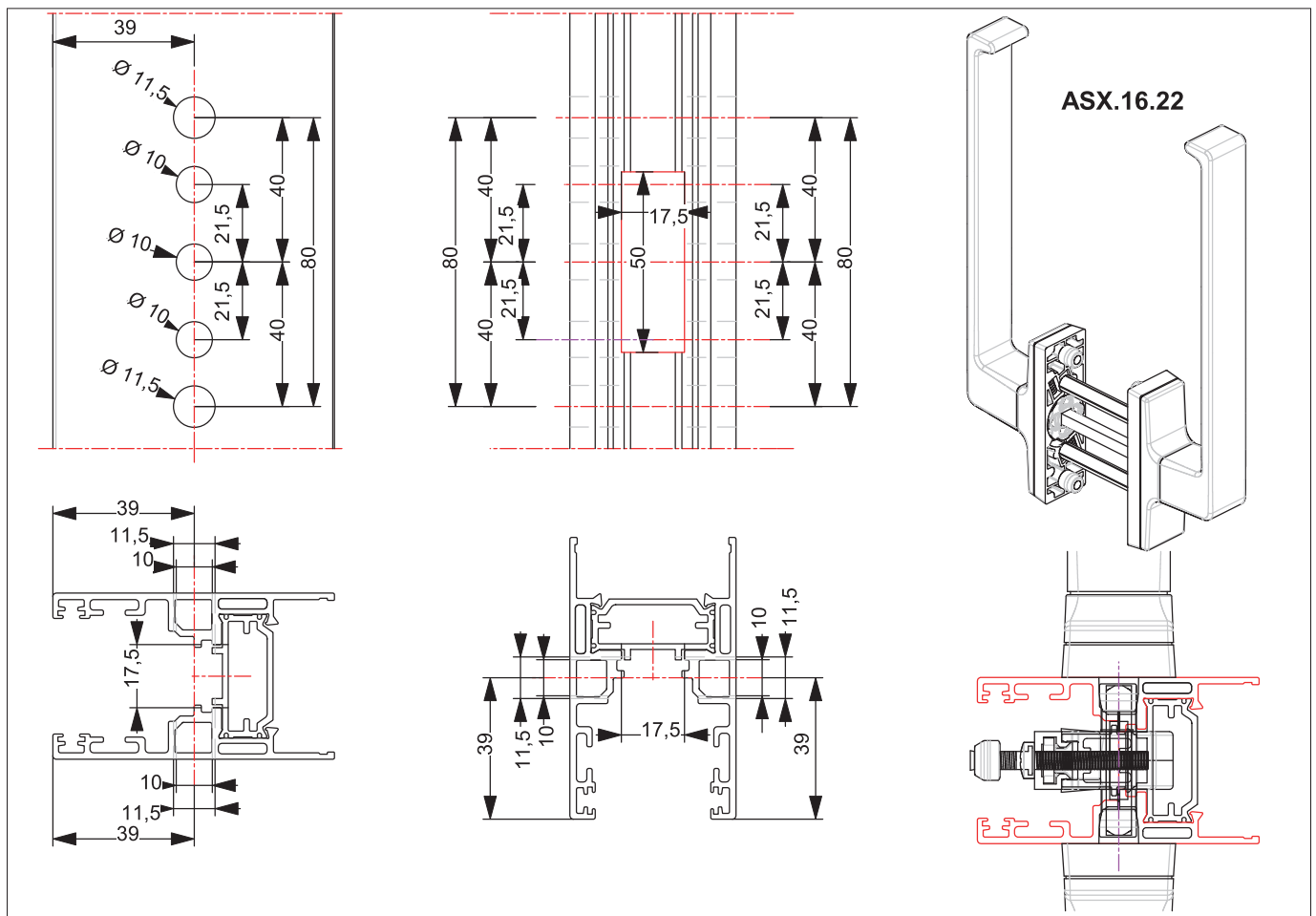
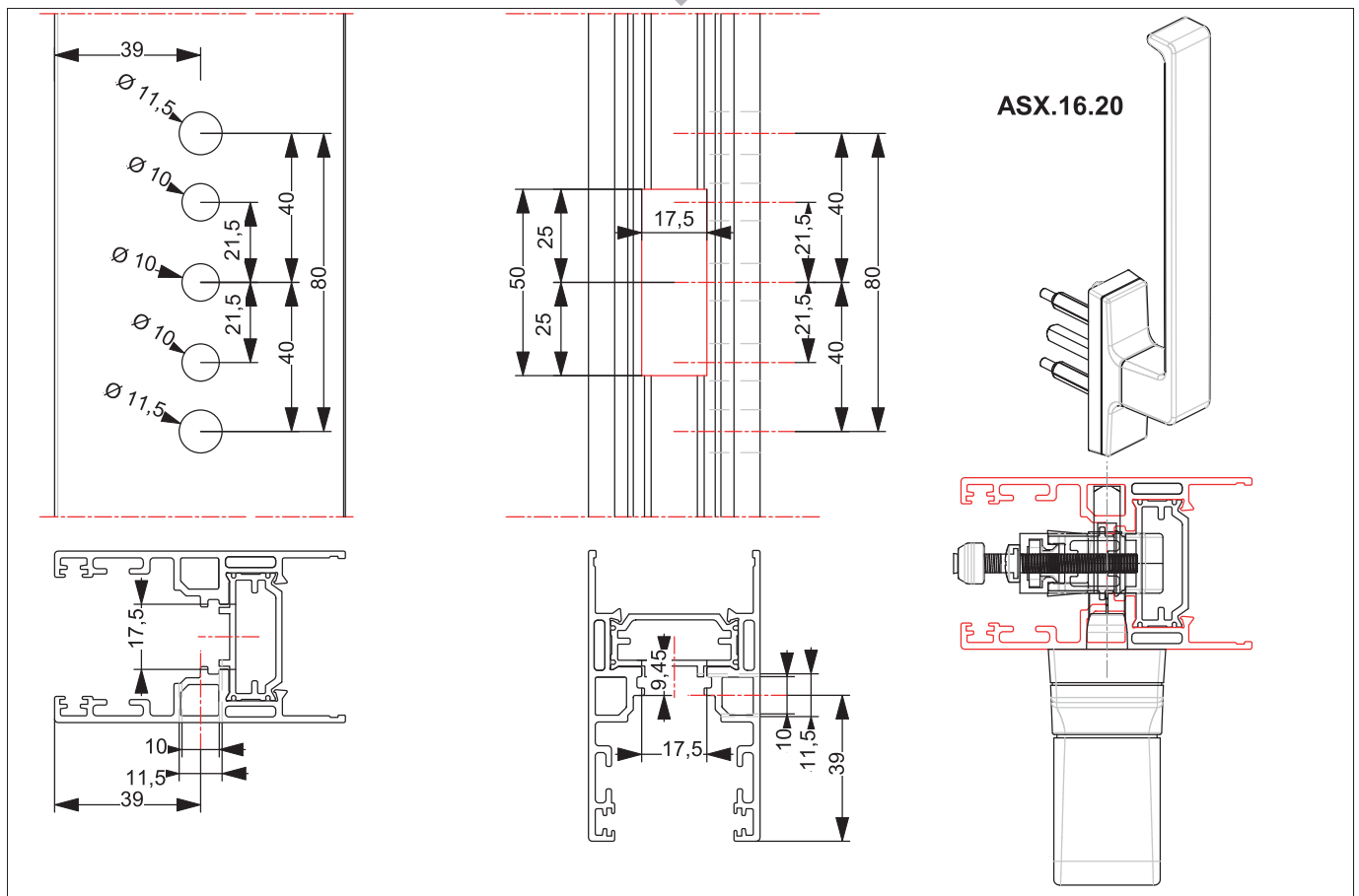



LAVORAZIONI MANIGLE SU ANTA ALZANTE SX85.204 /205 /206 /207 /208
MACHINING OF HANDLES ON LIFTING S ASH SX85.204 /205 /206 /207 /208

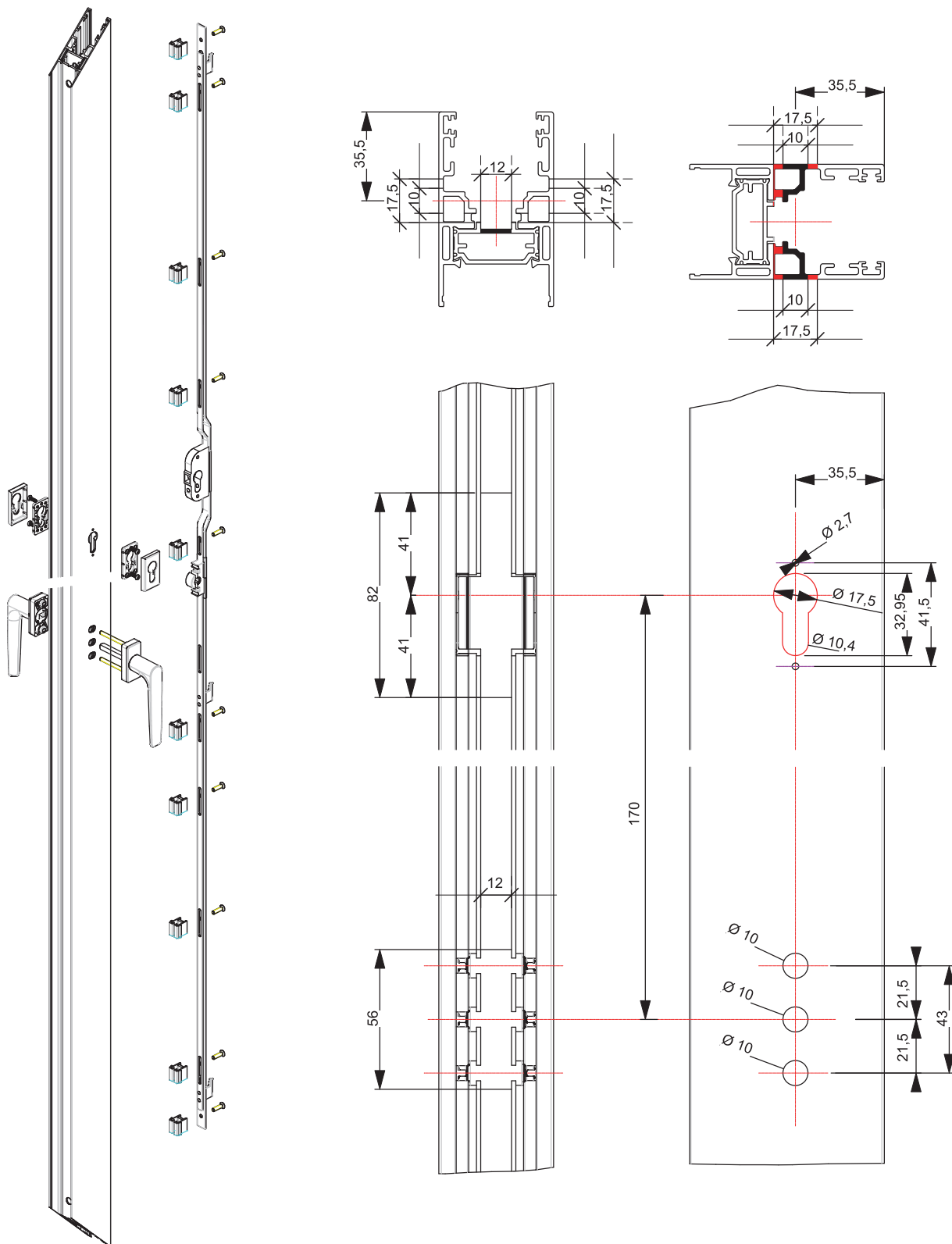

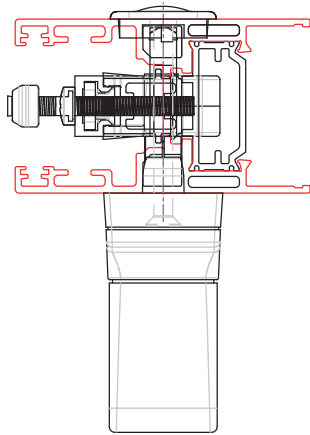

ASX.16.20

ASX.16.07

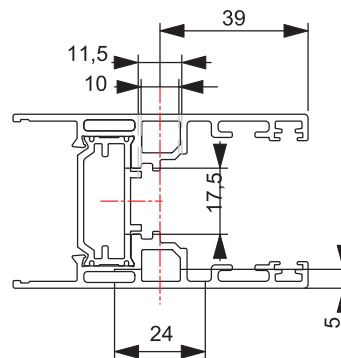
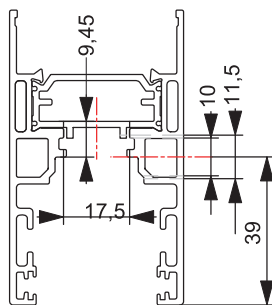
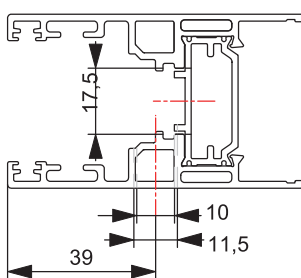
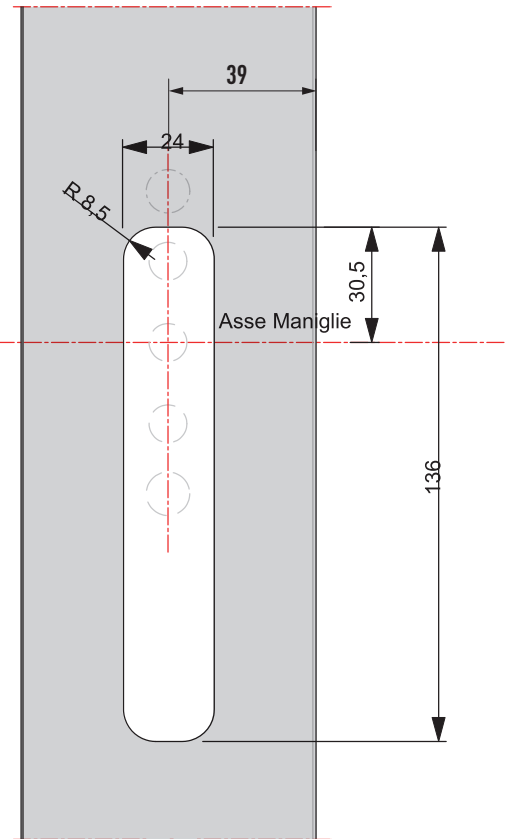
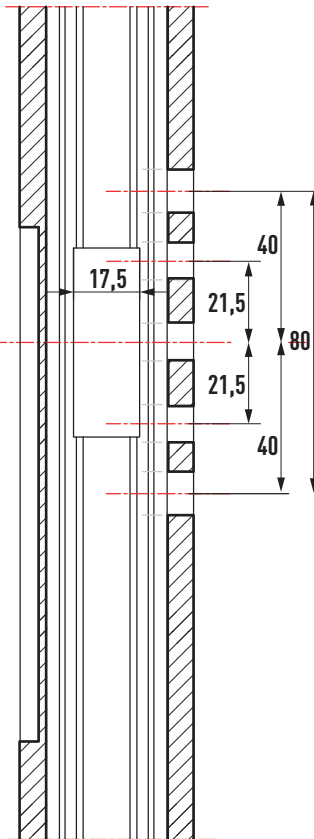
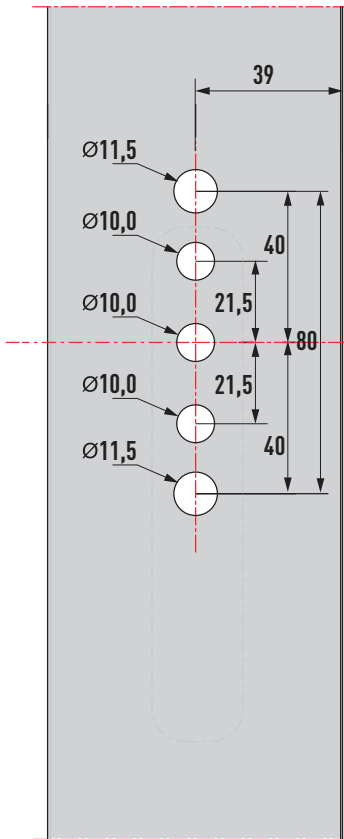
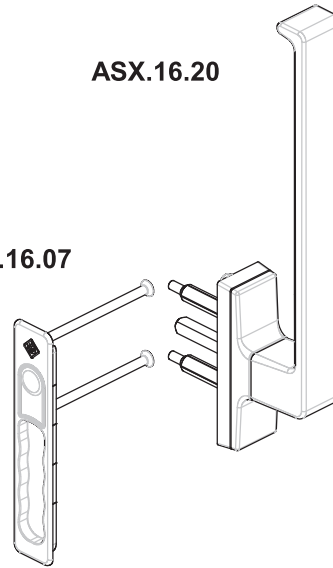



Lavorazione e montaggio **ASX.07.10** su profilo **SX11.303** per alzante AS200

Machining and assembly **ASX.07.10** on profile **SX11.303** for AS200 lifting unit

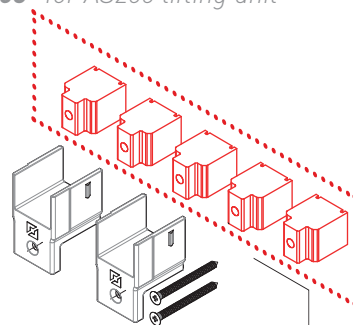
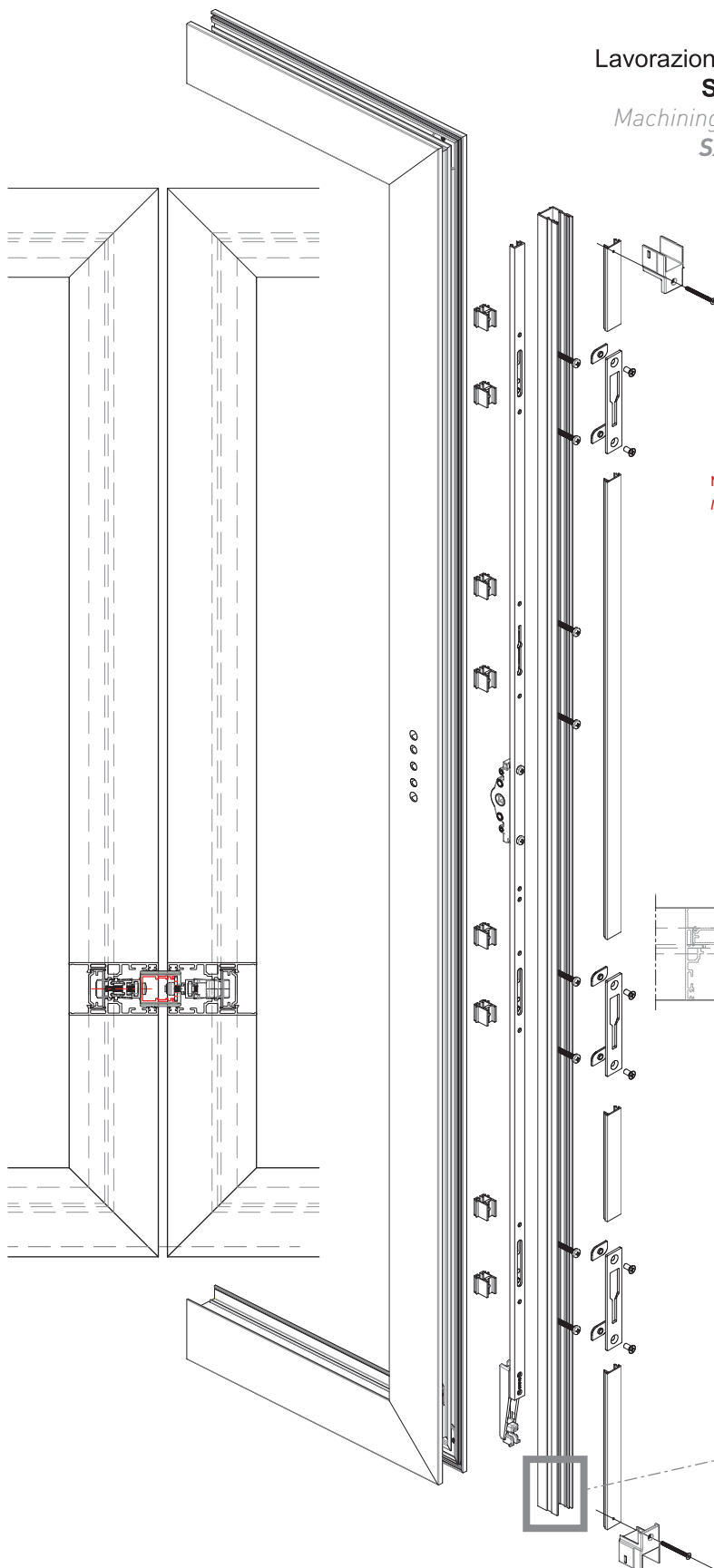

NB Elementi da non utilizzare e sostituire con Spessori dim. 12x6 [cfr. tav. D26]
NB Items not to be used and to be replaced with Spacer 12x6 mm [see tab. D26]

Posizionare l'asta multipunto e il profilo di riporto alle quote indicate e utilizzare l'asta come dima di foratura per il fissaggio sull'anta

Position the multi-point rod and the carry-over profile at the dimensions indicated and use the rod as a drilling template for fixing on the sash

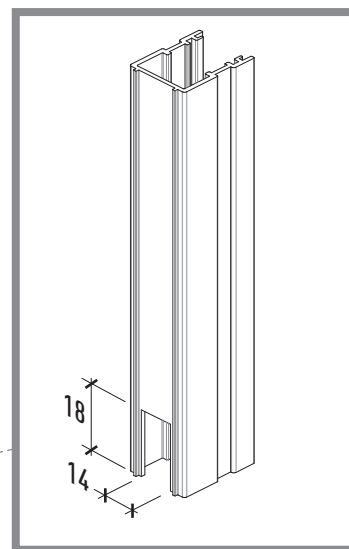
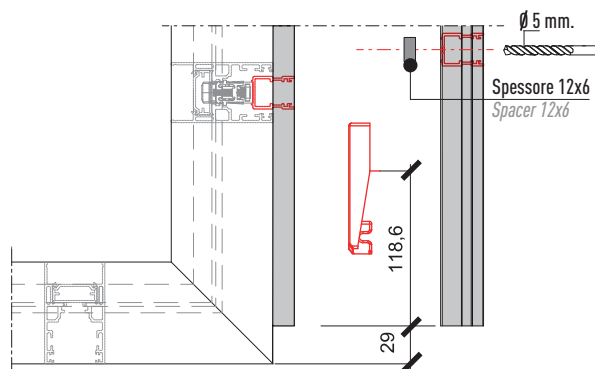



APPLICAZIONE FASTLOCK SU ANTA ALZANTE
FASTLOCK APPLICATION ON LIFTING SASH

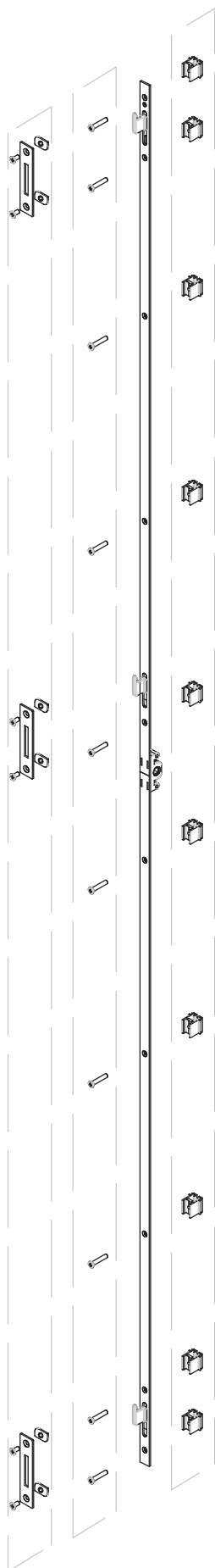

FastLock chiusura multipunto con uncini - E 15mm <i>FastLock multi-point locking with hooks - E 15mm</i>								
Asta <i>Locking</i>		L	E	H maniglia <i>H handle</i> Min	H anta <i>H sash</i> Min	Kit chiusure <i>Locking kit</i>		
Codice <i>Code</i>	Q.tà							
ASX.13.02	1	600	15	400	800	ASX.85.07		
ASX.13.03	1	1000		600	1200			
ASX.13.04	1	1800		1000	2000			

Kit Riscontri <i>Fastlock kit</i>					
Articoli					L
Codice <i>Code</i>	Q.tà				
ASX.85.07	1	6	6	2	600
	1	6	6	2	1000
ASX.85.08	1	10	10	3	1800

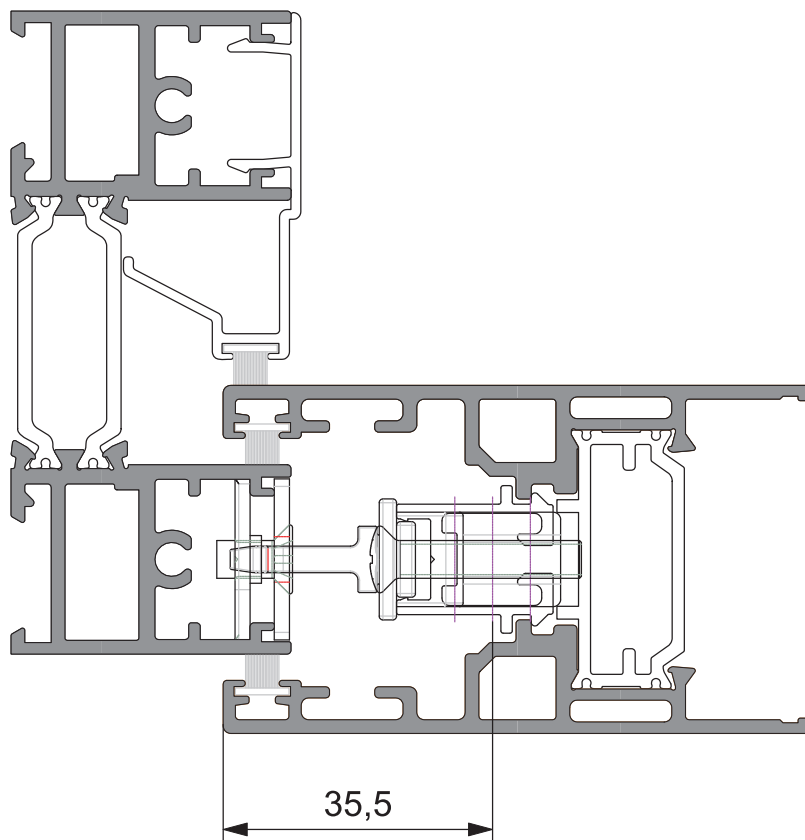



APPLICAZIONE FASTLOCK SU ANTA ALZANTE
FASTLOCK APPLICATION ON LIFTING SASH

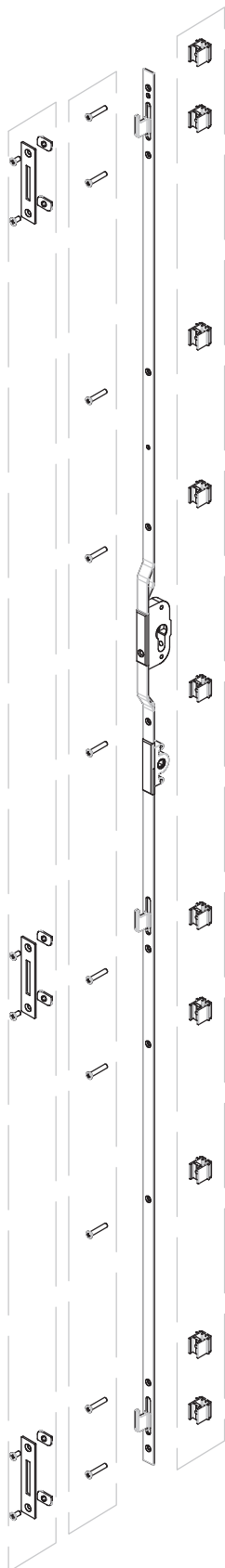

FastBlock multipunto con uncini con cilindro europeo - E 15mm

FastBlock multipoint lock with hooks - European cylinder fitting

Asta <i>Locking</i>		L	E	H maniglia <i>H handle</i> Min	H anta <i>H sash</i> Min	Kit chiusure <i>Locking kit</i>		
Codice <i>Code</i>	Q.tà							
ASX.13.05	1	1800	15	1000	2000	ASX.85.08		

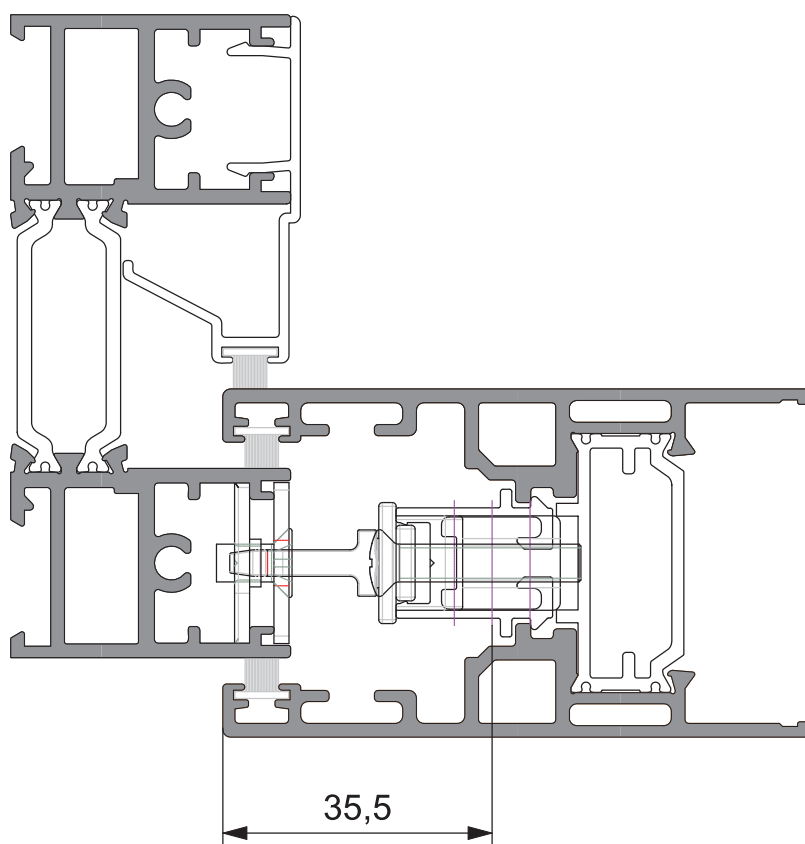

► **SCHEMA DI MONTAGGIO ALZANTE AS 200**

► **MOUNTING DIAGRAM LIFT-AND-SLIDE AS 200**

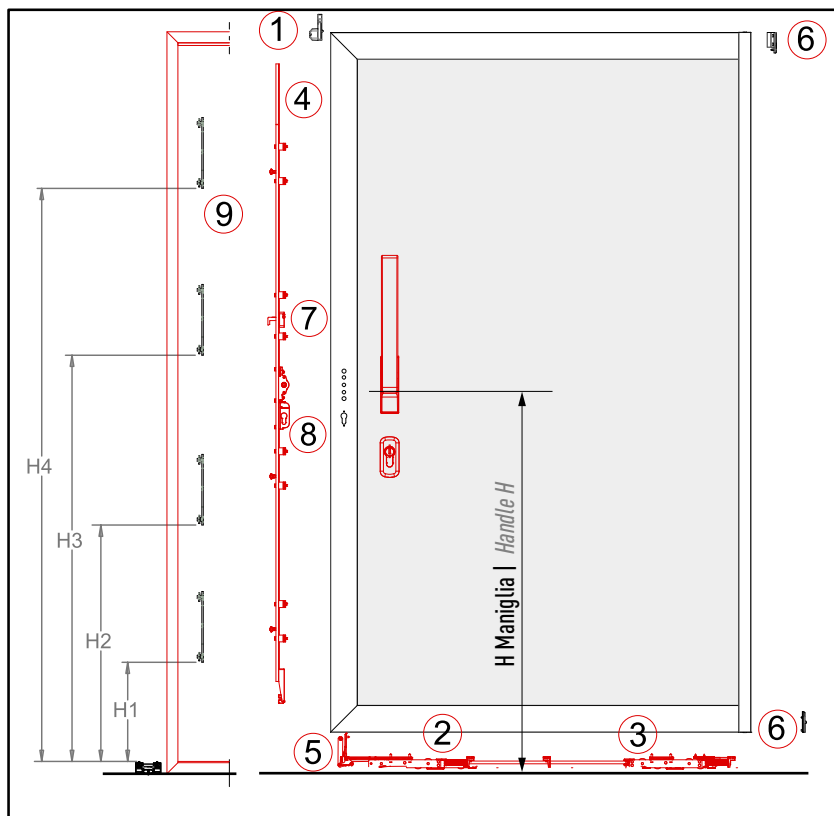

Campo di applicazione Application Field (mm)

Art.	H min	H max	LA max	HM
ASX .16.00/00R	1175	1775	1200	410
ASX .16.01/01R	1776	2275	2500	1010
ASX .16.02/01R	2276	2675	2500	1010

Posizioni Contropiastra Locking plate positioning (mm)

Art.	H1	H2	H3	H4
ASX .16.00/00R	212	548*	974	-
ASX .16.01/01R	244	688	1148*	1574
ASX .16.02/02R	244	688	1148*	1974

* Posizione della microventilazione articolo ASX .16.31

LA (anta) min. = 800 mm

LA > 1800 mm è consigliabile l'utilizzo del kit carrello supplementare
LA > 1800 mm is recommended to use the additional roller Art. ASX.16.04

Legenda / Legend Asta collegamento carrelli - L 1500mm
Connecting rod - L 1500mm

LA
Larghezza anta
Sash length

ASX.16.15

LT
Lunghezza tondino
Length of rod

Taglio asta collegamento (Ø 8mm)
Connecting rod cutting (Ø 8mm)

Taglio asta di collegamento con kit carrelli ASX.16.03
Connecting rod cutting with kit roller ASX.16.03

LT = LA - 630

Taglio asta di collegamento con kit carrello supplementare ASX.16.04
Connecting rod cutting with to use the additional roller ASX.16.04

LT = LA/2 - 408

LT = LA/2 - 408

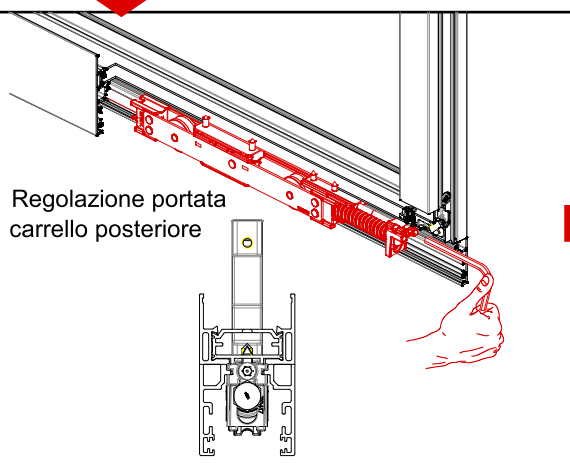
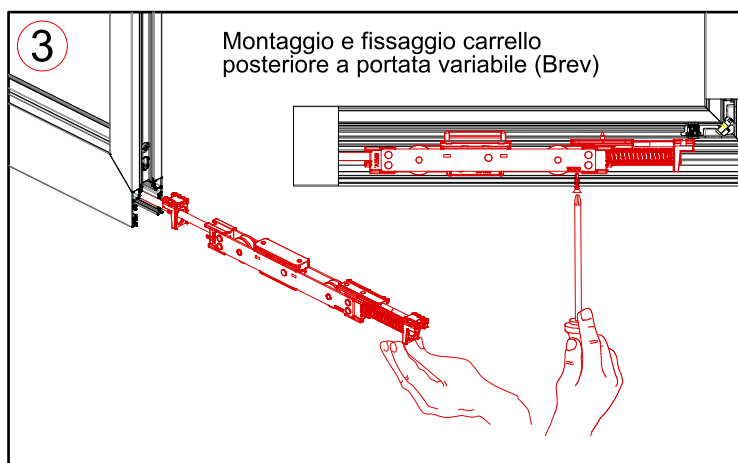
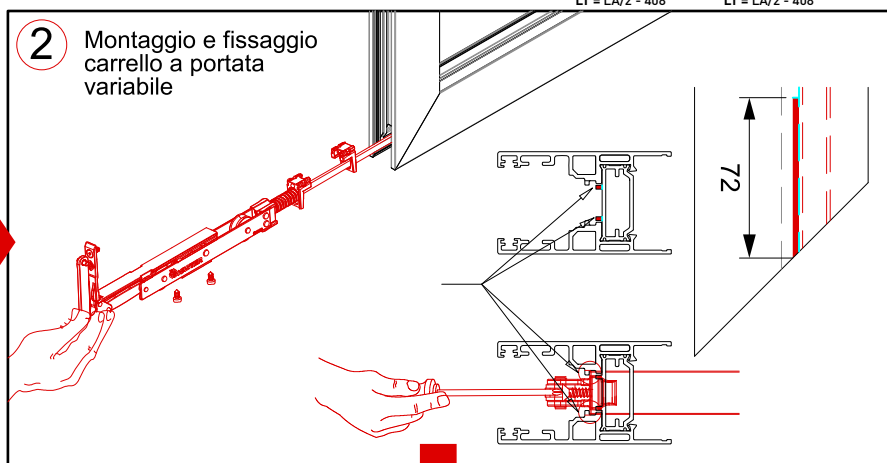
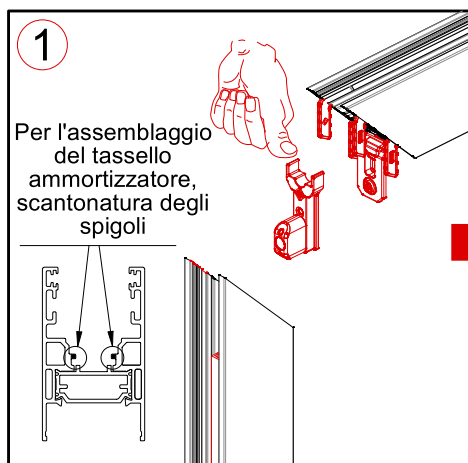

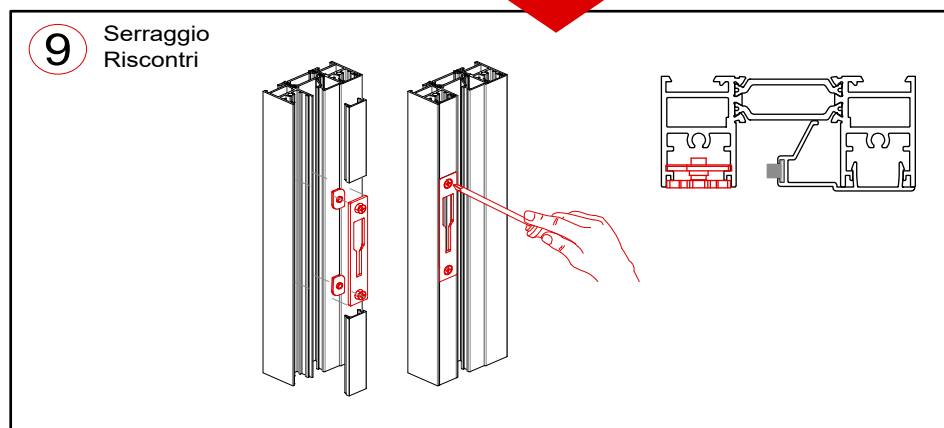
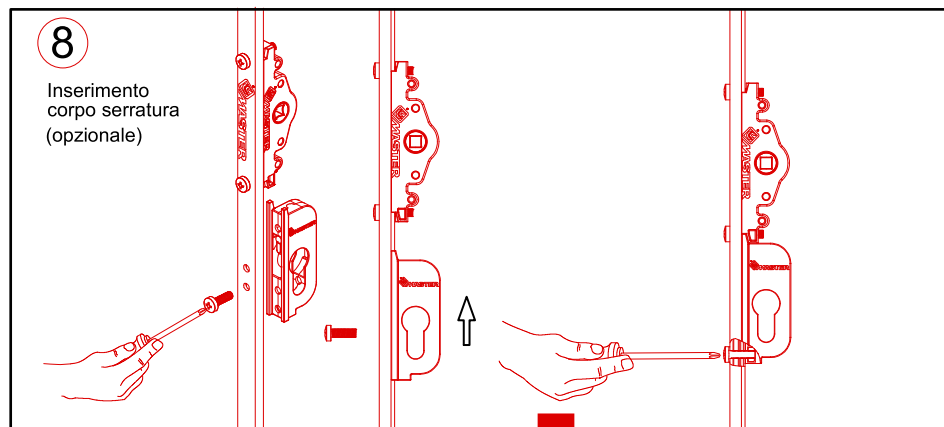
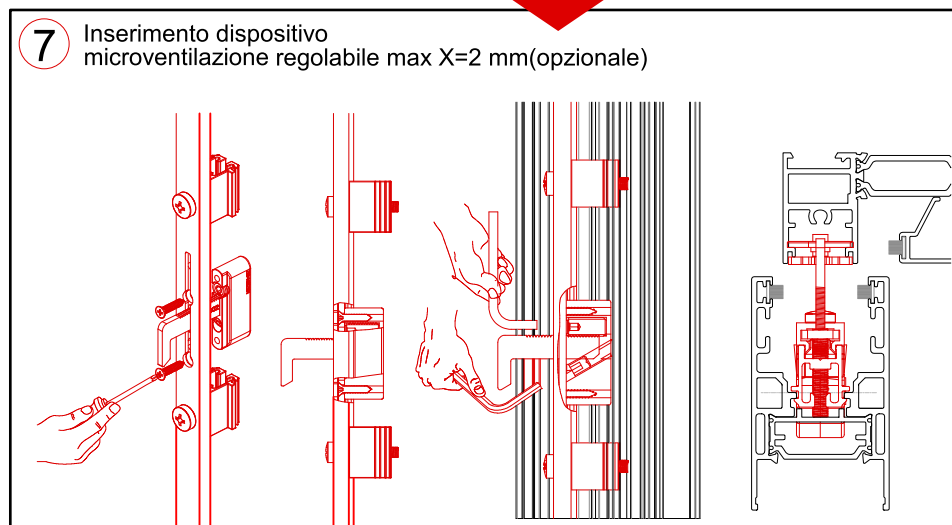
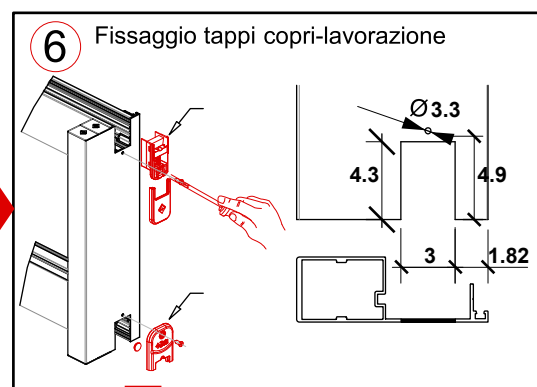
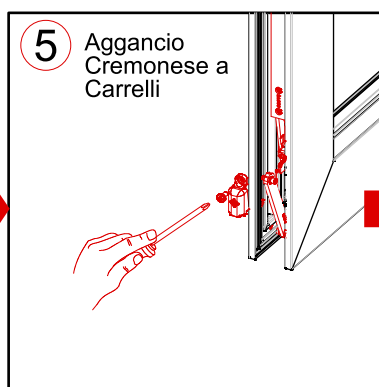
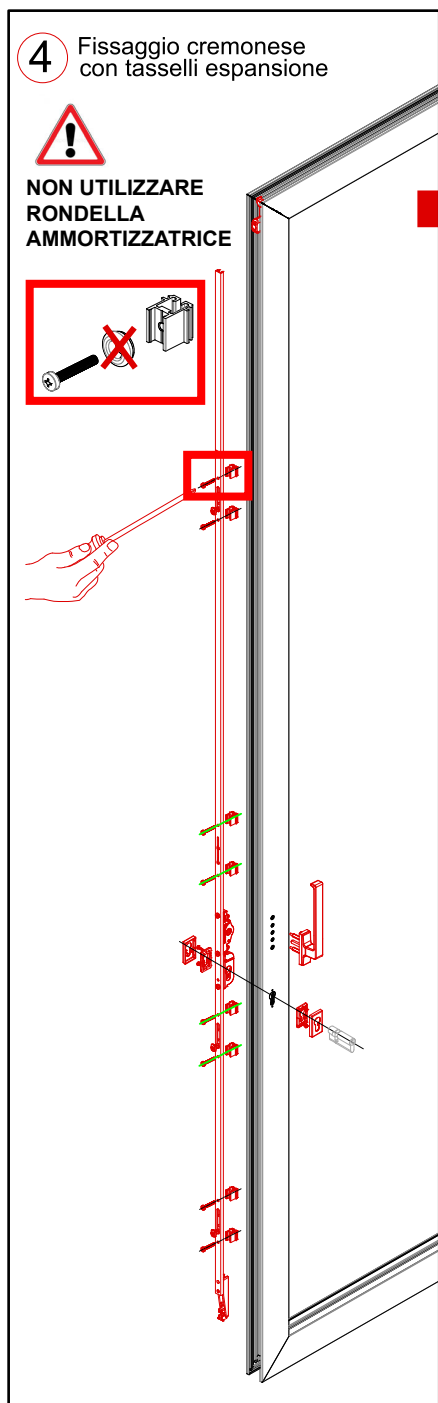



LAVORAZIONI MANIGLE SU ANTA ALZANTE SX85.204 /205 /206 /207 /208
MACHINING OF HANDLES ON LIFTING S ASH SX85.204 /205 /206 /207 /208

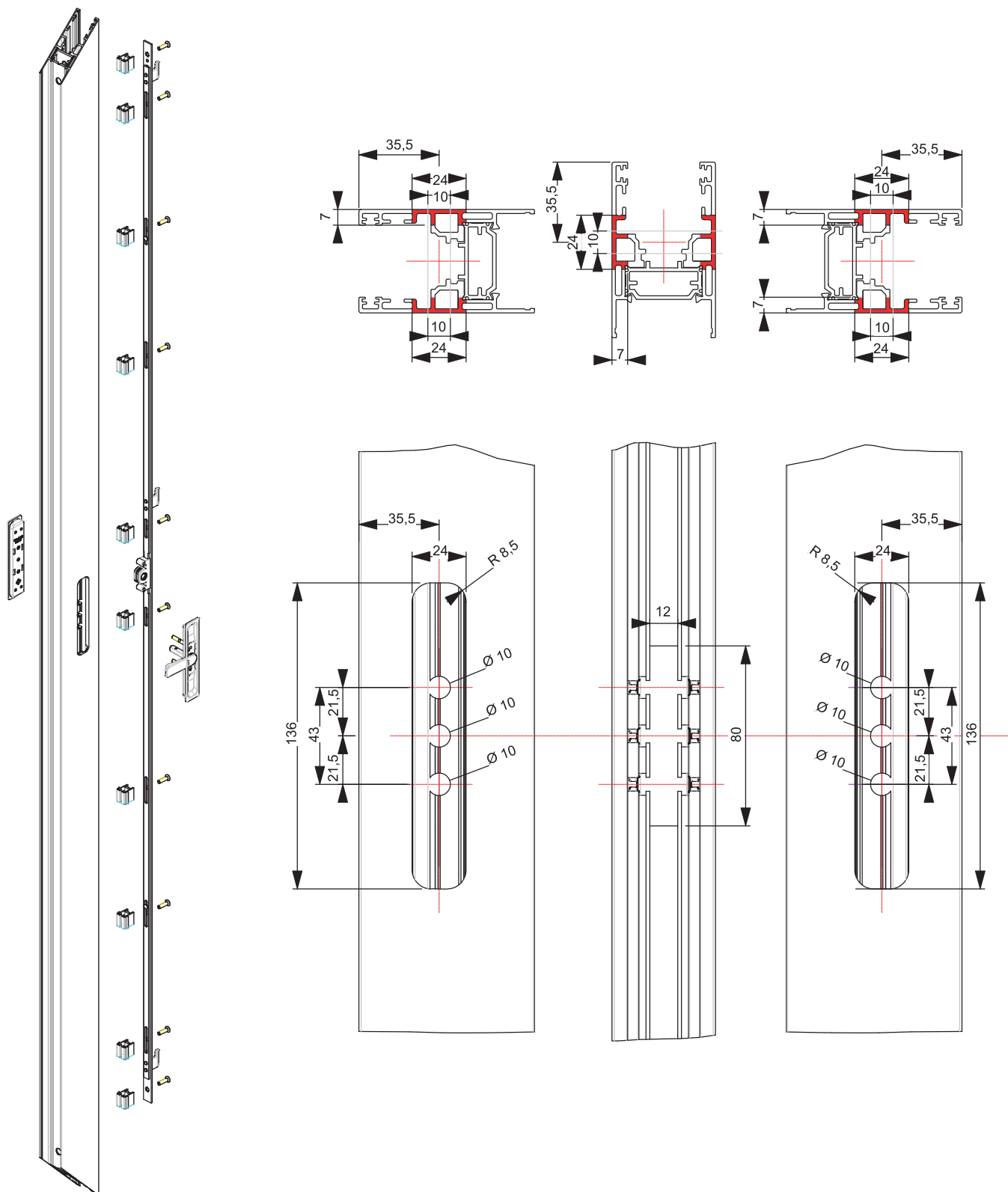

"AS 200" *Regolabile*
Kit cremonese

Campo di applicazione

Posizioni Contropiastra

Articolo	Ha min	Ha max	Punti chiusura	H 1	H 2	H 3	H 4
ASX.16.00R	1195mm	1795mm	2	212	974	-	-
ASX.16.01R	1796mm	2295mm	3	244	688	1148*	1574
ASX.16.02R	2296mm	2695mm	3	244	688	1148*	1974

* Posizione della microventilazione articolo ASX.16.09

Taglio
Cover copricava ASX 10.26

Articolo	A	B	C	C1*	C2*	D
ASX.16.00R	Hm - 195	643	Ha - (Hm+705)	-	-	-
ASX.16.01R	Hm - 795	358	766	340	307	Ha - (Hm+705)
ASX.16.02R	Hm - 795	358	1166	340	707	Ha - (Hm+1105)

* In caso di utilizzo della microventilazione articolo ASX.16.09 la cover C viene sostituita dalla cover C1 + C2

Posizione contropiastra e taglio cover **ASX 10.26**

Counterplate position and cover cut **ASX 10.26**

Taglio
Cover copricava ASX 10.26

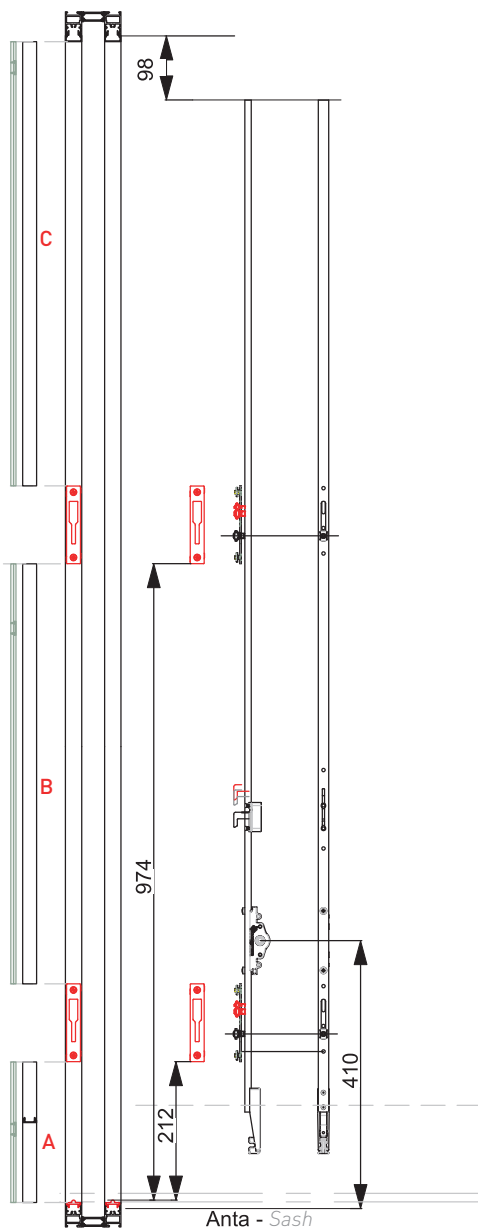

Taglio
Cover copricava ASX 10.26

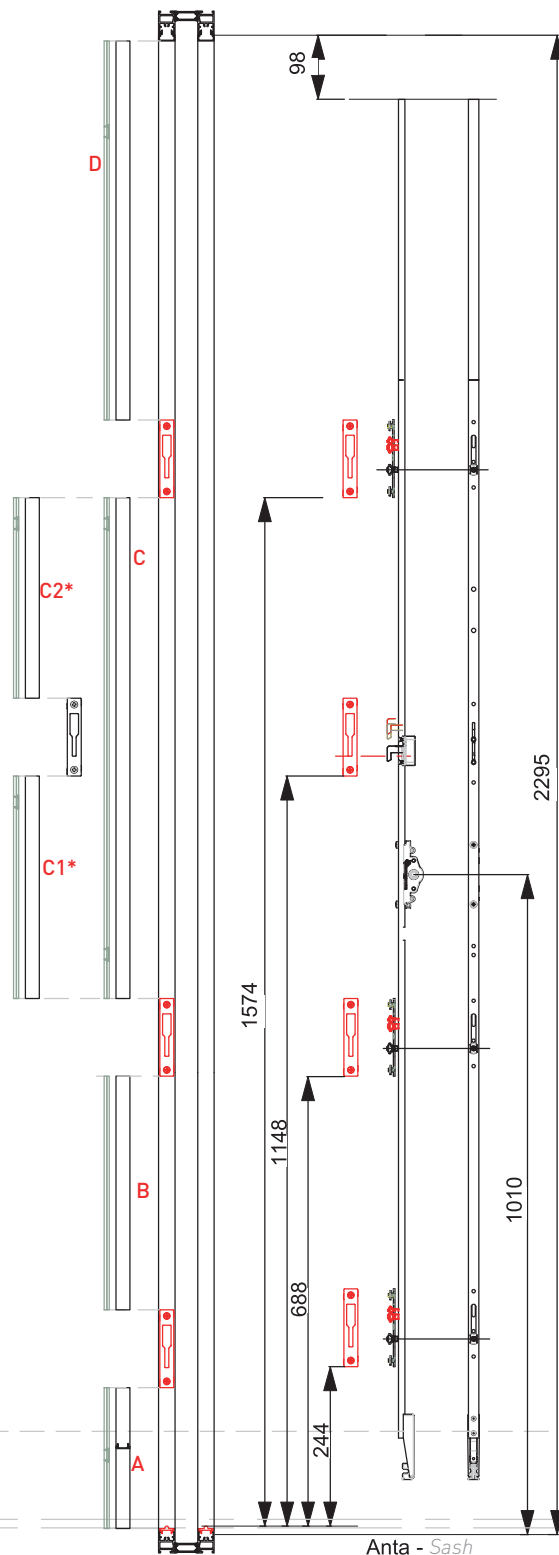



Taglio
Cover copricava
ASX10.26

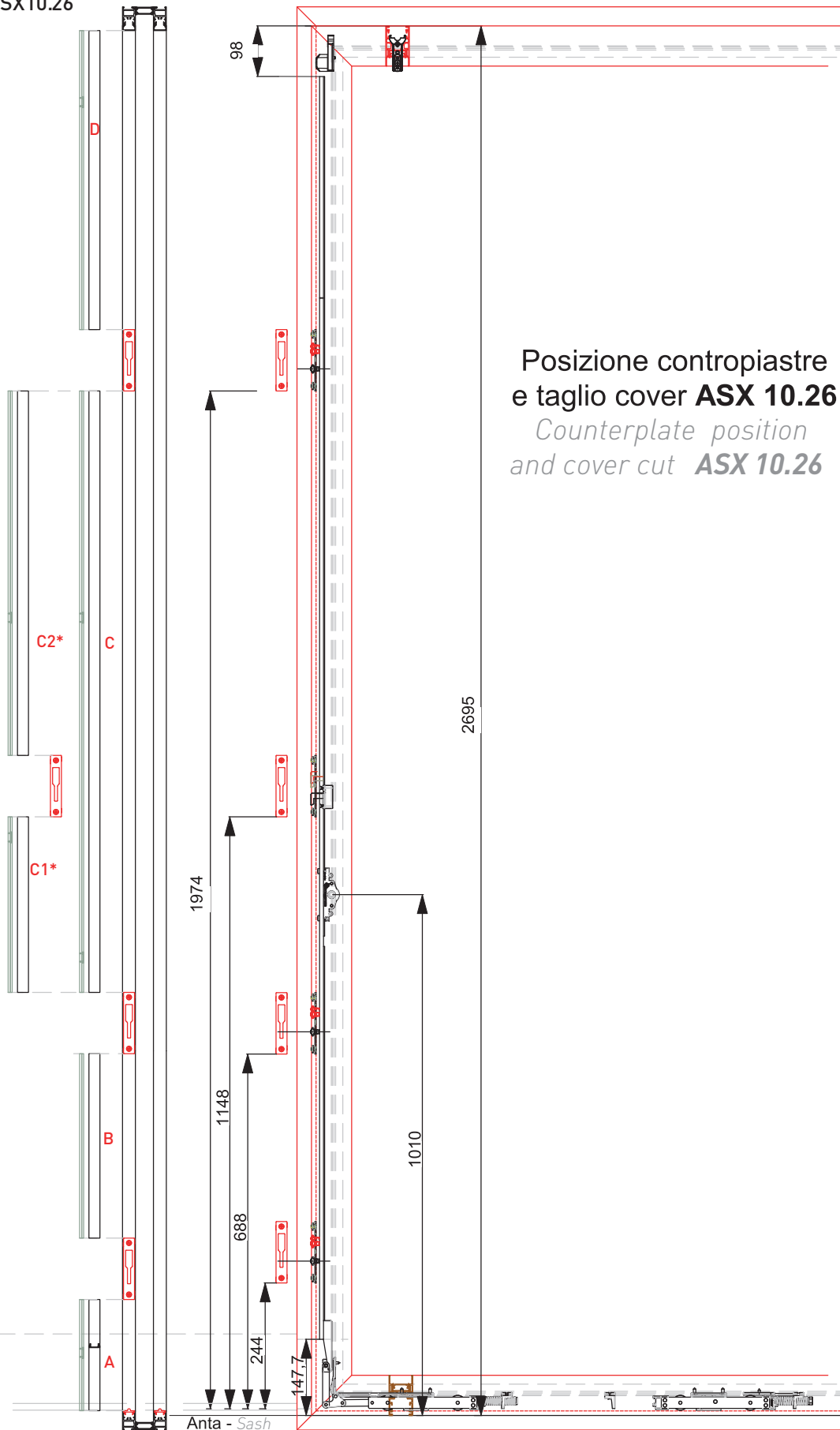

Gli archivi digitali dei prodotti TWIN SYSTEMS
sono disponibili nei formati:

*The digital files of the TWIN SYSTEMS
products are available in the formats at:*



www.twinsystems.it/web/richiesta-dwg

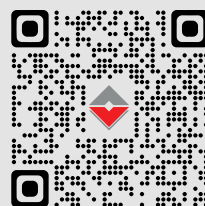

Il presente Catalogo assieme ai cataloghi di tutti i
prodotti TWIN SYSTEMS sono liberamente scaricabili:

*This Catalog together with the catalogs of all TWIN SYSTEMS
products can be downloaded freely at:*

www.twinsystems.it/professionisti/cataloghi/

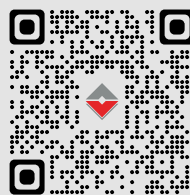

PAGINA Cataloghi
CATALOGUES Webpage

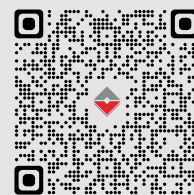

LINEA PRODOTTI
PRODUCTS Line

PAM SYSTEM S.r.L.

S.S. 230 - Fornace Crocicchio 13030 Formigliana (VL)
Tel. 0161 858811
www.pamsystemsrl.com | info@pamsystemsrl.com

ALQ GENOVA s.r.l.

Genova

Via Colano, 9/A 12/K 16162 Genova Bolzaneto [GE]
Tel. 010 7491941 - Fax 010 7450155

PAESANI GROUP

Direzione & Magazzino

Via del Grano, 260 47822 Santarcangelo di Romagna [RN]
Tel. 0541 748511
www.paesani.com - info@paesani.com

Magazzino Nord

Via Luigi Bonati, 21 29017 Fiorenzuola d'Arda [PC]
Tel. 0523 943138
magazzinonord@paesani.com

DIVA s.a.s

Via Po, 25 - Z.I. Sambuceto 66020 S.Giovanni Teatino [CH]
Tel. 085 4405210
www.camel-diva.com | info@camel-diva.com

EUROALL S.r.l.

Strada Comunale della Mola Saracena, 23 00065 Fiano Romano [RM]
Tel. 0765 455228/61
www.euroallslrl.it - info@euroallslrl.it

PROFILATI UMBRIA S.r.l.

Via Dei Tigli, 35 - 06083 Bastia Umbra [PG]
Tel. 075 8012385-075 8010328
profilatiumbria@virgilio.it

TSL ALLUMINIO S.r.l.

Via delle Industrie, 12 00030 San Cesareo [Roma]
Tel. 06 2251591 (Ric. Aut.)
www.tslalluminio.it - info@tslluminio.it

ALLCAR SERVICE S.r.l.

Via Acuto, 120 - 00131 Roma
Tel. 06 4130626 (Ric. Aut.)
allcarservice@mclink.it

ALLUCOM S.r.l.

Andria

Via Vecchia Barletta 237 Z. Ind. 76123 Andria [BT]
Tel. 0883 592213

Bari

Via Zippitelli, 28/B - 70123 (BA)
Tel. 0805058608
www.allucom.com - info@allucom.com

CARUSO S.r.l.

Z.I. Contrada Le Macere 86019 Vinchiaturro [CB]
Tel. 0874 340024
carusosr1@libero.it

CAIMAR S.n.c.

Direzione & Magazzino

Strada Prov.le Rimedio-Torregrande Km. 4
09072 Cabras [OR] - Tel. 0783 290118

Filiale

Fronte S.S. 131 Km. 17,450 - 09023 Monastir [CA]
Tel. 070 9166020
www.caimar.it - caimarmail@caimar.it

SALENTO METALLI S.r.l.

Via Federico II, 13 - Zona PIP - 73020 Cavallino [LE]
Tel. 0832 614576
www.salentometalli.it - info@salentometalli.it

MIDA ALLUMINIO S.r.l.

Napoli

Via Piano del Principe, 36
80047 San Giuseppe Vesuviano [NA]
Tel. 081 5297373

Salerno

Loc. Terzerie, Z.I. - 80061 Ogliastro Cilento [SA]
Tel. 0974 833233
www.gruppomida.it - info@gruppomida.it

ITALBACOLOR S.r.l.

C.da Valle S. Maria - 87024 Fuscaldo [CS]
Tel. 0982 618025
www.italbacolor.it commerciale@italbacolor.it

COMAS S.r.l.

Via Porta Palermo, 84 - 91011 Alcamo [TP]
Tel. 0924 507050 - 0883 592213
www.comasgroup.it - info@comasgroup.it

ALUK TIM

Aluk Tim D.o.o.

Žegoti 10, 51215 Kastav Croazia, UE
Tel: + 385 (0) 51/691 461

Filiale di Zagabria

Franje Lučića, 34A Zagabria Croazia, UE
Tel: +385 (0) 1 6462 611
Mob: +385 (0) 99 2939656
zagreb@aluk.hr

Filiale Spalato

Street Sv. Nikole Tavelića, 13A 21204
Dugopolje Croazia, UE
Tel: +385 (0) 21225525 |
Mob: +385 (0) 99 2199228
split@aluk.hr



   www.twinsystems.it
info@twinsystems.it

Consorzio **TWIN SYSTEMS**
Via delle Macere, 20 | 00060 Formello [Roma]
Tel./Fax 06 23260298