

CX650

FINESTRE A BATTENTE A TAGLIO TERMICO
CASEMENT WINDOWS W/THERMAL BREAK



TWIN
SYSTEMS

ARCHITETTURE IN ALLUMINIO

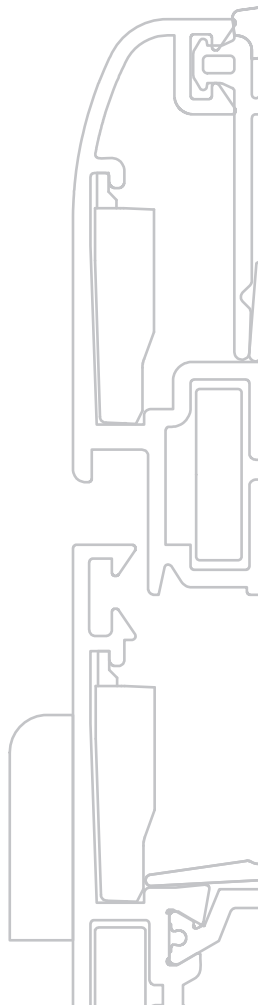

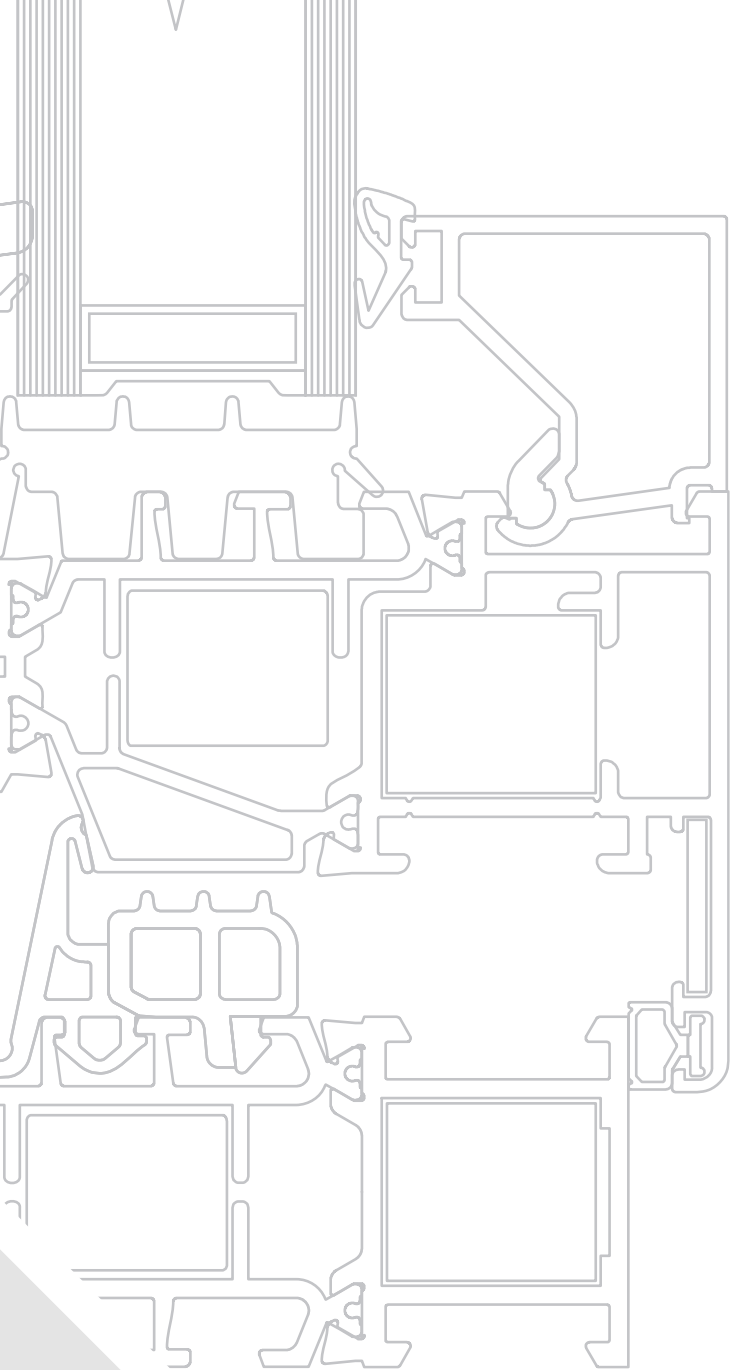

CX650

FINESTRE A BATTENTE A TAGLIO TERMICO
CASEMENT WINDOWS W/THERMAL BREAK





TWIN SYSTEMS

ARCHITETTURE IN ALLUMINIO

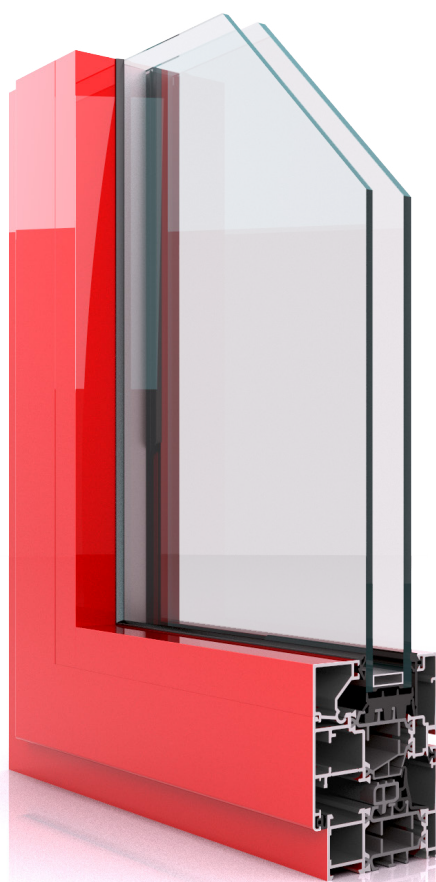

Gruppo A
Informazioni Generali
Informazioni Generali

Indice Generale
Caratteristiche Alluminio
Descrizione Tecnica sistema
Descrizione Tecnica Capitolato
Collaudi Prestazionali

Table of Contents
Aluminium Characteristics
Technical Description
Technical Specifications
Performance Tests

Gruppo B
Profili
Profiles

Elenco Profili
Profili Scala 1:1

Profiles List
Profiles Scale 1:1

Gruppo C
Accessori e Guarnizioni
Accessories and Gaskets

Elenco accessori
Elenco guarnizioni

List of Accessories
List of Window Gaskets

Gruppo D
Nodi
Main Sections

Sezioni principali
e Accessori
Sc. 1:1

Main Sections and
Accessories
Scale 1:1

Gruppo E
Tipologie
Types

Tipologie

Types

Gruppo F
Attacco alla Muratura
Wall Joint

Sezione particolareggiata
attacco alla muratura

Wall Joint Detail

Gruppo G
Lavorazioni/Montaggi
Tooling/Assembly

Schemi Lavorazioni
Frese
Attrezzatura

Tooling Systems
Cutters Equipments
Milling

Tutti i dati riportati sul presente catalogo sono indicativi e non impegnativi. La società si riserva il diritto di apportare in qualsiasi momento modifiche atte a migliorare i prodotti. Per informazioni tecniche riguardanti il catalogo contattare l'ufficio tecnico.

All the data shown in this catalog are indicative and not binding. The company reserves the right to make changes to improve the products at any time. For technical information regarding the catalog, contact the technical department.

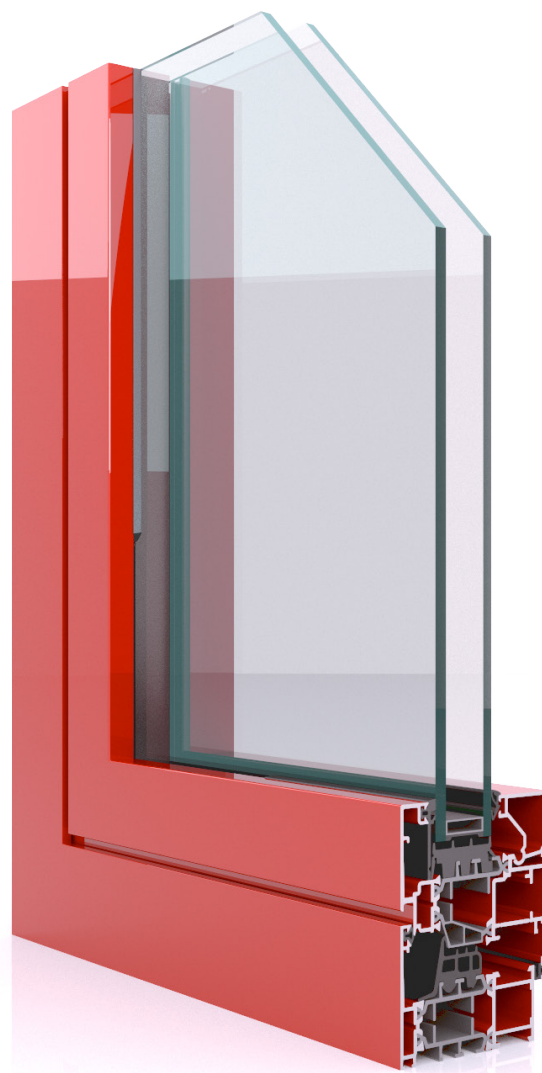

Informazioni Generali
General Information

Gruppo A

Indice Generale	<i>Table of Contents</i>
Caratteristiche Alluminio	<i>Aluminium Characteristics</i>
Descrizione Tecnica sistema	<i>Technical Description</i>
Descrizione Tecnica Capitolato	<i>Technical Specifications</i>
Collaudi Prestazionali	<i>Performance Tests</i>

**PESO PROFILATI**

Il peso indicato è quello teorico e potrà variare in funzione delle tolleranze di spessore e dimensionali dei profilati (NORMA UNI EN 12020-2)

LEGA DI ESTRUSIONE

I profilati sono estrusi in lega EN-AW-6060 (UNI EN 573/3)

DIMENSIONI DEI PROFILATI

Le dimensioni indicate sono quelle teoriche, potranno quindi variare in funzione delle tolleranze dimensionali di estrusione (norma UNI EN 12020-2). Questa variabilità che interessa tutti i profilati, può influire, anche se minimamente, sulle dimensioni di taglio e quindi finali del serramento. Anche la verniciatura, aumentando gli spessori, contribuisce a far variare la dimensione dei profilati e particolarmente, riduce lo spazio nelle sedi di inserimento delle guarnizioni e degli accessori.

DIMENSIONI DI TAGLIO E LAVORAZIONI

Le dimensioni teoriche di taglio e le quote delle lavorazioni indicate nel presente catalogo sono esatte, ovvero matematicamente corrette, in certi casi dovranno, nella pratica, essere adattate in base alla precisione ed al tipo di impostazione delle misure delle macchine utilizzate. È pertanto consigliabile nei primi lavori o nel caso di importanti quantità di serramenti effettuare delle campionature di prova.

PROTEZIONE SUPERFICIALE

Al fine di limitare i processi di corrosione filiforme è importante applicare le seguenti regole:

- ◆ Utilizzare accessori di assemblaggio in alluminio
- ◆ Utilizzare viti in acciaio inox
- ◆ Proteggere le parti tagliate e lavorate con prodotti idonei
- ◆ Evitare ristagni di condense all'interno dei profilati

Per la realizzazione di serramenti è necessario attenersi alla tecnologia costruttiva e utilizzare le guarnizioni e gli accessori originali riportati sul catalogo tecnico e al rispetto delle norme, prescrizioni e raccomandazioni vigenti. L'osservanza di quanto sopra determina la garanzia.

Su queste basi sono stati realizzati campioni che, collaudati in laboratorio hanno ottenuto i risultati indicati nelle certificazioni. Per il buon funzionamento e la durata degli infissi realizzati con profilati ed accessori del sistema, è necessario effettuare alcune semplici operazioni:

una buona pulizia, eliminando residui di calce, cemento e/o altro.

È consigliabile peraltro proteggere il manufatto sino al momento della messa in esercizio, lubrificare con olio o grasso neutri le parti in movimento e gli organi di chiusura, controllare il corretto serraggio delle viti e dei grani, controllare gli assetti, registrandoli laddove sono previste regolazioni. Si raccomanda di effettuare queste operazioni almeno con cadenza semestrale. In caso di funzionamento anomalo di qualche componente, evitare assolutamente interventi atti a modificarne le caratteristiche e la sostituzione con ricambi non originali. Ci sembra utile ricordare che interventi di regolazione e/o sostituzione, con particolare riferimento ai meccanismi per oscillo-battente, andranno eseguiti da personale specializzato. Si raccomanda inoltre, in occasione delle operazioni di pulizia, di non utilizzare detergenti che possano deteriorare i trattamenti superficiali, escludendo tassativamente acidi, solventi, materiali abrasivi, spazzole metalliche o comunque in grado di scalfire le superfici, pagliette metalliche e altro.

WEIGHT OF PROFILES

The weight indicated is the theoretical one and may vary depending on the thickness and dimensional tolerances of the profiles (STANDARD UNI EN 12020-2)

EXTRUSION ALLOY

The profiles are made of extrusion alloy EN-AW-6060 (UNI EN 573/3)

DIMENSIONS OF PROFILES

The dimensions indicated are the theoretical ones; they may vary depending on the extrusion dimensional tolerances (STANDARD UNI EN 12020-2). This variability, which affects all the profiles, can affect, even if minimally, the cutting size and, therefore, the final size of the window. Also the coating, increasing the thickness, affects the size of the profiles and, in particular, reduces the space in the housing of window gaskets and accessories.

CUTTING AND TOOLING DIMENSIONS

The theoretical cutting and tooling sizes indicated in this catalogue are accurate, that is, they are mathematically correct. In practice, in some cases they may need to be adapted to take into consideration the precision and dimensional settings of the machines used. We therefore recommend that test samples be made in the first jobs or in the case of large quantities of windows.

SURFACE PROTECTION

The rules below should be followed to limit filiform corrosion phenomena:

- ◆ Use aluminium assembly accessories
- ◆ Use stainless steel screws
- ◆ Use appropriate products to protect cut and tooled parts.
- ◆ Prevent condensation from accumulating inside the profiles

When making the windows, comply with the construction technology, use original window gaskets and accessories as listed in the technical catalogue and comply with applicable standards, provisions and recommendations. Non-compliance with the above rules invalidates the warranty. Samples have been made on these bases that, tested in the laboratory, have obtained the results indicated in the certifications. Some simple actions are necessary for the proper functioning and durability of window frames made with the system's profiles and accessories: good cleaning, eliminating traces of lime, cement, etc.

The product should be protected until the time of installation, lubricate moving parts and closing devices with neutral oil or grease, check that the screws and grub screws are tightened, check the trims, adjusting them where necessary. These operations should be carried out at least once every six months. Should any component not function correctly, do nothing to modify its characteristics and do not use non-original spare parts. Remember that adjustments and/or replacements, with special reference to tilt&turn mechanisms, must be carried out by specialized personnel.

During cleaning operations, detergents that can damage surface treatments - e.g. acids, solvents, abrasive materials, metal brushes or in any case able to scratch the surfaces, steel wool, etc. - should not be used.



DIMENSIONI E TIPOLOGIA DEI SERRAMENTI

La valutazione delle dimensioni dei serramenti, richiede la considerazione di vari fattori quali: il momento d'inerzia dei profilati, le dimensioni e il peso dei tamponamenti (vetri-pannelli), la larghezza e l'altezza delle parti apribili, caratteristiche e portate degli accessori, le condizioni e le quantità degli ancoraggi alle opere morte, l'esposizione, ecc... Fattori che sono valutabili e applicabili, grazie alla buona conoscenza dello stato dell'arte, alle informazioni riportate dai cataloghi, manuali tecnici e dalle normative vigenti. Consigliamo, al fine di evitare inutili contestazioni, di consultare il nostro servizio tecnico sistemi, prima di realizzare serramenti che, per dimensione, forma, esposizione e/o altro possono essere ritenuti atipici. Le soluzioni e le combinazioni proposte in questo catalogo, non hanno carattere limitativo, ma presentano solo le situazioni e combinazioni più comunemente riscontrabili nella realtà. Soluzioni e combinazioni diverse, così come l'adozione di componentistica particolare, ad esempio meccanismi per la realizzazione di ante scorrevoli parallele, ante scorrevoli a libro o altro, sono possibili. A questo proposito il nostro servizio tecnico prodotti per l'edilizia può valutare e proporre le soluzioni più idonee.

DIMENSIONS AND TYPE OF WINDOWS

Various factors must be taken into consideration when assessing the dimensions of the windows, such as: the moment of inertia of the profiles, the dimensions and weight of the panels (glass-panels), the width and height of the opening parts, the characteristics of the accessories, the condition and number of fastenings to the dead work, the exposure, etc. These factors can be assessed and applied, thanks to the good knowledge of the state of the art and to the information reported in catalogues, technical manuals and current regulations.

In order to avoid needless complaints, we invite you to contact our technical service before making windows that, due to their size, shape, exposure and/or other characteristic, could be considered non-standard. The solutions and combinations proposed in this catalogue are not the only ones available, but merely represent the most common situations and combinations. Different solutions and combinations, as well as the use of particular components, for example mechanisms for parallel sliding doors, folding sliding doors etc., are available. In this regard, our building products technical service can study and propose the most suitable solutions.

**COMPOSIZIONE PROFILATI**

I profilati per serramenti saranno in lega di alluminio ENAW 6060 (EN 573-3 e EN 755-2) con stato fisico di fornitura UNI EN 515. I telai fissi e le ante mobili dovranno essere realizzati con profilati ad interruzione di ponte termico a tre camere (profilo interno ed esterno tubolari, collegati tra di loro con barrette inb poliammide PA6.6 rinforzate con fibra di vetro).

INFISSI

Le finestre e le porte finestre dovranno avere un profilato di telaio fisso con profondità minima 65 mm. ed un profilato di anta mobile con profondità minima 73 mm. I profilati di telaio fisso dovranno prevedere, dove necessario, alette incorporate di battuta interna sulla muratura da 22 mm.

I profilati di ante mobili dovranno avere un'aletta esterna di battuta per vetro con altezza di 22 mm ed una aletta di battuta interna sul telaio fisso con sormonto di 6 mm. La barretta in poliammide del profilato anta a contatto con la guarnizione di tenuta centrale (giunto aperto), dovrà essere di forma tubolare.

ISOLAMENTO TERMICO

L'interruzione del ponte termico sarà ottenuta da barrette continue in poliammide da 28-36 mm totale e dovrà garantire un valore di trasmittanza termica per l'infisso $U_w = \dots\dots\dots W/m^2K$. In caso di necessità di prestazioni termiche più performanti è possibile l'utilizzo di barrette STEADYTECH.

L'assemblaggio dei profilati in alluminio a taglio termico dovrà garantire i valori di scorrimento (T) tra profilati in alluminio e barrette in POLIAMMIDE previsti dalla direttiva tecnica Europea (UEAtc).

DRENAGGI E VENTILAZIONE

I profilati esterni delle ante mobili dovranno prevedere una gola ribassata per la raccolta delle acque di infiltrazione e di condensa onde poter permettere il libero deflusso delle stesse attraverso apposite asole di scarico. Le barrette in poliammide dovranno avere una conformazione geometrica atta ad evitare eventuale ristagno di acque di infiltrazione e di condensa ed essere perfettamente complanari con le pareti trasversali dei profilati di alluminio.

ACCESSORI DI ASSEMBLAGGIO

Le giunzioni tra profilati orizzontali e verticali dovranno essere perfettamente solidali e ben allineate tra di loro, sia nella parte esterna che interna dei profilati ed unite mediante apposite squadrette a bottone o, in alternativa, in alluminio estruso o pressofuso, con metodo a spino-cianfrinatura od a cianfrinatura totale. Le sezioni dei profilati orizzontali e verticali dovranno essere opportunamente sigillate prima di essere unite con le squadrette. I fermavetri saranno accoppiati a scatto e posizionati nei canali dei profilati in alluminio.

GUARNIZIONI

Tutte le guarnizioni: cingivetro, di tenuta, di battuta.... dovranno essere in elastomero (EPDM). In particolare la guarnizione di tenuta centrale (giunto aperto) dovrà assicurare la continuità perimetrale mediante l'impiego di angoli vulcanizzati preformati incollati alla stessa o in alternativa mediante telai vulcanizzati.

PRESTAZIONI

I serramenti dovranno avere prestazioni di permeabilità all'aria, tenuta all'acqua e resistenza ai carichi del vento conformemente alle norme:
(UNI-EN 12207 - 12208 - 12210 e UNI-EN 1026 - 1027 - 12211)

PROFILE COMPOSITION

The window profiles are made of ENAW 6060 aluminum alloy (EN 573-3 and EN 755-2) with physical state of supply UNI EN 515. The fixed frames and sliding doors must be made with three-chamber thermal break profiles (tubular internal and external profile, connected to each other with glass fibre reinforced polyamide PA6.6 bars).

DOORS AND WINDOWS

The windows and French doors must have a fixed frame profile with a minimum depth of 65 mm and a sliding door profile with a minimum depth of 73 mm. Where necessary, the fixed frame profiles must have an incorporated 22 mm internal stop flap on the brickwork.

The profiles of sliding doors must have an external stop flap for glass with a height of 22 mm and an internal stop flap on the fixed frame with overlap of 6 mm. The polyamide bar of the door profile in contact with the central sealing gasket (open joint), must be tubular.

THERMAL BREAK

The thermal bridge will be interrupted using solid 28-36 mm polyamide bars guarantee a heat transmission value of the frame $U_w = \dots\dots\dots W/m^2K$. In case of need for more efficient thermal performance, it is possible to use STEADYTECH clips. The assembly of aluminum profiles with thermal break will guarantee the slide values (T) between the aluminium profiles and polyamide bars set forth in the European Technical Directive (UEAtc).

DRAINAGE AND VENTILATION

The external profiles of the sashes will have a lowered drainage channel for the infiltration and the condensation water in order it to flow properly true the special drainage slots. The polyamide bars have a geometric conformation suitable to avoid any stagnation of infiltration and condensation water and are perfectly coplanar with the transversal walls of the aluminum profiles.

ASSEMBLY ACCESSORIES

The joints between the horizontal and vertical profiles must be perfectly united and correctly aligned with each other, both externally and internally and joined by means of special slot corner joints or, alternatively, in extruded or die-cast aluminum, with a dowel-crimping or full crimping method. The sections of the horizontal and vertical profiles must be properly sealed before being joined with the corner joints. The glazing beads will be snap-coupled and positioned in the channels of the aluminum profiles.

WINDOW GASKETS

All window gaskets: glazing, sealing, rabbet.... must be made of elastomer (EPDM). Specifically, the central sealing gasket (open joint) must ensure perimeter continuity using preformed vulcanized corner joints glued to it or, alternatively, vulcanized frames.

PRESTAZIONI

I serramenti dovranno avere prestazioni di permeabilità all'aria, tenuta all'acqua e resistenza ai carichi del vento conformemente alle norme:
(UNI-EN 12207 - 12208 - 12210 e UNI-EN 1026 - 1027 - 12211)

Caratteristiche Fisiche / Physical Characteristics:

- Squadretta Allineamento Nylon o Serraggio Meccanico / Nylon or Mechanical Tightening Corner Joint Squadretta a Cianfrinare/Spinare Riveting/crimping corner joint
- Sormonto Battuta 4 mm. / Rabbet overlap 4 mm. Precamera 4,01 cm² / Prechamber 4,01 cm²
- Squadretta Allineamento Nylon o Serraggio Meccanico / Nylon or Mechanical Tightening Corner Joint Squadretta a Cianfrinare/Spinare Riveting/crimping corner joint
- Guarnizioni Vetro Tubolari / Tubular Glass Seals
- Fermavetro di Sicurezza H sede Vetro 22 mm. A Norma Europea / Safety-height glazing bead Glass Seat 22 mm. European Standard
- Squadretta a Bottone/Cianfrinare/Spinare Riveting/crimping corner joint
- Accessori a Camera Unificata / Unified Chamber Accessories Housing Guarnizione Centrale a più Tubolarità / Multi-tubular Central Seal
- Guarnizione Battuta a Scatto ed Infilo / Snap-On Rabbet Weatherstrip

Caratteristiche Fisiche / Physical Characteristics:

Tecnologia:

- Sistema a camera multipla ad elevato isolamento termico con design simmetrico e qualità dell'assemblaggio garantita.
- Spessore dei tamponamenti fino a 55 mm.

FERRAMENTA:

- Sistema con accessori funzionali a camera unificata, spazio 11.5 mm. personalizzati ed a pista 16 mm.
- Giunzione angolare con squadrette a bottone/spinare/ cianfrinare ed allineamento.

IMPIEGO:

- Profilati per finestre che consentono la costruzione di infissi ad una, due o più ante a battente, nella versione a giunto aperto complanari all'esterno e a sormonto all'interno. Sono possibili anche specchiature fisse, wasistas, anta-ribalta. Profilati per porte: consentono la costruzione di porte ad una o due ante, apribili all'interno, con sopraluci fissi od apribili e vetrine.

PHYSICAL CHARACTERISTICS:

Technology:

- High thermal break multi-glazing system with symmetrical design and guaranteed assembly quality.
- Panel thickness up to 55 mm.

HARDWARE:

- System with functional customized accessories with unified chamber, space 11.5 mm and track 16 mm.
- Corner joint with slot joints / dowelling/crimping and trimming.

USE:

- Window profiles for the construction of single-, double- or more-casement windows, in the open joint version coplanar on the outside and overlapping on the inside. Mirrored, transom, tilt&turn are also possible. Door profiles: allow the production of windows with single or double doors, openable from the inside, with fixed or openable hopper windows and glazing.

CARATTERISTICHE FISICHE | PHYSICAL CHARACTERISTICS

- ◆ Telaio Fisso | Fixed Frame: 65 mm.
- ◆ Telaio Mobile | Window Frame: 73 mm.
- ◆ Barrette Isolanti | Insulating Rods: 28 - 36 mm.
- ◆ Fuga Perimetrale | Perimeter Gap: 5 mm.
- ◆ Alloggiamento Accessori | Accessories Housing: Camera Europea dim. 11.5 mm. [European Chamber]
- ◆ Giunzione Angolare | Corner Joint: Bottone, Spinare, Cianfrinare [Dowelling/Crimping and Trimming Rivetting Slot]

PRESTAZIONI CERTIFICATE | CERTIFIED PERFORMANCES

AAV

- ◆ Permeabilità all'aria | Air Permeability: Classe 4
- ◆ Tenuta all'acqua | Watertightness: Classe E 1500
- ◆ Carico di vento | Wind load resistance: Classe C5
- ◆ Isolamento acustico | Sound Insulation: fino a 47 dB
- ◆ Resistenza all'effrazione | Breakage resistance: Classe RC 3

Risultati dei test / CE product pass conforme ad:

Tests Results / CE product pass Compliant with:
UNI EN 14351-1:2006+A1:2010

TRASMITTANZA | TRANSMITTANCE

1 ANTA | Single SASH: $U = 1.18 \text{ W/(m}^2\text{K)}$
 2 ANTE | Double SASH: $U_{wv} = 1.25 [1.21^*] \text{ W/(m}^2\text{K)}$
*Valore ottenuto con barrette STEADYTECH bars

SERRAMENTO CAMPIONE | SAMPLE FRAME

- ◆ Vetro Certificato | Certified Glass: Double Glazing $U_g = 1.0 \text{ W/(m}^2\text{K)}$
- ◆ Canalina | Duct: $\psi_i = 0.036 \text{ W/(m}^2\text{K)}$
- ◆ Finestra normalizzata | Normalized Window: H = 1480 mm. ed L = 1535 mm.

1 ANTA | Single SASH: $U = 0.86 \text{ W/(m}^2\text{K)}$
 2 ANTE | Double SASH: $U_{wv} = 0.96 [0.92^*] \text{ W/(m}^2\text{K)}$
*Valore ottenuto con barrette STEADYTECH bars

SERRAMENTO CAMPIONE | SAMPLE FRAME

- ◆ Vetro Certificato | Certified Glass: Triple Glazing $U_g = 0.6 \text{ W/(m}^2\text{K)}$
- ◆ Canalina | Duct: $\psi_i = 0.031 \text{ W/(m}^2\text{K)}$
- ◆ Finestra normalizzata | Normalized Window: H = 1480 mm. ed L = 1535 mm.

Dimensioni massime ammesse per il calcolo Uw su serramento campione fino a 2.3 m² (secondo norma UNI EN 14351-1:2006+A1:2010)

Maximum allowable dimensions for calculation of the Uw on sample window frame up to 2.3 m² (according to UNI EN 14351-1:2006+A1:2010)

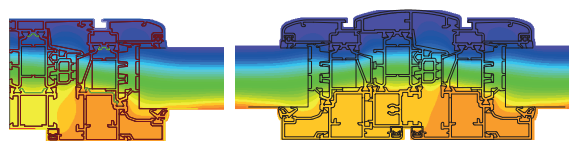

Analisi termica con FLIXO vers.8 e WinIso2D Professional 7.8
Thermicon FLIXO vers.8 e WinIso2D Professional 7.8



Tenuta all'Acqua
Watertightness



Capacità di un inso di impedire infiltrazioni quando è investito da un flusso d'acqua ed è presente una differente pressione tra interno ed esterno.
Capacity of a window to prevent infiltrations when impacted by a gush of water and there is a different internal and external pressure.

Press.	0Pa5	0Pa	100Pa	150Pa	200Pa	250Pa	300Pa	450Pa	600Pa	750Pa	900Pa	1050Pa	1200Pa	1350Pa	1500Pa	Pressure
Velocità	03	24	55	56	47	27	89	6	111	126	138	149	159	169	178	Speed
Classe	-1	A2	A3	A4	A5	A6	A7	A8	A	E750	E900	E1050	E1200	E1350	E1500	Class

L'infisso TWIN, con una pressione del vento pari ad una velocità di 178 Km/h (1500Pa) non ha avuto infiltrazioni
The frame TWIN with a wind pressure equal to a speed of 178 Km/h (1500Pa), had no infiltrations

Classe | Class
E1500
EN 1027 - EN 12208

Tenuta all'Aria
Air Permeability



Caratteristica di un inso chiuso di lasciare trarre aria quando è presente una differenza di pressione tra l'interno e l'esterno; minori saranno i volumi dispersi, maggiore sarà la qualità del serramento.
Characteristic of a closed window to let air filter through when there is a different internal and external pressure; the lower the dispersed volumes, the higher the quality of the frame.

Press.	150Pa	300Pa	450Pa	600Pa	Pressure
Classe	1	2	3	4	Class

L'infisso TWIN ha superato la prova con Pressione Vento = 111 k/h (600Pa)
The frame TWIN has passed the test with a Wind Pressure = 111 Km/h (600Pa)

Classe | Class
4
EN 1026 - EN 12207

Resist. al Vento
Wind Resistance

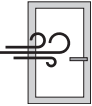

Capacità di un inso sottoposto a forti pressioni e/o depressioni, come quelle causate dal vento, di mantenere una deformazione ammissibile, di conservare le proprietà iniziali a salvaguardia della sicurezza degli utenti.
Capacity of a window subject to high positive and/or negative pressures, like that caused by the wind, to maintain an admissible deformation, to conserve its initial properties and to safeguard users against breakage.

Press.	400Pa	800Pa	1200Pa	1600Pa	2000Pa	>2000Pa	Pressure
Flessione	A (≤ 1/150)		B (≤ 1/200)		C (≤ 1/300)		Flexure
Classe	12		34		5E	xxx	Class

* Serramento a 2 ante, dimensione L = mm.1495 ed H = mm.1500 - Certificato n° RP n° 1994-CPD-RP1836 (Altre Certificazioni Disponibili)
Double Casement window, dimension L = mm.1495 ed H = mm.1500 - Test certificate no. RP no. 1994-CPD-RP1836 (Other certifications available).

Classe | Class
C5
EN 12211-EN 12210

Fonoisolamento
Sound Insulation



Perdita di isolamento acustico rispetto al vetro DR_w (dB) a partire dalla classe di permeabilità all'aria dell'infisso (UNI EN 12207)
Capacity of a window to resist violent intrusion following the application of a physical force or with the aid of tools.

Classe	1	2	3	4	Class	DR _w ≤ 38 dB	Amnesso l'utilizzo di questo metodo tabellare Admitted This table method
Perdita	8dB	6dB	4dB	2dB	Loss	DR _w > 39 dB	Necessario realizzare un campione al vero e sottoporre a prove di Laboratorio. An actual sample must be made and tested in the laboratory.

Serramento a 1 anta, dimensione L = mm.1230 ed H = mm.1480 - Certificato n° RP n° 0559-RP-2023 (Altre Certificazioni Disponibili)
Casement window, dimension L = mm.1230 ed H = mm.1480 - Test certificate no. RP no. 0559-RP-2023 (Other certifications available).

Abbattimento Acustico
Noise Reduction
47 dB
EN ISO140-3 | 717-1

Trasmissione
Transmittance

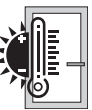

Flusso di calore che passa attraverso il serramento per m2 di superficie e per ogni grado di differenza di temperatura tra interno ed esterno.
Flow of heat that passes through the window per m2 of surface and for every degree of difference in temperature between outdoors and indoors.

U _w	1.25 W/m²K	Barrette INSULBAR LI	1.21 W/m²K	Barrette STEADYTECH
	Finestra a 2 ante normalizzata (1535 mm. x 1480 mm; vetro doppio U _g =1.0 W/m²K certificato con canalina psi=0.036 W/m²K) Normalised 2 Sashes window (1535 mm x 1480 mm; double glazing U _g =1.0 W/m²K certified with duct psi=0.036 W/m²K)			
U _w	0.96 W/m²K	Barrette INSULBAR LI	0.92 W/m²K	Barrette STEADYTECH
	Finestra a 2 ante normalizzata (1535 mm. x 1480 mm; vetro triplo U _g =0.6 W/m²K certificato con canalina psi=0.031 W/m²K) Normalised 2 Sashes window (1535 mm x 1480 mm; triple glazing U _g =0.6 W/m²K certified with duct psi=0.031 W/m²K)			

Antieffrazione
Breakege Resistance



Capacità di un infisso di resistere ad un'intrusione violenta a seguito di una applicazione di una forza fisica e con l'aiuto di attrezzi Finestra a 2 ante (1230 mm. x 1480 mm) - CERTIFICATO RT-480-2023
Capacity of a window to resist violent intrusion following the application of a physical force or with the aid of tools. 2 sashes window (1230 mm x 1480 mm) - RT-480-2023 CERTIFIED door

Classe	RC1	RC2	RC3
Intrusione	Forza Fisica (Calci, Pugni, Spallate)	Semplice Attrezzatura (Cunei, Cacciaviti)	R2 + Piede di Porco
Intrusion	Physical strength (kicks, pushing, pushing with shoulder)	Simple Tools (Wedges, Screwdrivers)	R2 + Crowbar

L'infisso TWIN, resiste in modo efficace ai tentativi di intrusione interna.
The TWIN window effectively resists attempted breaks

Resistenza Effrazione
Breakege Resistance
RC 3



Battente una e Due Ante
Single and Double Sash Casement Window

TIPO Type	ARTICOLO Item	PORTATA Load Capacity
	ACX 02.01 CERNIERA A MONTAGGIO RAPIDO 2Ali <i>FAST INSTALLING HINGE 2Wings</i>	 100% = 80Kg
	ACX 02.03 CERNIERA A MONTAGGIO RAPIDO 3Ali <i>FAST INSTALLING HINGE 3Wings</i>	
	ACX 02.03 CERNIERA A MONTAGGIO RAPIDO 3Ali <i>FAST INSTALLING HINGE 3Wings</i>	 100% = 80Kg

In alcuni schemi sono indicate cerniere in colore blu ed è suggerita l'applicazione per finestre/porte in ambienti pubblici.
Some diagrams show blue hinges and suggest their use for windows/doors in public areas.

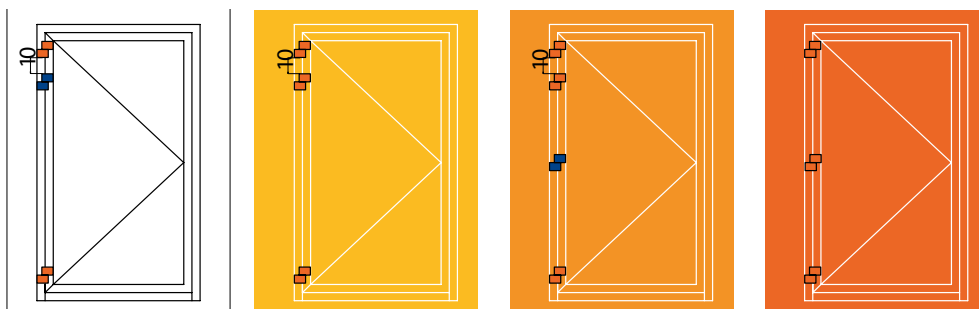

2800	100%	100%	100%	100%	100%	100%	100%	100%	100%
2700	100%	100%	100%	100%	100%	100%	100%	100%	100%
2600	100%	100%	100%	100%	100%	100%	100%	100%	100%
2500	100%	100%	100%	100%	100%	100%	100%	100%	100%
2400	100%	100%	100%	100%	100%	100%	100%	100%	100%
2300	100%	100%	100%	100%	100%	100%	100%	100%	100%
2200	100%	100%	100%	100%	100%	100%	100%	100%	97%
2100	100%	100%	100%	100%	100%	100%	100%	100%	90%
2000	100%	100%	100%	100%	100%	100%	100%	94%	83%
1900	100%	100%	100%	100%	100%	100%	98%	86%	76%
1800	100%	100%	100%	100%	100%	100%	90%	78%	69%
1700	100%	100%	100%	100%	100%	95%	82%	71%	61%
1600	100%	100%	100%	100%	100%	85%	73%	63%	54%
1500	100%	100%	100%	100%	90%	76%	65%	55%	N.D.
1400	100%	100%	100%	96%	80%	67%	57%	N.D.	N.D.
1300	100%	100%	100%	84%	70%	58%	N.D.	N.D.	N.D.
1200	100%	100%	90%	73%	100%	N.D.	N.D.	N.D.	N.D.
1100	100%	97%	78%	62%	100%	N.D.	N.D.	N.D.	N.D.
1000	100%	83%	65%	51%	N.D.	N.D.	N.D.	N.D.	N.D.
	600	700	800	900	1000	1100	1200	1300	1400

Legenda Stringa di Prodotto / Product String Key

(1) Cat. D'Uso Cat. of Use	(2) Durabilità Durability	(3) Massa Mass	(4) Resist. Fuoco Fire Resistance	(5) Sicurezza D'Uso Safety of Use	(6) Resist. Corrosione Corrosion Resist.	(7) Effrazione Breakage	(8) Grado Degree
1= Leggero <i>Lightweigh</i>	3:10'000	2: 40Kg	0: Non Idoneo. <i>Not Suitable</i>	1: Soddisfatto. <i>Met</i>	4: 240h in nebbia salina in accordo a UNI EN 1670:2008. <i>240h in salt spray in accordance with UNI EN 1670:2008</i>	1	Valore: Combinazione di Massa e cicli. <i>Combination of Mass and Cycles</i>
2= Medio <i>Medium</i>	4:25.000	3: 60 Kg					
3= Pesante <i>Heavy</i>	7:200.000	4: 80 Kg					
4= Intenso <i>vintense</i>							



Battente una e Due Ante
Single and Double Sash Casement Window

ARTICOLO Item		PORTATA Load Capacity
ACX 08.09		100% = 80Kg
CERNIERA A PETTINE <i>Comb hinge 2Wings</i>		
ACX 08.09 + VITE		100% = 120Kg
CERNIERA A PETTINE + VITE <i>Comb hinge + Screw</i>		

In alcuni schemi sono indicate cerniere in colore blu ed è suggerita l'applicazione per finestre/porte in ambienti pubblici.
Some diagrams show blue hinges and suggest their use for windows/doors in public areas.

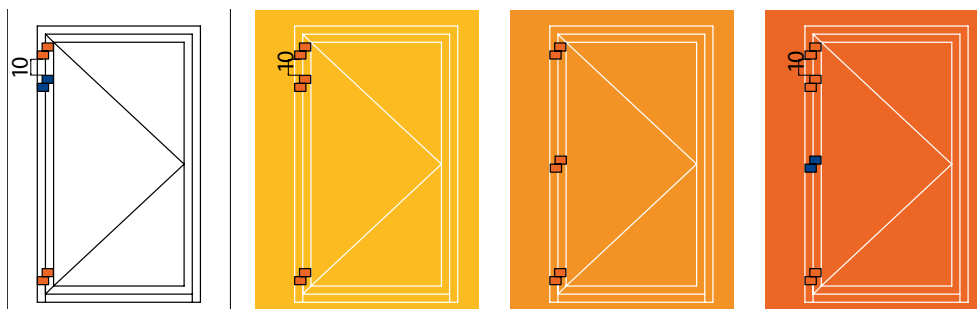

2800	100%	100%	100%	100%	100%	100%	100%	100%	100%
2700	100%	100%	100%	100%	100%	100%	100%	100%	100%
2600	100%	100%	100%	100%	100%	100%	100%	100%	100%
2500	100%	100%	100%	100%	100%	100%	100%	100%	100%
2400	100%	100%	100%	100%	100%	100%	100%	100%	100%
2300	100%	100%	100%	100%	100%	100%	100%	100%	100%
2200	100%	100%	100%	100%	100%	100%	100%	100%	97%
2100	100%	100%	100%	100%	100%	100%	100%	100%	90%
2000	100%	100%	100%	100%	100%	100%	100%	94%	83%
1900	100%	100%	100%	100%	100%	100%	98%	86%	76%
1800	100%	100%	100%	100%	100%	100%	90%	78%	69%
1700	100%	100%	100%	100%	100%	95%	82%	71%	61%
1600	100%	100%	100%	100%	100%	85%	73%	63%	54%
1500	100%	100%	100%	100%	90%	76%	65%	55%	N.D.
1400	100%	100%	100%	96%	80%	67%	57%	N.D.	N.D.
1300	100%	100%	100%	84%	70%	58%	N.D.	N.D.	N.D.
1200	100%	100%	90%	73%	100%	N.D.	N.D.	N.D.	N.D.
1100	100%	97%	78%	62%	100%	N.D.	N.D.	N.D.	N.D.
1000	100%	83%	65%	51%	N.D.	N.D.	N.D.	N.D.	N.D.
	600	700	800	900	1000	1100	1200	1300	1400

Legenda Stringa di Prodotto / Product String Key

(1) Cat. D'Uso Cat. of Use	(2) Durabilità Durability	(3) Massa Mass	(4) Resist. Fuoco Fire Resistance	(5) Sicurezza D'Uso Safety of Use	(6) Resist. Corrosione Corrosion Resist.	(7) Effrazione Breakage	(8) Grado Degree
1= Leggero <i>Lightweigh</i>	3:10'000	2: 40Kg	0: Non Idoneo. <i>Not Suitable</i>	1: Soddisfatto. <i>Met</i>	4: 240h in nebbia salina in accordo a UNI EN 1670:2008. <i>240h in salt spray in accordance with UNI EN 1670:2008</i>	1	Valore: Combinazione di Massa e cicli. <i>Combination of Mass and Cycles</i>
2= Medio <i>Medium</i>	4:25.000	3: 60 Kg					
3= Pesante <i>Heavy</i>	7:200.000	4: 80 Kg					
4= Intenso <i>vintense</i>							



Profili Porte Applicazione Esterna
Profiles for External Application

TIPO Type	ARTICOLO Item	PORTATA Load Capacity
	ARX 02.12 CERNIERA PER PORTE REGISTRABILE 2Alì <i>ADJUSTABLE HINGE FOR DOOR 2Wings</i>	 100% = 160Kg
	ARX 02.13 CERNIERA PER PORTE REGISTRABILE 3Alì <i>ADJUSTABLE HINGE FOR DOOR 3Wings</i>	
	ARX 02.13 CERNIERA PER PORTE REGISTRABILE 3Alì <i>ADJUSTABLE HINGE FOR DOOR 3Wings</i>	 100% = 200Kg
	ARX 02.12 CERNIERA PER PORTE REGISTRABILE 2Alì <i>ADJUSTABLE HINGE FOR DOOR 2Wings</i>	

In alcuni schemi sono indicate cerniere in colore blu ed è suggerita l'applicazione per finestre/porte in ambienti pubblici.
Some diagrams show blue hinges and suggest their use for windows/doors in public areas.

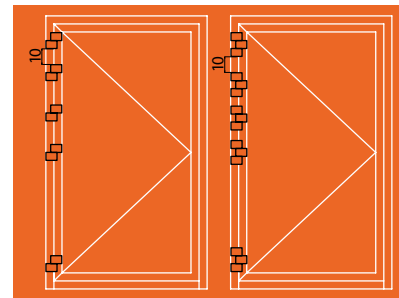
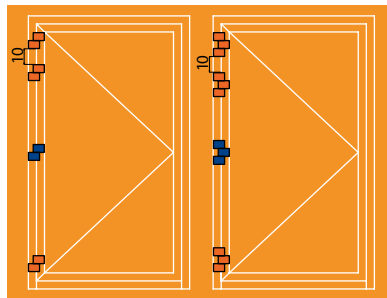
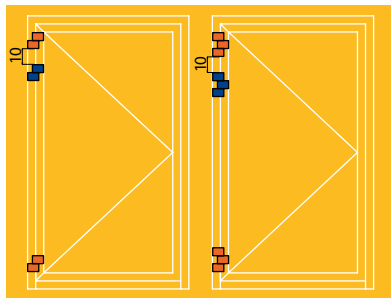



3300-4000	100%	100%	100%	100%	100%	100%	100%	100%	100%	100%	100%	100%	100%	100%	100%
3200	100%	100%	100%	100%	100%	100%	100%	100%	100%	100%	100%	100%	100%	100%	100%
3100	100%	100%	100%	100%	100%	100%	100%	100%	100%	100%	100%	100%	100%	100%	95%
3000	100%	100%	100%	100%	100%	100%	100%	100%	100%	100%	100%	100%	100%	98%	90%
2900	100%	100%	100%	100%	100%	100%	100%	100%	100%	100%	100%	100%	100%	93%	85%
2800	100%	100%	100%	100%	100%	100%	100%	100%	100%	100%	100%	100%	100%	100%	80%
2700	100%	100%	100%	100%	100%	100%	100%	100%	100%	100%	100%	99%	90%	82%	75%
2600	100%	100%	100%	100%	100%	100%	100%	100%	100%	100%	100%	93%	84%	77%	70%
2500	100%	100%	100%	100%	100%	100%	100%	100%	100%	100%	96%	87%	79%	72%	65%
2400	100%	100%	100%	100%	100%	100%	100%	100%	100%	100%	90%	81%	73%	66%	60%
2300	100%	100%	100%	100%	100%	100%	100%	100%	100%	93%	84%	75%	68%	61%	55%
2200	100%	100%	100%	100%	100%	100%	100%	100%	97%	87%	78%	69%	62%	56%	50%
2100	100%	100%	100%	100%	100%	100%	100%	100%	90%	80%	71%	64%	57%	51%	45%
2000	100%	100%	100%	100%	100%	100%	100%	94%	83%	73%	65%	58%	51%	45%	40%
1900	100%	100%	100%	100%	100%	100%	98%	86%	76%	67%	59%	52%	46%	40%	35%
1800	100%	100%	100%	100%	100%	100%	90%	78%	69%	60%	53%	46%	40%	35%	30%
1700	100%	100%	100%	100%	100%	95%	82%	71%	61%	53%	46%	40%	34%	29%	25%
1600	100%	100%	100%	100%	100%	85%	73%	63%	54%	47%	40%	34%	29%	24%	20%
1500	100%	100%	100%	100%	90%	76%	65%	55%	47%	40%	34%	28%	23%	N.D.	N.D.
1400	100%	100%	100%	96%	80%	67%	57%	48%	40%	33%	28%	22%	N.D.	N.D.	N.D.
1300	100%	100%	100%	84%	70%	58%	48%	40%	33%	27%	21%	N.D.	N.D.	N.D.	N.D.
1200	100%	100%	90%	73%	60%	49%	40%	32%	26%	20%	N.D.	N.D.	N.D.	N.D.	N.D.
1100	100%	97%	78%	62%	50%	40%	32%	25%	N.D.	N.D.	N.D.	N.D.	N.D.	N.D.	N.D.
1000	100%	83%	65%	51%	40%	31%	23%	N.D.	N.D.	N.D.	N.D.	N.D.	N.D.	N.D.	N.D.
	600	700	800	900	1000	1100	1200	1300	1400	1500	1600	1700	1800	1900	2000

Legenda Stringa di Prodotto / Product String Key

(1) Cat. D'Uso Cat. of Use	(2) Durabilità Durability	(3) Massa Mass	(4) Resist. Fuoco Fire Resistance	(5) Sicurezza D'Uso Safety of Use	(6) Resist. Corrosione Corrosion Resist.	(7) Effrazione Breakage	(8) Grado Degree
1= Leggero <i>Lightweigh</i>	3:10'000	2: 40Kg	0: Non Idoneo. <i>Not Suitable</i>	1: Soddisfatto. <i>Met</i>	4: 240h in nebbia salina in accordo a UNI EN 1670:2008. 240h in salt spray in accordance with UNI EN 1670:2008	1	Valore: Combinazione di Massa e cicli. <i>Combination of Mass and Cycles</i>
2= Medio <i>Medium</i>	4:25.000	3: 60 Kg					
3= Pesante <i>Heavy</i>	7:200.000	4: 80 Kg					
4= Intenso <i>vintense</i>							

Profili Porte Applicazione Esterna
Profiles for External Application

TIPO Type	ARTICOLO Item	PORTATA Load Capacity	VITE OBBLIGATORIA Mandatory Screw
■	ACX 08.01 KIT BASE ANTA RIBALTA WEEN <i>ATILT AND TURN KIT WEEN</i>	100% = 160Kg	 >100KG <160KG + 
	ACX 08.01L KIT BASE ANTA RIBALTA WEEN LOGICA <i>ATILT AND TURN KIT WEEN LOGICA</i>		

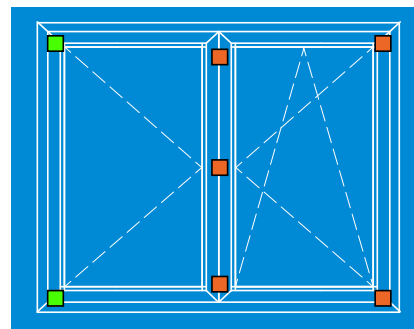
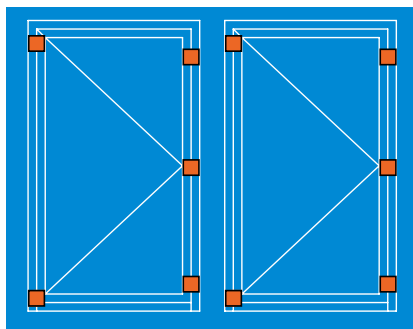

■ Negli schemi sono indicate cerniere in colore verde per anta affiancata art. **ACX.08.48**
The diagrams show green hinges for side-by-side doors - item ACX.08.48

2700	50	50	47	40	34	30	26	24	22	20	18	17	16	15	14
2600	50	50	49	41	35	31	27	25	22	21	19	18	16	15	14
2500	50	50	50	43	37	32	28	26	23	21	20	18	17	16	15
2400	50	50	50	44	38	33	30	27	24	22	21	19	18	17	16
2300	50	50	50	46	40	35	31	28	25	23	21	20	19	17	16
2200	50	50	50	48	42	36	32	29	26	24	22	21	19	18	17
2100	50	50	50	50	44	38	34	30	28	25	23	22	20	19	16
2000	50	50	50	50	46	40	36	32	29	27	25	23	21	20	17
1900	50	50	50	50	48	42	37	34	31	28	26	24	22	19	18
1800	50	50	50	50	50	44	40	36	32	30	27	25	21	20	19
1700	50	50	50	50	50	47	42	38	34	31	29	24	23	21	20
1600	50	50	50	50	50	50	44	40	36	33	28	26	24	23	18
1500	50	50	50	50	50	50	47	43	39	36	30	27	26	20	15
1400	50	50	50	50	50	50	50	46	42	34	32	29	23	17	16
1300	50	50	50	50	50	50	50	49	40	37	34	26	20	18	12
1200	50	50	50	50	50	50	50	48	44	40	31	23	21	13	6
1100	50	50	50	50	50	50	50	50	48	36	27	25	16	7x	x
1000	50	50	50	50	50	50	50	50	44	32	30	18	9x	x	x
900	50	50	50	50	50	50	50	43	39	24	11	x	x	x	x
800	50	50	50	50	50	50	50	48	29	13	x	x	x	x	x
700	50	50	50	50	50	50	50	18	x	x	x	x	x	x	x
600	50	50	50	50	50	50	24	x	x	x	x	x	x	x	x
500	50	50	50	50	50	x	x	x	x	x	x	x	x	x	x
	370	400	500	600	700	800	900	1000	1100	1200	1300	1400	1500	1600	1700

Legenda Stringa di Prodotto / Product String Key

(1) Cat. D'Uso Cat. of Use	(2) Durabilità Durability	(3) Massa Mass	(4) Resist. Fuoco Fire Resistance	(5) Sicurezza D'Uso Safety of Use	(6) Resist. Corrosione Corrosion Resist.	(7) Effrazione Breakage	(8) Grado Degree
1= Leggero <i>Lightweigh</i>	3:10'000	2: 40Kg	0: Non Idoneo. <i>Not Suitable</i>	1: Soddisfatto. <i>Met</i>	4: 240h in nebbia salina in accordo a UNI EN 1670:2008. <i>240h in salt spray in accordance with UNI EN 1670:2008</i>	1	Valore: Combinazione di Massa e cicli. <i>Combination of Mass and Cycles</i>
2= Medio <i>Medium</i>	4:25.000	3: 60 Kg					
3= Pesante <i>Heavy</i>	7:200.000	4: 80 Kg					
4= Intenso <i>vintense</i>							



LA MARCATURA CE DELLE FINESTRE E PORTE PEDONALI
[Senza caratteristiche di resistenza al fuoco e/o di tenuta al fumo]

Il marchio CE, apposto sui prodotti da costruzione, attesta la loro conformità ai requisiti essenziali definiti dalla direttiva 89/106/CE "Prodotti da costruzione", emanata dal Consiglio della Comunità Europea il 21/12/1988 ed attuata, in Italia, dal D.P.R. n. 246 del 21/04/1993. La marcatura CE di uno specifico prodotto da costruzione diviene obbligatoria, al fine di immettere il prodotto in un mercato della Comunità Europea, allorché sia stata emessa dal CEN, su mandato della Comunità Europea, una "specificazione tecnica" (norma o benessere tecnico) che regolamenti la sua applicazione.

La responsabilità per la verifica dei requisiti del prodotto e per l'apposizione della marcatura CE spetta al suo fabbricante.

Al fine di garantire i requisiti richiesti dalle relative norme, il fabbricante è tenuto a:

- ◆ Predisporre un piano di controllo della produzione (FPC). E' un sistema di procedure e controlli da eseguire durante le fasi di produzione
- ◆ Effettuare delle "prove iniziali di tipo" (ITT) sul prodotto al fine di determinare le prestazioni. Le modalità di prova dei requisiti del prodotto sono definite dalle norme richiamate dalla specifica norma prodotto".

Alcune prove possono essere eseguite dal produttore stesso, secondo le disposizioni delle relative norme armonizzate, mentre altri requisiti sono di competenza di laboratori in possesso di una notifica attribuita loro dallo stato membro di appartenenza (organismi notificati).

IL FABBRICANTE PUO' PROCEDERE IN PIU' MODI:

- ◆ Eseguire autonomamente i test sui propri prodotti presso un istituto Notificato, diventando quindi titolare degli ITT
- ◆ Far riferimento ai risultati di prove effettuate dal detentore del sistema di serramento, purché quest'ultimo abbia espresso il proprio consenso per mezzo di un contratto di licenza d'uso stipulato tra le parti.

Da Febbraio 2010 è obbligatoria la marcatura CE per finestre e porte pedonabili senza caratteristiche di resistenza al fuoco e tenuta al fumo.

L'appendice ZA della norma UNI EN 14351-1 specifica le caratteristiche essenziali per finestre e porte e attribuisce le competenze delle prove iniziali di tipo.

Il requisito relativo ad una determinata caratteristica non è applicabile in quegli Stati Membri nei quali non sussistono requisiti di regolamentazione per tale caratteristica per l'impiego previsto del prodotto. In questo caso, i fabbricanti che immettono i loro prodotti sul mercato di questi Stati membri non sono obbligati a determinare né a dichiarare le prestazioni dei loro prodotti in relazione a questa caratteristica e può essere utilizzata l'opzione "Nessuna Prestazione Determinata" (NPD) nelle informazioni che accompagnano la marcatura CE (vedere punto ZA.3). Tuttavia, l'opzione NPD non può essere utilizzata nel caso in cui la caratteristica sia soggetta a un livello soglia. (Citazione integrale tratta dalla norma UNI EN 14351-1 - appendice ZA)

CE MARKING OF PEDESTRIAN WINDOWS AND DOORS
[Without fire resistance and/or smoke resistance characteristics]

The CE marking, affixed to products, certifies their compliance with the essential requirements of Directive 89/106/EC "Construction products", issued by the Council of the European Community on 21/12/1988 and implemented, in Italy, by Presidential Decree no. 246 of 21/04/1993. The CE marking of a specific product is mandatory when the product is to be placed on a European Community market, whenever a "technical specification" (standard or technical approval) that regulates its application has been issued by CEN, under mandate of the European Community.

The manufacturer is responsible for verifying product requirements and affixing the CE marking. To ensure fulfilment of the requirements of the relevant standards, the manufacturer must:

- ◆ **Draw up a production control plan (PCP). This system of procedures and controls are performed during the production stages.**
- ◆ **Carry out "initial type tests" (ITT) on the product in order to determine performance. The test methods of the product requirements are defined by the standards referred to in the specific product standard".**

Some tests can be carried out by the manufacturer, in accordance with the provisions of the relevant harmonised standards, while others are the responsibility of laboratories awarded notified body status by their Member State (notified bodies).

THE MANUFACTURER MAY PROCEED IN SEVERAL WAYS:

- ◆ **Carry out the tests on its products independently at a Notified Body, thus becoming the holder of the ITTs**
- ◆ **Refer to the results of tests carried out by the holder of the window and door system, provided that the latter has given his consent by means of a user licence agreement signed by the parties.**

From February 2010, CE marking is mandatory for pedestrian windows and doors without fire resistance and smoke resistance characteristics.

Appendix ZA of standard UNI EN 14351-1 specifies the essential characteristics for windows and doors and attributes responsibilities for the initial type tests.

The requirement for a given characteristic does not apply in the Member States where there are no regulatory requirements for that characteristic for the intended use of the product. In this case, manufacturers who place their products on the market of these Member States shall not be obliged to determine or to declare the performance of their products for same characteristic and the "No Performance Determined" (NPD) option may be used in the information accompanying the CE marking (see point ZA.3). However, the NPD option cannot be used when the characteristic is subject to a threshold level. (Full quote from UNI EN 14351-1 - Appendix ZA)



Per finestre e porte senza funzione di compartimentazione del fuoco o fumo e non poste nelle vie di fuga (sistema di attestazione della conformità 3):

For windows and doors without a fire or smoke compartmentalization function and not located in run off areas (conformity attestation system 3):

CARATTERISTICHE FONDAMENTALI FUNDAMENTAL CHARACTERISTICS	Espressioni di Prestazione Expressions of Performance	Competenze Prove Iniziali Tipo Initial Type Test Responsibilities		
		ON= Organismo Notificato; PR= Produttore ON=Notified Body; PR= Manufacturer		
		Finestre Windows	Porte Doors	Lucernari Hopper Windows
Comportamento al FUOCO Dall'Esterno <i>External Fire Behaviour</i>				ON
Resistenza al FUOCO <i>Fire Reaction</i>	Euroclassi <i>Euroclasses</i>			ON
Tenuta all'ACQUA <i>Watertightness</i>	Classi Tecniche <i>Technical Classes</i>	ON	ON	ON
Sostanze Pericolose <i>Hazardous Substances</i>		ON	ON	
Resistenza al Carico del VENTO <i>Wind Load Resistance</i>	Classi Tecniche <i>Technical Classes</i>	ON	ON	PR
Resistenza al Carico della NEVE e Carico Permanente <i>Snow Load and Permenent Load</i>	Classi Tecniche <i>Technical Classes</i>			PR
Resistenza all'URTO <i>Shock Resistance</i>	KN/m² <i>KN/sqm</i>		PR	ON
Capacità Portante dei Dispositivi di Sicurezza <i>Load-bearing Capacity of Safety Devices</i>	Soglia <i>Threshold</i>	ON	ON	ON
Altezza <i>Height</i>	mm.		PR	
Forze di azionamento (solo dispositivi automatici) <i>Operating forces (automatic devices only)</i>	Classi Tecniche <i>Technical Classes</i>		ON	
Prestazione acustica <i>Acoustic Performance</i>	dB	ON	ON	ON
Trasmittanza termica <i>Heat Transmittance</i>	W/m²K	ON	ON	ON
Proprietà radioattive <i>Radioactive properties</i>				PR
Permeabilità all'ARIA <i>AIR Permeability</i>	Classi Tecniche <i>Technical Classes</i>	ON	ON	PR

La valutazione delle caratteristiche da dichiarare è funzione della destinazione d'uso del prodotto e della legislazione vigente nello Stato Membro, ove esso è immesso.

The characteristics to be declared depend on the intended use of the product and the legislation in force in the Member State where it is sold.



TEST INIZIALI di TIPO (ITT)

La serie riportata nel presente catalogo è stata sottoposta a test iniziali di tipo (ITT) relativamente ai requisiti previsti dalla norma prodotto UNI EN 14351-1. I risultati dei test iniziali di tipo sono estendibili a serramenti di differente tipologia e con differenti dimensioni e componenti, secondo le indicazioni fornite dalla norma EN 14351-1 in Appendice A (interdipendenza fra le caratteristiche e i componenti), Appendice E (determinazione delle caratteristiche) ed Appendice F (selezione facoltativa di provini rappresentativi per le finestre).

Il costruttore di serramenti ha la responsabilità di verificare la rispondenza del serramento prodotto rispetto al campione sottoposto a prova. Il consorzio TWIN Systems mette a disposizione dei propri clienti i risultati dei test effettuati, a seguito della stipulazione di un contratto d'uso gratuito degli stessi.

Dichiarazione di Conformità

Il fabbricante del serramento è tenuto a consegnare al committente una dichiarazione di conformità la quale, in accordo alla norma UNI EN 14351-1, deve includere :

- ◆ Nome ed indirizzo del fabbricante o del suo rappresentante autorizzato con sede nella EEA;
- ◆ Descrizione del prodotto (tipo, identificazione, impiego, ecc.) e una copia delle informazioni che accompagnano la marcatura CE;
- ◆ Disposizioni alle quali il prodotto è conforme (appendice AZ della norma prodotto UNI EN 14351-1);
- ◆ Condizioni particolari applicabili all'impiego del prodotto (per esempio disposizioni per l'impiego in determinante condizioni, ecc.);
- ◆ Nome e indirizzo del/i laboratorio/i approvato/i.
- ◆ Nome e qualifica della persona incaricata di firmare la dichiarazione per conto del fabbricante o del suo rappresentante autorizzato.

La dichiarazione e il certificato devono essere presentati nella lingua o nelle lingue ufficiali dello Stato Membro in cui il prodotto deve essere utilizzato.

Etichettatura e Marcatura

Il fabbricante deve fornire informazioni sufficienti ad assicurare la rintracciabilità del suo prodotto fornendo il collegamento fra il prodotto, il fabbricante e la produzione. Queste informazioni devono essere contenute su un'etichetta o specificate in documenti di accompagnamento nelle specifiche tecniche pubblicate dal fabbricante. Le informazioni seguenti devono accompagnare il simbolo di marcatura CE:

- ◆ Nome e indirizzo registrato o marchio di identificazione del fabbricante;
- ◆ Ultime due cifre dell'anno in cui la marcatura CE è stata applicata;
- ◆ Riferimento alla norma di prodotto (EN 14351-1);
- ◆ Descrizione del prodotto: nome generico, materiale, dimensioni, ecc. e impiego previsto;
- ◆ Informazioni sulle caratteristiche essenziali che devono essere dichiarate presentate come:
 - ◆ Valori dichiarati o livelli e/o classi;
 - ◆ NPD - "Nessuna prestazione determinata" per le caratteristiche quando è pertinente.

INITIAL TYPE TESTS (ITT)

The series in this catalogue has been subjected to initial type tests (ITT) for the requirements of product standard UNI EN 14351-1.

The results of the initial type tests can be extended to doors and windows of different types and of different sizes and compositions, according to the indications provided for by EN 14351-1 in Appendix A (interdependence between the characteristics and compositions), Appendix E (determination of characteristics) and Appendix F (optional selection of representative samples for the windows).

The door and window manufacturer is responsible for verifying compliance of the window with the sample under test. The TWIN Systems consortium makes the results of the test performed available to its customer, after the free usage agreement has been signed.

Declaration of Conformity

The window and door manufacturer must provide the customer with a declaration of conformity which, in accordance with UNI EN 14351-1, must include:

- ◆ **Name and address of the manufacturer or its authorised representative established in the EEA;**
- ◆ **Description of the product (type, identification, use, etc.) and a copy of the information accompanying the CE marking;**
- ◆ **Provisions with which the product complies (Appendix AZ of product standard UNI EN 14351-1);**
- ◆ **Special conditions applicable to the use of the product (e.g. provisions for use under certain conditions, etc.);**
- ◆ **Name and address of the approved laboratory/ies.**
- ◆ **Name and capacity of the person empowered to sign the declaration on behalf of the manufacturer or his authorised representative.**

The declaration and certificate must be done in the official language or languages of the Member State where the product is to be used.

Labelling and Marking

The manufacturer must provide sufficient information to ensure the traceability of the product providing the link between the product, the manufacturer and the production. This information must be contained on a label or specified in accompanying documents in the technical specifications published by the manufacturer. The following information must accompany the CE marking symbol:

- ◆ **Manufacturer's name and registered address or identification mark;**
- ◆ **Last two digits of the year in which the CE marking was applied;**
- ◆ **Reference to the product standard (EN 14351-1);**
- ◆ **Description of the product: generic name, material, size, etc. and intended use;**
- ◆ **Information about the essential characteristics that must be declared;**
- ◆ **Declared values or levels and/or classes;**
- ◆ **NPD - "No Performance Determined" for characteristics when relevant.**



Il simbolo della marcatura CE e le informazioni di accompagnamento devono essere apposti in modo visibile, leggibile e indelebile in una o più delle posizioni seguenti (gerarchia di preferenza del fabbricante):

Qualsiasi parte idonea del prodotto stesso, purché sia assicurata la visibilità quando si aprono le ante; Su un'etichetta attaccata; Sul suo imballaggio; Sul documento commerciale di accompagnamento.

DOCUMENTAZIONE TECNICA DI ACCOMPAGNAMENTO

Il fabbricante deve fornire informazioni su quanto segue:

- *Immagazzinaggio e movimentazione, se il fabbricante non è responsabile dell'installazione del prodotto;*
- *Requisiti e tecniche d'installazione (sul posto), se il fabbricante non è responsabile dell'installazione del prodotto (Guida UNCSAAL)*
- *Manutenzione e pulizia (Manuale Consorzio TWIN SYSTEMS)*
- *Istruzioni d'uso finali incluse le istruzioni per la sostituzione di componenti*
- *Istruzioni per l'uso in condizioni di sicurezza.*

In Italia i requisiti obbligatori per la Marcatura CE sono:

- *Permeabilità dell'aria*
- *Trasmittanza termica*
- *Proprietà radiative (Fattore solare g, Trasmissione luminosa (TV))*

In Spagna e in Portogallo i requisiti obbligatori per la Marcatura CE sono:

- *Permeabilità all'aria*
- *Tenuta all'acqua*
- *Resistenza al vento*
- *Trasmittanza termica*
- *Isolamento acustico*

The CE marking and accompanying information must be affixed in a visible, legible and indelible way in one or more of the following positions (manufacturer's hierarchy of preference):

Any suitable part of the product itself, provided that visibility is ensured when opening the doors; On an attached label; On its packaging; On the accompanying commercial document.

ACCOMPANYING TECHNICAL DOCUMENTATION

The manufacturer will provide information about:

- *Storage and handling, if the manufacturer is not responsible for the installation of the product*
- *Requirements and installation methods (on site), if the manufacturer is not responsible for the installation of the product (UNCSAAL Guide)*
- *Maintenance and cleaning (TWIN SYSTEMS Consortium Manual)*
- *Final instructions for use including instructions for replacing components;*
- *Instructions for safe use.*

In Italy, the mandatory requirements for CE marking are:

- *Air permeability*
- *Heat Transmittance*
- *Radiative properties (Solar factor g, Light transmission (TV)).*

In Spain and Portugal the mandatory requirements for CE marking are :

- *Air permeability*
- *Watertightnes*
- *Wind resistance*
- *Heat Transmittance*
- *Sound insulation*



TRASMITTANZA TERMICA DEI SERRAMENTI

HEAT TRANSMISSION OF WINDOWS

E' necessario sapere che le prescrizioni dettate dal decreto ministeriale cambiano in funzione della tipologia di intervento edilizio (nuova costruzione, ristrutturazione importante di primo oppure secondo livello, riqualificazione energetica) e si applicano ad edifici sia pubblici sia privati.

Per edifici di nuova costruzione si intendono quei fabbricati il cui titolo abilitativo sia stato richiesto dopo l'entrata in vigore del decreto.

Sono assimilati agli edifici di nuova costruzione gli edifici sottoposti a demolizione e ricostruzione, qualunque sia il titolo abilitativo necessario, e gli ampliamenti di edifici esistenti la cui nuova porzione abbia un volume lordo climatizzato superiore al 15% di quello esistente o comunque superiore a 500 m³.

Per interventi di ristrutturazione importante di primo livello si intendono quelli che interessano l'involucro edilizio con un'incidenza superiore al 50 per cento della superficie disperdente lorda complessiva dell'edificio, comprendendo anche la ristrutturazione dell'impianto termico per il servizio di climatizzazione invernale e/o estiva asservito all'intero edificio.

Per interventi di ristrutturazione importante di secondo livello si intendono quelli che interessano l'involucro edilizio con un'incidenza superiore al 25 per cento della superficie disperdente lorda complessiva dell'edificio e possono interessare l'impianto termico per il servizio di climatizzazione invernale e/o estiva.

Negli interventi di riqualificazione energetica rientrano gli interventi non riconducibili agli interventi succitati e che hanno un impatto sulla prestazione energetica dell'edificio. Rientrano quindi anche:

- Le ristrutturazioni che interessano l'involucro edilizio con un'incidenza inferiore o uguale al 25% della superficie disperdente lorda complessiva dell'edificio e/o consistono nella nuova installazione, nella ristrutturazione di un impianto termico asservito all'edificio o di altri interventi parziali, ivi compresa la sostituzione del generatore;

- Gli ampliamenti di edifici esistenti la cui nuova porzione abbia un volume lordo climatizzato inferiore o uguale al 15% di quello esistente o comunque inferiore a 500 m³.

Per gli edifici di nuova costruzione e per quelli sottoposti a ristrutturazioni di primo livello, non sono previsti specifici limiti di trasmittanza termica da rispettare per le chiusure trasparenti. Sussiste l'obbligo di rispettare limiti per quanto concerne altri parametri tecnici che connotano gli impianti, l'involucro edilizio e l'edificio nel loro complesso (per esempio coefficiente medio globale di scambio termico per trasmissione per unità di superficie disperdente HT' - area solare equivalente estiva per unità di superficie utile Asol,est/Asup utile - indice di prestazione termica utile per riscaldamento EPH,nd - indice di prestazione termica utile per il raffrescamento EPC,nd - indice di prestazione energetica globale dell'edificio EPgl,tot, ecc.) contenuti nell'Allegato A del decreto

Note that the requirements as of the ministerial decree depend on the type of construction (new construction, major first or second level renovation, energy upgrading) and apply to both public and private buildings.

New buildings are those whose building permit has been requested following the promulgation of the decree.

Buildings subject to demolition and reconstruction, irrespective of the type of building permit, and extensions to existing buildings whose new portion has a gross air-conditioned volume of more than 15% of the existing one or in any case more than 500 m³ are considered new buildings.

Major first level renovations are those affecting the building shell with an impact of more than 50% of the building's total gross dispersant surface, also including the renovation of the heating system for the winter and/or summer air conditioning service of the entire building.

For major second-level renovation interventions, those that concern the building shell with an impact of more than 25 percent of the building's total gross dispersant surface and can regard the heating plant system for the winter and/or summer air conditioning service.

Energy upgrading works include activities that are not attributable to the aforementioned activities and that have an impact on the building's energy performance. The following are therefore also included:

- *Renovations that affect the building shell with an impact of less than or equal to 25% of the building's total gross dispersant surface and/or the new installation or upgrading of the building's heating plant or other partial works, including the replacement of the generator;*

- *Extensions of existing buildings whose new portion has a gross air-conditioned volume of less than or equal to 15% of the existing one or in any case less than 500 m³.*

For new buildings and buildings undergoing first level renovations, there are no specific heat transmission limits to be respected for transparent doors. There is an obligation to respect the limits of other technical parameters that characterise the plants, shell and building as a whole (for example, average overall heat exchange coefficient for transmission by dispersant surface unit HT' - equivalent summer solar area per unit of surface area Asol,est/Asup - useful heat performance index for heating EPH,nd - heat performance index for cooling EPC,nd - overall energy performance index of the building EPgl,tot, etc.) contained in Annex A of the decree



I limiti dell'Allegato A sul coefficiente medio globale di scambio termico per trasmissione per unità di superficie disperdente HT' sono da rispettare anche per gli interventi di ristrutturazione importante di secondo livello.

Nell'ambito degli interventi di ristrutturazione importante di secondo livello e degli interventi di riqualificazione energetica sono invece da rispettare i limiti riportati nell'Appendice B del decreto relativamente:

- **Alla trasmittanza termica U_w dei serramenti** (trasparenti, opachi) e dei **cassonetti** posti a delimitazione di ambienti climatizzati verso l'esterno oppure verso ambienti non climatizzati (cfr. **tabella 1**);
- **Al fattore di trasmissione solare totale g_{gl+sh} dei serramenti vetriati in combinazione con schermature solari mobili** posizionati sui fronti dell'edificio SUD, EST, OVEST, SUD-EST, SUD-OVEST (cfr. **tabella 2**).

The limits of Annex A on the overall average coefficient of heat exchange through transmission by unit of dispersant surface HT' must also be respected for major second-level renovations.

In the case of major second level renovations and energy upgrading works, the limits set out in Appendix B of the decree must be respected for:

- **Heat transmission U_w of the windows (transparent, opaque) and shutter boxes positioned to delimit air-conditioned environments towards the outside or towards non-conditioned environments (see table 1);**
- **The total solar transmission factor g_{gl+sh} glazed windows in combination with mobile solar shields positioned on the SOUTH, EAST, WEST, SOUTH-EAST, SOUTH-WEST building façades (see table 2).**

Tabella/Table 1

Valori limite della trasmittanza U_w dei serramenti (trasparenti, opachi) e dei cassonetti posti a delimitazione di ambienti climatizzati verso l'esterno oppure verso ambienti non climatizzati.

ZONA CLIMATICA	U_w [W/m ² K]	
	2021	ECOBONUS
Zona A	3.00	2.60
Zona B	3.00	2.60
Zona C	2.00	1.75
Zona D	1.80	1.67
Zona E	1.40	1.30
Zona F	1.00	1.00

Tabella/Table 2

Valori limite del fattore di trasmissione solare totale g_{gl+sh} chiusure trasparenti in presenza di schermature solari mobili installate su fronti dell'edificio SUD, EST, OVEST, SUD-EST, SUD-OVEST

ZONA CLIMATICA CLIMATIC ZONE	g_{gl+sh}
	2021
Zone TUTTE ALL ZONES	0.35



VALUTAZIONE DELLA PRESTAZIONE TERMICA DEI SERRAMENTI

TRASMITTANZA TERMICA:

La trasmittanza termica rappresenta il parametro più significativo per la valutazione del comportamento termico di un prodotto edilizio: minore è il suo valore migliore è la prestazione termica posseduta dal componente stesso. Il calcolo semplificato della trasmittanza termica del componente finestrato U_w composta da un singolo serramento e relativo vetro (o pannello) si esegue con la formula:

EVALUATION OF THE THERMAL PERFORMANCE OF WINDOWS

HEAT TRANSMISSION:

Heat transmission is the most significant factor in the evaluation of the thermal performance of a building product: the lower its value, the higher the thermal performance of the product. *The simplified heat transmission calculation of the product glazing U_w comprising a single window and related glass (or panel) the formula is:*

$$U_w = \frac{A_g U_g + A_f U_f + l_g \emptyset_g}{A_g + A_f}$$

A_g : Area del vetro in m^2

U_g : Trasmittanza termica riferito all'area centrale della vetrata, e non include l'effetto del distanziatore del vetro lungo il bordo della vetrata stessa

A_f : Area del telaio

U_f : Trasmittanza termica del telaio applicabile in assenza della vetrata

l_g : Lunghezza del perimetro del vetro

\emptyset : Trasmittanza termica lineare concernente la conduzione di calore supplementare che avviene a causa dell'interazione tra telaio, vetri e distanziatore dei vetri in funzione delle proprietà termiche di ognuno di questi componenti e si rileva, secondo quanto precisato nell'allegato E della norma UNI EN ISO 10077-1, preferibilmente con il calcolo numerico eseguito in accordo con la norma ISO 10077-2; quando non sono disponibili i risultati di calcolo dettagliati ci si può riferire ai prospetti E.1 ed E.2 i quali indicano i valori \emptyset_g di default per le tipiche combinazioni di telai, vetri e distanziatori.

A_g : Area of the glass in m^2

U_g : Heat transmission of the central area of the window, not including the effect of the glass spacer along the edge of the window

A_f : Frame area

U_f : Heat transmission of the frame applicable in absence of the glass

l_g : Length of the perimeter of the glass

\emptyset : Linear heat transmission concerning the additional heat conduction that occurs due to the interaction between the frame, glass and spacer of the glass as a function of the thermal properties of each of these components and it is noted, as specified in Annex E of standard UNI EN ISO 10077-1, preferably with the numerical calculation performed in accordance with ISO 10077-2; when the detailed calculation results are not available you can refer to the default \emptyset for the typical combinations of frames, glass and spacers.

ESTENDIBILITÀ

L'appendice F della norma di prodotto UNI EN 14351-1 suggerisce le tipologie di serramento rappresentative e le relative estensioni, ma essendo la tabella puramente informativa, sta allo stesso produttore scegliere i campioni.

EXTENSIBILITY

Appendix F of the product standard UNI EN 14351-1 suggests the types of typical windows and their extensions, but since the table is purely informative, it is up to the manufacturer to choose the samples.

TIPO DI FINESTRA WINDOW TYPE	POSSIBILE ESTENSIONE Possible Extension
Anta FISSA <i>Fixed</i>	Finestra Battente/Ribalta <i>Tilt & Turn Window</i>
Porta Finestra ad Anta Singola (Apertura Interna o Esterna) <i>Single door window (internal or external opening)</i>	
Finestra Anta Singola con Ribalta <i>Single Sash Tilt & Turn Window</i>	
Finestra con DUE o più Porte (Apertura Interna o Esterna) Window with two or more doors (internal or external opening)	Stessa Tipologia <i>Same Type</i>
Finestra a UNA o DUE ante orizzontali scorrevoli Window with ONE or TWO horizontal sliding sashes	
Finestra con DUE Ante Scorrevoli Window with TWO Sliding Sashes	Stessa Tipologia <i>Same Type</i>
Finestra a UNA o DUE ante orizzontali scorrevoli con Ribalta Window with ONE or TWO horizontal sliding sashes with Tilt & Turn	Stessa Tipologia <i>Same Type</i>
Bilico Orizzontale o Verticale Horizontal or vertical pivoting window	Stessa Tipologia <i>Same Type</i>
Finestra a Soffietto Folding Window	Stessa Tipologia <i>Same Type</i>

La norma UNI EN 14351-1 prevede che il calcolo effettuato su di un serramento aventi dimensioni:

1230 (±25%) x 1480 (-25%)
 1480 (+25%) x 2180 (±25%)

Le analisi termiche effettuate con le misure sopra descritte, possono essere estese a tutti i serramenti di tutte le dimensioni, purché il vetro utilizzato abbia come valore di U_g uguale o inferiore a 1.9 w/m²K, altrimenti la norma delle regole di estensione dei valori calcolati sull'infisso normalizzato ad infissi di diverse dimensioni.

Ovviamente i calcoli devono essere effettuati sulle stesse tipologie di infissi e s'intende che una modifica del componente modifica la caratteristica in questione. In termini di prestazioni termiche è ovvio che andando a togliere o ad aggiungere elementi (per esempio passare da una finestra ad una anta, da una a due e così via), determina un variazione dei valori finali.

The UNI EN 14351-1 standard sets forth the calculation carried out on a window with dimensions:

1230 (±25%) x 1480 (-25%)
 1480 (+25%) x 2180 (±25%)

The thermal analyses carried out with the measurements described above can be extended to doors and windows of all sizes, provided that the glass used has a U_g value equal to or less than 1.9 w/m²K, otherwise the standard of the rules of the values calculated on the normalised frame is extended to frames of different sizes.

Obviously, the calculations must be carried out on the same types of frames, and it is understood that any modification to the component changes the characteristic in question. In terms of thermal performance, it is clear that, removing or adding elements (for example, switching from a window with one door to one with two doors, and so on) results in a change in the final values.



POSA QUALITÀ

IL MARCHIO

Il Marchio Posa Qualità Serramenti distinguerà i migliori costruttori italiani di serramenti di tutti i materiali, offrendo ai consumatori italiani uno strumento tangibile per distinguere le migliori aziende con una garanzia assicurativa post vendita sul prodotto installato fino a 10 anni.

In questo modo il costruttore di serramenti potrà qualificare al cliente non solo le prestazioni «astratte» di un serramento, bensì quelle reali, una volta installato, potrà attestare la qualificazione della propria Azienda e potrà garantire nel tempo ciò che ha venduto. Perché un Marchio rigoroso sulla Posa è l'unica forma di garanzia tangibile da offrire al consumatore.

Il progetto Marchi Posa Qualità prevede un piano di formazione che coinvolgerà tutta la filiera industriale del serramento, un Marchio che certificherà la qualità della progettazione della posa attraverso severi test di laboratorio e un Marchio che garantirà e verificherà la sua corretta esecuzione attraverso controlli a campione.

Il consorzio TWIN SYSTEMS è certificato PROGETTAZIONE Posa Qualità Serramenti dal 2020. I suoi consorziati organizzano periodicamente corsi professionali per l'acquisizione dei patentini professionali per i posatori.



POSA QUALITÀ

THE TRADEMARK

The Posa Qualità Serramenti Trademark identifies the best Italian manufacturers of windows and doors in all materials, offering Italian consumers a tangible way of identifying the best companies with an after-sales warranty on the installed product of up to 10 years.

In this way, the window manufacturer will be able to offer the customer not only a guaranteed "generic" good performance of the window, but real guarantees and, once installed, it will be able to attest the quality of the company and guarantee the products sold over time. Because guaranteed good installation is the only way offering customers peace of mind.

The Posa Qualità Brands project includes a training plan that will involve the entire window supply chain, a Brand that will certify the quality of the installation by means of strict laboratory tests and guarantee correct installation through spot checks.

The TWIN SYSTEMS Consortium has been certified Posa Qualità Serramenti DESIGN since 2020. The consortium members organise periodic training courses for installers with the award of professional licenses.

MANUALE e CATALOGO PRODOTTI TWIN SYSTEMS POSA QUALITÀ



IL MANUALE e CATALOGO PRODOTTI TWIN SYSTEMS per la POSA QUALITÀ è

- Disponibile presso le sedi dei consorziati e dei serramentisti di riferimento
- Liberamente scaricabile sul sito www.twinsystems.it nella sezione CATALOGHI

The TWIN SYSTEMS MANUAL and PRODUCT CATALOGUE for POSA QUALITÀ

- Is available from consortium members and reference window and door manufacturers
- Free download from the website www.twinsystems.it in the CATALOGUES section

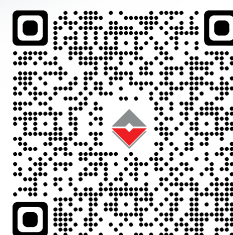

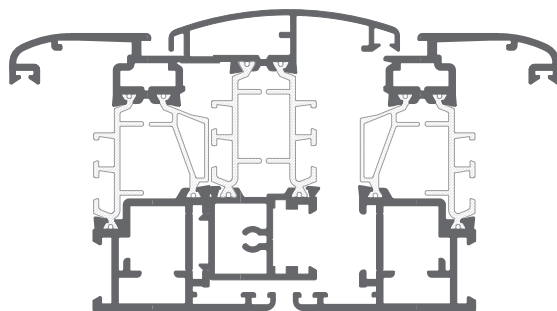
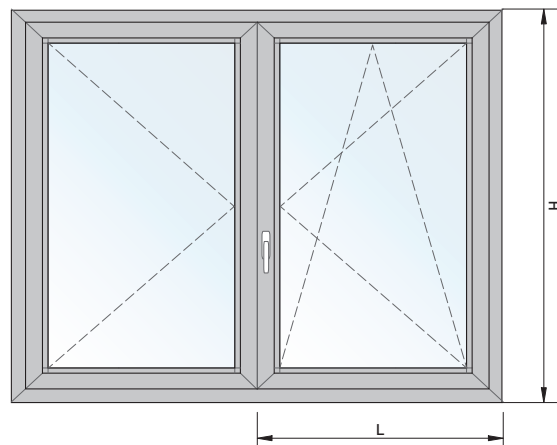
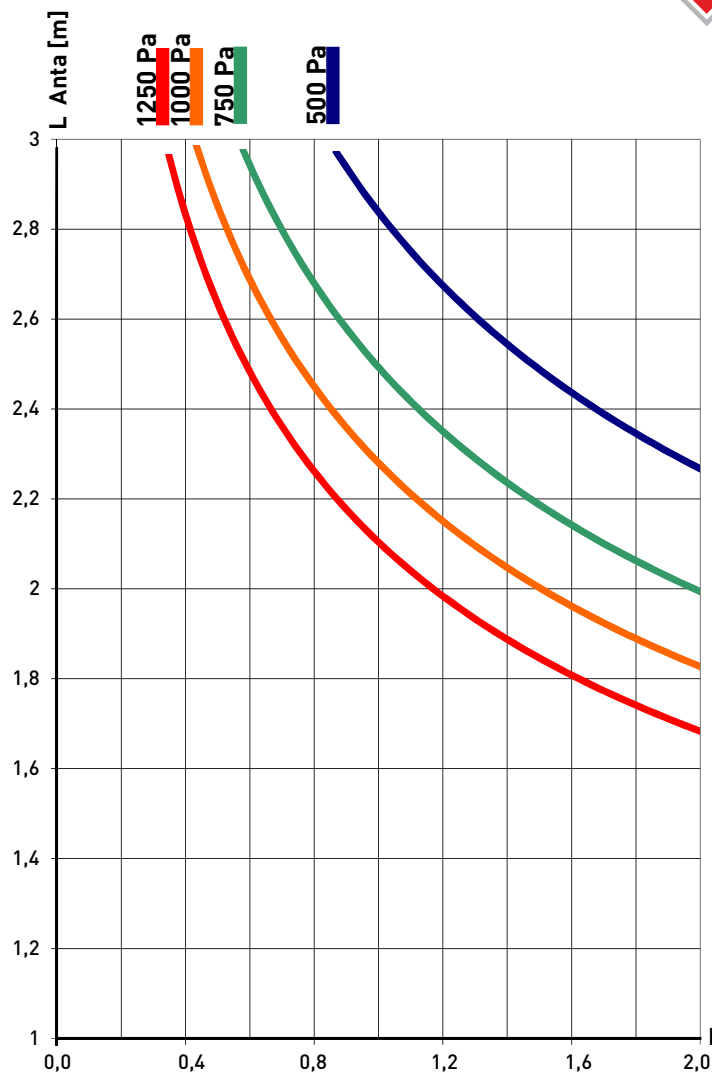

CX65.201 + CX65.301 + CX65.201

Infisso a 2 ante.
Deflessione del nodo centrale

Il dimensionamento risultante dal grafico è solo indicativo. Il progettista o il serramentista, nel determinare le dimensioni massime dei serramenti, dovrà considerare e valutare, oltre le dimensioni ed il momento d'inerzia dei profilati, anche le caratteristiche applicative e meteorologiche quali l'altezza dal suolo, l'esposizione alla pioggia e la velocità dei venti nella zona.

Per questi dati consigliamo di consultare e seguire le "Raccomandazioni UNCSAAL" elaborate sulla base delle norme UNI, UNI-EN e UNI-CNR esistenti in merito. Verificare che la freccia del profilato sia compatibile con quella del vetro utilizzato.

Le curve rappresentano la larghezza massima dell'anta in funzione della sua altezza e della pressione del vento. Il serramento è considerato a 2 ante uguali. Le curve sono calcolate sulla base della deformazione elastica di 1/300 dell'altezza del serramento.



ATTENZIONE:
Dimensionamento minimo anta L=430 H=750

Double sash windows.
Deflection of the central node

In determining the maximum dimensions of the doors and windows, in addition to the dimensions and moment of inertia of the profiles, the designer or manufacturer must also consider and evaluate the application and meteorological conditions such as the height from the ground, exposure to rain and the speed of the winds in the area.

For these data, we recommend consulting and following the "UNCSAAL Recommendations" drawn up on the basis of the relative UNI, UNI-EN and UNI-CNR standards.

Check that the arrow on the profile is compatible with the arrow on the glass used.

The curves represent the maximum width of the door as a function of its height and wind pressure. The frame is considered to have 2 doors. The curves are calculated on the basis of the elastic deformation of 1/300 of the height of the window.



ATTENZIONE:
Minimum Sash Dimension W=430 H=750

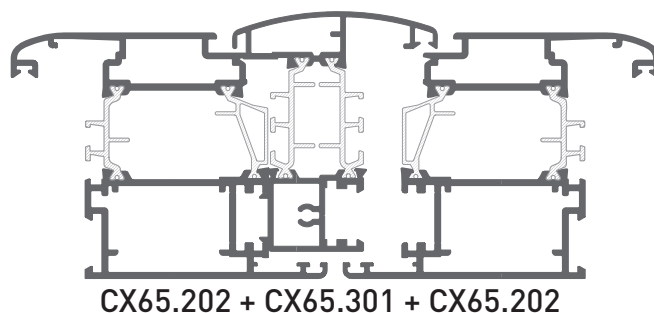
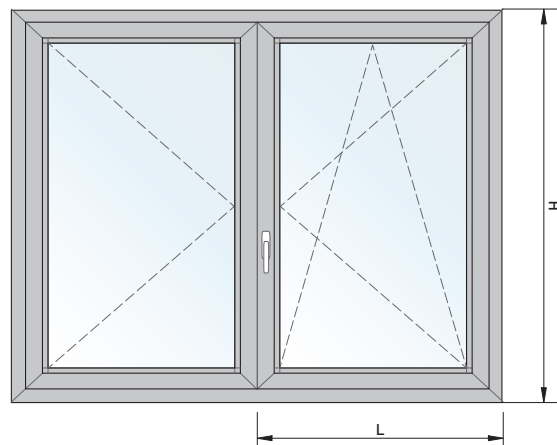
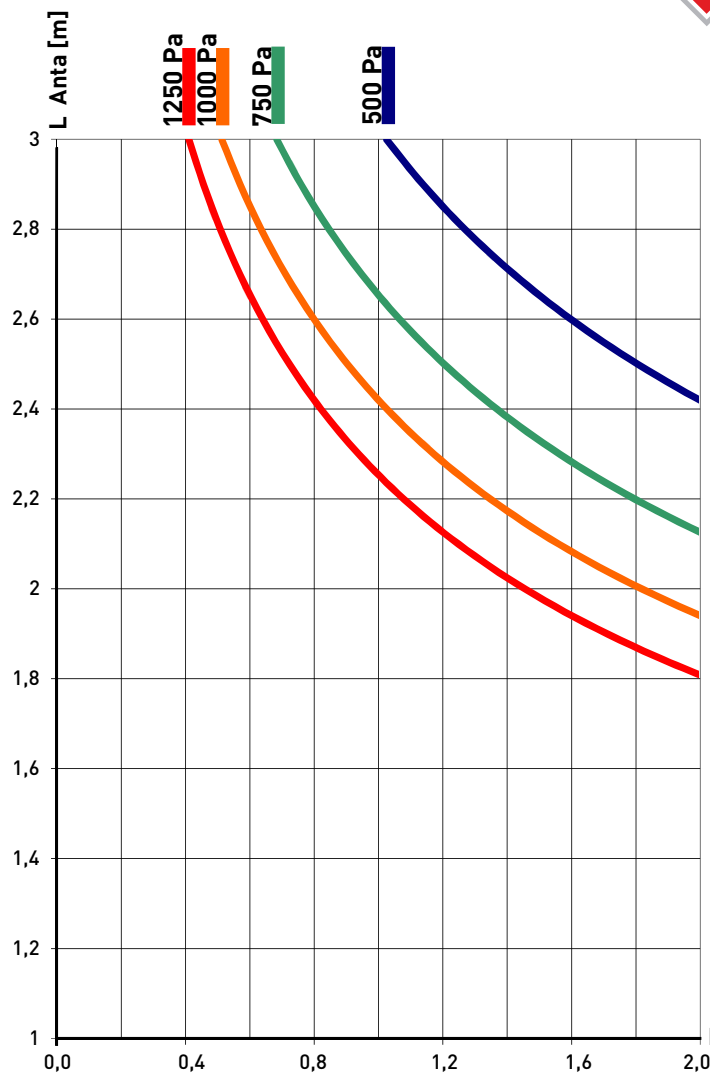

Infisso a 2 ante.
Deflessione del nodo centrale

Il dimensionamento risultante dal grafico è solo indicativo. Il progettista o il serramentista, nel determinare le dimensioni massime dei serramenti, dovrà considerare e valutare, oltre le dimensioni ed il momento d'inerzia dei profilati, anche le caratteristiche applicative e meteorologiche quali l'altezza dal suolo, l'esposizione alla pioggia e la velocità dei venti nella zona.

Per questi dati consigliamo di consultare e seguire le "Raccomandazioni UNCSAAL" elaborate sulla base delle norme UNI, UNI-EN e UNI-CNR esistenti in merito. Verificare che la freccia del profilato sia compatibile con quella del vetro utilizzato.

Le curve rappresentano la larghezza massima dell'anta in funzione della sua altezza e della pressione del vento. Il serramento è considerato a 2 ante uguali. Le curve sono calcolate sulla base della deformazione elastica di 1/300 dell'altezza del serramento.

ATTENZIONE:
Dimensionamento minimo anta L=430 H=750

Double sash windows.
Deflection of the central node

In determining the maximum dimensions of the doors and windows, in addition to the dimensions and moment of inertia of the profiles, the designer or manufacturer must also consider and evaluate the application and meteorological conditions such as the height from the ground, exposure to rain and the speed of the winds in the area.

For these data, we recommend consulting and following the "UNCSAAL Recommendations" drawn up on the basis of the relative UNI, UNI-EN and UNI-CNR standards.

Check that the arrow on the profile is compatible with the arrow on the glass used.

The curves represent the maximum width of the door as a function of its height and wind pressure. The frame is considered to have 2 doors. The curves are calculated on the basis of the elastic deformation of 1/300 of the height of the window.

ATTENZIONE:
Minimum Sash Dimension W=430 H=750

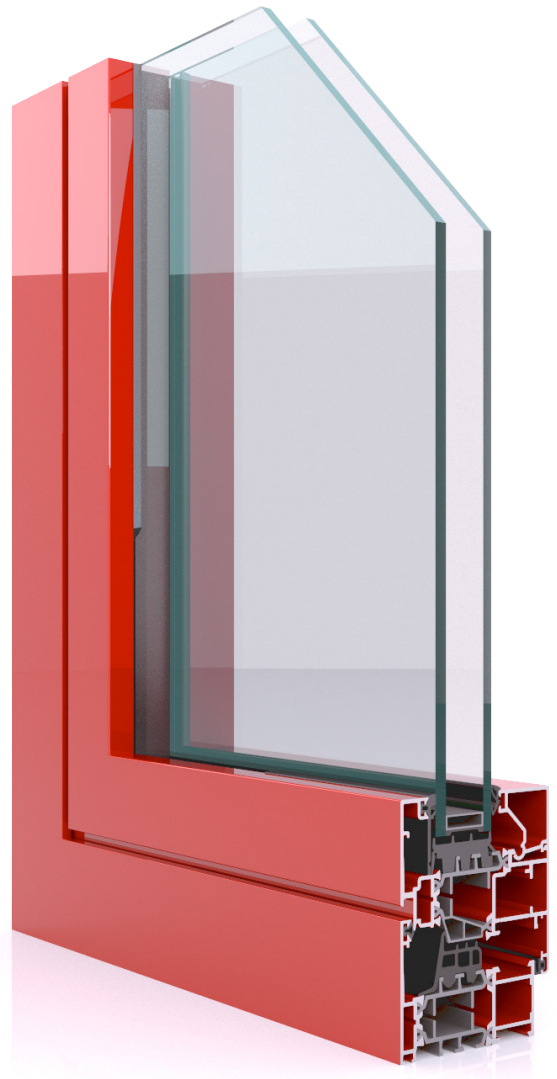

Profili
Profiles

Gruppo B

Elenco Profili
Profili Scala 1:1

Profiles List
Profiles Scale 1:1

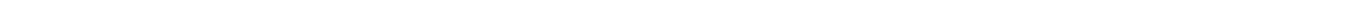

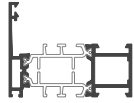
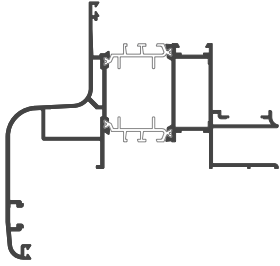
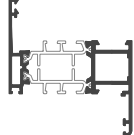
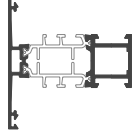
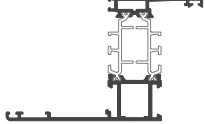
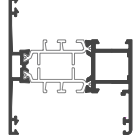
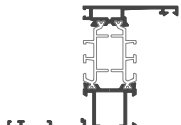
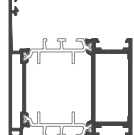
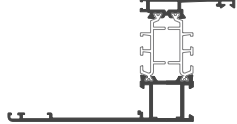
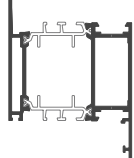
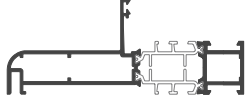
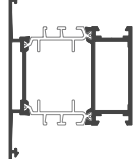
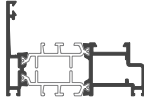
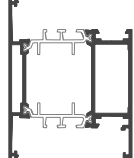
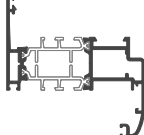

<p>CX65.101</p> <p>Telaio ad L piccolo <i>Small L Frame</i></p> <p>Peso Weight kg/ml 1.144</p> <p>Jx 21.83 cm⁴ Wx 6.28 cm³</p> <p>Jy 5.01 cm⁴ Wy 1.52 cm³</p>	 <p>Tavola Table 10</p>	<p>CX65.109</p> <p>Telaio per capannoni <i>Industrial Sheds Fr.</i></p> <p>Peso Weight kg/ml 2.958</p> <p>Jx 193.47 cm⁴ Wx 23.90 cm³</p> <p>Jy 84.84 cm⁴ Wy 11.69 cm³</p>	 <p>Tavola Table 15</p>
<p>CX65.102</p> <p>Telaio a Z piccolo <i>Small Z Frame</i></p> <p>Peso Weight kg/ml 1.254</p> <p>Jx 26.01 cm⁴ Wx 8.22 cm³</p> <p>Jy 7.67 cm⁴ Wy 2.29 cm³</p>	 <p>Tavola Table 10</p>		
<p>CX65.103</p> <p>Telaio a T piccolo <i>Small T Frame</i></p> <p>Peso Weight kg/ml 1.252</p> <p>Jx 24.96 cm⁴ Wx 6.59 cm³</p> <p>Jy 8.36 cm⁴ Wy 2.32 cm³</p>	 <p>Tavola Table 10</p>	<p>CX65.110</p> <p>Telaio a Z aletta battuta 54 mm. <i>Glazing bead Flap Z-fr. 54 mm.</i></p> <p>Peso Weight kg/ml 1.422</p> <p>Jx 30.47 cm⁴ Wx 8.08 cm³</p> <p>Jy 22.78 cm⁴ Wy 3.71 cm³</p>	 <p>Tavola Table 12</p>
<p>CX65.104</p> <p>Telaio ad H piccolo soglia <i>Low Threshold H Fr.</i></p> <p>Peso Weight kg/ml 1.362</p> <p>Jx 30.02 cm⁴ Wx 8.76 cm³</p> <p>Jy 11.01 cm⁴ Wy 2.86 cm³</p>	 <p>Tavola Table 10</p>	<p>CX65.111</p> <p>Telaio a Z aletta battuta 40 mm. <i>Glazing bead Flap Z-fr. 40 mm.</i></p> <p>Peso Weight kg/ml 1.351</p> <p>Jx 28.81 cm⁴ Wx 7.94 cm³</p> <p>Jy 14.72 cm⁴ Wy 2.92 cm³</p>	 <p>Tavola Table 12</p>
<p>CX65.105</p> <p>Telaio ad L grande <i>Big L Frame</i></p> <p>Peso Weight kg/ml 1.620</p> <p>Jx 33.51 cm⁴ Wx 10.00 cm³</p> <p>Jy 19.29 cm⁴ Wy 4.28 cm³</p>	 <p>Tavola Table 11</p>	<p>CX65.112</p> <p>Telaio a Z aletta battuta 70 mm. <i>Glazing bead Flap Z-fr. 70 mm.</i></p> <p>Peso Weight kg/ml 1.508</p> <p>Jx 32.74 cm⁴ Wx 8.26 cm³</p> <p>Jy 36.69 cm⁴ Wy 5.04 cm³</p>	 <p>Tavola Table 12</p>
<p>CX65.106</p> <p>Telaio a Z grande <i>Big Z Frame</i></p> <p>Peso Weight kg/ml 1.741</p> <p>Jx 37.61 cm⁴ Wx 11.07 cm³</p> <p>Jy 26.42 cm⁴ Wy 5.46 cm³</p>	 <p>Tavola Table 11</p>	<p>CX65.116</p> <p>Semi-pilastrino <i>Semi Pillar</i></p> <p>Peso Weight kg/ml 1.738</p> <p>Jx 92.92 cm⁴ Wx 6.49 cm³</p> <p>Jy 14.78 cm⁴ Wy 1.89 cm³</p>	 <p>Tavola Table 14</p>
<p>CX65.107</p> <p>Telaio ad T grande <i>Big T Frame</i></p> <p>Peso Weight kg/ml 1.737</p> <p>Jx 37.04 cm⁴ Wx 10.37 cm³</p> <p>Jy 26.11 cm⁴ Wy 5.43 cm³</p>	 <p>Tavola Table 11</p>	<p>CX65.119</p> <p>Tel. a L complanare piccolo <i>Small coplanar L-frame</i></p> <p>Peso Weight kg/ml 1.211</p> <p>Jx 26.75 cm⁴ Wx 6.76 cm³</p> <p>Jy 5.19 cm⁴ Wy 1.55 cm³</p>	 <p>Tavola Table 13</p>
<p>CX65.108</p> <p>Telaio ad H grande <i>Big H Frame</i></p> <p>Peso Weight kg/ml 1.858</p> <p>Jx 41.87 cm⁴ Wx 12.62 cm³</p> <p>Jy 32.21 cm⁴ Wy 6.34 cm³</p>	 <p>Tavola Table 11</p>	<p>CX65.120</p> <p>Tel. a Z compl. picc. aletta 25 mm. <i>Small coplanar Z frame flap 25 mm.</i></p> <p>Peso Weight kg/ml 1.385</p> <p>Jx 33.64 cm⁴ Wx 8.70 cm³</p> <p>Jy 11.16 cm⁴ Wy 2.93 cm³</p>	 <p>Tavola Table 13</p>



<p>CX65.121</p> <p>Tel. a Z compl. picc. aletta 40 mm. <i>Small coplanar Z-frame flap 40 mm.</i></p> <p>Peso Weight kg/ml 1.473</p> <p>Jx 36.93 cm⁴ Wx 9.02 cm³ Jy 18.94 cm⁴ Wy 3.91 cm³</p>		Tavola Table 13	<p>CX65.201</p> <p>Anta tonda Piccola c/fermavetro <i>Small round Sash w/glazing bead</i></p> <p>Peso Weight kg/ml 1.417</p> <p>Jx 33.31 cm⁴ Wx 8.72 cm³ Jy 9.92 cm⁴ Wy 2.82 cm³</p>		Tavola Table 17
<p>CX65.122</p> <p>Telaio / anta piccola <i>Frame / Small Sash</i></p> <p>Peso Weight kg/ml 1.323</p> <p>Jx 25.95 cm⁴ Wx 7.64 cm³ Jy 8.55 cm⁴ Wy 2.34 cm³</p>		Tavola Table 13	<p>CX65.202</p> <p>Anta tonda Grande c/fermavetro <i>Large round Sash w/glazing bead</i></p> <p>Peso Weight kg/ml 1.926</p> <p>Jx 46.38 cm⁴ Wx 12.27 cm³ Jy 30.74 cm⁴ Wy 6.46 cm³</p>		Tavola Table 17
<p>CX65.123</p> <p>Telaio / anta grande <i>Frame / Large Sash</i></p> <p>Peso Weight kg/ml 1.819</p> <p>Jx 36.70 cm⁴ Wx 11.05 cm³ Jy 28.12 cm⁴ Wy 5.78 cm³</p>		Tavola Table 13	<p>CX65.203</p> <p>Anta tonda Piccola v/infilare <i>Small round door glass to insert</i></p> <p>Peso Weight kg/ml 1.631</p> <p>Jx 37.23 cm⁴ Wx 9.00 cm³ Jy 15.63 cm⁴ Wy 3.99 cm³</p>		Tavola Table 18
<p>CX65.124</p> <p>Tel. L piccolo Ridotto <i>Small L. Fr. Reduced</i></p> <p>Peso Weight kg/ml 1.116</p> <p>Jx 20.50 cm⁴ Wx 6.09 cm³ Jy 4.75 cm⁴ Wy 1.47 cm³</p>		Tavola Table 16	<p>CX65.204</p> <p>Anta tonda Piccola f/nastro <i>Small round Sash tape hardware</i></p> <p>Peso Weight kg/ml 1.739</p> <p>Jx 43.12 cm⁴ Wx 11.05 cm³ Jy 15.21 cm⁴ Wy 3.93 cm³</p>		Tavola Table 17
<p>CX65.152</p> <p>Tel. bombato L piccolo <i>Small Rounded L. Fr.</i></p> <p>Peso Weight kg/ml 1.291</p> <p>Jx 30.19 cm⁴ Wx 7.42 cm³ Jy 6.82 cm⁴ Wy 2.14 cm³</p>		Tavola Table 14	<p>CX65.205</p> <p>Anta apertura Esterna <i>External opening Sash</i></p> <p>Peso Weight kg/ml 2.186</p> <p>Jx 47.85 cm⁴ Wx 11.13 cm³ Jy 36.35 cm⁴ Wy 7.30 cm³</p>		Tavola Table 23
<p>CX65.153</p> <p>Tel. bombato Z piccolo <i>Small Rounded Z. Fr.</i></p> <p>Peso Weight kg/ml 1.401</p> <p>Jx 42.01 cm⁴ Wx 11.98 cm³ Jy 15.78 cm⁴ Wy 4.61 cm³</p>		Tavola Table 14	<p>CX65.206</p> <p>Anta tonda Grande v/infilare <i>Large round door - glass to insert</i></p> <p>Peso Weight kg/ml 2.103</p> <p>Jx 50.75 cm⁴ Wx 12.58 cm³ Jy 42.73 cm⁴ Wy 8.26 cm³</p>		Tavola Table 18
<p>XX60.163</p> <p>Tel. compensazione <i>Levelling Frame</i></p> <p>Peso Weight kg/ml 1.198</p> <p>Jx 31.02 cm⁴ Wx 8.16 cm³ Jy 9.24 cm⁴ Wy 2.44 cm³</p>		Tavola Table 16	<p>CX65.207</p> <p>Anta apertura Bilico <i>Pivoting Sash</i></p> <p>Peso Weight kg/ml 2.036</p> <p>Jx 48.37 cm⁴ Wx 11.56 cm³ Jy 37.29 cm⁴ Wy 7.32 cm³</p>		Tavola Table 23
<p>CX65.172</p> <p>Tel. a Z aletta battuta 32 mm. <i>Glazing bead flap Z-frame 32 mm.</i></p> <p>Peso Weight kg/ml 1.317</p> <p>Jx 27.78 cm⁴ Wx 7.84 cm³ Jy 11.38 cm⁴ Wy 2.58 cm³</p>		Tavola Table 12	<p>CX65.209</p> <p>Anta piccola ellittica v/infilare <i>Small elliptical door glass to insert</i></p> <p>Peso Weight kg/ml 1.666</p> <p>Jx 39.40 cm⁴ Wx 09.29 cm³ Jy 16.14 cm⁴ Wy 04.16 cm³</p>		Tavola Table 18



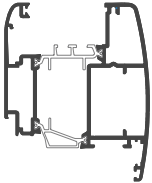
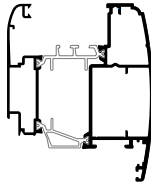
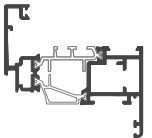
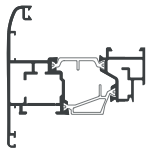
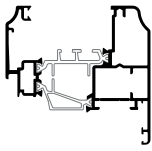
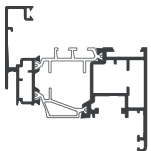
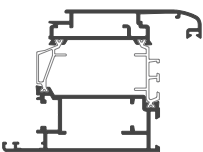
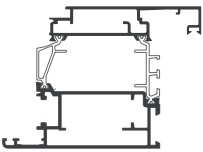
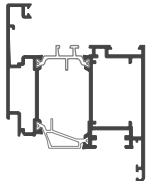
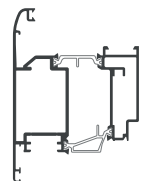
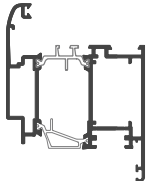
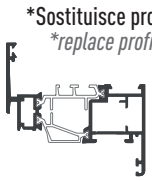
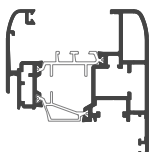
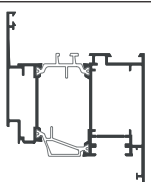
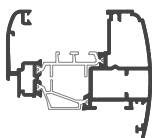
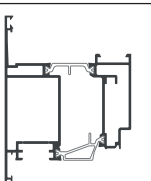



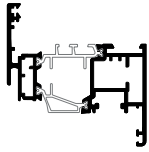
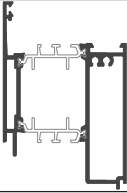
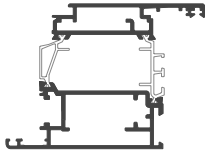
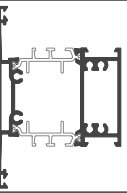
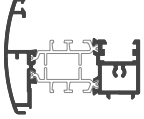
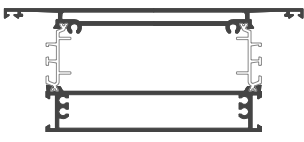
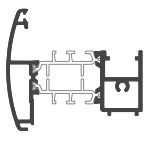
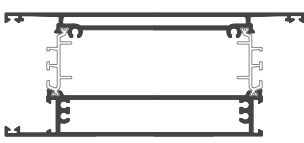
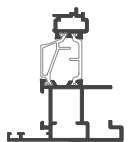
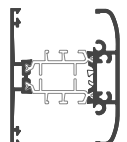
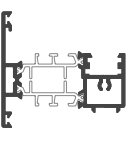
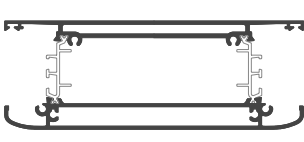
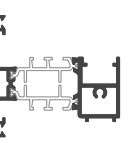
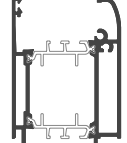
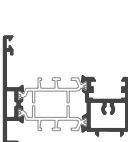
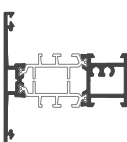



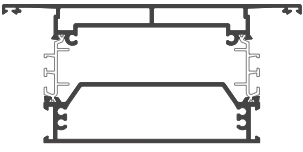

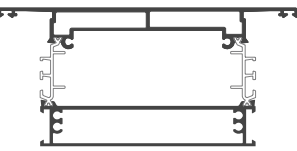

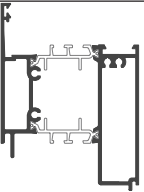

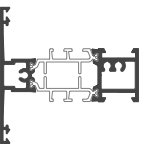
<p>CX65.210</p> <p>Anta grande ellittica v/infilare <i>Large elliptical door glass to insert</i></p> <p>Peso Weight kg/ml 2.140</p> <p>Jx 53.83 cm⁴ Wx 13.03 cm³ Jy 43.73 cm⁴ Wy 08.47 cm³</p>		<p>Tavola Table 18</p>	<p>CX65.233</p> <p>Anta grande ornamentale v/infilare <i>Large ornamental door - glass to insert</i></p> <p>Peso Weight kg/ml 2.168</p> <p>Jx 55.54 cm⁴ Wx 13.30 cm³ Jy 45.00 cm⁴ Wy 08.72 cm³</p>		<p>Tavola Table 19</p>
<p>CX65.215</p> <p>Anta dritta piccola c/fermavetro <i>Small straight Sash w/glazing bead</i></p> <p>Peso Weight kg/ml 1.438</p> <p>Jx 34.47 cm⁴ Wx 09.18 cm³ Jy 10.77 cm⁴ Wy 03.02 cm³</p>		<p>Tavola Table 20</p>	<p>CX65.237</p> <p>Anta piccola ap. ext. <i>Small ext. op. Sash</i></p> <p>Peso Weight kg/ml 1.650</p> <p>Jx 35.75 cm⁴ Wx 8.18 cm³ Jy 13.14 cm⁴ Wy 3.47 cm³</p>		<p>Tavola Table 21</p>
<p>CX65.224</p> <p>Anta piccola v/infilare <i>small sash glass to insert</i></p> <p>Peso Weight kg/ml 1.678</p> <p>Jx 42.08 cm⁴ Wx 10.87 cm³ Jy 18.59 cm⁴ Wy 4.87 cm³</p>		<p>Tavola Table 19</p>	<p>CX65.238</p> <p>Anta dritta piccola f/nastro <i>Small straight Sash tape hardware</i></p> <p>Peso Weight kg/ml 1.760</p> <p>Jx 44.37 cm⁴ Wx 11.53 cm³ Jy 16.27 cm⁴ Wy 4.15 cm³</p>		<p>Tavola Table 20</p>
<p>CX65.225</p> <p>Anta tonda grande f/nastro <i>Large round Sash tape hardware</i></p> <p>Peso Weight kg/ml 2.315</p> <p>Jx 60.61 cm⁴ Wx 16.00 cm³ Jy 50.34 cm⁴ Wy 9.46 cm³</p>		<p>Tavola Table 21</p>	<p>CX65.262</p> <p>Anta dritta grande f/nastro <i>Large straight Sash tape hardware</i></p> <p>Peso Weight kg/ml 2.337</p> <p>Jx 61.90 cm⁴ Wx 15.46 cm³ Jy 52.43 cm⁴ Wy 9.75 cm³</p>		<p>Tavola Table 20</p>
<p>CX65.226</p> <p>Anta dritta grande c/fermavetro <i>Large straight Sash w/glazing bead</i></p> <p>Peso Weight kg/ml 1.954</p> <p>Jx 47.83 cm⁴ Wx 12.85 cm³ Jy 32.29 cm⁴ Wy 06.74 cm³</p>		<p>Tavola Table 20</p>	<p>CX65.274</p> <p>Anta tonda grande ap. ext. <i>Large round Sash Ext. op.</i></p> <p>Peso Weight kg/ml 2.110</p> <p>Jx 49.69 cm⁴ Wx 11.97 cm³ Jy 38.34 cm⁴ Wy 7.57 cm³</p>		<p>Tavola Table 23</p>
<p>CX65.227</p> <p>Anta doppia battuta grande <i>Large double panelled Sash</i></p> <p>Peso Weight kg/ml 1.941</p> <p>Jx 46.76 cm⁴ Wx 12.44 cm³ Jy 31.08 cm⁴ Wy 6.58 cm³</p>		<p>Tavola Table 17</p>	<p>CX65.275</p> <p>Anta dritta rientro 5 mm. <i>Straight Sash recess 5 mm.</i></p> <p>Peso Weight kg/ml 1.401</p> <p>Jx 33.62 cm⁴ Wx 8.78 cm³ Jy 08.62 cm⁴ Wy 2.41 cm³</p>	<p>*Sostituisce prof. CX65.235 *replace profile CX65.235</p> 	<p>Tavola Table 22</p>
<p>CX65.230</p> <p>Anta tonda f/nastro <i>Round Sash tape hardware</i></p> <p>Peso Weight kg/ml 1.968</p> <p>Jx 49.04 cm⁴ Wx 11.50 cm³ Jy 22.66 cm⁴ Wy 5.29 cm³</p>		<p>Tavola Table 19</p>	<p>CX65.276</p> <p>Anta dritta grande rientro 5 mm. <i>Large straight Sash recess 5 mm.</i></p> <p>Peso Weight kg/ml 1.896</p> <p>Jx 46.92 cm⁴ Wx 12.43 cm³ Jy 28.60 cm⁴ Wy 5.96 cm³</p>		<p>Tavola Table 22</p>
<p>CX65.232</p> <p>Anta picc. ornamentale v/infilare <i>Small ornamental door glass to insert</i></p> <p>Peso Weight kg/ml 1.681</p> <p>Jx 40.55 cm⁴ Wx 09.44 cm³ Jy 16.55 cm⁴ Wy 04.26 cm³</p>		<p>Tavola Table 19</p>	<p>CX65.277</p> <p>Anta rientro 7 mm. f/nastro <i>Sash recess 7 mm. tape hardware</i></p> <p>Peso Weight kg/ml 2.102</p> <p>Jx 52.28 cm⁴ Wx 13.13 cm³ Jy 47.89 cm⁴ Wy 9.28 cm³</p>		<p>Tavola Table 23</p>

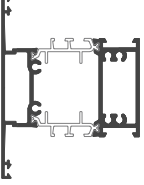

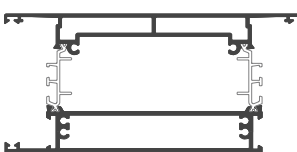
<p>CX65.278</p> <p>Anta rientro 7 mm. f/nastro Sash recess 7 mm. tape hardware</p> <p>Peso Weight kg/ml 1.766</p> <p>Jx 45.86 cm⁴ Wx 12.14 cm³</p> <p>Jy 14.64 cm⁴ Wy 3.75 cm³</p>		<p>Tavola Table</p> <p>22</p>	<p>CX65.401</p> <p>Soprazzoccolo Over Sill</p> <p>Peso Weight kg/ml 1.873</p> <p>Jx 39.72 cm⁴ Wx 11.99 cm³</p> <p>Jy 37.17 cm⁴ Wy 7.31 cm³</p>		<p>Tavola Table</p> <p>26</p>
<p>CX65.279</p> <p>Anta rientro Grande 7 mm. f/nastro Large Sash recess 7 mm. tape hardware</p> <p>Peso Weight kg/ml 2.325</p> <p>Jx 62.57 cm⁴ Wx 16.64 cm³</p> <p>Jy 49.98 cm⁴ Wy 9.39 cm³</p>		<p>Tavola Table</p> <p>22</p>	<p>CX65.402</p> <p>Traverso 96 mm. Crosspiece 96 mm.</p> <p>Peso Weight kg/ml 1.976</p> <p>Jx 40.01 cm⁴ Wx 11.28 cm³</p> <p>Jy 27.99 cm⁴ Wy 5.81 cm³</p>		<p>Tavola Table</p> <p>25</p>
<p>CX65.301</p> <p>Riparto tondo Round wing</p> <p>Peso Weight kg/ml 1.379</p> <p>Jx 29.99 cm⁴ Wx 7.95 cm³</p> <p>Jy 7.72 cm⁴ Wy 2.17 cm³</p>		<p>Tavola Table</p> <p>24</p>	<p>CX65.403</p> <p>Fascia 158 mm. Band 158 mm.</p> <p>Peso Weight kg/ml 3.048</p> <p>Jx 72.59 cm⁴ Wx 20.44 cm³</p> <p>Jy 179.67 cm⁴ Wy 22.74 cm³</p>		<p>Tavola Table</p> <p>27</p>
<p>CX65.302</p> <p>Riparto tondo f/nastro Round wing tape Hardware</p> <p>Peso Weight kg/ml 1.442</p> <p>Jx 32.19 cm⁴ Wx 8.63 cm³</p> <p>Jy 8.86 cm⁴ Wy 2.41 cm³</p>		<p>Tavola Table</p> <p>24</p>	<p>CX65.404</p> <p>Zoccolo 158 mm. Sill 158 mm.</p> <p>Peso Weight kg/ml 3.265</p> <p>Jx 77.03 cm⁴ Wx 22.42 cm³</p> <p>Jy 198.61 cm⁴ Wy 24.40 cm³</p>		<p>Tavola Table</p> <p>27</p>
<p>CX65.303</p> <p>Riparto bilico reverse pivoting</p> <p>Peso Weight kg/ml 1.253</p> <p>Jx 22.28 cm⁴ Wx 4.97 cm³</p> <p>Jy 7.07 cm⁴ Wy 2.17 cm³</p>		<p>Tavola Table</p> <p>25</p>	<p>CX65.405</p> <p>Traverso v/infilare 72 mm. Crosspiece glass to insert 72 mm.</p> <p>Peso Weight kg/ml 1.574</p> <p>Jx 27.61 cm⁴ Wx 8.65 cm³</p> <p>Jy 16.94 cm⁴ Wy 4.70 cm³</p>		<p>Tavola Table</p> <p>30</p>
<p>CX65.304</p> <p>Riparto dritto Straight wing</p> <p>Peso Weight kg/ml 1.298</p> <p>Jx 25.76 cm⁴ Wx 07.33 cm³</p> <p>Jy 06.90 cm⁴ Wy 01.97 cm³</p>		<p>Tavola Table</p> <p>24</p>	<p>CX65.406</p> <p>Traverso v/infilare 158 mm. Crosspiece glass to insert 158 mm.</p> <p>Peso Weight kg/ml 3.193</p> <p>Jx 62.21 cm⁴ Wx 21.41 cm³</p> <p>Jy 218.96 cm⁴ Wy 27.71 cm³</p>		<p>Tavola Table</p> <p>30</p>
<p>CX65.308</p> <p>Riparto dritto f/nastro Straight wing tape Hardware</p> <p>Peso Weight kg/ml 1.389</p> <p>Jx 28.71 cm⁴ Wx 8.10 cm³</p> <p>Jy 8.11 cm⁴ Wy 2.25 cm³</p>		<p>Tavola Table</p> <p>24</p>	<p>CX65.407</p> <p>Soprazzoccolo v/infilare 74 mm. Over Sill glass to insert 74 mm.</p> <p>Peso Weight kg/ml 1.736</p> <p>Jx 30.74 cm⁴ Wx 10.46 cm³</p> <p>Jy 27.79 cm⁴ Wy 6.63 cm³</p>		<p>Tavola Table</p> <p>30</p>
<p>CX65.312</p> <p>Riparto dritto Giunto Aperto Straight wing open Joint</p> <p>Peso Weight kg/ml 1.308</p> <p>Jx 29.36 cm⁴ Wx 7.91 cm³</p> <p>Jy 8.81 cm⁴ Wy 2.46 cm³</p>		<p>Tavola Table</p> <p>25</p>	<p>CX65.408</p> <p>Traverso piccolo 72 mm. Small Crosspiece 72 mm.</p> <p>Peso Weight kg/ml 1.340</p> <p>Jx 26.29 cm⁴ Wx 7.50 cm³</p> <p>Jy 8.53 cm⁴ Wy 2.34 cm³</p>		<p>Tavola Table</p> <p>28</p>

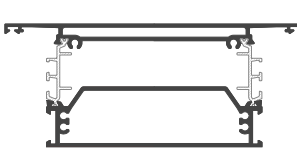

<p>CX65.409</p> <p>Soglia bassa <i>Low Threshold</i></p> <p>Peso Weight kg/ml 0.964</p> <p>Jx 14.85 cm⁴ Wx 4.33 cm³</p> <p>Jy 8.39 cm⁴ Wy 0.51 cm³</p>		<p>Tavola Table 13</p>	<p>CX65.434</p> <p>Fascia compl. da 78x158 mm. <i>Complementary Sash 78x158 mm.</i></p> <p>Peso Weight kg/ml 3.314</p> <p>Jx 89.83 cm⁴ Wx 26.97 cm³</p> <p>Jy 252.81 cm⁴ Wy 31.80 cm³</p>		<p>Tavola Table 29</p>
<p>CX65.414</p> <p>Soglia bassa per porte <i>Door Low Threshold</i></p> <p>Peso Weight kg/ml 0.839</p> <p>Jx 10.19 cm⁴ Wx 2.84 cm³</p> <p>Jy 0.61 cm⁴ Wy 0.68 cm³</p>		<p>Tavola Table 27</p>	<p>CX65.435</p> <p>Soglia bassa per porte con guarnizione <i>Door Low Threshold with gasket</i></p> <p>Peso Weight kg/ml 0.920</p> <p>Jx 14.85 cm⁴ Wx 5.19 cm³</p> <p>Jy 1.26 cm⁴ Wy 1.52 cm³</p>		<p>Tavola Table 27</p>
<p>CX65.415</p> <p>Fascia compl. da 78x158 mm. <i>Complementary Sash 78x158 mm.</i></p> <p>Peso Weight kg/ml 3.146</p> <p>Jx 90.90 cm⁴ Wx 23.59 cm³</p> <p>Jy 185.49 cm⁴ Wy 23.47 cm³</p>		<p>Tavola Table 28</p>	<p>XX70.503</p> <p>Coprifilo <i>Casing Profile</i></p> <p>Peso Weight kg/ml 0.224</p> <p>Jx 00.00 cm⁴ Wx 00.00 cm³</p> <p>Jy 00.00 cm⁴ Wy 00.00 cm³</p>		<p>Tavola Table 33</p>
<p>CX65.428</p> <p>Soprazzoccolo Anta Rientro 5 mm. <i>Door Over Sill recess 5 mm.</i></p> <p>Peso Weight kg/ml 2.048</p> <p>Jx 51.05 cm⁴ Wx 13.90 cm³</p> <p>Jy 37.12 cm⁴ Wy 7.32 cm³</p>		<p>Tavola Table 26</p>	<p>XX70.504</p> <p>Coprifilo <i>Casing Profile</i></p> <p>Peso Weight kg/ml 0.238</p> <p>Jx 00.00 cm⁴ Wx 00.00 cm³</p> <p>Jy 00.00 cm⁴ Wy 00.00 cm³</p>		<p>Tavola Table 33</p>
<p>CX65.429</p> <p>Traverso 72 mm. Anta Rientro 5 mm. <i>Crosspiece 72 mm. door recess 5 mm.</i></p> <p>Peso Weight kg/ml 1.486</p> <p>Jx 36.68 cm⁴ Wx 9.00 cm³</p> <p>Jy 8.94 cm⁴ Wy 2.45 cm³</p>		<p>Tavola Table 26</p>	<p>XX70.521</p> <p>Fermavetro tondo 14 mm. <i>Round glazing bead 14 mm.</i></p> <p>Peso Weight kg/ml 0.266</p> <p>Jx 00.00 cm⁴ Wx 00.00 cm³</p> <p>Jy 00.00 cm⁴ Wy 00.00 cm³</p>		<p>Tavola Table 39</p>
<p>CX65.430</p> <p>Traverso 96 mm. Anta Rientro 5 mm. <i>Crosspiece 96 mm. door recess 5 mm.</i></p> <p>Peso Weight kg/ml 2.022</p> <p>Jx 51.92 cm⁴ Wx 13.29 cm³</p> <p>Jy 30.03 cm⁴ Wy 6.22 cm³</p>		<p>Tavola Table 26</p>	<p>CX70.522</p> <p>Fermavetro tondo 18 mm. <i>Round glazing bead 18 mm.</i></p> <p>Peso Weight kg/ml 0.277</p> <p>Jx 00.00 cm⁴ Wx 00.00 cm³</p> <p>Jy 00.00 cm⁴ Wy 00.00 cm³</p>		<p>Tavola Table 39</p>
<p>CX65.432</p> <p>Zoccolo 158 mm. Anta Rientro 5 mm. <i>Sill 158 mm. door recess 5 mm.</i></p> <p>Peso Weight kg/ml 3.363</p> <p>Jx 93.07 cm⁴ Wx 25.39 cm³</p> <p>Jy 193.44 cm⁴ Wy 23.68 cm³</p>		<p>Tavola Table 28</p>	<p>CX70.523</p> <p>Fermavetro tondo 22 mm. <i>Round glazing bead 22 mm.</i></p> <p>Peso Weight kg/ml 0.294</p> <p>Jx 00.00 cm⁴ Wx 00.00 cm³</p> <p>Jy 00.00 cm⁴ Wy 00.00 cm³</p>		<p>Tavola Table 39</p>
<p>CX65.433</p> <p>Fascia 158 mm. <i>Sill 158 mm.</i></p> <p>Peso Weight kg/ml 3.216</p> <p>Jx 69.54 cm⁴ Wx 24.06 cm³</p> <p>Jy 240.27 cm⁴ Wy 30.04 cm³</p>		<p>Tavola Table 29</p>	<p>CX70.524</p> <p>Fermavetro tondo 26 mm. <i>Round glazing bead 26 mm.</i></p> <p>Peso Weight kg/ml 0.314</p> <p>Jx 00.00 cm⁴ Wx 00.00 cm³</p> <p>Jy 00.00 cm⁴ Wy 00.00 cm³</p>		<p>Tavola Table 39</p>









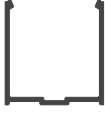

<p>CX70.525</p> <p>Fermavetro tondo 30 mm. <i>Round glazing bead 30 mm.</i></p> <p>Peso Weight kg/ml 0.350</p> <p>Jx 00.00 cm⁴ Wx 00.00 cm³</p> <p>Jy 00.00 cm⁴ Wy 00.00 cm³</p>		Tavola Table 39	<p>CX70.533</p> <p>Fermavetro dritto 5 mm. <i>Straight glazing bead 5 mm.</i></p> <p>Peso Weight kg/ml 0.252</p> <p>Jx cm⁴ Wx cm³</p> <p>Jy cm⁴ Wy cm³</p>		Tavola Table 40
<p>CX70.526</p> <p>Fermavetro dritto 14 mm. <i>Straight glazing bead 14 mm.</i></p> <p>Peso Weight kg/ml 0.279</p> <p>Jx 00.00 cm⁴ Wx 00.00 cm³</p> <p>Jy 00.00 cm⁴ Wy 00.00 cm³</p>		Tavola Table 40	<p>CX70.537</p> <p>Fermavetro dritto 40 mm. <i>Straight glazing bead 40 mm.</i></p> <p>Peso Weight kg/ml 0.403</p> <p>Jx 00.00 cm⁴ Wx 00.00 cm³</p> <p>Jy 00.00 cm⁴ Wy 00.00 cm³</p>		Tavola Table 40
<p>CX70.527</p> <p>Fermavetro dritto 18 mm. <i>Straight glazing bead 18 mm.</i></p> <p>Peso Weight kg/ml 0.290</p> <p>Jx 00.00 cm⁴ Wx 00.00 cm³</p> <p>Jy 00.00 cm⁴ Wy 00.00 cm³</p>		Tavola Table 40	<p>CX70.539</p> <p>Fermavetro dritto 10 mm. <i>Straight glazing bead 10 mm.</i></p> <p>Peso Weight kg/ml 0.245</p> <p>Jx 00.00 cm⁴ Wx 00.00 cm³</p> <p>Jy 00.00 cm⁴ Wy 00.00 cm³</p>		Tavola Table 40
<p>CX70.528</p> <p>Fermavetro dritto 22 mm. <i>Straight glazing bead 22 mm.</i></p> <p>Peso Weight kg/ml 0.307</p> <p>Jx 00.00 cm⁴ Wx 00.00 cm³</p> <p>Jy 00.00 cm⁴ Wy 00.00 cm³</p>		Tavola Table 40	<p>CX70.540</p> <p>Fermavetro dritto 10 mm. <i>Straight glazing bead 10 mm.</i></p> <p>Peso Weight kg/ml 0.249</p> <p>Jx 00.00 cm⁴ Wx 00.00 cm³</p> <p>Jy 00.00 cm⁴ Wy 00.00 cm³</p>		Tavola Table 39
<p>CX70.529</p> <p>Fermavetro dritto 26 mm. <i>Straight glazing bead 26 mm.</i></p> <p>Peso Weight kg/ml 0.327</p> <p>Jx 00.00 cm⁴ Wx 00.00 cm³</p> <p>Jy 00.00 cm⁴ Wy 00.00 cm³</p>		Tavola Table 40	<p>CX70.562</p> <p>Fermavetro Sicurezza 14 mm. <i>Safety glazing bead 14 mm.</i></p> <p>Peso Weight kg/ml 0.309</p> <p>Jx 00.00 cm⁴ Wx 00.00 cm³</p> <p>Jy 00.00 cm⁴ Wy 00.00 cm³</p>		Tavola Table 41
<p>CX70.530</p> <p>Fermavetro dritto 30 mm. <i>Straight glazing bead 30 mm.</i></p> <p>Peso Weight kg/ml 0.362</p> <p>Jx 00.00 cm⁴ Wx 00.00 cm³</p> <p>Jy 00.00 cm⁴ Wy 00.00 cm³</p>		Tavola Table 40	<p>CX70.563</p> <p>Fermavetro Sicurezza 18 mm. <i>Safety glazing bead 18 mm.</i></p> <p>Peso Weight kg/ml 0.331</p> <p>Jx 00.00 cm⁴ Wx 00.00 cm³</p> <p>Jy 00.00 cm⁴ Wy 00.00 cm³</p>		Tavola Table 41
<p>CX70.531</p> <p>Fermavetro tondo 35 mm. <i>Round glazing bead 35 mm.</i></p> <p>Peso Weight kg/ml 0.370</p> <p>Jx 00.00 cm⁴ Wx 00.00 cm³</p> <p>Jy 00.00 cm⁴ Wy 00.00 cm³</p>		Tavola Table 39	<p>CX70.564</p> <p>Fermavetro Sicurezza 22 mm. <i>Safety glazing bead 22 mm.</i></p> <p>Peso Weight kg/ml 0.349</p> <p>Jx 00.00 cm⁴ Wx 00.00 cm³</p> <p>Jy 00.00 cm⁴ Wy 00.00 cm³</p>		Tavola Table 41
<p>CX70.532</p> <p>Fermavetro dritto 35 mm. <i>Straight glazing bead 35 mm.</i></p> <p>Peso Weight kg/ml 0.383</p> <p>Jx 00.00 cm⁴ Wx 00.00 cm³</p> <p>Jy 00.00 cm⁴ Wy 00.00 cm³</p>		Tavola Table 40	<p>CX70.565</p> <p>Fermavetro Sicurezza 26 mm. <i>Safety glazing bead 26 mm.</i></p> <p>Peso Weight kg/ml 0.374</p> <p>Jx 00.00 cm⁴ Wx 00.00 cm³</p> <p>Jy 00.00 cm⁴ Wy 00.00 cm³</p>		Tavola Table 41

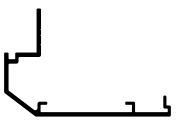
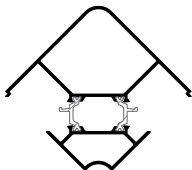
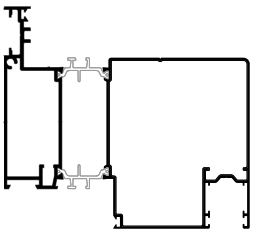

<p>CX70.566</p> <p>Fermavetro Sicurezza 30 mm. <i>Safety glazing bead 30 mm.</i></p> <p>Peso Weight kg/ml 0.400</p> <p>Jx 00.00 cm⁴ Wx 00.00 cm³</p> <p>Jy 00.00 cm⁴ Wy 00.00 cm³</p>		Tavola Table 41	<p>CX70.581</p> <p>Fermavetro Clips Tondo 35 mm. <i>Round glazing bead Clips 35 mm.</i></p> <p>Peso Weight kg/ml 0.375</p> <p>Jx 00.00 cm⁴ Wx 00.00 cm³</p> <p>Jy 00.00 cm⁴ Wy 00.00 cm³</p>		Tavola Table 42
<p>CX70.567</p> <p>Fermavetro Sicurezza 35 mm. <i>Safety glazing bead 35 mm.</i></p> <p>Peso Weight kg/ml 0.436</p> <p>Jx 00.00 cm⁴ Wx 00.00 cm³</p> <p>Jy 00.00 cm⁴ Wy 00.00 cm³</p>		Tavola Table 41	<p>XX70.601</p> <p>Gocciolatoio Drip Tray</p> <p>Peso Weight kg/ml 0.270</p> <p>Jx 00.00 cm⁴ Wx 00.00 cm³</p> <p>Jy 00.00 cm⁴ Wy 00.00 cm³</p>		Tavola Table 33
<p>CX70.568</p> <p>Fermavetro Sicurezza 10 mm. <i>Safety glazing bead 10 mm.</i></p> <p>Peso Weight kg/ml 0.303</p> <p>Jx 00.00 cm⁴ Wx 00.00 cm³</p> <p>Jy 00.00 cm⁴ Wy 00.00 cm³</p>		Tavola Table 41	<p>XX70.603</p> <p>Soglia piana Flat Treshold</p> <p>Peso Weight kg/ml 0.276</p> <p>Jx 00.00 cm⁴ Wx 00.00 cm³</p> <p>Jy 00.00 cm⁴ Wy 00.00 cm³</p>		Tavola Table 32
<p>CX70.571</p> <p>Fermavetro Clips Tondo 14 mm. <i>Round glazing bead Clips 14 mm.</i></p> <p>Peso Weight kg/ml 0.215</p> <p>Jx 00.00 cm⁴ Wx 00.00 cm³</p> <p>Jy 00.00 cm⁴ Wy 00.00 cm³</p>		Tavola Table 42	<p>CX65.604</p> <p>Inversione di Battuta Rabbet Reversal</p> <p>Peso Weight kg/ml 1.140</p> <p>Jx 17.84 cm⁴ Wx 4.74 cm³</p> <p>Jy 4.38 cm⁴ Wy 1.38 cm³</p>		Tavola Table 31
<p>CX70.572</p> <p>Fermavetro Clips Tondo 18 mm. <i>Round glazing bead Clips 18 mm.</i></p> <p>Peso Weight kg/ml 0.275</p> <p>Jx 00.00 cm⁴ Wx 00.00 cm³</p> <p>Jy 00.00 cm⁴ Wy 00.00 cm³</p>		Tavola Table 42	<p>CX70.605</p> <p>Astina Bar</p> <p>Peso Weight kg/ml 0.146</p> <p>Jx 00.00 cm⁴ Wx 00.00 cm³</p> <p>Jy 00.00 cm⁴ Wy 00.00 cm³</p>		Tavola Table 32
<p>CX70.573</p> <p>Fermavetro Clips Tondo 22 mm. <i>Round glazing bead Clips 22 mm.</i></p> <p>Peso Weight kg/ml 0.298</p> <p>Jx 00.00 cm⁴ Wx 00.00 cm³</p> <p>Jy 00.00 cm⁴ Wy 00.00 cm³</p>		Tavola Table 42	<p>XX70.606</p> <p>Scivolo Esterno Soglia Bassa <i>Bottom threshold external slide</i></p> <p>Peso Weight kg/ml 0.322</p> <p>Jx 00.00 cm⁴ Wx 00.00 cm³</p> <p>Jy 00.00 cm⁴ Wy 00.00 cm³</p>		Tavola Table 33
<p>CX70.574</p> <p>Fermavetro Clips Tondo 26 mm. <i>Round glazing bead Clips 26 mm.</i></p> <p>Peso Weight kg/ml 0.329</p> <p>Jx 00.00 cm⁴ Wx 00.00 cm³</p> <p>Jy 00.00 cm⁴ Wy 00.00 cm³</p>		Tavola Table 42	<p>CX65.607</p> <p>Scivolo Interno Soglia Bassa <i>Bottom threshold internal slide</i></p> <p>Peso Weight kg/ml 0.224</p> <p>Jx 00.00 cm⁴ Wx 00.00 cm³</p> <p>Jy 00.00 cm⁴ Wy 00.00 cm³</p>		Tavola Table 33
<p>CX70.575</p> <p>Fermavetro Clips Tondo 30 mm. <i>Round glazing bead Clips 30 mm.</i></p> <p>Peso Weight kg/ml 0.354</p> <p>Jx 00.00 cm⁴ Wx 00.00 cm³</p> <p>Jy 00.00 cm⁴ Wy 00.00 cm³</p>		Tavola Table 42	<p>RX70.609</p> <p>Chiusura Rinforzo Montanti <i>Uprights reinforcement closure depth</i></p> <p>Peso Weight kg/ml 0.392</p> <p>Jx 0.10 cm⁴ Wx 00.11 cm³</p> <p>Jy 3.99 cm⁴ Wy 1.53 cm³</p>		Tavola Table 16

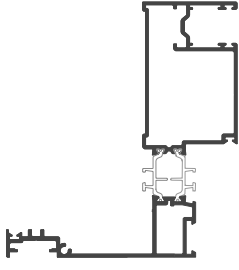
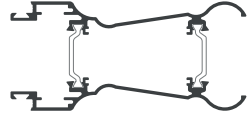
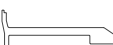

<p>RX70.610</p> <p>Rinforzo Montanti <i>Uprights reinforcement</i></p> <p>Peso Weight kg/ml 0.994</p> <p>Jx 12.49 cm⁴ Wx 3.56 cm³</p> <p>Jy 17.78 cm⁴ Wy 6.84 cm³</p>	 <p>Tavola Table 16</p>	<p>CX65.642</p> <p>Battuta riportata per zoccolo <i>Added rabbet for sill</i></p> <p>Peso Weight kg/ml 0.662</p> <p>Jx 11.42 cm⁴ Wx 3.18 cm³</p> <p>Jy 07.19 cm⁴ Wy 3.99 cm³</p>	 <p>Tavola Table 29</p>
<p>XX70.611</p> <p>Profilo per squadretta <i>Corner Joint Profile</i></p> <p>Peso Weight kg/ml 3.475</p> <p>Jx 00.00 cm⁴ Wx 00.00 cm³</p> <p>Jy 00.00 cm⁴ Wy 00.00 cm³</p>	 <p>Tavola Table 32</p>	<p>XX70.643</p> <p>Porta Spazzolino Anta <i>Sash Brush Holder</i></p> <p>Peso Weight kg/ml 0.265</p> <p>Jx 00.00 cm⁴ Wx 00.00 cm³</p> <p>Jy 00.00 cm⁴ Wy 00.00 cm³</p>	 <p>Tavola Table 16</p>
<p>XX70.612</p> <p>Profilo bancalino <i>Pallet profile</i></p> <p>Peso Weight kg/ml 0.248</p> <p>Jx 00.00 cm⁴ Wx 00.00 cm³</p> <p>Jy 00.00 cm⁴ Wy 00.00 cm³</p>	 <p>Tavola Table 33</p>	<p>XX70.648</p> <p>Profilo di battuta Capannoni <i>Shed profile</i></p> <p>Peso Weight kg/ml 0.801</p> <p>Jx 00.00 cm⁴ Wx 00.00 cm³</p> <p>Jy 00.00 cm⁴ Wy 00.00 cm³</p>	 <p>Tavola Table 31</p>
<p>XX70.613</p> <p>Angolo universale <i>Universal Corner profile</i></p> <p>Peso Weight kg/ml 1.861</p> <p>Jx 00.00 cm⁴ Wx 00.00 cm³</p> <p>Jy 00.00 cm⁴ Wy 00.00 cm³</p>	 <p>Tavola Table 31</p>	<p>XX65.701</p> <p>Spalla laterale chiusa <i>Closed Side Reveal</i></p> <p>Peso Weight kg/ml 3.134</p> <p>Jx 243.00 cm⁴ Wx 33.51 cm³</p> <p>Jy 129.18 cm⁴ Wy 19.16 cm³</p>	 <p>Tavola Table 34</p>
<p>CX65.627</p> <p>Battuta riportata per zoccolo <i>Added rabbet for sill</i></p> <p>Peso Weight kg/ml 0.616</p> <p>Jx 11.39 cm⁴ Wx 3.11 cm³</p> <p>Jy 07.16 cm⁴ Wy 3.94 cm³</p>	 <p>Tavola Table 29</p>		
<p>XX60.635</p> <p>Battuta riportata per telaio <i>Added rabbet for frame</i></p> <p>Peso Weight kg/ml 0.306</p> <p>Jx 00.00 cm⁴ Wx 00.00 cm³</p> <p>Jy 00.00 cm⁴ Wy 00.00 cm³</p>	 <p>Tavola Table 33</p>	<p>CX65.702</p> <p>Spalla laterale aperta <i>Open Side Reveal</i></p> <p>Peso Weight kg/ml 2.566</p> <p>Jx 202.39 cm⁴ Wx 27.02 cm³</p> <p>Jy 87.13 cm⁴ Wy 10.95 cm³</p>	 <p>Tavola Table 34</p>
<p>XX70.636</p> <p>Doga <i>Stave profile</i></p> <p>Peso Weight kg/ml 1.674</p> <p>Jx 00.00 cm⁴ Wx 00.00 cm³</p> <p>Jy 00.00 cm⁴ Wy 00.00 cm³</p>	 <p>Tavola Table 35</p>		
<p>CX65.640</p> <p>Profilo Sostegno Inversione <i>Support Profile Reversal</i></p> <p>Peso Weight kg/ml 0.861</p> <p>Jx 00.00 cm⁴ Wx 00.00 cm³</p> <p>Jy 00.00 cm⁴ Wy 00.00 cm³</p>	 <p>Tavola Table 32</p>	<p>XX70.703</p> <p>Traverso Superiore Monoblocco <i>Upper Monobloc Crosspiece</i></p> <p>Peso Weight kg/ml 0.832</p> <p>Jx 00.00 cm⁴ Wx 00.00 cm³</p> <p>Jy 00.00 cm⁴ Wy 00.00 cm³</p>	 <p>Tavola Table 35</p>



XX70.704			Tavola Table 35
Coprivite Screw Cover			
Peso Weight	kg/ml 0.135		
Jx 00.00 cm ⁴	Wx 00.00 cm ³		
Jy 00.00 cm ⁴	Wy 00.00 cm ³		

XX70.2040			Tavola Table 32
Gocciolatoio Mini Mini Drip Tray			
Peso Weight	kg/ml 0.095		
Jx 00.00 cm ⁴	Wx 00.00 cm ³		
Jy 00.00 cm ⁴	Wy 00.00 cm ³		

XX70.705			Tavola Table 35
Profilo battuta cassonetto Shutter box rabbet profile			
Peso Weight	kg/ml 0.155		
Jx 00.00 cm ⁴	Wx 00.00 cm ³		
Jy 00.00 cm ⁴	Wy 00.00 cm ³		

			Tavola Table 38
Centrale per Cassonetto Central Shutter Box			
Peso Weight	kg/ml 1.153		
Jx 00.00 cm ⁴	Wx 00.00 cm ³		
Jy 00.00 cm ⁴	Wy 00.00 cm ³		

CX65.706			Tavola Table 35
Mezza spalla monoblocco Monobloc Half Reveal			
Peso Weight	kg/ml 2.054		
Jx 138.93 cm ⁴	Wx 18.85 cm ³		
Jy 18.60 cm ⁴	Wy 6.48 cm ³		

XX70.801			Tavola Table 36
Imbotte da 120 mm. Jamb 120 mm.			
Peso Weight	kg/ml 1.321		
Jx 76.93 cm ⁴	Wx 9.91 cm ³		
Jy 20.54 cm ⁴	Wy 4.10 cm ³		

CX45.3363			Tavola Table 38
Super./Infer. Cassonetto Upper/Lower Shutter Box			
Peso Weight	kg/ml 1.385		
Jx 00.00 cm ⁴	Wx 00.00 cm ³		
Jy 00.00 cm ⁴	Wy 00.00 cm ³		

XX70.802			Tavola Table 36
Prolunga Imbotte 90 mm. 90 mm. Jamb Extension			
Peso Weight	kg/ml 0.882		
Jx 00.00 cm ⁴	Wx 00.00 cm ³		
Jy 00.00 cm ⁴	Wy 00.00 cm ³		

XX70.803			Tavola Table 36
Prolunga Imbotte 50 mm. 50 mm. Jamb Extension			
Peso Weight	kg/ml 0.574		
Jx 00.00 cm ⁴	Wx 00.00 cm ³		
Jy 00.00 cm ⁴	Wy 00.00 cm ³		

XX70.808			Tavola Table 36
Jolly per Imbotte Jolly for Jamb			
Peso Weight	kg/ml 0.750		
Jx 00.00 cm ⁴	Wx 00.00 cm ³		
Jy 00.00 cm ⁴	Wy 00.00 cm ³		

XX70.809			Tavola Table 36
Imbotte 140 mm. Jamb 140 mm.			
Peso Weight	kg/ml 1.500		
Jx 123.04 cm ⁴	Wx 13.89 cm ³		
Jy 22.31 cm ⁴	Wy 4.30 cm ³		

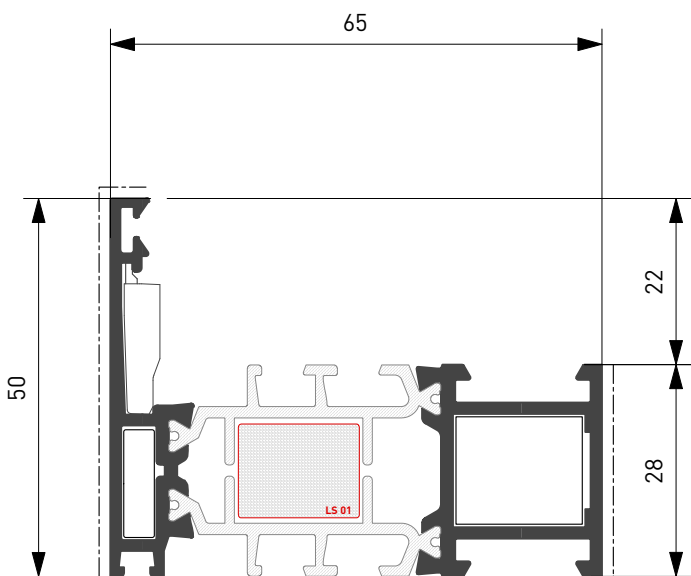

CX65.101

Kg/ml 1.144
--- mm. 78,0

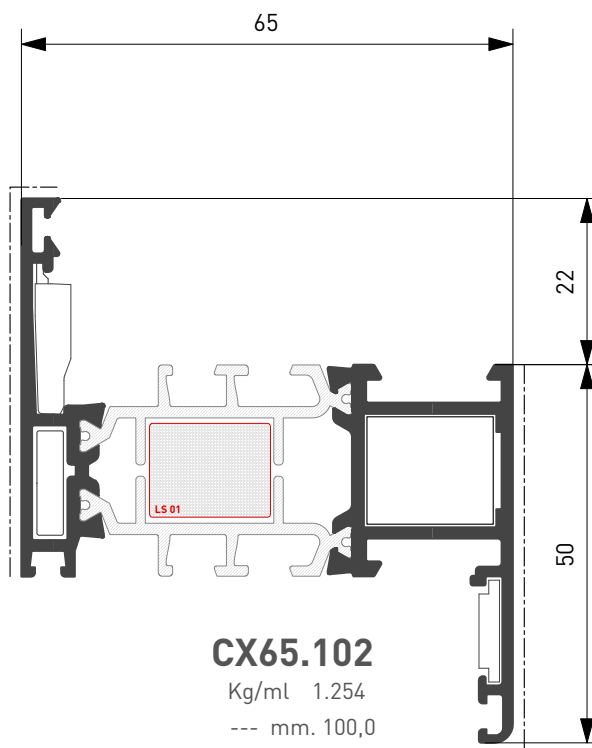

CX65.102

Kg/ml 1.254
--- mm. 100,0

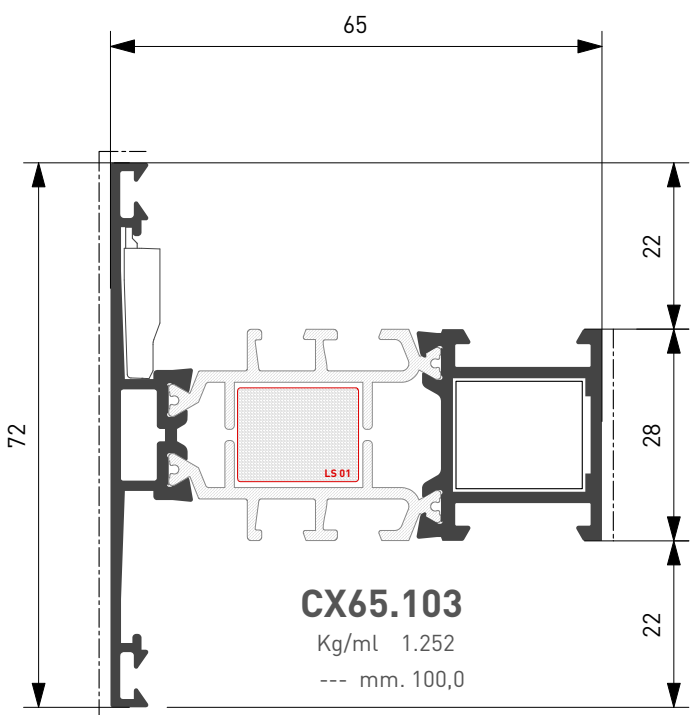

CX65.103

Kg/ml 1.252
--- mm. 100,0

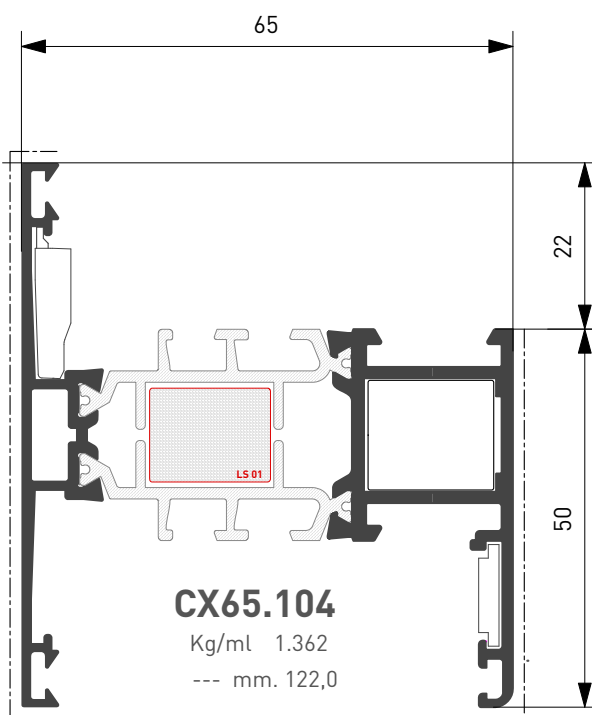

CX65.104

Kg/ml 1.362
--- mm. 122,0

Profilato Profile	Squadretta esterna External Corner Joint		Squadretta interna Internal Corner Joint					Sq. Allineamento Alining Corner J.	
	Cianfrinare Riveting	Spinare Crimping	Bottone Slot	Cianfrinare Riveting	Spinare Crimping	Avvitare Screw	Esterna External	Interna Internal	
CX65.101	ARX.03.SQ	ARX.03.SQ + ARX.08.SQ	ACX.16.SQ	*AWX.19.SQ	+ ARX07.SQ + VIL M5x14 D8		ARX.15.SQ		
CX65.102	ARX.03.SQ	ARX.03.SQ + ARX.08.SQ	ACX.16.SQ	*AWX.19.SQ	+ ARX07.SQ + VIL M5x14 D8		ARX.15.SQ	ARX.10.SQ	
CX65.103			ACX.16.SQ	*AWX.19.SQ	+ ARX07.SQ + VIL M5x14 D8		ARX.15.SQ		
CX65.104			ACX.16.SQ	*AWX.19.SQ	+ ARX07.SQ + VIL M5x14 D8		ARX.15.SQ	ARX.10.SQ	

***Per spinatura aggiungere ARX07.SQ | Per avvitatura aggiungere VIL M5x14_D8 [Gruppo C]**

***For crimping add ARX07.SQ | For Screw add VIL M5x14_D8 [Group C]**

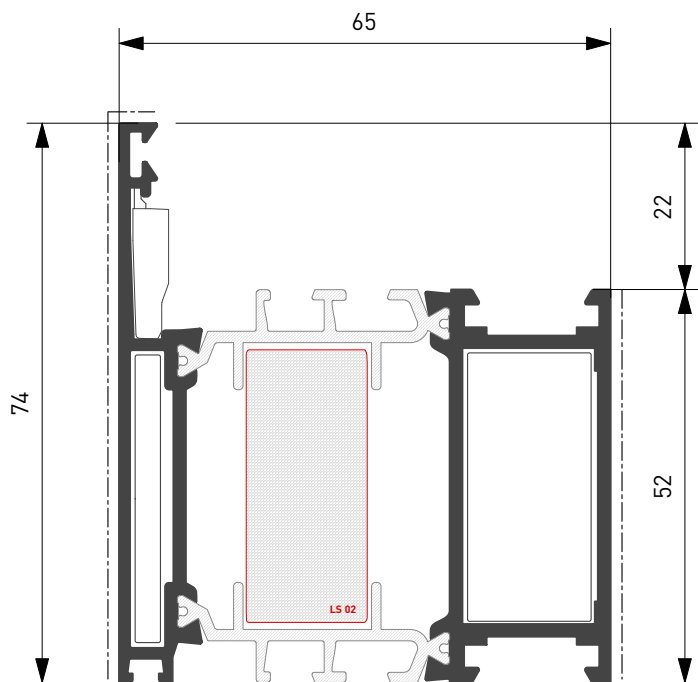

CX65.105

Kg/ml 1.620
--- mm. 126,0

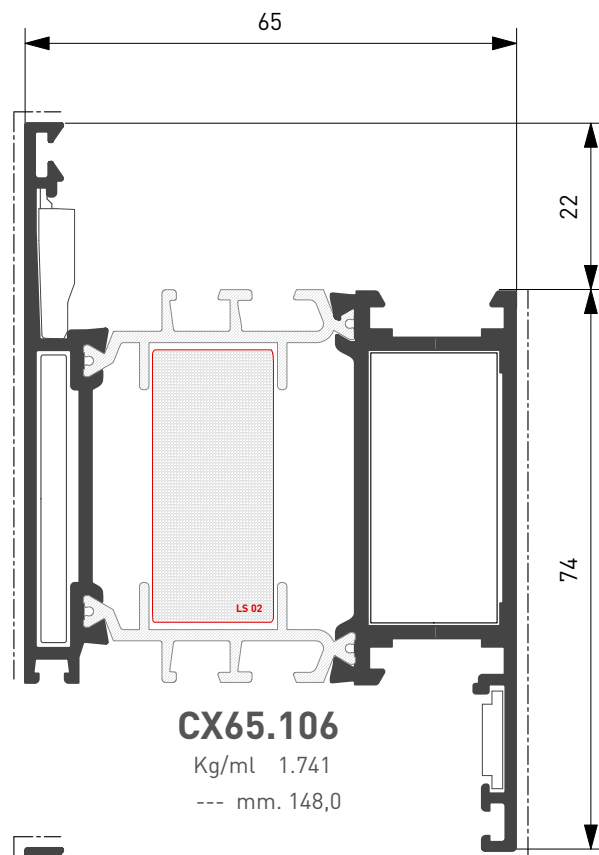

CX65.106

Kg/ml 1.741
--- mm. 148,0

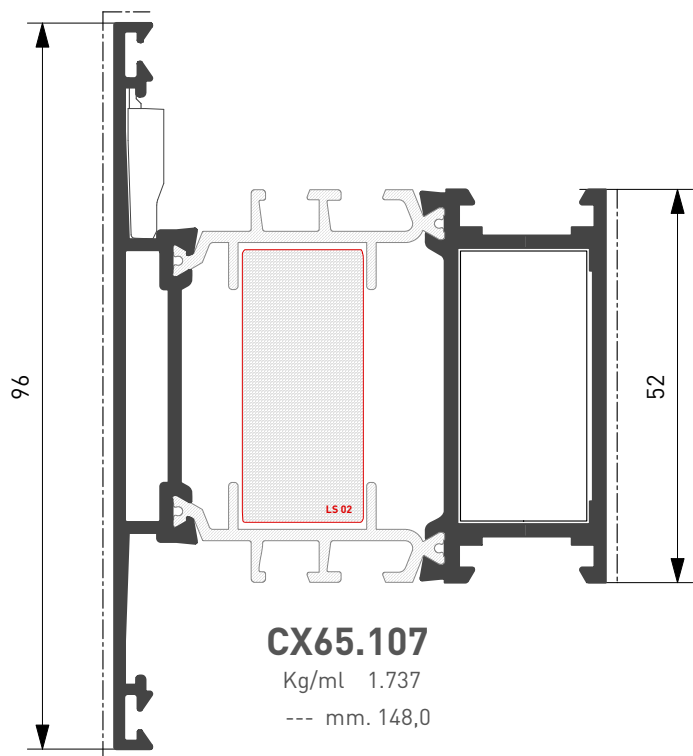

CX65.107

Kg/ml 1.737
--- mm. 148,0

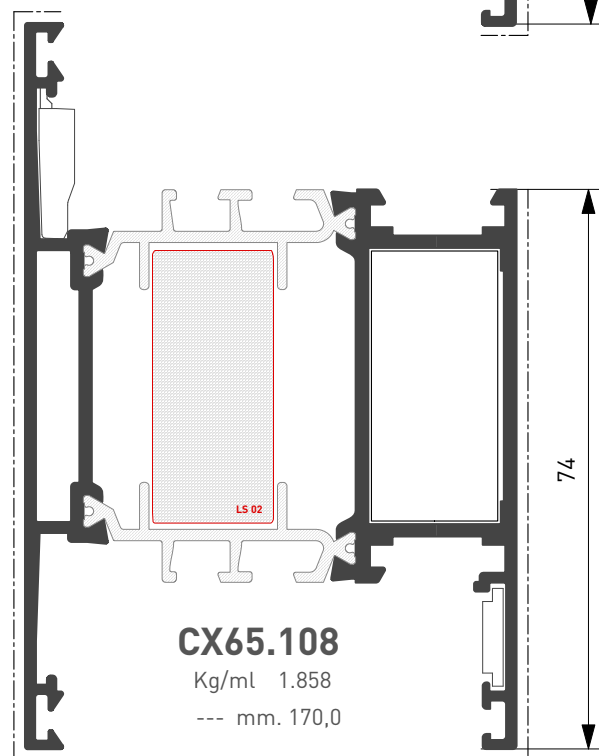

CX65.108

Kg/ml 1.858
--- mm. 170,0

Profilato Profile	Squadretta esterna External Corner Joint				Squadretta interna Internal Corner Joint						Sq. Allineamento Alining Corner J.			
	Cianfrinare Riveting		Spinare Crimping		Bottone Slot	Cianfrinare Riveting	Spinare Crimping	Avvitare Screw		Esterna External	Interna Internal			
CX65.105	ARX.06.SQ	ARX.06.SQ + ARX.08.SQ		*AWX.17.SQ + ARX07.SQ + VIL M5x14 D8						ARX.15.SQ				
CX65.106	ARX.06.SQ	ARX.06.SQ + ARX.08.SQ		*AWX.17.SQ + ARX07.SQ + VIL M5x14 D8						ARX.15.SQ		ARX.10.SQ		
CX65.107				*AWX.17.SQ + ARX07.SQ + VIL M5x14 D8						ARX.15.SQ				
CX65.108				*AWX.17.SQ + ARX07.SQ + VIL M5x14 D8						ARX.15.SQ		ARX.10.SQ		

***Per spinatura aggiungere ARX07.SQ | Per avvitatura aggiungere VIL M5x14_D8 [Gruppo C]**
***For crimping add ARX07.SQ | For Screw add VIL M5x14_D8 [Group C]**

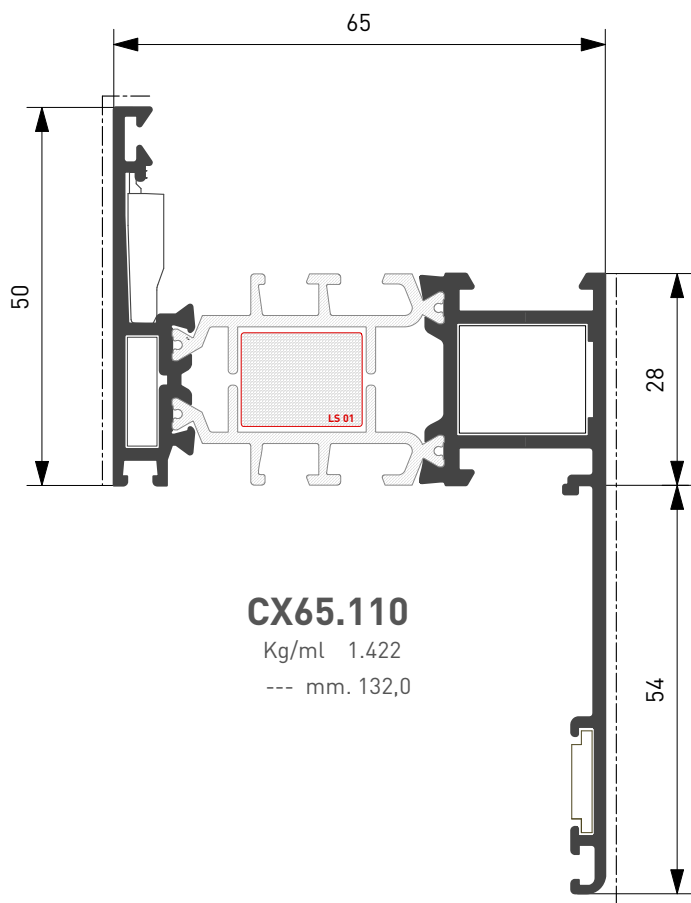

CX65.110
Kg/ml 1.422
--- mm. 132,0

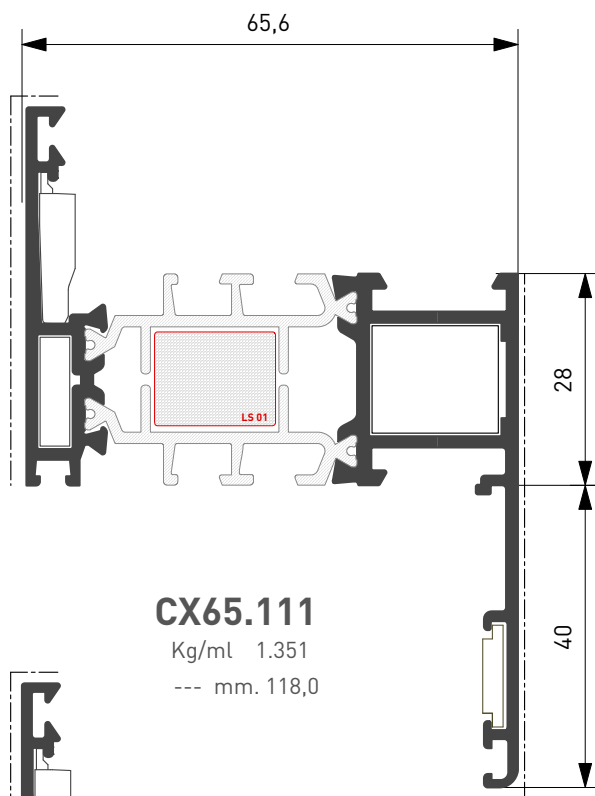

CX65.111
Kg/ml 1.351
--- mm. 118,0

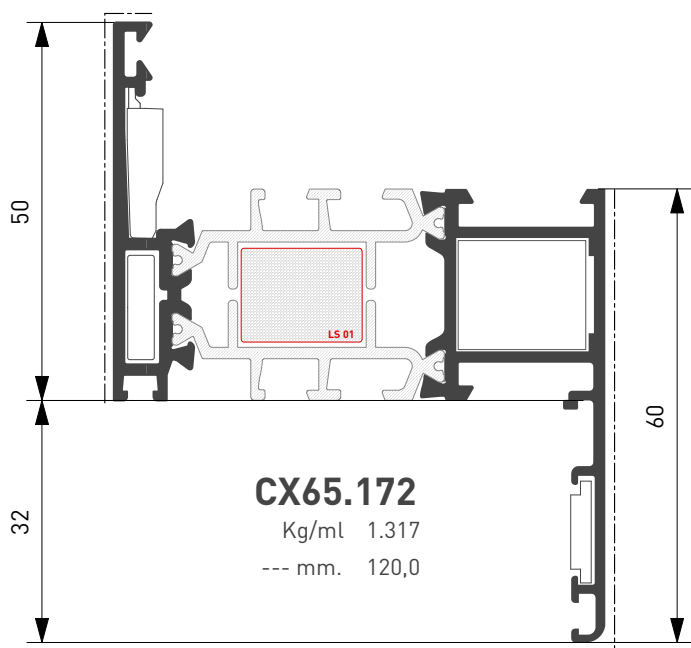

CX65.172
Kg/ml 1.317
--- mm. 120,0

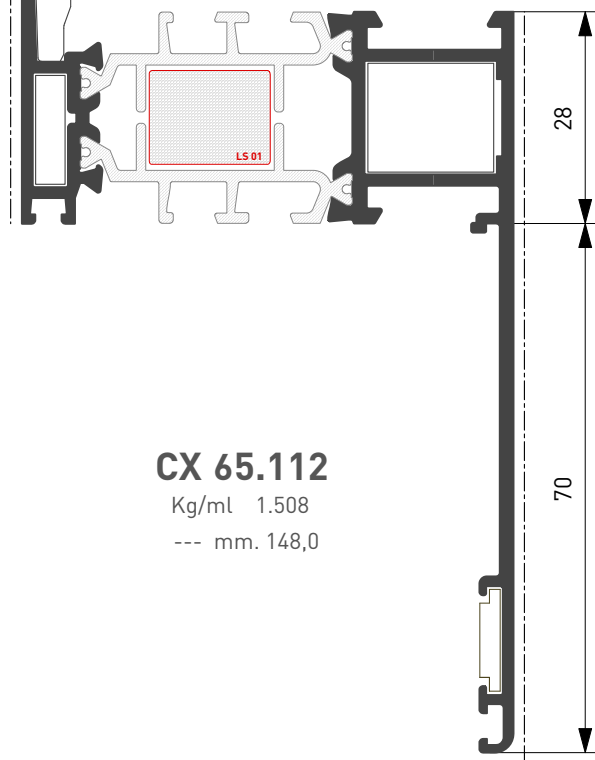

CX 65.112
Kg/ml 1.508
--- mm. 148,0

Profilato Profile	Squadretta esterna External Corner Joint		Squadretta interna Internal Corner Joint					Sq. Allineamento Alining Corner J.	
	Cianfrinare Riveting	Spinare Crimping	Bottone Slot	Cianfrinare Riveting	Spinare Crimping	Avvitare Screw	Esterna External	Interna Internal	
CX65.110	ARX.03.SQ	ARX.03.SQ + ARX.08.SQ	ACX.16.SQ	*AWX.19.SQ	+ ARX07.SQ + VIL M5x14 D8		ARX.15.SQ	ARX.10.SQ	
CX65.111	ARX.03.SQ	ARX.03.SQ + ARX.08.SQ	ACX.16.SQ	*AWX.19.SQ	+ ARX07.SQ + VIL M5x14 D8		ARX.15.SQ	ARX.10.SQ	
CX65.112	ARX.03.SQ	ARX.03.SQ + ARX.08.SQ	ACX.16.SQ	*AWX.19.SQ	+ ARX07.SQ + VIL M5x14 D8		ARX.15.SQ	ARX.10.SQ	
CX65.172	ARX.03.SQ	ARX.03.SQ + ARX.08.SQ	ACX.16.SQ	*AWX.19.SQ	+ ARX07.SQ + VIL M5x14 D8		ARX.15.SQ	ARX.10.SQ	

*Per spinatura aggiungere ARX07.SQ | Per avvitatura aggiungere VIL M5x14_D8 [Gruppo C]
*For crimping add ARX07.SQ | For Screw add VIL M5x14_D8 [Group C]

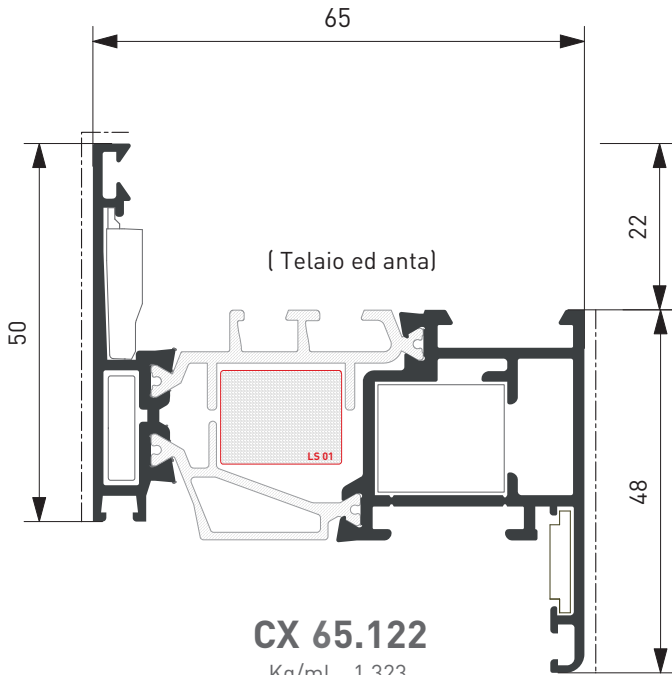

CX 65.122
Kg/ml 1.323
--- mm. 98

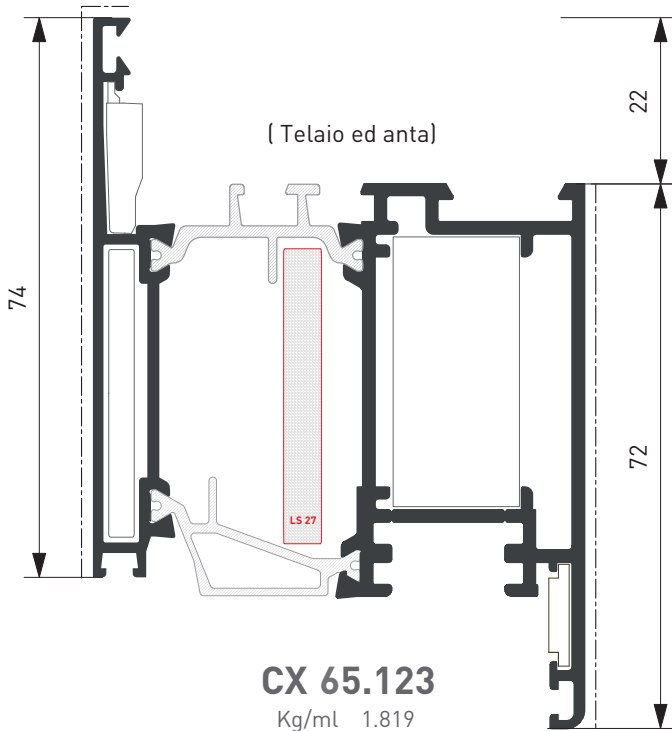

CX 65.123
Kg/ml 1.819
--- mm. 146

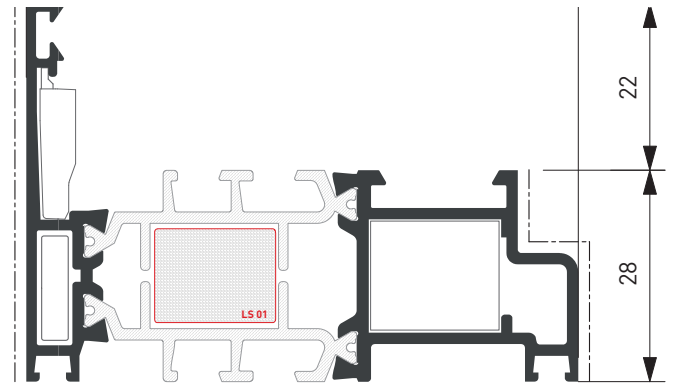

CX 65.119
Kg/ml 1.211
--- mm. 86,0

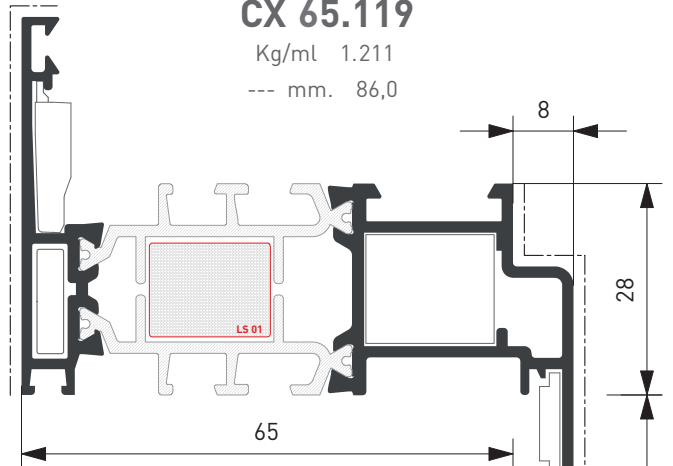

CX 65.120
Kg/ml 1.385
--- mm. 111,0

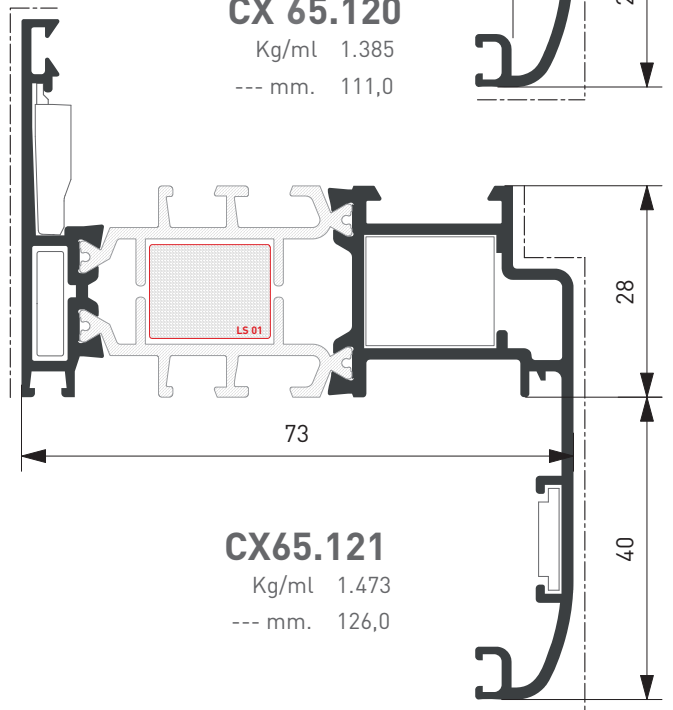

CX65.121
Kg/ml 1.473
--- mm. 126,0

Profilato Profile	Squadretta esterna External Corner Joint		Squadretta interna Internal Corner Joint				Sq. Allineamento Alining Corner J.	
	Cianfrinare Riveting	Spinare Crimping	Bottone Slot	Cianfrinare Riveting	Spinare Crimping	Avvitare Screw	Esterna External	Interna Internal
CX65.119	ARX.03.SQ	ARX.03.SQ + ARX.08.SQ	ACX.16.SQ	*AWX.19.SQ	+ ARX07.SQ + VIL M5x14 D8		ARX.15.SQ	
CX65.120	ARX.03.SQ	ARX.03.SQ + ARX.08.SQ	ACX.16.SQ	*AWX.19.SQ	+ ARX07.SQ + VIL M5x14 D8		ARX.15.SQ	ARX.10.SQ
CX65.121	ARX.03.SQ	ARX.03.SQ + ARX.08.SQ	ACX.16.SQ	*AWX.19.SQ	+ ARX07.SQ + VIL M5x14 D8		ARX.15.SQ	ARX.10.SQ
CX65.122	ARX.03.SQ	ARX.03.SQ + ARX.08.SQ	ACX.16.SQ	*AWX.19.SQ	+ ARX07.SQ + VIL M5x14 D8		ARX.15.SQ	ARX.10.SQ
CX65.123	ARX.06.SQ	ARX.06.SQ + ARX.08.SQ		*AWX.17.SQ	+ ARX07.SQ + VIL M5x14 D8		ARX.15.SQ	ARX.10.SQ

*Per spinatura aggiungere ARX07.SQ | Per avvitatura aggiungere VIL M5x14_D8 [Gruppo C]
*For crimping add ARX07.SQ | For Screw add VIL M5x14_D8 [Group C]

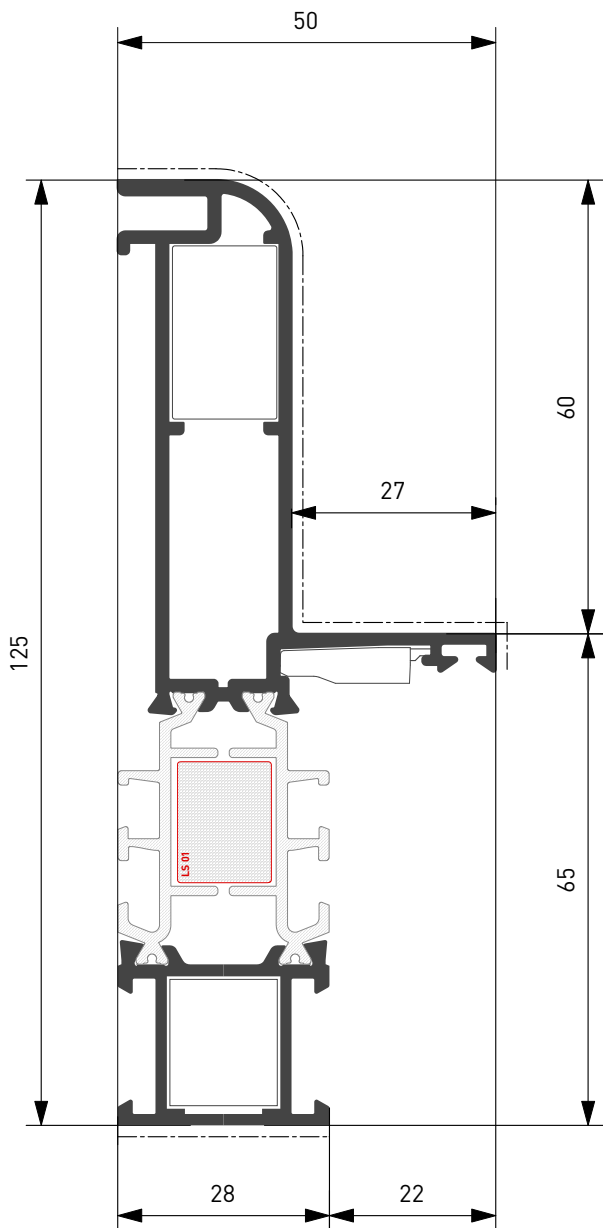

CX65.116

Kg/ml 1.738
--- mm. 143,0

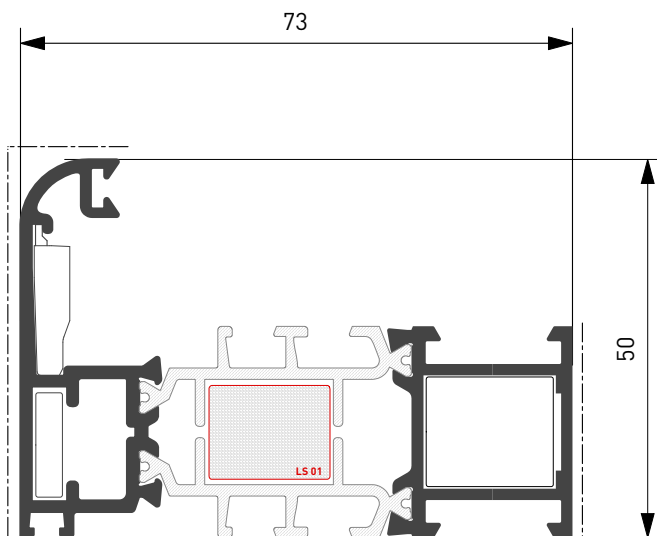

CX65.152

Kg/ml 1.291
--- mm. 86,0

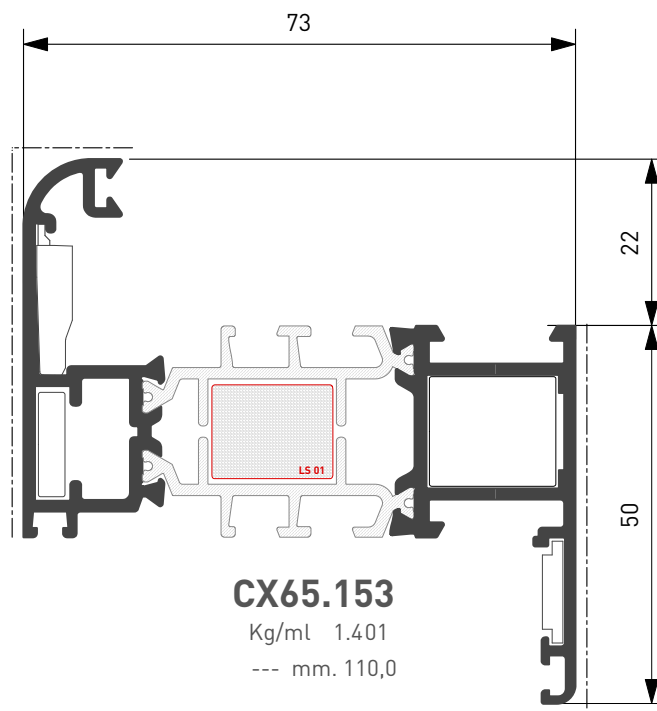

CX65.153

Kg/ml 1.401
--- mm. 110,0

Profilato Profile	Squadretta esterna External Corner Joint				Squadretta interna Internal Corner Joint						Sq. Allineamento Alining Corner J.			
	Bottone Slot	Cianfrinare Riveting	Spinare Crimping		Bottone Slot	Cianfrinare Riveting	Spinare Crimping	Avvitare Screw			Esterna External	Interna Internal		
CX65.116	ARX.13.SQ				ACX.16.SQ	AWX.19.SQ	+ ARX07.SQ + VIL M5x14 D8			ARX.15.SQ				
CX65.152		ARX.03.SQ	+ ARX.08.SQ		ACX.16.SQ	AWX.19.SQ	+ ARX07.SQ + VIL M5x14 D8			ARX.15.SQ				
CX65.153		ARX.03.SQ	+ ARX.08.SQ		ACX.16.SQ	AWX.19.SQ	+ ARX07.SQ + VIL M5x14 D8			ARX.15.SQ		ARX.10.SQ		

***Per spinatura aggiungere ARX07.SQ | Per avvitatura aggiungere VIL M5x14_D8 [Gruppo C]**
***For crimping add ARX07.SQ | For Screw add VIL M5x14_D8 [Group C]**

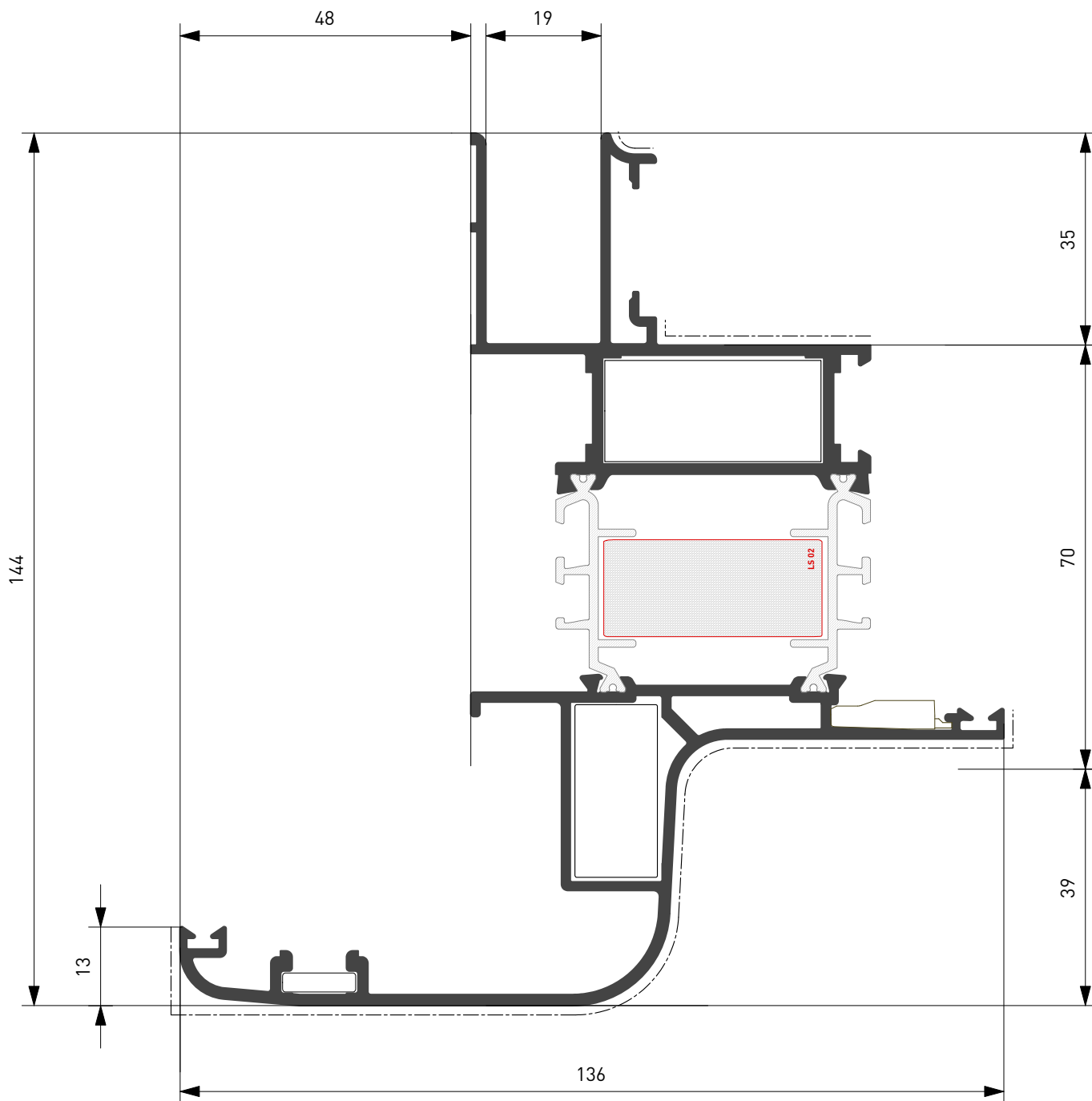

CX65.109

Kg/ml 2.958

--- mm. 242,0

Profilato Profile	Squadretta esterna External Corner Joint				Squadretta interna Internal Corner Joint				Sq. Allineamento Alining Corner J.	
	Cianfrinare Riveting	Spinare Crimping	Avvitare Screw		Bottone Slot	Cianfrinare Riveting	Spinare Crimping	Avvitare Screw	Esterna External	Interna Internal
CX65.109	ACX.02.SQ	+ ARX.07.SQ	+VIL M5x14 D8		ACX.01.SQ	AWX.17.SQ	+ ARX07.SQ +	VIL M5x14 D8	ARX.11 e 15.SQ	

*Per spinatura aggiungere ARX07.SQ | Per avvitatura aggiungere VIL M5x14_D8 [Gruppo C]

*For crimping add ARX07.SQ | For Screw add VIL M5x14_D8 [Group C]

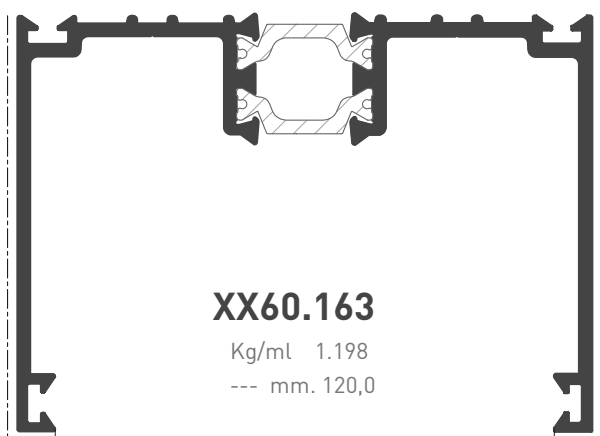

XX60.163

Kg/ml 1.198
--- mm. 120,0

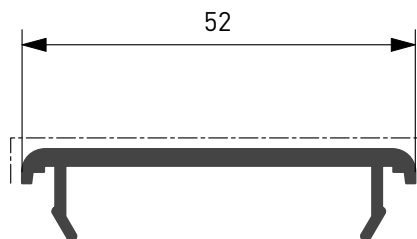

RX70.609

Kg/ml 0,392
--- mm. 55,0

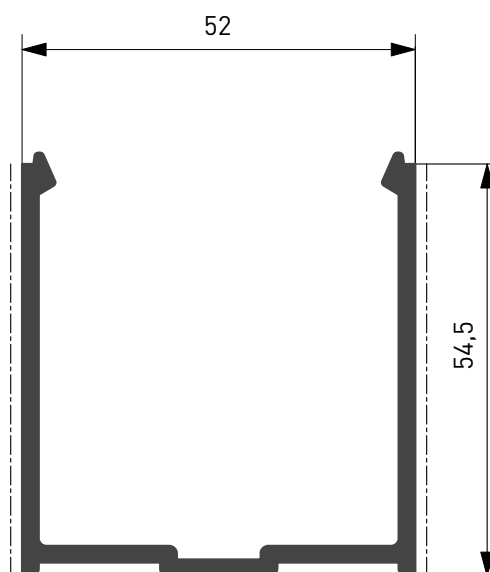

RX70.610

Kg/ml 0,994
--- mm. 109,0

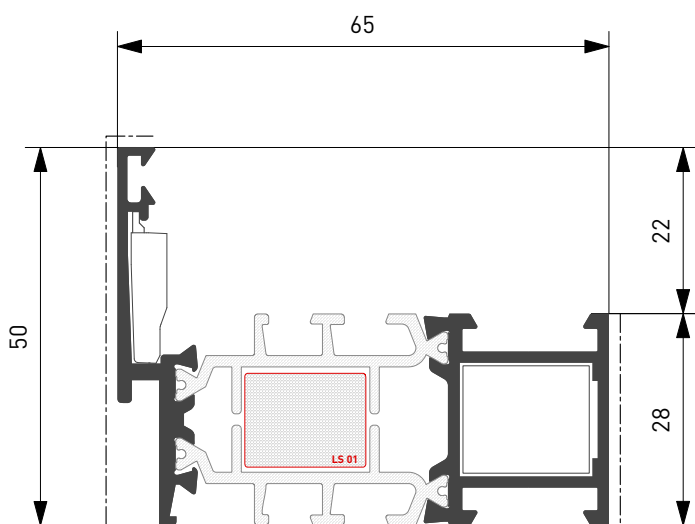

CX65.124

Kg/ml 1.116
--- mm. 78,0

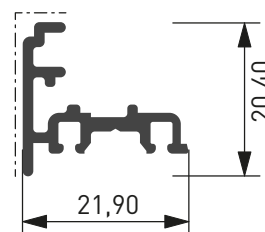

XX70.643

Kg/ml 0,265
--- mm. 28,0

Profilato Profile	Squadretta esterna External Corner Joint				Squadretta interna Internal Corner Joint							Sq. Allineamento Alining Corner J.			
	Cianfrinare Riveting	Spinare Crimping	Avvitare Screw	Slot	Bottone	Slot	Cianfrinare Riveting	Spinare Crimping	Avvitare Screw	Esterna External	Interna Internal	Esterna External	Interna Internal		
CX65.124					ACX.16.SQ		*AWX.19.SQ	+ ARX07.SQ	+ VIL M5x14 D8			ARX.15.SQ			

***Per spinatura aggiungere ARX07.SQ | Per avvitatura aggiungere VIL M5x14_D8 [Gruppo C]**
***For crimping add ARX07.SQ | For Screw add VIL M5x14_D8 [Group C]**

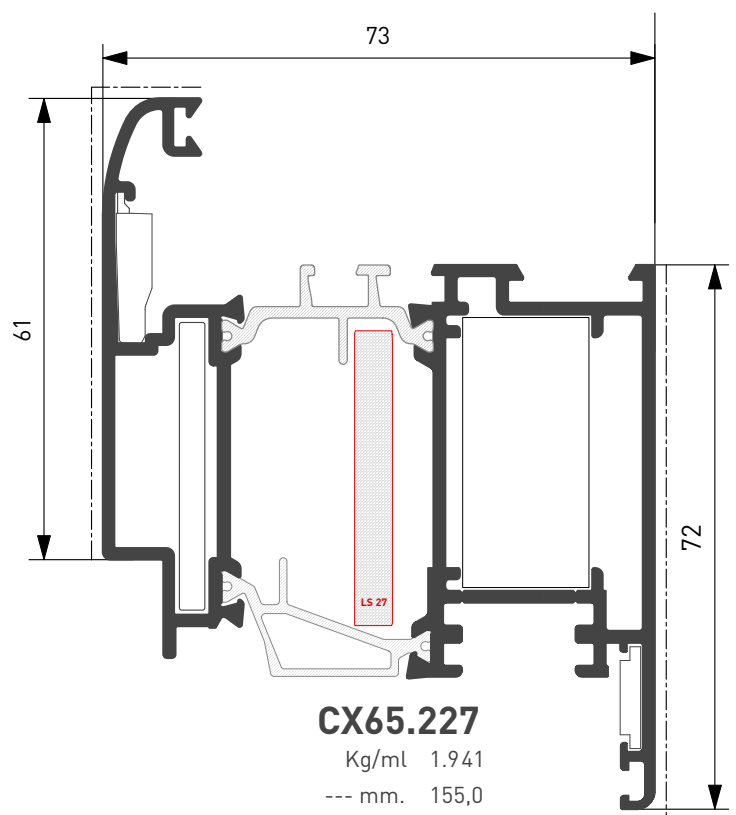
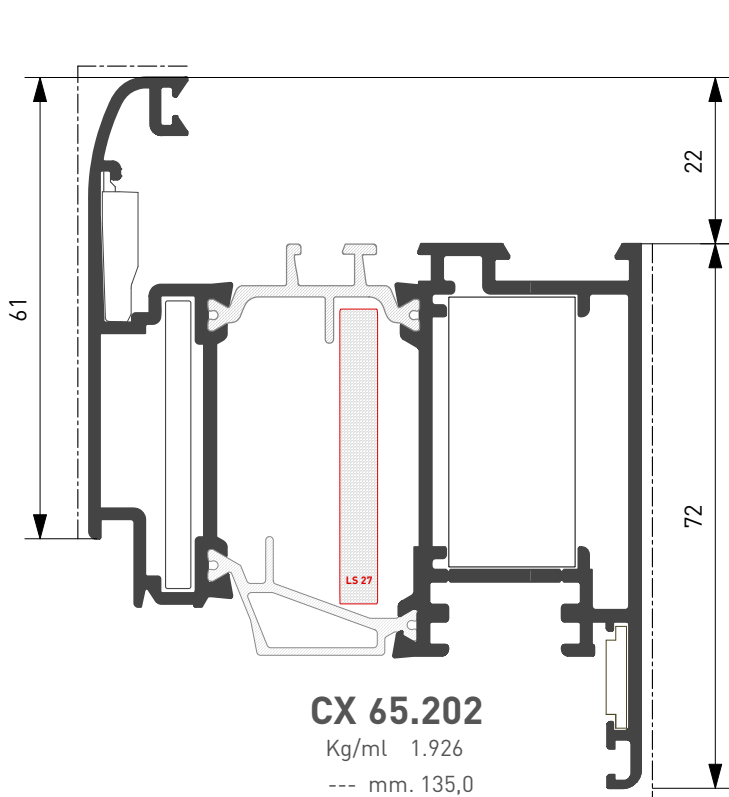
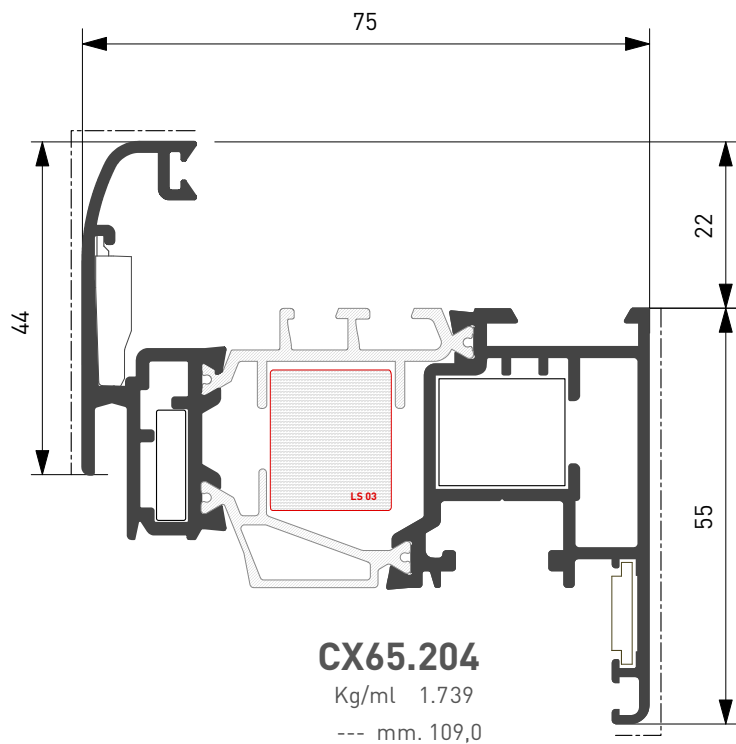
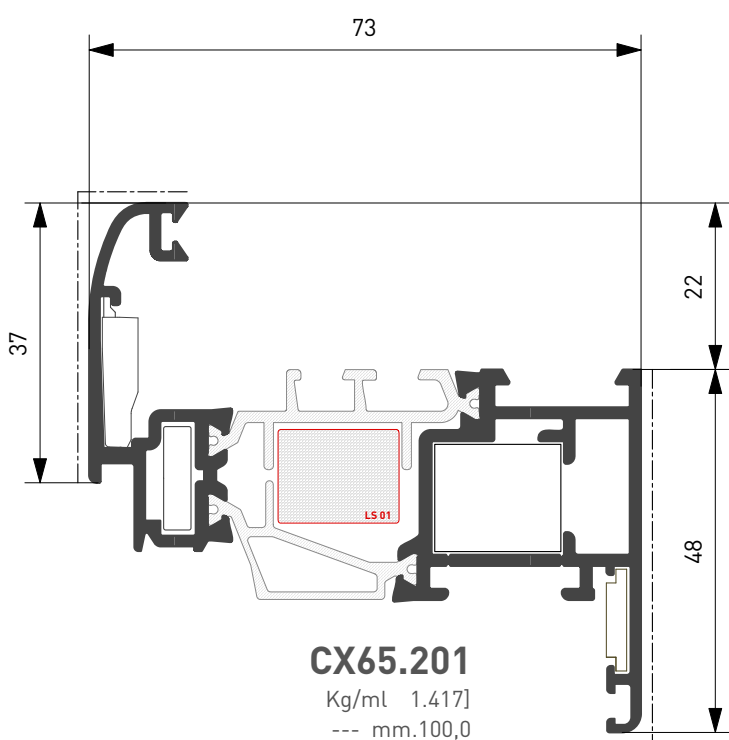

Profilato Profile	Squadretta esterna External Corner Joint		Squadretta interna Internal Corner Joint						Sq. Allineamento Alining Corner J.	
	Cianfrinare Riveting	Spinare Crimping	Bottone Slot	Cianfrinare Riveting	Spinare Crimping	Avvitare Screw	Esterna External	Interna Internal		
CX65.201	ARX.03.SQ	ARX.03.SQ + ARX.08.SQ	ACX.16.SQ	*AWX.19.SQ	+ ARX07.SQ + VIL M5x14 D8		ARX.15.SQ	ARX.10.SQ		
CX65.202	ARX.06.SQ	ARX.06.SQ + ARX.08.SQ		*AWX.17.SQ	+ ARX07.SQ + VIL M5x14 D8		ARX.15.SQ	ARX.10.SQ		
CX65.204	ARX.03.SQ	ARX.03.SQ + ARX.08.SQ	ACX.16.SQ	*AWX.19.SQ	+ ARX07.SQ + VIL M5x14 D8		ARX.15.SQ	ARX.10.SQ		
CX65.227	ARX.06.SQ	ARX.06.SQ + ARX.08.SQ		*AWX.17.SQ	+ ARX07.SQ + VIL M5x14 D8		ARX.15.SQ	ARX.10.SQ		

*Per spinatura aggiungere ARX07.SQ | Per avvitatura aggiungere VIL M5x14_D8 [Gruppo C]

*For crimping add ARX07.SQ | For Screw add VIL M5x14_D8 [Group C]

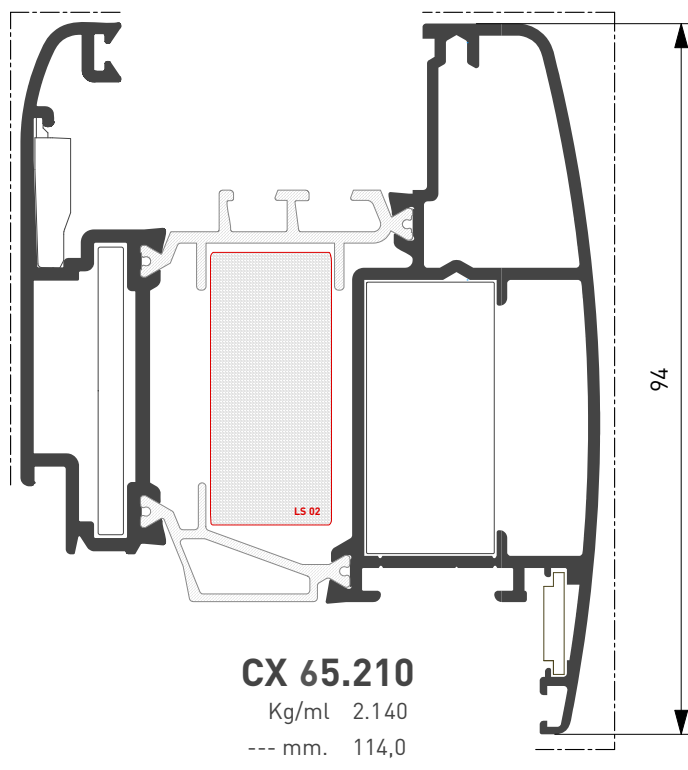
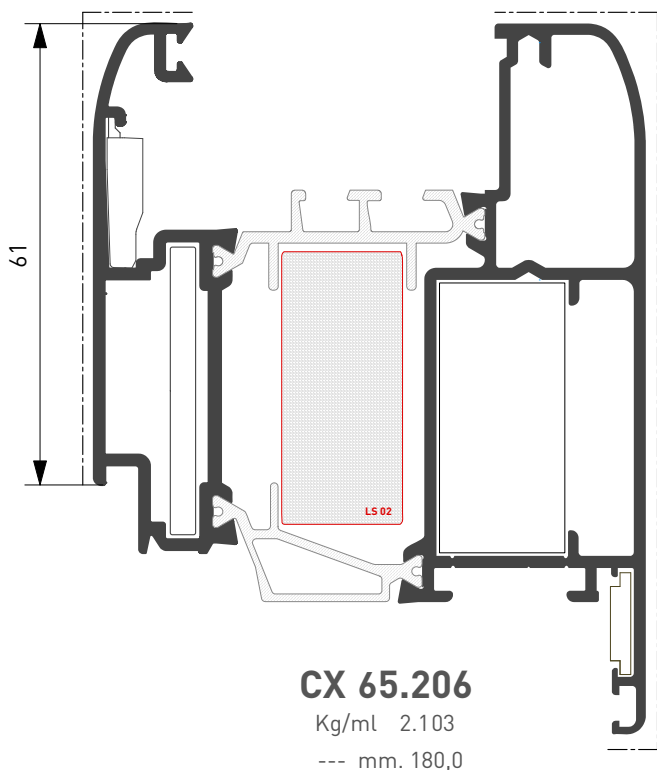
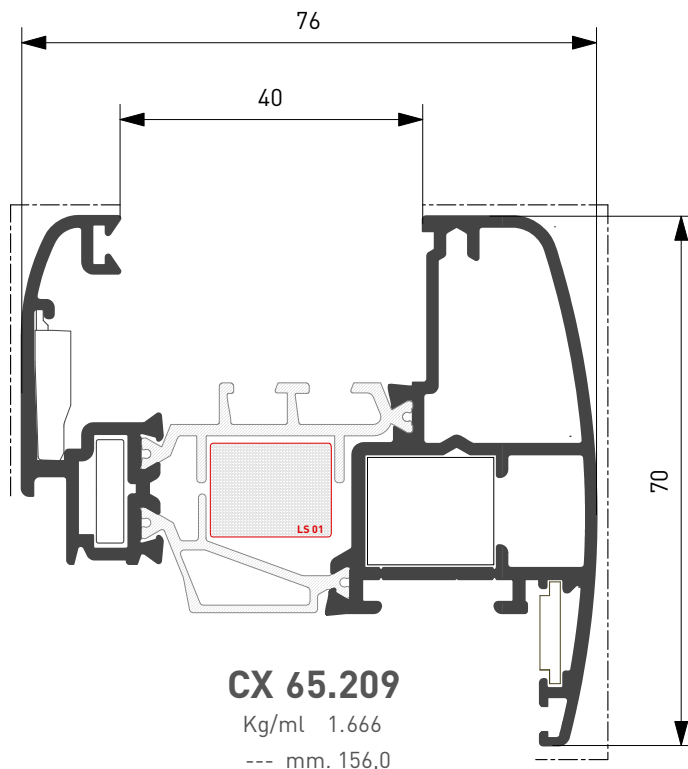
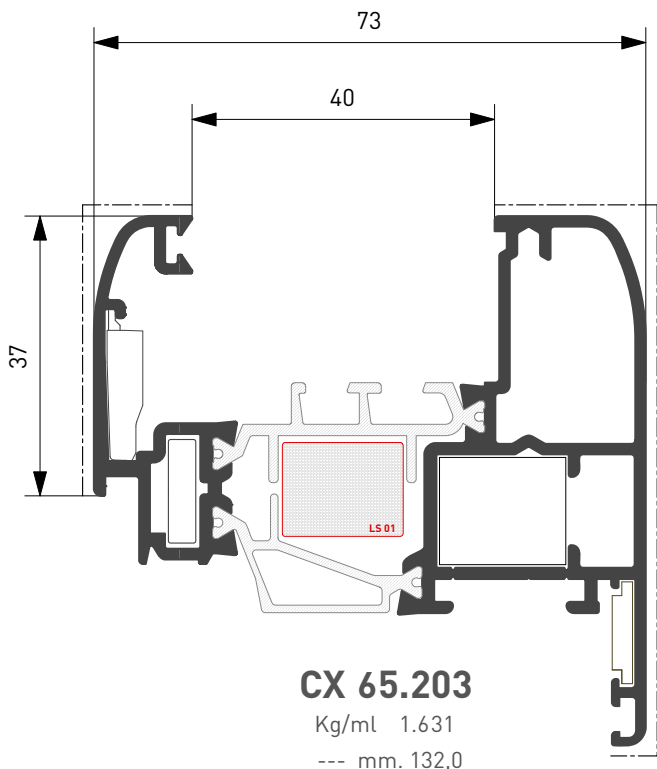

Profilato Profile	Squadretta esterna External Corner Joint		Squadretta interna Internal Corner Joint					Sq. Allineamento Alining Corner J.	
	Cianfrinare Riveting	Spinare Crimping	Bottone Slot	Cianfrinare Riveting	Spinare Crimping	Avvitare Screw	Esterna External	Interna Internal	
CX65.203		ARX.03.SQ + ARX.08.SQ	ACX.16.SQ	*AWX.19.SQ	+ ARX07.SQ + VIL M5x14 D8		ARX.15.SQ	ARX.10.SQ	
CX65.206		ARX.06.SQ + ARX.08.SQ		*AWX.17.SQ	+ ARX07.SQ + VIL M5x14 D8		ARX.15.SQ	ARX.10.SQ	
CX65.209		ARX.03.SQ + ARX.08.SQ	ACX.16.SQ	*AWX.19.SQ	+ ARX07.SQ + VIL M5x14 D8		ARX.15.SQ	ARX.10.SQ	
CX65.210		ARX.06.SQ + ARX.08.SQ		*AWX.17.SQ	+ ARX07.SQ + VIL M5x14 D8		ARX.15.SQ	ARX.10.SQ	

***Per spinatura aggiungere ARX07.SQ | Per avvitatura aggiungere VIL M5x14_D8 [Gruppo C]**
***For crimping add ARX07.SQ | For Screw add VIL M5x14_D8 [Group C]**

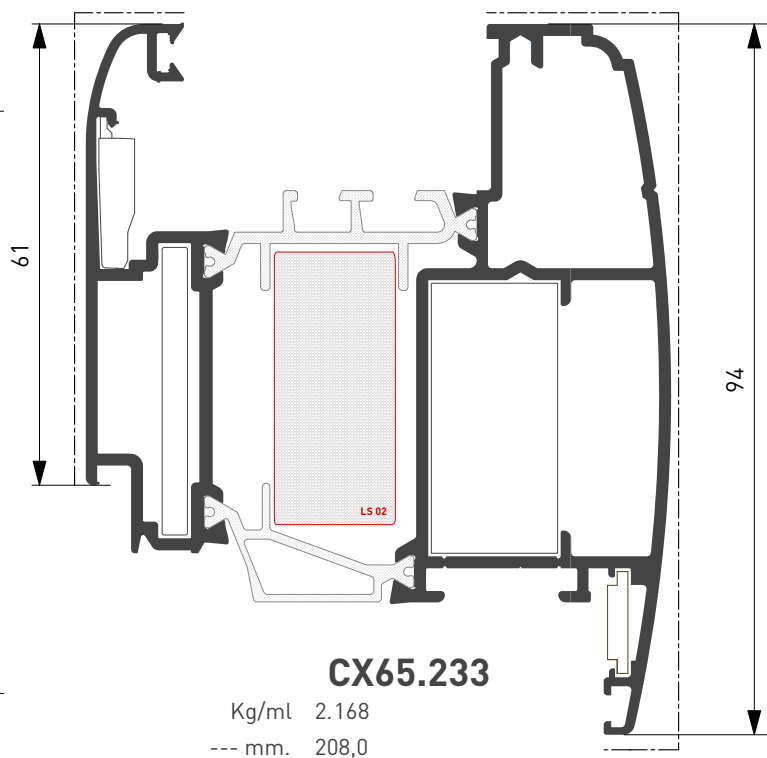
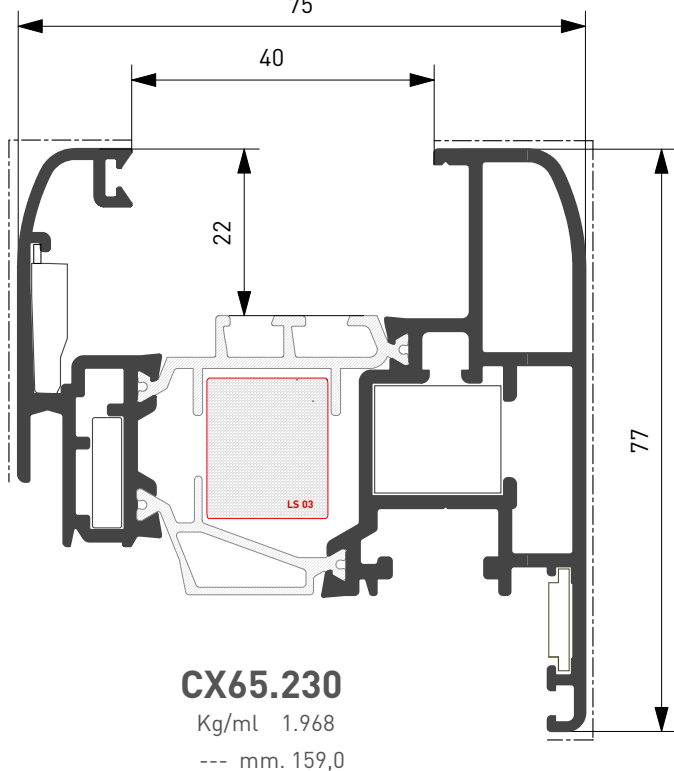
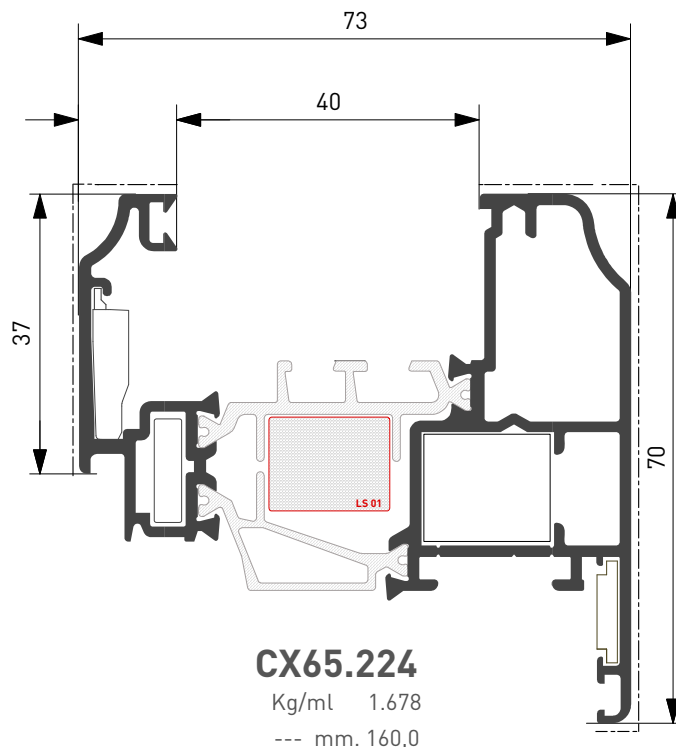
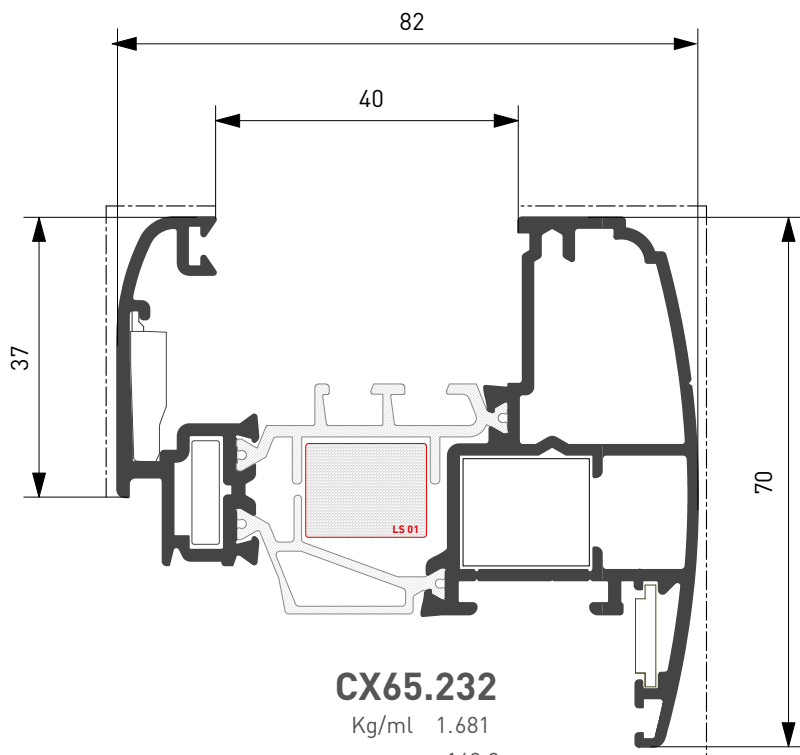

Profilato Profile	Squadretta esterna External Corner Joint				Squadretta interna Internal Corner Joint						Sq. Allineamento Alining Corner J.			
	Cianfrinare Riveting		Spinare Crimping		Bottone Slot	Cianfrinare Riveting	Spinare Crimping	Avvitare Screw		Esterna External	Interna Internal			
CX65.224	ARX.03.SQ	ARX.03.SQ + ARX.08.SQ		ACX.16.SQ	*AWX.19.SQ	+ ARX07.SQ + VIL M5x14 D8		ARX.15.SQ	ARX.10.SQ					
CX65.230	ARX.03.SQ	ARX.03.SQ + ARX.08.SQ		ACX.16.SQ	*AWX.19.SQ	+ ARX07.SQ + VIL M5x14 D8		ARX.15.SQ	ARX.10.SQ					
CX65.232	ARX.03.SQ	ARX.03.SQ + ARX.08.SQ		ACX.16.SQ	*AWX.19.SQ	+ ARX07.SQ + VIL M5x14 D8		ARX.15.SQ	ARX.10.SQ					
CX65.233	ARX.06.SQ	ARX.06.SQ + ARX.08.SQ			*AWX.17.SQ	+ ARX07.SQ + VIL M5x14 D8		ARX.15.SQ	ARX.10.SQ					

*Per spinatura aggiungere ARX07.SQ | Per avvitatura aggiungere VIL M5x14_D8 [Gruppo C]

*For crimping add ARX07.SQ | For Screw add VIL M5x14_D8 [Group C]

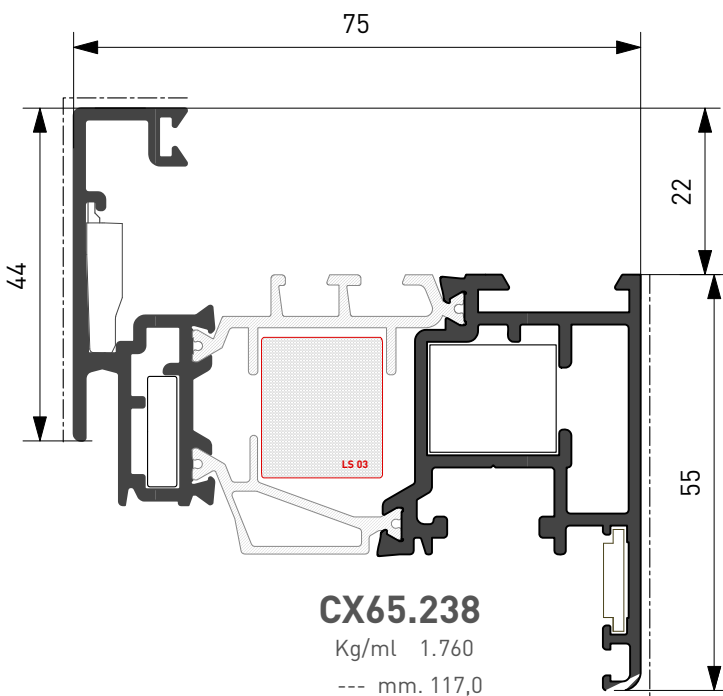
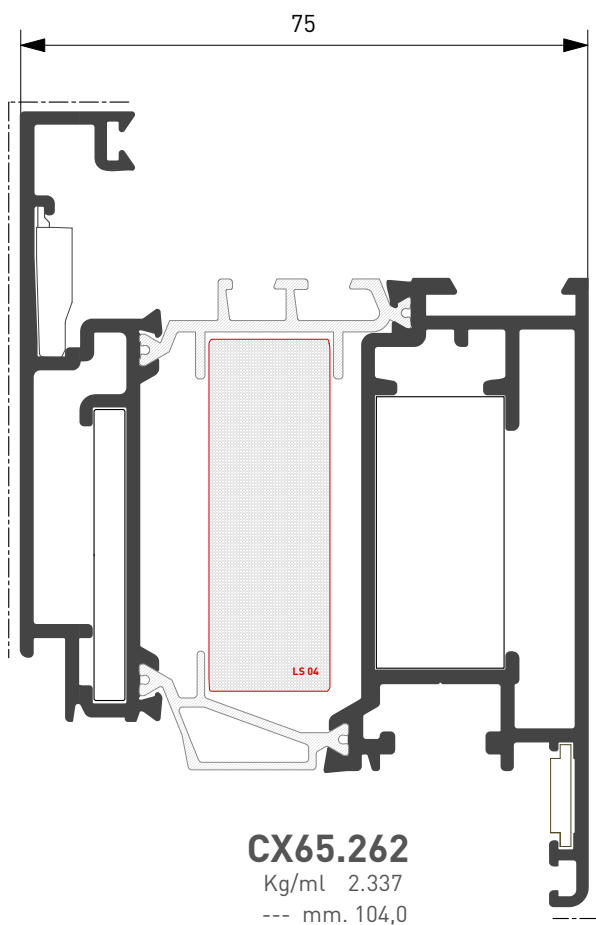
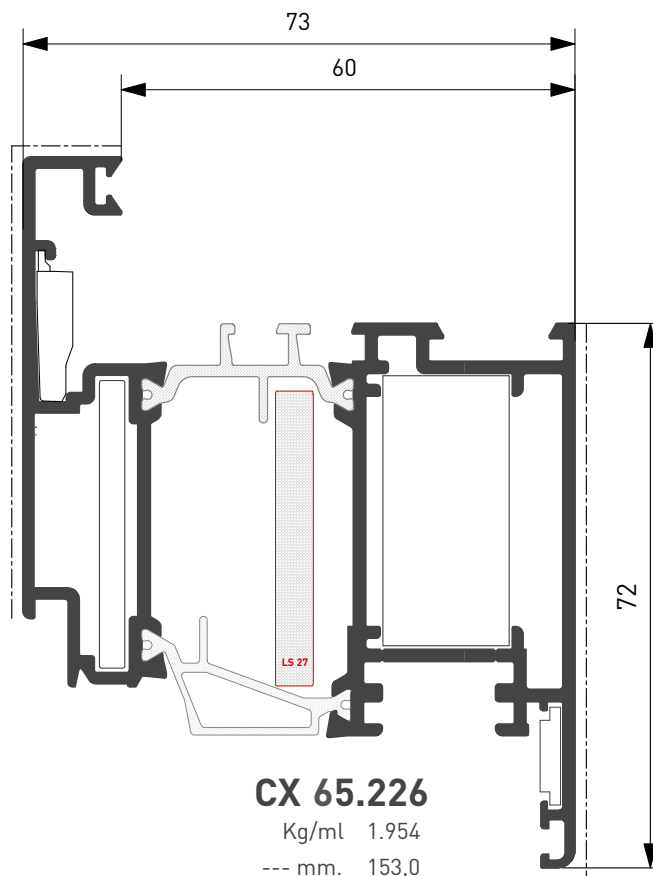
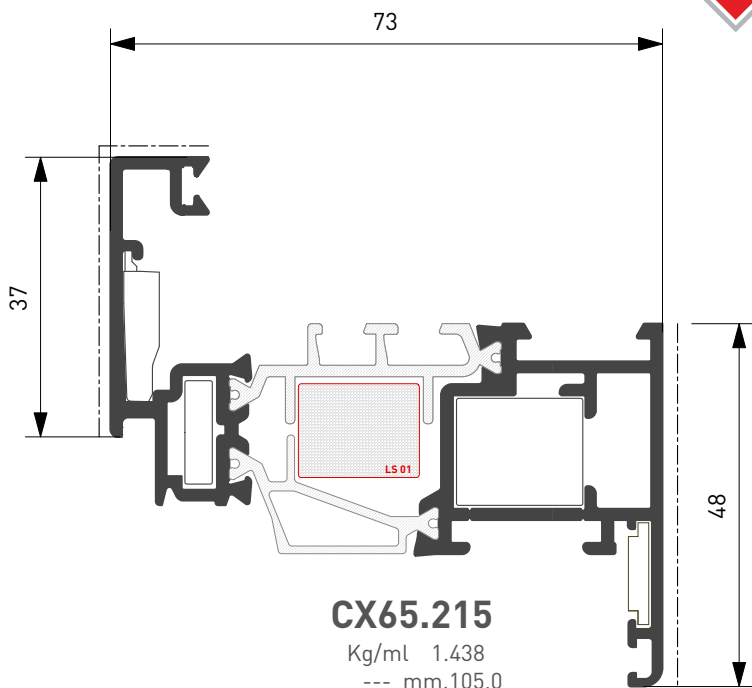

Profilato Profile	Squadretta esterna External Corner Joint		Squadretta interna Internal Corner Joint						Sq. Allineamento Alining Corner J.	
	Cianfrinare Riveting	Spinare Crimping	Bottone Slot	Cianfrinare Riveting	Spinare Crimping	Avvitare Screw	Esterna External	Interna Internal		
CX65.215	ARX.03.SQ	ARX.03.SQ + ARX.08.SQ	ACX.16.SQ	*AWX.19.SQ	+ ARX07.SQ + VIL M5x14 D8		ARX.15.SQ	ARX.10.SQ		
CX65.226	ARX.06.SQ	ARX.06.SQ + ARX.08.SQ		*AWX.17.SQ	+ ARX07.SQ + VIL M5x14 D8		ARX.15.SQ	ARX.10.SQ		
CX65.238	ARX.03.SQ	ARX.03.SQ + ARX.08.SQ	ACX.16.SQ	*AWX.19.SQ	+ ARX07.SQ + VIL M5x14 D8		ARX.15.SQ	ARX.10.SQ		
CX65.262	ARX.06.SQ	ARX.06.SQ + ARX.08.SQ		*AWX.17.SQ	+ ARX07.SQ + VIL M5x14 D8		ARX.15.SQ	ARX.10.SQ		

*Per spinatura aggiungere ARX07.SQ | Per avvitatura aggiungere VIL M5x14_D8 [Gruppo C]

*For crimping add ARX07.SQ | For Screw add VIL M5x14_D8 [Group C]

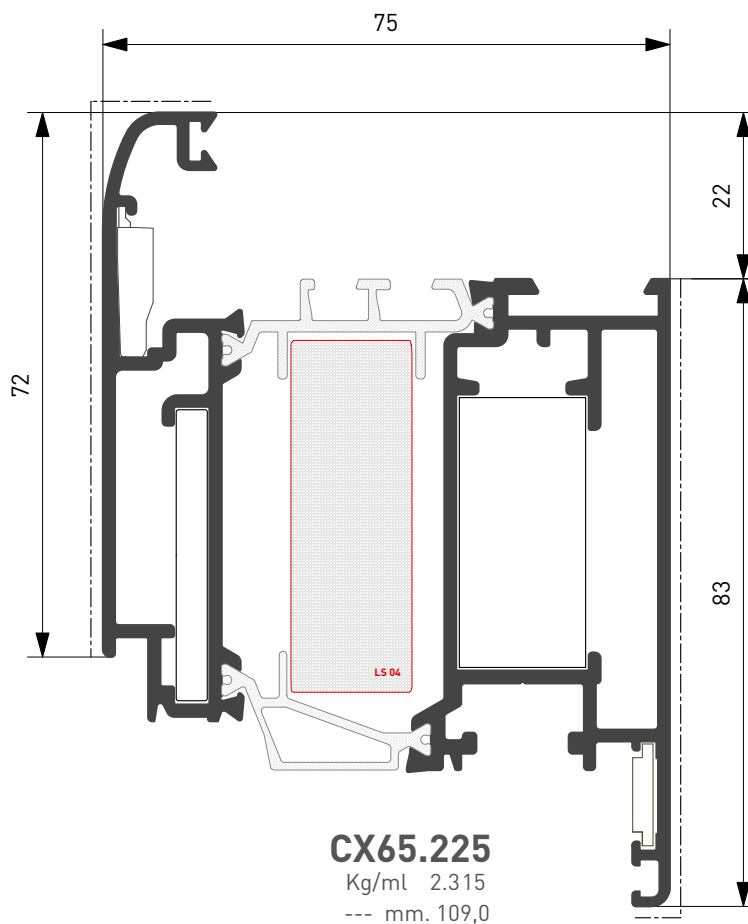
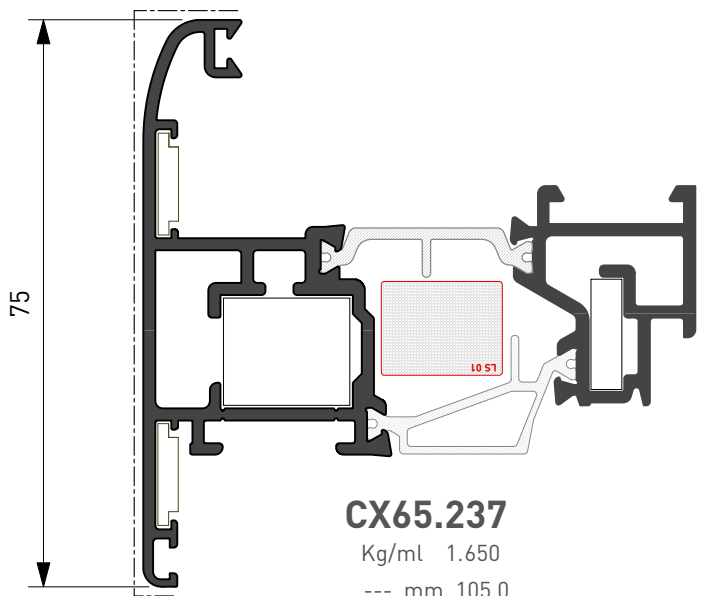

Profilato Profile	Squadretta esterna External Corner Joint		Squadretta interna Internal Corner Joint					Sq. Allineamento Alining Corner J.	
	Cianfrinare Riveting	Spinare Crimping	Bottone Slot	Cianfrinare Riveting	Spinare Crimping	Avvitare Screw	Esterna External	Interna Internal	
CX65.225	ARX.06.SQ	ARX.06.SQ + ARX.08.SQ		*AWX.17.SQ	+ ARX07.SQ	+ VIL M5x14 D8	ARX.15.SQ	ARX.10.SQ	
CX65.237	ARX.03.SQ	ARX.03.SQ + ARX.08.SQ	ACX.16.SQ	*AWX.19.SQ	+ ARX07.SQ	+ VIL M5x14 D8	ARX.10.SQ		

***Per spinatura aggiungere ARX07.SQ | Per avvitatura aggiungere VIL M5x14_D8 [Gruppo C]**
***For crimping add ARX07.SQ | For Screw add VIL M5x14_D8 [Group C]**

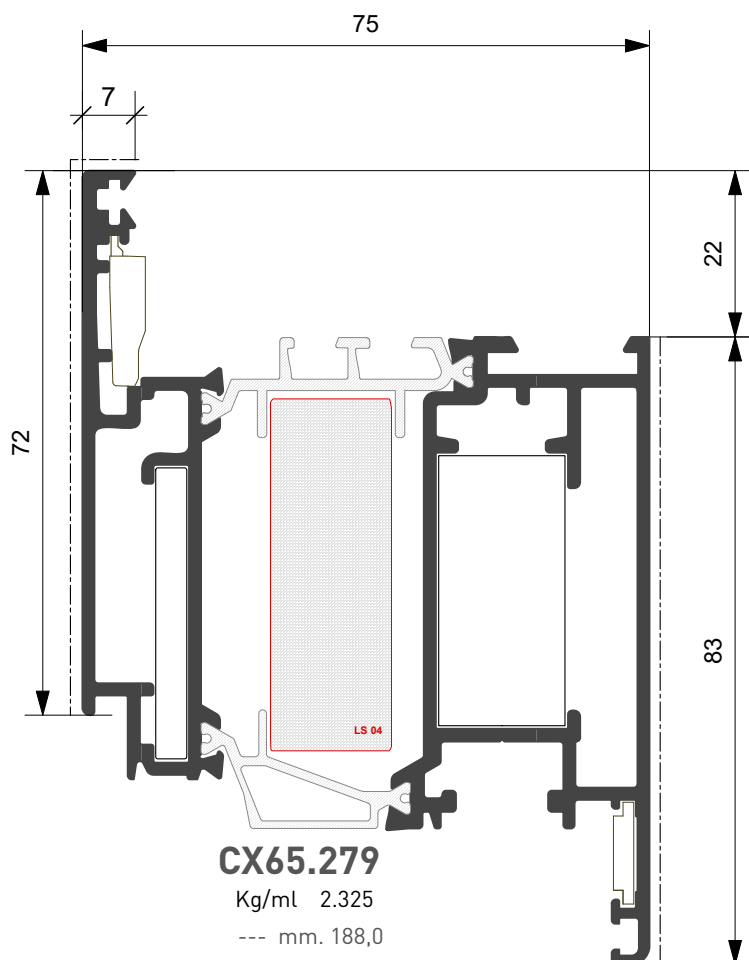
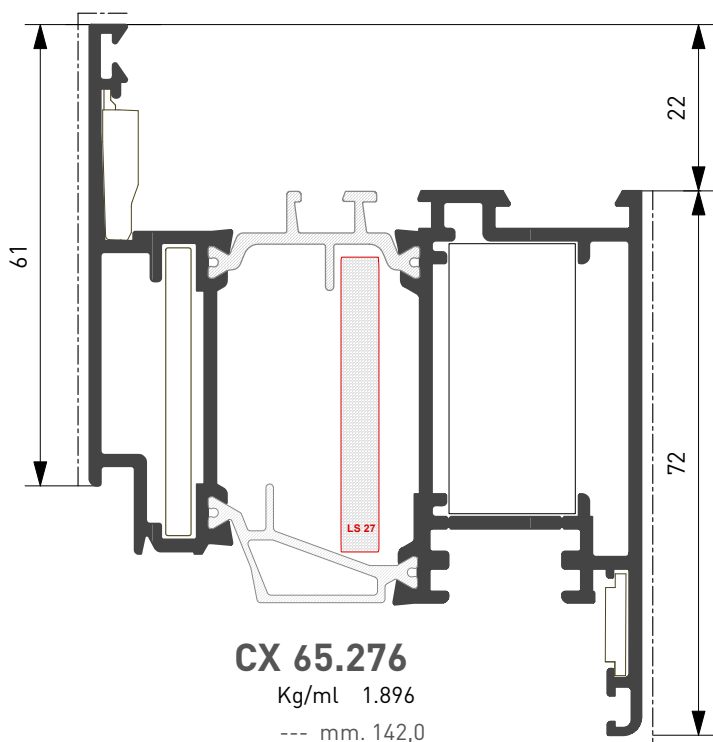
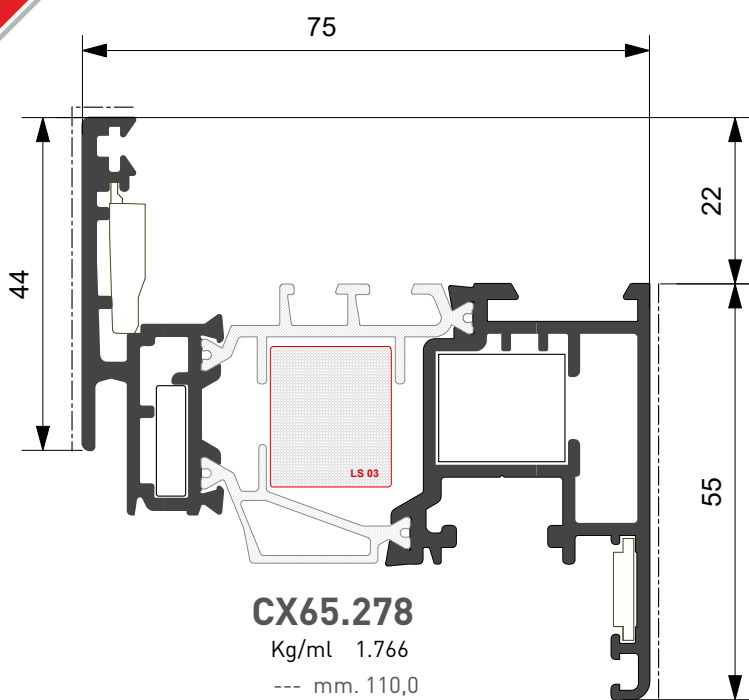
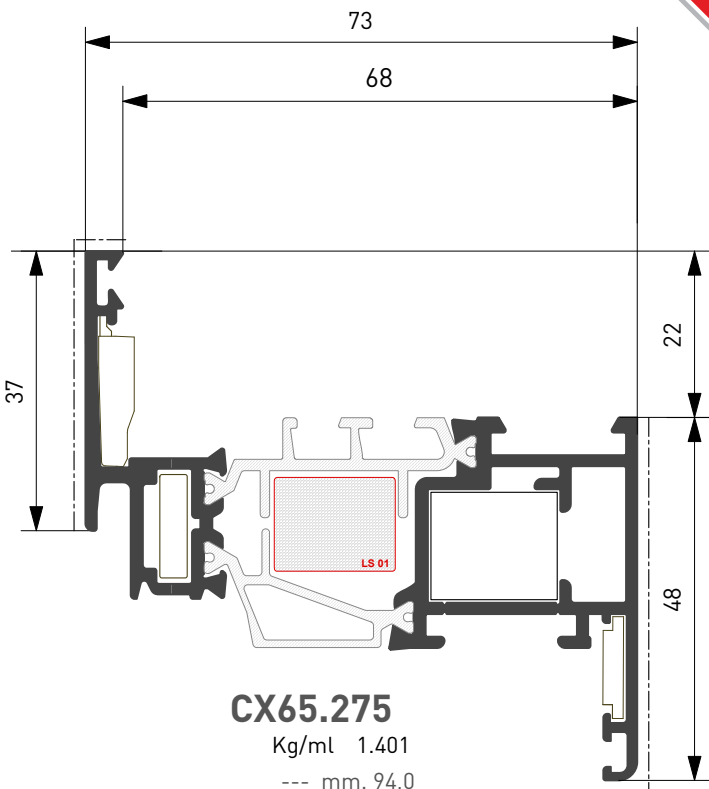

Profilato Profile	Squadretta esterna External Corner Joint		Squadretta interna Internal Corner Joint				Sq. Allineamento Alining Corner J.	
	Cianfrinare Riveting	Spinare Crimping	Bottone Slot	Cianfrinare Riveting	Spinare Crimping	Avvitare Screw	Esterna External	Interna Internal
CX65.275	ARX.03.SQ	ARX.03.SQ + ARX.08.SQ	ACX.16.SQ	*AWX.19.SQ	+ ARX07.SQ + VIL M5x14 D8		ARX.15.SQ	ARX.10.SQ
CX65.276	ARX.06.SQ	ARX.06.SQ + ARX.08.SQ		*AWX.17.SQ	+ ARX07.SQ + VIL M5x14 D8		ARX.15.SQ	ARX.10.SQ
CX65.278	ARX.03.SQ	ARX.03.SQ + ARX.08.SQ	ACX.16.SQ	*AWX.19.SQ	+ ARX07.SQ + VIL M5x14 D8		ARX.15.SQ	ARX.10.SQ
CX65.279	ARX.06.SQ	ARX.06.SQ + ARX.08.SQ		*AWX.17.SQ	+ ARX07.SQ + VIL M5x14 D8		ARX.15.SQ	ARX.10.SQ

*Per spinatura aggiungere ARX07.SQ | Per avvitatura aggiungere VIL M5x14_D8 [Gruppo C]

*For crimping add ARX07.SQ | For Screw add VIL M5x14_D8 [Group C]

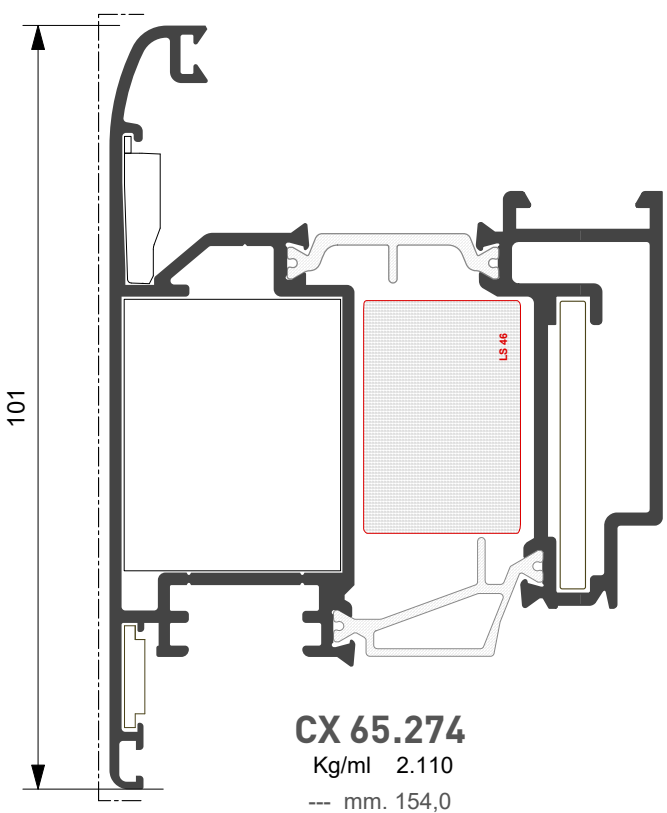
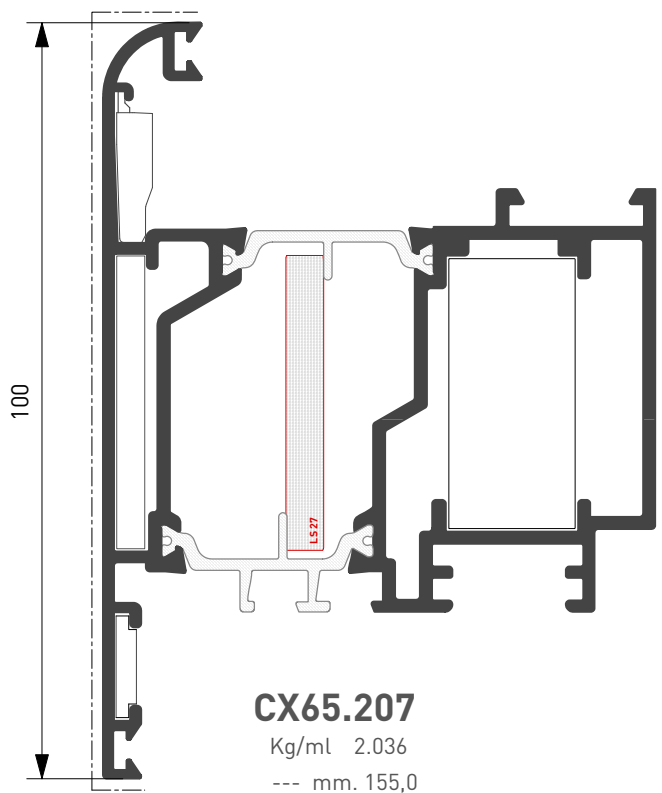
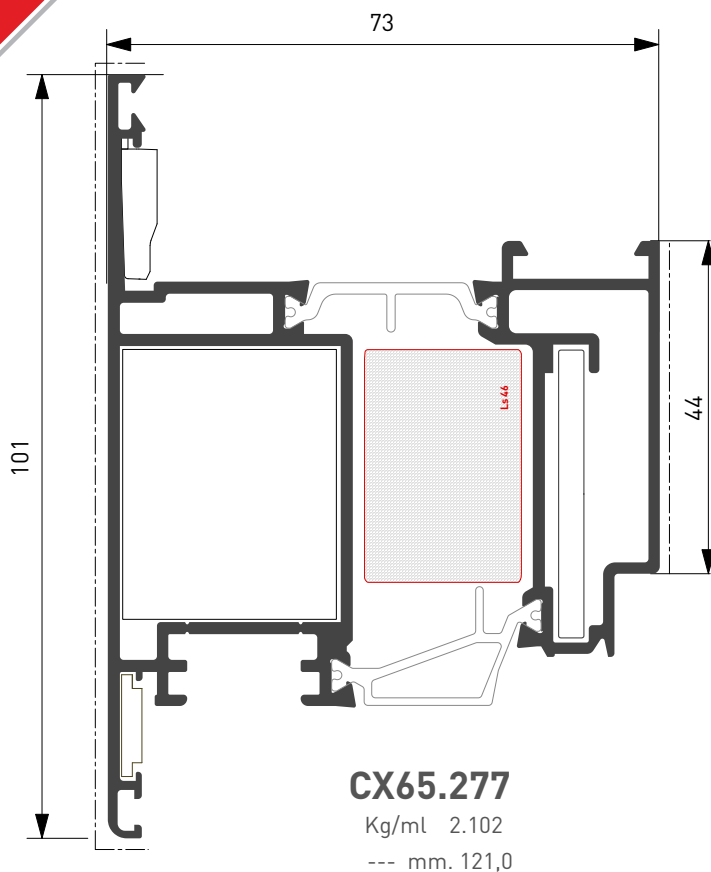
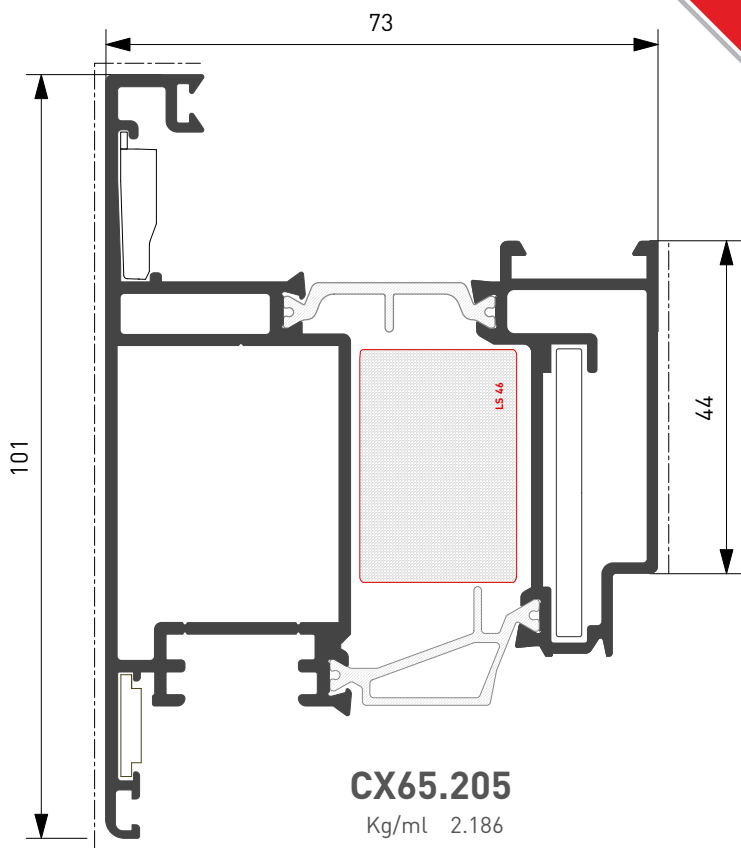

Profilato Profile	Squadretta esterna External Corner Joint				Squadretta interna Internal Corner Joint				Sq. Allineamento Alining Corner J.	
	Cianfrinare Riveting	Spinare Crimping	Avvitare Screw		Bottone Slot	Cianfrinare Riveting	Spinare Crimping	Avvitare Screw	Esterna External	Interna Internal
CX65.205	ACX.14.SQ	+ ARX.07.SQ	+VILM 5x14 D8			*ARX.06.SQ	+ ARX07.SQ		ARX.10 e 15.SQ	
CX65.207	ARX.06.SQ	+ ARX.08.SQ				*AWX.17.SQ	+ ARX07.SQ + VIL M5x14 D8		ARX.10 e 15.SQ	
CX65.274	ACX.14.SQ	+ ARX.07.SQ	+VILM 5x14 D8			*ARX.06.SQ	+ ARX07.SQ		ARX.10 e 15.SQ	
CX65.277	ACX.14.SQ	+ ARX.07.SQ	+VILM 5x14 D8			*ARX.06.SQ	+ ARX07.SQ		ARX.10 e 15.SQ	

*Per spinatura aggiungere ARX07.SQ | Per avvitatura aggiungere VIL M5x14_D8 [Gruppo C]

*For crimping add ARX07.SQ | For Screw add VIL M5x14_D8 [Group C]

FERRAMENTA A NASTRO
TAPE HARDWARE

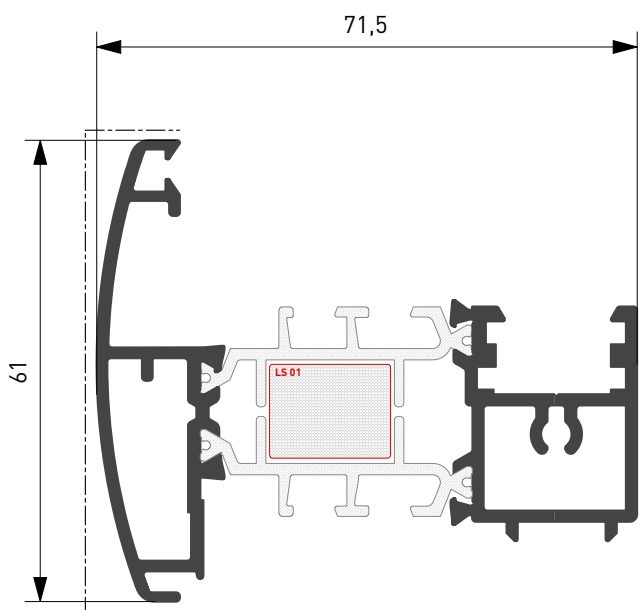

CX65.301

Kg/ml 1.379
--- mm. 111,0

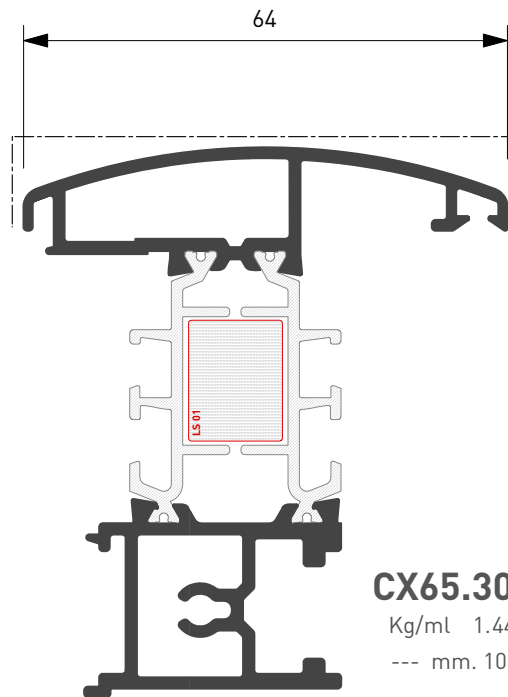

CX65.302

Kg/ml 1.442
--- mm. 106,0

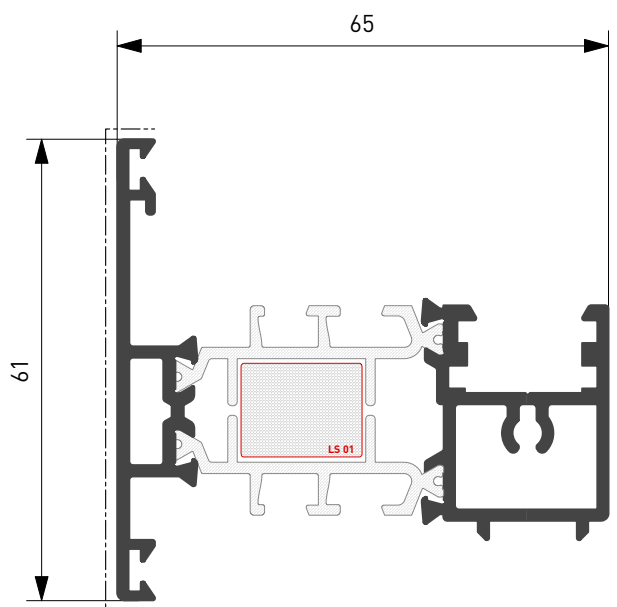

CX65.304

Kg/ml 1.298
--- mm. 108,0

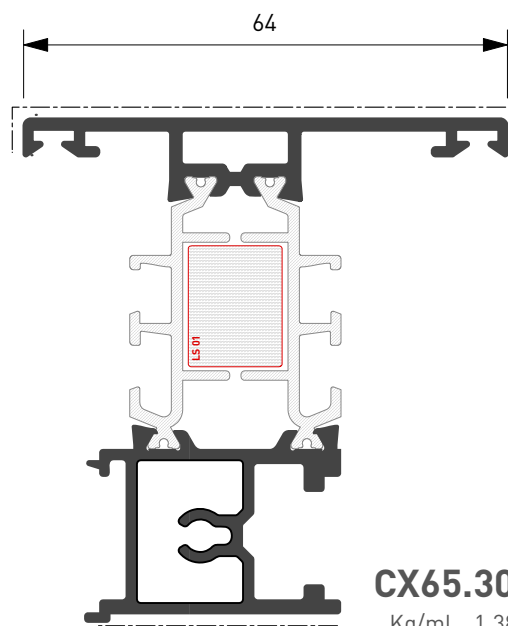

CX65.308

Kg/ml 1.389
--- mm. 101,0

Profilato Profile	Squadretta esterna External Corner Joint				Squadretta interna Internal Corner Joint						Sq. Allineamento Alining Corner J.			
	Cianfrinare Riveting		Spinare Crimping		Bottone Slot	Cianfrinare Riveting		Spinare Crimping		Avvitare Screw		Esterna External		Interna Internal

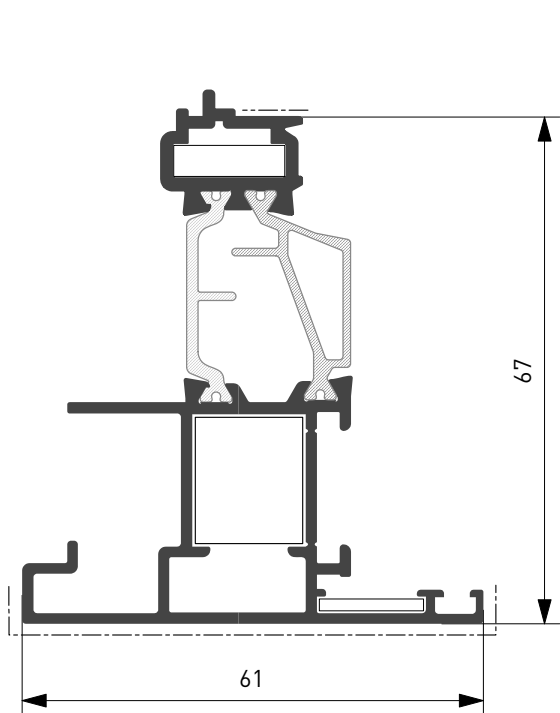

CX65.303
Kg/ml 1.253
--- mm. 64,0

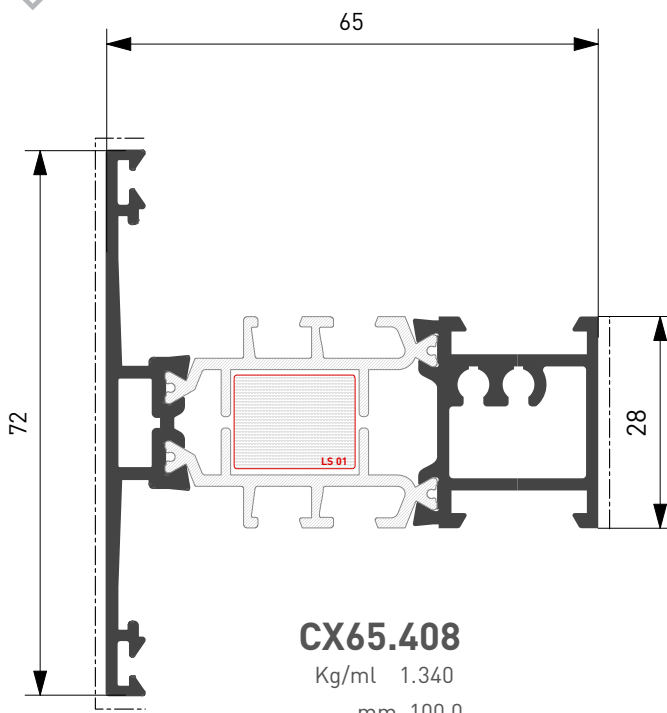

CX65.408
Kg/ml 1.340
--- mm. 100,0

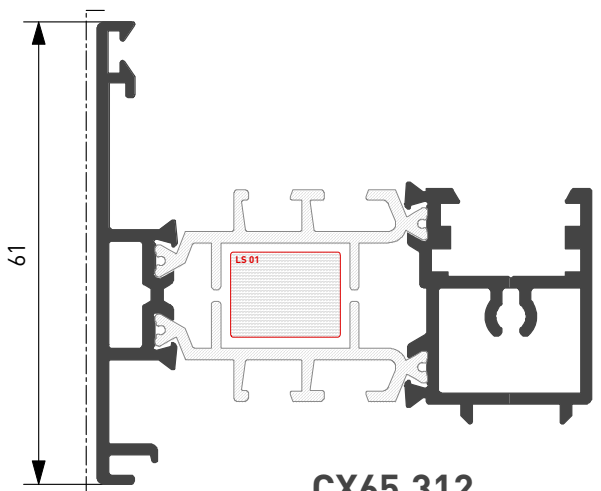

CX65.312
Kg/ml 1.308
--- mm. 154,0

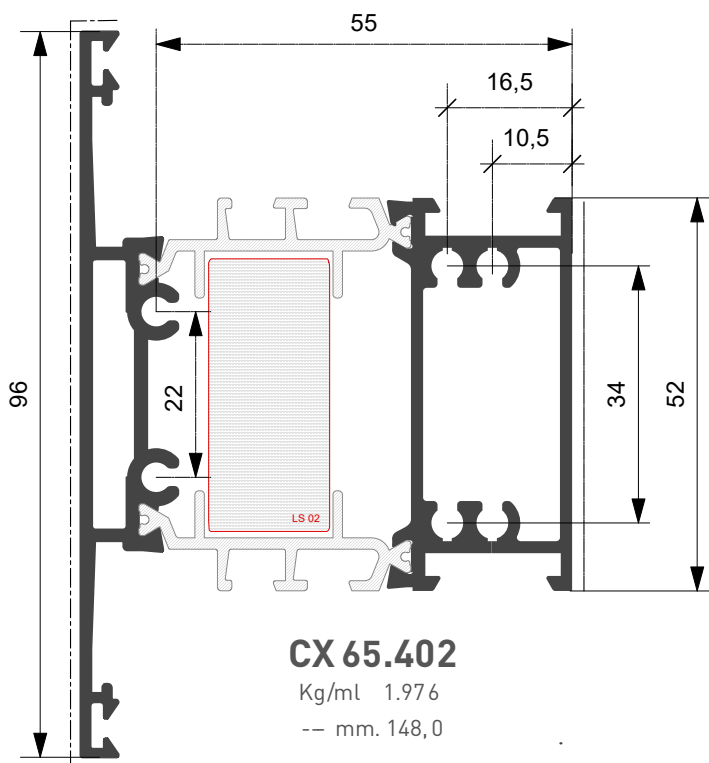

CX 65.402
Kg/ml 1.976
-- mm. 148,0

Profilato Profile	Squadretta esterna External Corner Joint				Squadretta interna Internal Corner Joint						Sq. Allineamento Alining Corner J.			
	Cianfrinare Riveting	Spinare Crimping	Bottone Slot	Avvitare Screw	Cianfrinare Riveting	Spinare Crimping	Avvitare Screw	Esterna External	Interna Internal	Esterna External	Interna Internal	Esterna External	Interna Internal	
CX65.303	ARX.03.SQ	*ARX.03.SQ + ARX.08.SQ	ACX.16.SQ	*AWX.19.SQ + ARX07.SQ + VILM 5x14 D8									ARX.10.SQ	

***Per spinatura aggiungere ARX07.SQ | Per avvitatura aggiungere VIL M5x14_D8 [Gruppo C]**
***For crimping add ARX07.SQ | For Screw add VIL M5x14_D8 [Group C]**

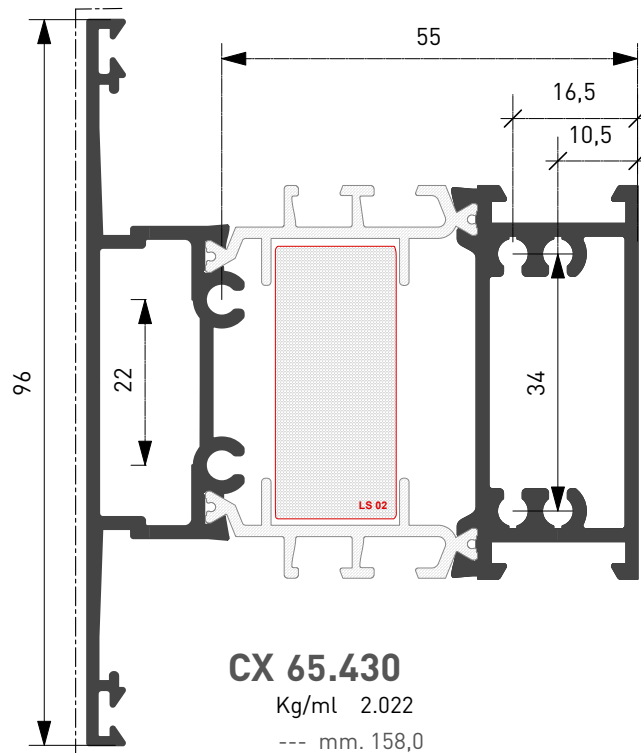
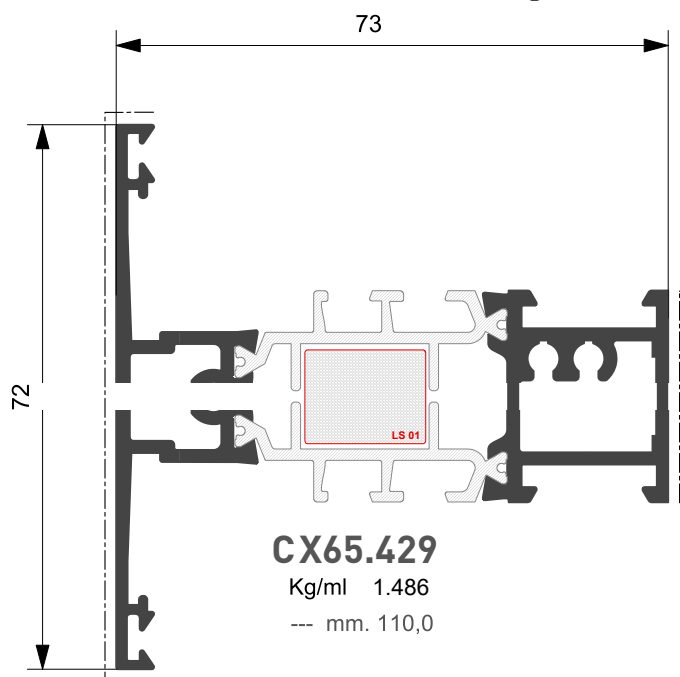
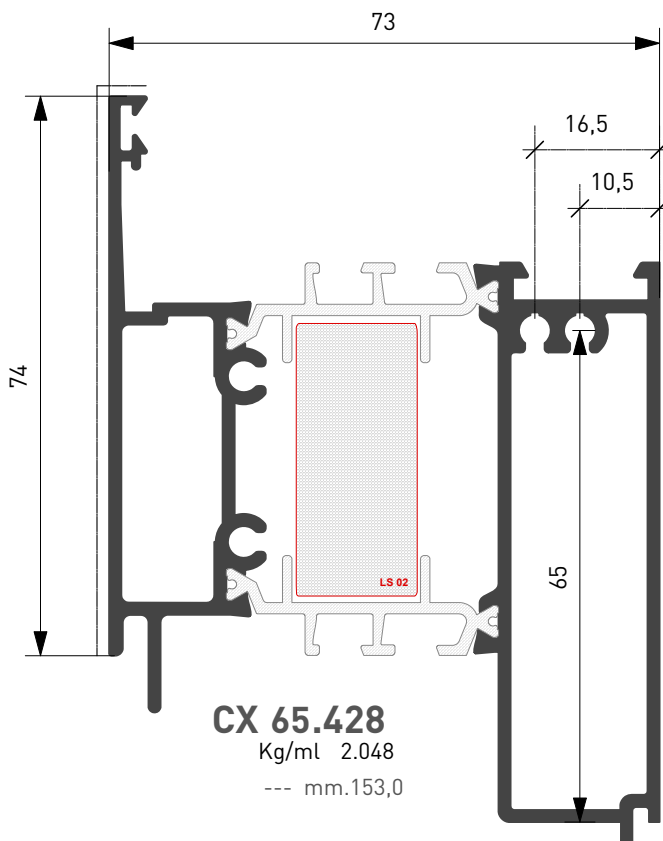
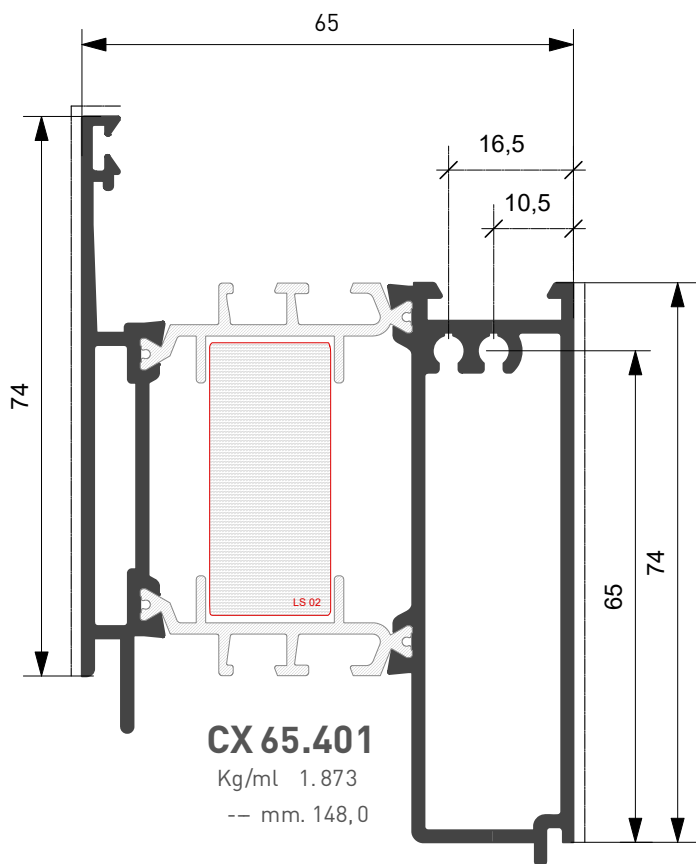

Profilato Profile	Squadretta esterna External Corner Joint				Squadretta interna Internal Corner Joint						Sq. Allineamento Alining Corner J.			
	Cianfrinare Riveting		Spinare Crimping		Bottone Slot	Cianfrinare Riveting	Spinare Crimping	Avvitare Screw		Esterna External	Interna Internal			

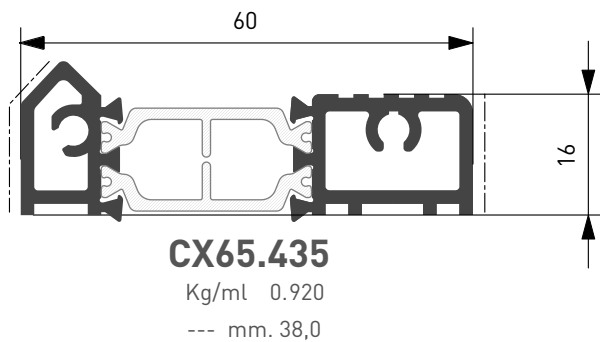
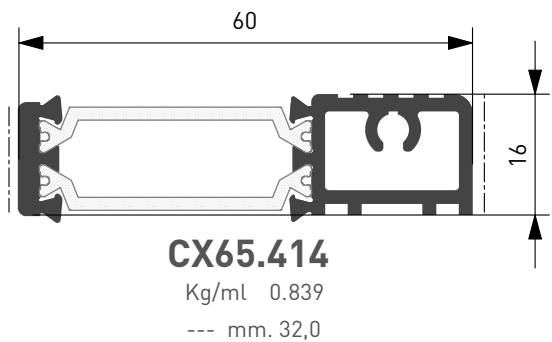
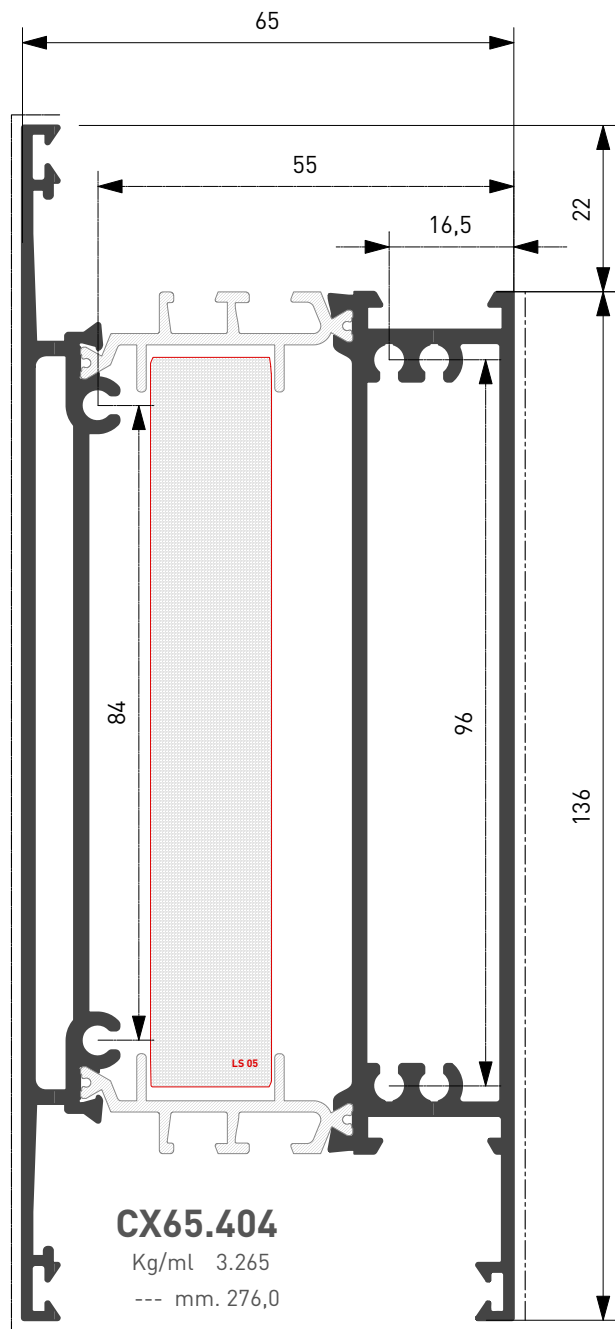
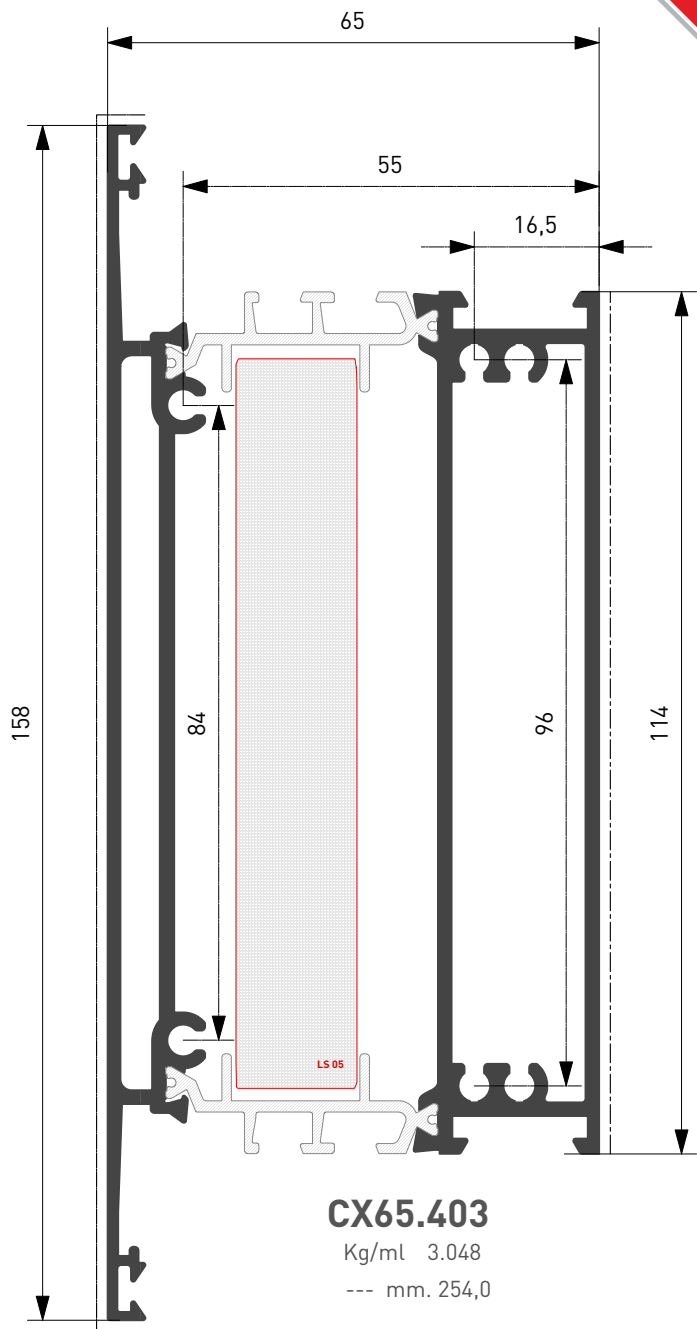

Profilato Profile	Squadretta esterna External Corner Joint				Squadretta interna Internal Corner Joint						Sq. Allineamento Alining Corner J.			
	Cianfrinare Riveting		Spinare Crimping		Bottone Slot	Cianfrinare Riveting	Spinare Crimping		Avvitare Screw		Esterna External		Interna Internal	

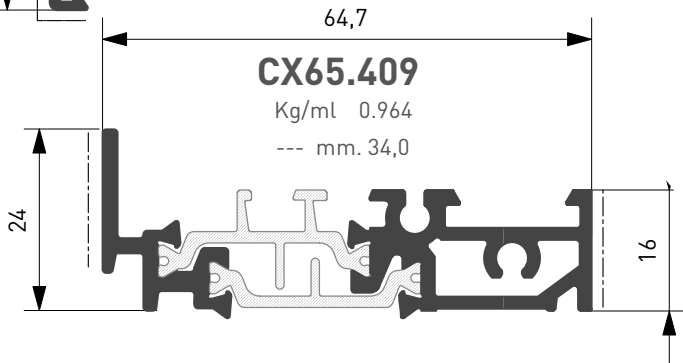
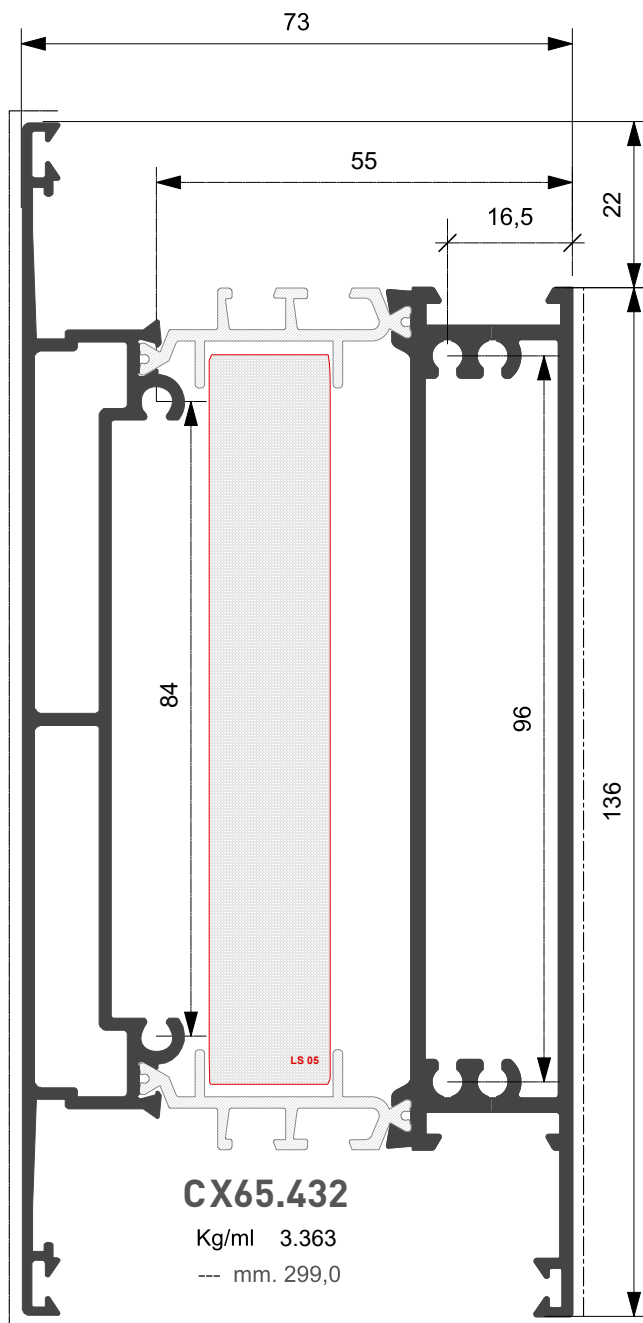
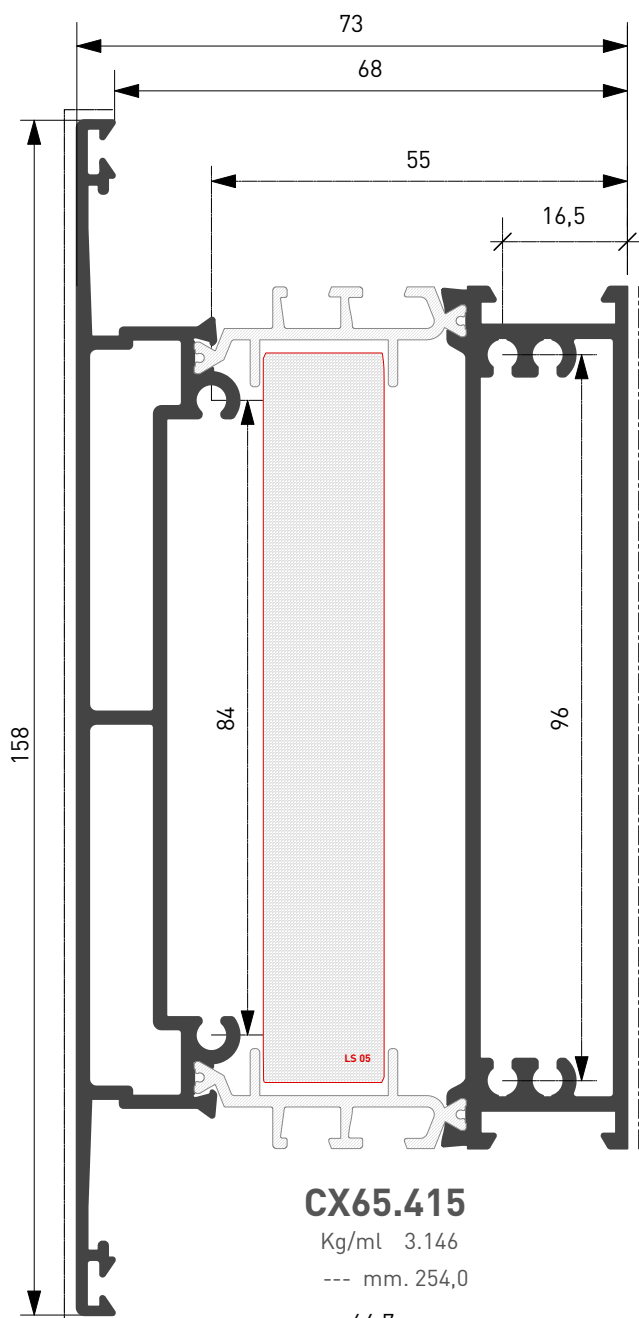

Profilato Profile	Squadretta esterna External Corner Joint				Squadretta interna Internal Corner Joint					Sq. Allineamento Alining Corner J.			
	Cianfrinare Riveting	Spinare Crimping	Bottone Slot	Cianfrinare Riveting	Spinare Crimping	Avvitare Screw	Esterna External	Interna Internal	Esterna External	Interna Internal			

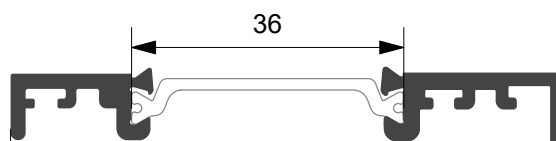
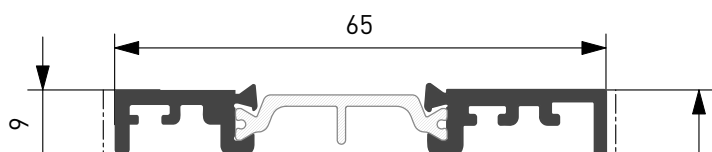
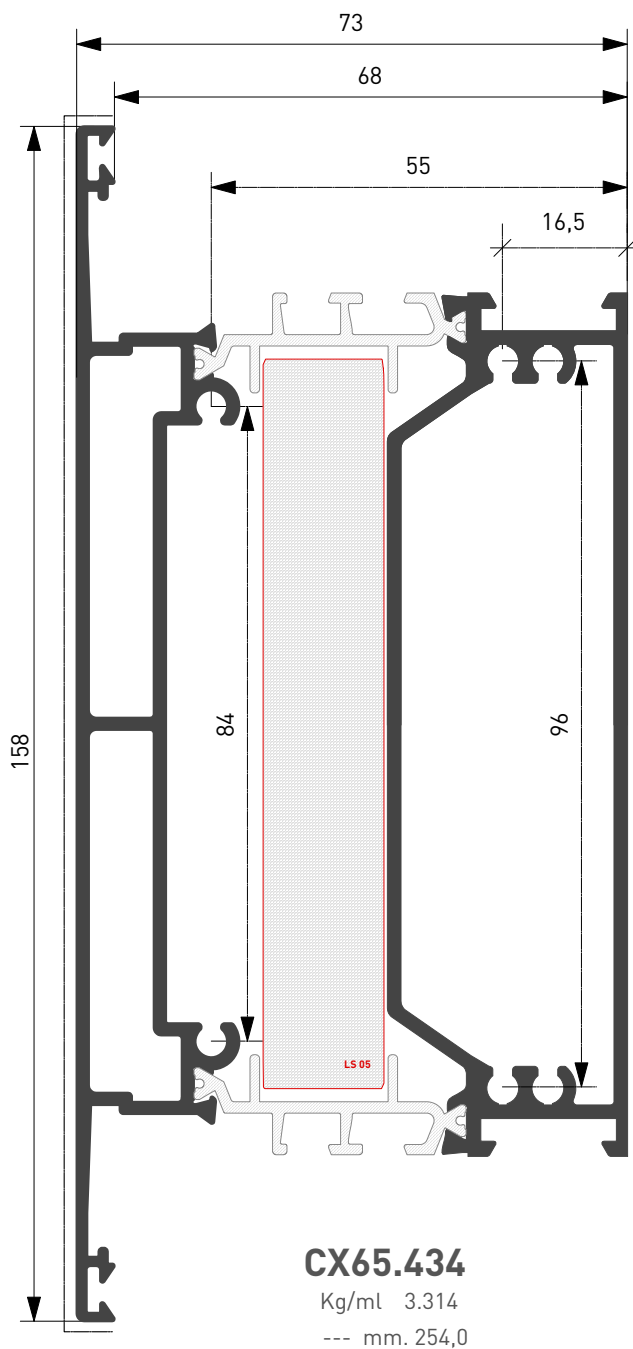
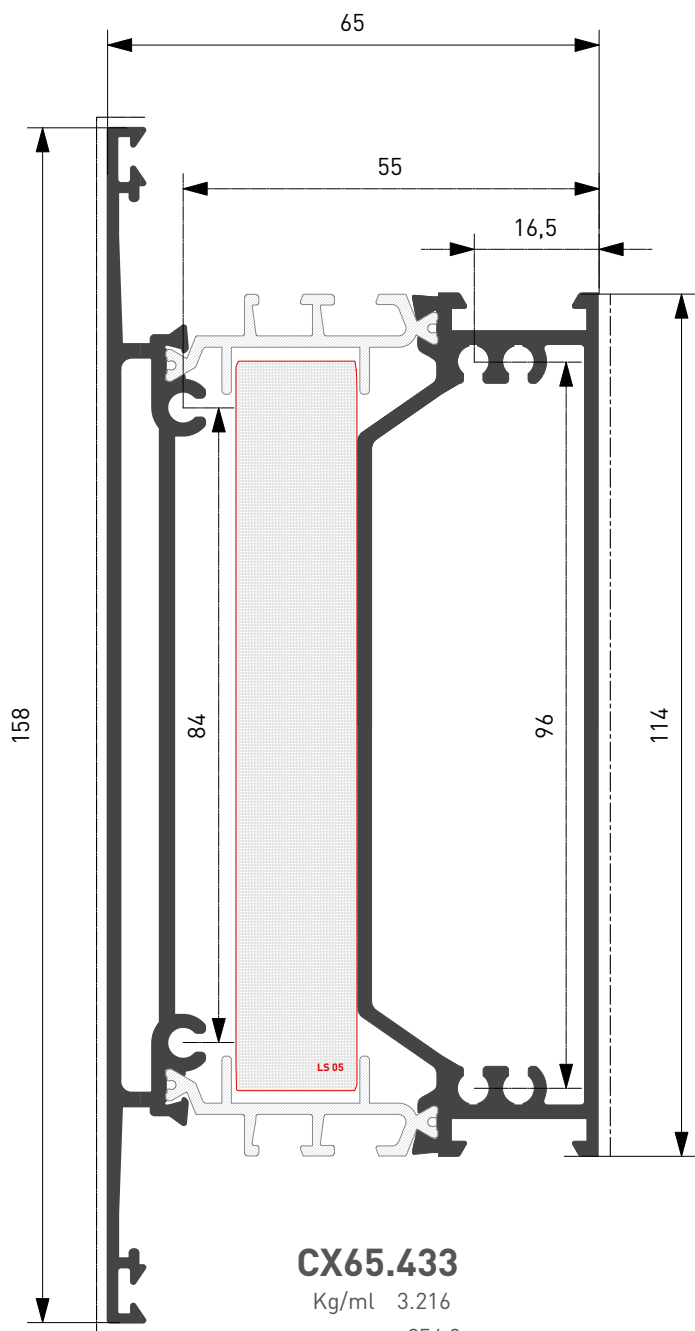

Profilato Profile	Squadretta esterna External Corner Joint				Squadretta interna Internal Corner Joint						Sq. Allineamento Alining Corner J.			
	Cianfrinare Riveting		Spinare Crimping		Bottone Slot	Cianfrinare Riveting	Spinare Crimping	Avvitare Screw		Esterna External	Interna Internal			

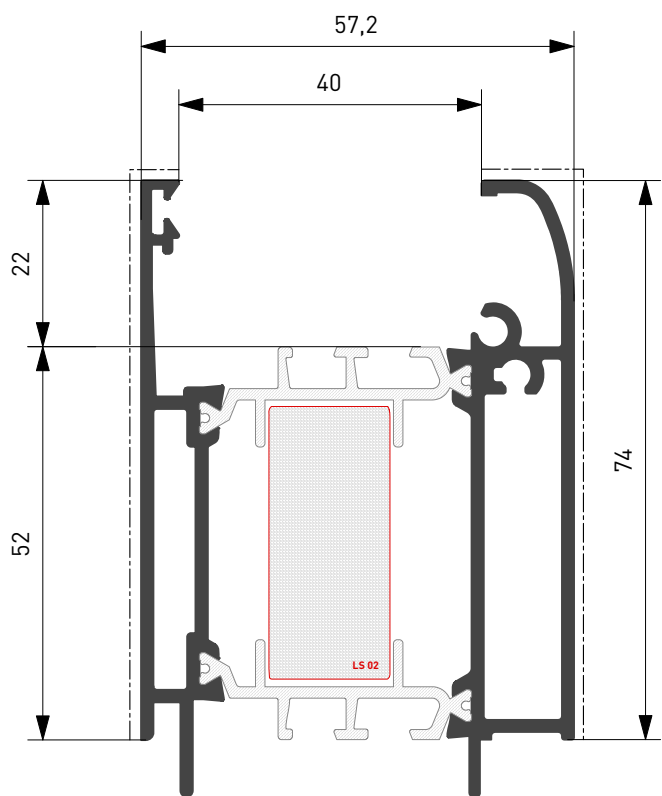

CX65.407
Kg/ml 1.736
--- mm. 162,0

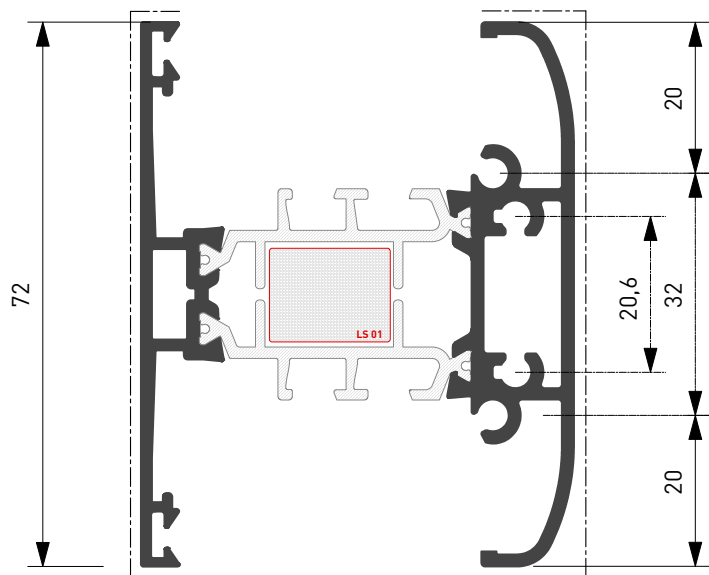

CX65.405
Kg/ml 1.574
--- mm. 1700

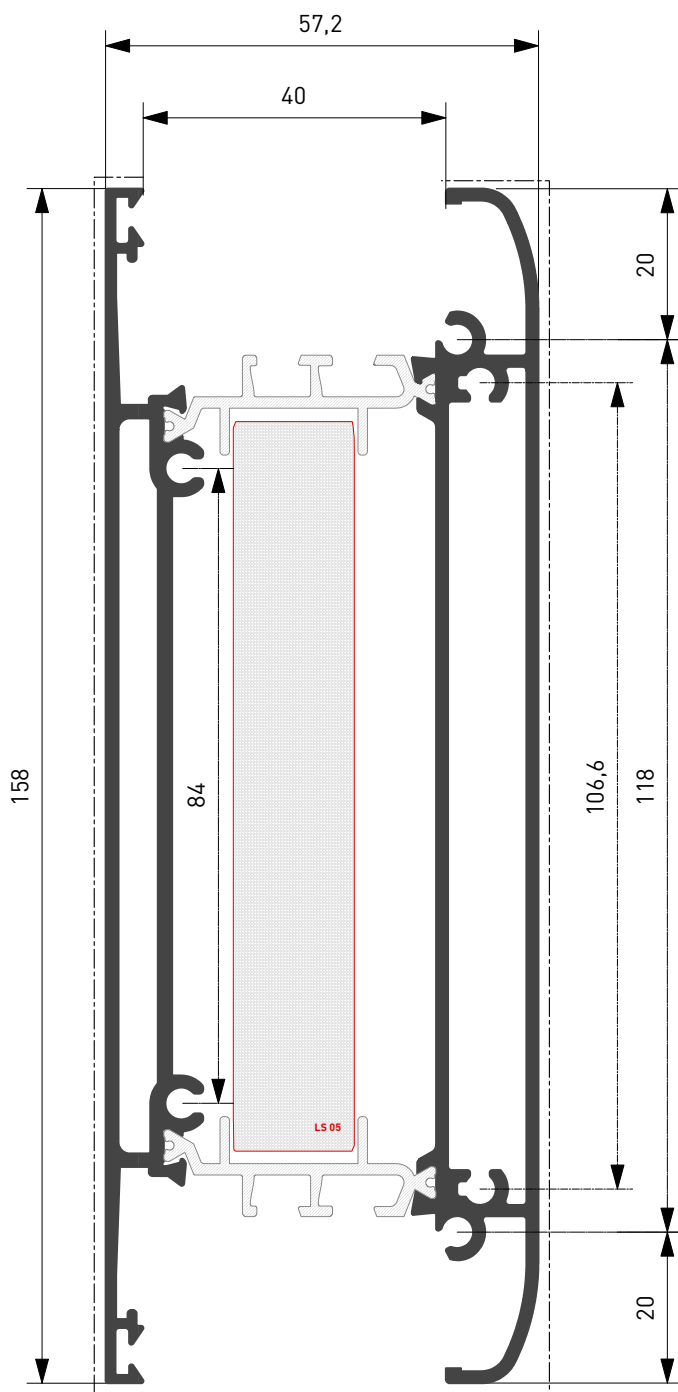

CX65.406
Kg/ml 3.193
--- mm. 332,0

Profilato Profile	Squadretta esterna External Corner Joint				Squadretta interna Internal Corner Joint						Sq. Allineamento Alining Corner J.			
	Cianfrinare Riveting		Spinare Crimping		Bottone Slot	Cianfrinare Riveting		Spinare Crimping		Avvitare Screw		Esterna External		Interna Internal

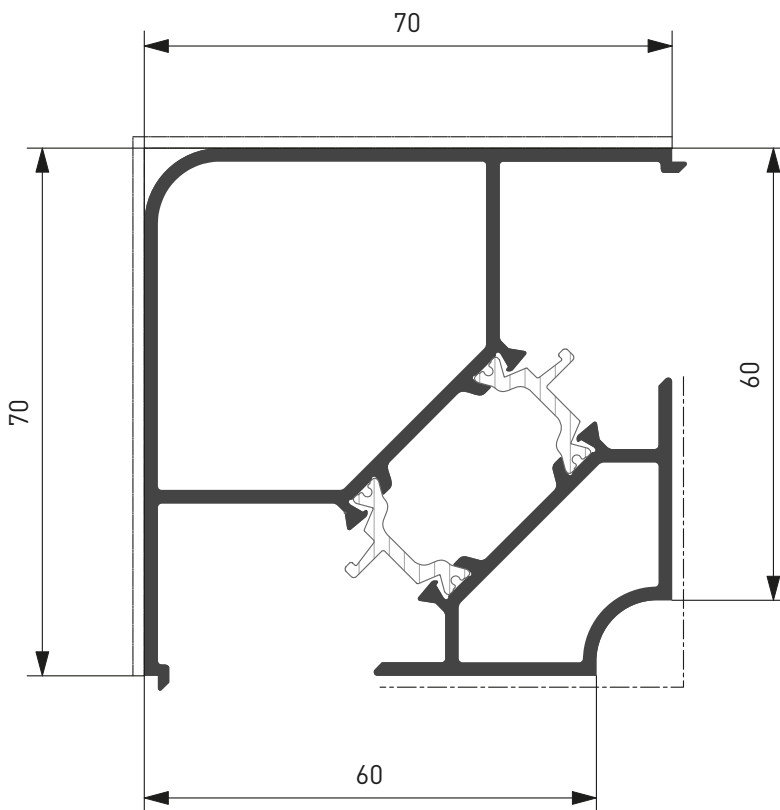

XX70.613

Kg/ml 1.861
--- mm. 215,0

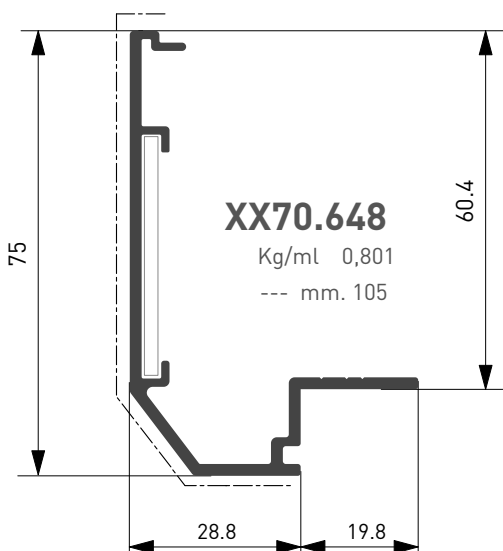

XX70.648

Kg/ml 0,801
--- mm. 105

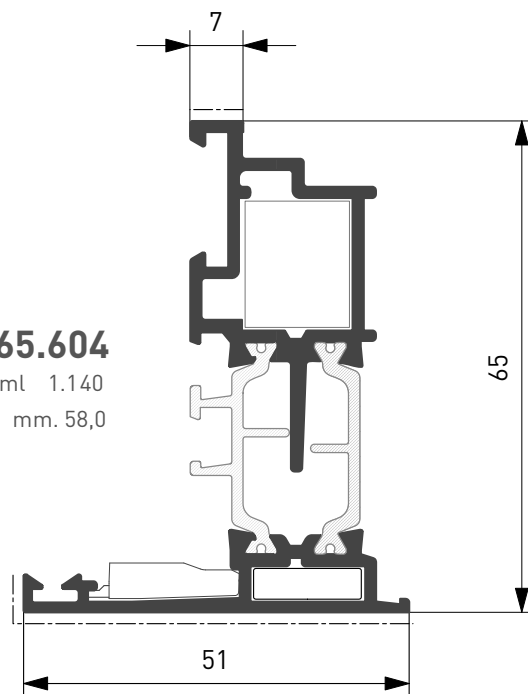

CX65.604

Kg/ml 1.140
--- mm. 58,0

Profilato Profile	Squadretta esterna External Corner Joint				Squadretta interna Internal Corner Joint							Sq. Allineamento Alining Corner J.			
	Cianfrinare Riveting		Spinare Crimping		Bottone Slot	Cianfrinare Riveting	Spinare Crimping	Avvitare Screw		Esterna External	Interna Internal				
CX65.604	ARX.03.SQ	ARX.06.SQ + ARX.08.SQ		ACX.16.SQ	*AWX.19.SQ + ARX07.SQ + VIL M5x14 D8							ARX.15.SQ			
XX70.648												ARX.71.SQ			

***Per spinatura aggiungere ARX07.SQ | Per avvitatura aggiungere VIL M5x14_D8 [Gruppo C]**
***For crimping add ARX07.SQ | For Screw add VIL M5x14_D8 [Group C]**

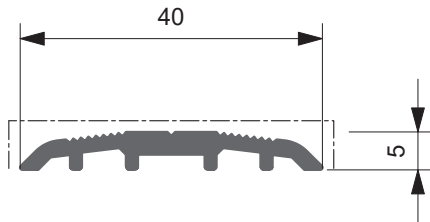

XX70.603

Kg/ml 0,276
--- mm. 40,0

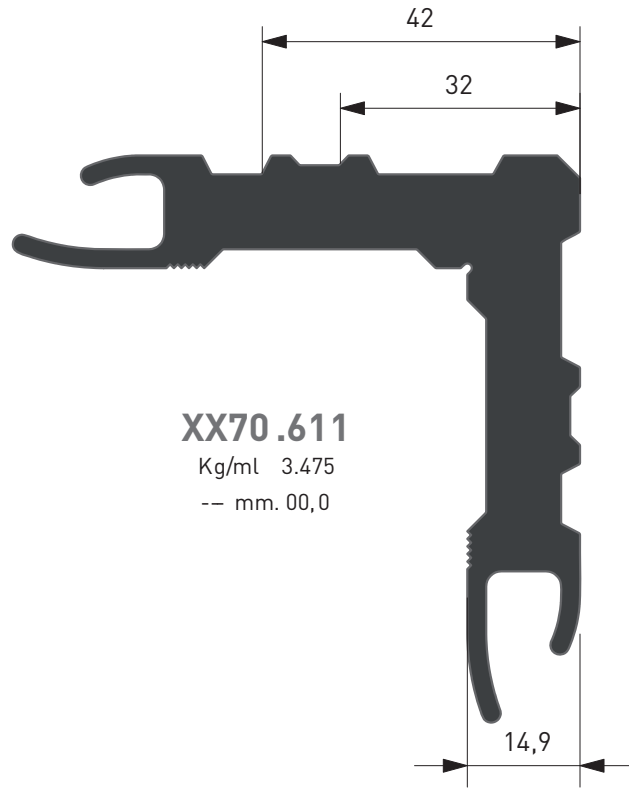

XX70.611

Kg/ml 3,475
--- mm. 00,0

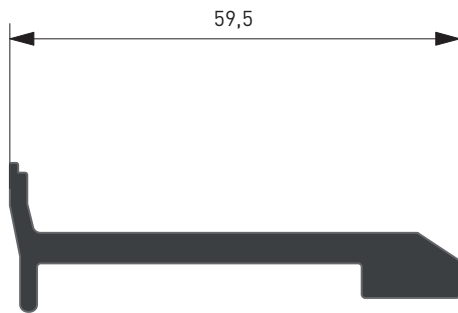

CX65.640

Kg/ml 0,861
--- mm. 0,0

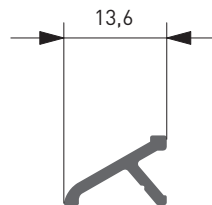

XX70.2040

Kg/ml 0,095
--- mm. 14,0



CX70.605

Kg/ml 0,146
--- mm. 14,0

Profilato Profile	Squadretta esterna External Corner Joint				Squadretta interna Internal Corner Joint						Sq. Allineamento Alining Corner J.			
	Cianfrinare Riveting		Spinare Crimping		Bottone Slot	Cianfrinare Riveting		Spinare Crimping		Avvitare Screw		Esterna External		Interna Internal

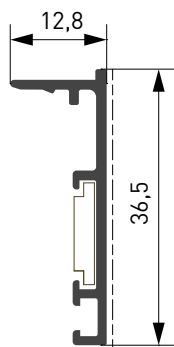

XX70.503
Kg/ml 0.224
--- mm. 42,0

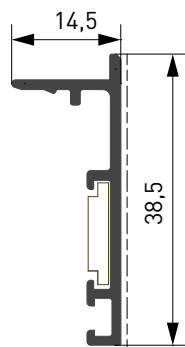

XX70.504
Kg/ml 0.238
--- mm. 44,0

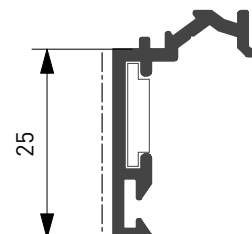

XX70.612
Kg/ml 0.248
--- mm. 25,0

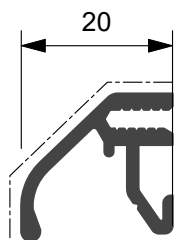

XX70.601
Kg/ml 0.270
--- mm. 28,0

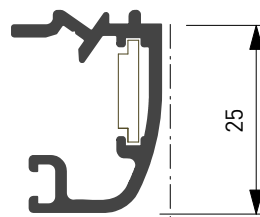

XX60.635
Kg/ml 0.306
--- mm. 41,0

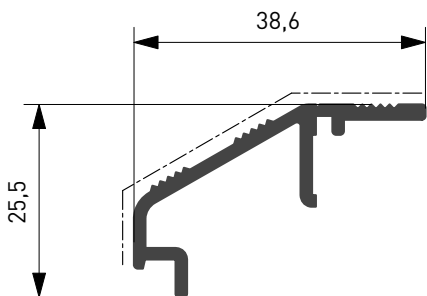

XX70.606
Kg/ml 0.322
--- mm. 50,0

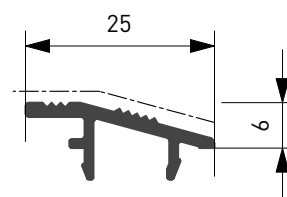

CX65.607
Kg/ml 0.224
--- mm. 32,0

Profilato Profile	Squadretta esterna External Corner Joint				Squadretta interna Internal Corner Joint						Sq. Allineamento Alining Corner J.			
	Cianfrinare Riveting		Spinare Crimping		Bottone Slot	Cianfrinare Riveting		Spinare Crimping		Avvitare Screw		Esterna External		Interna Internal
XX60.635											ARX.10.SQ			
XX70.503												ARX.10.SQ		
XX70.504												ARX.10.SQ		
XX70.612											ARX.10.SQ			

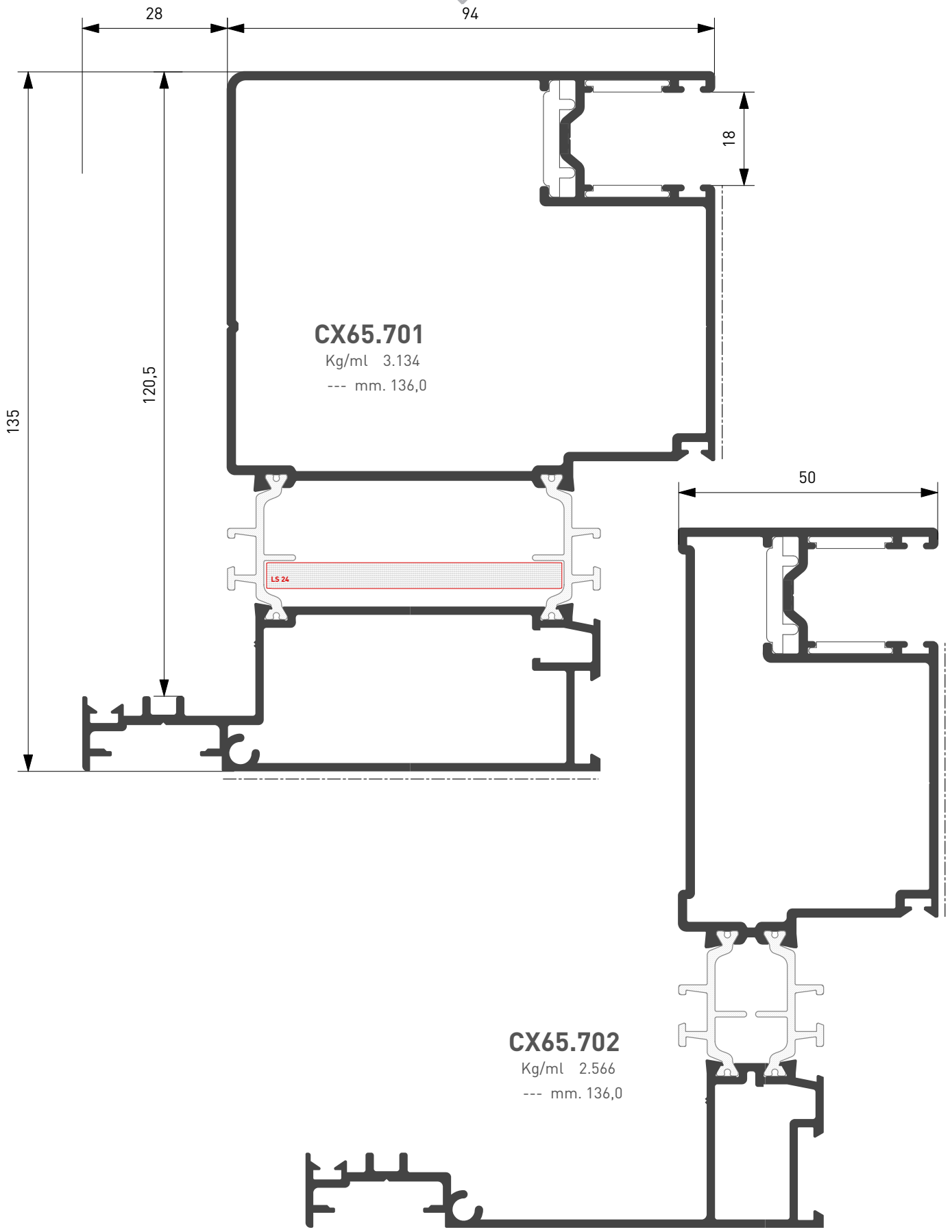

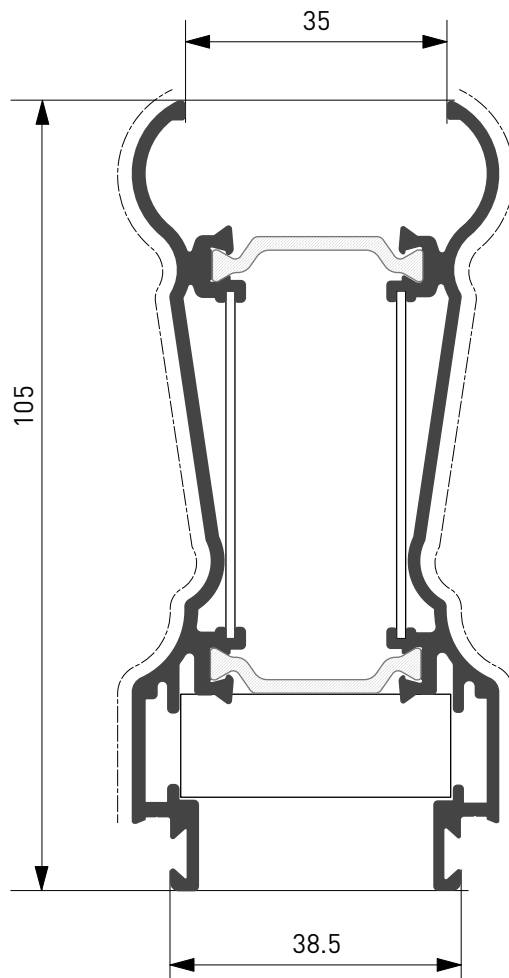
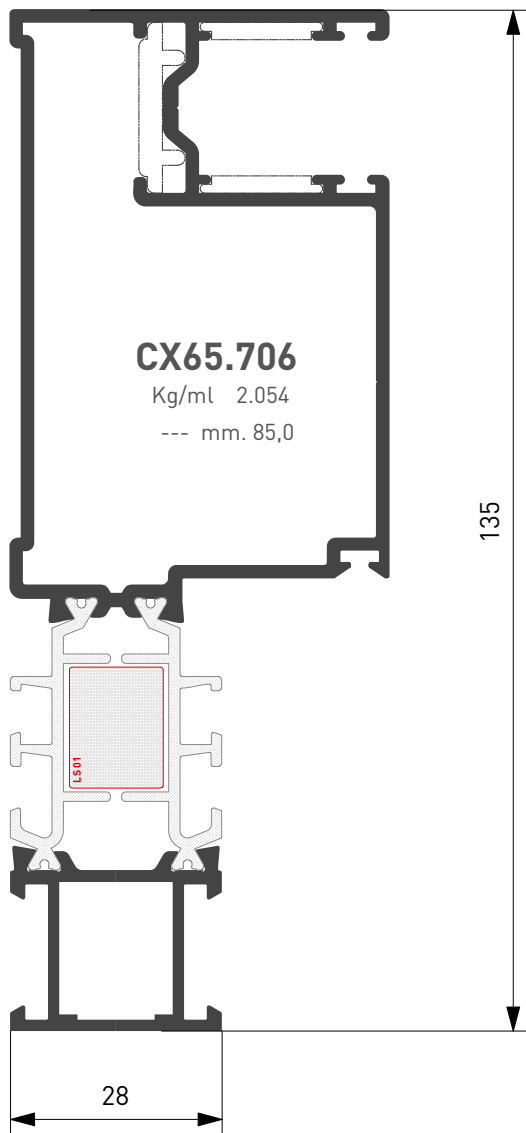

XX70.636
Kg/ml 1.674
--- mm. 214,0

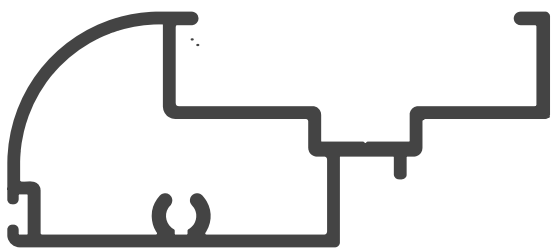

XX70.703
Kg/ml 0.832
--- mm. 43,0



XX70.705
Kg/ml 0.155
--- mm. 000,0

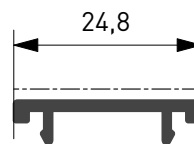

XX70.704
Kg/ml 0.135
--- mm. 25,0

Profilato Profile	Squadretta esterna External Corner Joint				Squadretta interna Internal Corner Joint						Sq. Allineamento Alining Corner J.			
	Cianfrinare Riveting		Spinare Crimping		Bottone Slot	Cianfrinare Riveting	Spinare Crimping	Avvitare Screw		Esterna External	Interna Internal			
XX70.636					ACX.72.SQ					ACX.73.SQ	ACX.73.SQ			

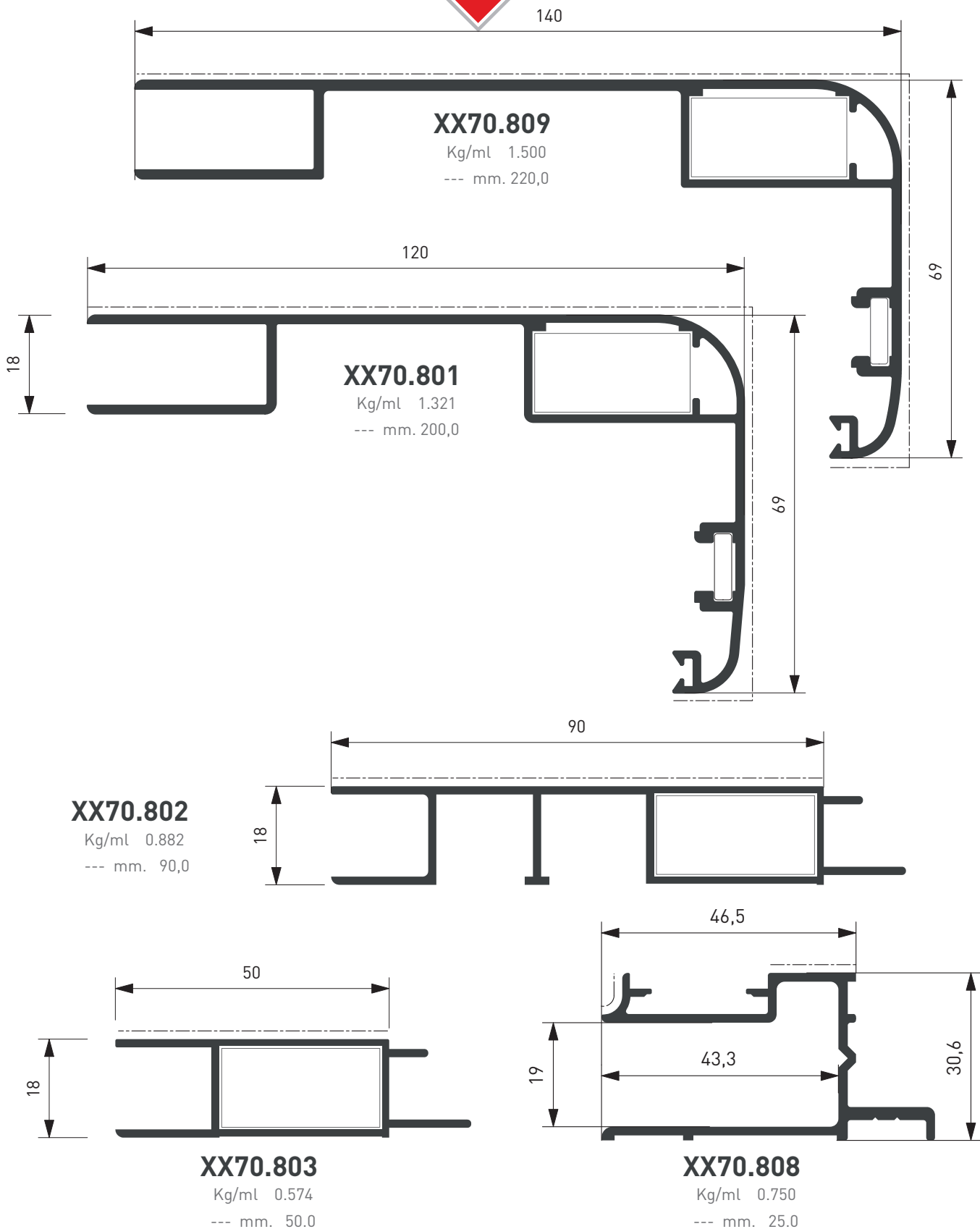

Profilato Profile	Squadretta esterna External Corner Joint				Squadretta interna Internal Corner Joint						Sq. Allineamento Alining Corner J.			
	Bottone Slot	Cianfrinare Riveting	Spinare Crimping		Bottone Slot	Cianfrinare Riveting	Spinare Crimping	Avvitare Screw			Esterna External	Interna Internal		
XX70.801					ACX.01.SQ	*ACX.02.SQ	+ARX.07.SQ	+VIL M5x14 D8						ARX.11.SQ
XX70.802					ACX.01.SQ	*ACX.02.SQ	+ARX.07.SQ	+VIL M5x14 D8						
XX70.803					ACX.01.SQ	*ACX.02.SQ	+ARX.07.SQ	+VIL M5x14 D8						
XX70.809					ACX.01.SQ	*ACX.02.SQ	+ARX.07.SQ	+VIL M5x14 D8						ARX.11.SQ

***Per spinatura aggiungere ARX07.SQ | Per avvitatura aggiungere VIL M5x14_D8 [Gruppo C]**
***For crimping add ARX07.SQ | For Screw add VIL M5x14_D8 [Group C]**

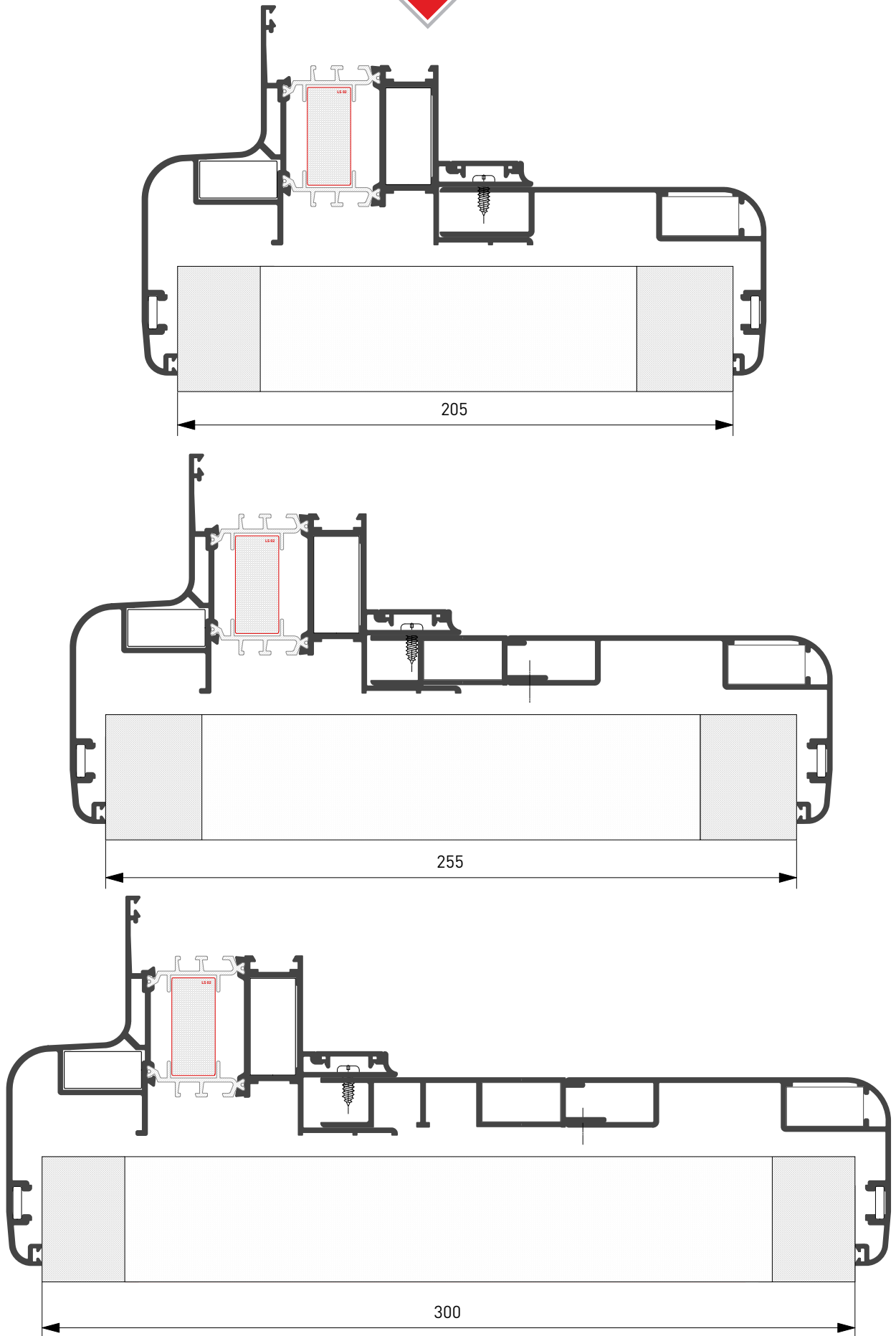

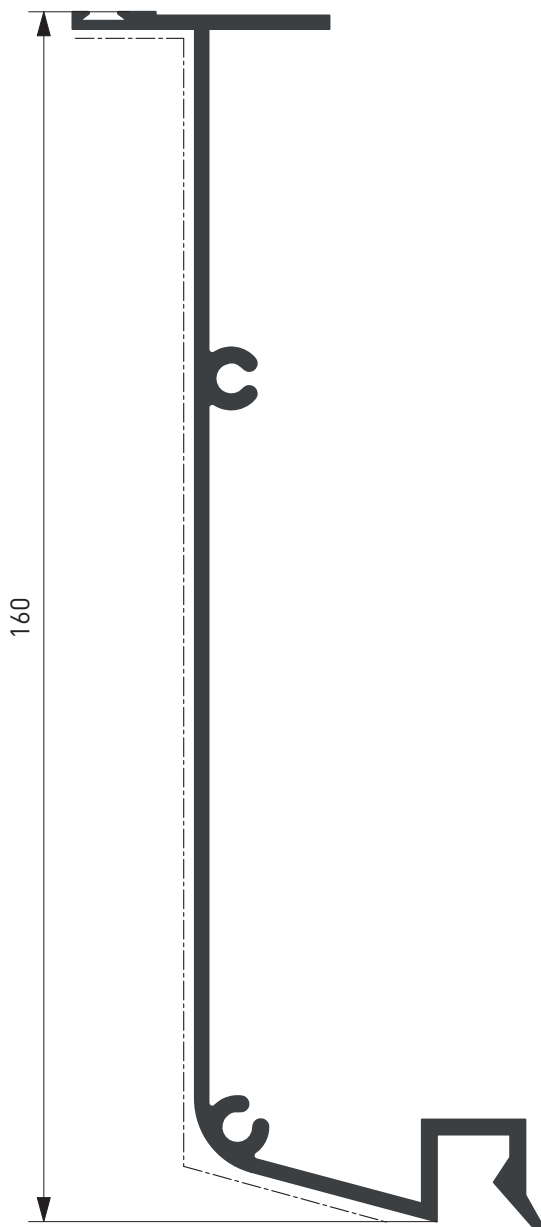

CX45.3363

Kg/ml 1.385
--- mm. 182,0

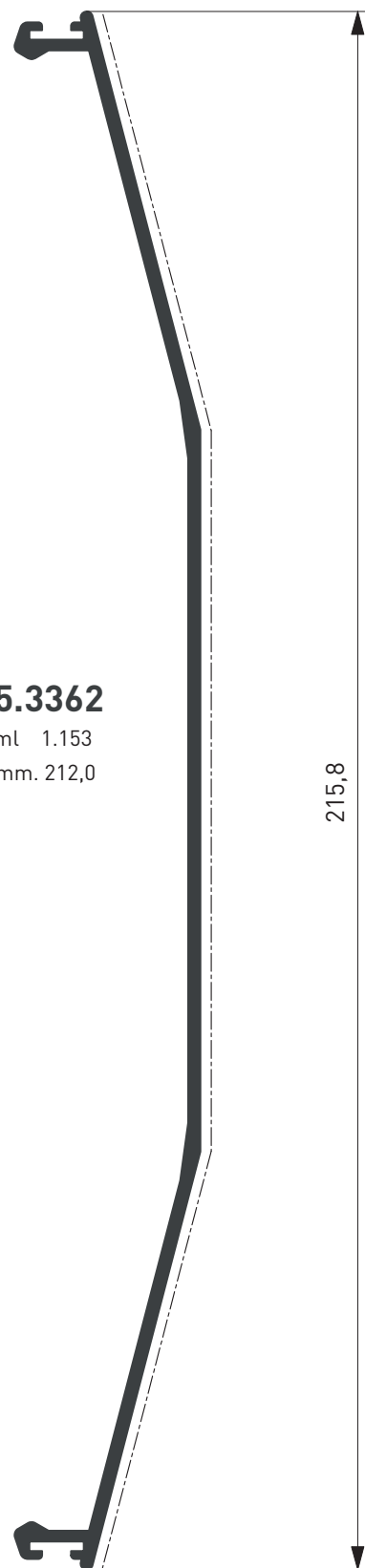

CX45.3362

Kg/ml 1.153
--- mm. 212,0



CX70.540

Kg/ml 0.249
--- mm. 32,0

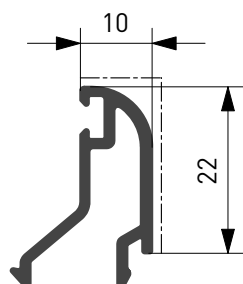

CX70.521

Kg/ml 0.266
--- mm. 36,0

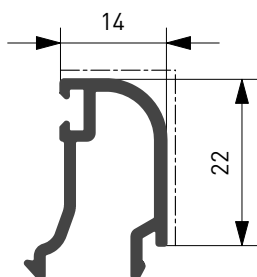

CX70.522

Kg/ml 0.277
--- mm. 40,0

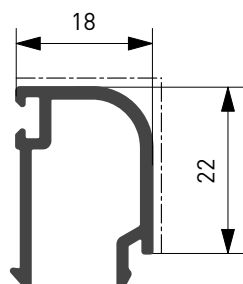

CX70.523

Kg/ml 0.294
--- mm. 44,0

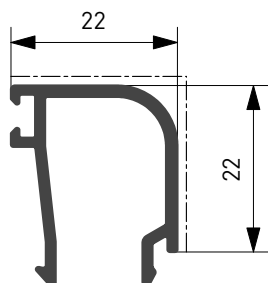

CX70.524

Kg/ml 0.314
--- mm. 48,0

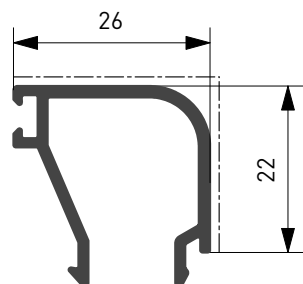

CX70.525

Kg/ml 0.350
--- mm. 52,0

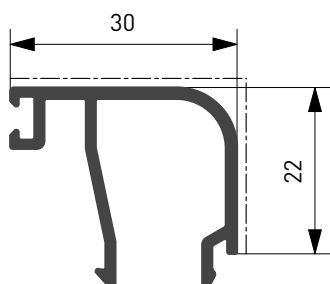

APPLICAZIONE FERMAVETRI TONDI
APPLICATION OF ROUND GLAZING BEADS

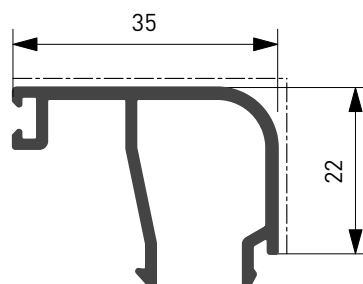
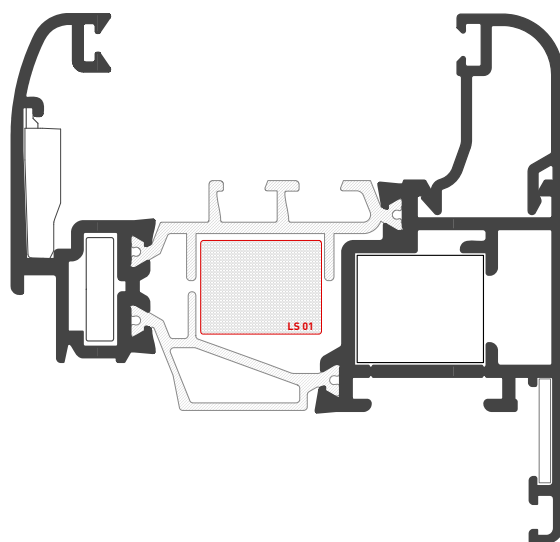

CX70.531

Kg/ml 0.370
--- mm. 57,0



CX70.533

Kg/ml 0.252
--- mm. 27,0

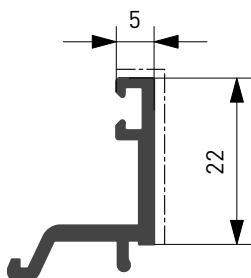

CX70.539

Kg/ml 0.245
--- mm. 27,0

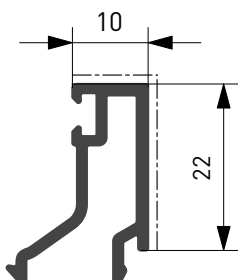

CX70.526

Kg/ml 0.279
--- mm. 36,0

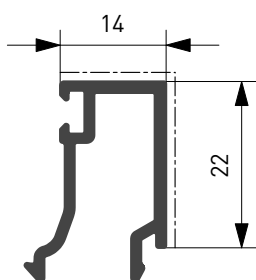

CX70.527

Kg/ml 0.290
--- mm. 40,0

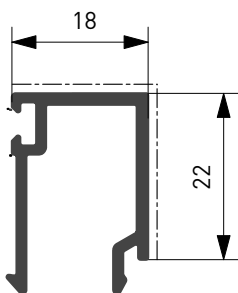

CX70.528

Kg/ml 0.307
--- mm. 44,0

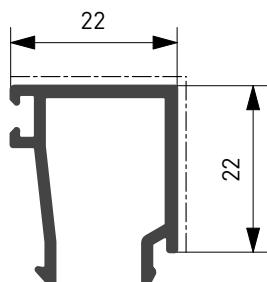

CX70.529

Kg/ml 0.327
--- mm. 48,0

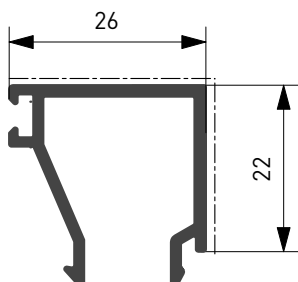

APPLICAZIONE FERMAVETRI DRITTI
APPLICATION OF STRAIGHT GLAZING BEADS

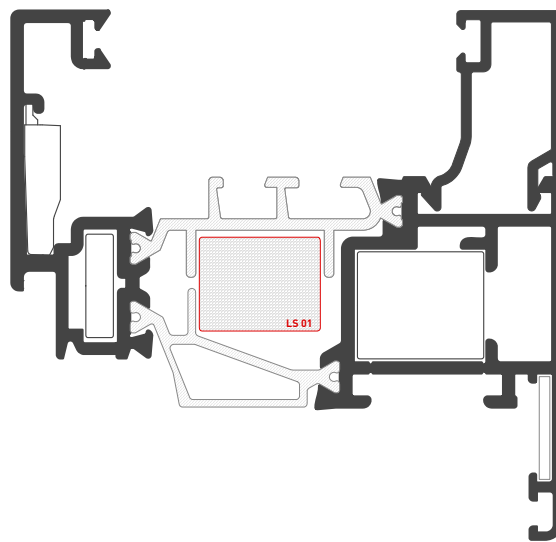

CX70.530

Kg/ml 0.362
--- mm. 52,0

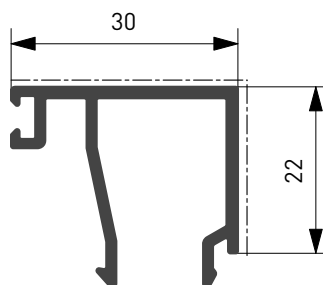

CX70.532

Kg/ml 0.383
--- mm. 57,0

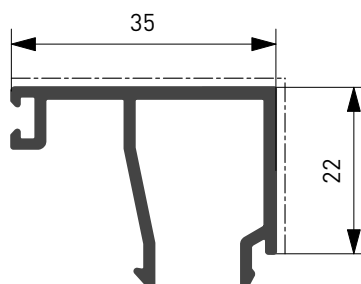

CX70.537

Kg/ml 0.403
--- mm. 62,0

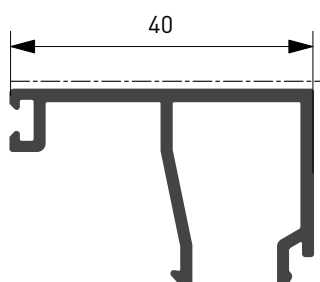



CX70.568

Kg/ml 0.303
--- mm. 32,0

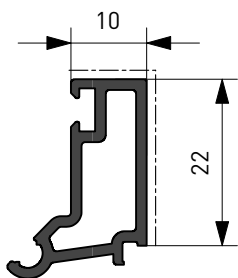

CX70.562

Kg/ml 0.309
--- mm. 36,0

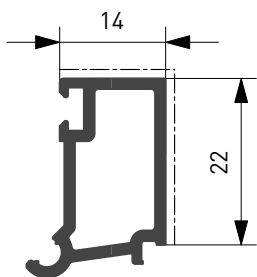

CX70.563

Kg/ml 0.331
--- mm. 40,0

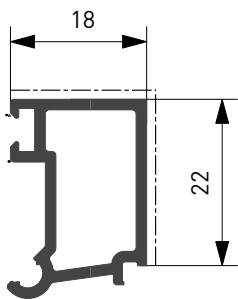

CX70.564

Kg/ml 0.349
--- mm. 44,0

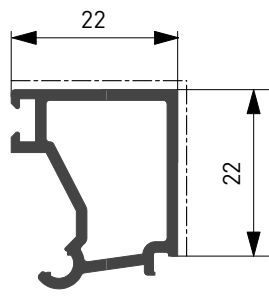

CX70.565

Kg/ml 0.374
--- mm. 48,0

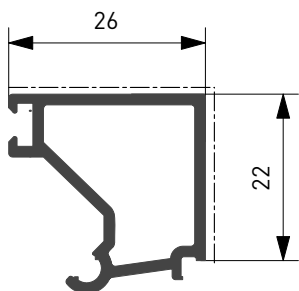

CX70.566

Kg/ml 0.400
--- mm. 52,0

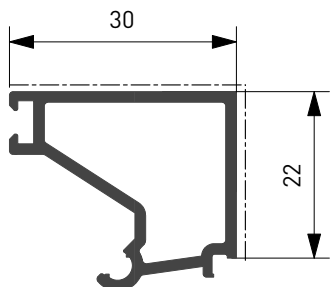

APPLICAZIONE FERMAVETRI DI SICUREZZA
APPLICATION OF STRAIGHT SAFETY GLAZING BEADS



ATTENZIONE | ATTENTION

UTILIZZARE UN PEZZO OGNI
300 mm. (min 2 Pz.)
CONSIDERARE LA
GUARNIZIONE INTERNA A
ZEPPA Min. 4 mm.

- USE ONE PIECE EVERY 300 mm.
- CONSIDER THE INTERNAL WEDGE GASKET Min. 4 mm.

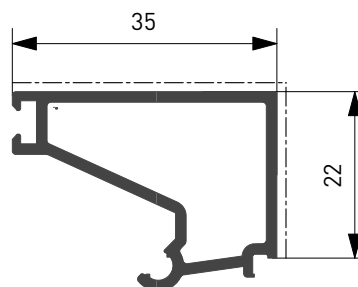
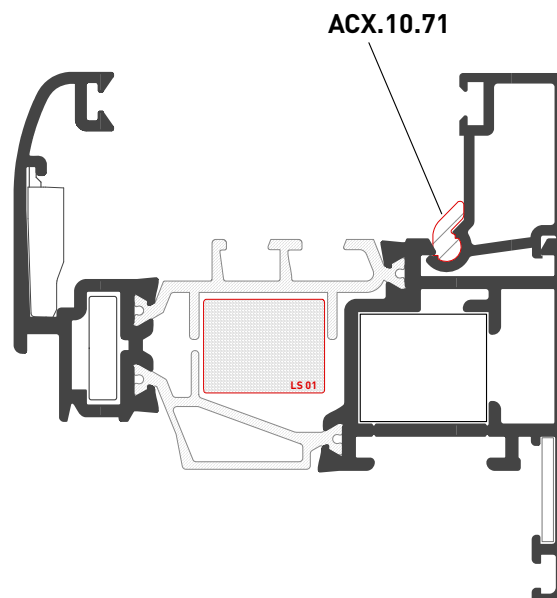

CX70.567

Kg/ml 0.436
--- mm. 57,0



CX70.571

Kg/ml 0.215
--- mm. 36,0

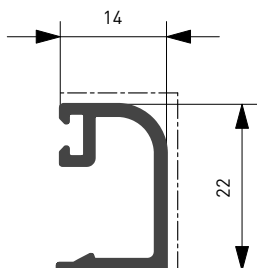

CX70.572

Kg/ml 0.275
--- mm. 40,0

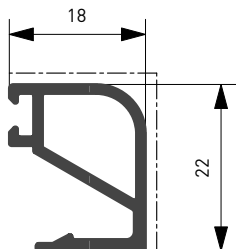

CX70.573

Kg/ml 0.298
--- mm. 44,0

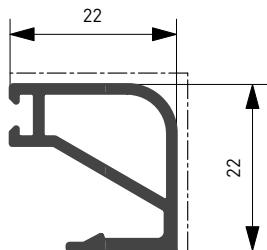

CX70.574

Kg/ml 0.329
--- mm. 48,0

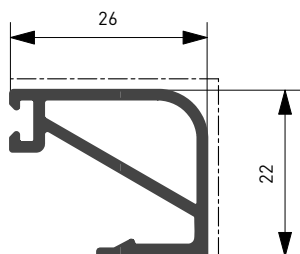

CX70.575

Kg/ml 0.354
--- mm. 52,0

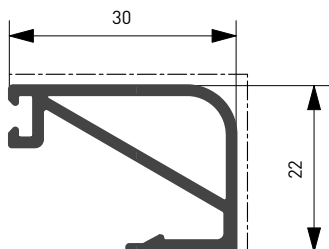

RX70.581

Kg/ml 0.377
--- mm. 57,0

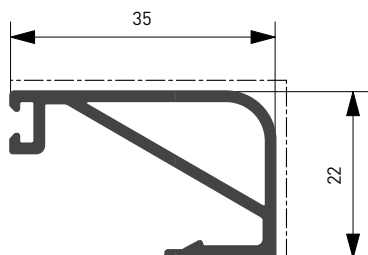

APPLICAZIONE FERMAVETRI C/CLIPS
APPLICATION OF ROUND GLAZING BEADS w/CLIPS

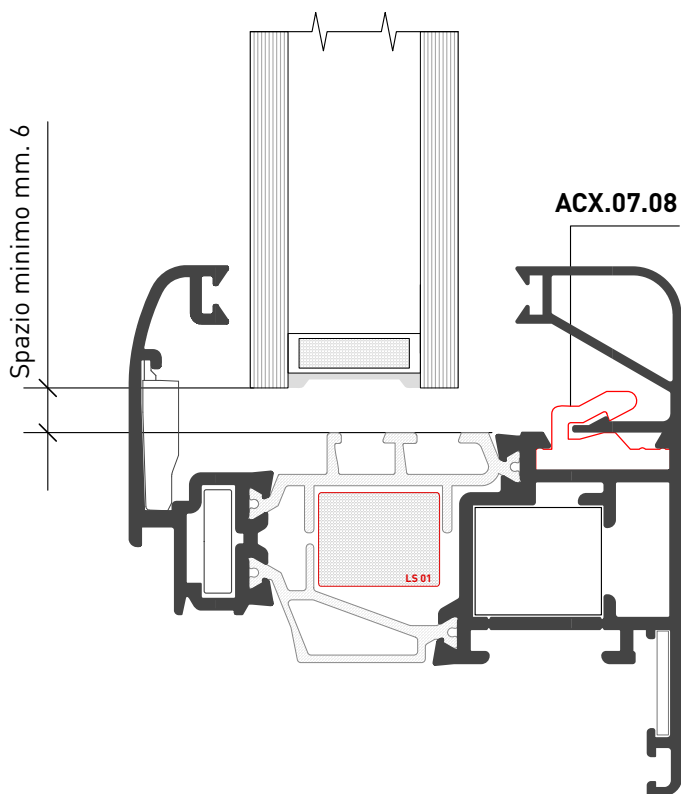

E' consigliabile l'abbinamento con fermavetri tradizionali tondi con taglio a 45°, al fine di evitare gli angoli fermavetro in zama

It is advisable to combine with traditional round glazing beads with a 45° cut, in order to avoid zamac glazing bead corners



Aletta Flap (a) mm.	Vuoto Gap (v) mm.	Dim. Fermavetro Glazing Bead Size (f) mm.	CODICE Fermavetro Glazing Bead CODE		Guarnizione EXT EXT Gasket mm.	Guarnizioni INTERNE Vetro INTERNAL Glass Window Gaskets									
			D	T		ARX.10.15		ARX.10.14		ARX.10.13		ARX.10.12			
			D = dritto T = tondo			mm.10	mm.9	mm.8	mm.7	mm.6	mm.5	mm.4	mm.3		
												Vetrage Glazing			
5	25	35	D	CX70.532	3	12	13	14	15	16	17	18	19		
			T	CX70.531											
5	30	30	D	CX70.530	3	17	18	19	20	21	22	23	24		
			T	CX70.525											
5	34	26	D	CX70.529	3	21	22	23	24	25	26	27	28		
			T	CX70.524											
5	38	22	D	CX70.528	3	25	26	27	28	29	30	31	32		
			T	CX70.523											
5	42	18	D	CX70.527	3	29	30	31	32	33	34	35	36		
			T	CX70.522											
5	46	14	D	CX70.526	3	33	34	35	36	37	38	39	40		
			T	CX70.521											
5	55	5	D	CX70.533	3	42	43	44	45	46	47	48	49		
			T												

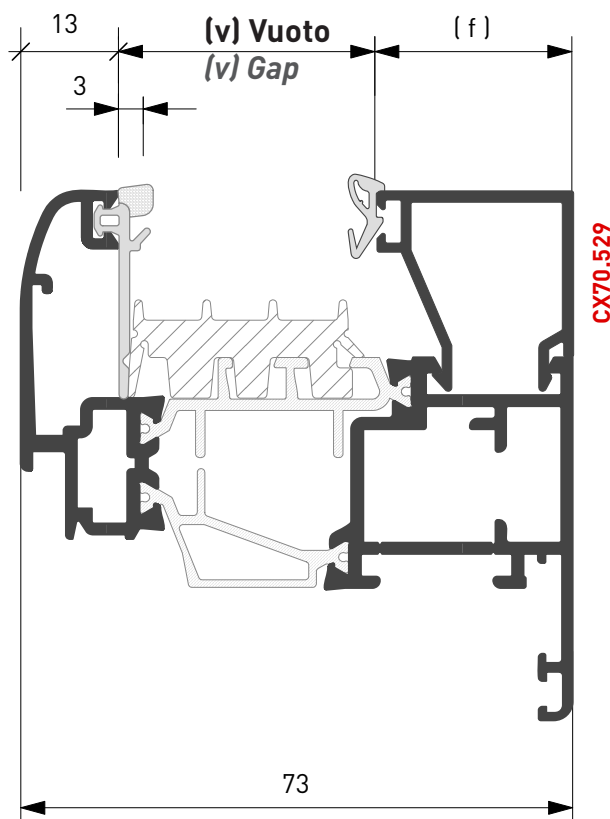
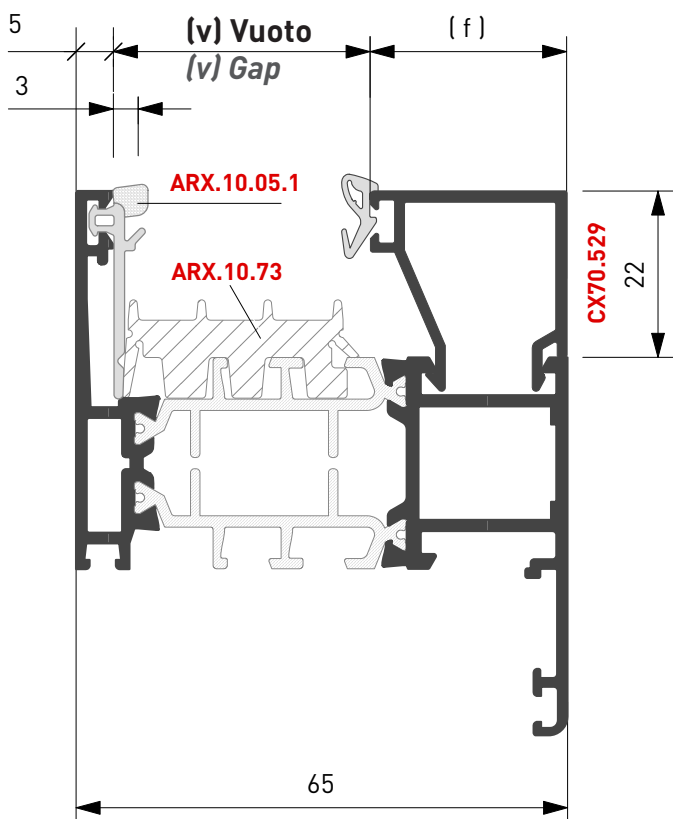



TASSELLI VETRO PER TIPOLOGIA
GLASS DOWELS FOR TYPE

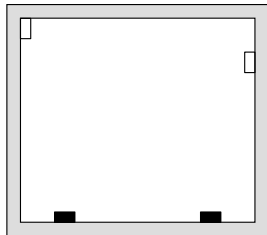

Telaio Fisso
Fixed Frame

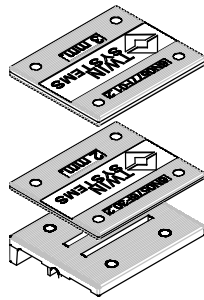

ARX 07.09

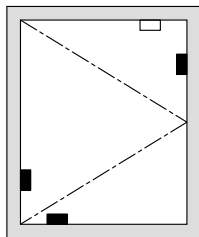

Anta Battente
Casement Window

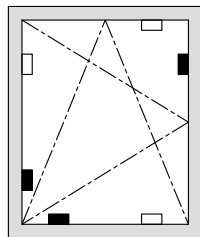

Anta Ribalta
Csement+Protruding Window

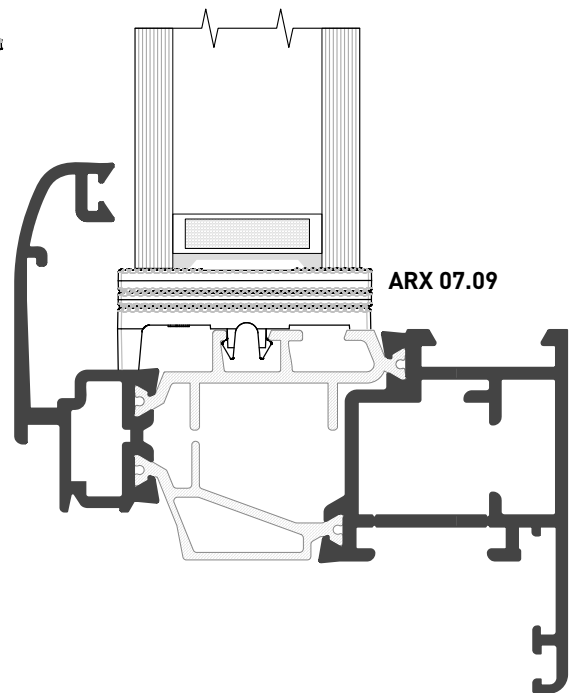

ARX 07.09

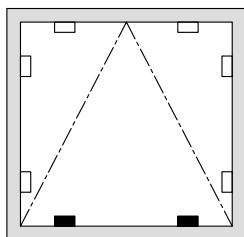

Wasistas
Protruding Window

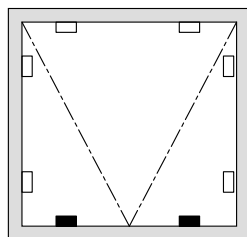

Sporgere
Transom Window

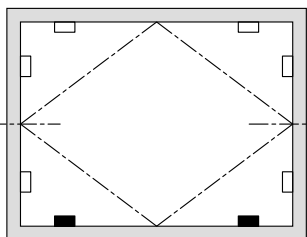

Bilico Orizzontale
Horizontal Pivoting Window

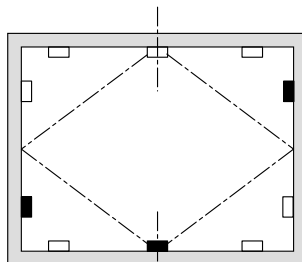

Bilico Verticale
Vertical Pivoting Window

-  **TASSELLO di APPOGGO**
SUPPORTING PLUG
-  **TASSELLO PERIMETRALE**
PERIMETER PLUG



Accessori e Guarnizioni
Accessories and Gaskets

Gruppo C

Elenco accessori | *List of Accessories*
Elenco guarnizioni | *List of Window Gaskets*



CODIFICA FINITURE SUPERFICIALI ACCESSORI ACCESSORIES SURFACE FINISHING CODES

In fase di ordine aggiungere agli accessori, se previste, le seguenti codifiche superficiali:
When ordering, add the following surface codes to the accessories listed below, where applicable:

<i>DESCRIPTION</i>	CODICE CODE	<i>DESCRIZIONE</i>
<i>PAINTED MATT BLACK</i>	NEOPA	VERNICIATO NERO OPACO
<i>WHITE</i>	R 9 0 1 0	VERNICIATO BIANCO
<i>IVORY</i>	R 1 0 1 3	VERNICIATO AVORIO
<i>GREEN</i>	R 6 0 0 5	VERNICIATO VERDE
<i>BLACK</i>	R 9 0 0 5	VERNICIATO NERO LUCIDO
<i>BROWN</i>	R 8 0 1 7	VERNICIATO MARRONE
<i>GOTHIC GREEN</i>	G 6 3 6 0	VERNICIATO VERDE GOTICO
<i>GOTHIC GREY</i>	G 9 4 2 0	VERNICIATO GRIGIO GOTICO
<i>GOTHIC BROWN</i>	G 3 9 7 6	VERNICIATO MARRONE GOTICO
<i>SILVER</i>	V E A R	VERNICIATO ARGENTO
<i>WITHERED MOSS</i>	V S C R A	VERDE SCURO RAGGRINZITO
<i>FALLOW</i>	M A R A G	MARRONE RAGGRINZITO
<i>GOLDFINISH GUNMETAL GRAY</i>	K A N F U	CANNA DI FUCILE GOLDFINISH
<i>GOLDFINISH COPPER</i>	K R A M E	RAME GOLDFINISH
<i>GOLDFINISH POLISHED</i>	K I N O X	INOX LUCIDO GOLDFINISH
<i>GOLDFINISH SATIN-FINISH STAINLESS STEEL</i>	K S A T I	INOX SATINATO GOLDFINISH
<i>GOLDFINISH GOLD</i>	K G O L D	GOLD GOLDFINISH
<i>GOLDFINISH ANTIQUE BRASS</i>	K A N T I C	OTTONE ANTICO GOLDFINISH
<i>NEW SILVER</i>	A R G E N T	NEW ARGENTO
<i>NEW BRONZE</i>	B R O N Z	NEW BRONZO

ESEMPIO

ACX 02.01 | R 9010

EXAMPLE

Cerniera Verniciata | COLORE Bianco Ral 9010
Painted Hinge | COLOUR White RAL 9010



<p>ACX.01.SQ</p> <p>Descrizione <i>Description</i> Squadretta a pulsante <i>Slot Corner Joint</i> (28.5 mm. x 14.5 mm.)</p>		<p>ARX.15.SQ</p> <p>Descrizione <i>Description</i> Squad. allineamento EXT tiraggio meccanico <i>External aligning Corner Joint</i> <i>mechanical draught</i></p>	
<p>ACX.02.SQ</p> <p>Descrizione <i>Description</i> Squadretta cianfrinare/spinare/avvitare <i>Riveting/crimping Corner Joint</i> (28.5 mm. x 14.5 mm.)</p>		<p>ACX.16.SQ</p> <p>Descrizione <i>Description</i> Squadretta a pulsante <i>Slot Corner Joint</i> (17.5 mm. x 15 mm.) Pulsante (Button) 8 mm.</p>	
<p>ARX.03.SQ</p> <p>Descrizione <i>Description</i> Squadretta cianfrinare/spinare <i>Riveting/crimping Corner Joint</i> (4.3 mm. x 14 mm.)</p>		<p>AWX.17.SQ</p> <p>Descrizione <i>Description</i> Squadretta avvitare/cianfrinare/spinare <i>Screwing/Riveting/crimping Corner Joint</i> (17.5 mm. x 35.8 mm.)mm.)</p>	 <p>VIL M5X14_1 Vite per squ Corner Joint</p>
<p>ARX.06.SQ</p> <p>Descrizione <i>Description</i> Squadretta cianfrinare/spinare <i>Riveting/crimping Corner Joint</i> (4.3 mm. x 39.1 mm.)</p>		<p>AWX.19.SQ</p> <p>Descrizione <i>Description</i> Squadretta avvitare/cianfrinare/spinare <i>Screwing/Riveting/crimping Corner Joint</i> (17.5 mm. x 15 mm.)</p>	 <p>VIL M5X14_1 Vite per squ Corner Joint</p>
<p>ARX.07.SQ</p> <p>Spina per ACX.02.SQ e ACX.14.SQ <i>Plug</i></p>		<p>ARX.24.SQ</p> <p>Descrizione <i>Description</i> Squadretta allineamento esterna <i>External Alining Corner Joint</i></p>	
<p>ARX.08.SQ</p> <p>Spina per ACX.03.SQ e ACX.06.SQ <i>Plug</i></p>			
<p>ARX.10.SQ</p> <p>Descrizione <i>Description</i> Squadretta allineamento interna <i>Internal Alining Corner Joint</i></p>		<p>ACX.47.SQ</p> <p>Descrizione <i>Description</i> Cavalotto fermavetri dritti nessuna lavorazione <i>External U-bolt w/straight glazing bead</i> <i>(portata 350 kg.)</i></p>	
<p>ARX.11.SQ</p> <p>Descrizione <i>Description</i> Squadretta allineamento EXT <i>External Alining Corner Joint</i> XX70.801 e RX60.109</p>		<p>ACX.48.SQ</p> <p>Descrizione <i>Description</i> Squadretta angolo variabile <i>Variable Corner Joint</i> (16.8 mm. x 14.3 mm.)</p>	
<p>ARX.13.SQ</p> <p>Descrizione <i>Description</i> Squadretta a pulsante <i>Slot Corner Joint</i> (23.5 mm. x 14.5 mm.)</p>		<p>ARX.58.SQ</p> <p>Descrizione <i>Description</i> Squad. allineam. ante FASCIA <i>T-joint alignment for sash</i> Rientro 13 mm.</p>	 <p>dx - sx L - R</p>
<p>ACX.14.SQ</p> <p>Descrizione <i>Description</i> Squadretta cianfrinare/spinare/avvitare <i>Riveting/crimping Corner Joint</i> (28.5 mm. x 35.8 mm.)</p>		<p>ARX.71.SQ</p> <p>Descrizione <i>Description</i> Squad. allineam. capannoni <i>External alignment corner joint</i> (40 mm. x 3 mm.)</p>	





Cerniere
Hinges

<p>ACX.72.SQ</p> <p>Descrizione <i>Description</i> Squadretta a pulsante <i>Slot Corner Joint</i> (35.9 mm. x 14.7 mm.) Pulsante (Button) 8 mm.</p>		<p>ACX.02.05</p> <p>Descrizione <i>Description</i> Cerniera per vasistas apertura singola 30° <i>Hinge for double opening wasistas window 30°/75°</i></p>	
<p>ACX.73.SQ</p> <p>Descrizione <i>Description</i> Squad. allineam. <i>Alignment corner joint</i> (46. mm. x 1.2 mm.)</p>		<p>ACX.02.06</p> <p>Descrizione <i>Description</i> Cerniera per vasistas apertura doppia 30° e 75° <i>Long arm for wasistas window</i></p>	
<p>VIL M5X14_D8</p> <p>Descrizione <i>Description</i> Vite per squadretta <i>Screw for Corner Joint</i> ACX.02.SQ e ACX.14.SQ AWX.17.SQ e AWX.19.SQ</p>		<p>ACX.02.07</p> <p>Descrizione <i>Description</i> Braccio lungo per vasistas <i>Short arm for wasistas window</i> Anta/Sash= 600/1600 mm.</p>	
<p>ACX.63.SQ</p> <p>Descrizione <i>Description</i> Giunzione a "T" o a "Croce" <i>"T" or "Cross" junction</i> H = 14.4</p>		<p>ACX.02.08</p> <p>Descrizione <i>Description</i> Braccio corto per vasistas Anta/Sash= 280/800 mm.</p>	
<p>ACX.64.SQ</p> <p>Descrizione <i>Description</i> Giunzione a "T" o a "Croce" <i>"T" or "Cross" junction</i> H = 34.8 Pulsante[Button] 8 mm</p>		<p>ACX.02.09</p> <p>Descrizione <i>Description</i> Braccio telescopico per vasistas a scatto <i>Telescopic arm for snap-fit wasistas window</i></p>	
<p>ACX.02.01</p> <p>Descrizione <i>Description</i> Cerniera a montaggio rapido preassemblata a 2 ali <i>Rapid-assembly pre-assembled 2-leafed hinge for 3rd Sash</i></p>		<p>ACX.02.10</p> <p>Descrizione <i>Description</i> Cerniera a compasso <i>Compass Hinge</i></p>	
<p>ACX.02.02</p> <p>Descrizione <i>Description</i> Cerniera a montaggio rapido preassemblata a 3 ali per 3° anta <i>Rapid-assembly pre-assembled 3-leafed hinge</i></p>		<p>ACX.02.10P</p> <p>Descrizione <i>Description</i> Cerniera Scomparsa <i>Concealed Hinge</i> Battente/Casement 40 kg Sporgere/Projection 120 kg Wasistas/Wasistas 120 kg</p>	
<p>ACX.02.03</p> <p>Descrizione <i>Description</i> Cerniera a montaggio rapido preassemblata a 3 ali <i>Rapid-assembly pre-assembled 3-leafed hinge for 3rd Sash</i></p>		<p>ACX.02.11</p> <p>Descrizione <i>Description</i> Cerniera a 2 ali per porte con piastrina ad infilare <i>2-leafed hinge for doors with plate to insert</i></p>	
<p>ACX.02.04</p> <p>Descrizione <i>Description</i> Cerniera a montaggio rapido preassemblata a 3 ali per 3° anta <i>Hinge for single opening wasistas window 30°</i></p>		<p>ARX.02.12</p> <p>Descrizione <i>Description</i> Cerniera per Porta EXT 2 Ali <i>2-leafed hinge for External doors</i> Interasse/Center Dist. = 67 mm.</p>	

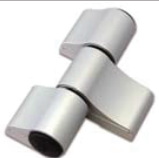



ARX.02.13		
Descrizione	Description	
Cerniera per Porta EXT 3 Ali 3-leafed hinge for External doors Interasse/Center Dist.= 67 mm.		

ARX.02.25		
Descrizione	Description	
Kit gradino Step KIT		

ARX.02.14		
Descrizione	Description	
Cerniera per Porta EXT 2 Ali 2-leafed hinge for External doors Interasse/Center Dist.= 93 mm.		

ARX.02.37		
Descrizione	Description	
Regolatore in altezza Height Adjuster Cerniere/Hinges=ARX.02.11		

ARX.02.15		
Descrizione	Description	
Cerniera per Porta EXT 3 Ali 3-leafed hinge for External doors Interasse/Center Dist.= 93 mm.		

ACX.02.42		
Descrizione	Description	
Cerniera CILINDRIKA Porta INT 2 Ali CILINDRIKA 2-leafed hinge for Internal doors		

ARX.02.16		
Descrizione	Description	
Spessore per Cerniera Porta EXT Spacer for EXT Door Hinge Spessore/Thickness= 8 mm.		

ACX.02.43		
Descrizione	Description	
Cerniera CILINDRIKA Porta INT 3 Ali CILINDRIKA 2-leafed hinge for Internal doors		

ARX.02.17		
Descrizione	Description	
Cerniera per scuretto Hinge for Shutter		

ACX.03.01		
Descrizione	Description	
Cricchetto in alluminio Fissaggio Con Piastrine Plate fixing aluminium ratchet		

ARX.02.21		
Descrizione	Description	
Kit Contropiastrine cerniere 2 Ali 2-leafed hinge strike plates kit		

ARX.03.02		
Descrizione	Description	
Maniglia a Tavellino Tavellino HANDLE		

ARX.02.22		
Descrizione	Description	
Kit Contropiastrine cerniere 3 Ali 3-leafed hinge strike plates kit		

ARX.03.03		
Descrizione	Description	
Maniglia Doppia Double Hinge		

ARX.02.23		
Descrizione	Description	
Perni fissaggio cerniere Hinge Fixing Pins 68 mm.		

ARX.03.04		
Descrizione	Description	
Martellina MARTELLINA Handle Rosette Projection=24 mm.		

ARX.02.24		
Descrizione	Description	
Viti di Fissaggio cerniere Hinge Fixing Screws		

ARX.03.05		
Descrizione	Description	
Martellina con chiave MARTELLINA Handle w/Key Sporg. Quadro/Rosette Projection=24 mm.		



ARX.03.05L	
Descrizione	Description
Martellina LOGICA dx RIGHT MARTELLINA Handle LOGICA	
Sporg. Quadro/Rosette Projection=24 mm.	



ACX.03.15	
Descrizione	Description
Ferma Anta Door Stop	



ARX.03.06	
Descrizione	Description
Cremonese CREMONESE Handle	
Sporg. Quadro/Center Dist. 84/92/104 mm.	



ACX.03.16	
Descrizione	Description
Perno di chiusura supplementare regolabile Supplementary adjustable closing pin	



ARX.03.07	
Descrizione	Description
Cremonese con chiave CREMONESE Handle w/Key	
Interasse/Center Dist.=84/92/104 mm.	



ACX.03.17	
Descrizione	Description
Innesti Cremonese CREMONESE Connections	



ARX.03.07L	
Descrizione	Description
Cremonese LOGICA CREMONESE Handle LOGICA	
Interasse/Center Dist.=84/92/104 mm.	



ACX.03.18	
Descrizione	Description
Terminali astina Bar Terminals	



ARX.03.08	
Descrizione	Description
Cremonese per Anta Ribalta Cremonese for Tilt&Turn Window	
Interasse/	



ACX.03.19	
Descrizione	Description
Sostegno anta Sash Support	



ARX.03.09	
Descrizione	Description
Movimentazione Bidirezionale Bi-directional movement	
Interasse/Center Dist.=15/27 mm.	



ARX.03.22	
Descrizione	Description
Kit Fast Out chiusura apert. EXT Fast Out EXT Open/Close L=1000 mm. (3 punti) (3 points) E=35 mm.	



ACX.03.10	
Descrizione	Description
Movimentazione Unidirezionale per Anta Ribalta Unidirectional movement for Tilt&Turn Window	



ARX.03.23	
Descrizione	Description
Kit Fast Out chiusura apert. EXT Fast Out EXT Open/Close L=600 mm. (2 punti) (2 points) E=35 mm.	



ACX.03.12	
Descrizione	Description
Terminale asta Bar Terminal	



ARX.03.24	
Descrizione	Description
Kit Fast Out chiusura apert. EXT Fast Out EXT Open/Close L=1600 mm. (3 punti) (3 points) E=35 mm.	



ACX.03.14	
Descrizione	Description
Incontro Asta Doppio Double Bar Rest Plate	



ARX.03.28	
Descrizione	Description
Martellina per Fast Out FAST OUT MARTELLINA	
Sporg. Quadro/Rosette Projection=64 mm.	





<p>ARX.03.XX</p> <p>Descrizione <i>Description</i> Kit Fast Out chiusura apert. EXT <i>Fast Out EXT Open/Close</i></p> <p>ARX.03.25 art. ARX.03.22</p> <p>ARX.03.26 art. ARX.03.23</p> <p>ARX.03.27 art. ARX.03.24</p>		<p>ARX.03.50</p> <p>Descrizione <i>Description</i> Cremonese apertura EXT <i>CREMONESE Handle EXT Opening</i></p>	
<p>ACX.03.29</p> <p>Descrizione <i>Description</i> Rostro chiusura supplementare <i>Supplementary closing bolt</i></p>		<p>ACX.03.53</p> <p>Descrizione <i>Description</i> Martellina "ITALIA" cassa 100mm <i>Martellina Handle "ITALIA" case 100mm</i></p>	
<p>ARX.03.30</p> <p>Descrizione <i>Description</i> Tavellino per profilo scuretto <i>Latch for Shutter</i></p>		<p>ACX.03.54</p> <p>Descrizione <i>Description</i> Sirio terminale asta c/Puntale [Ottone] <i>SIRIO Bar Terminal w/Tip [Brass]</i></p> <p>Decentr DX Off Center R \varnothing 8 mm.</p>	
<p>ACX.03.43</p> <p>POLYAMIDE Bar Astina in poliammide</p>		<p>ACX.03.55</p> <p>Descrizione <i>Description</i> Sirio terminale asta c/Puntale [Ottone] <i>SIRIO Bar Terminal w/Tip [Brass]</i></p> <p>Decentr SX Off Center R \varnothing 8 mm.</p>	
<p>ARX.03.45</p> <p>Descrizione <i>Description</i> Perno trascinamento <i>Winding Pivot</i></p> <p>L= 22 mm.</p>		<p>ACX.03.56</p> <p>Descrizione <i>Description</i> Sirio terminale asta c/Puntale [Ottone] <i>SIRIO Bar Terminal w/Tip [Brass]</i></p> <p>\varnothing 8 mm.</p>	
<p>ARX.03.46</p> <p>Descrizione <i>Description</i> Cremonese con chiave <i>CREMONESE Handle w/cylinder Lock</i></p>		<p>ACX.03.57</p> <p>Descrizione <i>Description</i> Cremonese ITALIA <i>CREMONESE Italia Bolt In</i></p> <p>Interasse/Center Dist.=84.5/104 mm.</p>	
<p>ARX.03.47</p> <p>Descrizione <i>Description</i> Perno trascinamento <i>Winding Pivot</i></p> <p>L= 13 mm.</p>		<p>ACX.03.58</p> <p>Descrizione <i>Description</i> ANTIEFFRAZIONE Antibreakage Kit base per Chiusura <i>Closing Accessories Base Kit</i></p>	
<p>ARX.03.48</p> <p>Descrizione <i>Description</i> Cremonese apertura EXT c/chave <i>CREMONESE Handle EXT Op. w/cylinder Lock</i></p>		<p>ACX.03.59</p> <p>Descrizione <i>Description</i> Cremonese ITALIA per AR con anti falsa manovra <i>for AR wrong counter-actuation</i></p>	



<p>ACX.03.60</p> <p>Descrizione <i>Description</i> ANTIEFFRAZIONE <i>Antibreakage</i> Punto chiusura <i>Closure Point</i> Lav Astina Tonda <i>Round Bar Tooling</i> \varnothing 8 mm.</p>		<p>ACX.03.69</p> <p>Descrizione <i>Description</i> Doppia maniglia "ITALIA" <i>Double Handle "ITALIA"</i></p>	
<p>ACX.03.61</p> <p>Descrizione <i>Description</i> ANTIEFFRAZIONE <i>Antibreakage</i> Chiusura Sist. sicurezza connessione Astina <i>Bar Connection Safety System</i></p>		<p>ACX.03.70</p> <p>Descrizione <i>Description</i> Catenaccio a comando diretto <i>Direct drive bolt</i> Sirio</p>	
<p>ACX.03.62</p> <p>Descrizione <i>Description</i> Incontro a pozzetto Puntale <i>Drain Rest Plate Tooling for Tip</i> \varnothing 6 mm.</p>		<p>ACX.03.71</p> <p>Descrizione <i>Description</i> Catenaccio a Leva "Mini tex" <i>"Mini tex" Lever Bolt</i> Sirio</p>	
<p>ACX.03.63</p> <p>Descrizione <i>Description</i> Incontro a pozzetto <i>Drain Rest Plate</i> per puntale \varnothing 6 mm.</p>		<p>ACX.03.72</p> <p>Descrizione <i>Description</i> Movimentazione Bidirezionale <i>Bidirectional Movement</i> Interasse/Center Dist.=23/35 mm.</p>	
<p>ACX.03.64</p> <p>Descrizione <i>Description</i> Corpo di manovra a leva <i>Lever Manoeuvring Body</i> "Mini tex."</p>		<p>ACX.03.73</p> <p>Descrizione <i>Description</i> Martellina ridotta <i>Reduced Martellina handle</i> Sporg Quadrol <i>Rosette Projection</i> 70 mm.</p>	<p>"COMFORT MINI"</p> 
<p>ACX.03.65</p> <p>Descrizione <i>Description</i> Catenaccio a leva Bidirezionale <i>Bidirectional lever bolt</i> "bi-hid" kit</p>		<p>ACX.03.74</p> <p>Descrizione <i>Description</i> Martellina ridotta con cilindro <i>Reduced Martellina handle w/Cylinder</i> Sporg Quadrol <i>Rosette Projection</i> 70 mm.</p>	<p>"COMFORT MINI"</p> 
<p>ACX.03.66</p> <p>Descrizione <i>Description</i> Perno di trascinamento <i>Winding Pivot</i> L=11 mm.</p>		<p>ARX.04.30</p> <p>Descrizione <i>Description</i> Tappo a L battuta inferiore porte <i>L-shaped Plug Bottom Rabbet</i></p>	
<p>ACX.03.67</p> <p>Descrizione <i>Description</i> Perno di trascinamento <i>Winding Pivot</i> L=27 mm.</p>		<p>ARX.04.31</p> <p>Descrizione <i>Description</i> Tappo a L battuta inferiore porte <i>L-shaped Plug Bottom Rabbet</i></p>	
<p>ACX.03.68</p> <p>Descrizione <i>Description</i> Doppia maniglia "Comfort mini" <i>Double Handle "Comfort MINI"</i></p>		<p>ACX.04.51</p> <p>Descrizione <i>Description</i> Ripporto Tondo/Dritto <i>Round/Straight Wing</i> Tappo Ripporto Giunto Aperto <i>Open Coupling Wing Plug</i></p>	

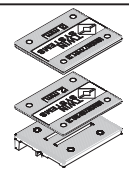

<p>ACX.04.52</p> <p>Descrizione <i>Description</i> Ripporto Tondo/Dritto Round Straight Wing Tappo Riporto Ferramenta Nastro Tape Hardware Wing Plug</p>		<p>ARX.06.02</p> <p>Descrizione <i>Description</i> Piastrina Registro Universale Universal Plate Adjusting Screw</p>	
<p>ACX.04.53</p> <p>Descrizione <i>Description</i> Ripporto Tondo/Dritto Round/Straight Wing Tappo Riporto Doppia Battua Double Gasket Wing Plug</p>		<p>ARX.06.03</p> <p>Descrizione <i>Description</i> Grano per registro Adjusting Grub Screw</p>	
<p>ARX.04.60</p> <p>Descrizione <i>Description</i> Tappo per XX70.643 Porta Spazzolino ANTA Plug for XX70.643 Sash Brush Holder</p>		<p>ACX.06.04</p> <p>Descrizione <i>Description</i> Registro Z/P Z/P Adjusting screw</p>	
<p>ARX.04.69B</p> <p>Descrizione <i>Description</i> Tappo profilo scivolo BIANCO WHITE Plug for slide profile</p>		<p>ARX.06.XX</p> <p>Descrizione <i>Description</i> Grano per registro Adjusting Grub Screw</p>	<ul style="list-style-type: none"> • ARX.06.08 L=15 mm. • ARX.06.09 L=20 mm. • ARX.06.10 L=30 mm. • ARX.06.11 L=45 mm. 
<p>ARX.04.69G</p> <p>Descrizione <i>Description</i> Tappo profilo scivolo GRIGIO GREY Plug for slide profile</p>		<p>ARX.06.13</p> <p>Descrizione <i>Description</i> Registro TWIN Autobloccante su profili alluminio TWIN Adjusting screw Self-locking on aluminium profiles</p>	
<p>ARX.04.69N</p> <p>Descrizione <i>Description</i> Tappo profilo scivolo NERO BLACK Plug for slide profile</p>		<p>ACX.06.14/15</p> <p>Descrizione <i>Description</i> Registro TWIN Autobloccante su Barrette di Poliammide TWIN Adjusting screw Self-locking on Polyamide Bars</p>	<p>ACX.06.14 foro/hole D=7mm</p> <p>ACX.06.15 foro/hole D=9mm</p> 
<p>ARX.04.70</p> <p>Descrizione <i>Description</i> Tappo Gocciolatorio Profilo XX70.2040 Dropper Plug for XX70.2040</p>		<p>ACX.06.16</p> <p>Descrizione <i>Description</i> Rondella di fissaggio per ARX06.14/15 TWIN Fixing Washer for ACX.06.14/15</p>	
<p>ARX.05.01</p> <p>Descrizione <i>Description</i> Pluggetta drenaggio acqua Water Drainage Plug</p>		<p>ACX.07.02</p> <p>Descrizione <i>Description</i> Angolo Universale Fermavetro Universal Corner Glazing Bead</p>	
<p>ARX.06.01</p> <p>Descrizione <i>Description</i> Registro Universale Universal Adjusting Spacer Screw</p>		<p>ARX.07.09</p> <p>Descrizione <i>Description</i> Supporto vetro Universale Glass support kit Spessore Width = 2/3mm</p>	



ACX.08.01	
Descrizione	Description
ANTA RIBALTA WEEN TILT&TURN SASH	
c/anti falsa manovra sulla Cremonese w/ wrong counter-actuation on the Cremonese bolt	
KIT BASE BASE KIT Portata/Plugacity 160 Kg.	



ACX.08.16	
Descrizione	Description
Perno chiusura supplementare Pin additional lock	



ACX.08.18	
Descrizione	Description
Chiusura supplementare inferiore orizzontale Horizontal bottom additional closure	



ACX.08.01L	
Descrizione	Description
ANTA RIBALTA WEEN TILT&TURN SASH	Logica
c/anti falsa manovra sulla Cremonese w/ wrong counter-actuation on the Cremonese bolt	
KIT BASE BASE KIT Portata/Plugacity 160 Kg.	



ACX.08.19	
Descrizione	Description
Microventilazione regolabile Adjustable micro-ventilation	



ACX.08.22	
Descrizione	Description
Anta Ribalta Braccio Corto Tilt&Turn short arm	
L=395 mm. → 450 mm.	



ACX.08.05	
Descrizione	Description
A.R. Braccio Supplementare A.R. Supplementary Arm	



ACX.08.22L	
Descrizione	Description
Anta Ribalta Braccio Corto Tilt&Turn short arm	
L=395 mm. → 450 mm.	



ACX.08.05L	
Descrizione	Description
A.R. Braccio Supplementare A.R. Supplementary Arm	Logica



ACX.08.23	
Descrizione	Description
Anta Ribalta Braccio Medio Tilt&Turn medium arm	
L=451 mm. → 650 mm.	



ACX.08.06	
Descrizione	Description
Chiusura Supplementare Verticale e Universale Supplementary Universal Vertical Closure	

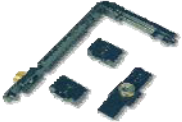

ACX.08.23L	
Descrizione	Description
Anta Ribalta Braccio Medio Drop down door medium arm	
L=451 mm. → 650 mm.	



ACX.08.09	
Descrizione	Description
A.R. Cerniere a Pettine 2.0 A.R. Comb Hinge 2.0	



ACX.08.24	
Descrizione	Description
Anta Ribalta Braccio Lungo Tilt&Turn long arm	
L=650 mm. → 1700 mm.	



ACX.08.13	
Descrizione	Description
Incontro asta singolo Single bar Rest Plate	



ACX.08.24L	
Descrizione	Description
Anta Ribalta Braccio Lungo Tilt&Turn long arm	
L=650 mm. → 1700 mm.	







ACX.08.26	
Descrizione Cerniere vasistas a scomparsa <i>Wasistas concealed hinges</i>	

ACX.08.36	
Descrizione DX Right Ween hide 180	

ACX.08.27	
Descrizione Corto DX <i>SHORT Right</i>	Ween hide 180 Braccio AR a scomparsa <i>Retractable short arm AR</i>
Braccio AR a scomparsa <i>Retractable short arm AR</i>	

ACX.08.37	
Descrizione SX Left Ween hide 180	

ACX.08.28	
Descrizione Corto SX <i>SHORT Left</i>	<i>Description</i>

ACX.08.38	
Descrizione DX Right	 Ween hide 180 Cerniera Sup. Scomparsa <i>Top Retractable Hinge</i>
DX Right	

ACX.08.29	
Descrizione Corto DX <i>SHORT Right</i>	Logica

ACX.08.39	
Descrizione SX Left	 Ween hide 180 Cerniera Sup. Scomparsa <i>Top Retractable Hinge</i>
SX Left	

ACX.08.30	
Descrizione Corto SX <i>SHORT Left</i>	Logica

ACX.08.40	
Descrizione Rinvio d'angolo, terminali e riscontri in zama <i>Corner return, terminals and handles in zamak.</i>	Ween hide 180 KIT BASE c/Anti Falsa Manovra su CREMONESE <i>BASE KIT w/wrong counter-actuation on CREMONESE Bolt</i>
Logica	

ACX.08.31	
Descrizione Medio DX <i>Medium Right</i>	
Medio DX <i>Medium Right</i>	

ACX.08.41	
Logica	

ACX.08.32	
Descrizione Medio SX <i>Medium Left</i>	

ACX.08.42	
Descrizione c/scatto microventilazione <i>w/Microventilation Trigger</i>	 Martellina ITALIA

ACX.08.33	
Descrizione Medio DX <i>Medium Right</i>	Logica









ACX.08.43	
Descrizione Anta Ribalta Automatica <i>Automatic Tilt & Turn Sash</i>	 Ween Wi-Cloud ar
Max load 160 Kg.	

ACX.08.34	
Descrizione Medio SX <i>Medium Left</i>	Logica

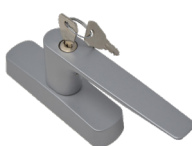
ACX.08.35	
Descrizione Supporto Anta <i>Sash Support</i>	 Ween hide 180
Max load 170 Kg.	

ACX.08.44	
Descrizione Catenaccio a leva ad appoggio <i>Lever Bolt</i>	 Per anta affiancata WEEN <i>For WEEN Side-by-Side Sash</i>
Sporg. Quadro Rosette Projection 24 mm.	

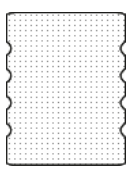

<p>ACX.08.48</p> <p>Descrizione <i>Description</i> Kit cerniere ribalta anta affiancata "ween" <i>Hinge kit with Tilt&Turn addit. sash "</i> Portata/Max Load 160 Kg.</p>		<p>ACX.08.83</p> <p>Descrizione <i>Description</i> Cremonese "KARMA" <i>Cremonese handle</i> Interasse/Center Dist.=84.5/104 mm.</p>	
<p>ACX.08.49</p> <p>Descrizione <i>Description</i> Chiusura supplementare laterale con riscontro regolabile <i>Add closing w/adjustable counterplate</i></p>	<p>Per anta Ribalta WEEN For WEEN T&T Sash</p> 	<p>ACX.08.84</p> <p>Descrizione <i>Description</i> Cremonese "KARMA" con chiave <i>Cremonese handle with Key</i> Interasse/Center Dist.=84.5/104 mm.</p>	
<p>ACX.08.50</p> <p>Descrizione <i>Description</i> "SHARK" Kit di fissaggio martellina minimal - art. ACX08.52 <i>Kit de fixation de poignee minimal with ACX08.52</i></p>		<p>ACX.08.85</p> <p>Descrizione <i>Description</i> Cremonese "KARMA" anta ribalta con chiave <i>Cremonese handle Tilt-Turn with key</i> Interasse/Center Dist.=84.5/104 mm.</p>	
<p>ACX.08.52</p> <p>Descrizione "TWIN" martellina minimale da abbinare con ACX.08.50 <i>"TWIN" Martellina minimal handle combine with ACX.08.50</i></p>		<p>ACX.04.63</p> <p>Descrizione <i>Description</i> Clip per profili XX70.503-504 <i>Profile clip XX70.503-504</i></p>	
<p>ACX.08.60</p> <p>Descrizione <i>Description</i> Martellina <i>Martellina HANDLE</i> Sporg. Quadro/Rosette Projection=24 mm.</p>		<p>LS LISTELLO ISOLANTE <i>INSULATING STRIP</i></p> <ul style="list-style-type: none"> • LS 01 11x15 mm. • LS 02 35x15 mm. • LS 03 18x15 mm. • LS 04 45x15 mm. • LS 05 95x15 mm. • LS 23 30x25 mm. • LS 24 57x5 mm. • LS 27 39x5 mm. • LS 36 56x15 mm. • LS 46 30x25 mm. 	













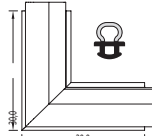

MOTORIZZAZIONE FINESTRE

Motorization windows

<p>ACX.20.05</p> <p>Descrizione <i>Description</i> Attuatore a catena a scomparsa <i>Concealed chain actuator</i></p>		<p>ACX.20.08</p> <p>Descrizione <i>Description</i> Sensore pioggia riscaldato <i>Heated rain sensor</i></p>	
<p>ACX.20.06</p> <p>Descrizione <i>Description</i> Serratura elettromeccanica <i>Electomechanical lock</i></p>		<p>ACX.20.09</p> <p>Descrizione <i>Description</i> Braccio limitatore per vasistas <i>Restrictor arm for hung opening</i></p>	
<p>ACX.20.07</p> <p>Descrizione <i>Description</i> Kit base anta ribalta automatica (con attuatore ed elettro-serratura) <i>Base kit for automatic tilt-turn (with actuator and electomechanical lock)</i></p>			

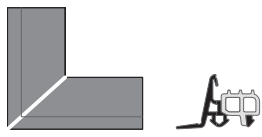

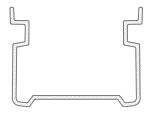
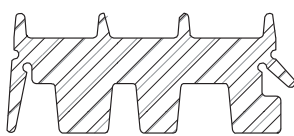
GUARNIZIONI | GASKETS

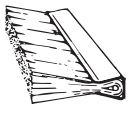
<p>ACX.10.03</p> <p>Descrizione <i>Description</i> Guarnizione di battuta a scatto <i>Snap-On Rabbet window gasket</i></p>		<p>ARX.10.27</p> <p>Descrizione <i>Description</i> Rotella infilata guarnizioni <i>Window gasket threader</i></p>		
<p>ACX.10.04</p> <p>Descrizione <i>Description</i> Guarnizione di battuta ad infilo <i>Rabbet window gasket to insert</i></p>		<p>ARX.10.XX</p> <p>Descrizione <i>Description</i> Guarnizione Vetro INT <i>Glass Window Gasket INT</i></p>	<p>ARX.10.12 Spessore Width 3 - 4 mm.</p> 	
<p>ACX.10.04.1</p> <p>Descrizione <i>Description</i> Guarnizione di battuta ad infilo 3.5mm <i>Rabbet window gasket to insert</i></p>			<p>ARX.10.13 Spessore Width 5 - 6 mm.</p> 	
<p>ACX.10.04.2</p> <p>Descrizione <i>Description</i> Angolo per Guarnizione di battuta ad infilo ACX.10.04.01 <i>Corner for rabbet window gasket to insert ACX.10.04.01</i></p> 			<p>ASX.10.35</p> <p>Descrizione <i>Description</i> Guarnizione rigida per porte <i>Rigid window gasket for doors</i></p> 	
<p>ARX.10.05.1</p> <p>Descrizione <i>Description</i> Guarnizione vetro esterna coestrusa per isolamento termico-acustico <i>Coextruded external glass gasket for thermal-acoustic insulation</i></p> 			<p>ARX.10.61</p> <p>Descrizione <i>Description</i> Guarnizione centrale di Precamera <i>Pre-chamber Central window gasket</i></p> 	
<p>ARX.10.07</p> <p>Descrizione <i>Description</i> Guarnizione di battuta acustica <i>EXT glass acoustic window gasket</i></p> 		<p>ARX.10.62</p> <p>Descrizione <i>Description</i> Angolo per Guarnizione centrale di Precamera ARX.10.61 <i>Corner for Pre-chamber Central window gasket</i></p> 		
<p>ARX.10.08</p> <p>Descrizione <i>Description</i> Guarnizione di battuta <i>Rabbet window gasket</i></p> <p>FERRAMENTA A NASTRO TAPE HARDWARE</p> 		<p>ACX.10.71</p> <p>Descrizione <i>Description</i> Guarnizioni fermavetro di sicurezza (a pezzi) <i>Item for safety glazing bead (in pieces)</i></p> 		
<p>ARX.10.09</p> <p>Descrizione <i>Description</i> Canalina isolante per ferramenta a nastro <i>Insulating channel for hardware tape-type</i></p> 		<p>ARX.10.73</p> <p>Descrizione <i>Description</i> Guarnizione sotto vetro <i>Gasket under glass</i></p> 		
<p>ARX.10.10</p> <p>Descrizione <i>Description</i> Spazzola a pavimento con supporto <i>Window door seal brush w/holder</i></p> 		<p>ARX.10.83</p> <p>Descrizione <i>Description</i> Spazzola a pavimento H 15 mm <i>Window door seal brush H. 15 mm.</i></p> 		



GUARNIZIONI | GASKETS

ACX.10.97	
Descrizione	Description
Guarnizione profilo dogia	
<i>Gasket for stave profile</i>	

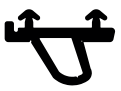
ACX.10.98	
Descrizione	Description
Guarnizione profilo XX70.643 per porte	
<i>Gasket for profile XX70.643 for doors</i>	



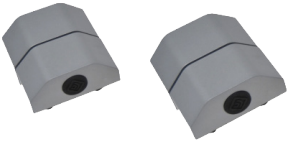

ACCESSORI BILICO

Vertical PIVOT

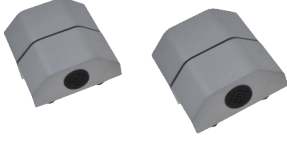
ARX.03.75	
<p>Descrizione <i>Description</i></p> <p>Coppia cerniere a frizione con blocco <i>Couple of friction hinges for pivoty window without lock</i></p>	

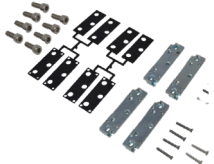
ARX.03.76	
<p>Descrizione <i>Description</i></p> <p>Coppia cerniere a frizione senza blocco <i>Couple of friction hinges for pivoty window without lock</i></p>	

ACX.03.77	
<p>Descrizione <i>Description</i></p> <p>Guarnizione di battuta a scatto <i>Snap-On Rabbet window gasket</i></p>	

ACX.03.78	
<p>Descrizione <i>Description</i></p> <p>Kit chiusura perimetrale base bilico CX <i>Multi-point locking kit for pivot window CX groove</i></p>	

ACX.03.79	
<p>Descrizione <i>Description</i></p> <p>Kit chiusura perimetrale supplementare bilico CX <i>Multi-point locking kit for pivot window CX groove</i></p>	

ACX.03.80	
<p>Descrizione <i>Description</i></p> <p>Riscontro per chiusure supplementari <i>Adjustable striker for additional closing CX</i></p>	

ACX.03.81	
<p>Descrizione <i>Description</i></p> <p>Chiusura supplementare perno eccentrico <i>Supplementary locking eccentric pin</i></p>	

ARX.03.04	
<p>Descrizione <i>Description</i></p> <p>Martellina <i>Martellina HANDLE</i> Sporg. Quadro/Rosette Projection=26 mm.</p>	

ACX.08.42	
<p>Descrizione <i>Description</i></p> <p>c/scatto microventilazione <i>w/Microventilation Trigger</i></p> <p style="text-align: right;">Martellina ITALIA</p>	

ACX.08.60	
<p>Descrizione <i>Description</i></p> <p>Martellina <i>Martellina HANDLE</i> Sporg. Quadro/Rosette Projection=24 mm.</p>	

Bilico VERTICALE

Vertical PIVOT

ACX.03.08	
<p>Descrizione <i>Description</i></p> <p>Cremonese "COMFORT" <i>Cremonese handle</i> interasse/Center Distance 84.5/104</p>	

ACX.03.59	
<p>Descrizione <i>Description</i></p> <p>Cremonese "ITALIA" <i>Cremonese handle</i> interasse/Center Distance 84.5/104</p>	

ACX.03.10	
<p>Descrizione <i>Description</i></p> <p>Bloccetto collegamento unidirezionale <i>Connecting block one-way</i></p>	

ACX.03.82	
<p>Descrizione <i>Description</i></p> <p>Bloccetto collegamento <i>Connecting block</i></p>	

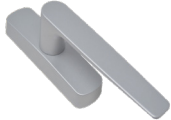
ACX.08.83	
<p>Descrizione <i>Description</i></p> <p>Cremonese "KARMA" <i>Cremonese handle</i></p>	

Bilico ORIZZONTALE

Horizontal PIVOT

ARX.03.94	
<p>Descrizione <i>Description</i></p> <p>Bloccetto collegamento <i>Connecting block</i></p>	

ARX.03.45	
<p>Descrizione <i>Description</i></p> <p>Perno trascinamento <i>Winding Pivot</i> L= 22 mm.</p>	

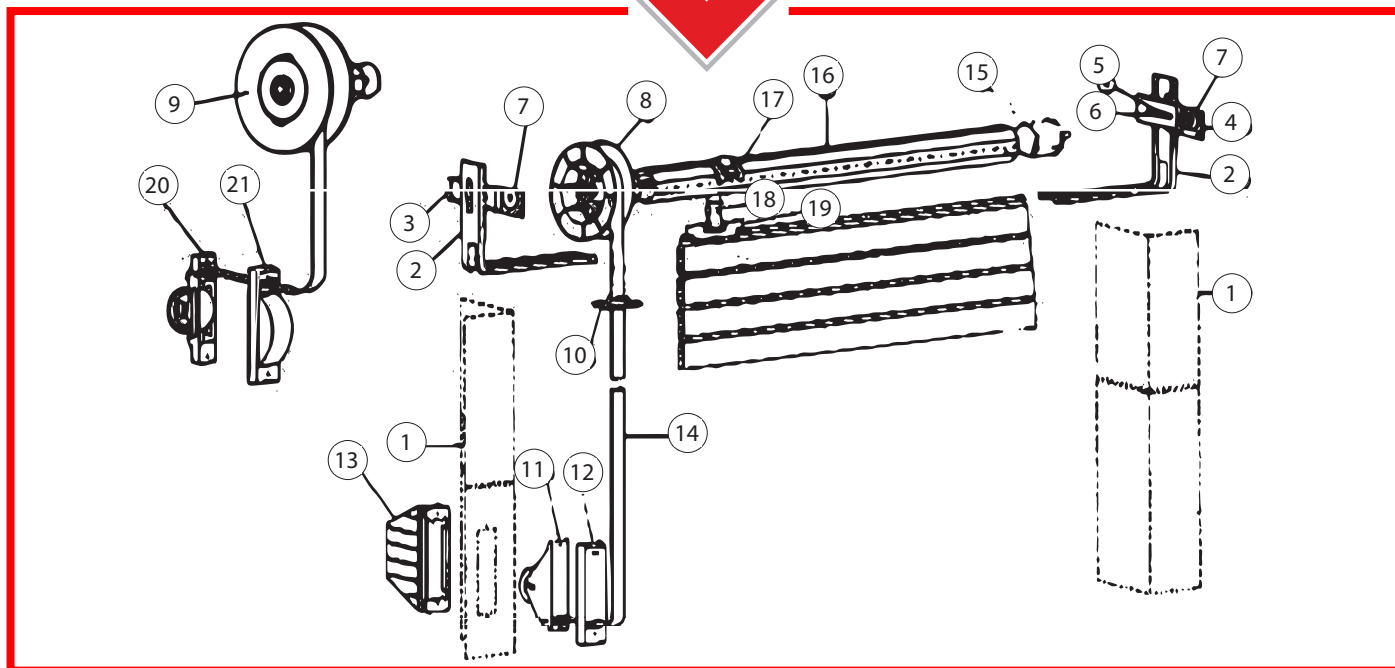

MONOBLOCCO - Soluzione Puleggia | Monobloc - Solution with pulley

Art./Item	Descrizione Description	Dim (mm.)	Rif. Ref.	Scelta Choice	Rif. Ref.
ARX.11.01	Supporto a squadra Square support	A = 46	2		2
ARX.11.02	Mensola per Supporto(SX) Support Shelf (Left)		1		3
ARX.11.03	Mensola per Supporto(DX) Support Shelf (Right)		1		4
ARX.11.04	Vite 6x20 c/dado Screw W/Nut		2		5-6
ARX.11.05	Boccola in Nylon Nylon Bushing		2		7
ARX.11.06	Puleggia in Plastica a Minimo Ingombro Small Sized Plastic Pulley	Ø 220	1	Tipo Type	8
ARX.11.07	Guida Cinghia Trasversale in Nylon Nylon cross strap guide		1	Colore Colour	10
ARX.11.08	Avvolgitore Rewinder		1		11
ARX.11.09	Placca Plaque		1	Tipo Type	12
ARX.11.10	Cassetta Cassette		1	Tipo Type	13
ARX.11.11	Cintolino Tape		Mt.	Tipo Type	14
ARX.11.12	Calotta in Plastica Plastic Plug		1		15
ARX.11.13	Rullo Ottagonale Octagonal Roller		Mt.	Tipo Type	16
ARX.11.14	Gancio Attacco Cintino/Rullo Hook for attaching the tape to the roller		2		17
ARX.11.15	Grappa Fermacintino Tape Locking Clip		2		18
ARX.11.16	Gancio per Avvolgibile in Plastica c/Asola Plastic Roller Hook w/Slot		2		19

MONOBLOCCO - Soluzione Puleggia | Monobloc - Solution with pulley

ARX.11.18	Riduttore portata 40 kg. Load reducer 40 kg	R=1;2.6	1		9
	Puleggia Pulley	Ø 220	1		
ARX.11.19	Avvolgitore Rewinder		1		20
ARX.11.20	Placca Plaque		1	Tipo Type	21

Vari | Miscellaneous

ARX.11.21	Invito Tapparella [Nylon su Profilo Alluminio] Shutter Guide [Nylon on Aluminium Profile]				
ARX.11.22	Coppia Tappi Laterali Cassonetto in Alluminio Pair of side Plugs for aluminium shutter box				
ARX.11.23	Supporto a squadra Square support A = mm 46.				



Nodi
Main Sections

Gruppo D

Sezioni principali
e Accessori
Sc. 1:1

Main Sections and
Accessories
Scale 1:1



SCHEMA DIMENSIONALE
DIMENSIONAL DIAGRAM

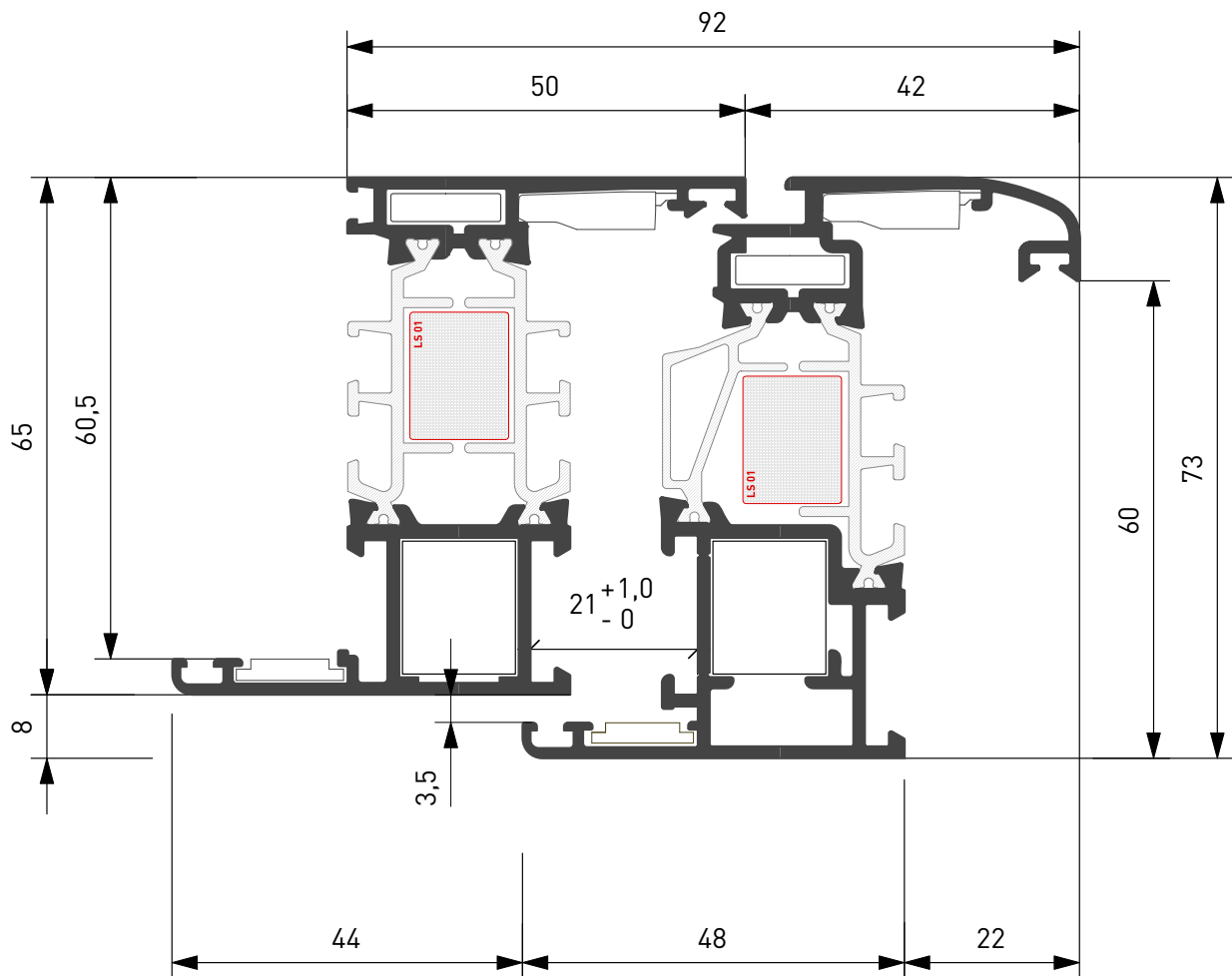



FINESTRA A 2 ANTE
DOUBLE SASH WINDOW

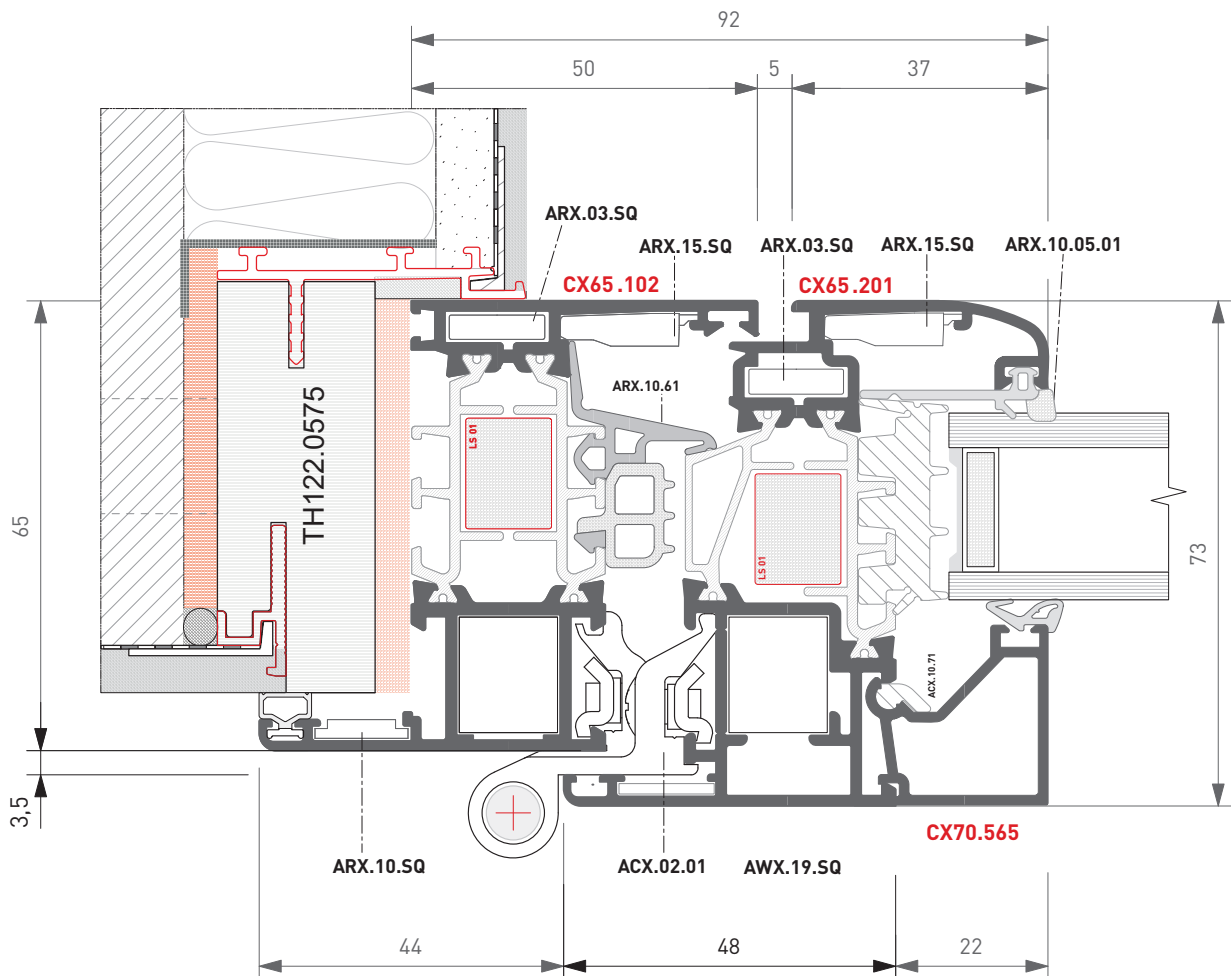
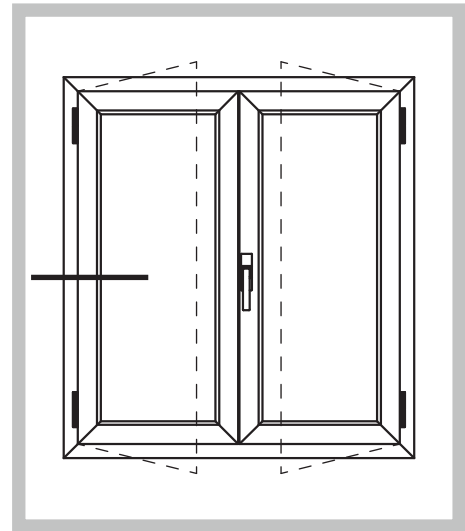



FINESTRA A 2 ANTE
DOUBLE SASH WINDOW

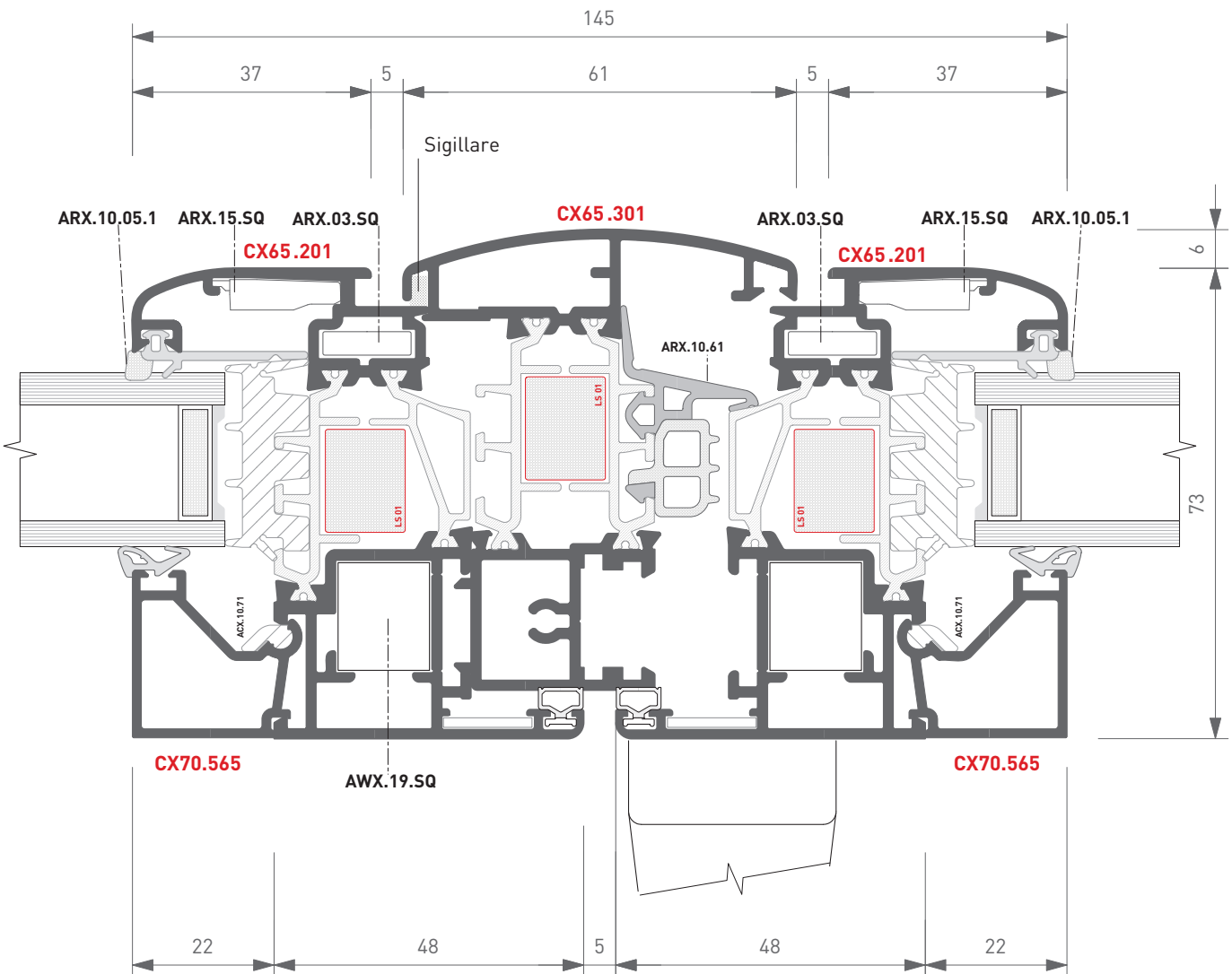
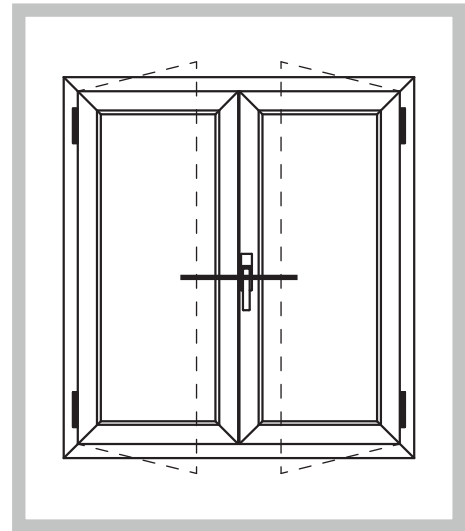



FINESTRA A 2 ANTE
DOUBLE SASH WINDOW

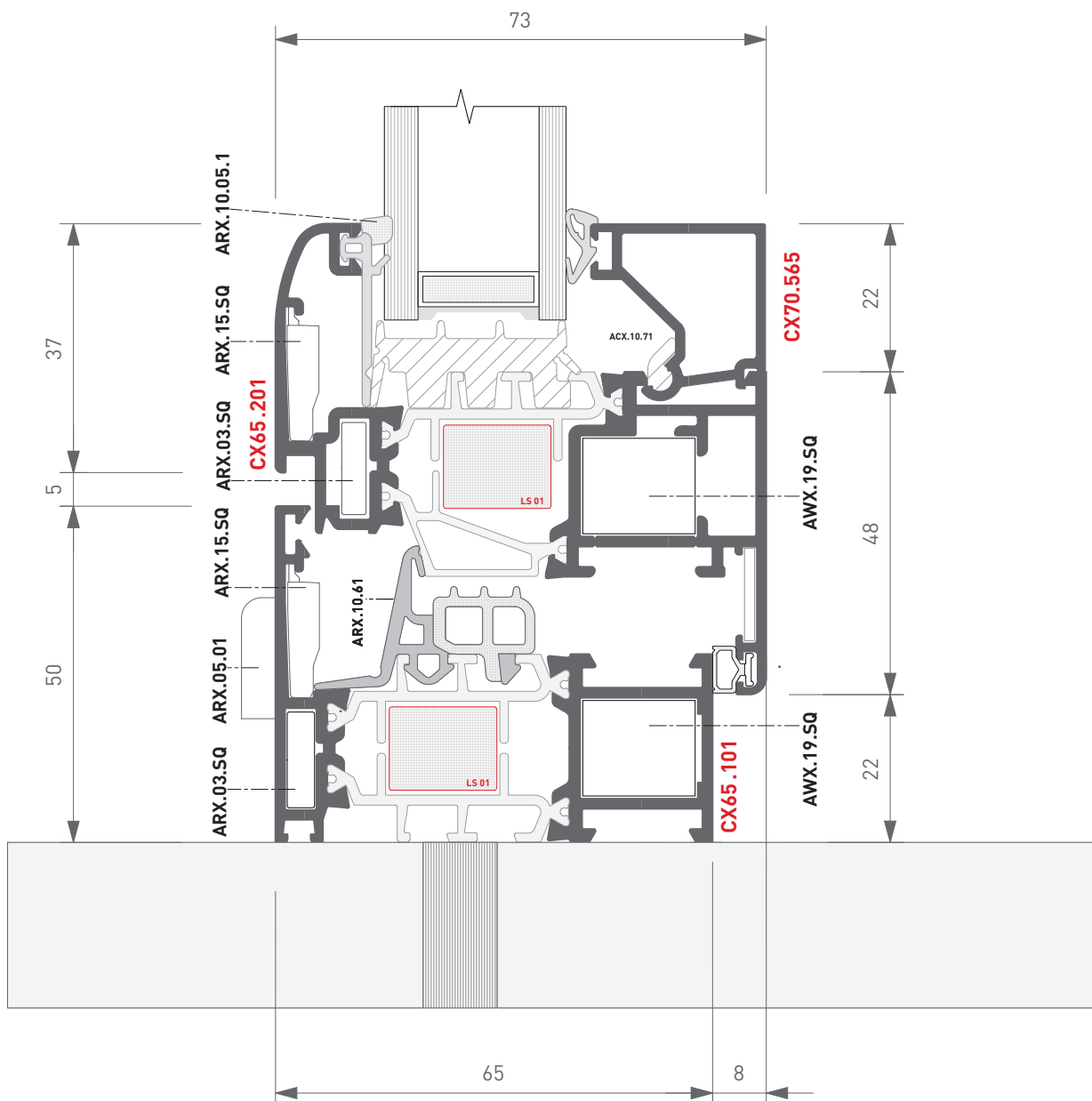
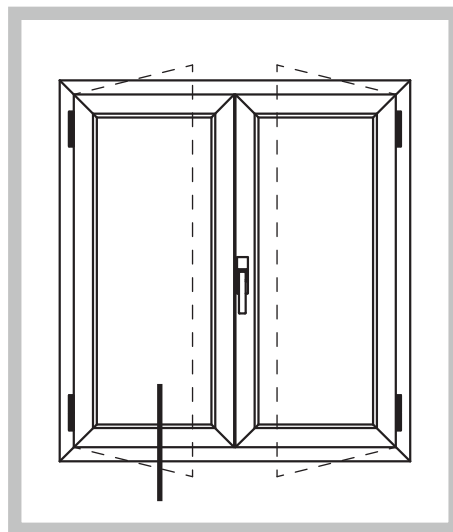



PORTA BALCONE A 2 ANTE
con fascia
DOUBLE SASH BALCONY DOOR
w/band

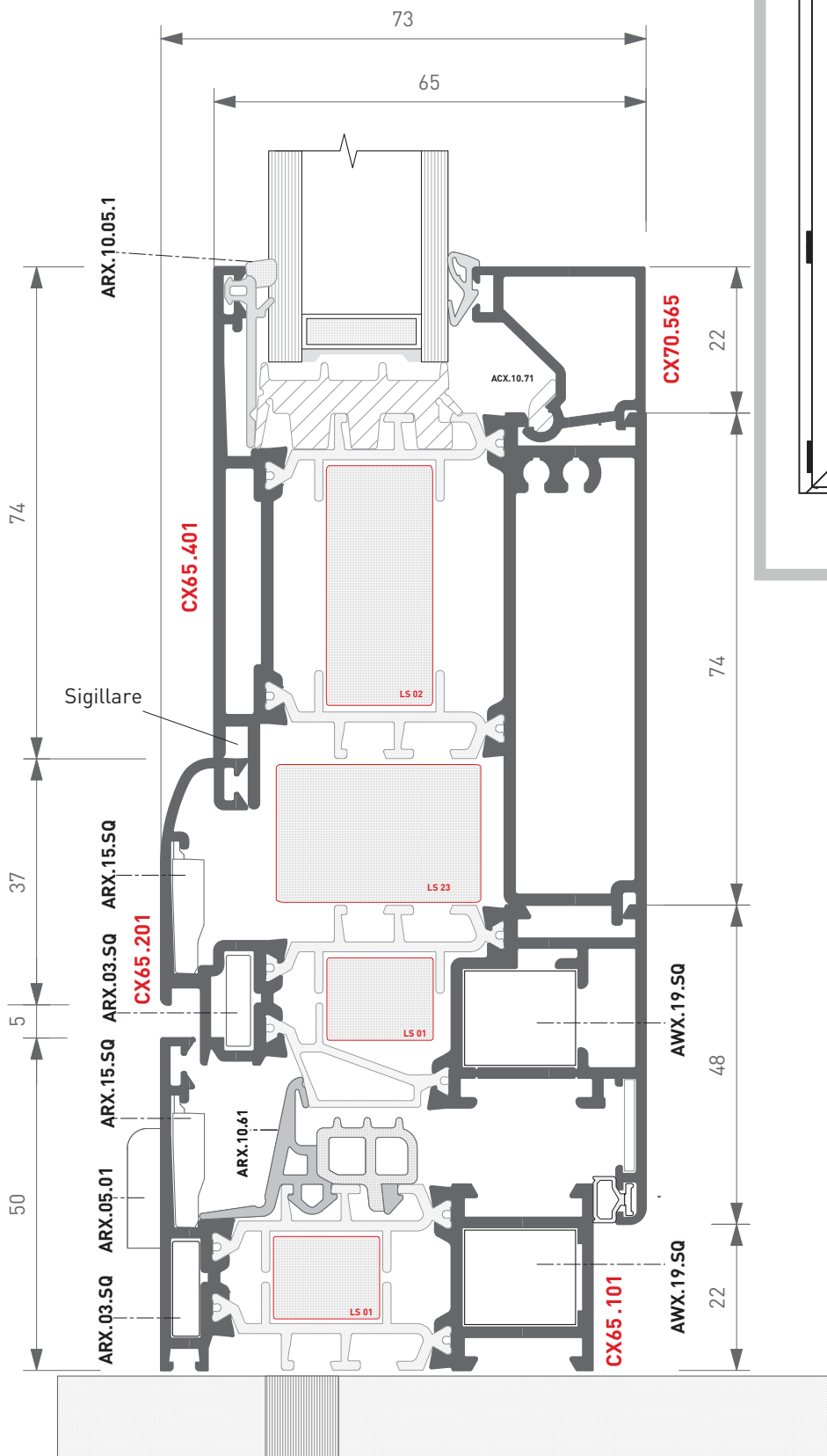
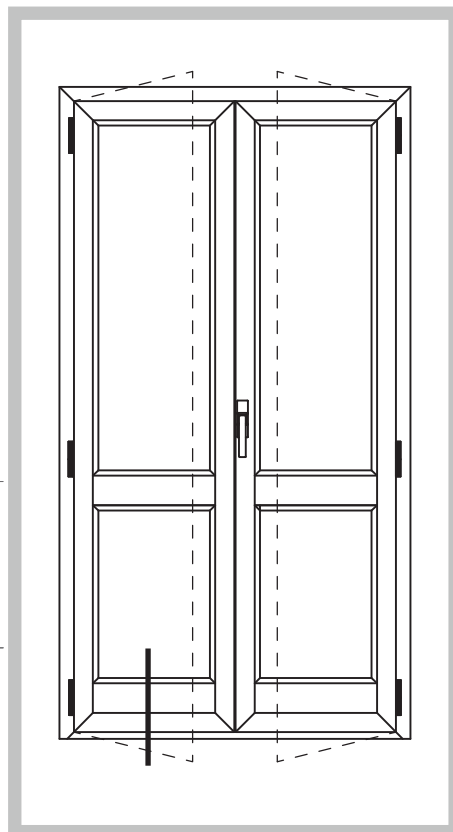



PORTA BALCONE A 2 ANTE
con soglia bassa
DOUBLE SASH BALCONY DOOR
W/LOW TRESHOLD

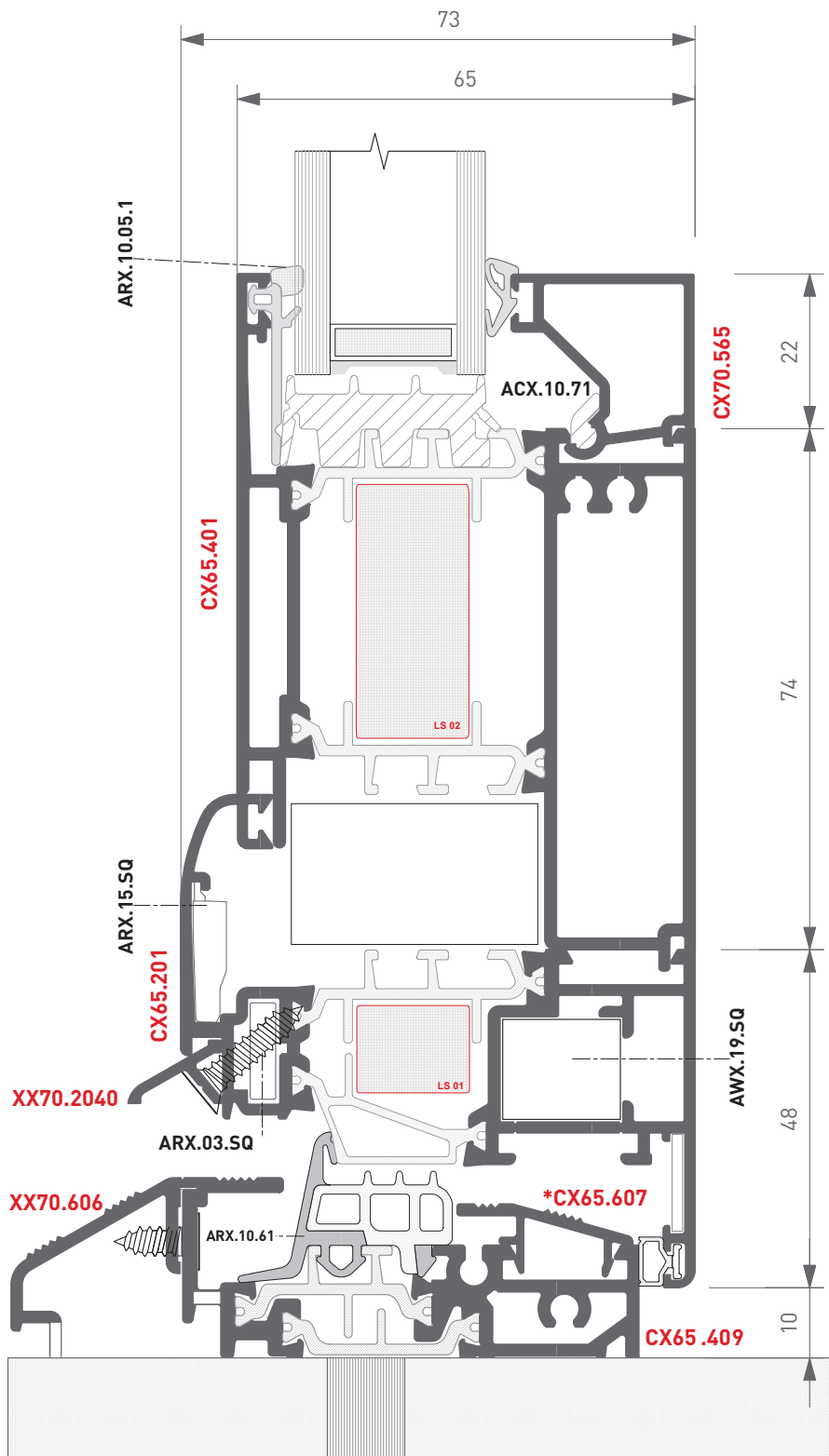
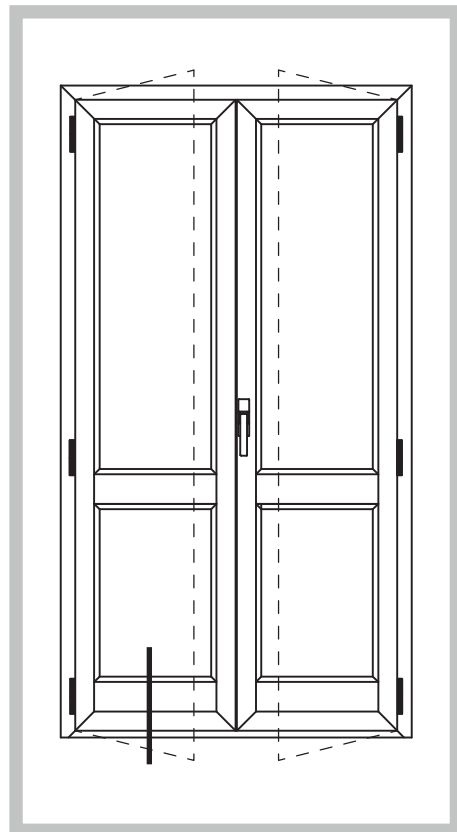

*Con il profilo **CX65.607** utilizzare accessorio **ARX.04.69X** nelle diverse finiture (vedi lista accessori)
Per i tagli del profilo vedi TAV G00

*With profile **CX65.607**, use accessory **ARX.04.69X** in the various finishes (see accessories list).
For cutting profile see pag. G00



PORTA BALCONE A 2 ANTE
DOUBLE SASH BALCONY DOOR

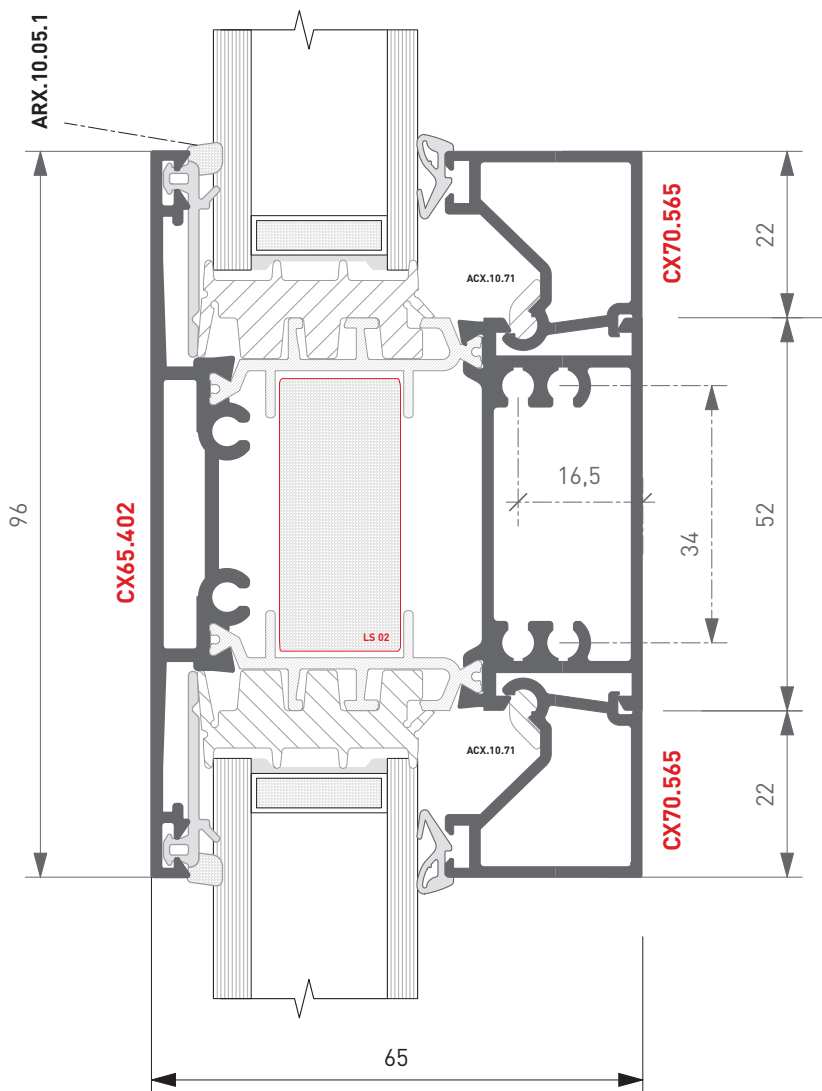
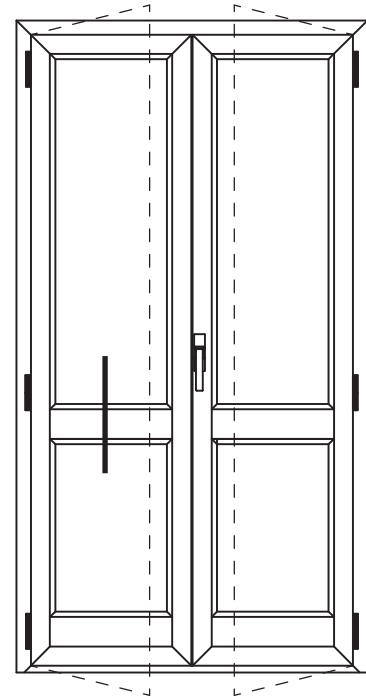



FINESTRA A 2 ANTE
DOUBLE SASH WINDOW

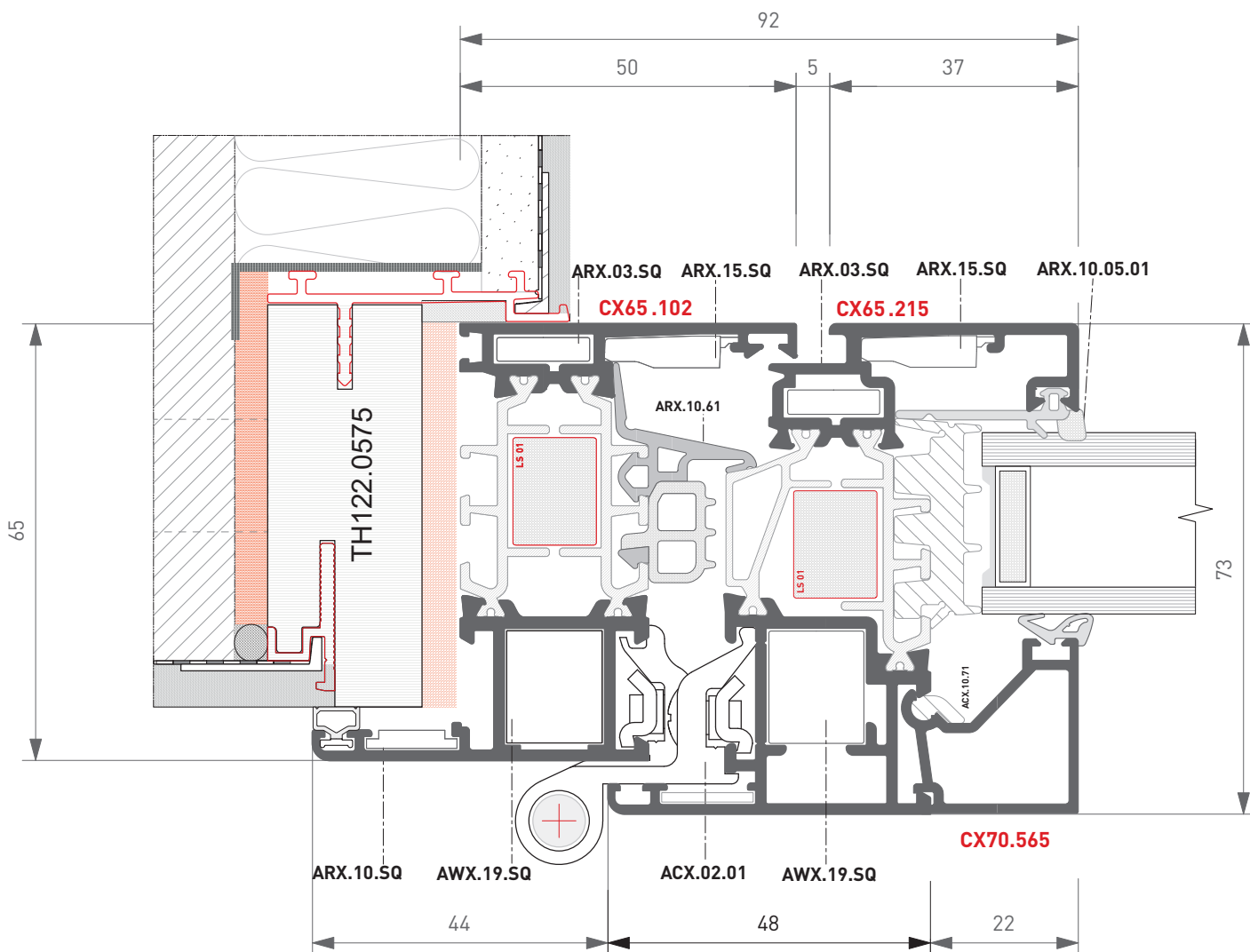
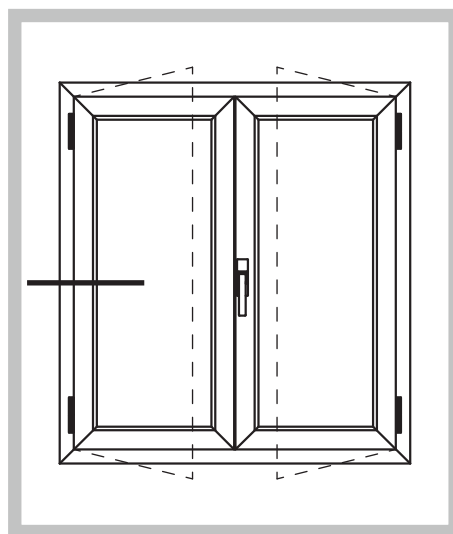



FINESTRA A 2 ANTE
DOUBLE SASH WINDOW

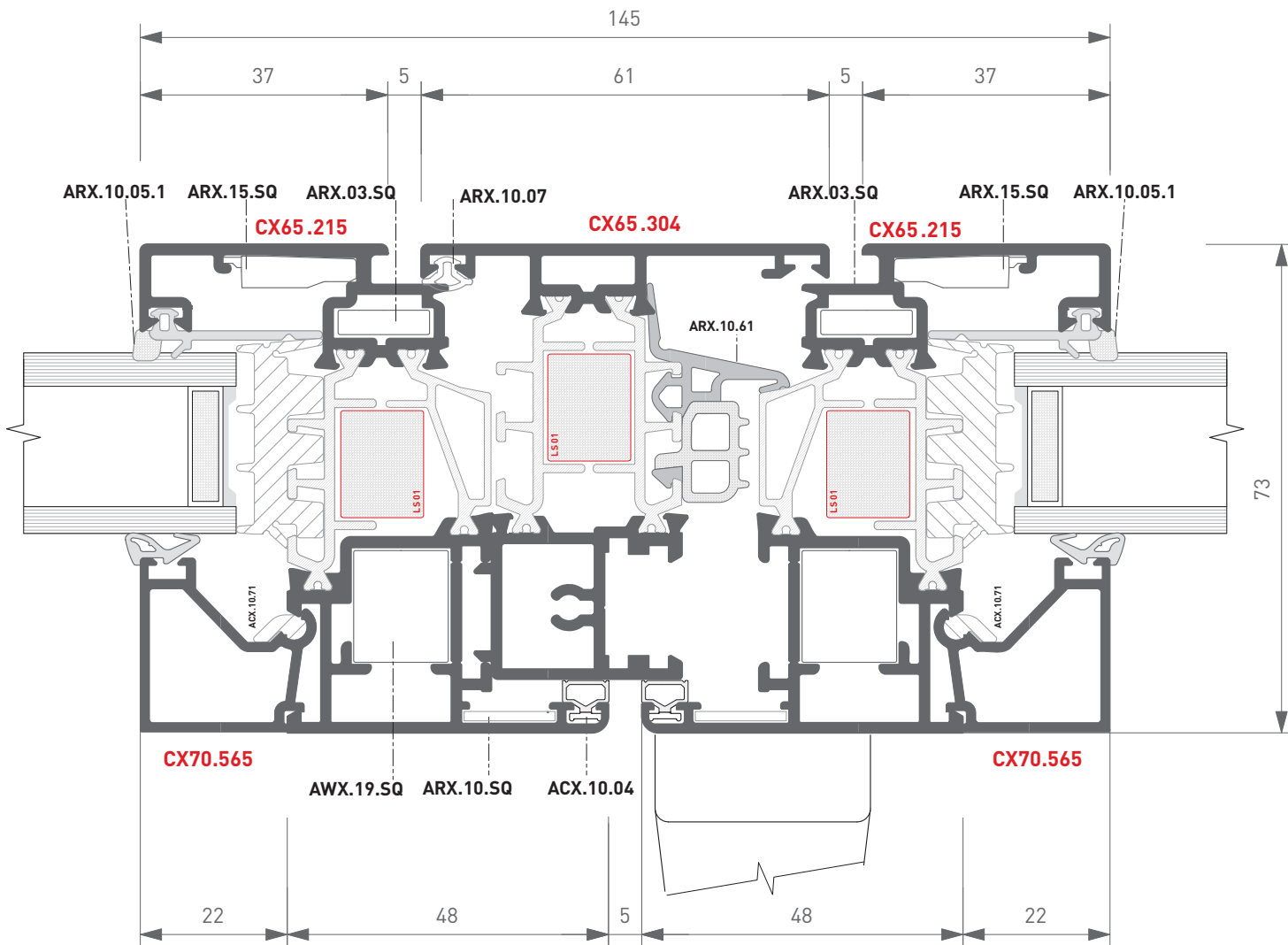
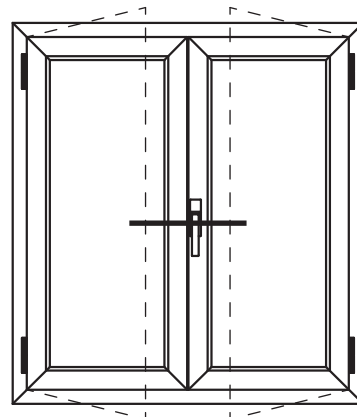



FINESTRA A 2 ANTE
Vetro ad infilare
DOUBLE SASH WINDOW
Insert Glass

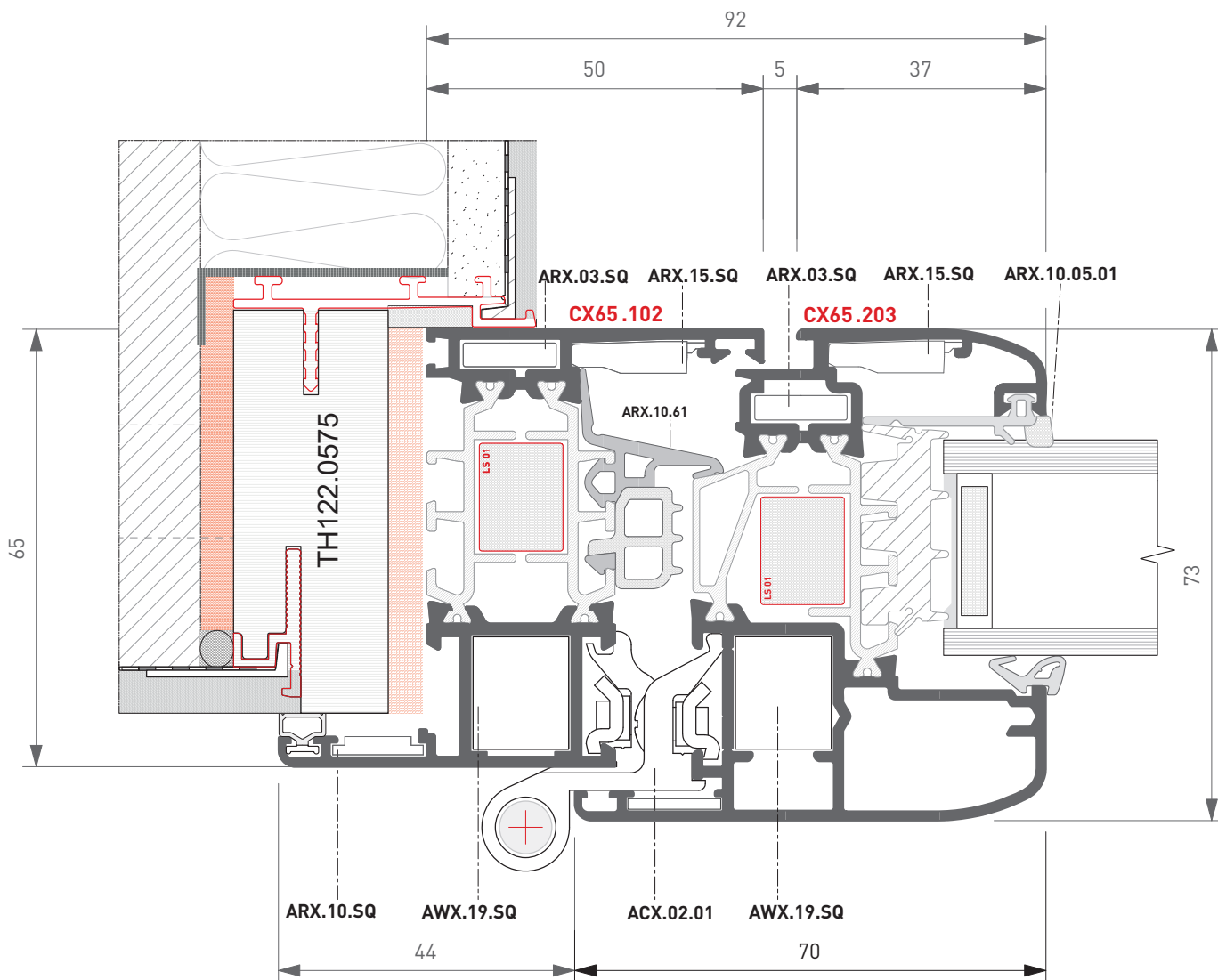
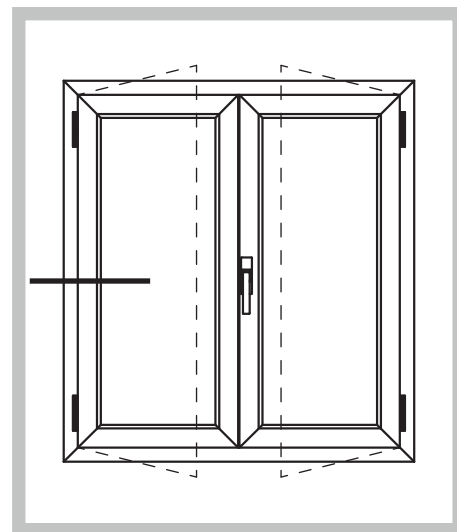



FINESTRA A 2 ANTE
Vetro ad infilare
DOUBLE SASH WINDOW
Insert Glass

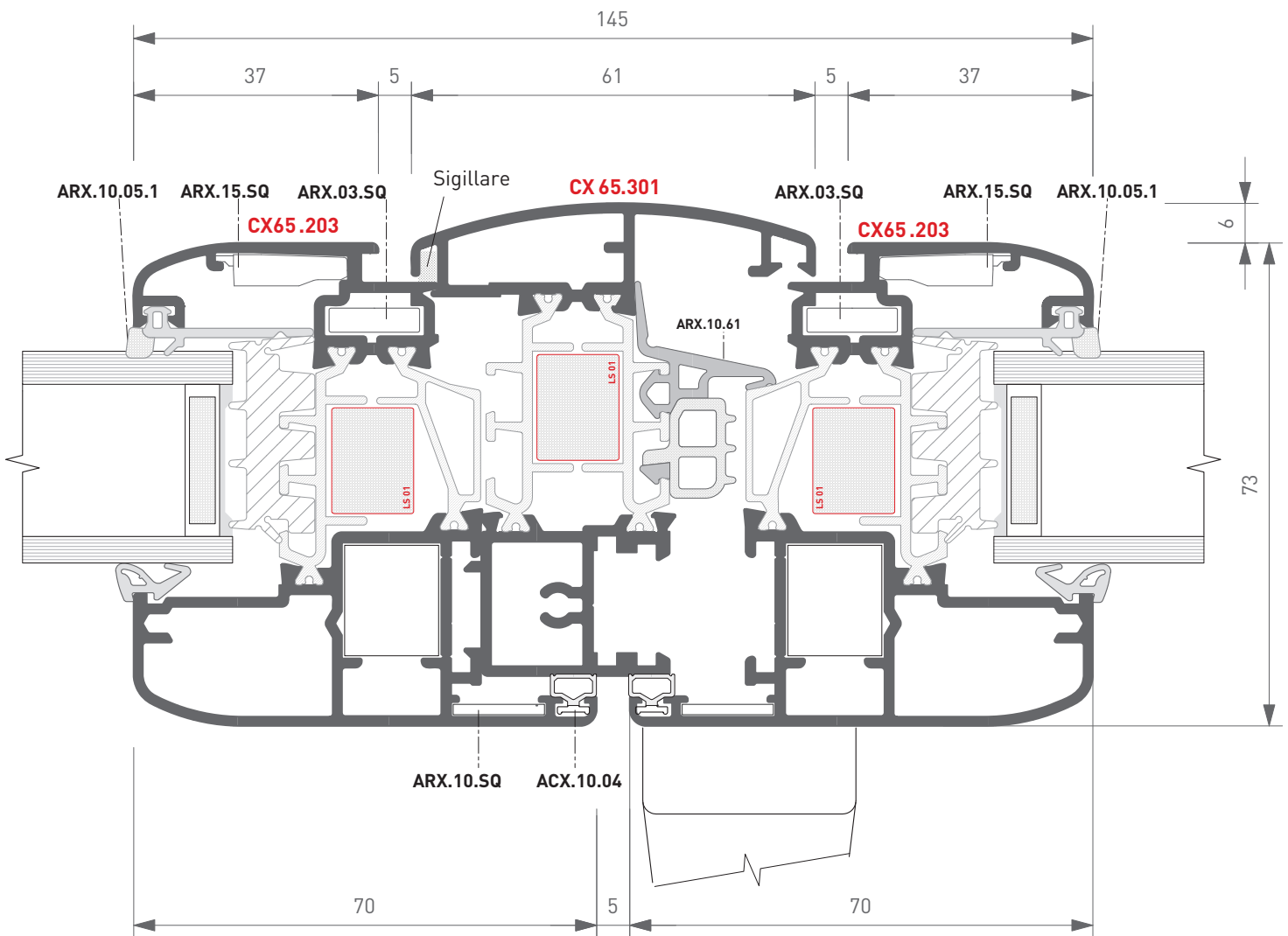
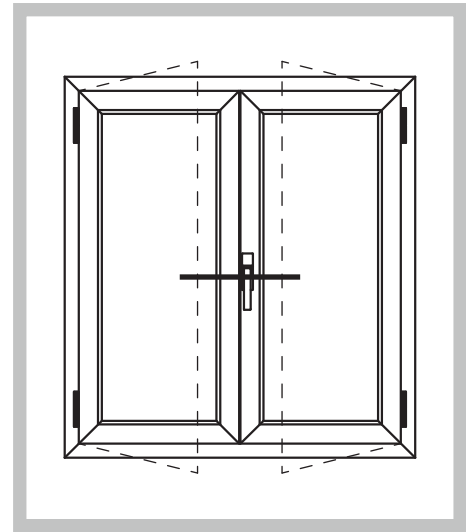



PORTA BALCONE A 2 ANTE
con fascia | Vetro ad infilare
DOUBLE SASH BALCONY DOOR
w/band | Insert Glass

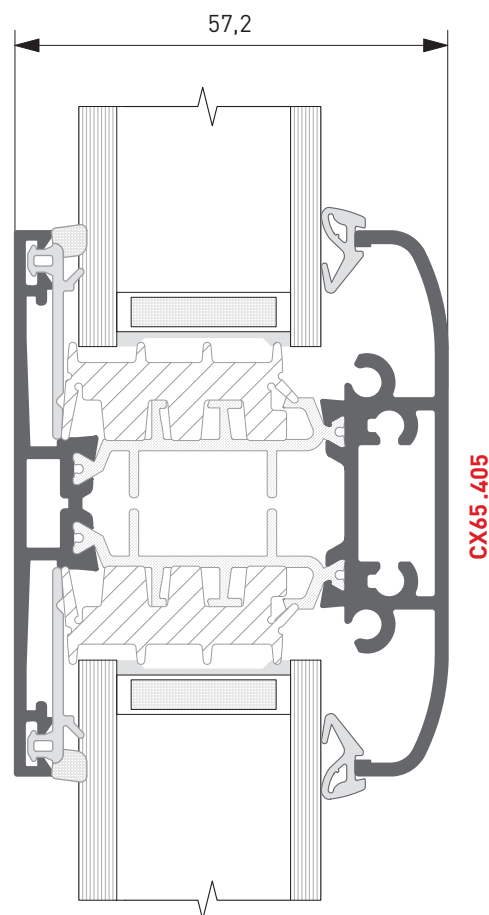
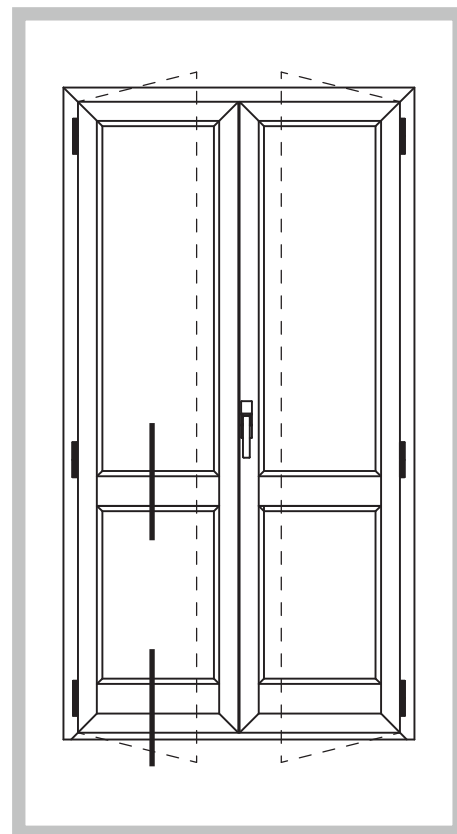
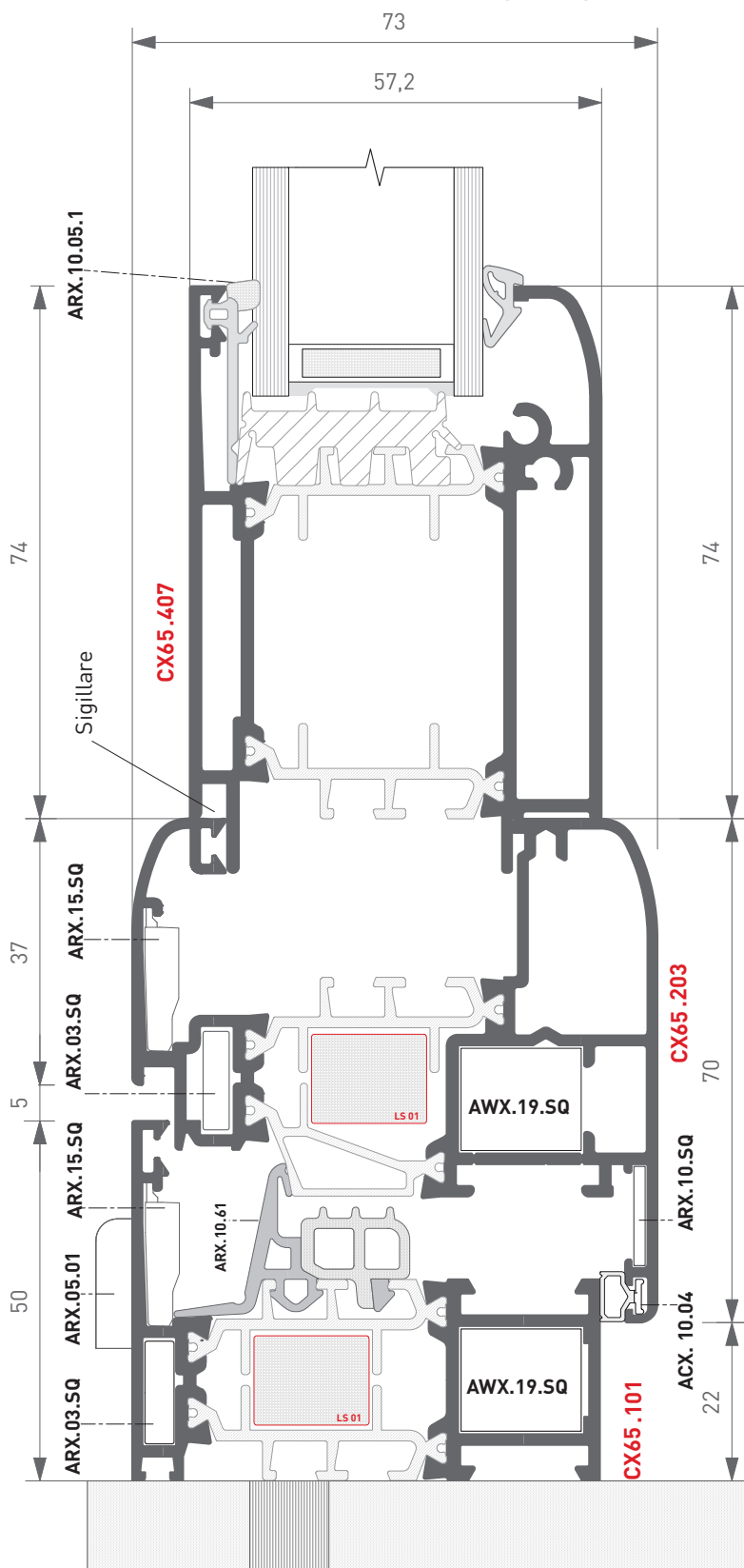



FINESTRA A 2 ANTE
Vetro ad infilare
DOUBLE SASH WINDOW
Insert Glass

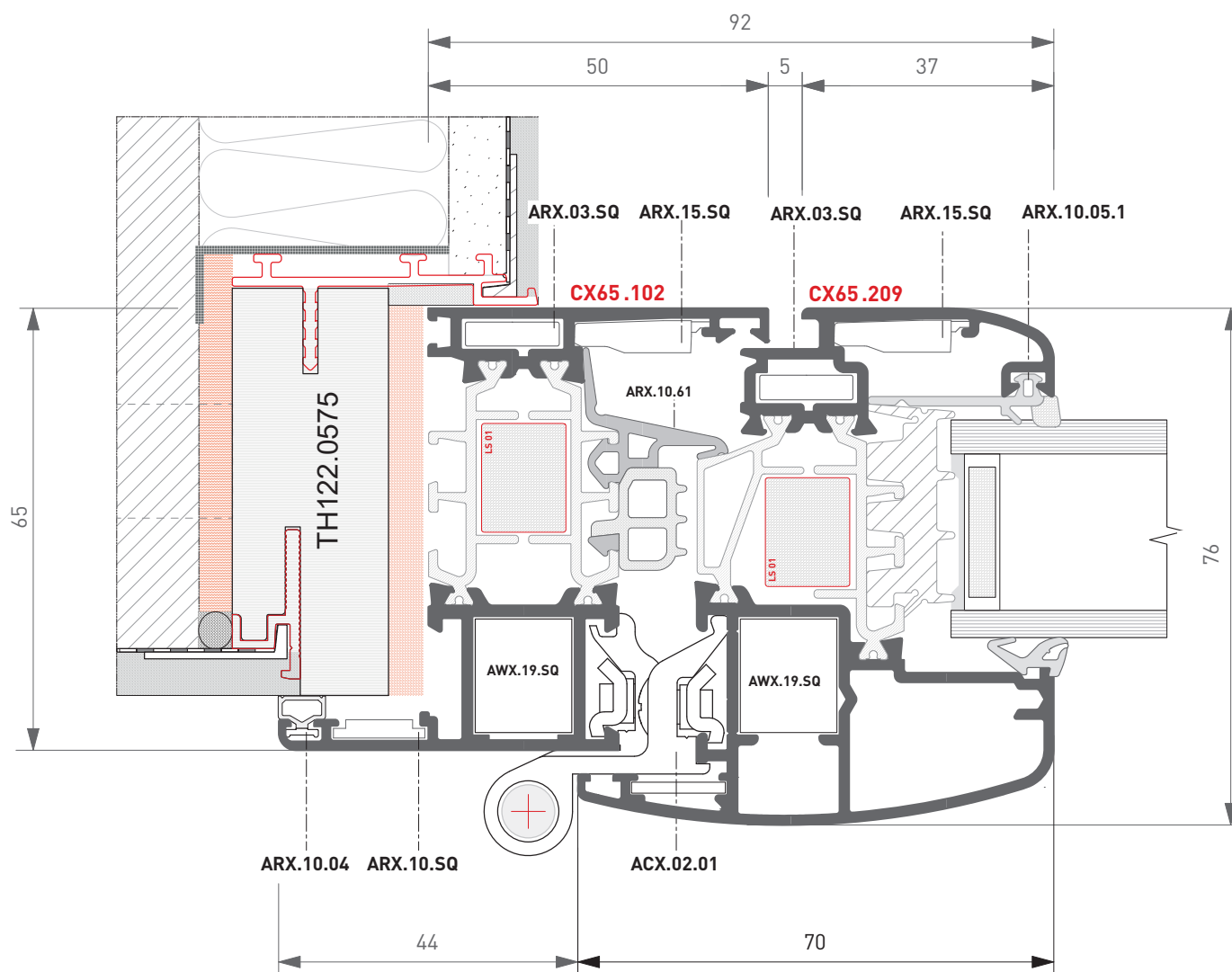
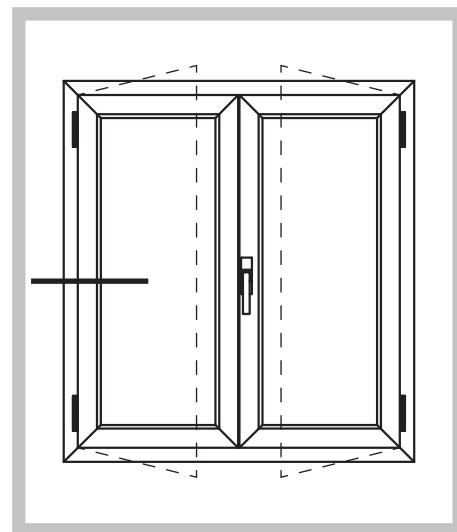



FINESTRA A 2 ANTE
Vetro ad infilare
DOUBLE SASH WINDOW
Insert Glass

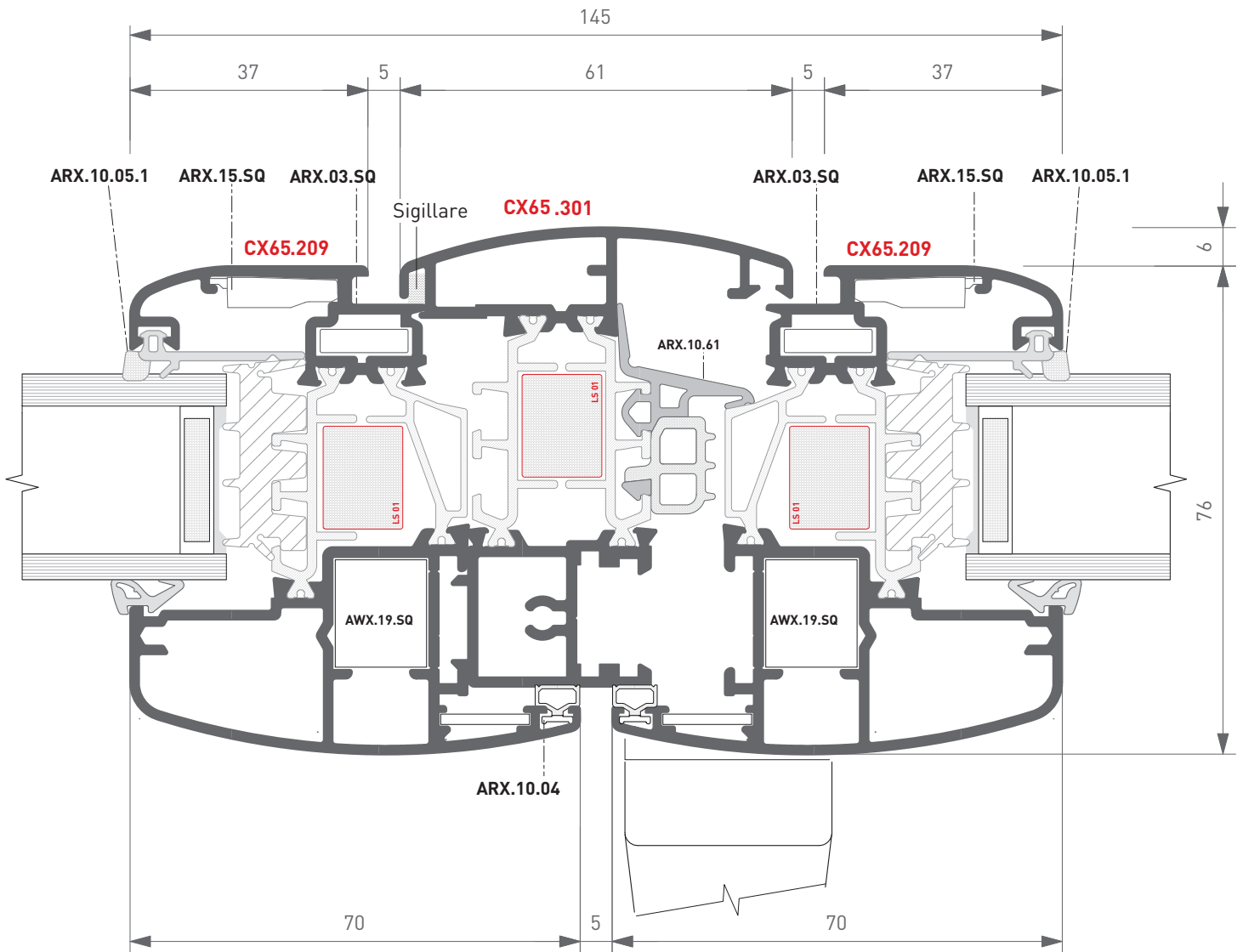
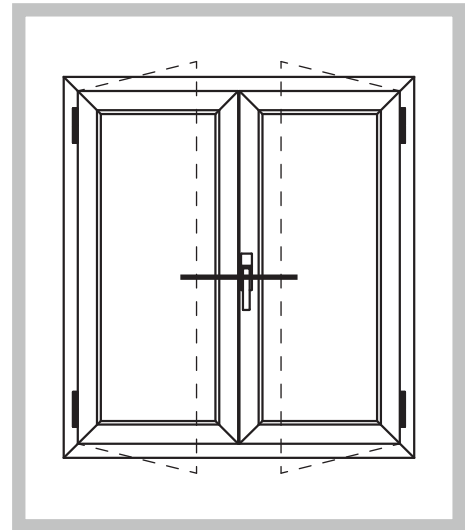



FINESTRA A 2 ANTE
Vetro ad infilare
DOUBLE SASH WINDOW
Insert Glass

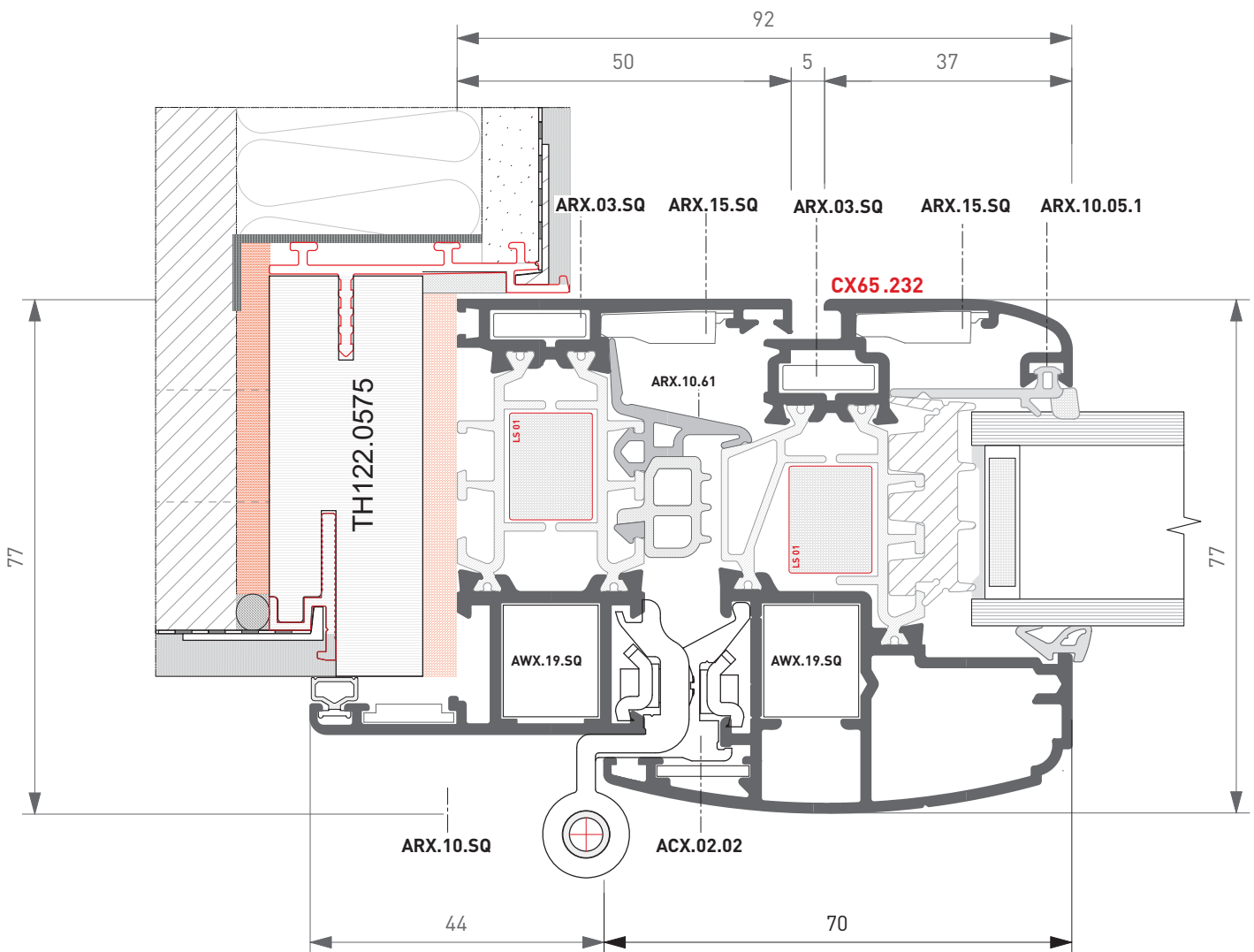
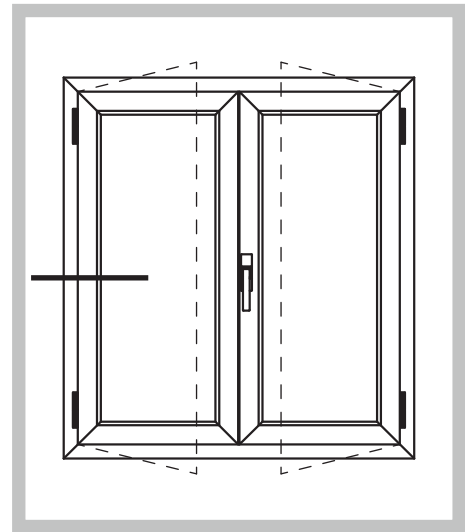



FINESTRA A 2 ANTE
Vetro ad infilare
DOUBLE SASH WINDOW
Insert Glass

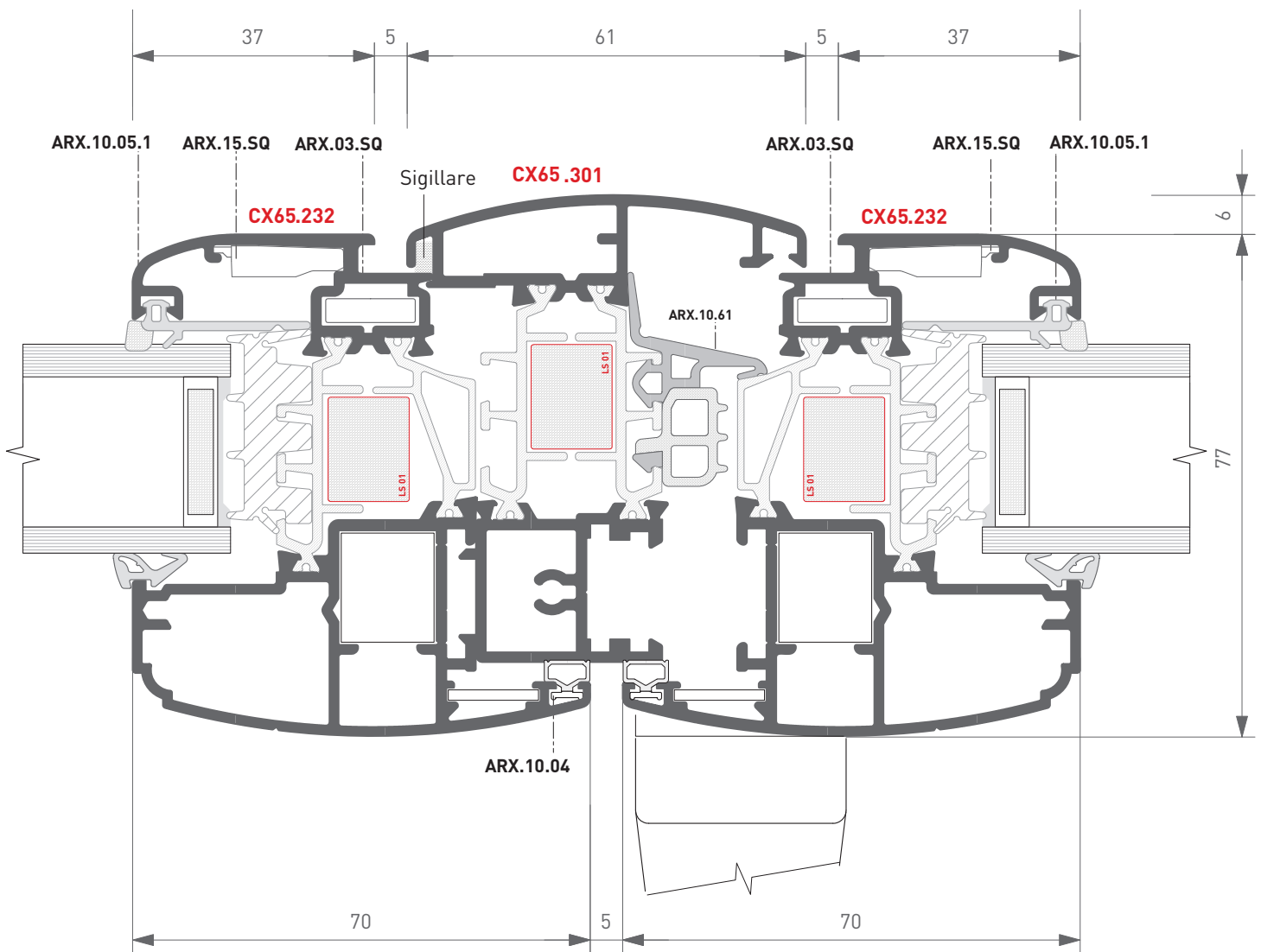
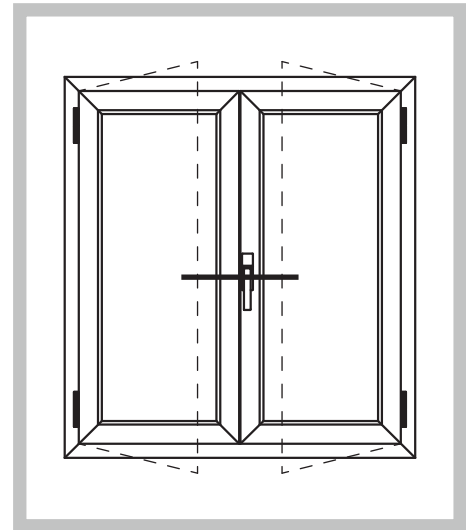



PORTA BALCONE A 2 ANTE
con fascia | Vetro ad infilare
DOUBLE SASH BALCONY DOOR
w/band | Insert Glass

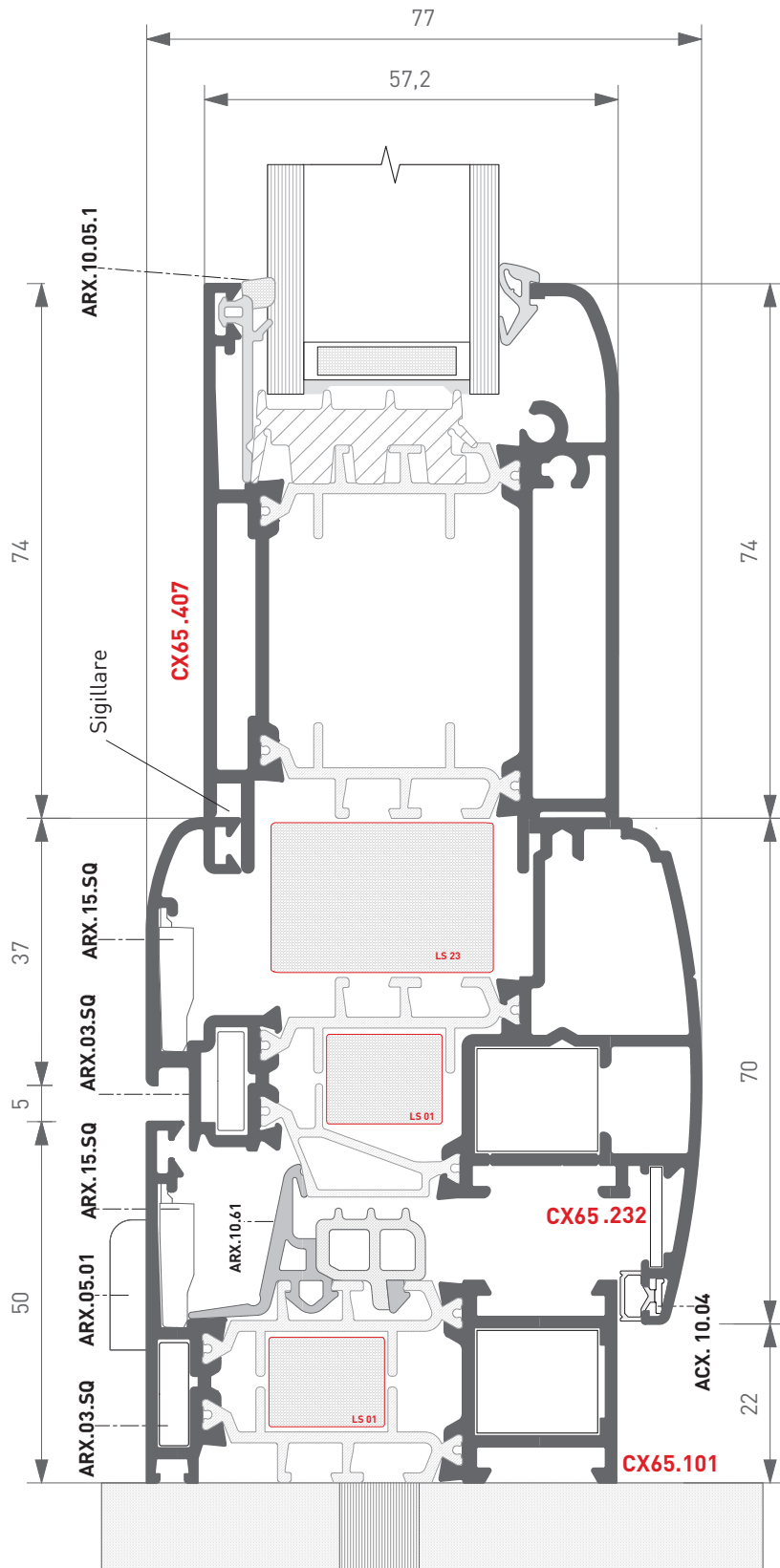
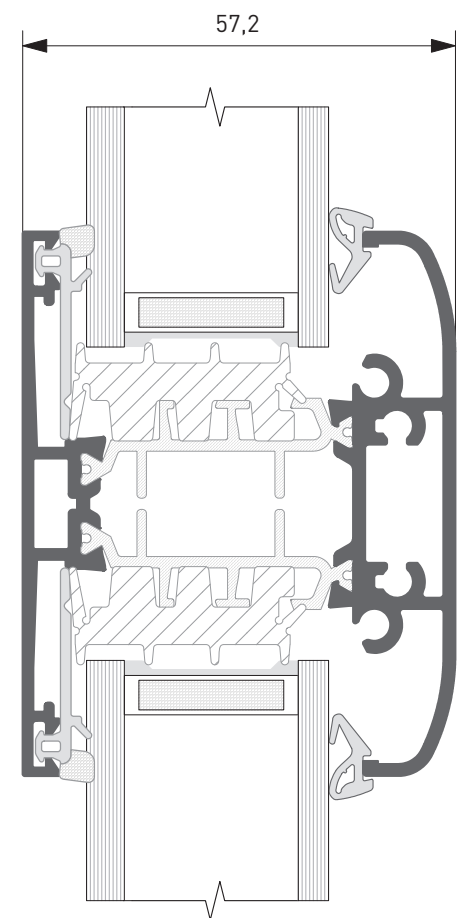
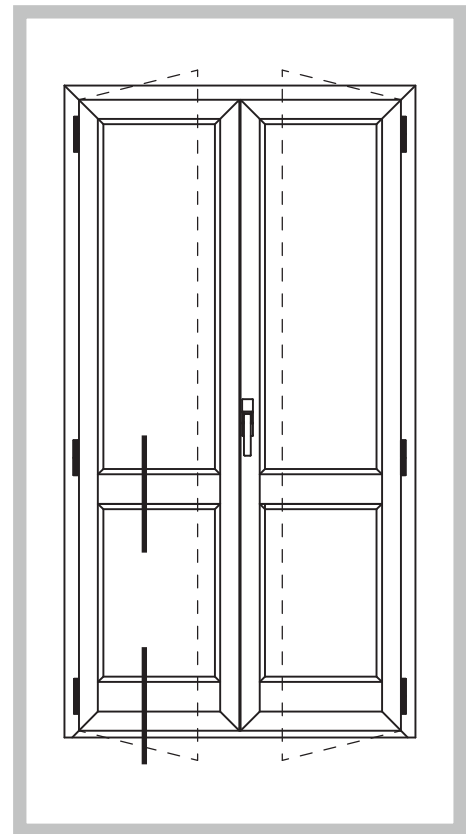



FINESTRA BILICO VERTICALE
VERTICAL PIVOT WINDOW

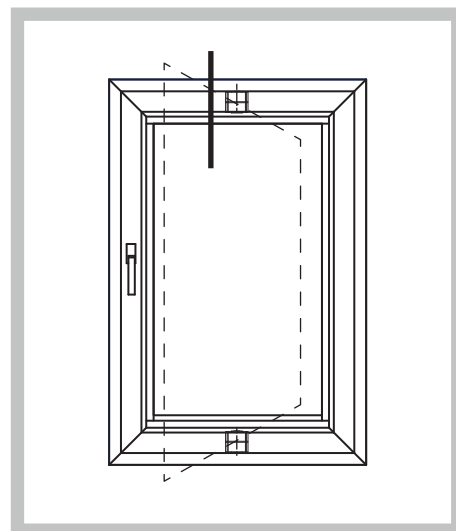
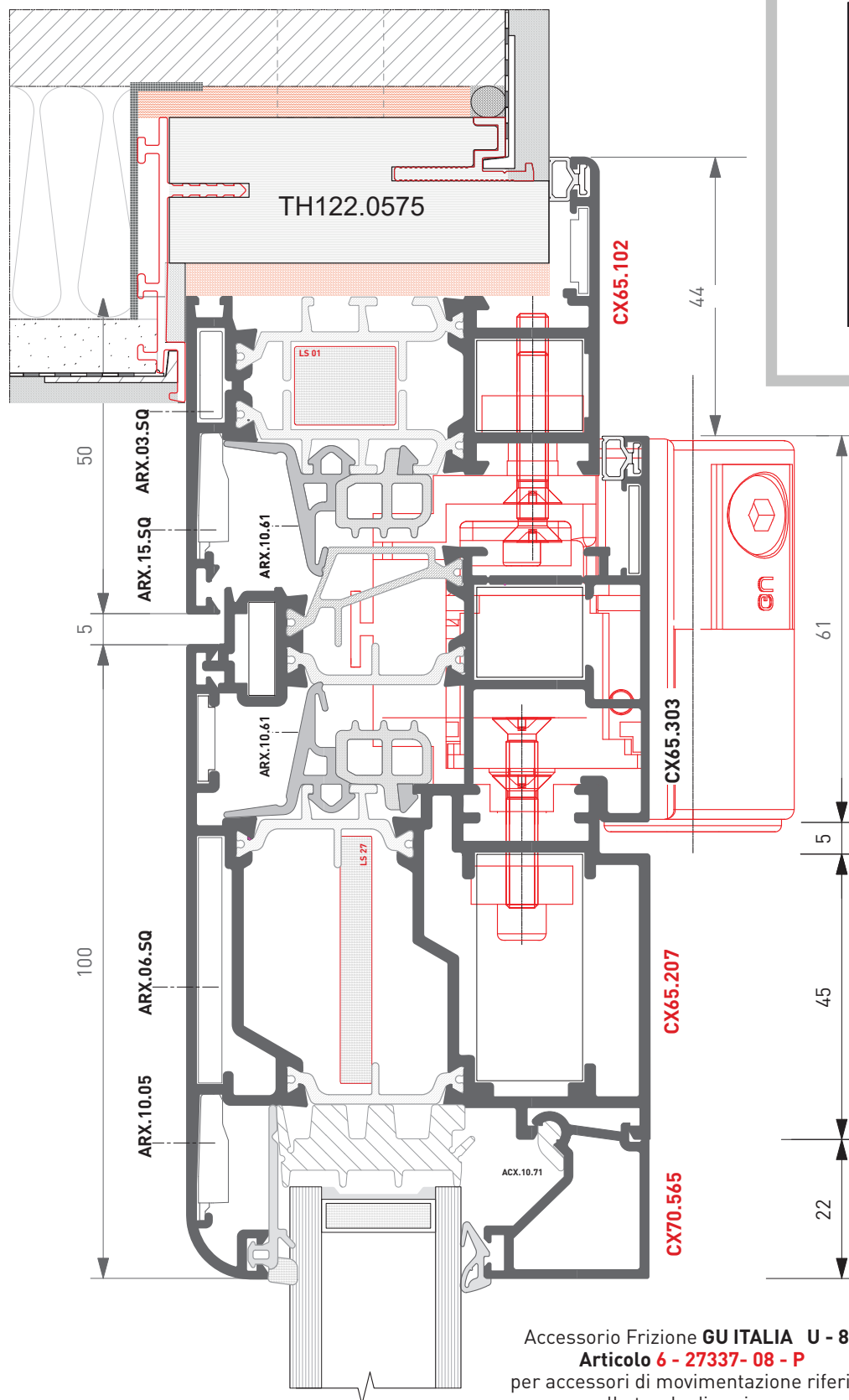

Accessorio Frizione **GU ITALIA U - 88**
Articolo 6 - 27337-08 - P
per accessori di movimentazione riferirsi
alla tavola di assieme
Friction Item GU ITALIA U - 88
Item 6 - 27337-08 - P
for movement accessories refer to overview table



ELEMENTO FISSO VERTICALE
VERTICAL FIXED GLASS

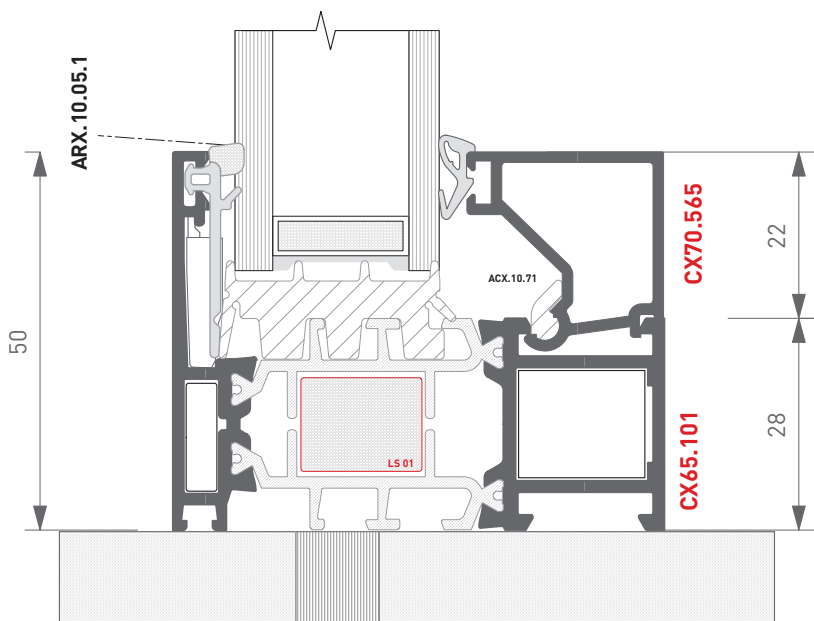
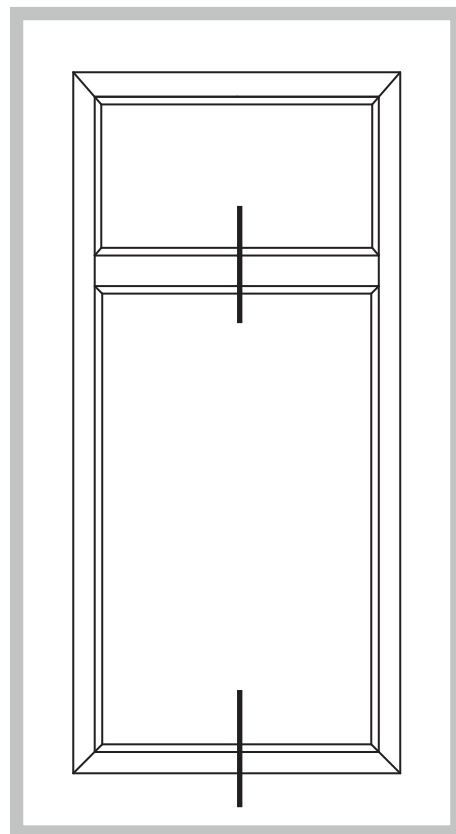
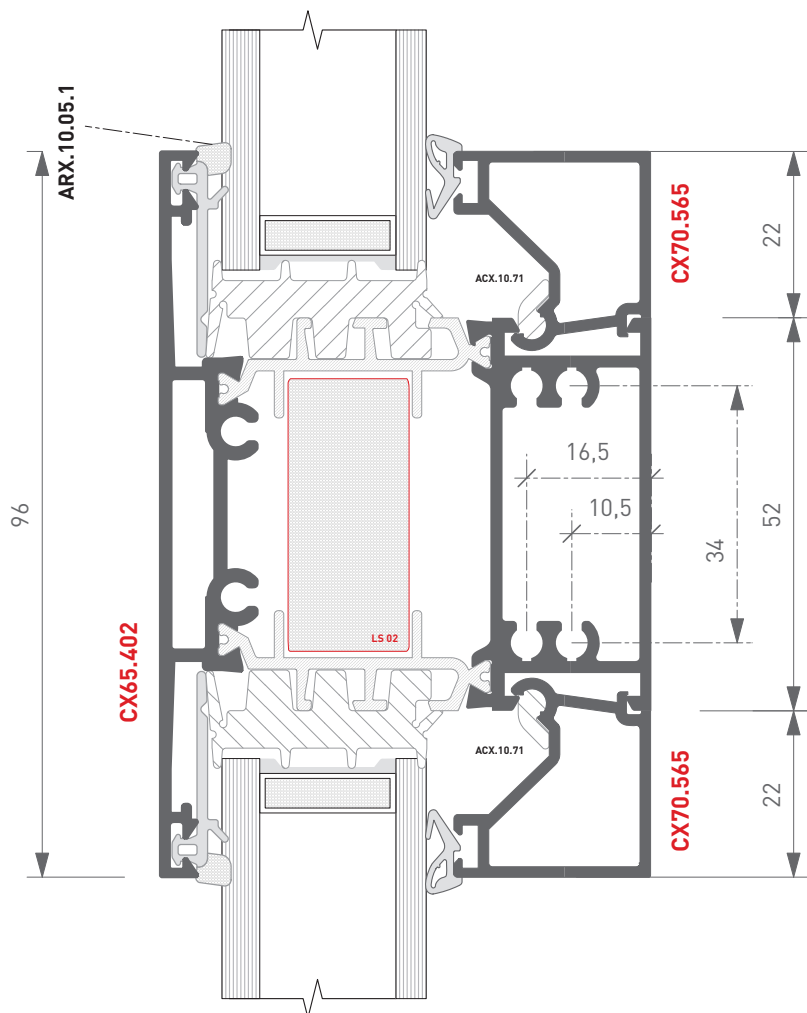



Ferramenta a Nastro
Tape Hardware

FINESTRA A 2 ANTE
DOUBLE SASH WINDOW

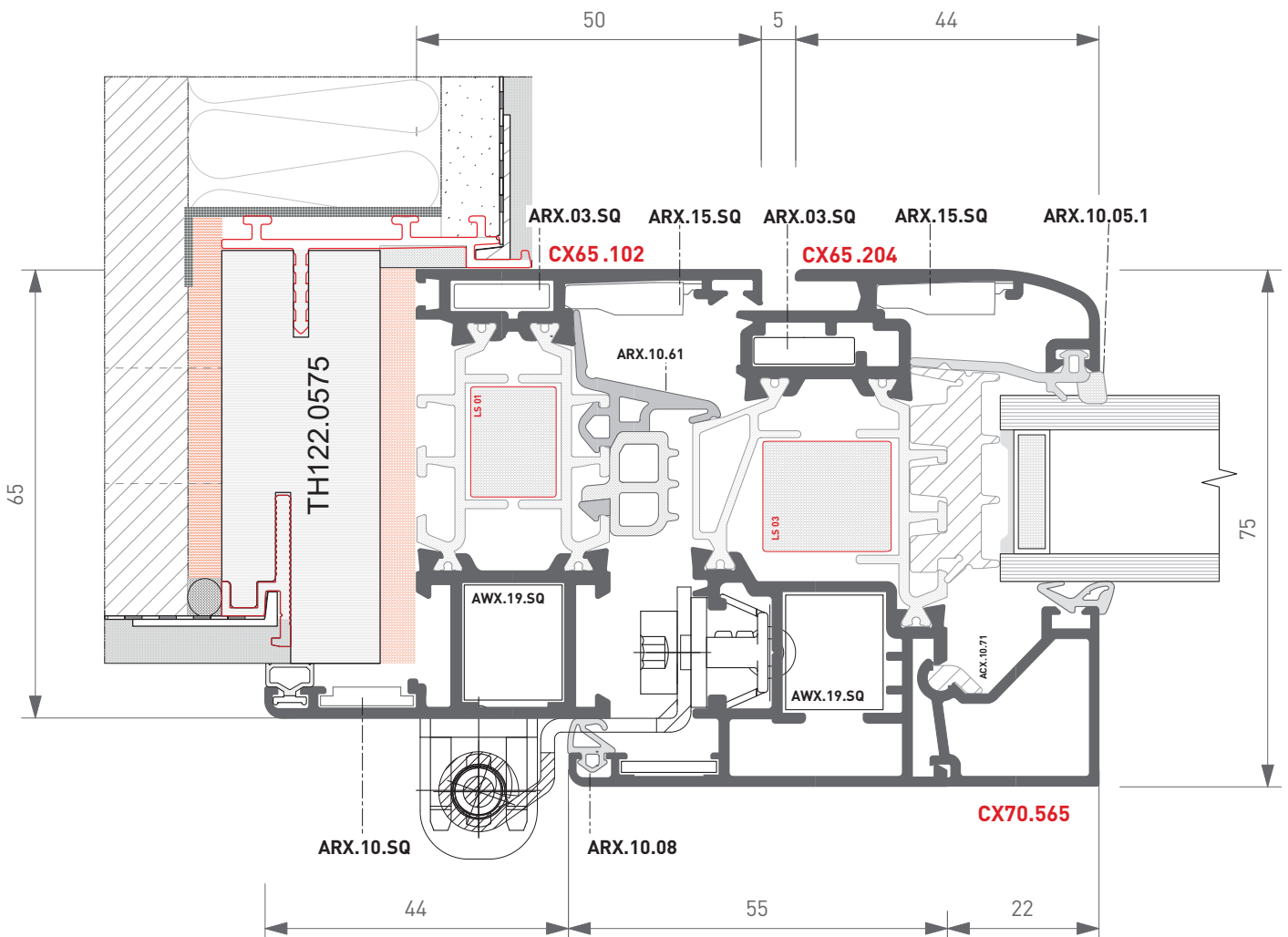
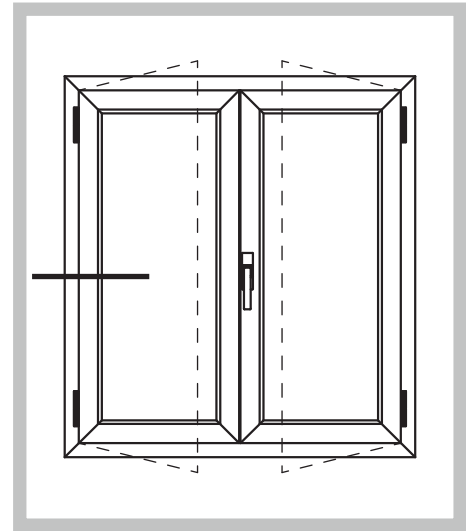



Ferramenta a Nastro
Tape Hardware

FINESTRA A 2 ANTE
DOUBLE SASH WINDOW

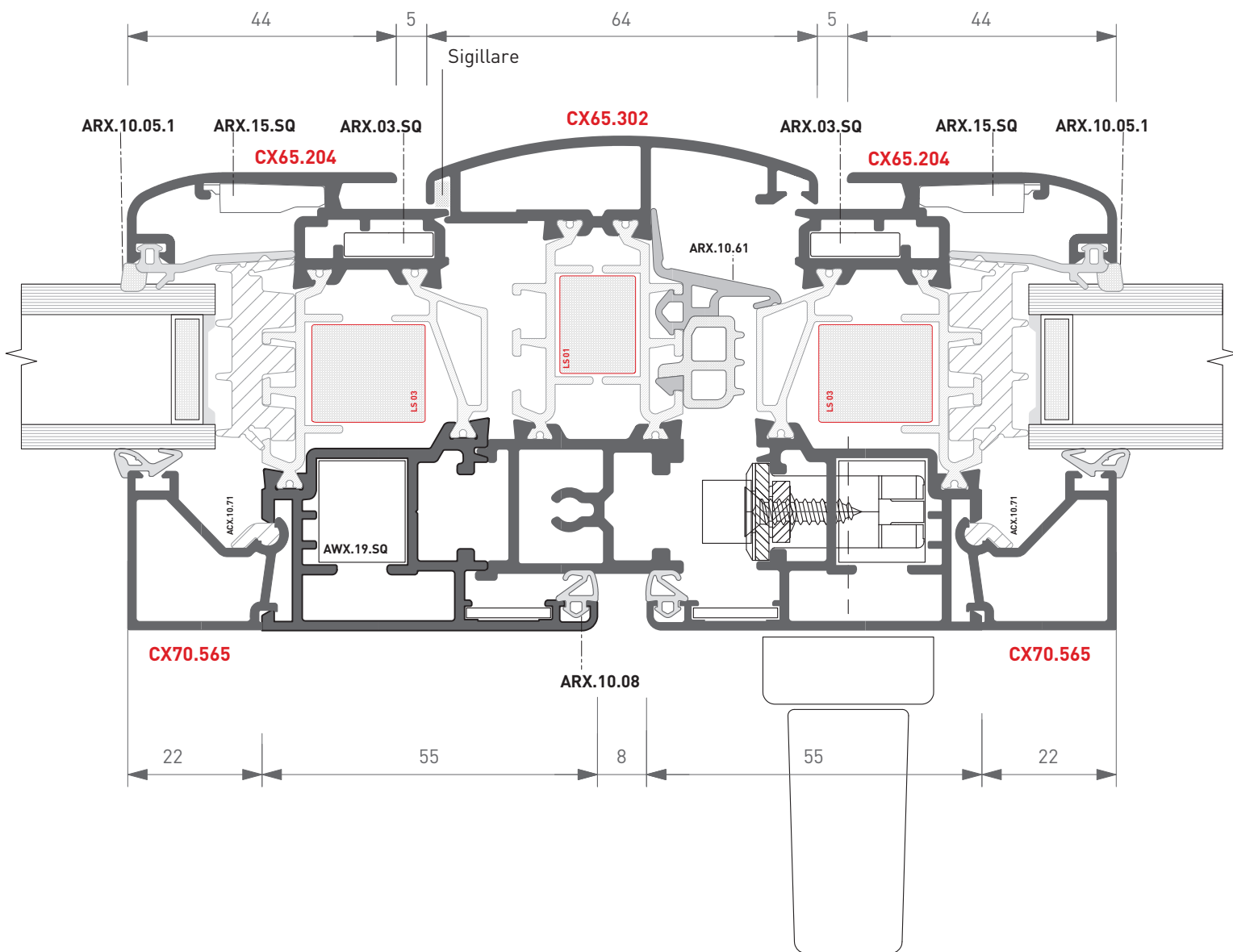
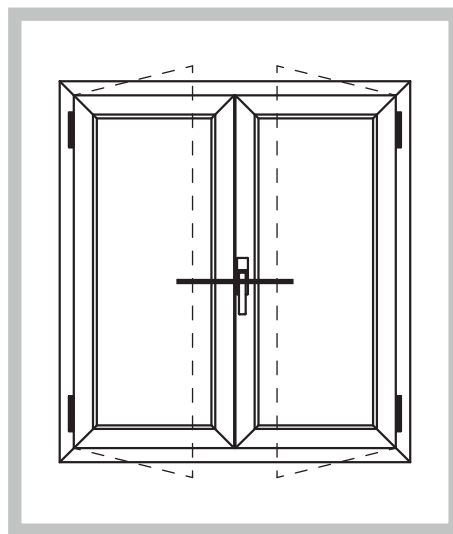



FINESTRA A 2 ANTE
Scorrevole in parallelo
DOUBLE SASH WINDOW
Parallel Sliding

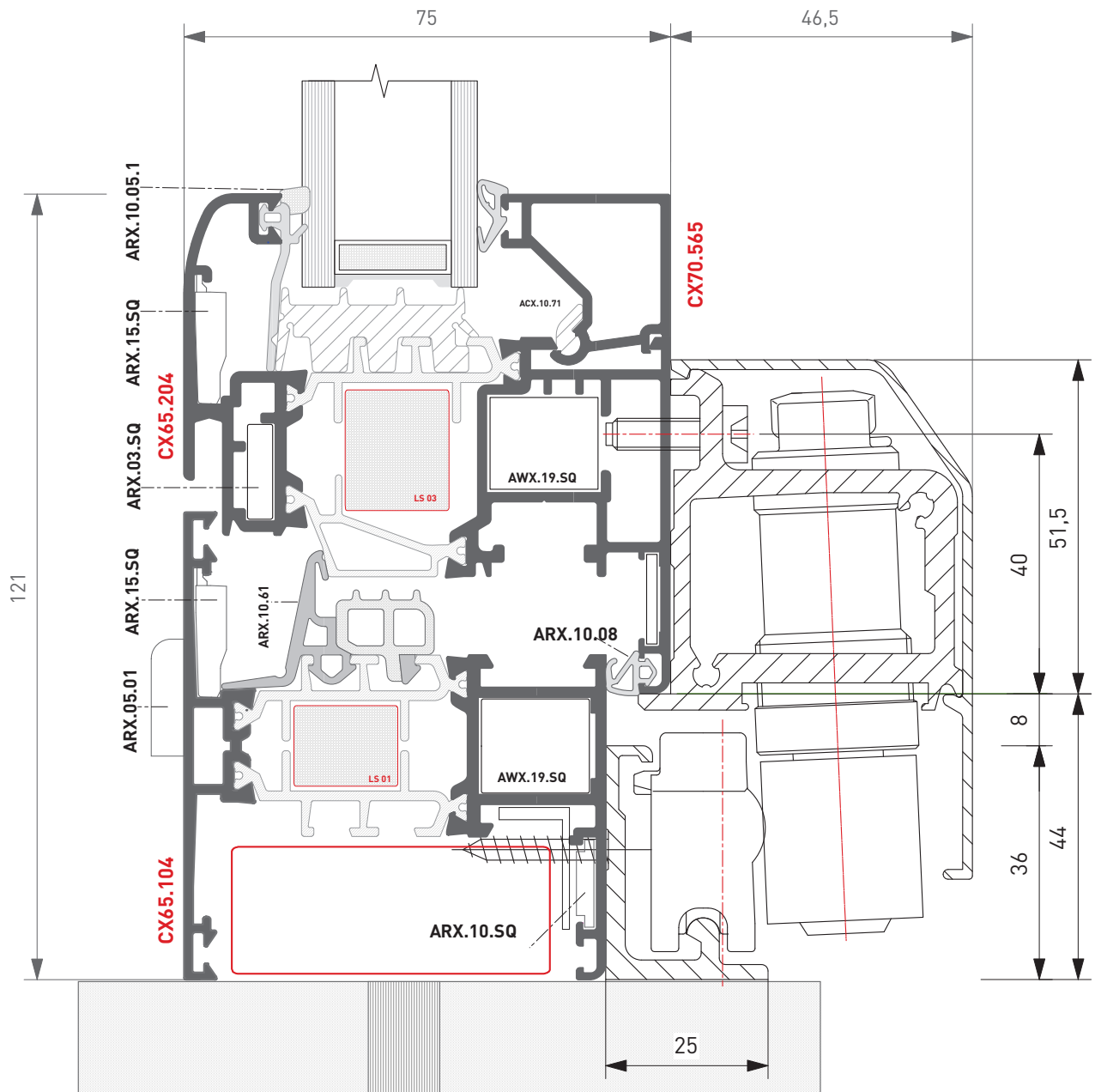
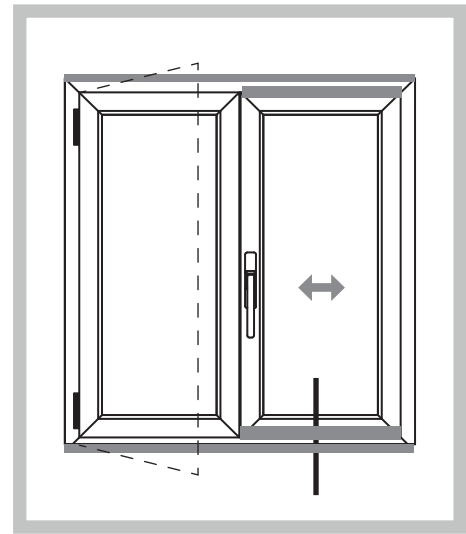



Ferramenta a Nastro
Tape Hardware

FINESTRA A 2 ANTE
Scorrevole in parallelo
DOUBLE SASH WINDOW
Parallel Sliding

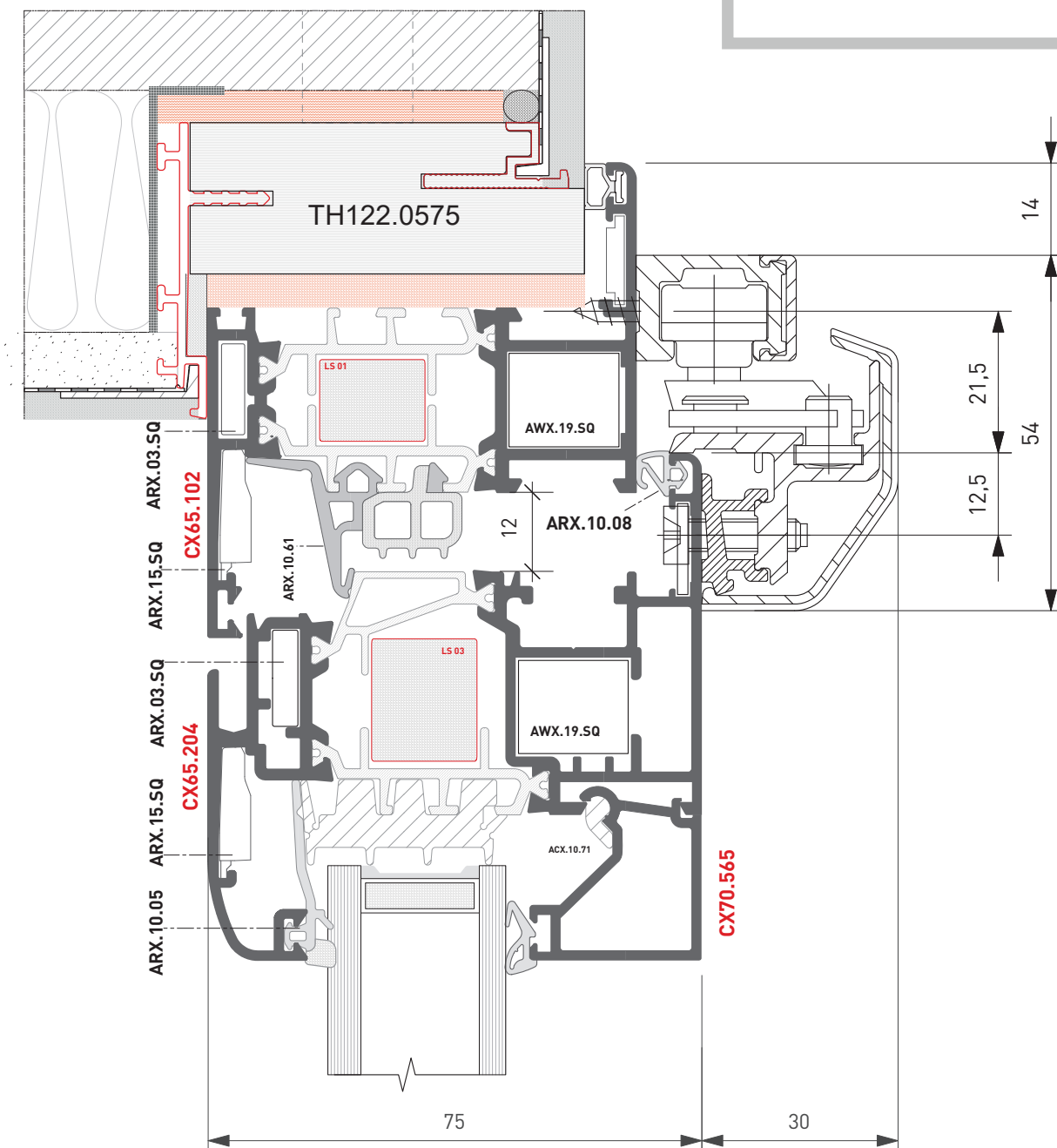
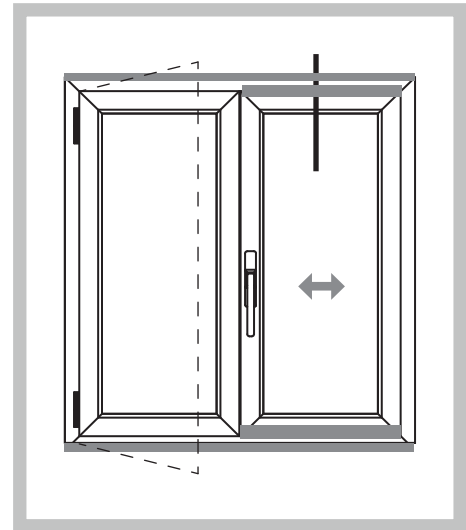



Ferramenta a Nastro
Tape Hardware

PORTA BALCONE A 2 ANTE
con fascia
DOUBLE SASH BALCONY DOOR
w/band

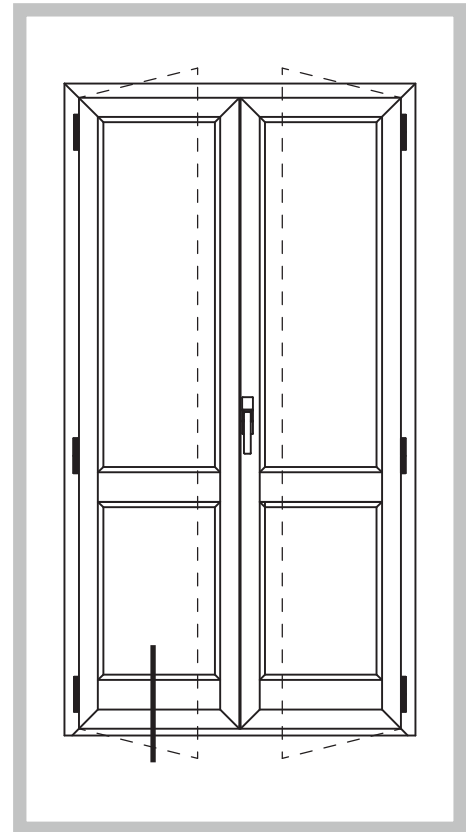
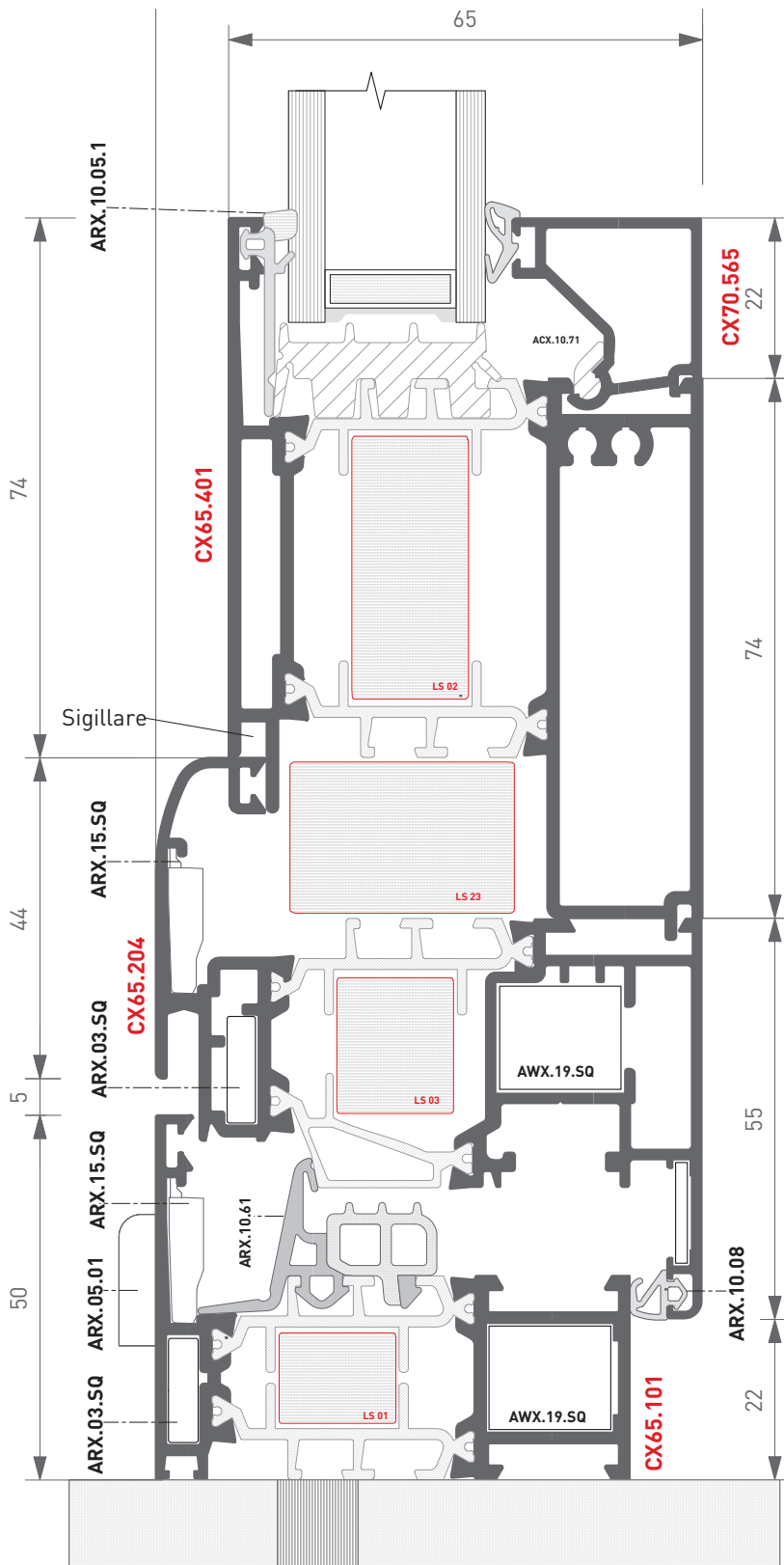



Ferramenta a Nastro
Tape Hardware

PORTA BALCONE A 2 ANTE
DOUBLE SASH BALCONY DOOR

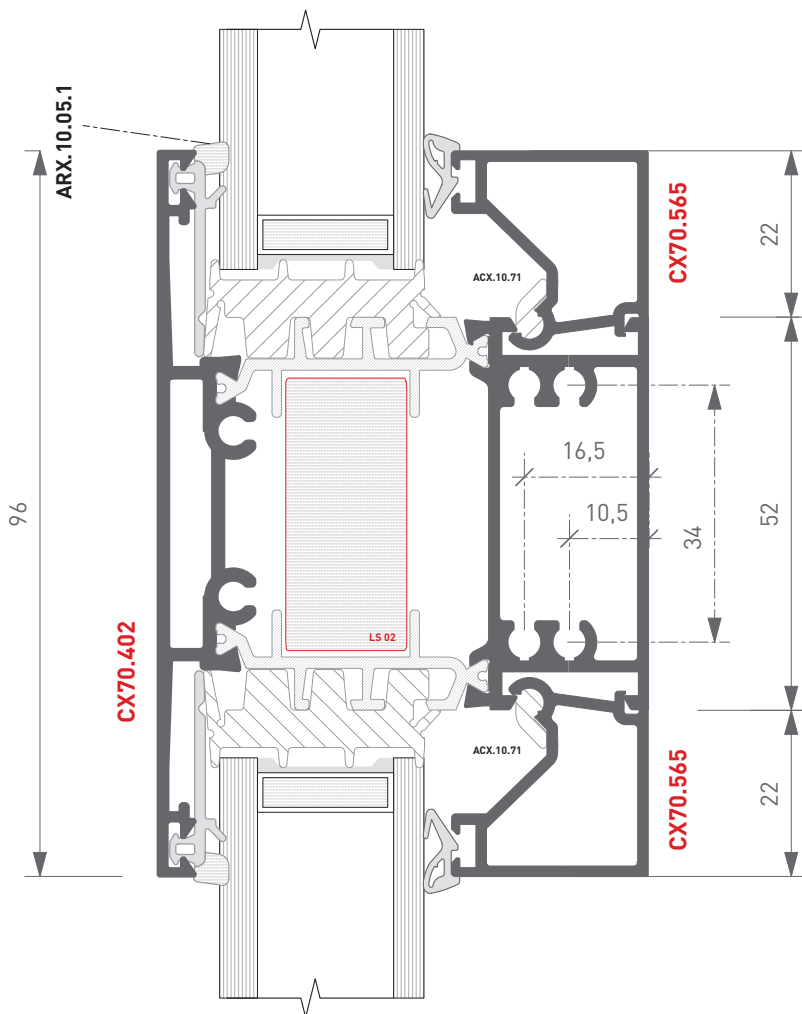
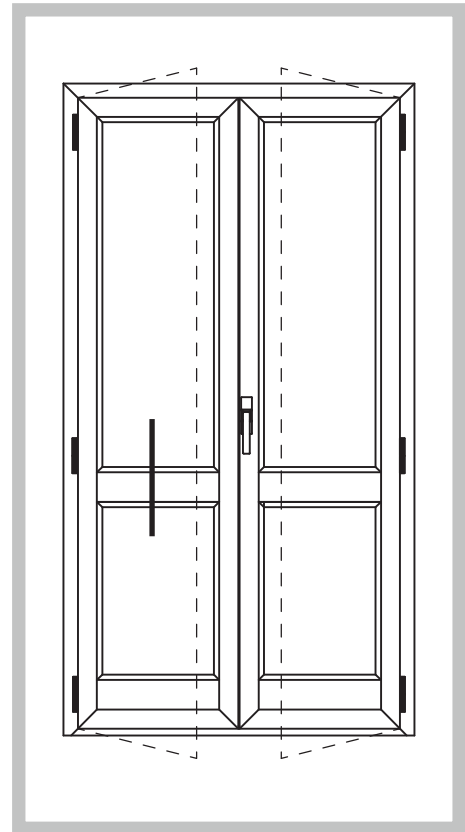



FINESTRA
BILICO ORIZZONTALE
HORIZONTAL PIVOT
WINDOW

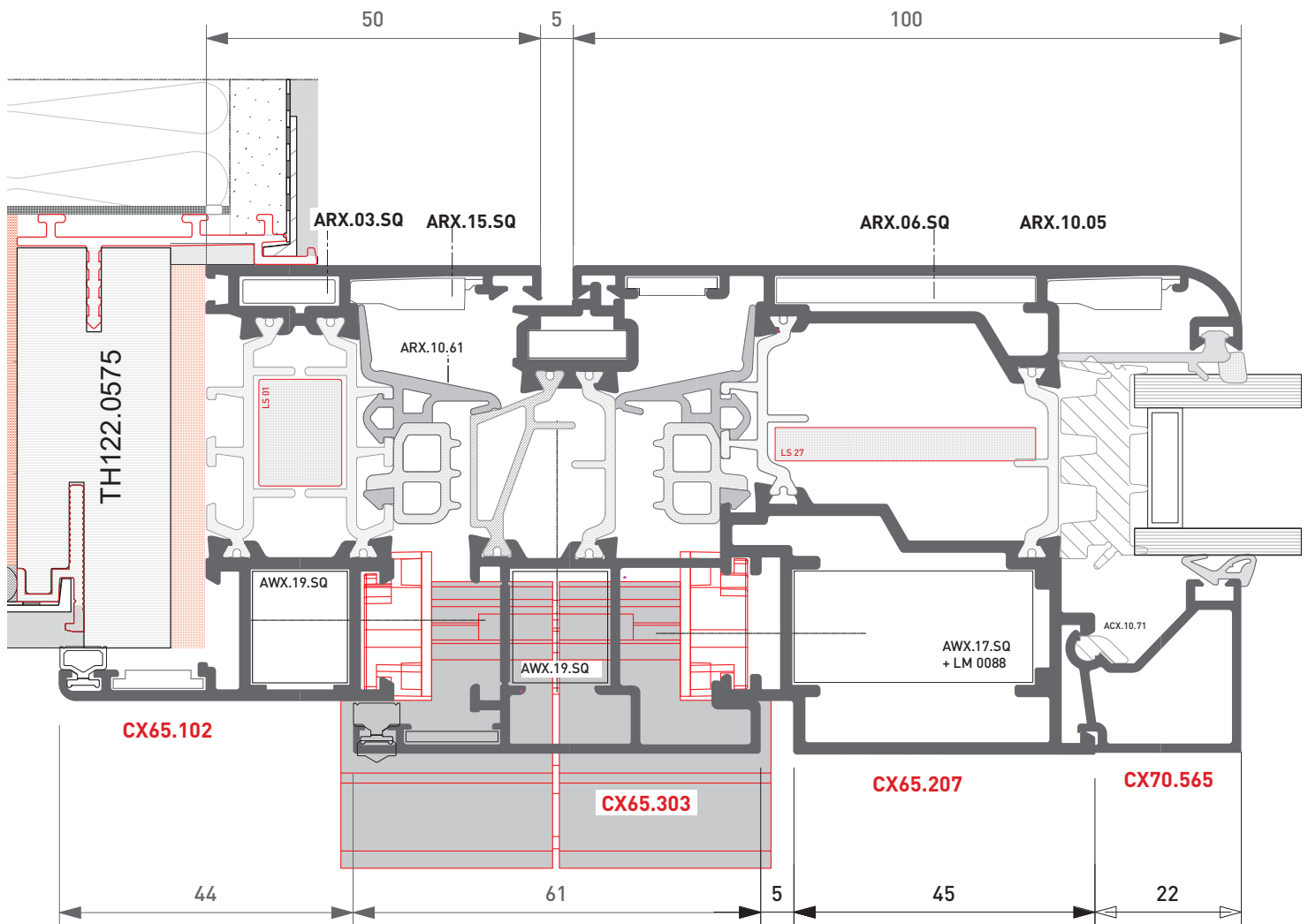
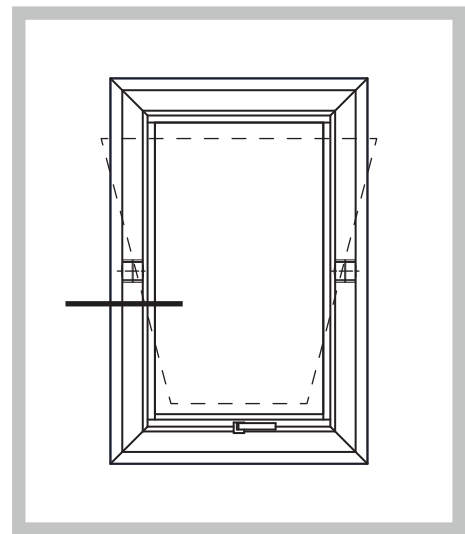



**FINESTRA
BILICO ORIZZONTALE**
*HORIZONTAL PIVOT
WINDOW*

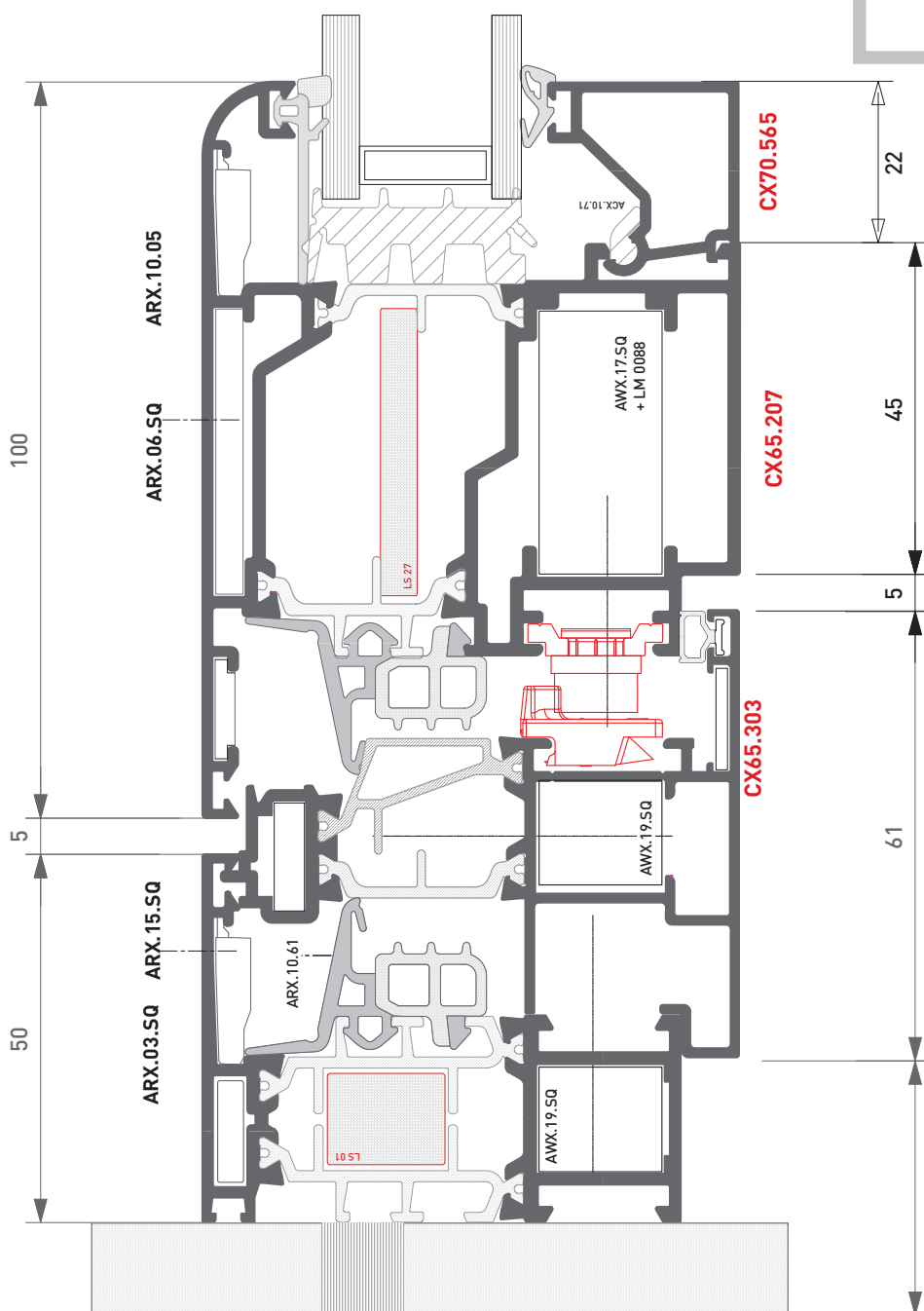
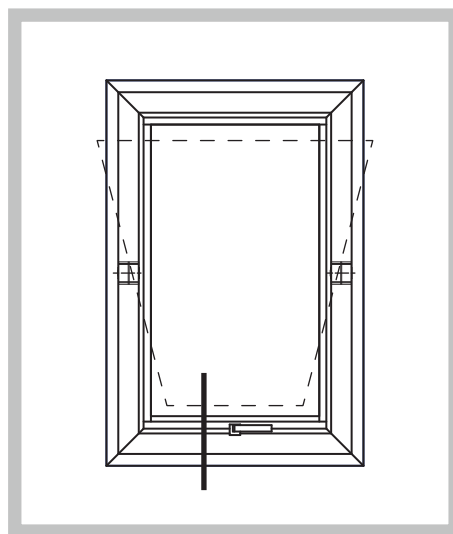



FINESTRA
BILICO ORIZZONTALE
HORIZONTAL PIVOT
WINDOW

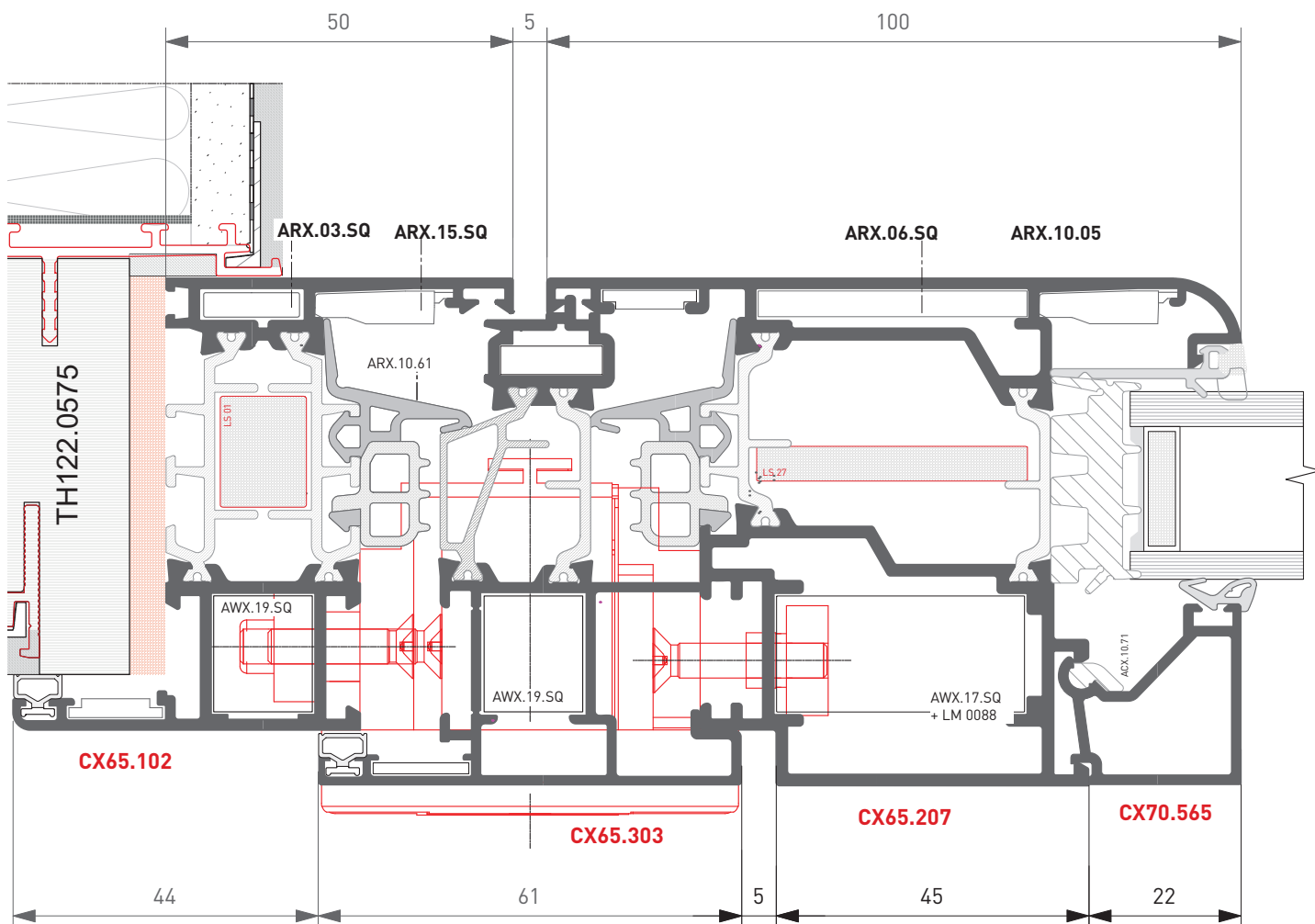
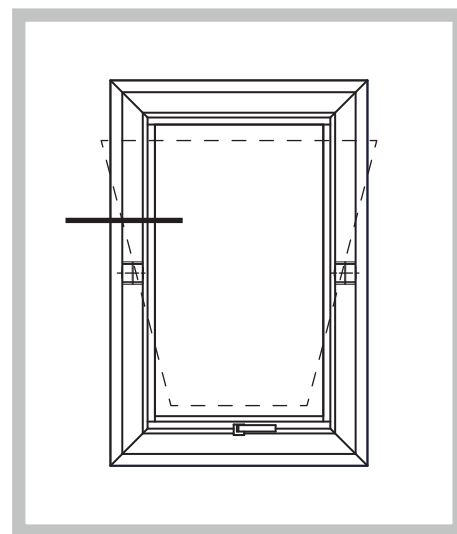

Accessorio Frizione **GU ITALIA U - 18/3**
Articolo 6 - 27212-07 - P
per accessori di movimentazione riferirsi
alla tavola di assieme
Friction Item GU ITALIA U - 88
Item 6 - 27212-07 - P
for movement accessories refer to overview table



ABBINAMENTO CON SCORREVOLE SX700
Telaio in appoggio
COMBINATION WITH SX700 SLIDING DOOR
On fixed frame

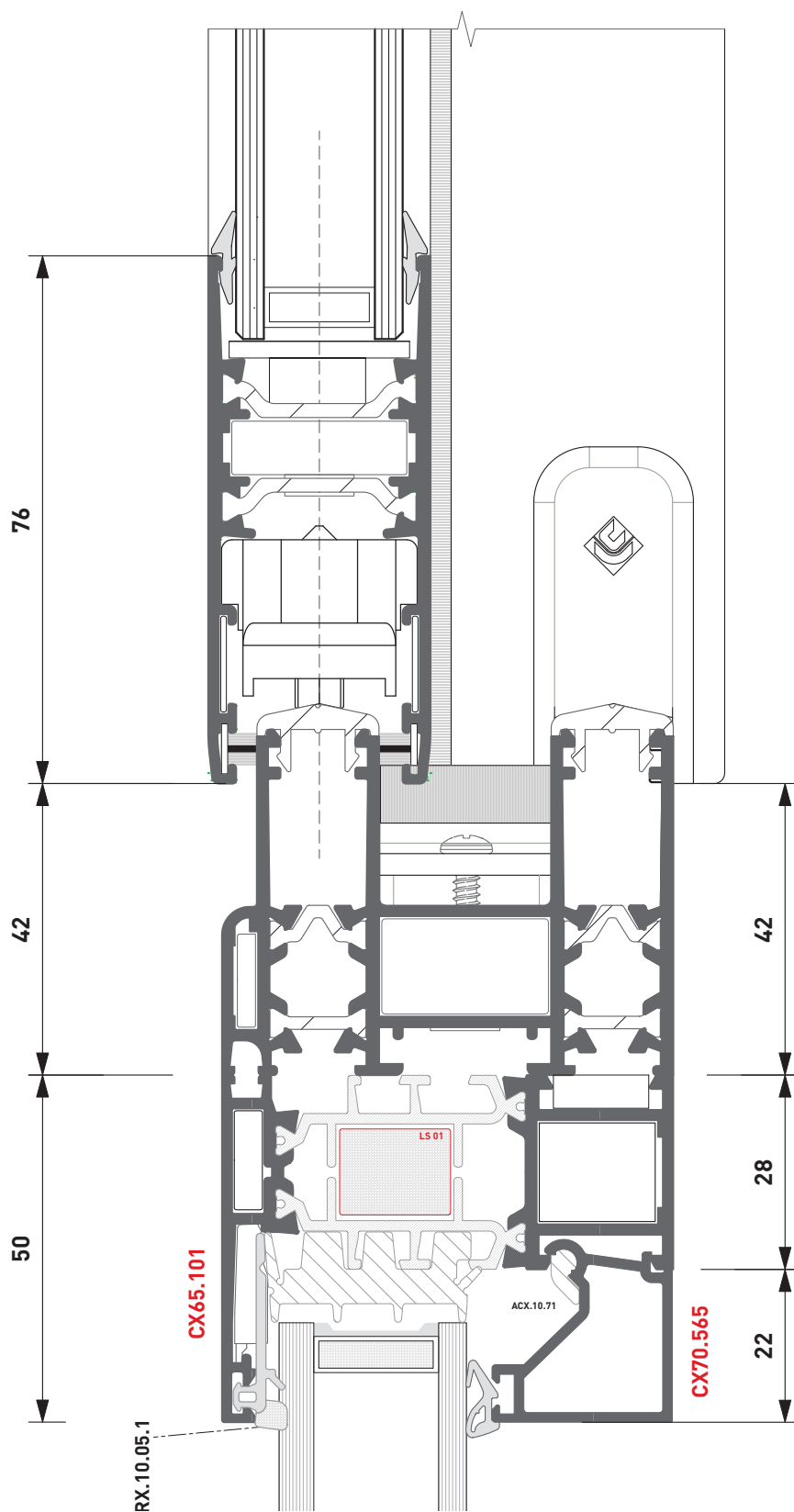
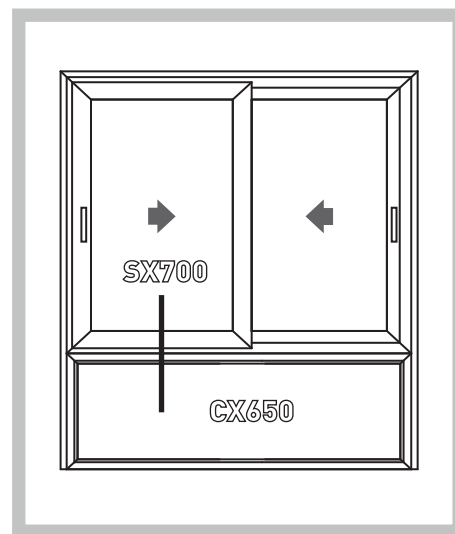

Per i riferimenti della serie SX 700
consultare il relativo catalogo.
Referer to SX 700 series catalog



**ABBINAMENTO CON SCORREVOLE SX85
CON TELAIO FISSO**
*COMBINATION WITH SX85 SLIDING DOOR
On fixed frame*

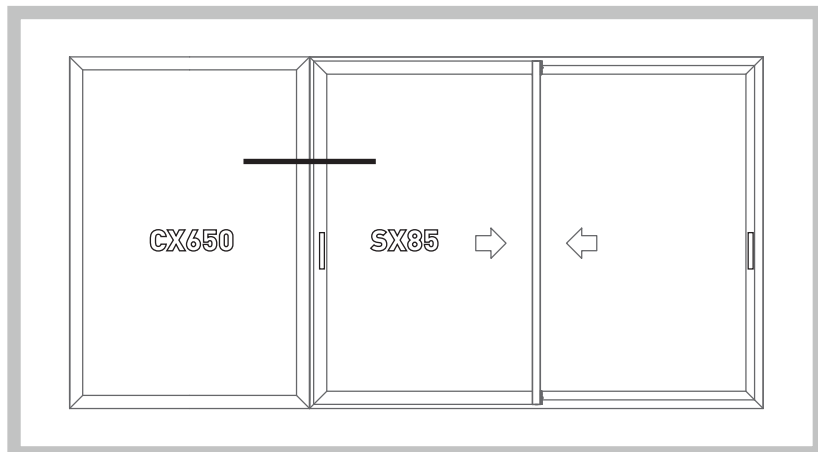

Profilo di accoppiamento SX85 e CX650
SX85 and CX650 System Coupling Profile

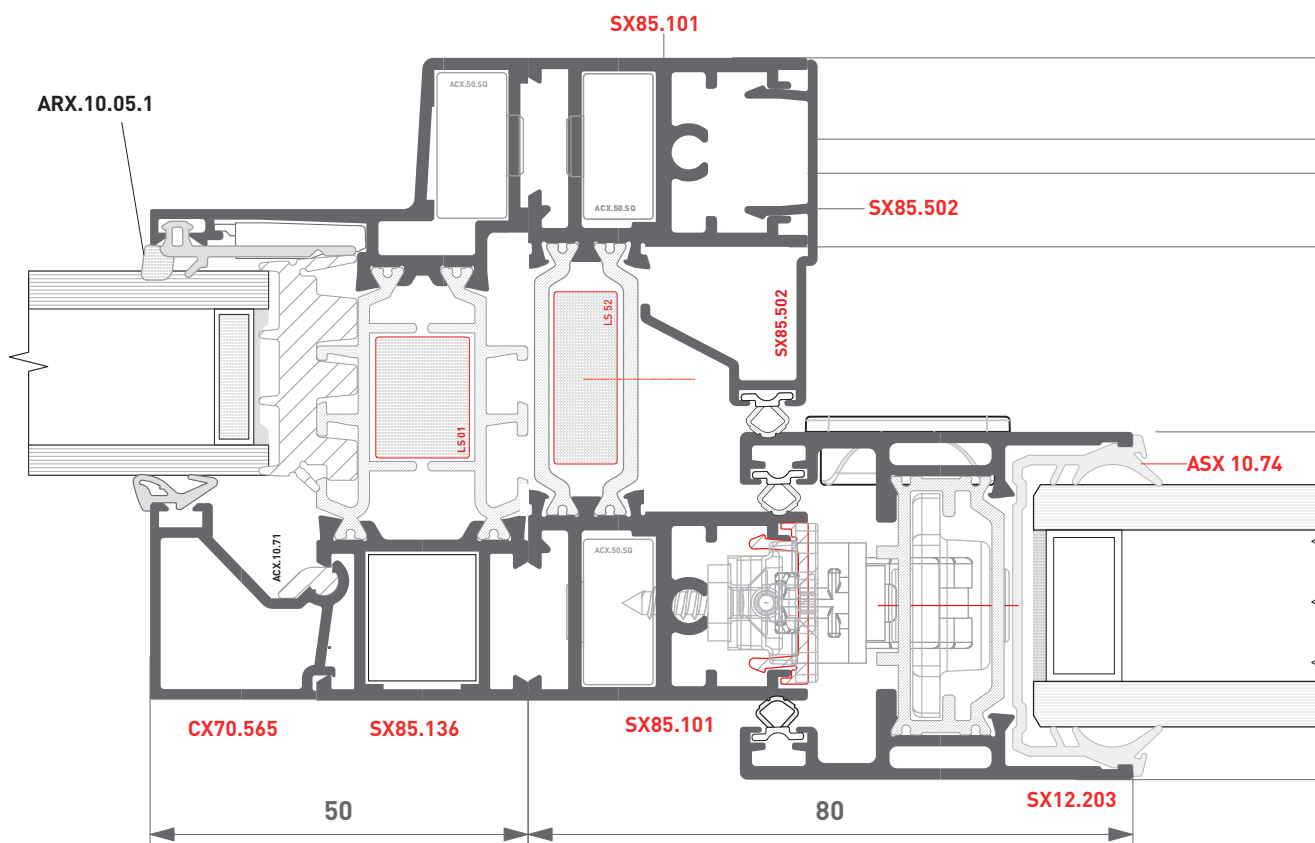

**Per i riferimenti della serie SX 85
consultare il relativo catalogo.**
Referer to SX 85 series catalog



TELAIO CAPANNONI | INDUSTRIAL SHED FRAME

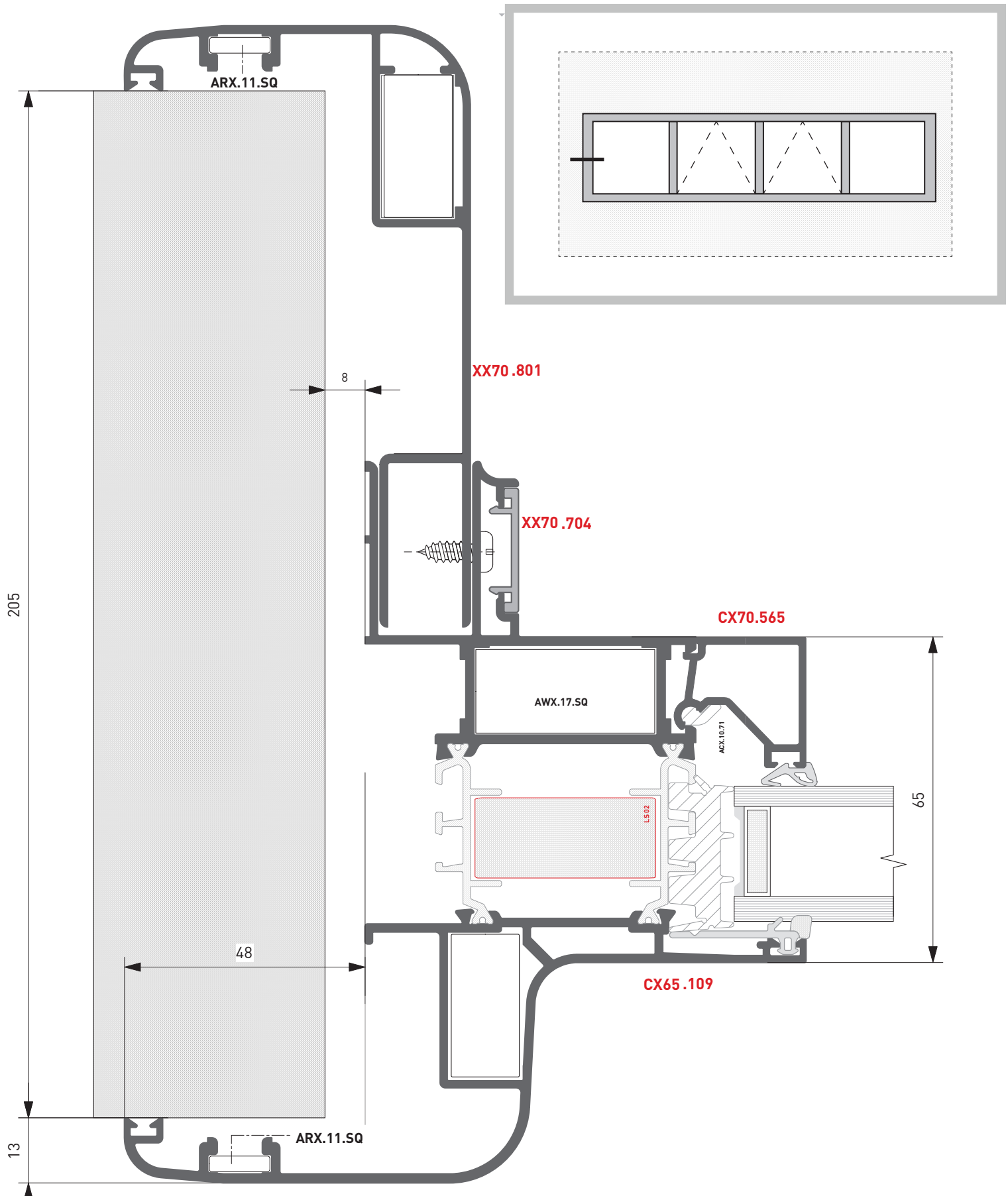



TELAIO CAPANNONI | INDUSTRIAL SHED FRAME

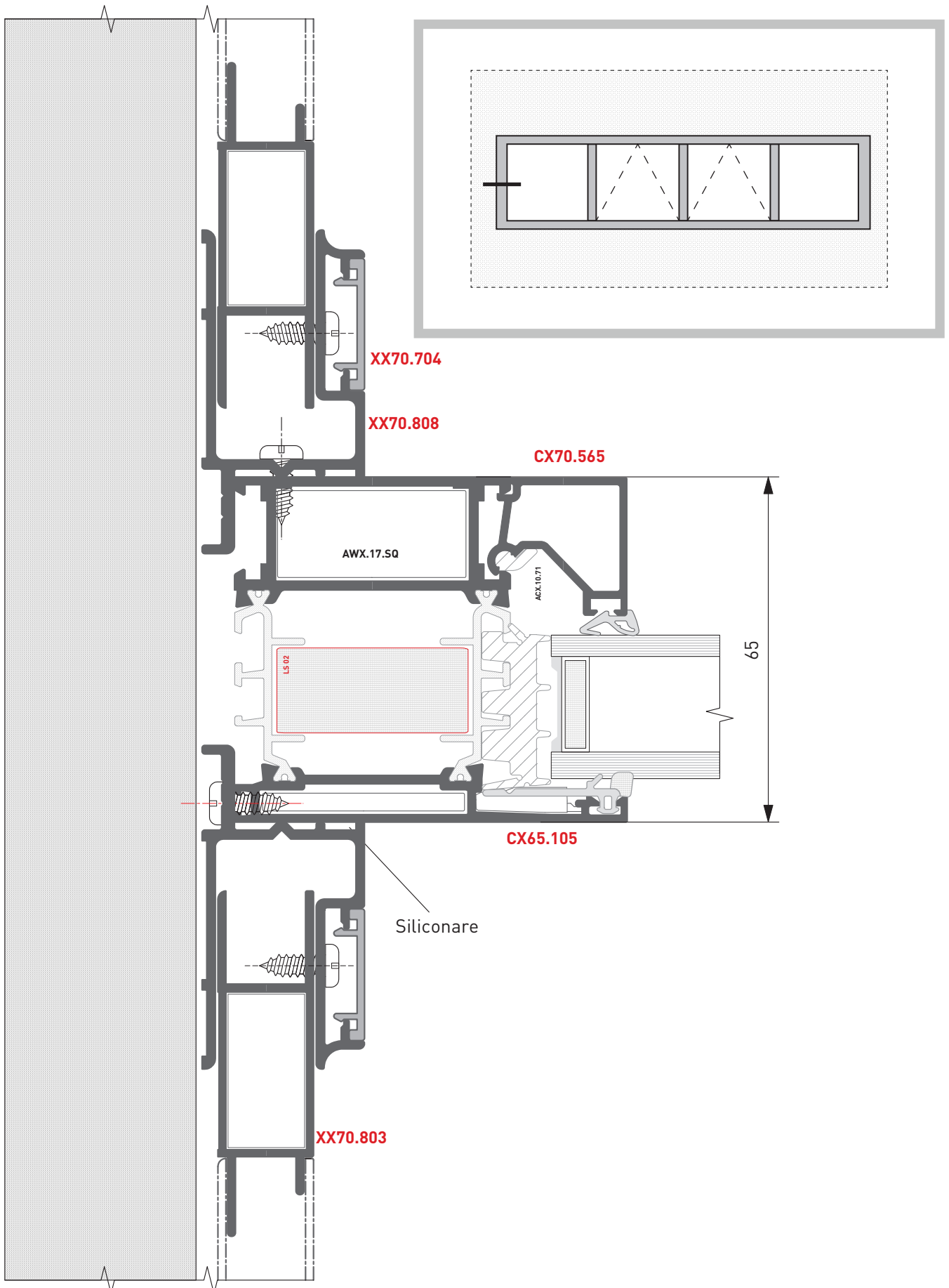



TELAI COMPENSAZIONE
LEVELLING FRAME

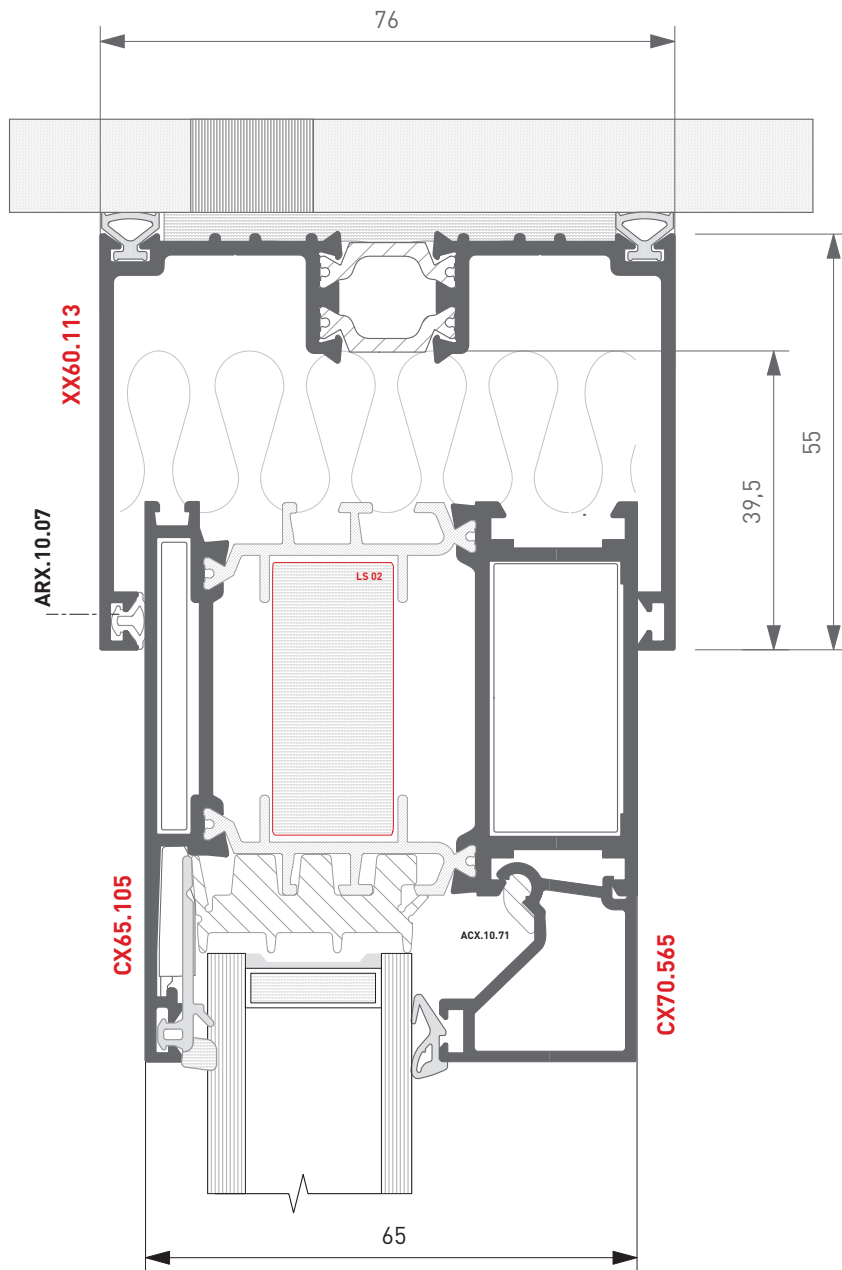
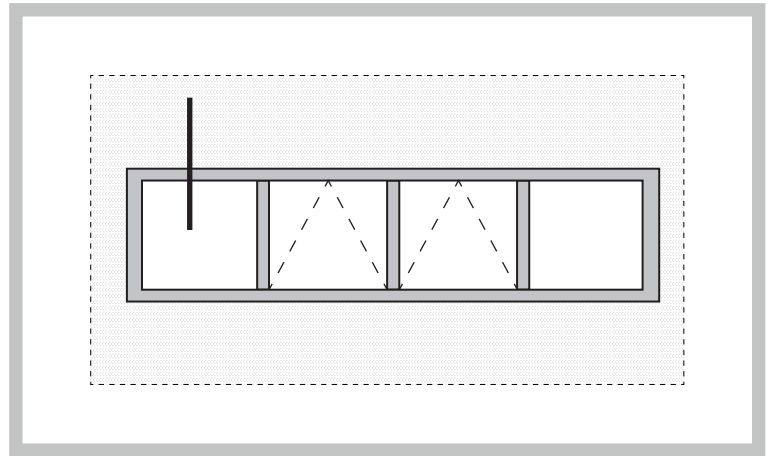



Profilo Battuta Capannone Shed Stop Profile

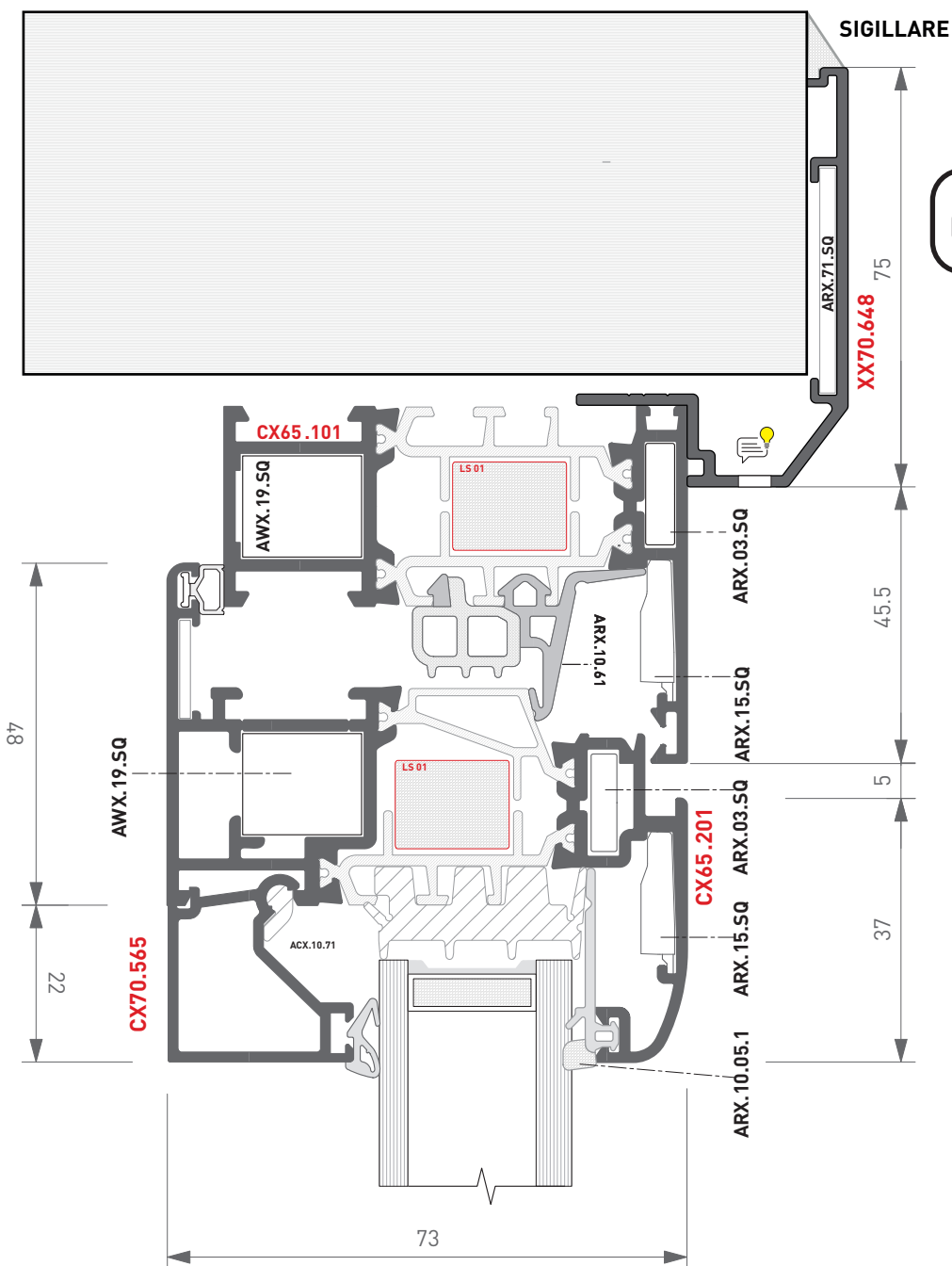
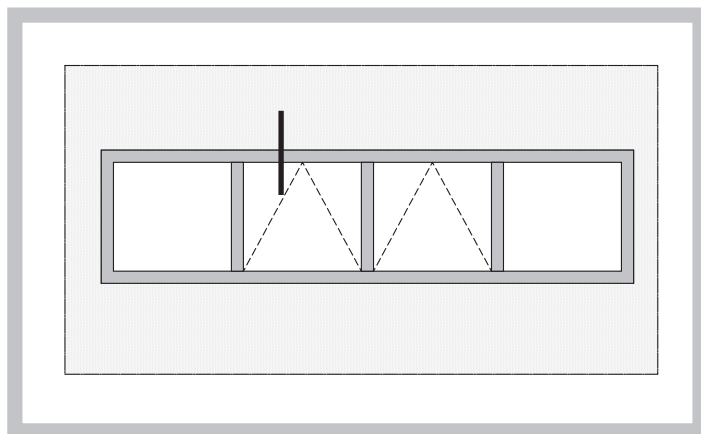

■ Asola scarico acqua
water drainage hole



PROFILO UNIVERSALE PER ANGOLO A 90°
UNIVERSAL PROFILE FOR 90° CORNER

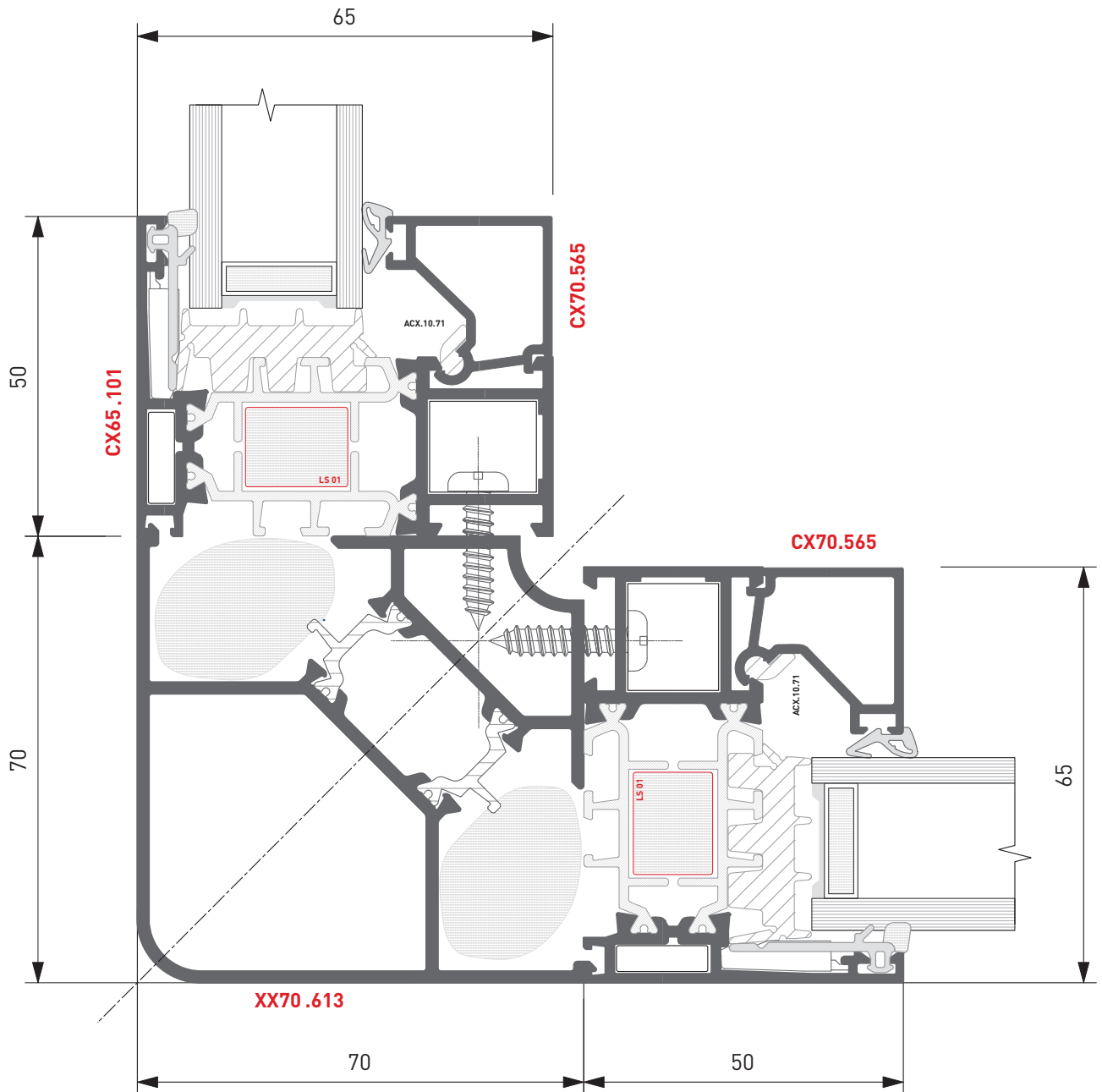



PORTA DI INGRESSO A 2 ANTE
APERTURA INTERNA
DOUBLE SASH ENTRANCE DOOR
OPEN INSIDE

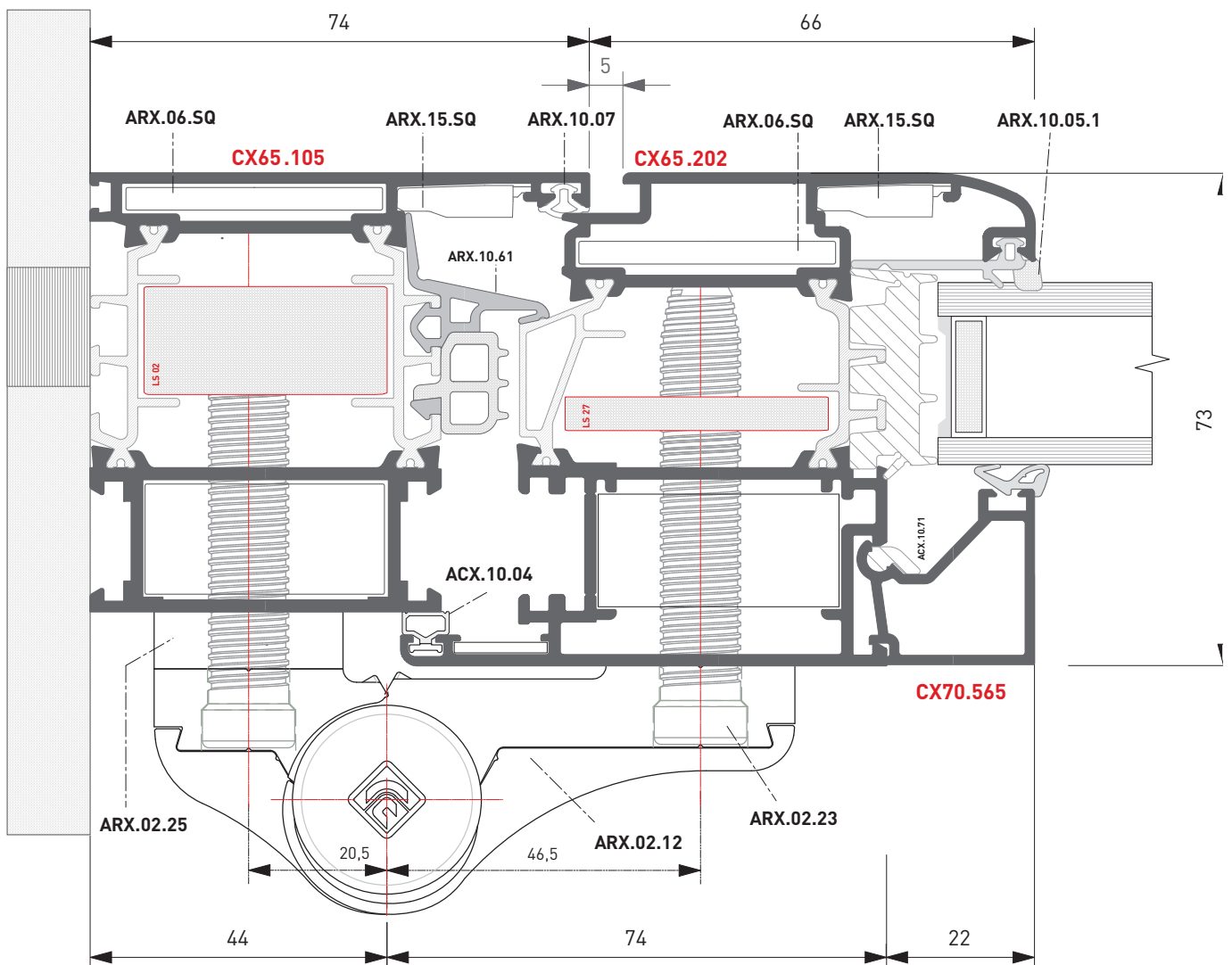
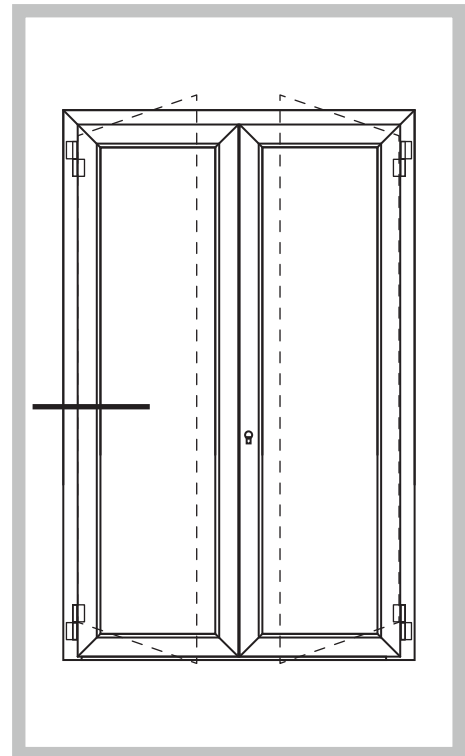



PORTA DI INGRESSO A 2 ANTE
APERTURA INTERNA
DOUBLE SASH ENTRANCE DOOR
OPEN INSIDE

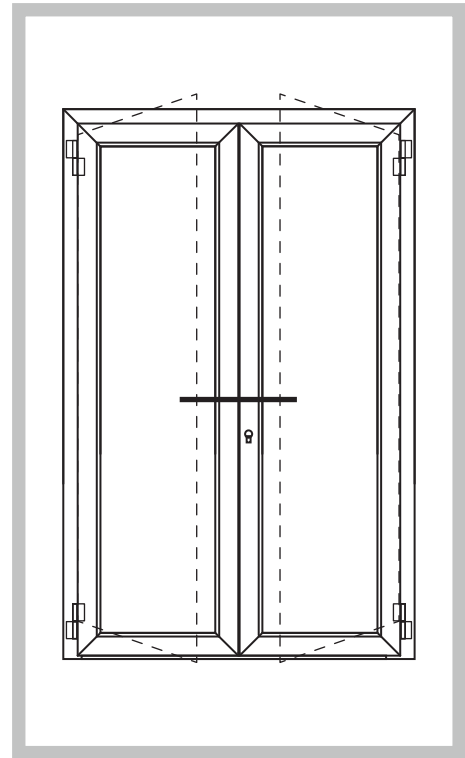
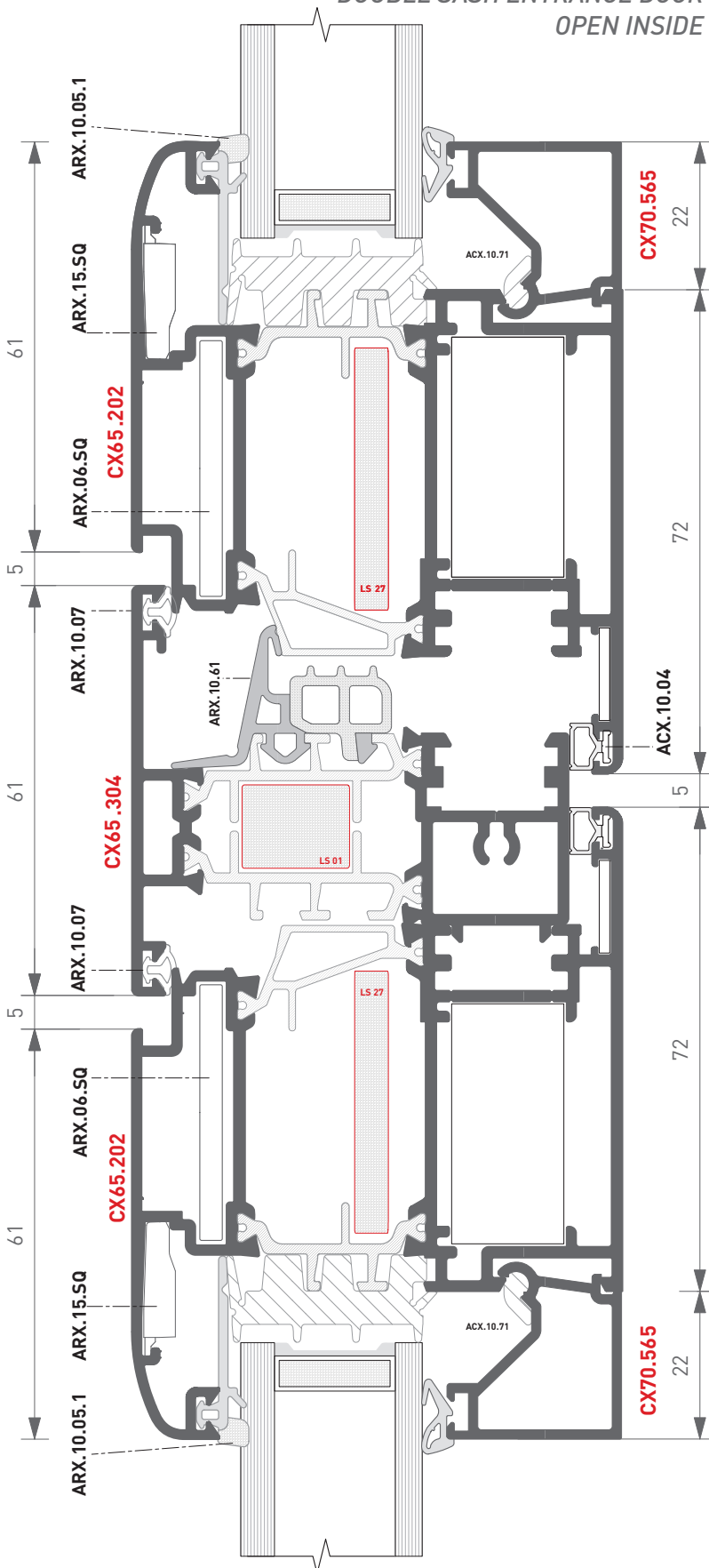



PORTA DI INGRESSO AD UNA ANTA
APERTURA INTERNA
SINGLE SASH ENTRANCE DOOR
OPEN INSIDE

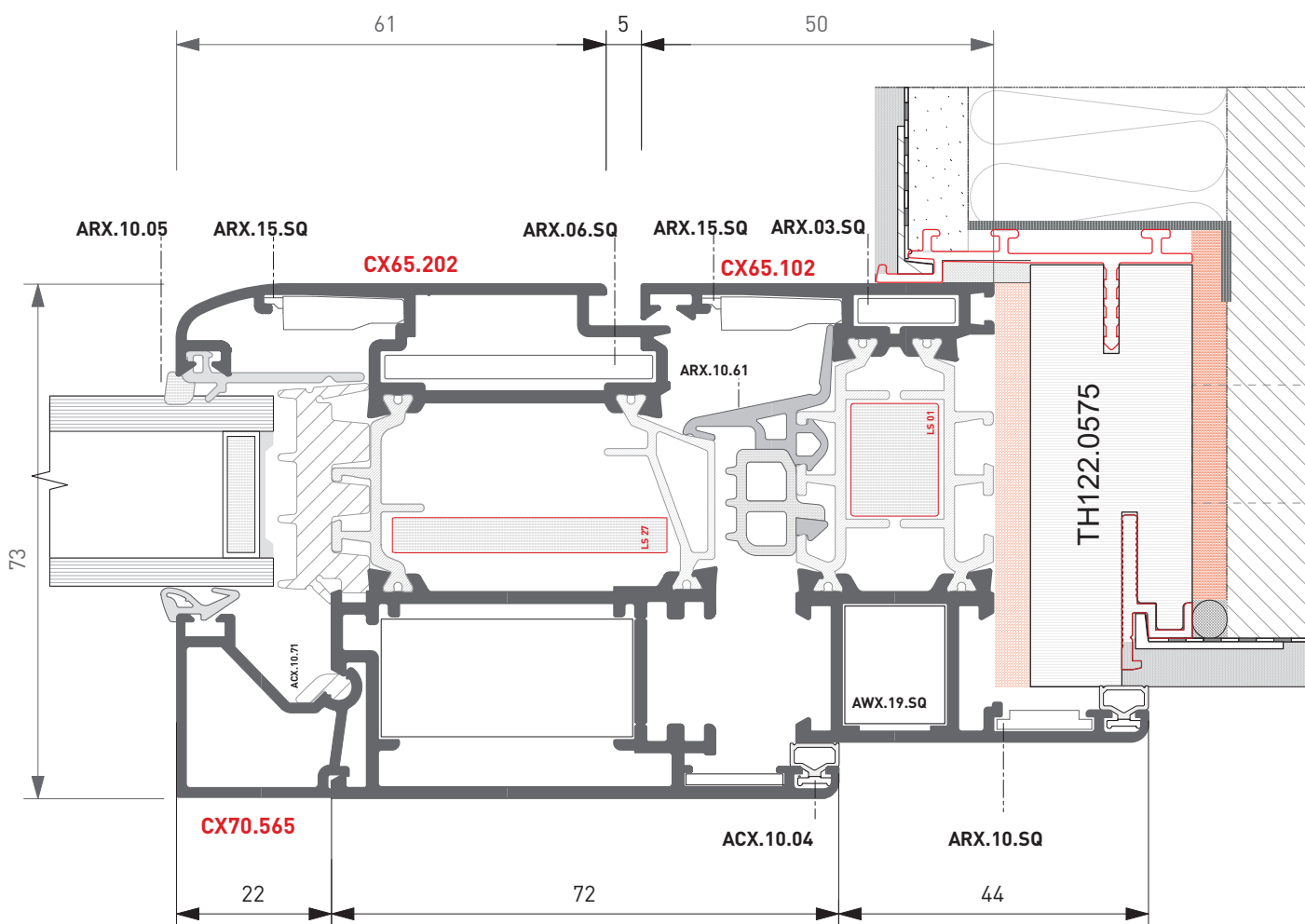
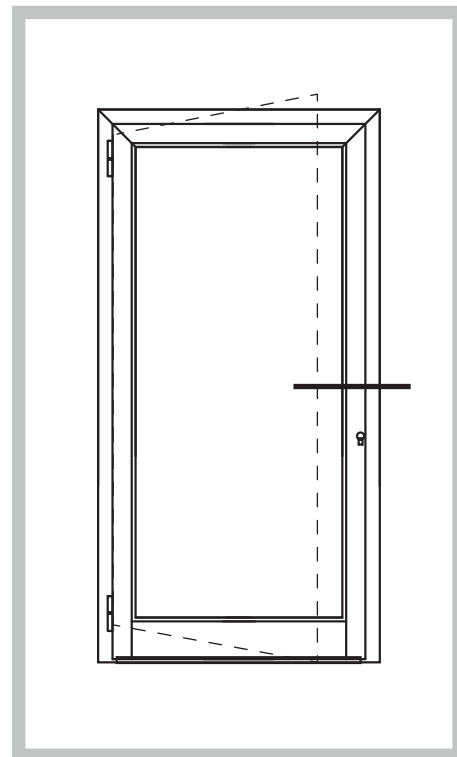



PORTA DI INGRESSO A 2 ANTE
APERTURA ESTERNA
SOLUZIONE CON SPAZZOLINO
DOUBLE SASH ENTRANCE DOOR
OPEN OUTSIDE SOLUTION WITH BRUSH

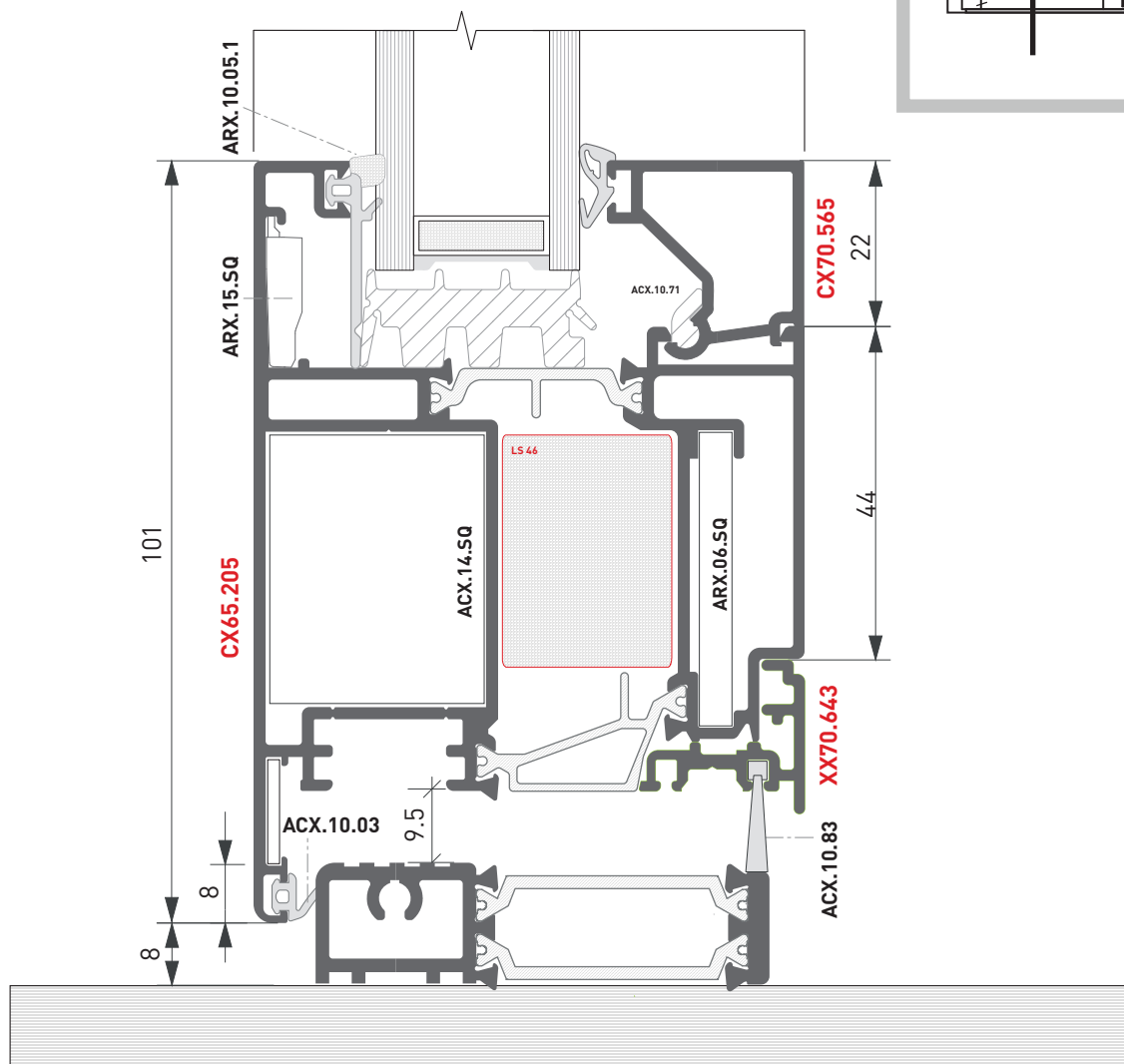
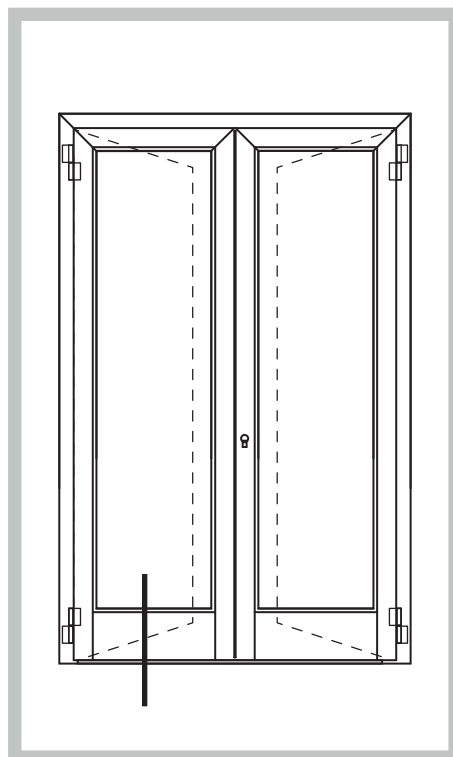



PORTA DI INGRESSO A 2 ANTE
APERTURA INTERNA CON GUARNIZIONE
DOUBLE SASH ENTRANCE DOOR
OPEN INSIDE WITH GASKET

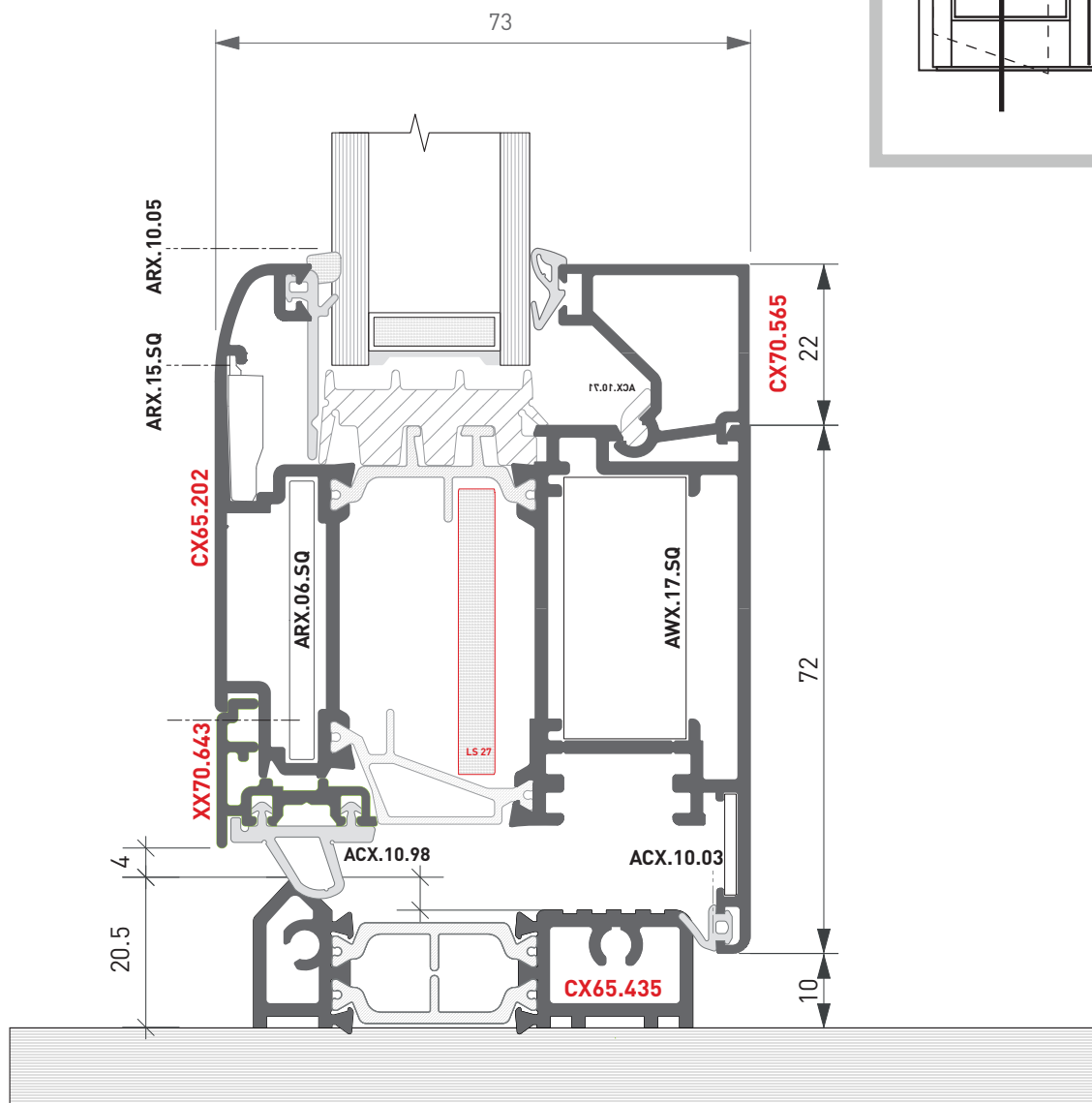
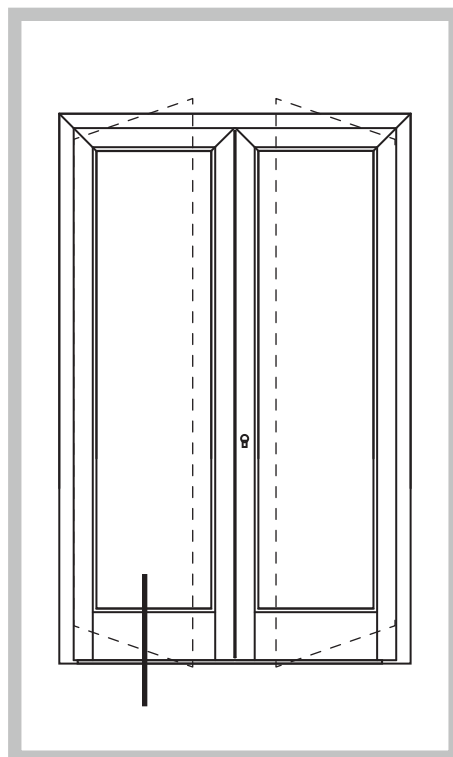



PORTA DI INGRESSO A 2 ANTE
APERTURA INTERNA
DOUBLE SASH ENTRANCE DOOR
OPEN INSIDE

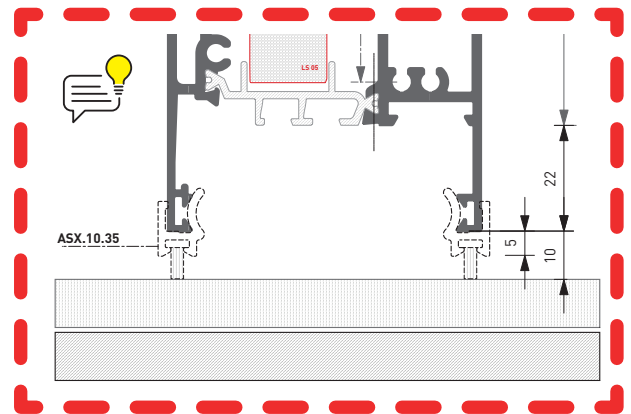
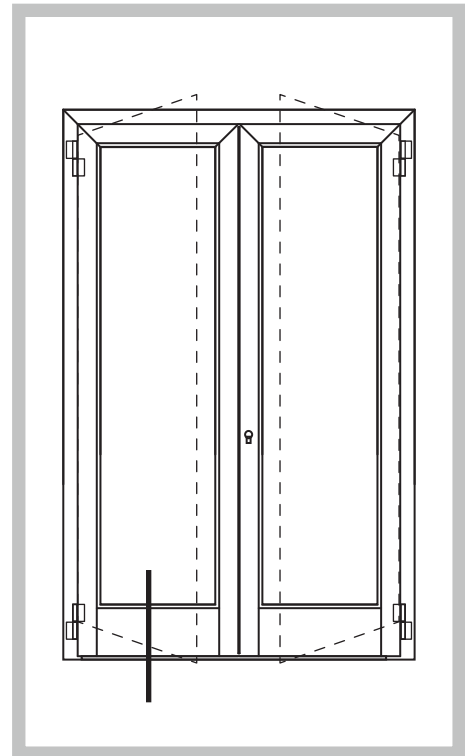
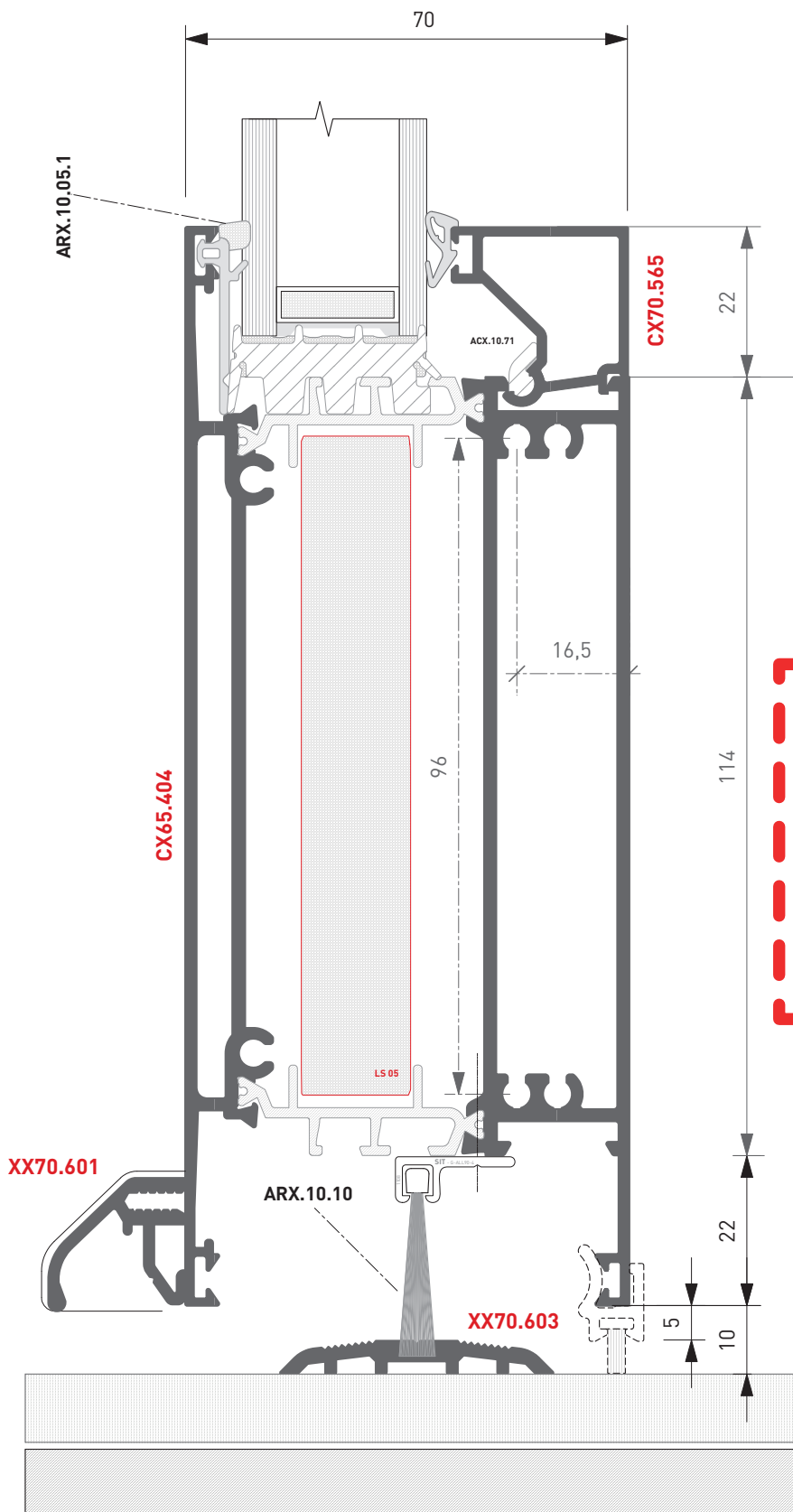

■ Variante con doppio articolo ASX.10.35 e spazzolino 4,8x10mm
Version with double item ASX.10.35 and brush 4.8x10mm

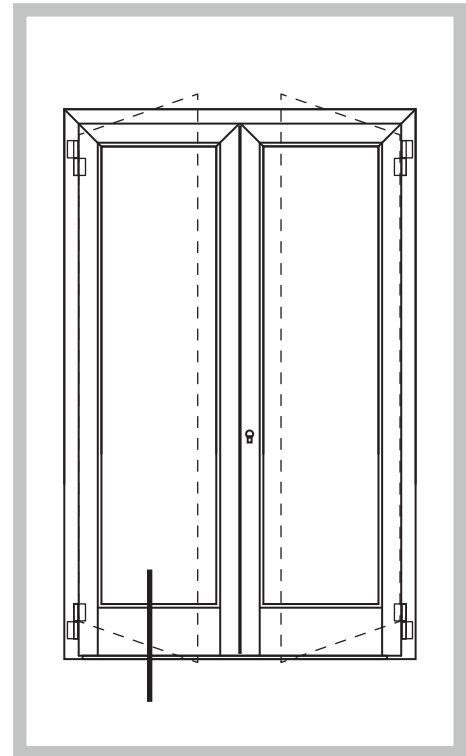
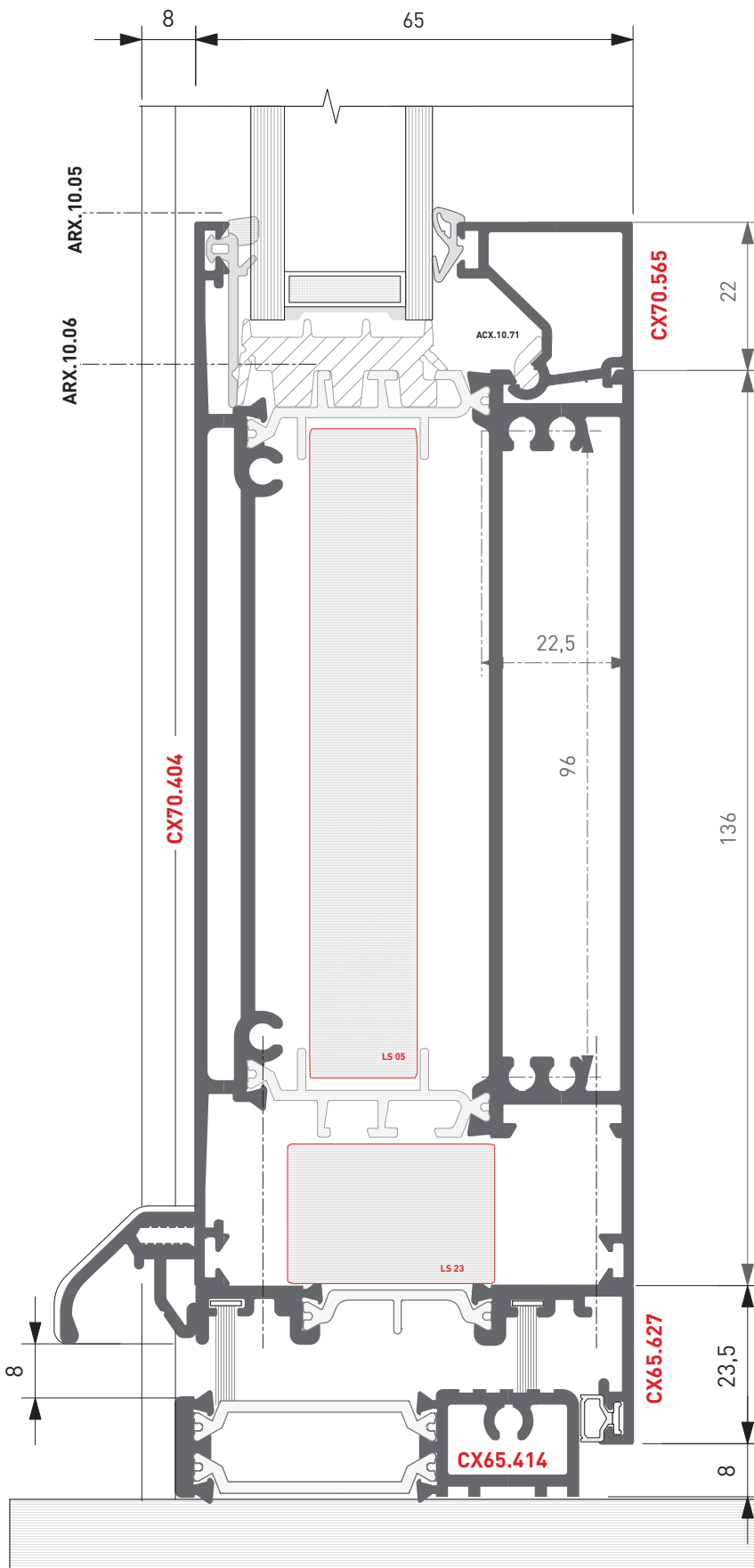

PORTA DI INGRESSO A 2 ANTE
APERTURA INTERNA
DOUBLE SASH ENTRANCE DOOR
OPEN INSIDE

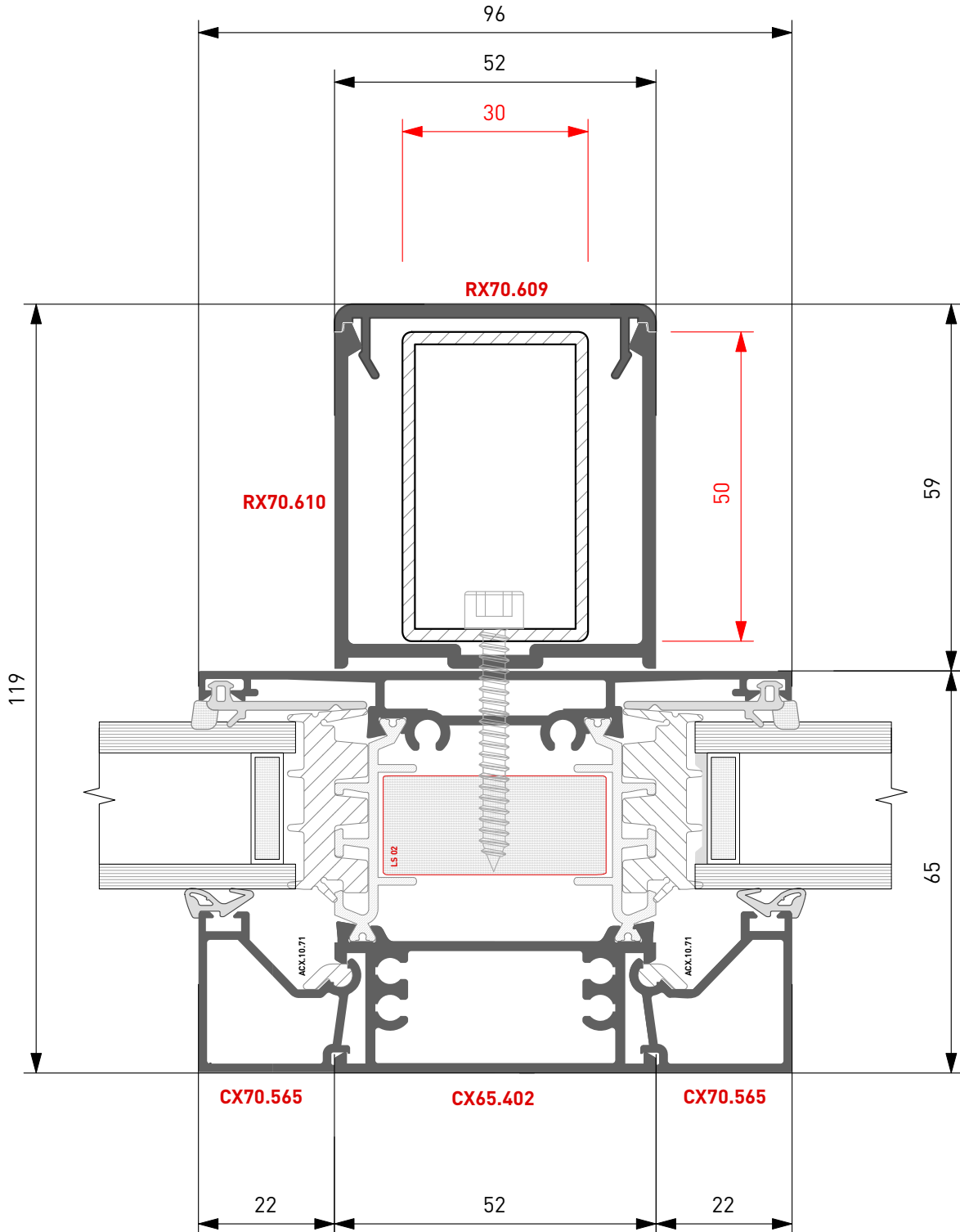

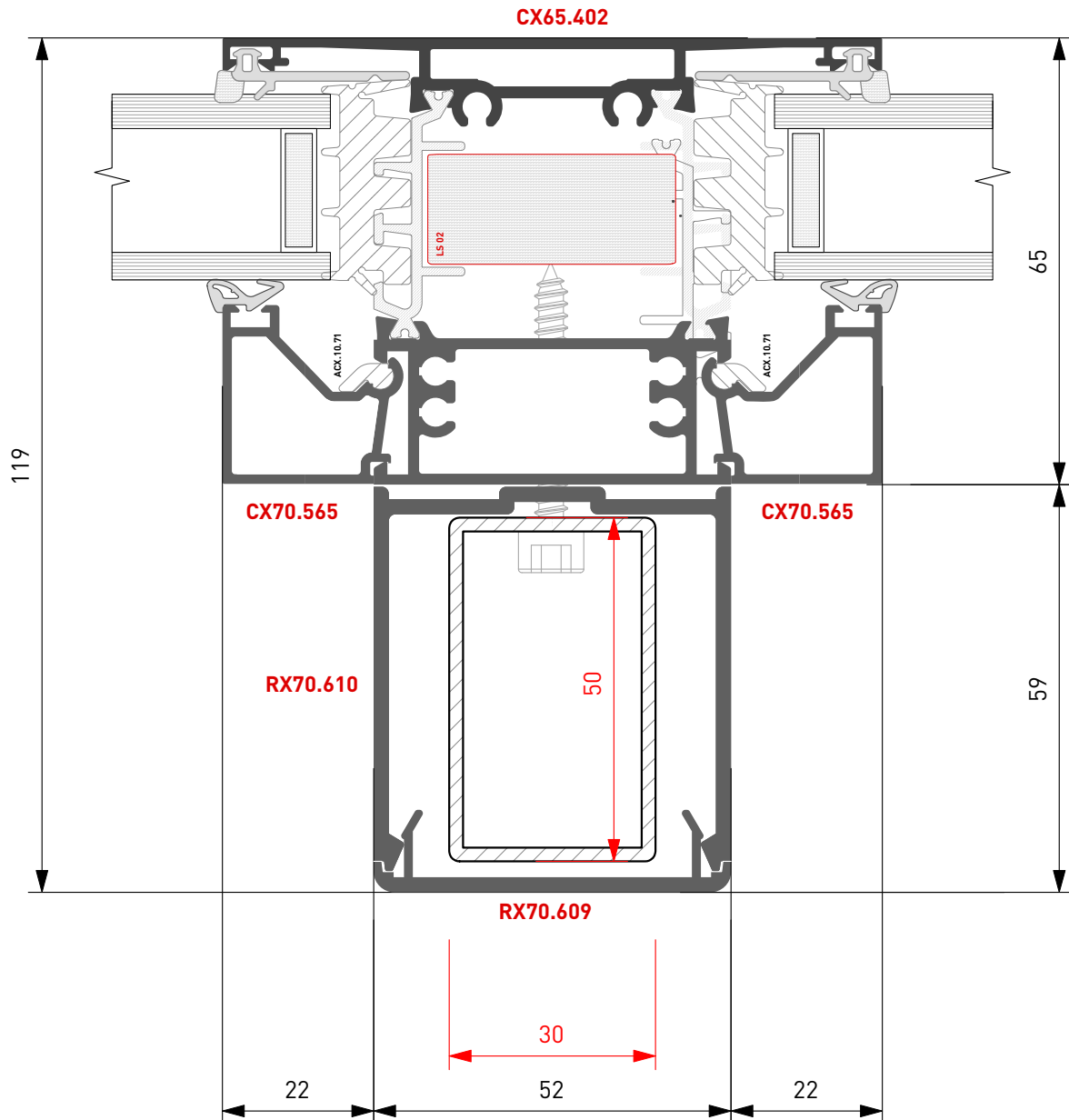

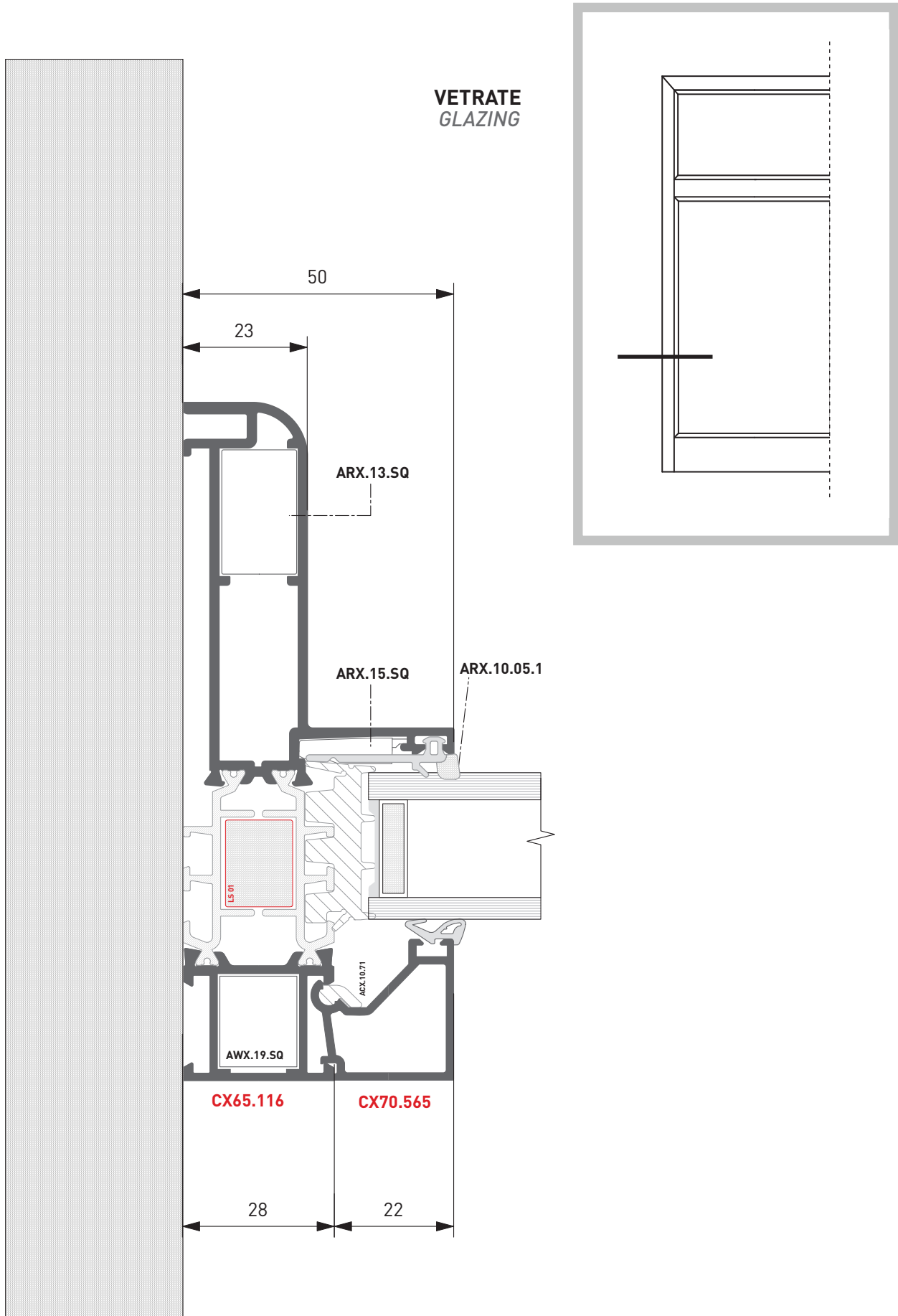



VETRATE
GLAZING

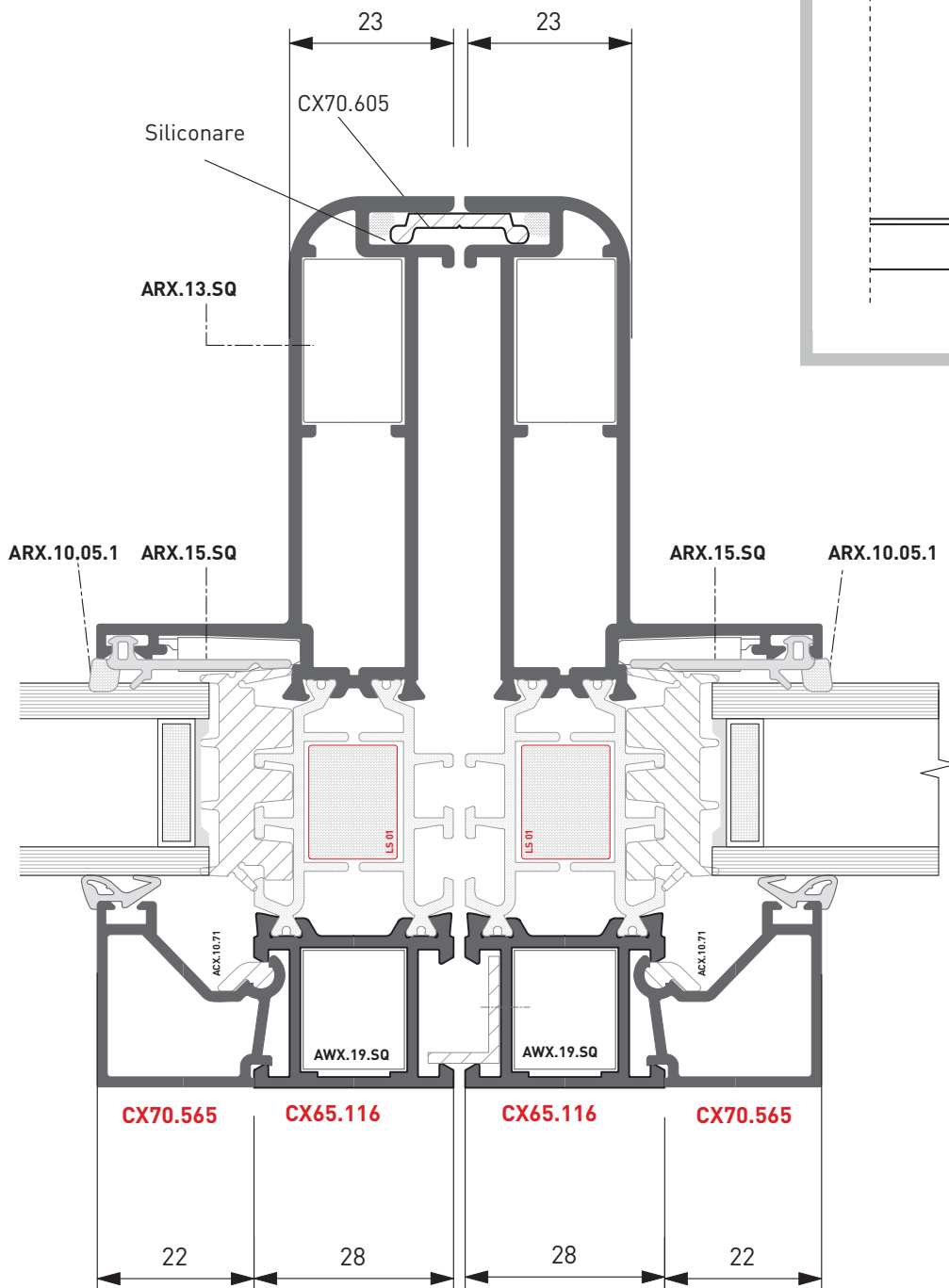
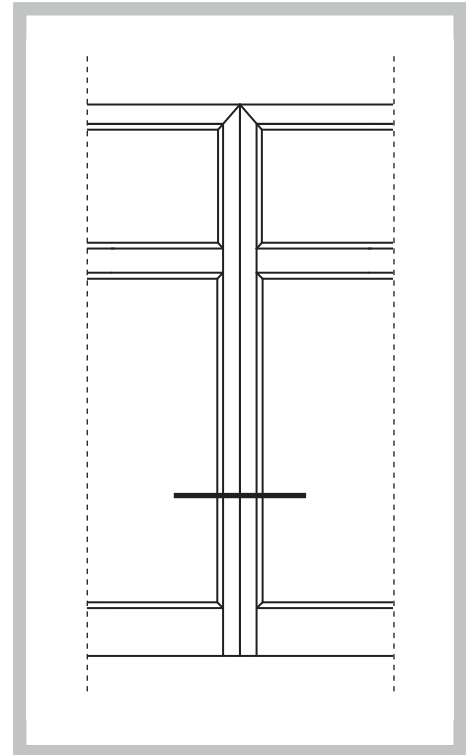



PORTA DI INGRESSO A 2 ANTE
APERTURA ESTERNA
DOUBLE SASH ENTRANCE DOOR
OPEN OUTSIDE

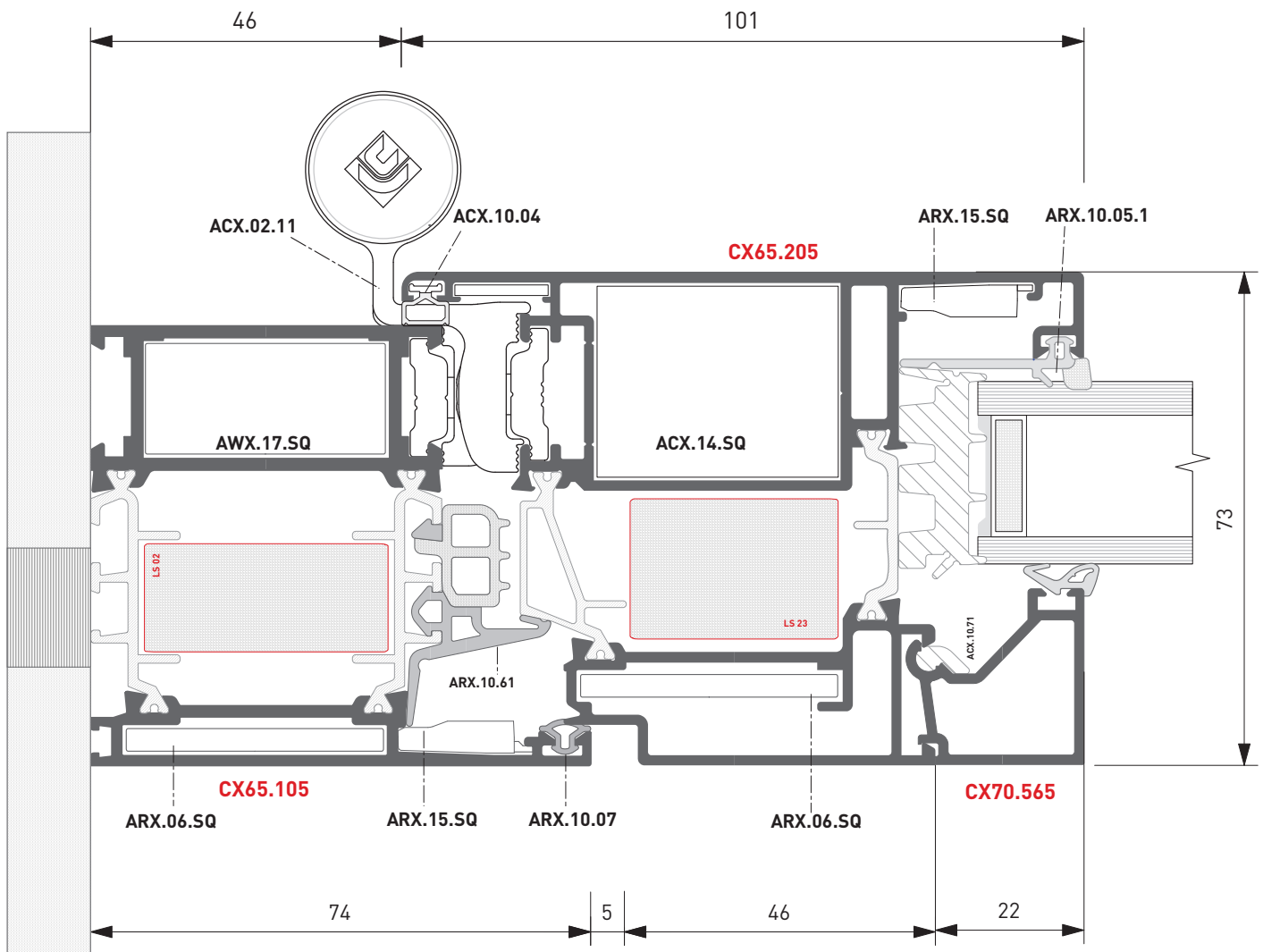
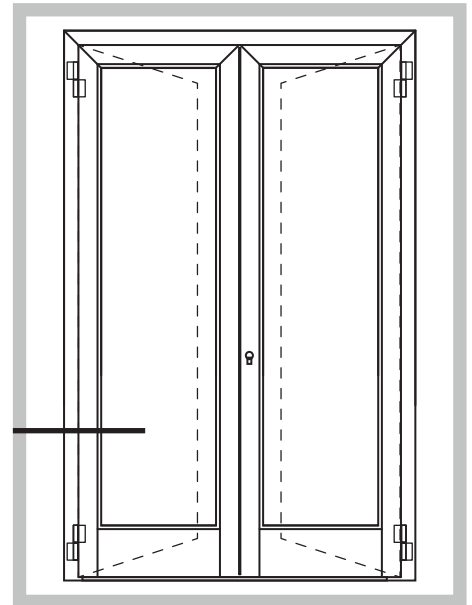



PORTA DI INGRESSO A 2 ANTE
APERTURA ESTERNA
DOUBLE SASH ENTRANCE DOOR
OPEN OUTSIDE

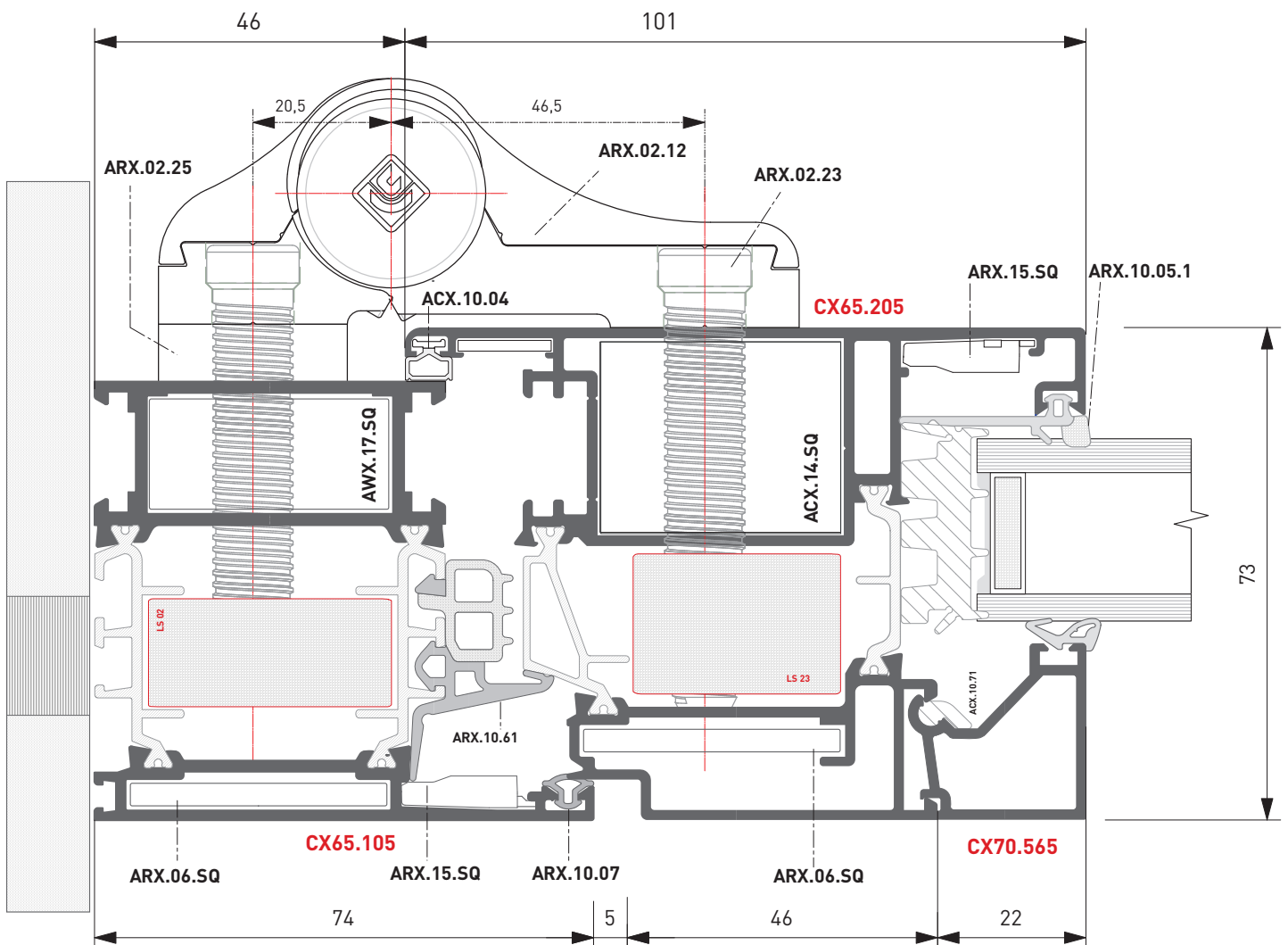
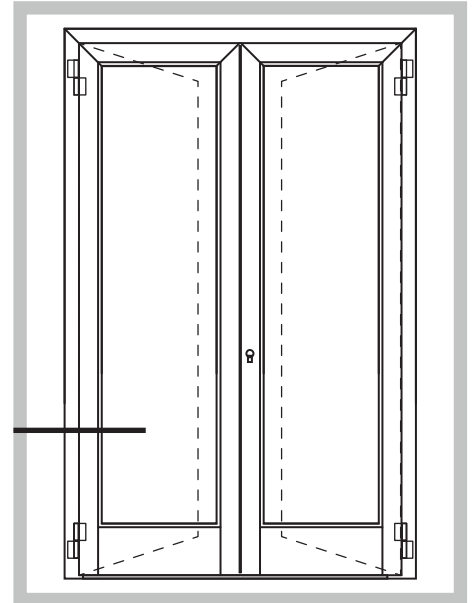



PORTA DI INGRESSO A 2 ANTE
APERTURA ESTERNA
DOUBLE SASH ENTRANCE DOOR
OPEN OUTSIDE

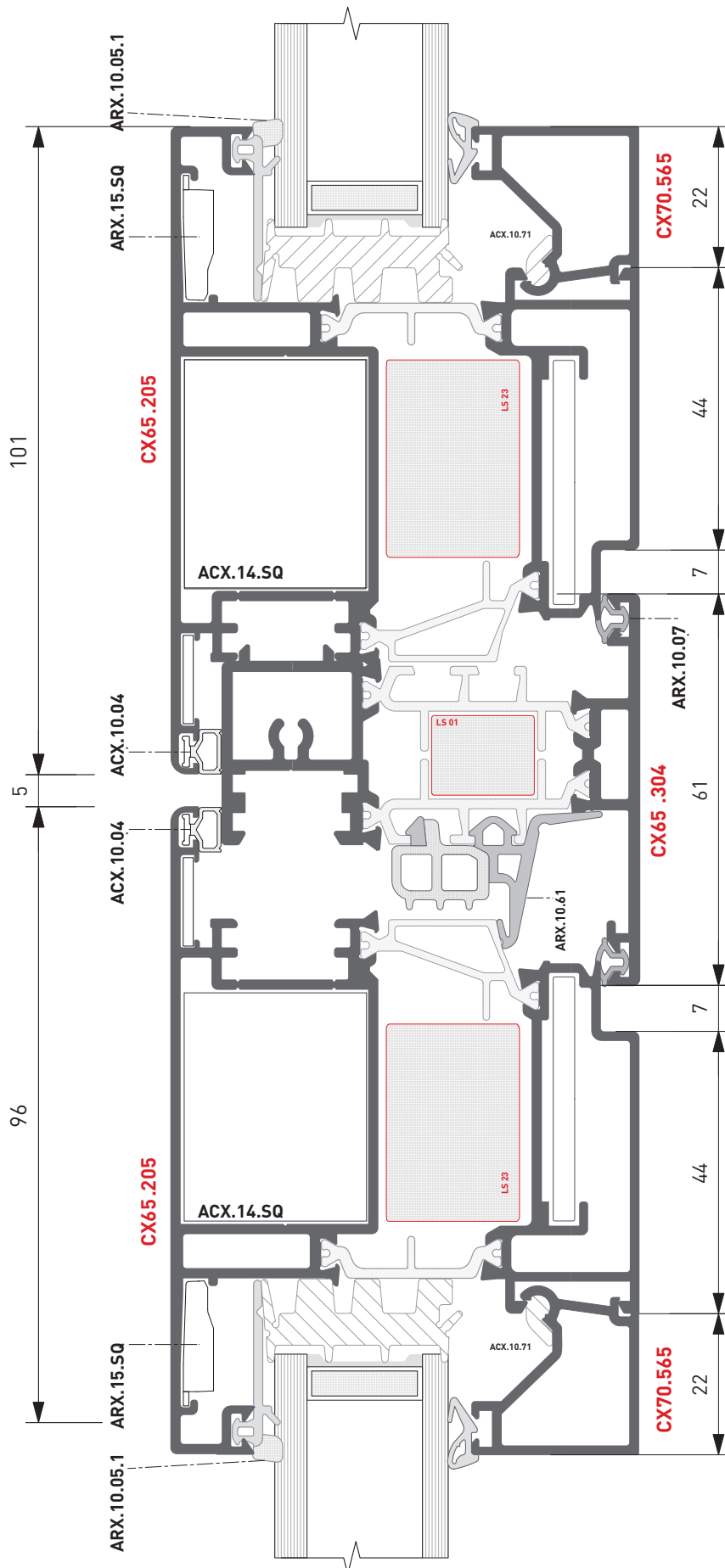
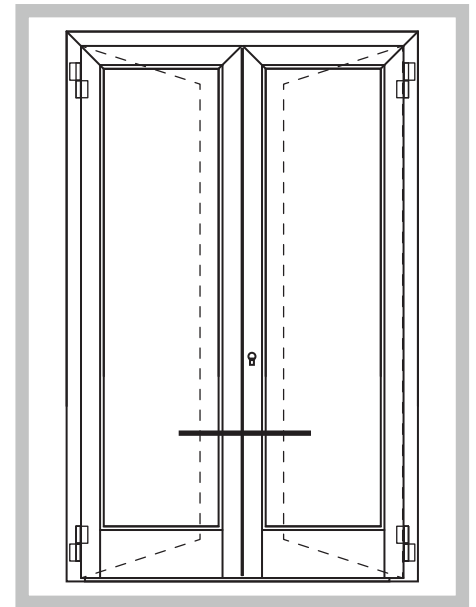



PORTA DI INGRESSO A 3 ANTE
APERTURA ESTERNA
3 SASHES ENTRANCE DOOR
OPEN OUTSIDE

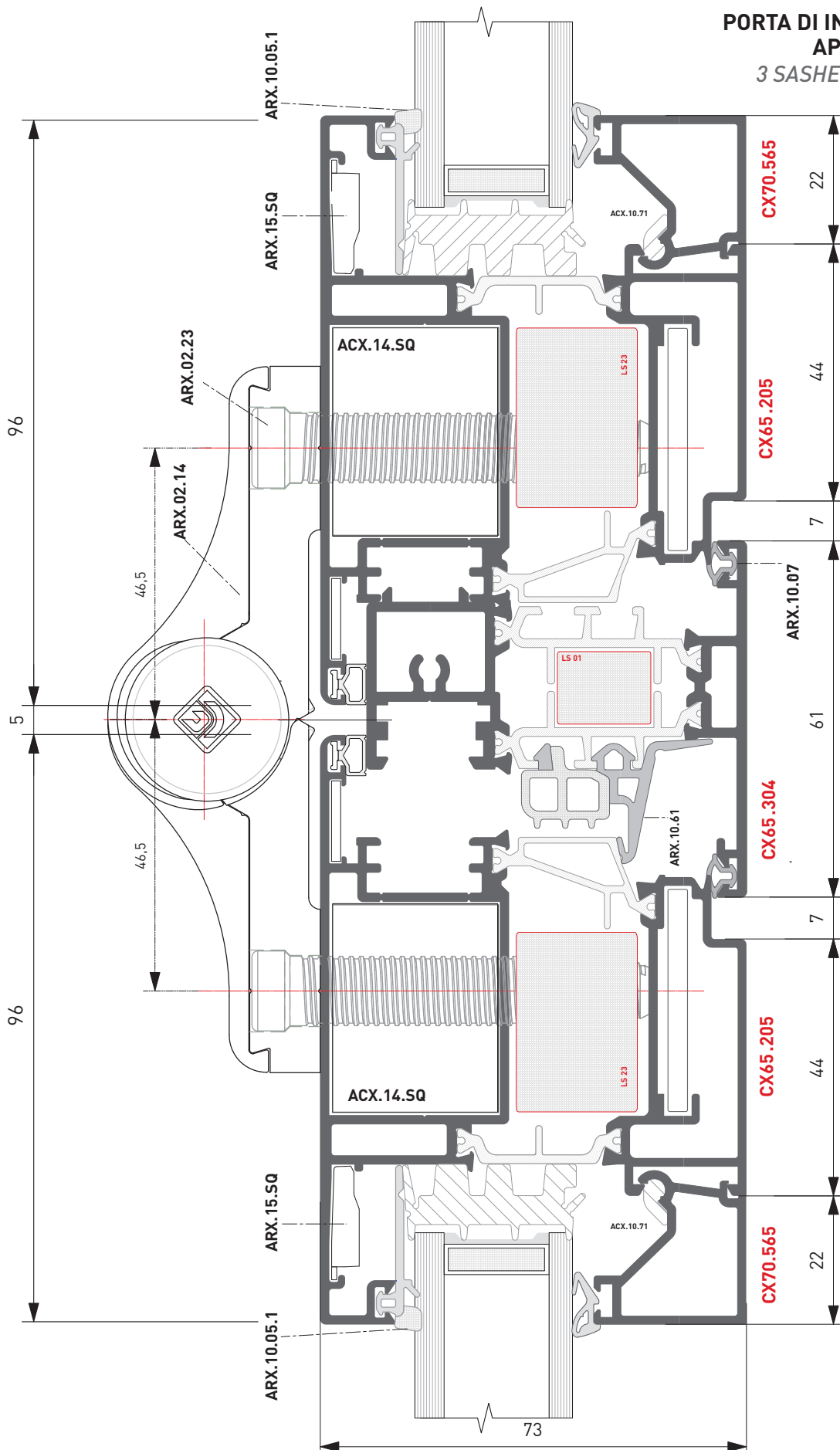



PORTA DI INGRESSO AD UNA ANTA
APERTURA ESTERNA
SINGLE SASH ENTRANCE DOOR
OPEN OUTSIDE

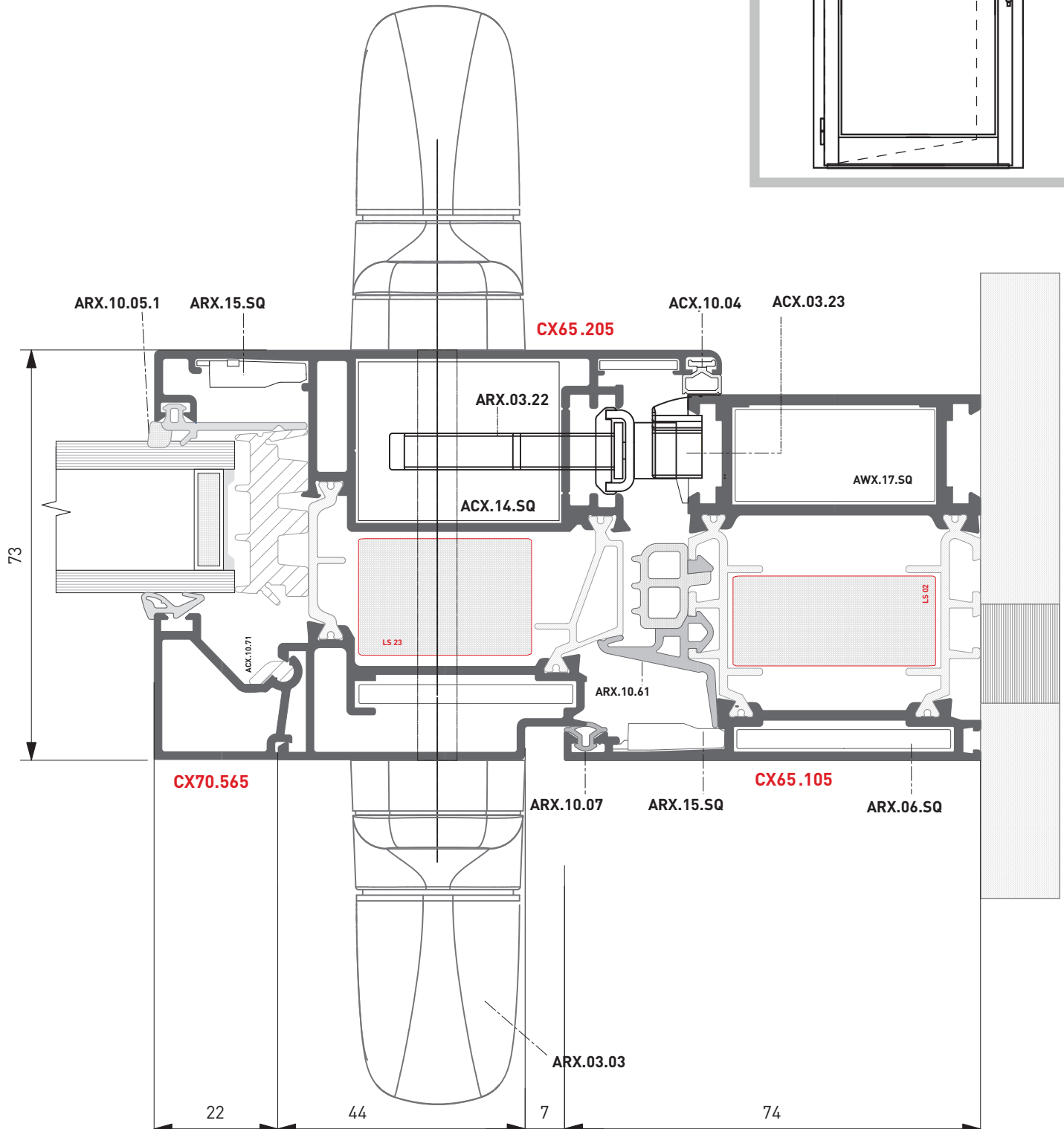
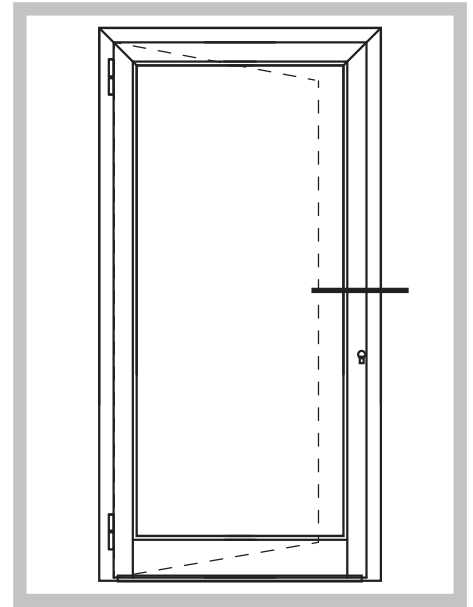



PORTA DI INGRESSO A 2 ANTE
APERTURA INTERNA
DOUBLE SASH ENTRANCE DOOR
OPEN INSIDE

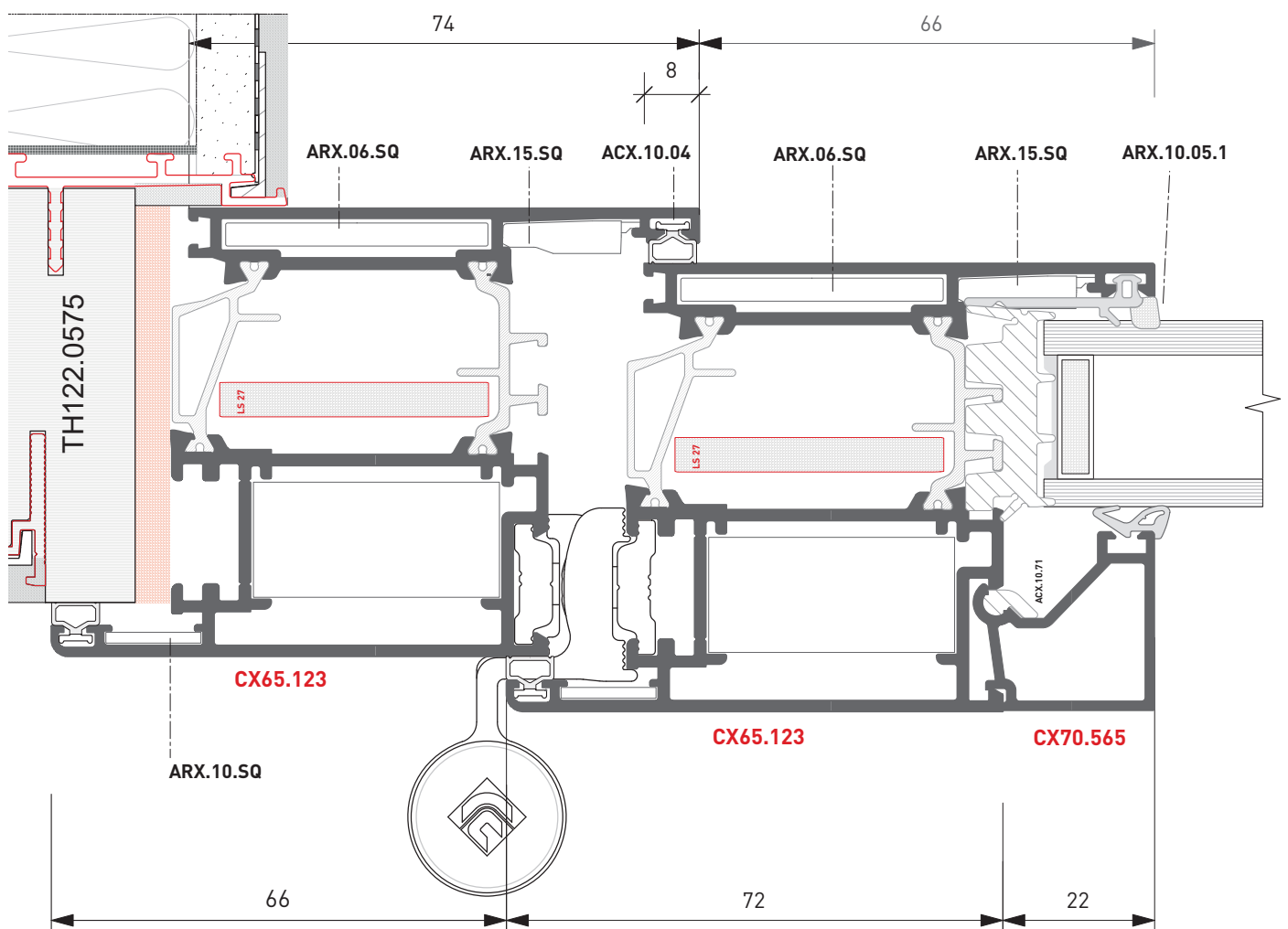
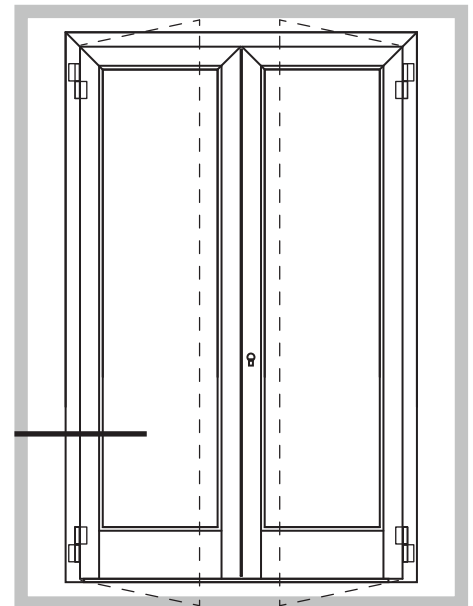



PORTA DI INGRESSO A 2 ANTE
APERTURA INTERNA
DOUBLE SASH ENTRANCE DOOR
OPEN INSIDE

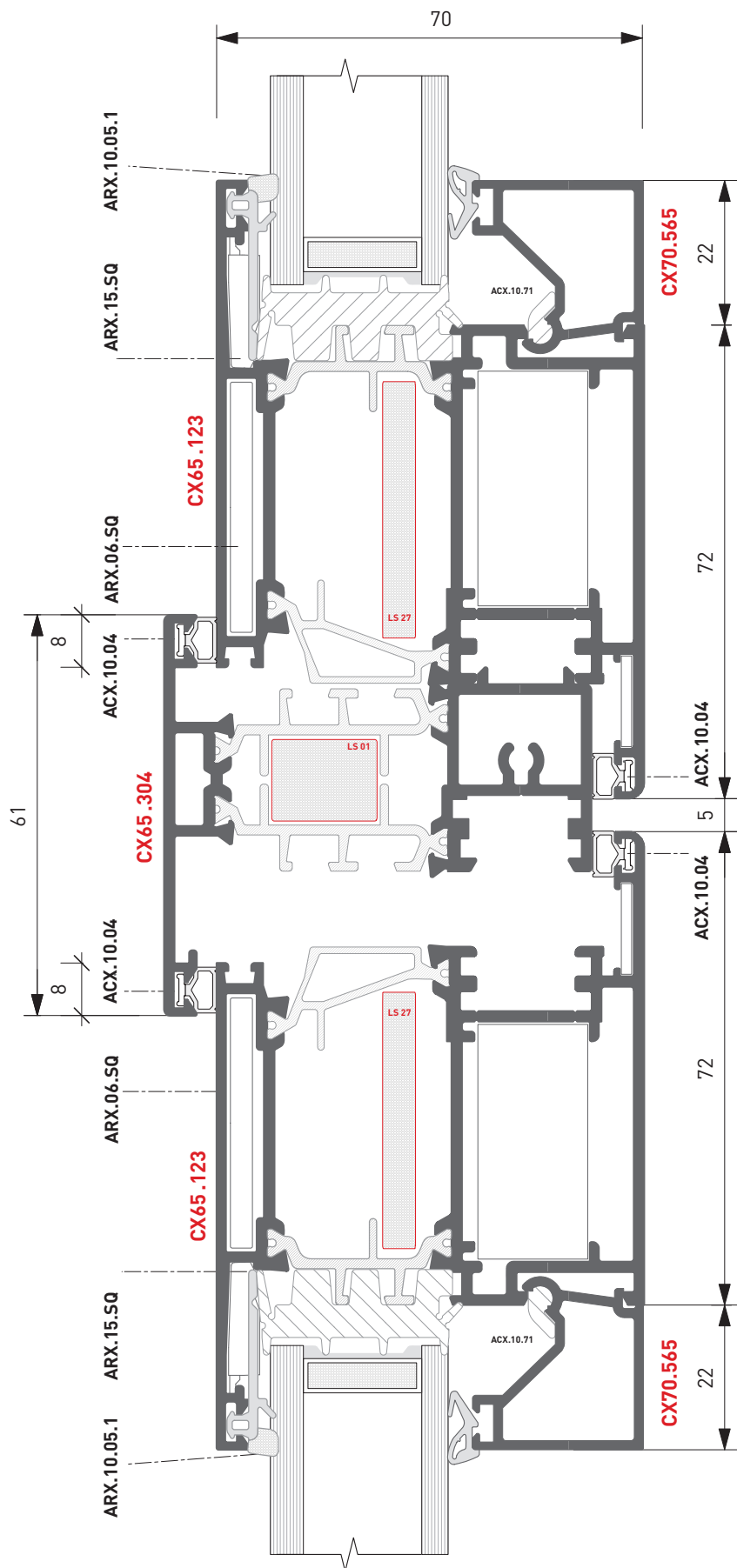
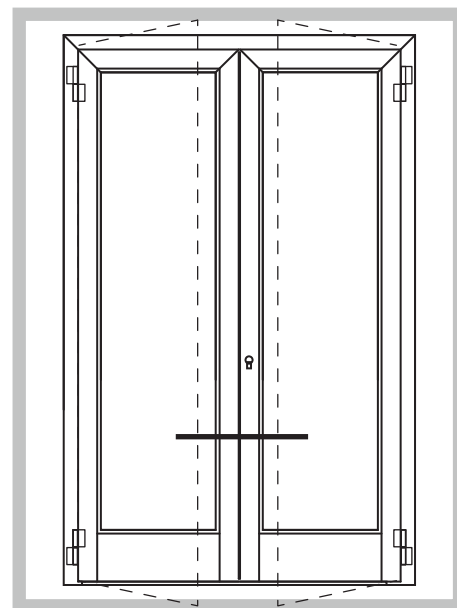



PORTA A 2 ANTE CON SOPRALUCE FISSO
APERTURA ESTERNA
DOUBLE SASH WINDOW + FIXED FANLIGHT TRANSOM
OPEN OUTSIDE

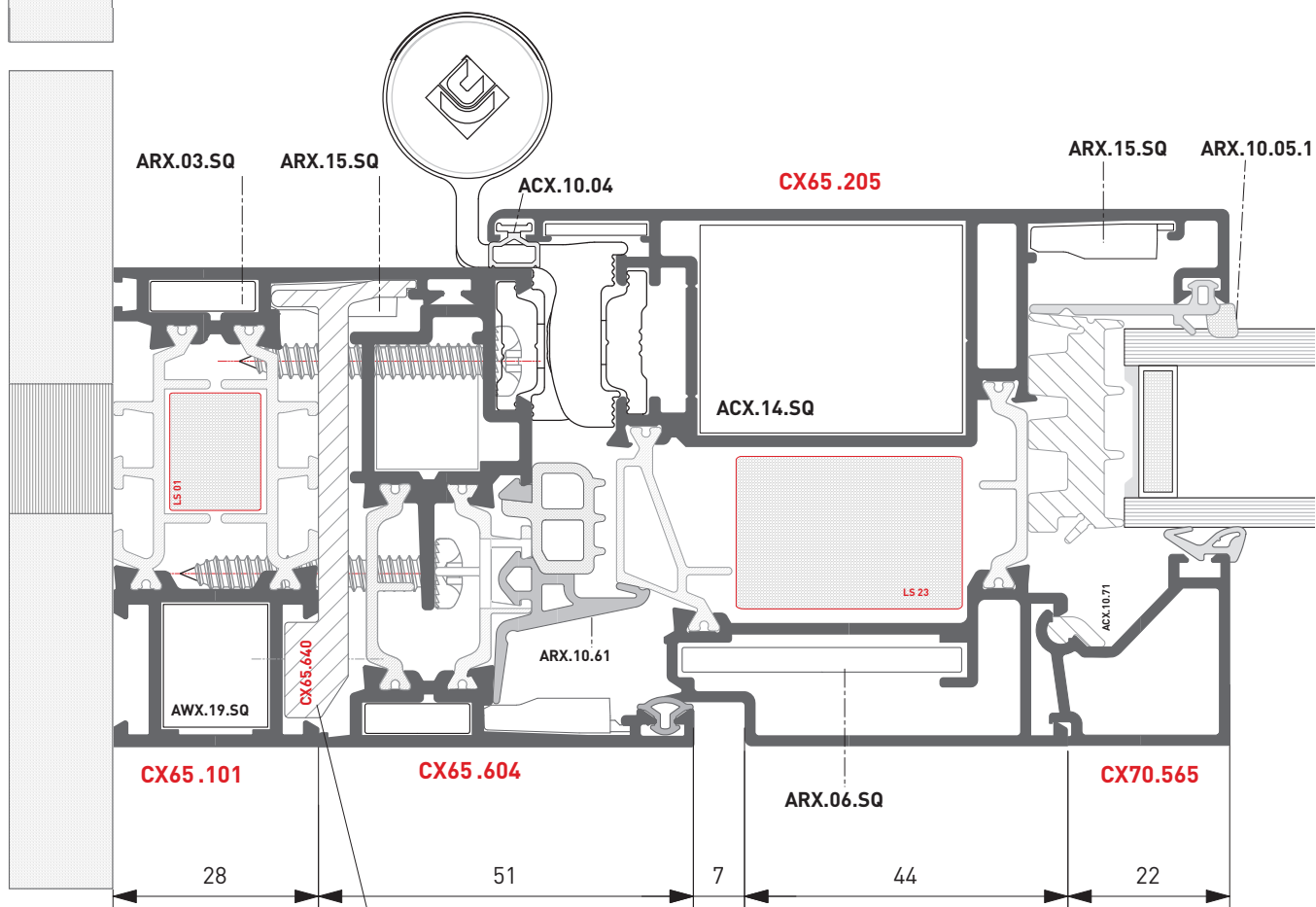
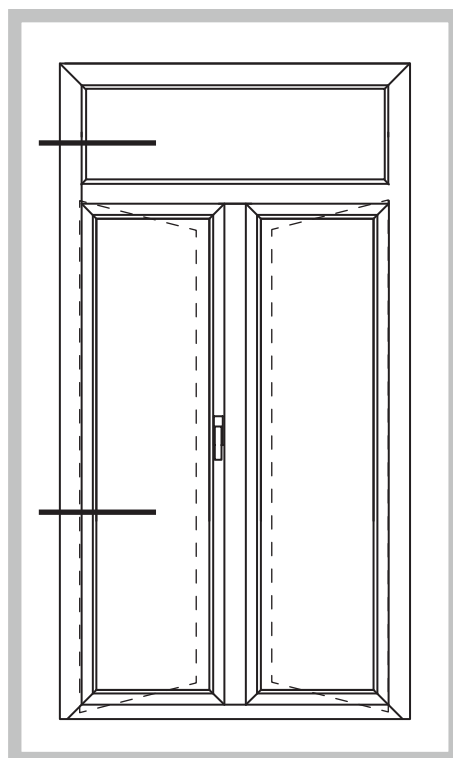
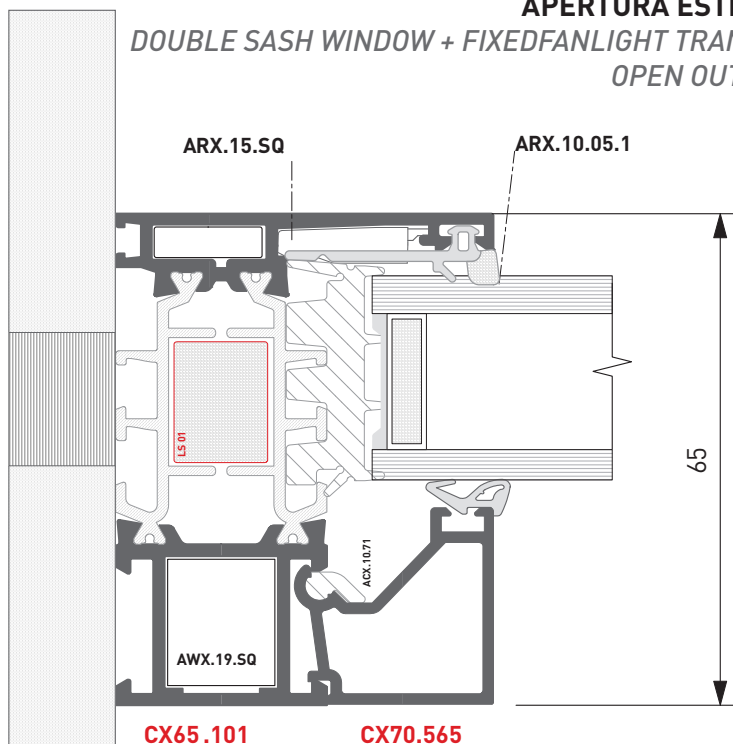

Utilizzare a pezzi in corrispondenza fissaggi. *Use in pieces at fixing points.*



FINESTRA MONOBLOCCO
MONOBLOC WINDOW

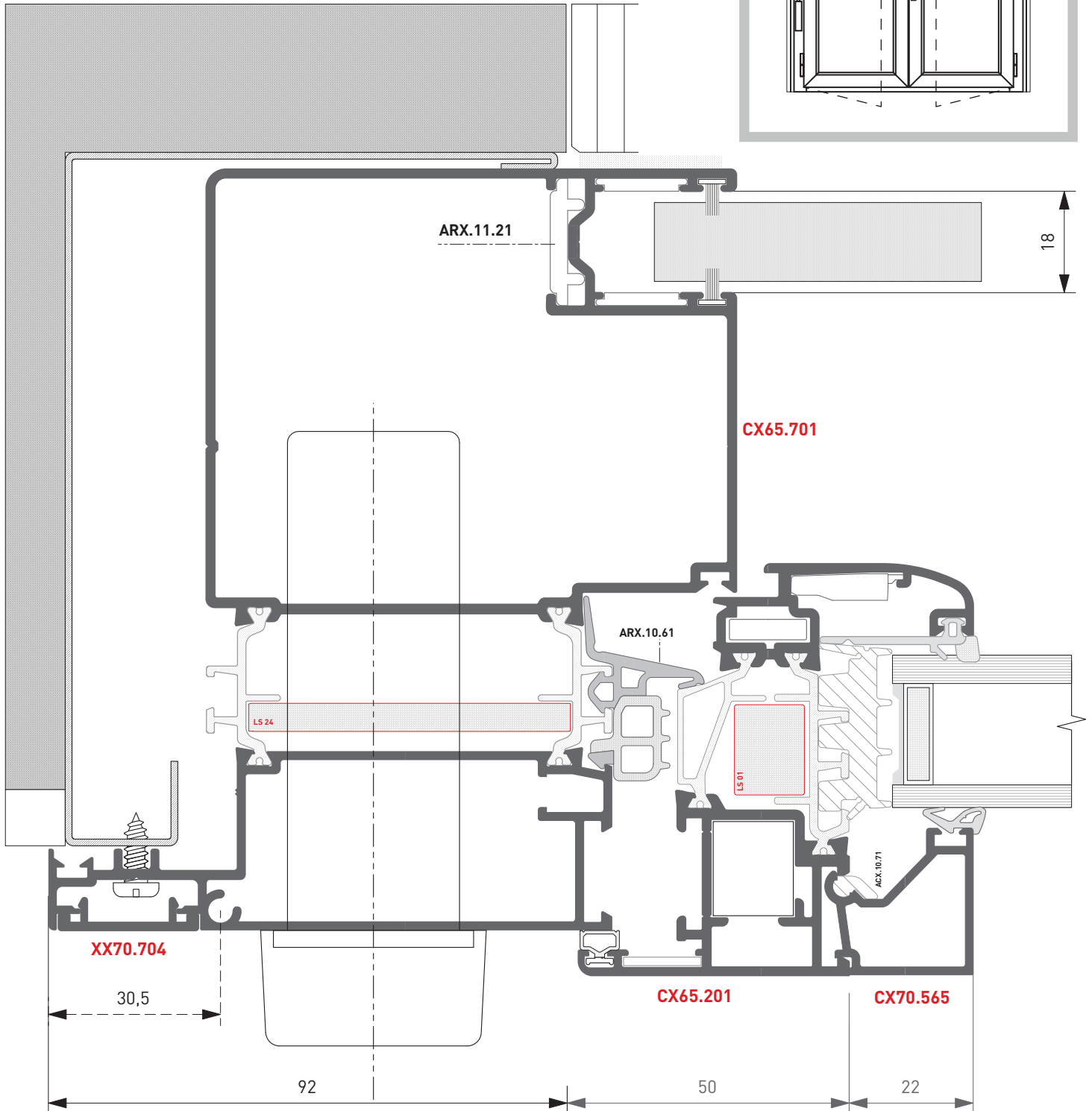
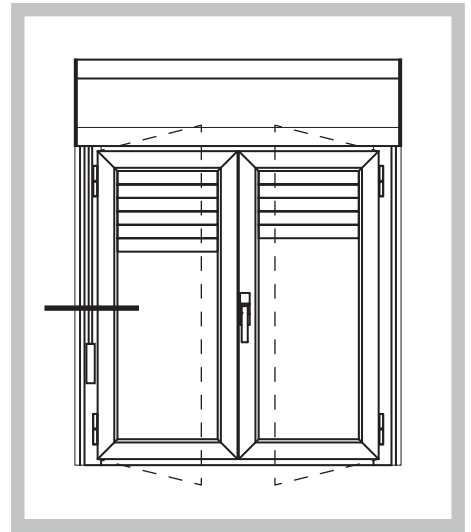



FINESTRA MONOBLOCCO
MONOBLOC WINDOW

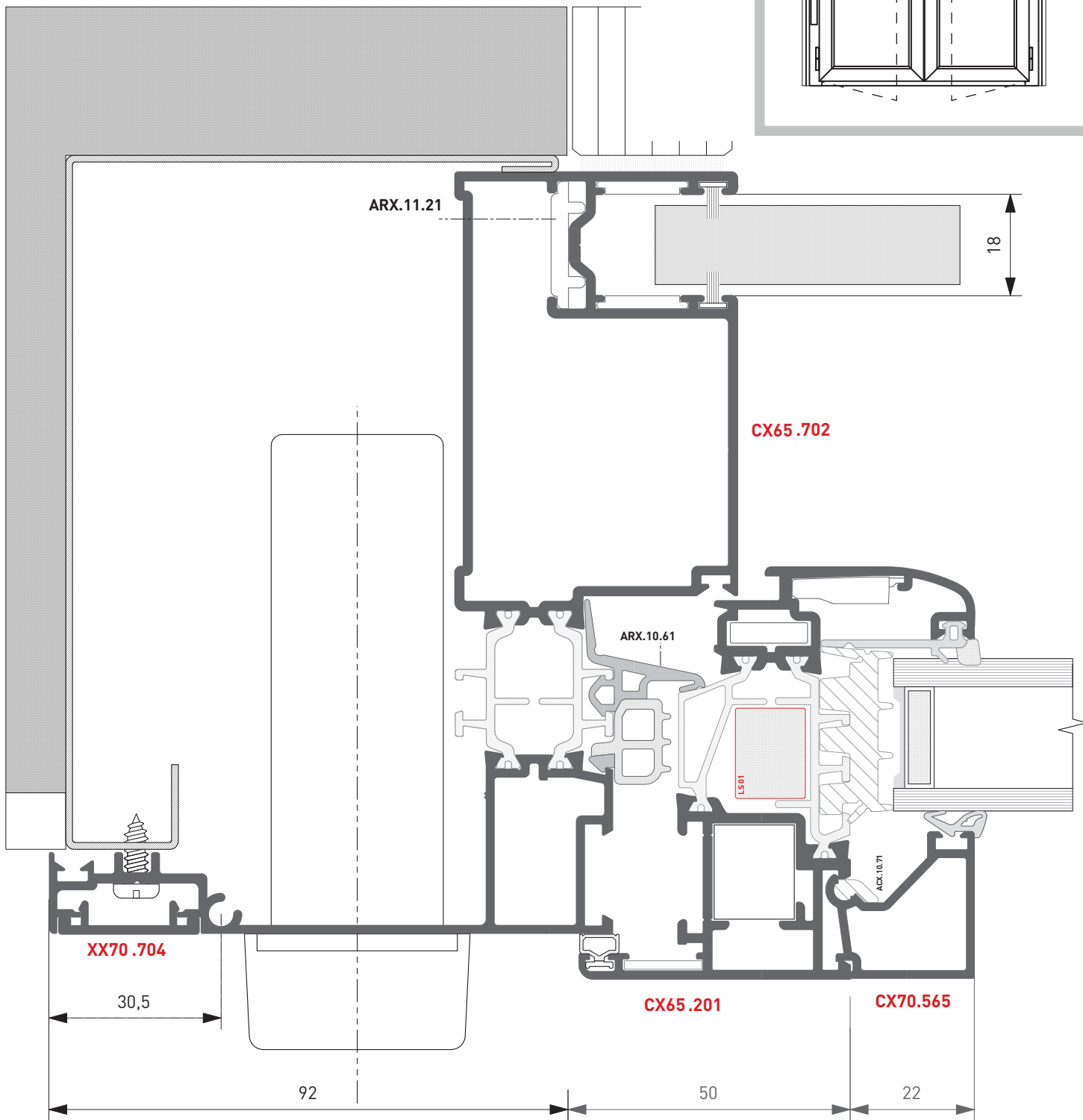
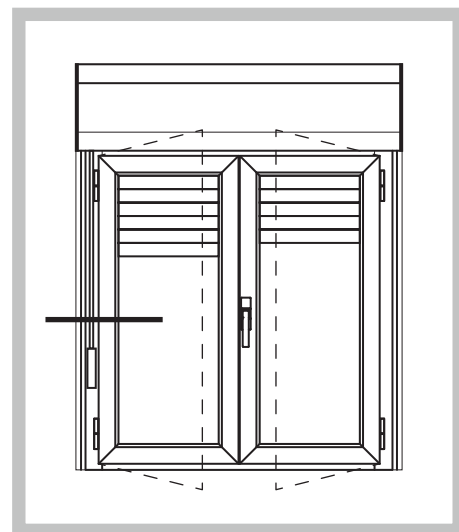



FINESTRA MONOBLOCCO
MONOBLOC WINDOW

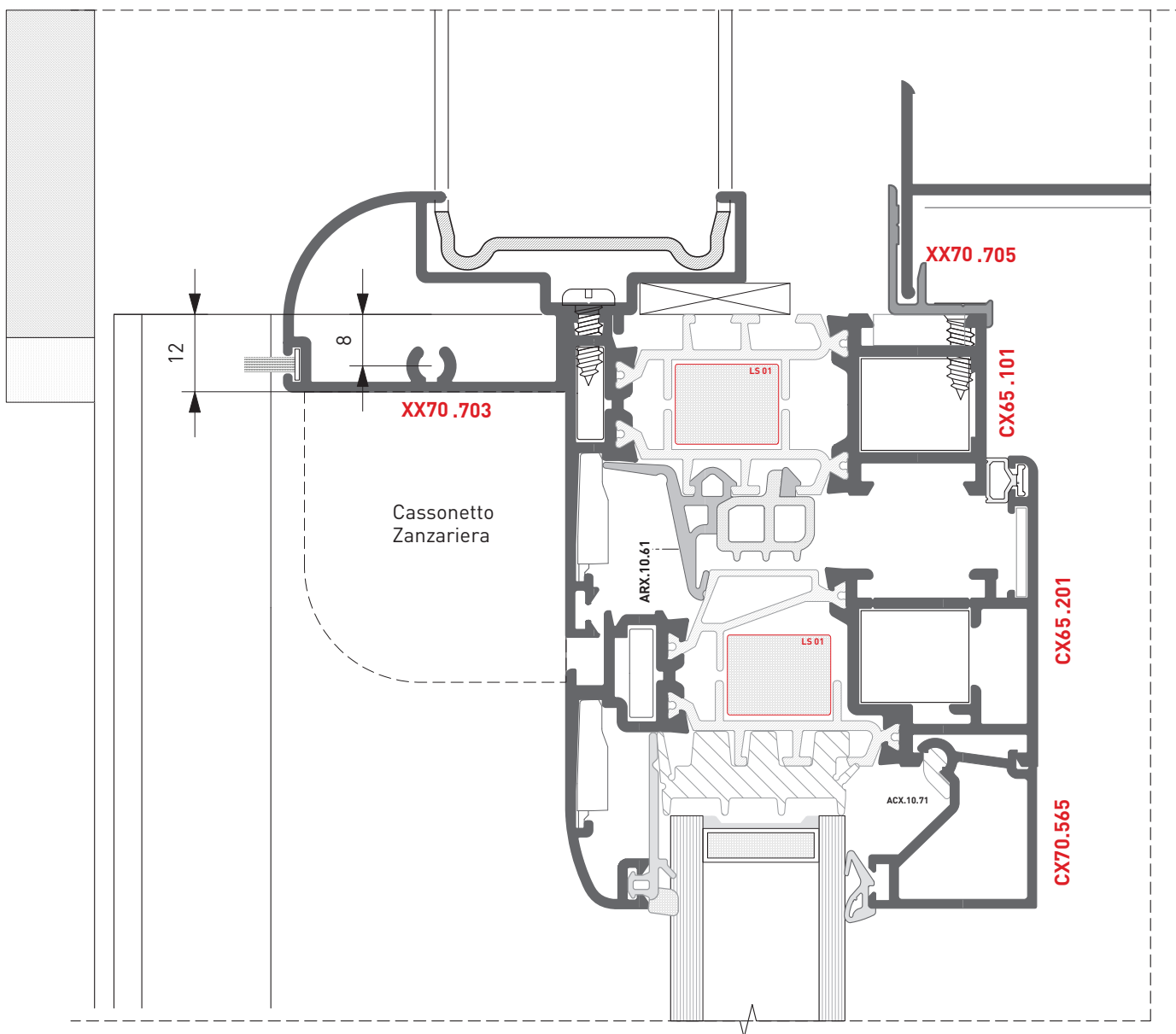
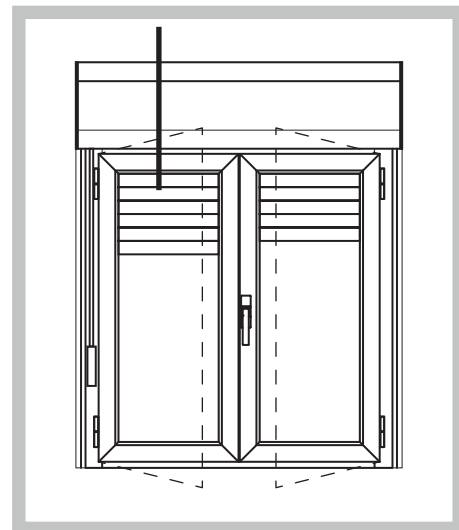



FINESTRA MONOBLOCCO
MONOBLOC WINDOW

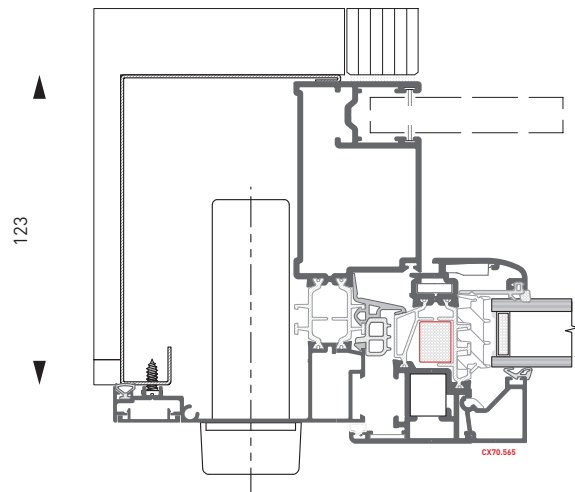
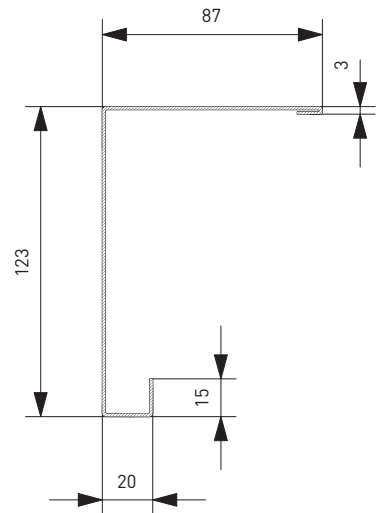
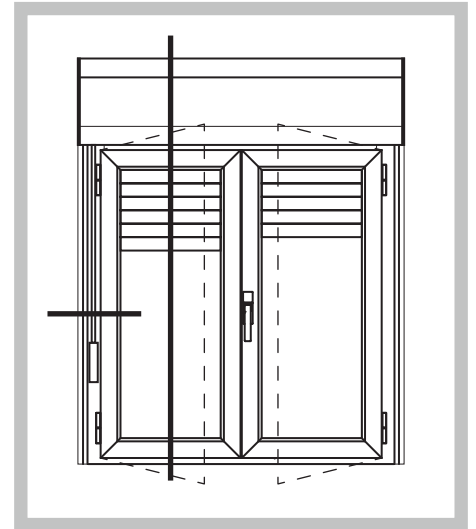
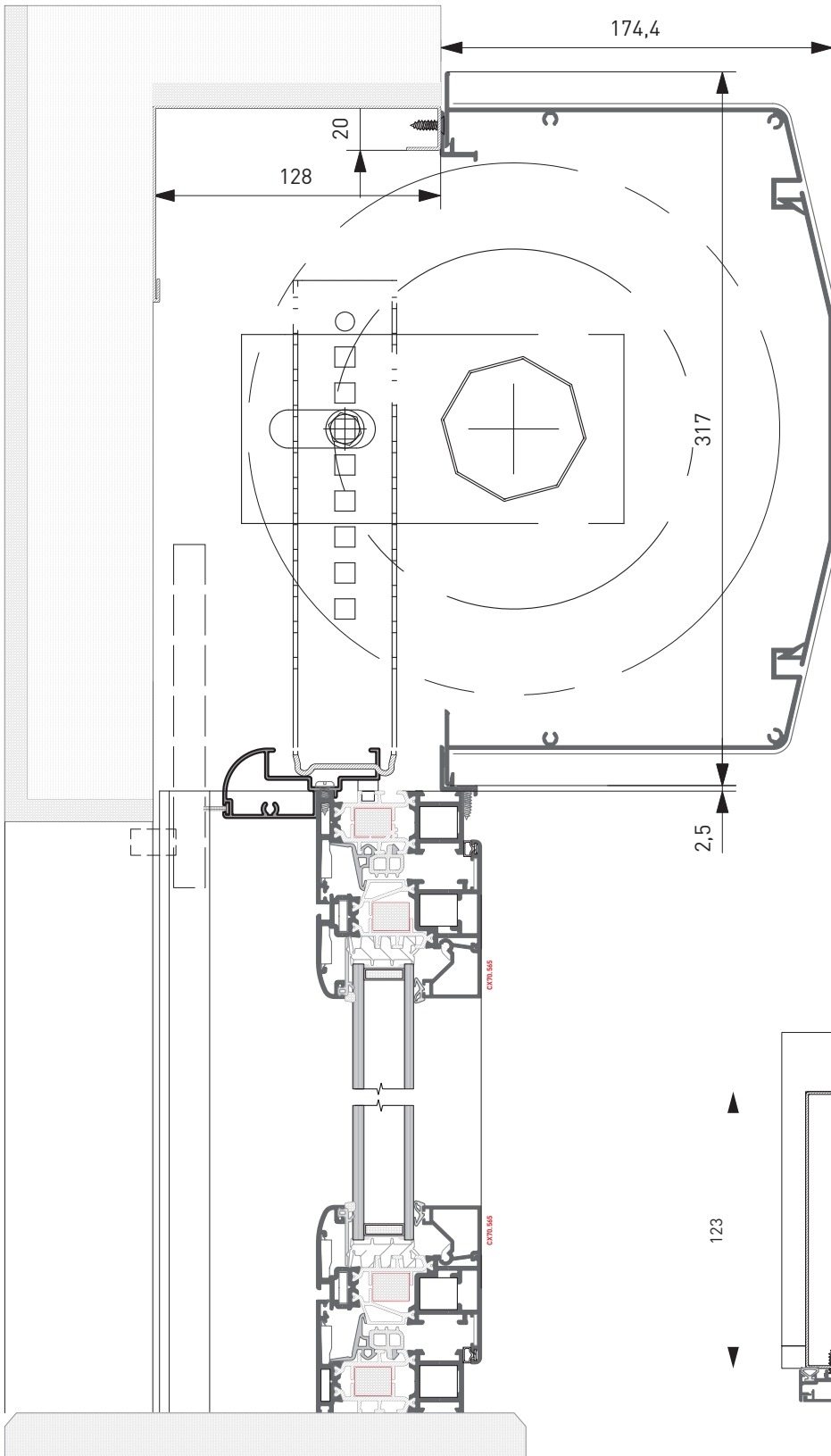



FINESTRA A 2 ANTE
DOUBLE SASH WINDOW

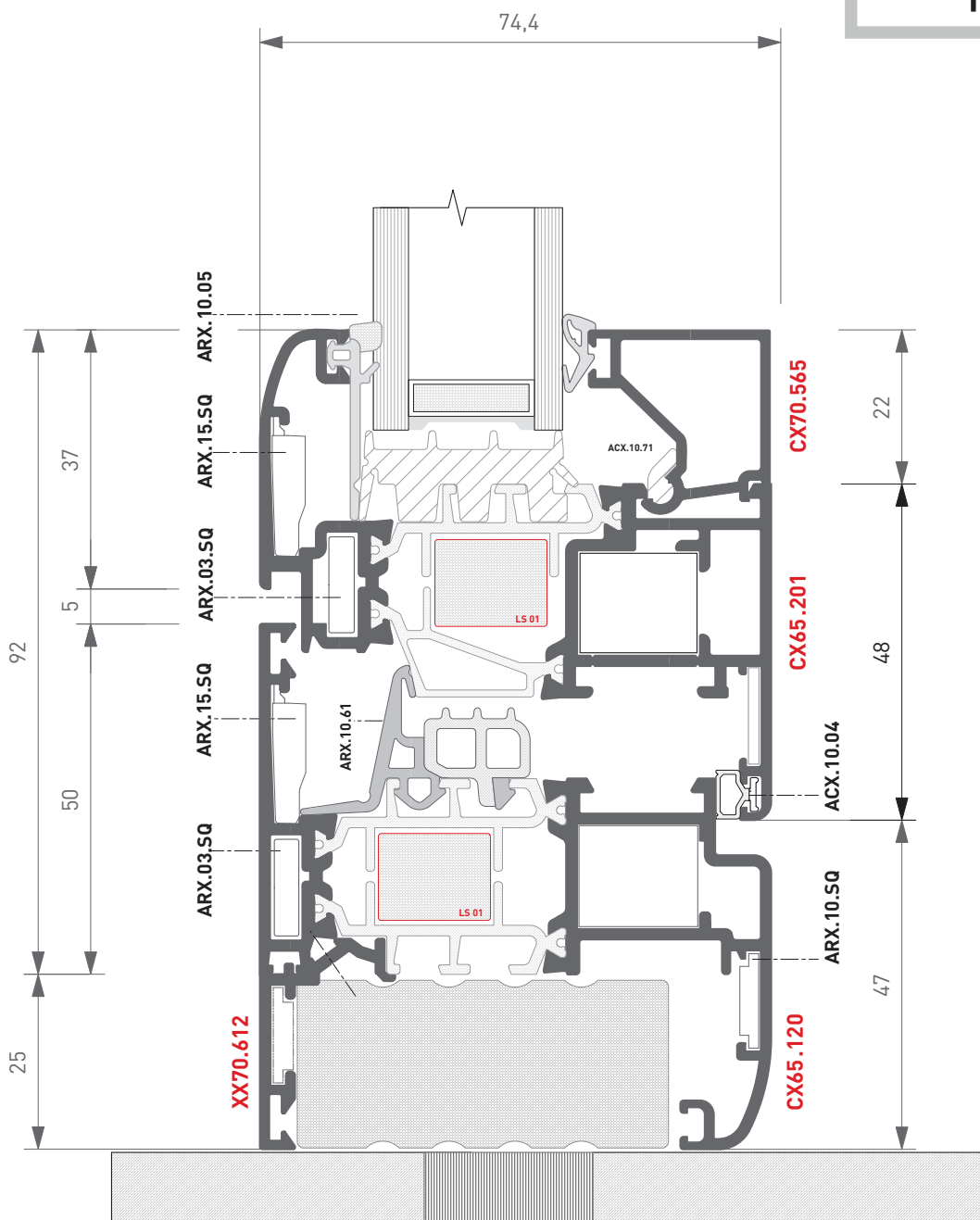
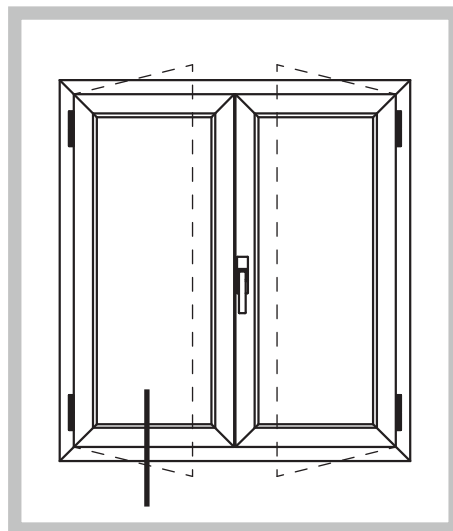



FINESTRA A 2 ANTE
APERTURA ESTERNA
DOUBLE SASH WINDOW
OPEN OUTSIDE

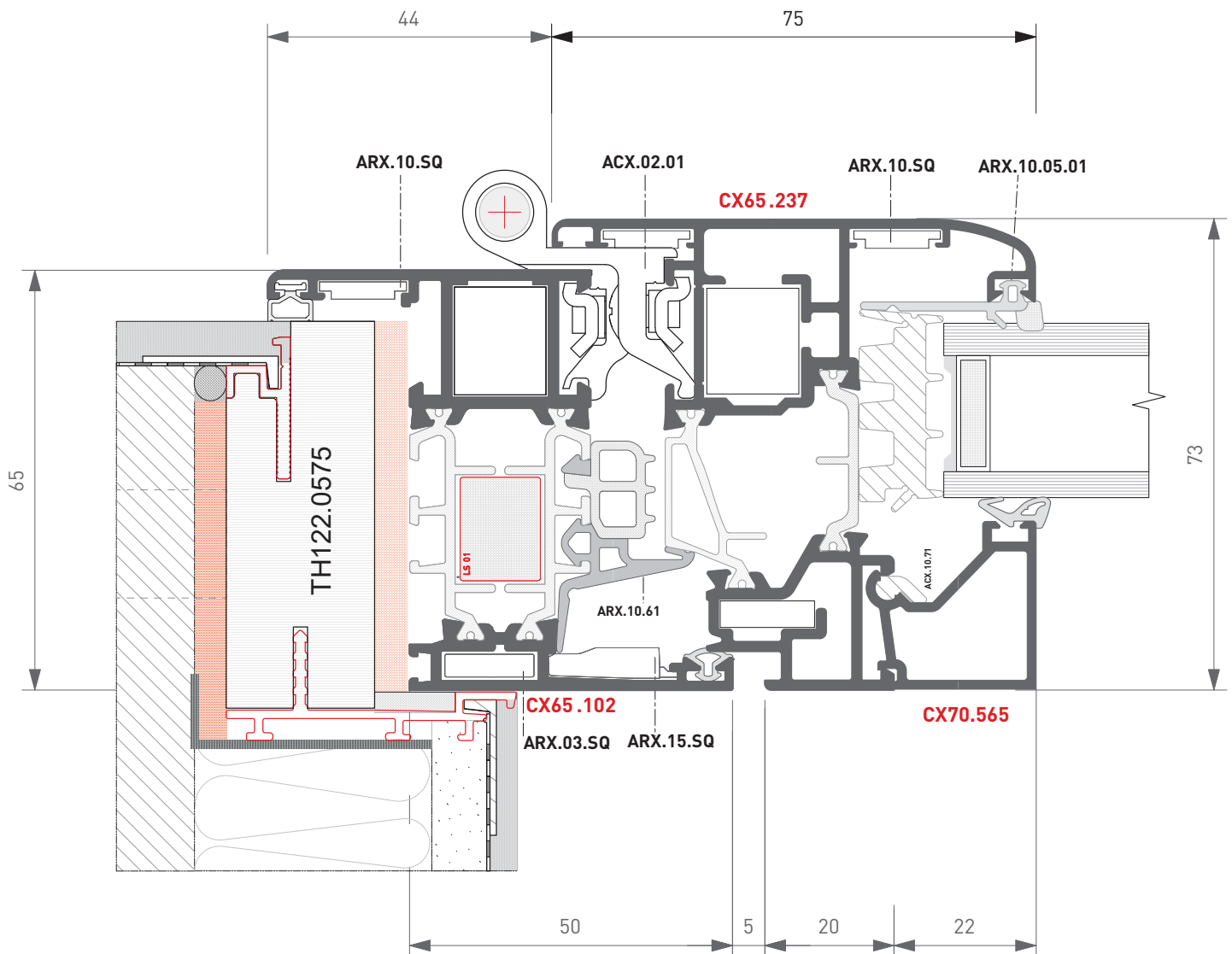
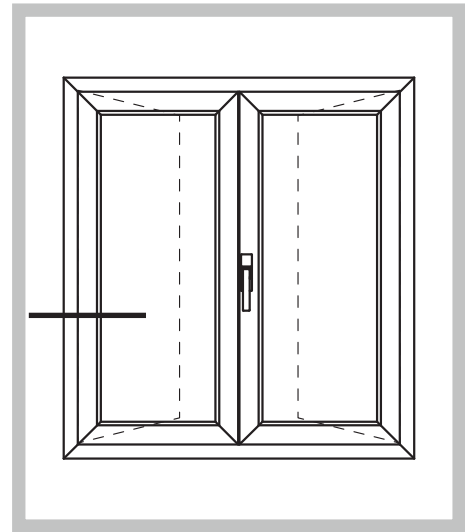



FINESTRA A 2 ANTE
APERTURA ESTERNA
DOUBLE SASH WINDOW
OPEN OUTSIDE

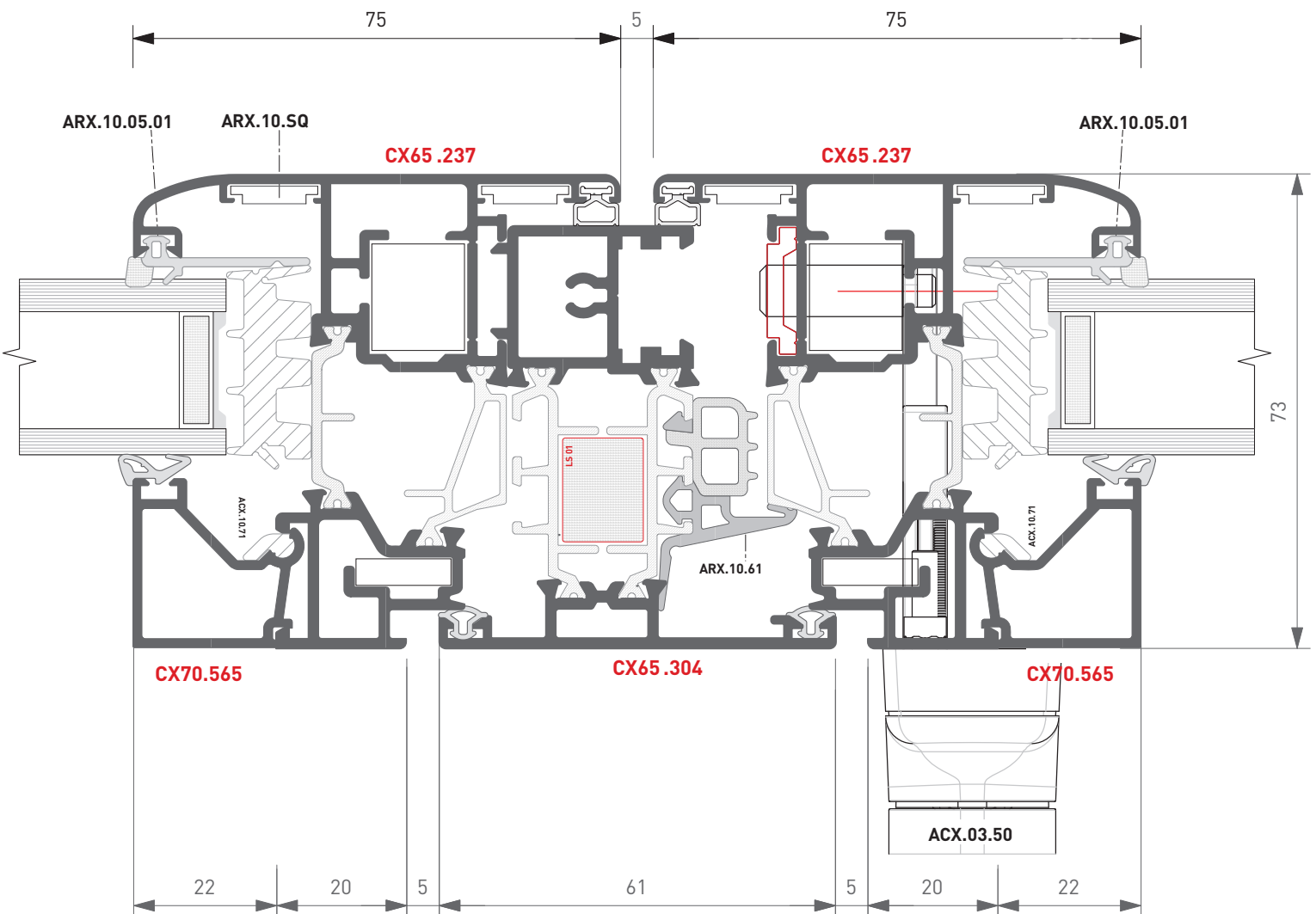
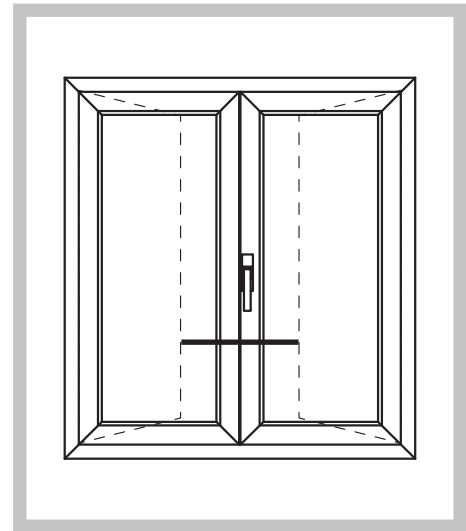

**FINESTRA A 2 ANTE
CON SCURETTO**
DOUBLE SASH WINDOW
W/SHUTTER

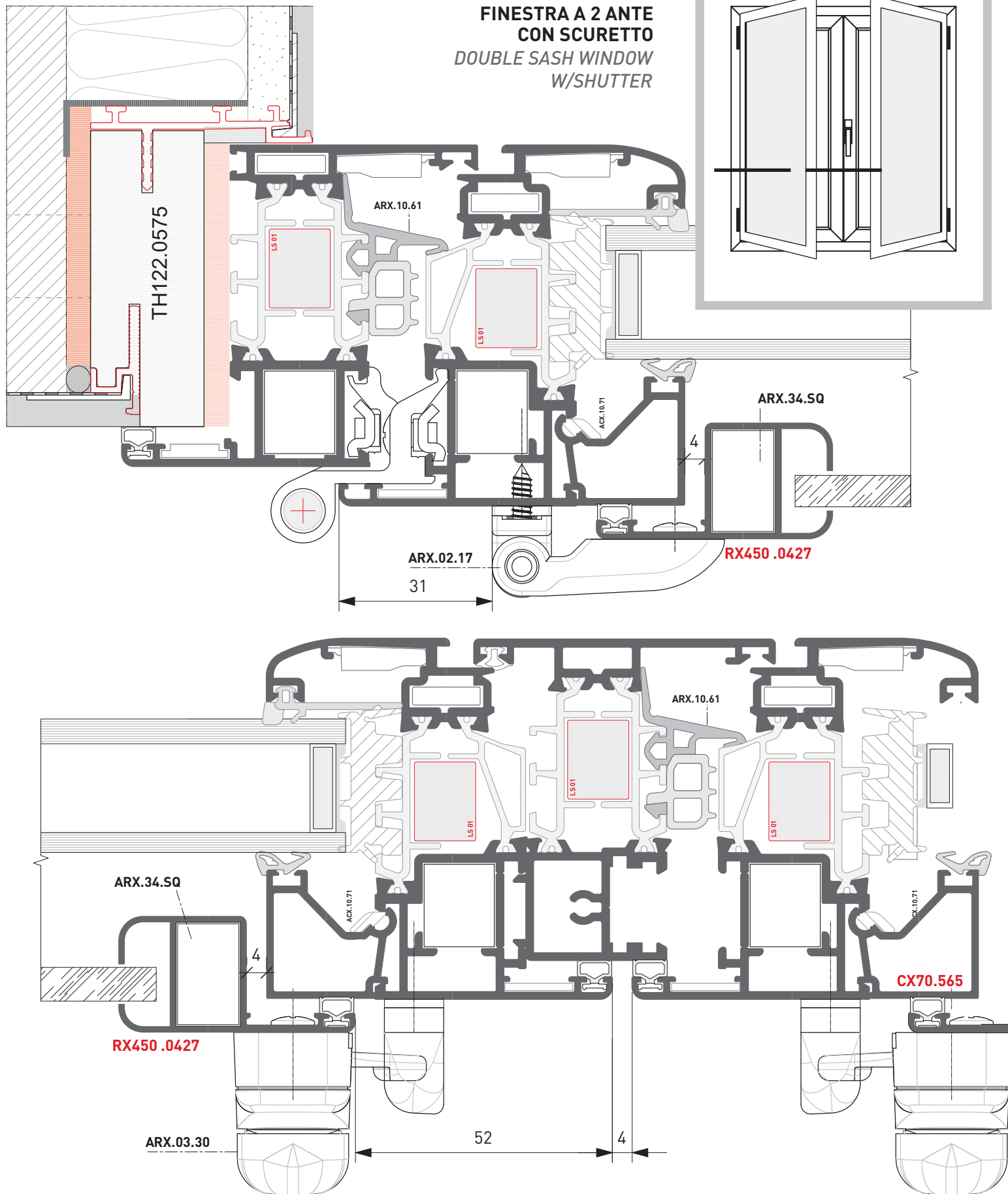



PORTA A 2 ANTE
PROFILO DOGA XX70.636
DOUBLE SASH DOOR
STAVE PROFILE XX70.636

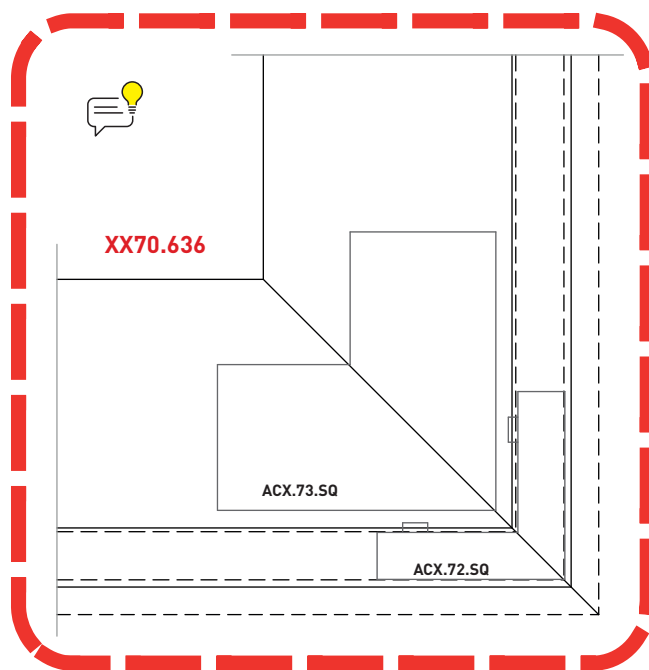
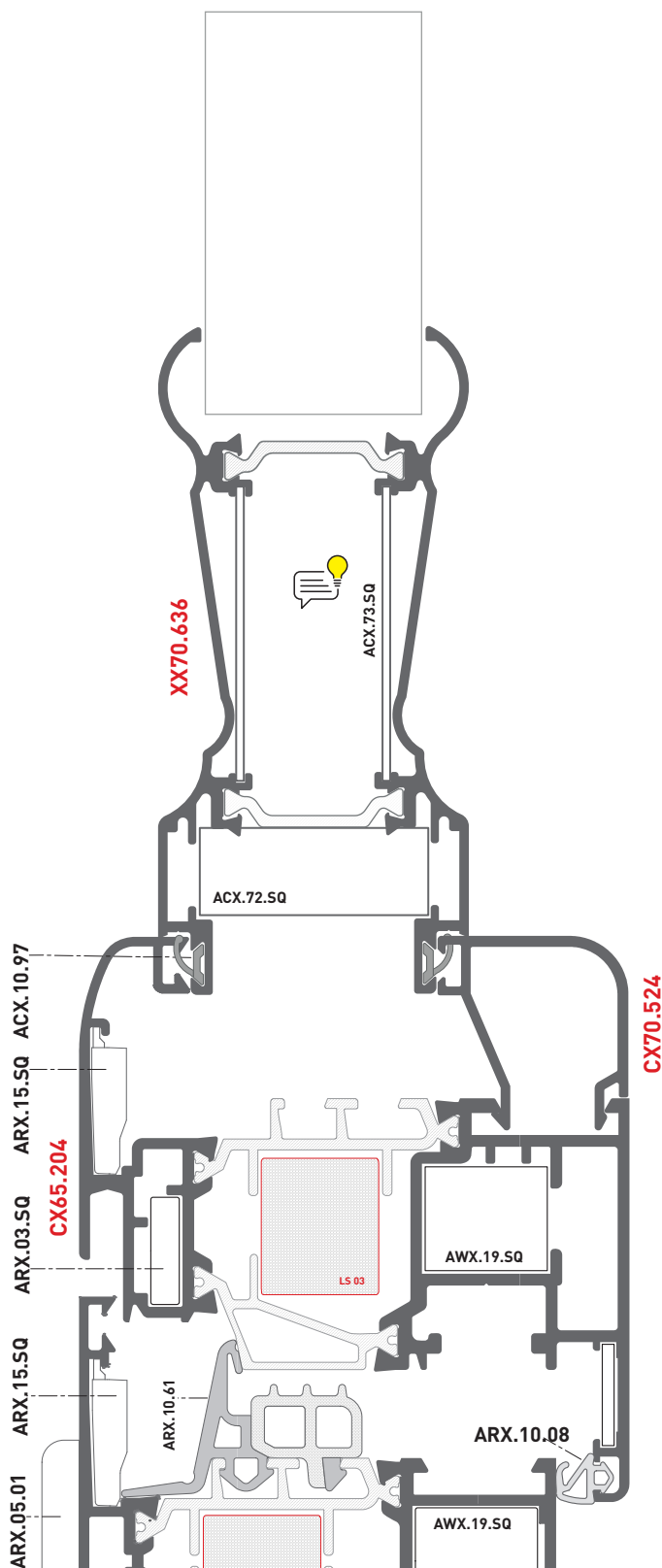
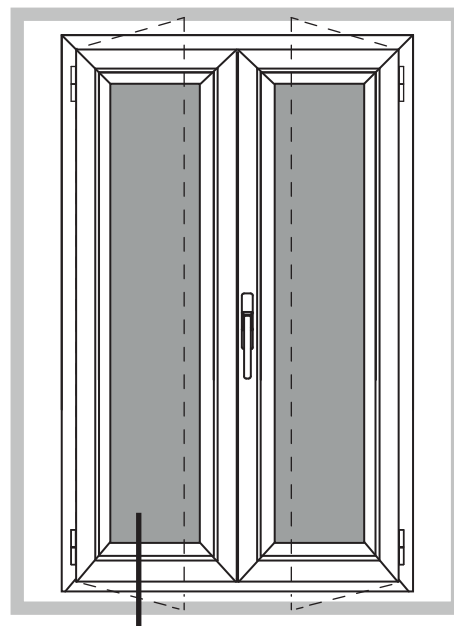



Tipologie
Types

Gruppo **E**

Tipologie  *Main Sections*



Finestra 1 Anta
1 Sash Window

Accessori & Guarnizioni | Accessories & Gaskets

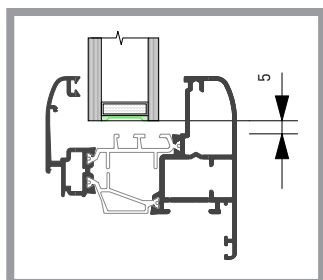
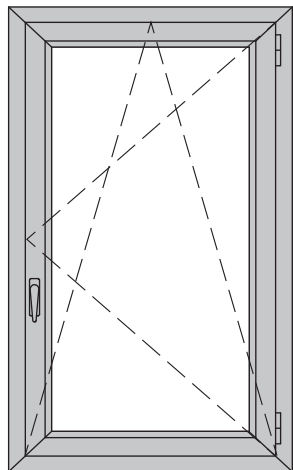

Art. Code	Descrizione Description	Qt.
AWX.19.SQ	Squadretta Telaio /Anta Frame/door corner connection	8
ARX.03.SQ	Squad. Cianfrinare EXT. External riveting corner joint	8
ARX.10.SQ	Squad. Allin. Anta INT. Internal door aligning corner joint	4
ARX.15.SQ	Squad. Allin. Telaio/Anta Frame/door aligning corner joint	8
ACX.02.01	Cerniera 2 Ali 2-leafed hinge	2
ARX.03.06	Cremonese Pressofusa Die-cast Cremonese bolt	1
ACX.03.14	Ferrogliera Striker plate	2
ACX.03.17	Innesti Cremonese Cremonese bolt connections	1
ACX.03.18	Terminale Astina Bar Terminal	2
ARX.05.01	Copriaccola Scarico Acqua Water drainage slot cover	2
ARX.06.01	Espansore Expander	*
ACX.10.04	Guarnizione Battuta Rabbet window gasket	2H-2L
ARX.10.05.1	Guarnizione Vetro EXT External glass window gasket	2H-2L
*ARX.10.XX	Guarnizione Vetro INT Internal glass window gasket	2H-2L
ARX.10.61	Guarnizione Precamera Prechamber Gasket	2H-2L
ARX.10.62	Angolo per Guarnizione centrale di Precamera ARX.10.61 Corner for pre-chamber central window gasket ARX.10.61	4
ARX.10.73	Guarnizione sotto vetro Gasket under glass	2H-2L

* Secondo Dimensioni | Depending on size

DISTINTA Taglio Vetri Glass Cutting List		
Qt.	H	L
1	H-150	L-150
Spazio/Gap 5 mm.		

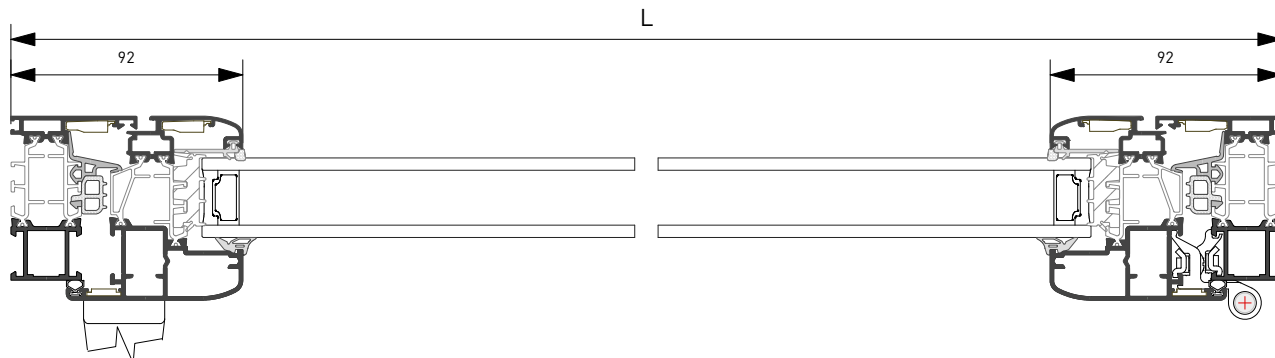
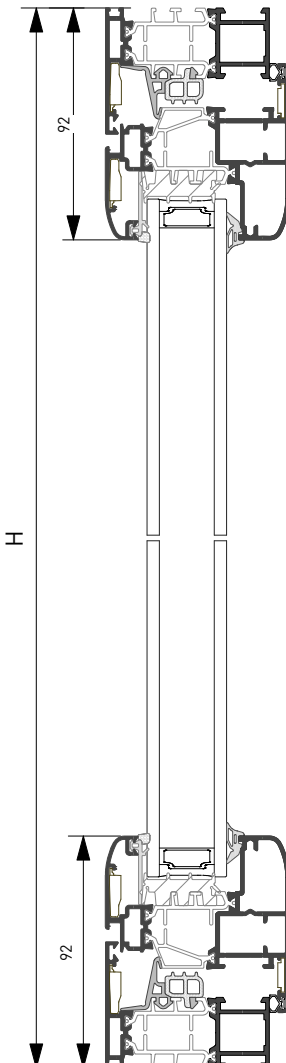

Profilo Profile	Taglio CUT	Qt.	Profilo Profile	Taglio CUT	Qt.	Profilo Profile	Taglio CUT	Qt.
CX65.101 		2	CX70.605 					
		2						
CX65.203 		2						
		2						



Finestra 2 Ante
2 Sashes Window

Accessori & Guarnizioni | Accessories & Gaskets

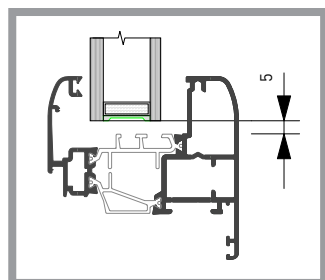
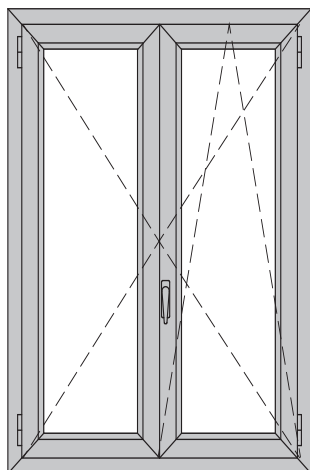

Art. Code	Descrizione Description	Qt.
AWX.19.SQ	Squadretta Telaio /Anta Frame/door corner connection	12
ARX.03.SQ	Squad. Cianfrinare EXT. External riveting corner joint	12
ARX.10.SQ	Squad. Allin. Anta INT. Internal door aligning corner joint	8
ARX.15.SQ	Squad. Allin. Telaio/Anta Frame/door aligning corner joint	12
ACX.02.01	Cerniera 2 Ali 2-leafed hinge	4
ARX.03.06	Cremonese Pressofusa Die-cast Cremonese bolt	1
ACX.03.14	Ferrogliera Striker plate	2
ACX.03.17	Innesti Cremonese Cremonese bolt connections	1
ACX.03.18	Terminale Astina Bar Terminal	2
ACX.03.71	Paletto mini TEX mini TEX lever bolt	2
ACX.04.51	Tappo Rlporto Centrale Central wing cap	1
ARX.05.01	Copriaccola Scarico Acqua Water drainage slot cover	2
ARX.06.01	Espansore Expander	*
ACX.10.04	Guarnizione Battuta Rabbet window gasket	4H-2L
ARX.10.05.1	Guarnizione Vetro EXT External glass window gasket	4H-2L
*ARX.10.XX	Guarnizione Vetro INT Internal glass window gasket	4H-2L
ARX.10.61	Guarnizione Precamera Prechamber Gasket	3H-2L
ARX.10.62	Angolo per Guarnizione centrale di Precamera ARX.10.61 Corner for pre-chamber central window gasket ARX.10.61	4
ARX.10.73	Guarnizione sotto vetro Gasket under glass	4H-2L

* Secondo Dimensioni | Depending on size

DISTINTA Taglio Vetri Glass Cutting List		
Qt.	H	L
2	H-150	L/2-130.5
Spazio/Gap 5 mm.		

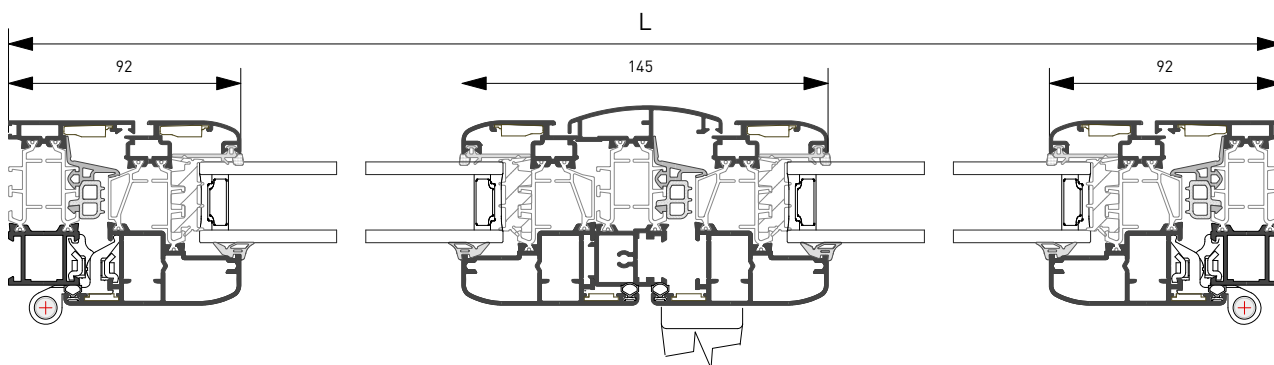
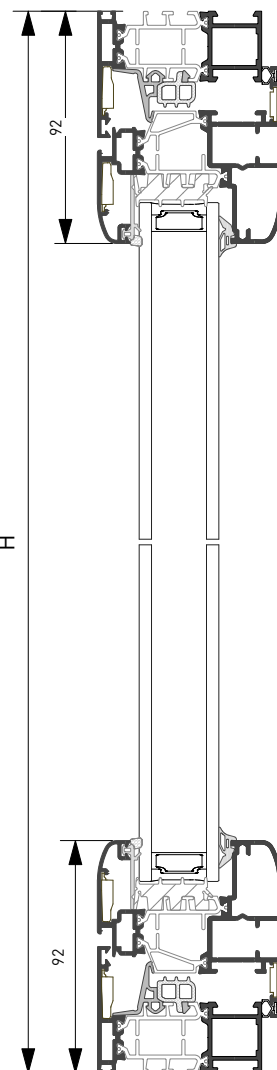

Profilo Profile	Taglio CUT	Qt.	Profilo Profile	Taglio CUT	Qt.	Profilo Profile	Taglio CUT	Qt.
CX65.101 	L	2	CX65.301 	H - 110	1			
	H	2						
CX65.203 	L/2 - 24.5	4	CX70.605 					
	H - 44	4						



Finestra 1 Anta
1 Sash Window

Accessori & Guarnizioni | Accessories & Gaskets

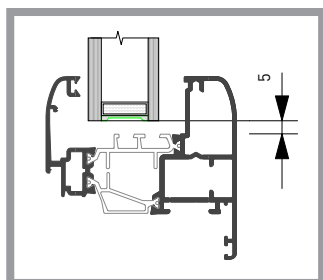
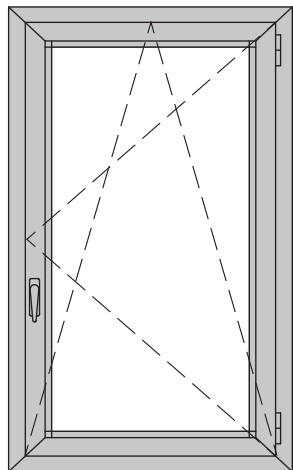

Art. Code	Descrizione Description	Qt.
AWX.19.SQ	Squadretta Telaio /Anta Frame/door corner connection	8
ARX.03.SQ	Squad. Cianfrinare EXT. External riveting corner joint	8
ARX.10.SQ	Squad. Allin. Anta INT. Internal door aligning corner joint	4
ARX.15.SQ	Squad. Allin. Telaio/Anta Frame/door aligning corner joint	8
ACX.02.01	Cerniera 2 Ali 2-leafed hinge	2
ARX.03.06	Cremonese Pressofusa Die-cast Cremonese bolt	1
ACX.03.14	Ferrogliera Striker plate	2
ACX.03.17	Innesti Cremonese Cremonese bolt connections	1
ACX.03.18	Terminale Astina Bar Terminal	2
ARX.05.01	Copriaccola Scarico Acqua Water drainage slot cover	2
ARX.06.01	Espansore Expander	*
ACX.07.02	Angolo Pressofuso Fermavetro Die-cast glazing bead corner	4
ACX.10.04	Guarnizione Battuta Rabbet window gasket	2H-2L
ARX.10.05.1	Guarnizione Vetro EXT External glass window gasket	2H-2L
*ARX.10.XX	Guarnizione Vetro INT Internal glass window gasket	2H-2L
ARX.10.61	Guarnizione Precamera Prechamber Gasket	2H-2L
ARX.10.62	Angolo per Guarnizione centrale di Precamera ARX.10.61 Corner for pre-chamber central window gasket ARX.10.61	4
ARX.10.73	Guarnizione sotto vetro Gasket under glass	2H-2L

* Secondo Dimensioni | Depending on size

DISTINTA Taglio Vetri		
Qt.	H	L
1	H-150	L-150
Spazio/Gap 5 mm.		

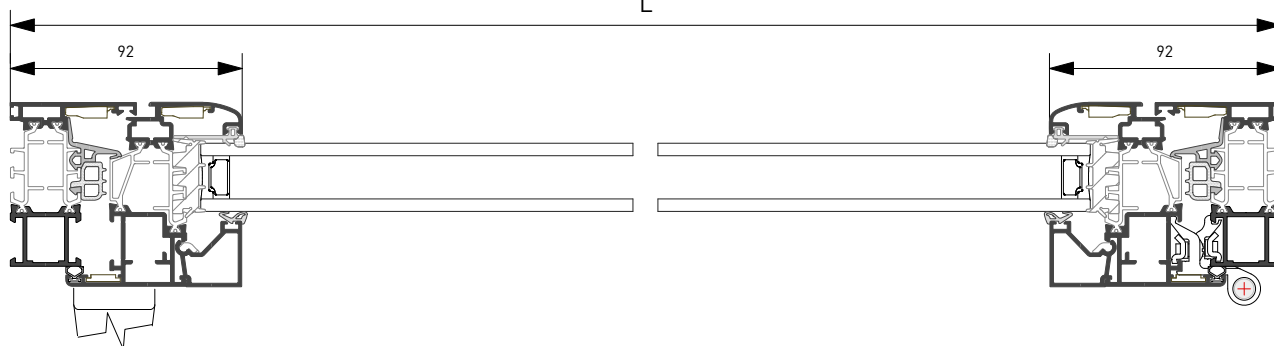
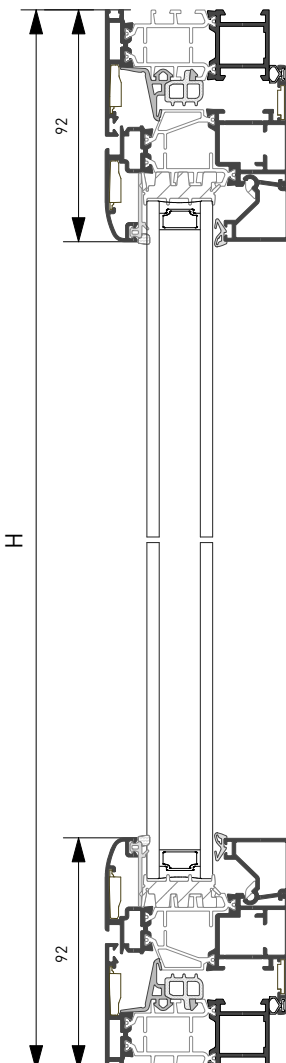

Profilo Profile	Taglio CUT	Qt.	Profilo Profile	Taglio CUT	Qt.	Profilo Profile	Taglio CUT	Qt.
CX65.101	L	2	CX70.565	L - 184	2			
	H	2		H - 184	2			
CX65.201	L - 44	2	CX70.605					
	H - 44	2						



Finestra 2 Ante
2 Sashes Window

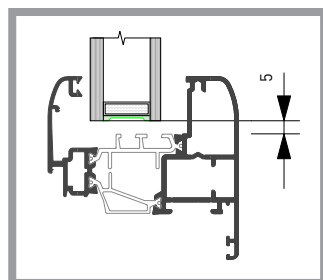
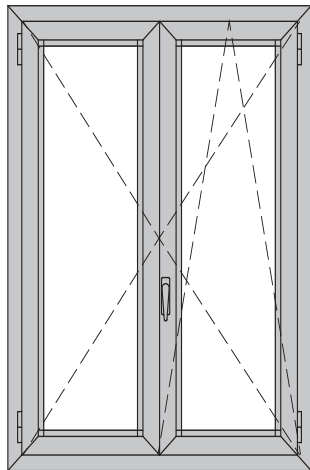

Accessori & Guarnizioni | Accessories & Gaskets

Art. Code	Descrizione Description	Qt.
AWX.19.SQ	Squadretta Telaio /Anta Frame/door corner connection	12
ARX.03.SQ	Squad. Cianfrinare EXT. External riveting corner joint	12
ARX.10.SQ	Squad. Allin. Anta INT. Internal door aligning corner joint	8
ARX.15.SQ	Squad. Allin. Telaio/Anta Frame/door aligning corner joint	12
ACX.02.01	Cerniera 2 Ali 2-leafed hinge	4
ARX.03.06	Cremonese Pressofusa Die-cast Cremonese bolt	1
ACX.03.14	Ferrogliera Striker plate	2
ACX.03.17	Innesti Cremonese Cremonese bolt connections	1
ACX.03.18	Terminale Astina Bar Terminal	2
ACX.03.71	Paletto mini TEX mini TEX lever bolt	2
ACX.04.51	Tappo Riparto Centrale Central wing cap	1
ARX.05.01	Copriasola Scarico Acqua Water drainage slot cover	2
ARX.06.01	Espansore Expander	*
ACX.07.02	Angolo Pressofuso Fermavetro Die-cast glazing bead corner	8
ACX.10.04	Guarnizione Battuta Rabbet window gasket	4H-2L
ARX.10.05.1	Guarnizione Vetro EXT External glass window gasket	4H-2L
*ARX.10.XX	Guarnizione Vetro INT Internal glass window gasket	4H-2L
ARX.10.61	Guarnizione Precamera Prechamber Gasket	3H-2L
ARX.10.62	Angolo per Guarnizione centrale di Precamera ARX.10.61 Corner for pre-chamber central window gasket ARX.10.61	4
ARX.10.73	Guarnizione sotto vetro Gasket under glass	4H-2L

* Secondo Dimensioni | Depending on size

DISTINTA Taglio Vetri | Glass Cutting List

Qt.	H	L
2	H-150	L/2-130.5
Spazio/Gap 5 mm.		

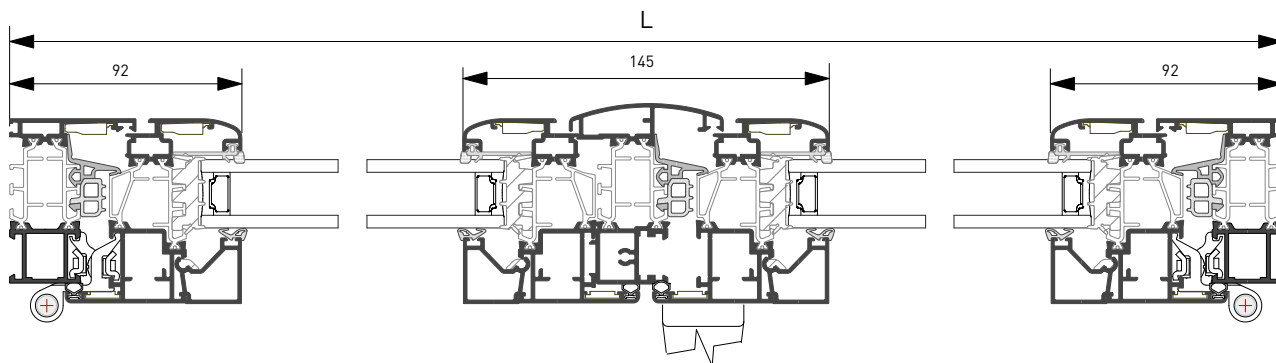
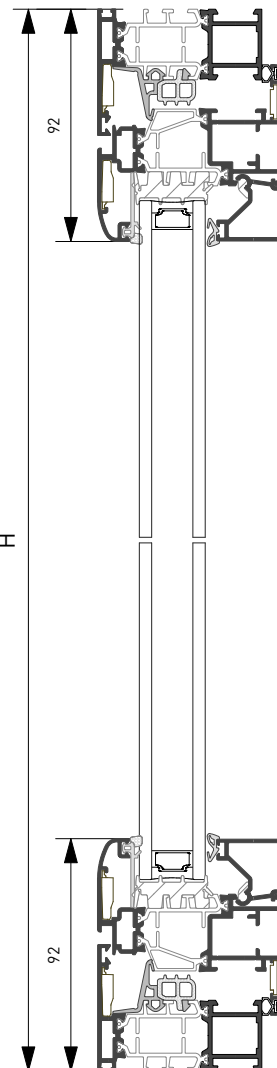

Profilo Profile	Taglio CUT	Qt.	Profilo Profile	Taglio CUT	Qt.	Profilo Profile	Taglio CUT	Qt.
CX65.101	L	2	CX70.565	L/2 - 164.5	4	CX70.605		
	H	2		H - 184	4			
CX65.201	L/2 - 24.5	4	CX65.301	H - 110	1			
	H - 44	4						



Porta 1 Anta
1 Sash Door

Accessori & Guarnizioni | Accessories & Gaskets

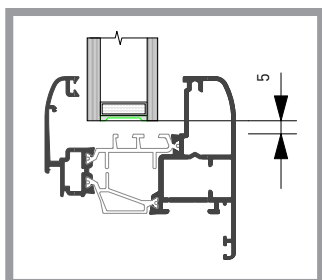
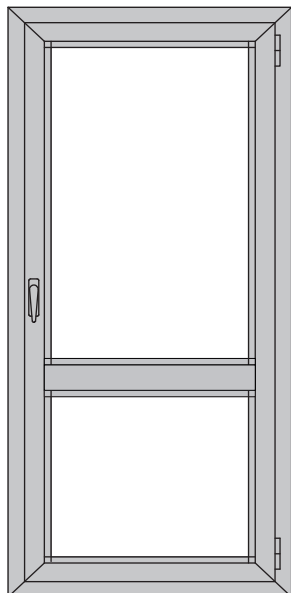

Art. Code	Descrizione Description	Qt.
AWX.19.SQ	Squadretta Telaio /Anta Frame/door corner connection	8
ARX.03.SQ	Squad. Cianfrinare EXT. External riveting corner joint	8
ARX.10.SQ	Squad. Allin. Anta INT. Internal door aligning corner joint	4
ARX.15.SQ	Squad. Allin. Telaio/Anta Frame/door aligning corner joint	8
ACX.02.01	Cerniera 2 Ali 2-leafed hinge	3
ARX.03.06	Cremonese Pressofusa Die-cast Cremonese bolt	1
ACX.03.14	Ferrogliera Striker plate	2
ACX.03.17	Innesti Cremonese Cremonese bolt connections	1
ACX.03.18	Terminale Astina Bar Terminal	2
ARX.05.01	Copriaccola Scarico Acqua Water drainage slot cover	2
ARX.06.01	Espansore Expander	*
ACX.07.02	Angolo Pressofuso Fermavetro Die-cast glazing bead corner	8
ACX.10.04	Guarnizione Battuta Rabbet window gasket	2H-2L
ARX.10.05.1	Guarnizione Vetro EXT External glass window gasket	2H-4L
*ARX.10.XX	Guarnizione Vetro INT Internal glass window gasket	2H-4L
ARX.10.61	Guarnizione Precamera Prechamber Gasket	2H-2L
ARX.10.62	Angolo per Guarnizione centrale di Precamera ARX.10.61 Corner for pre-chamber central window gasket ARX.10.61	4
ARX.10.73	Guarnizione sotto vetro Gasket under glass	2H-4L

* Secondo Dimensioni | Depending on size

DISTINTA Taglio Vetri Glass Cutting List		
Qt.	H	L
1	H - H_{fa} - 58	L - 150
1	H_{fa} - 154	L - 150

Spazio/Gap 5 mm.

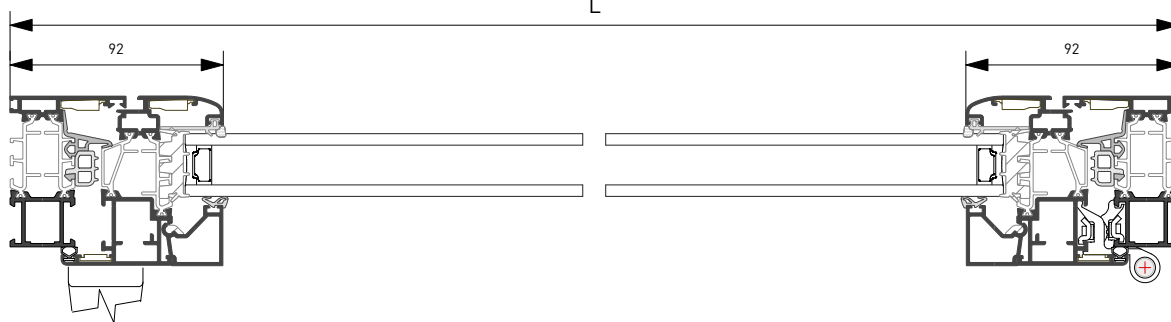
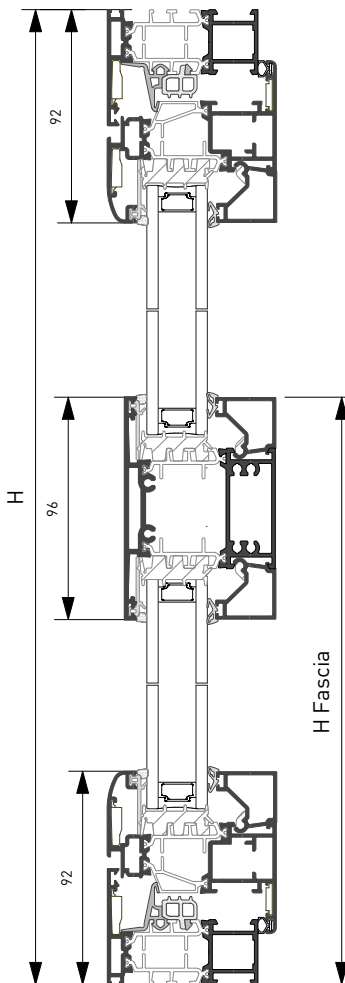

Profilo Profile	Taglio CUT	Qt.	Profilo Profile	Taglio CUT	Qt.	Profilo Profile	Taglio CUT	Qt.
CX65.101 	L	2	CX70.565 	L - 184	4	CX65.402 	L - 130	1
	H	2		H - H _{fa} - 92	2			
CX65.201 	L - 44	2		H _{fa} - 188	2			
	H - 44	2	CX70.605 					



Porta 2 Ante
2 Sashes Door

Accessori & Guarnizioni | Accessories & Gaskets

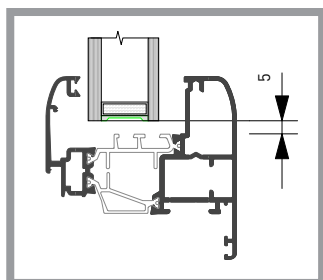
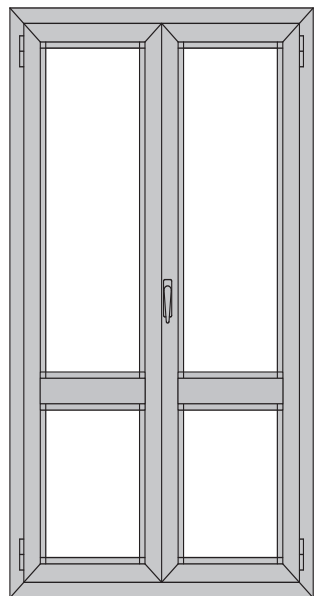

Art. Code	Descrizione Description	Qt.
AWX.19.SQ	Squadretta Telaio /Anta Frame/door corner connection	12
ARX.03.SQ	Squad. Cianfrinare EXT. External riveting corner joint	12
ARX.10.SQ	Squad. Allin. Anta INT. Internal door aligning corner joint	8
ARX.15.SQ	Squad. Allin. Telaio/Anta Frame/door aligning corner joint	12
ACX.02.01	Cerniera 2 Ali 2-leafed hinge	6
ARX.03.06	Cremonese Pressofusa Die-cast Cremonese bolt	1
ACX.03.14	Ferrogliera Striker plate	2
ACX.03.17	Innesti Cremonese Cremonese bolt connections	1
ACX.03.18	Terminale Astina Bar Terminal	2
ACX.03.71	Paletto mini TEX mini TEX lever bolt	2
ACX.04.51	Tappo Riporto Centrale Central wing cap	1
ARX.05.01	Copriaccola Scarico Acqua Water drainage slot cover	2
ARX.06.01	Espansore Expander	*
ACX.07.02	Angolo Pressofuso Fermavetro Die-cast glazing bead corner	16
ACX.10.04	Guarnizione Battuta Rabbet window gasket	4H-2L
ARX.10.05.1	Guarnizione Vetro EXT External glass window gasket	4H-4L
*ARX.10.XX	Guarnizione Vetro INT Internal glass window gasket	4H-4L
ARX.10.61	Guarnizione Precamera Prechamber Gasket	3H-2L
ARX.10.62	Angolo per Guarnizione centrale di Precamera ARX.10.61 Corner for pre-chamber central window gasket ARX.10.61	4
ARX.10.73	Guarnizione sotto vetro Gasket under glass	4H-4L

* Secondo Dimensioni | Depending on size

DISTINTA Taglio Vetri | Glass Cutting List

Qt.	H	L
1	H - H _{Fa} - 58	L/2 - 130.5
2	H _{Fa} - 154	L/2 - 130.5

Spazio/Gap 5 mm.

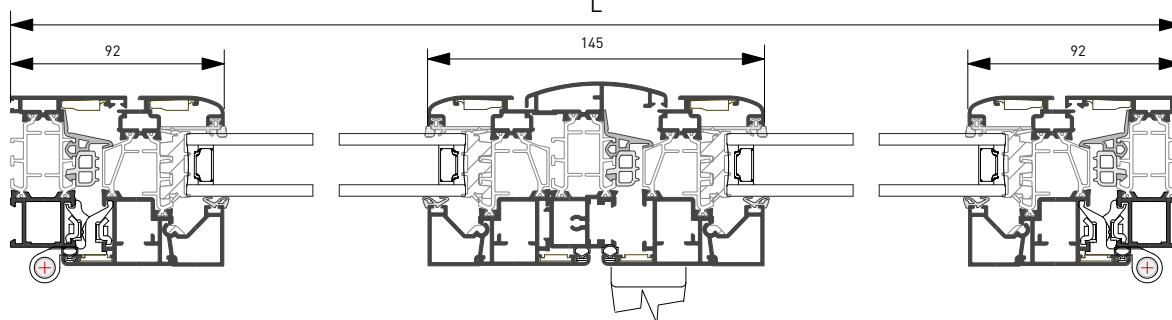
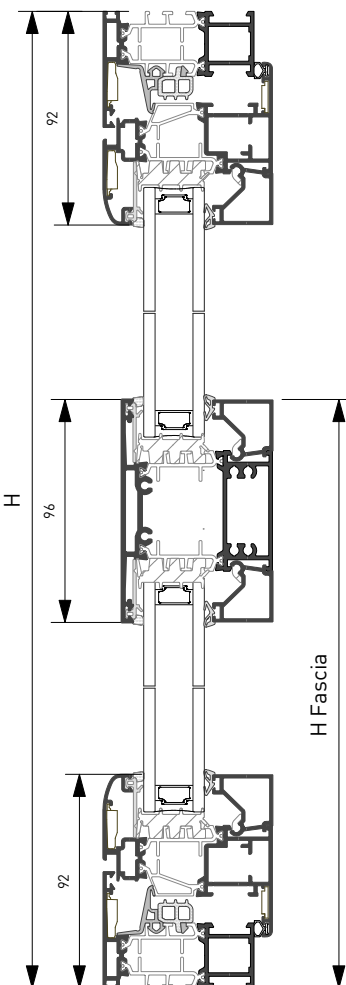

Profilo Profile	Taglio CUT	Qt.	Profilo Profile	Taglio CUT	Qt.	Profilo Profile	Taglio CUT	Qt.
CX65.101	L	2	CX70.565	L/2 - 164.5	8	CX65.301	H - 110	1
	H	2		H - H _{Fa} - 92	4			
CX65.201	L/2 - 24.5	4		H _{Fa} - 188	4	CX65.402	L/2 - 110.5	2
	H - 44	2	CX70.605		1			



Attacco alla Muratura
Connection to Brickwork

Gruppo F

Sezione particolareggiata
attacco alla muratura

Wall Joint Detail

SCHEMA FISSAGGIO | Fixing

Tipo A | Type A

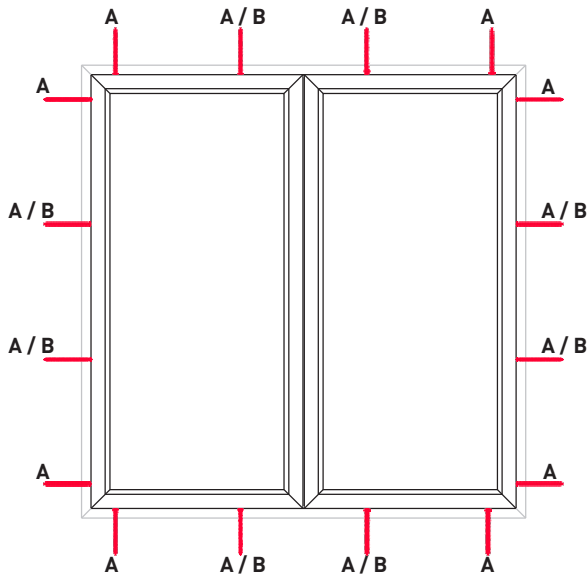

DAGLI ANGOLI | From the CORNERS = 150 mm.

INTERASSE | Center Distance = 700 mm.

FISSAGGI MINIMI | Minimum Fasteners = 8 Fasteners

Verticale = 3 Fissaggi /Lato | Vertical = 3 Fasteners/ Side
Orizzontale = 1 Fissaggio/Lato | Horizontal = Fasteners/Side

ARX.06.13 REGISTRO TELAIO TWIN AUTOBLOCCANTE SU ALLUMINIO
TWIN frame register self-Locking on profiles

PUNTA 2 DIAMETRI

Tip 2 diameters

LAMATORE

LAMATOR

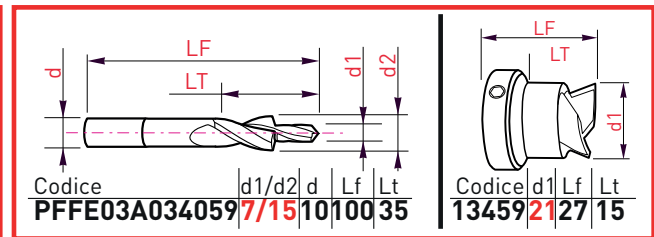
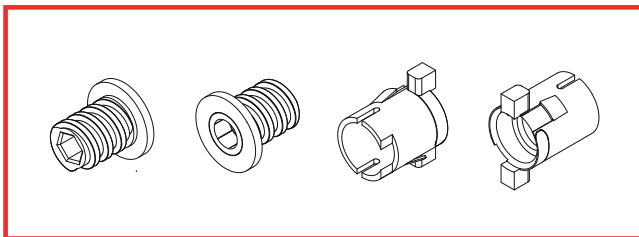

ARX.06.14/15 REGISTRO TELAIO TWIN AUTOBLOCCANTE SU BARRETTE DI POLIAMMIDE
TWIN frame register self-Locking on Polyamide bars

LAMATORE

LAMATOR

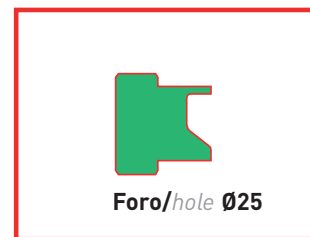
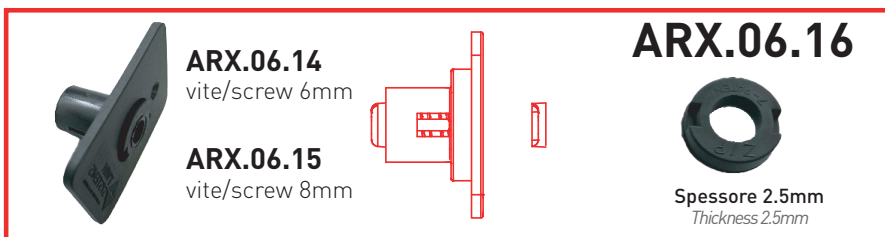

PUNTA RP019 a 2 DIAMETRI per articolo ARX.06.14
Tip RP019 with 2 diameters for ARX.06.14

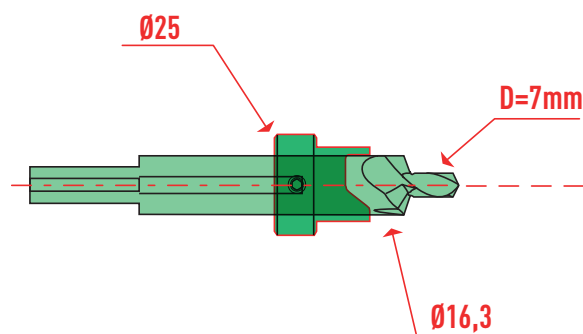

PUNTA RP040 a 2 DIAMETRI per articolo ARX.06.15
Tip RP040 with 2 diameters for ARX.06.15

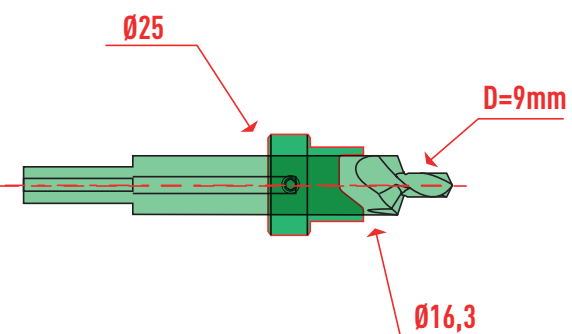



FISSAGGIO ALLA MURATURA
Fixing to the wall

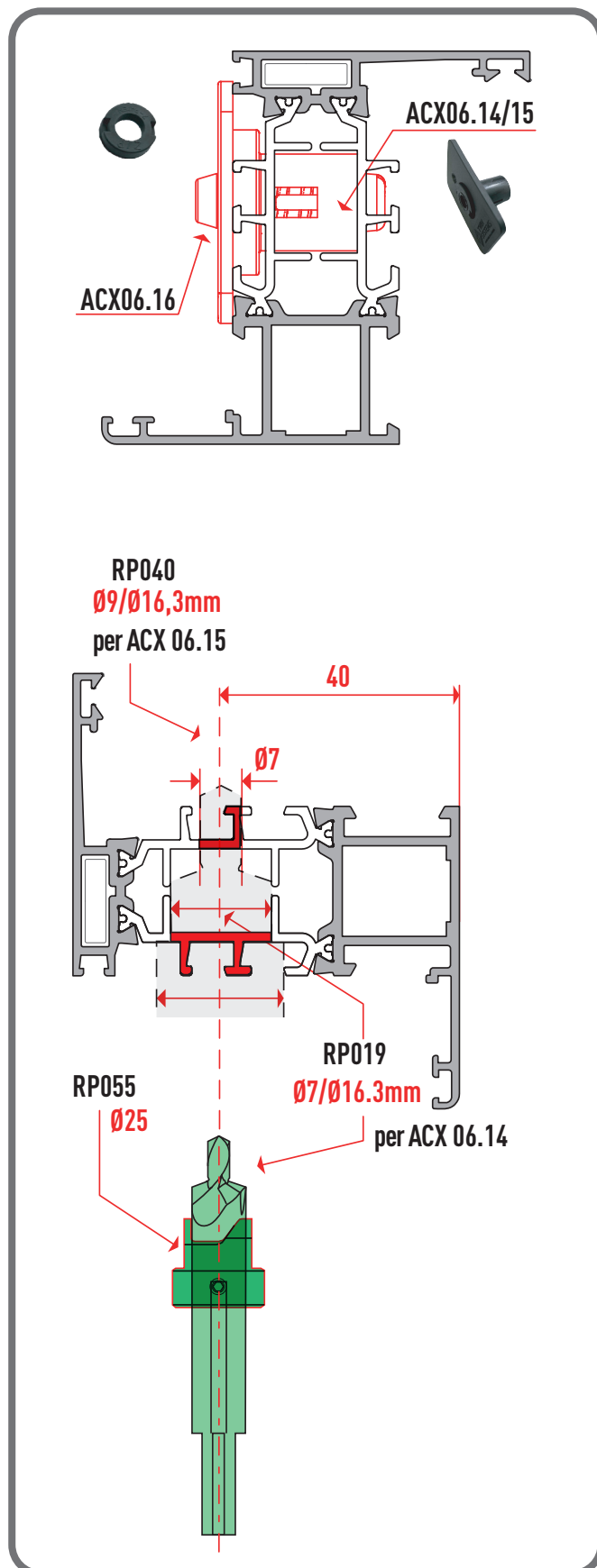
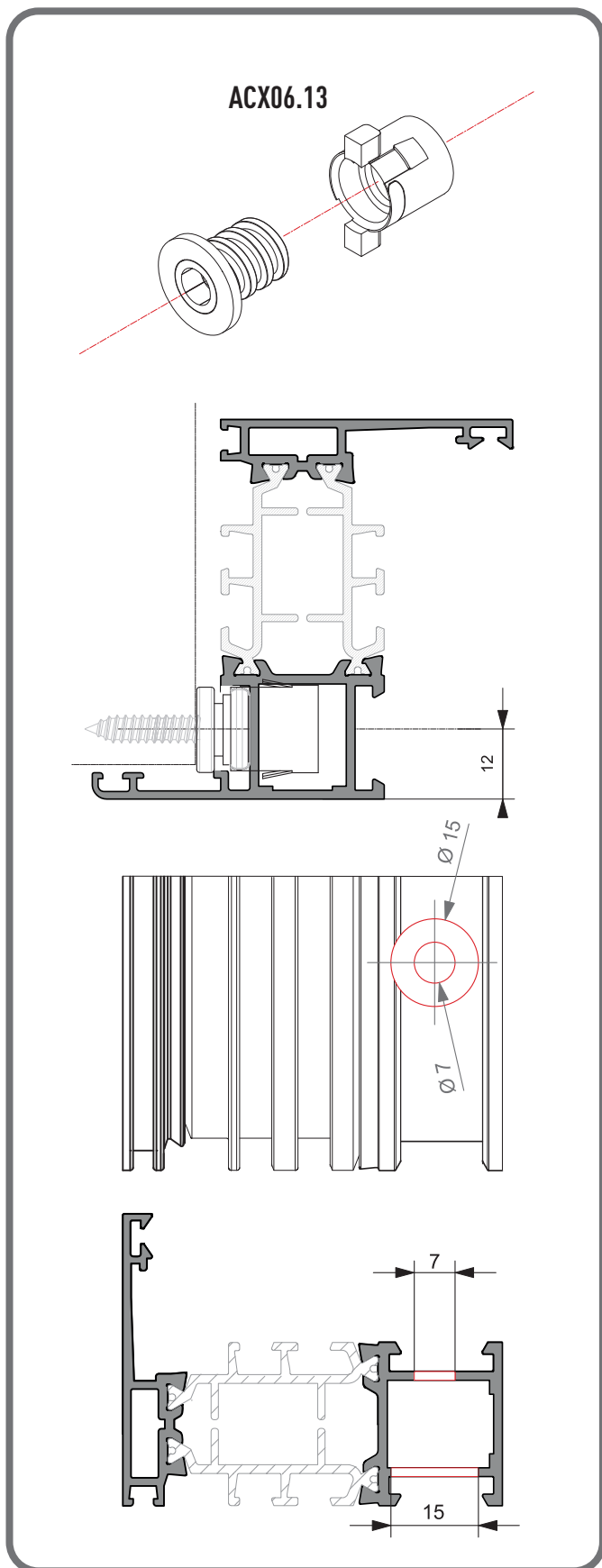



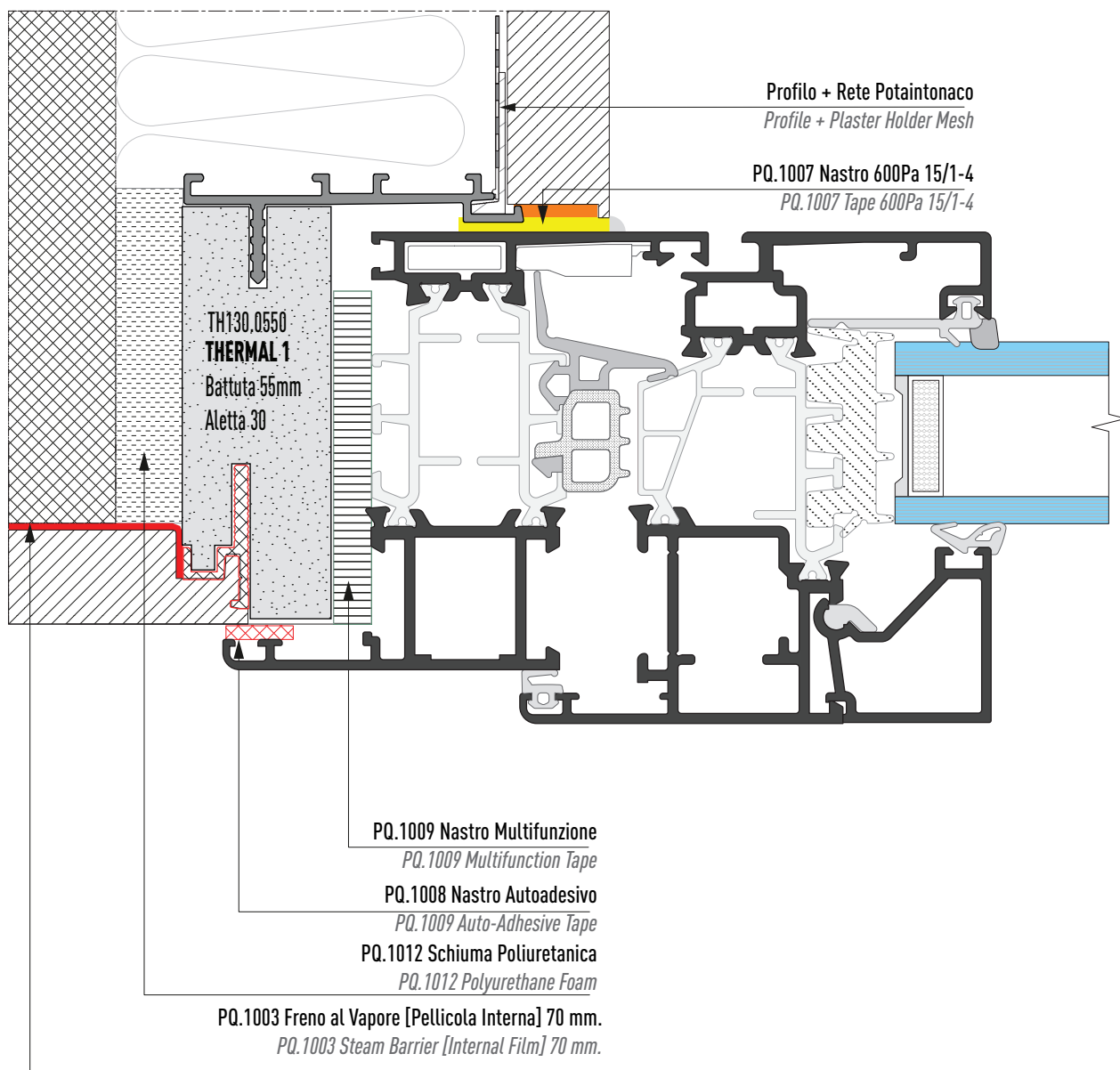

SEZIONE ORIZZONTALE
Horizontal Section

POSA QUALITÀ

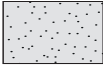
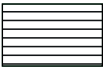
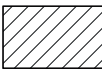
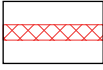

LEGENDA MATERIALI

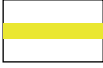
Material legend

	Muratura <i>Brickwall</i>		Controtelaio THERMAL <i>Wall frame THERMAL</i>		PQ.1012 Schiuma Poliuretanic <i>PQ.1012 Polyurethane Foam</i>
	Intonaco <i>Plaster</i>		PQ.1008 Nastro Autoadesivo 9x2 <i>PQ.1008 Auto-Adhesive Tape 9x2</i>		PQ.1003 Freno al Vapore [Pellicola Interna] 70 mm. <i>PQ.1003 Steam Barrier [Internal Film] 70 mm.</i>
	Isolamento <i>Insulation</i>		PQ.1007 Nastro 600Pa 15/1-4 <i>PQ.1007 Tape 600Pa 15/1-4</i>		Sigillante Ibrido <i>Hybrid Sealant</i>

SEZIONE VERTICALE

Vertical Section



LEGENDA MATERIALI

Material legend

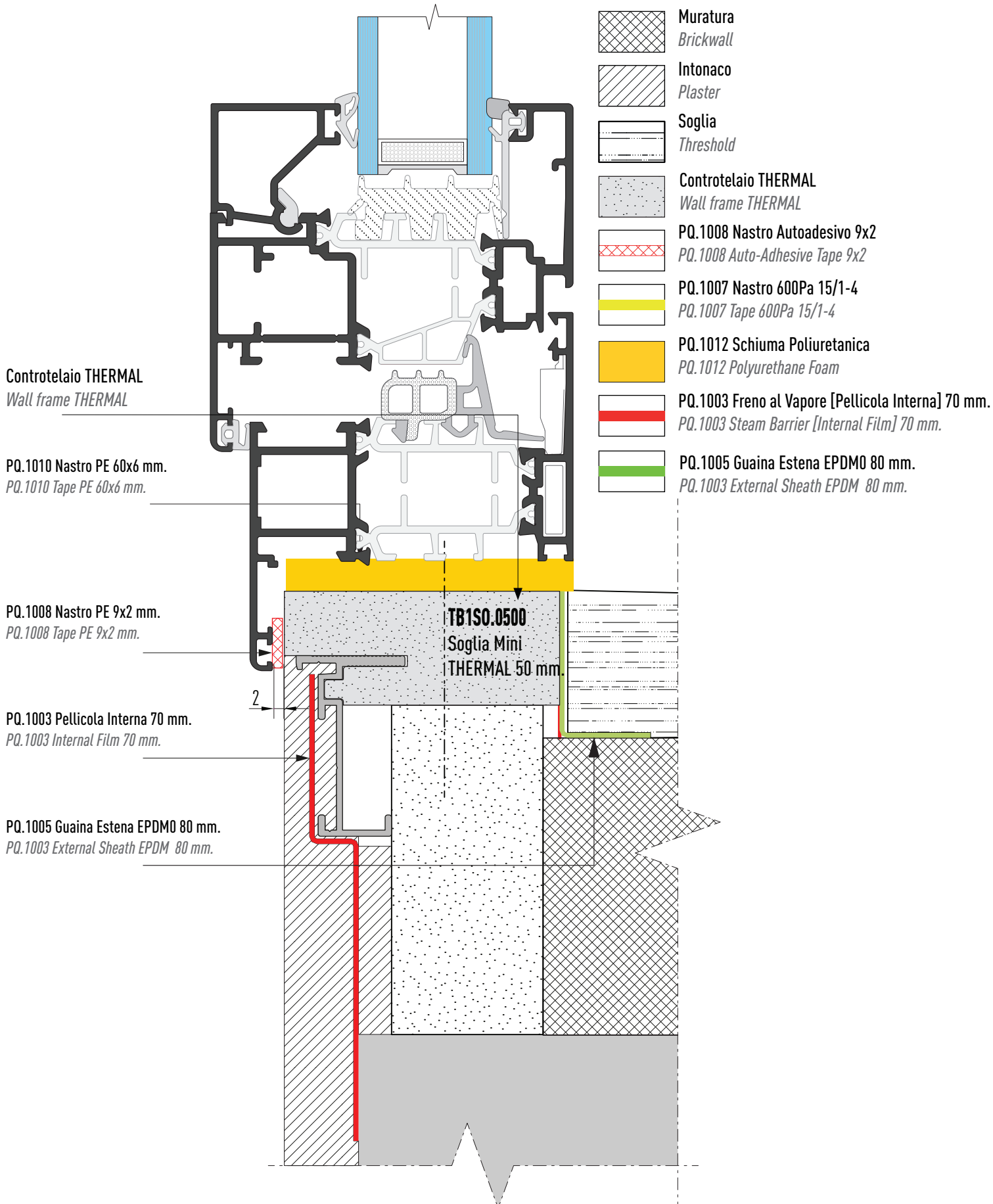



► **CONTROTELAIO PERIMETRALE**
PERIMETRAL COUNTERFRAME

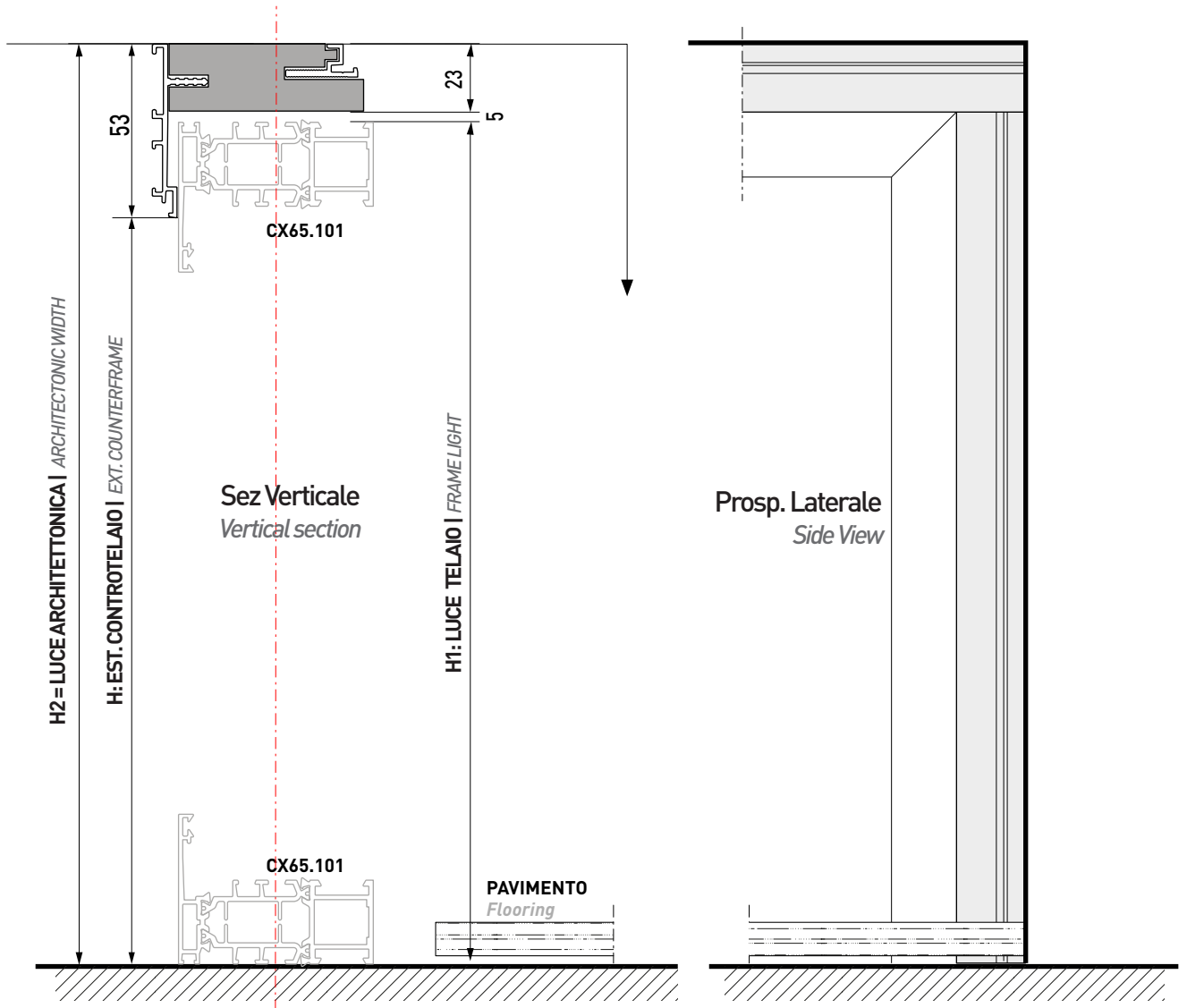
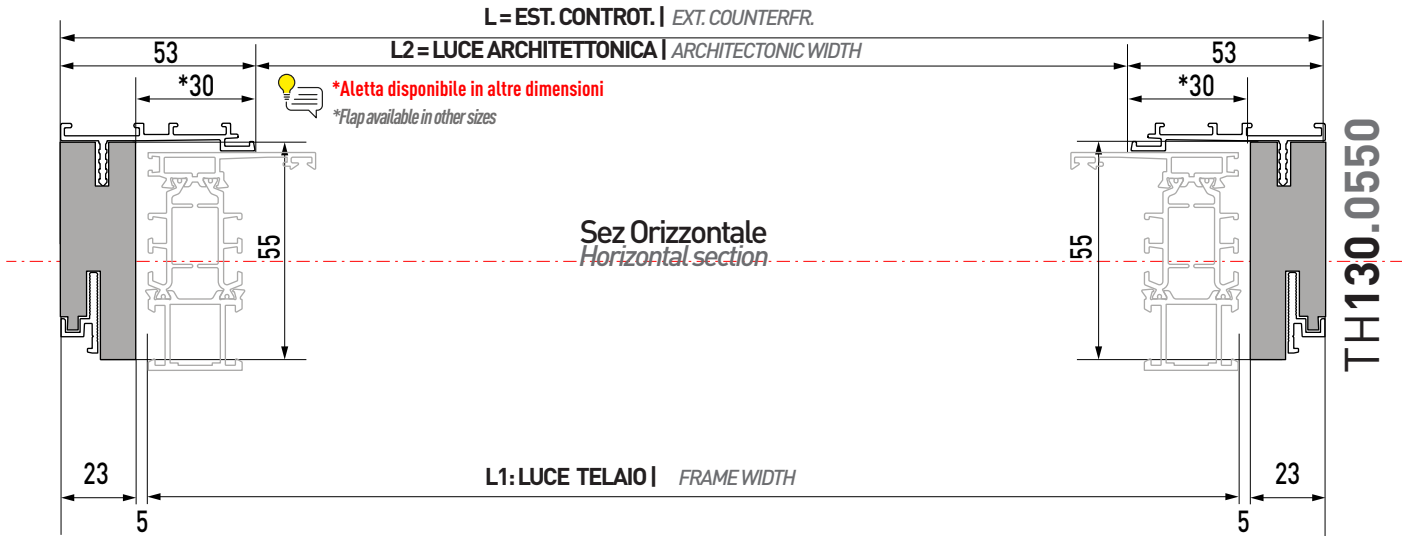



Lavorazioni e Montaggi
Tooling and Assembly

Gruppo **G**

Schemi Lavorazioni
Frese
Attrezzatura

*Tooling Systems
Cutters Equipments
Milling*

Pressette

Mills

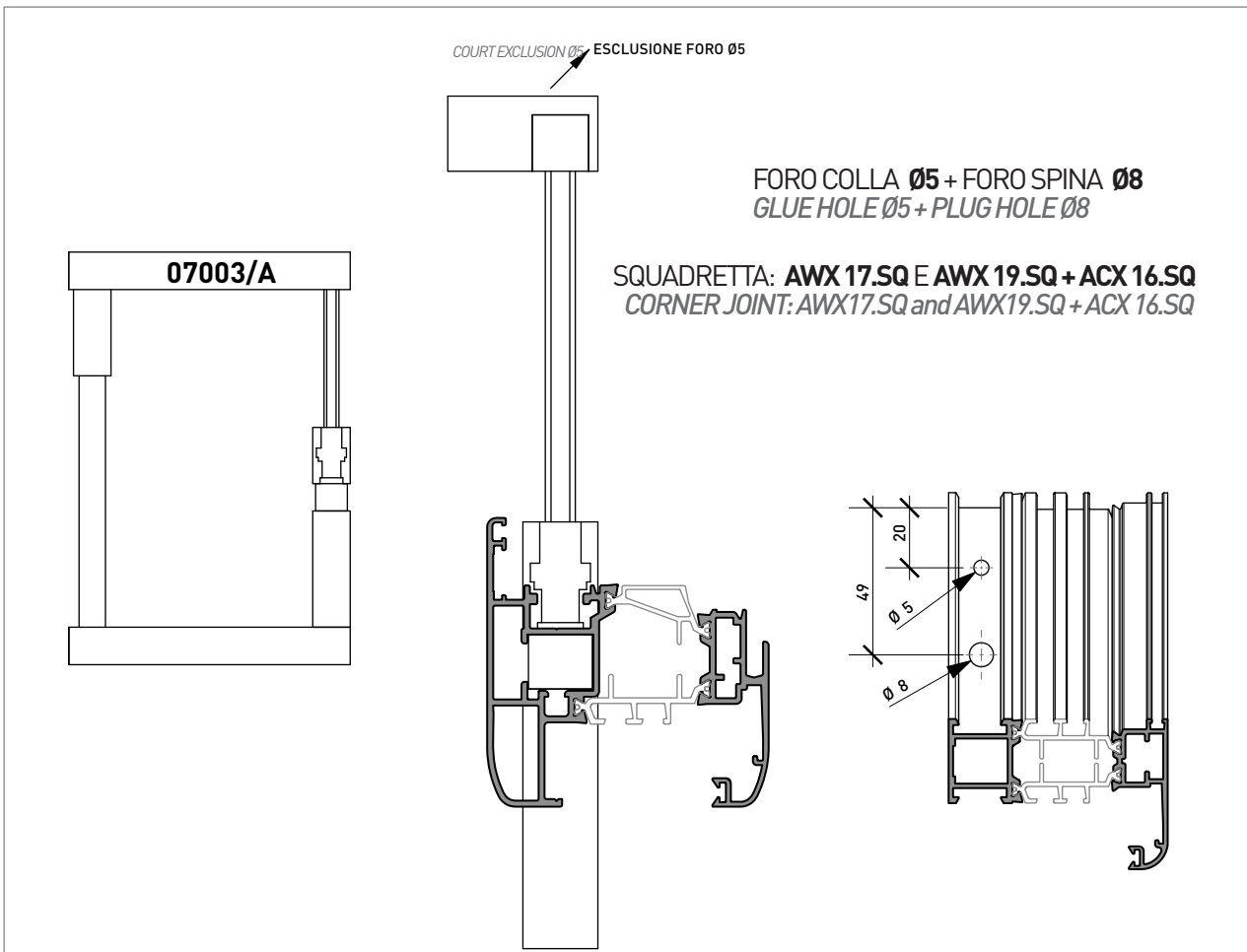
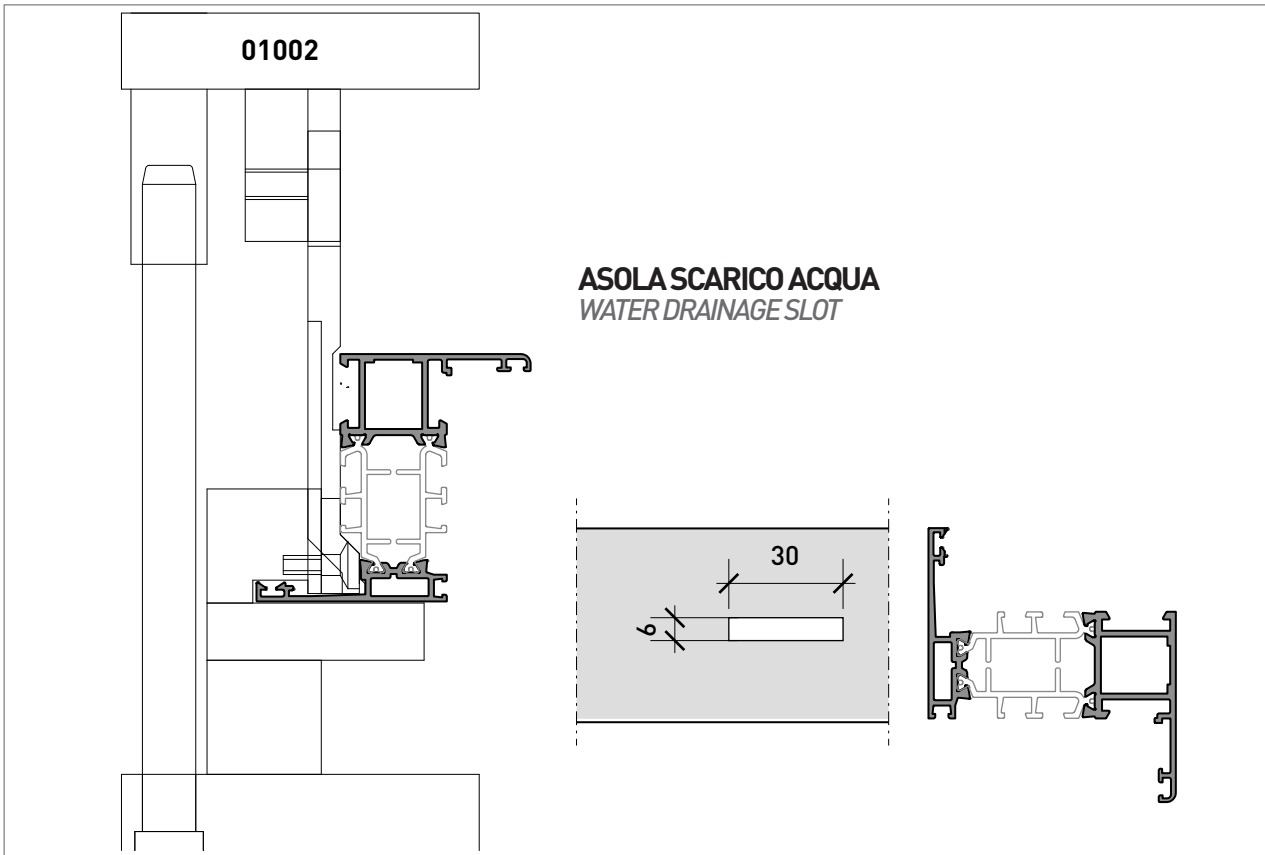

***SONO IDONEI ANCHE CODICI RELATIVI AD AGGIORNAMENTI SUCCESSIVI ("X") | Codes related to subsequent updates are also suitable. ("X").**

Quanto illustrato in questo catalogo è riservato e, a termini di legge, ne è vietata la riproduzione, anche parziale, se non esplicitamente autorizzata.
As illustrated in this catalog is reserved and, by law, is prohibited reproduction, even partial, if not expressly authorized.

Pressette

Mills

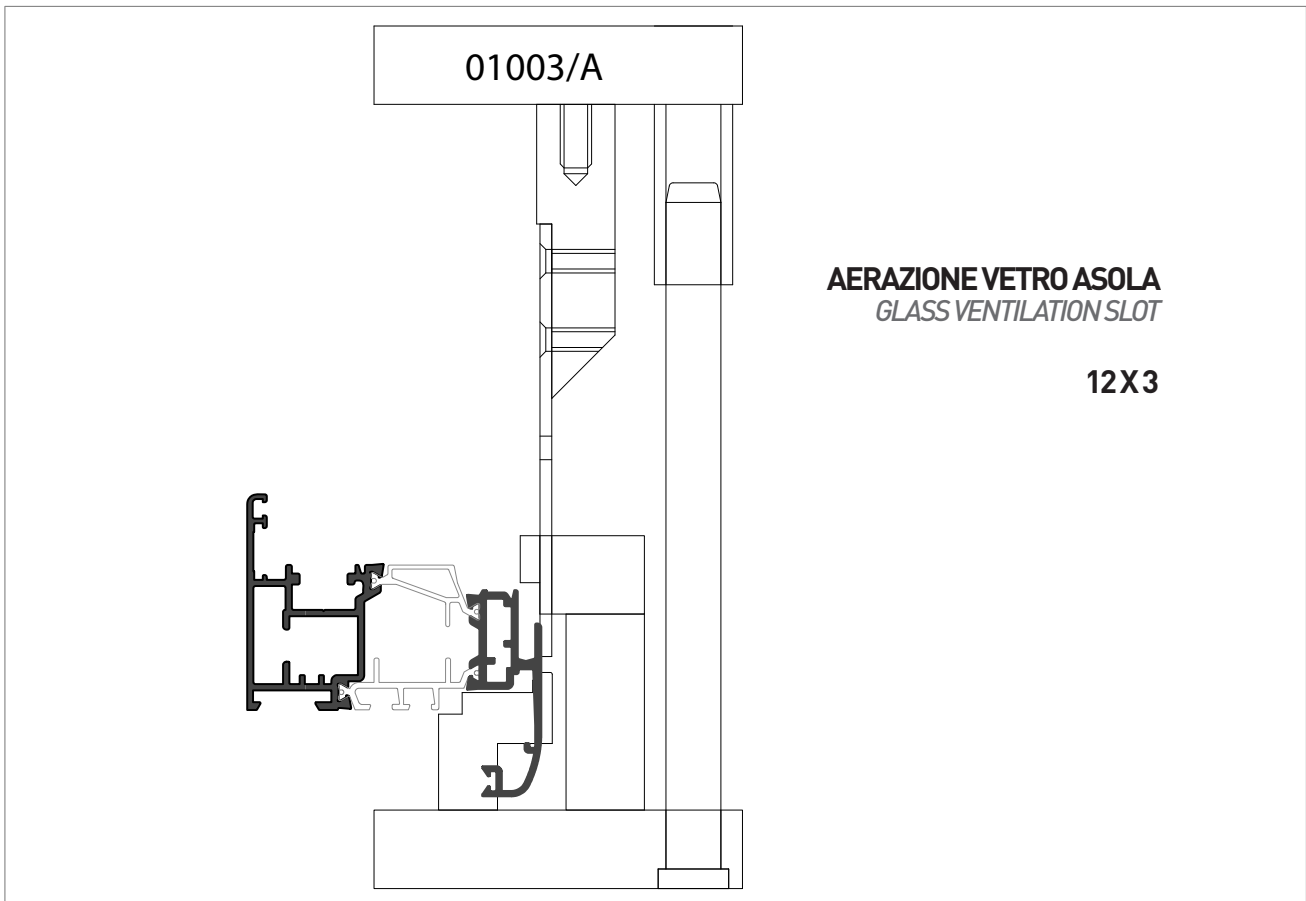
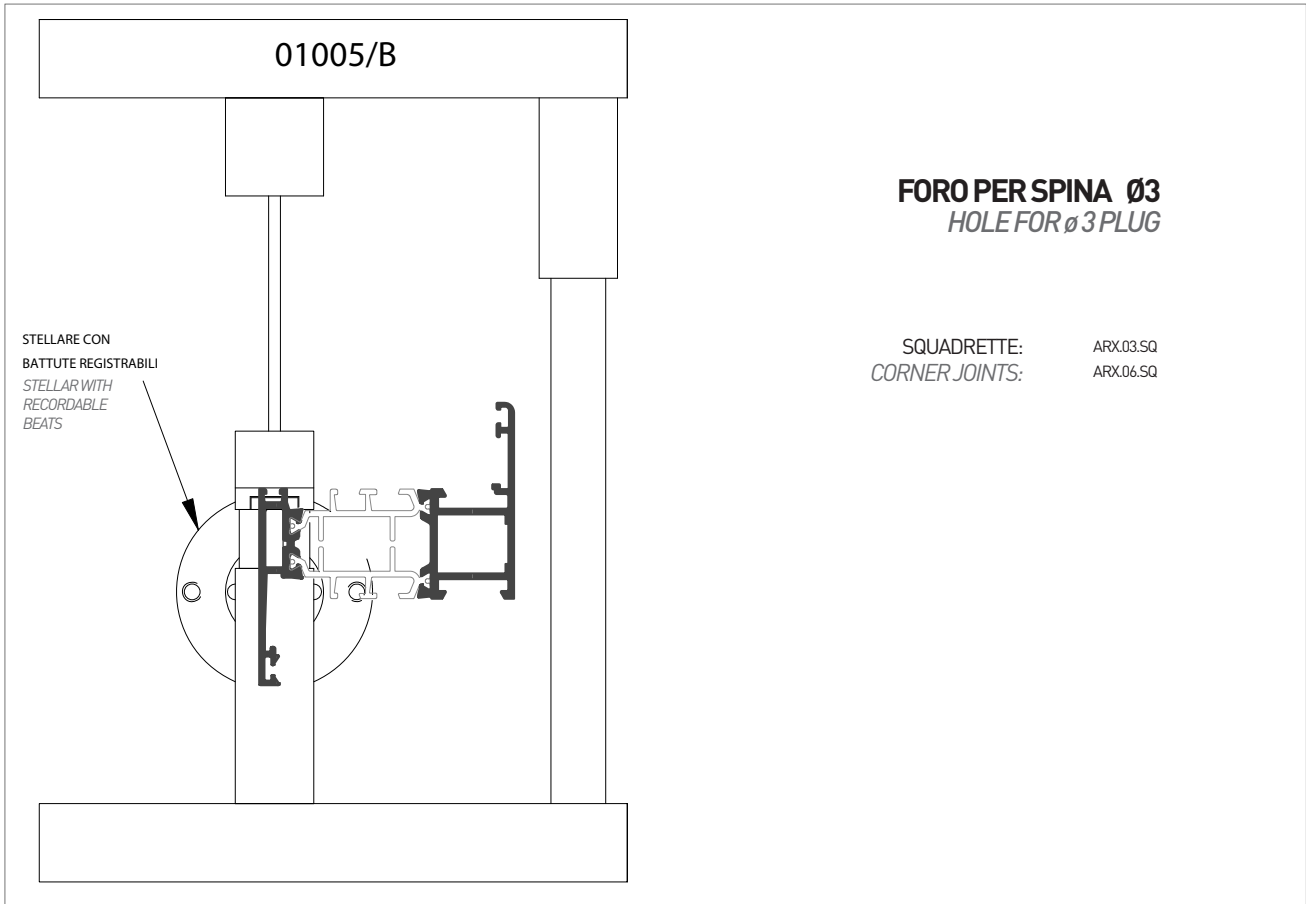

***SONO IDONEI ANCHE CODICI RELATIVI AD AGGIORNAMENTI SUCCESSIVI ("X") | Codes related to subsequent updates are also suitable. ("X").**

Quanto illustrato in questo catalogo è riservato e, a termini di legge, ne è vietata la riproduzione, anche parziale, se non esplicitamente autorizzata.
As illustrated in this catalog is reserved and, by law, is prohibited reproduction, even partial, if not expressly authorized.

Pressette

Mills

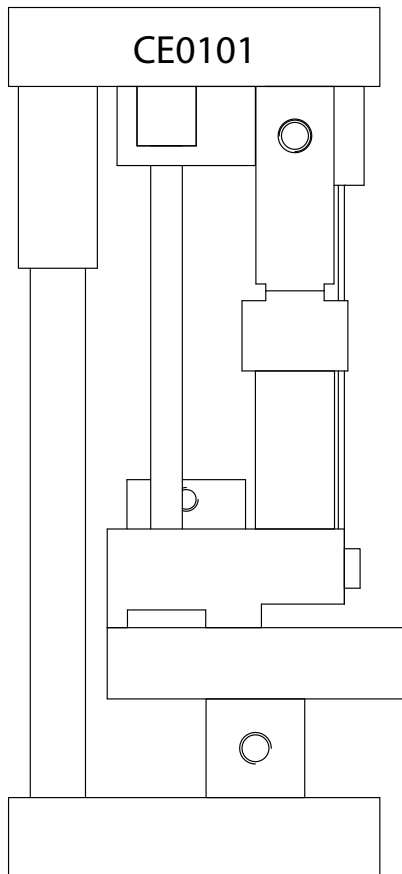

LAVORAZIONI
TOOLING

- LAVORAZIONE CREMONESE DA 104 mm
- CREMONESE BOLT TOOLING 104mm
- FORO Ø8 DI TESTA E PASSANTE, DOPPIO FORO DA Ø8 SU ASTINA
- Ø8 HEAD AND THROUGH HOLE, DOUBLE Ø8 HOLE ON BAR
- ASPORTAZIONE DENTINI PASSAGGIO ASTA
- REMOVAL OF BAR PASSING TEETH

ESCLUSORE PER DOPPIO FORO ASTINA
EXCLUDER FOR DOUBLE BAR HOLE

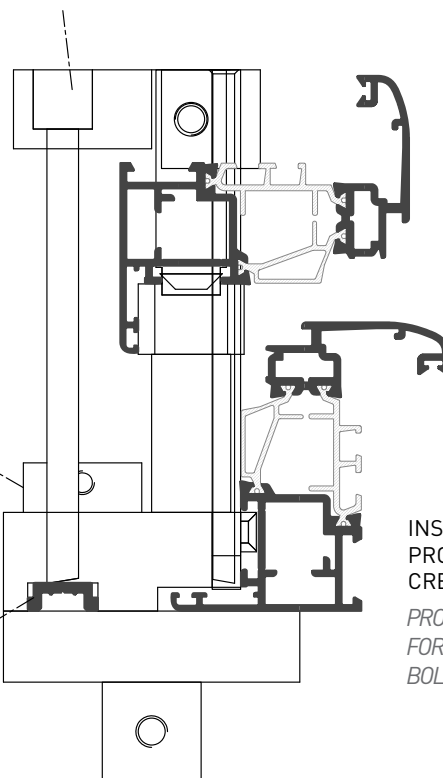

INSERIMENTO
PROFILO PER
SPIZZATURA
*INSERTION OF
PROFILE FOR
V-CUTTING*

BATTUTA PER FORATURA
DI TESTA ASTINA
*DOOR STOP FOR BAR
HEAD DRILLING*

INSERIMENTO ASTINA
BAR INSERTION

INSERIMENTO
PROFILO PER
CREMONESE
*PROFILE INSERTION
FOR CREMONESE
BOLT*

***SONO IDONEI ANCHE CODICI RELATIVI AD AGGIORNAMENTI SUCCESSIVI ("X") | Codes related to subsequent updates are also suitable. ("X").**

Quanto illustrato in questo catalogo è riservato e, a termini di legge, ne è vietata la riproduzione, anche parziale, se non esplicitamente autorizzata.
As illustrated in this catalog is reserved and, by law, is prohibited reproduction, even partial, if not expressly authorized.

Pressette

Mills

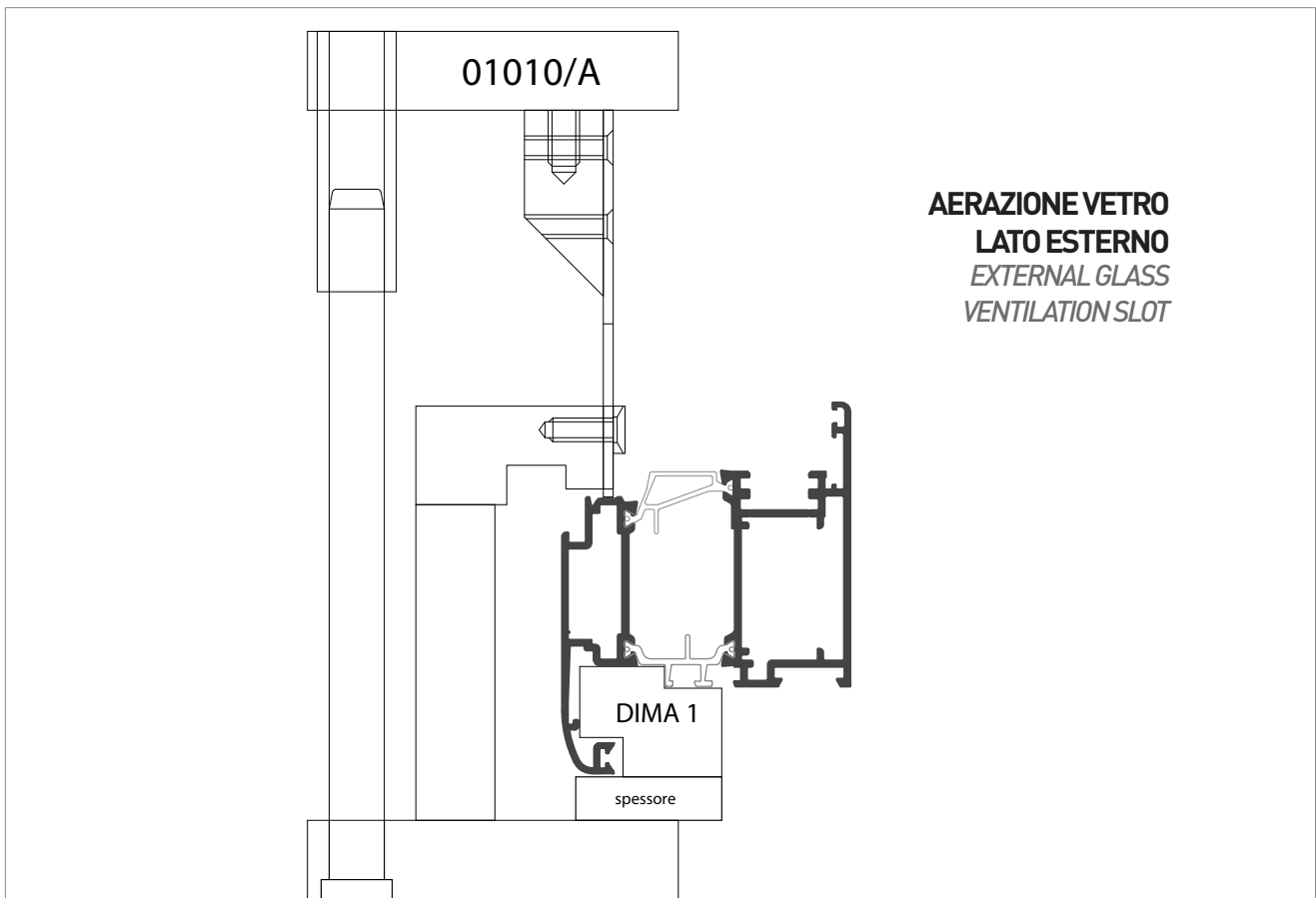
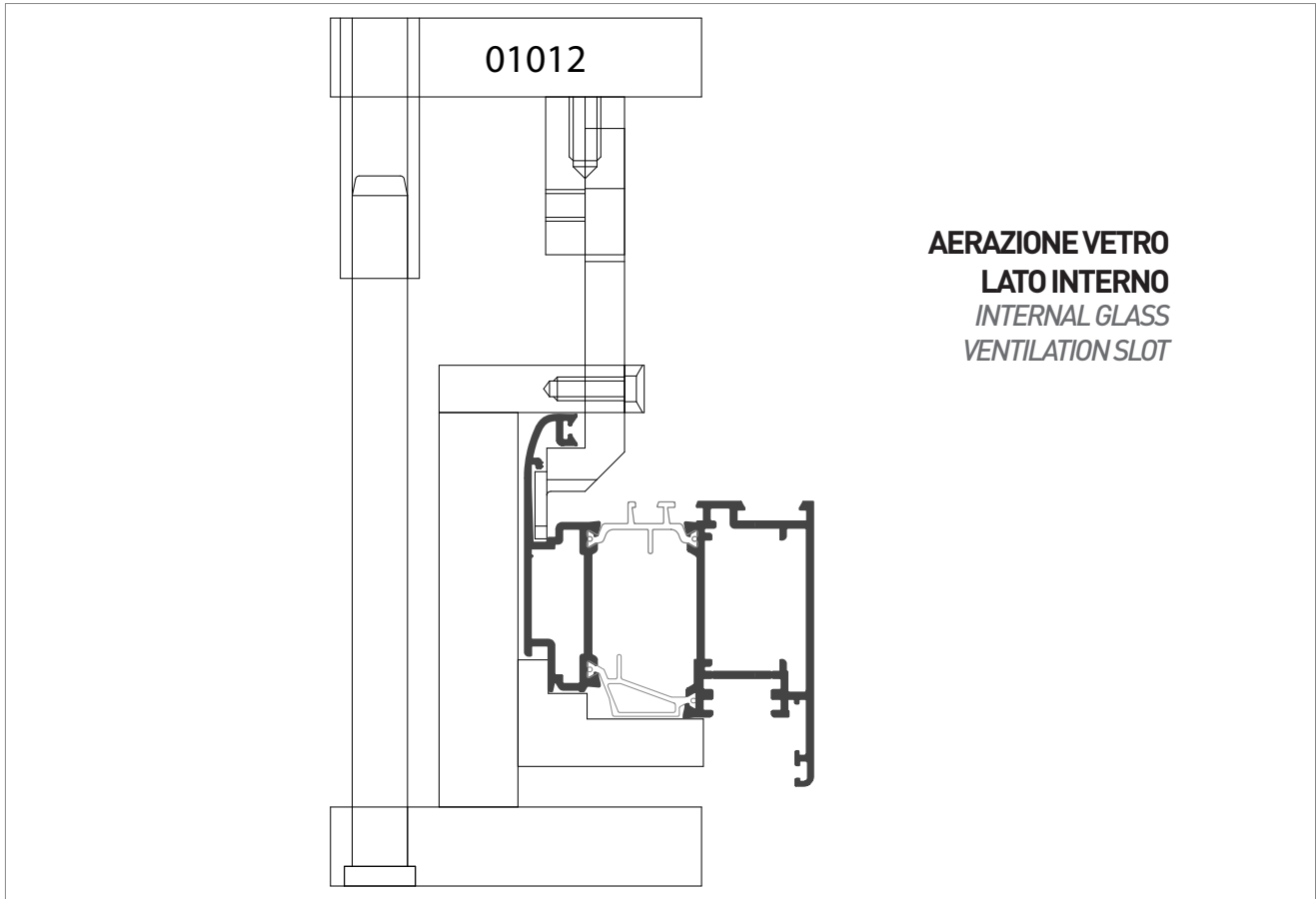

***SONO IDONEI ANCHE CODICI RELATIVI AD AGGIORNAMENTI SUCCESSIVI ("X") | Codes related to subsequent updates are also suitable. ("X").**

Quanto illustrato in questo catalogo è riservato e, a termini di legge, ne è vietata la riproduzione, anche parziale, se non esplicitamente autorizzata.
As illustrated in this catalog is reserved and, by law, is prohibited reproduction, even partial, if not expressly authorized.

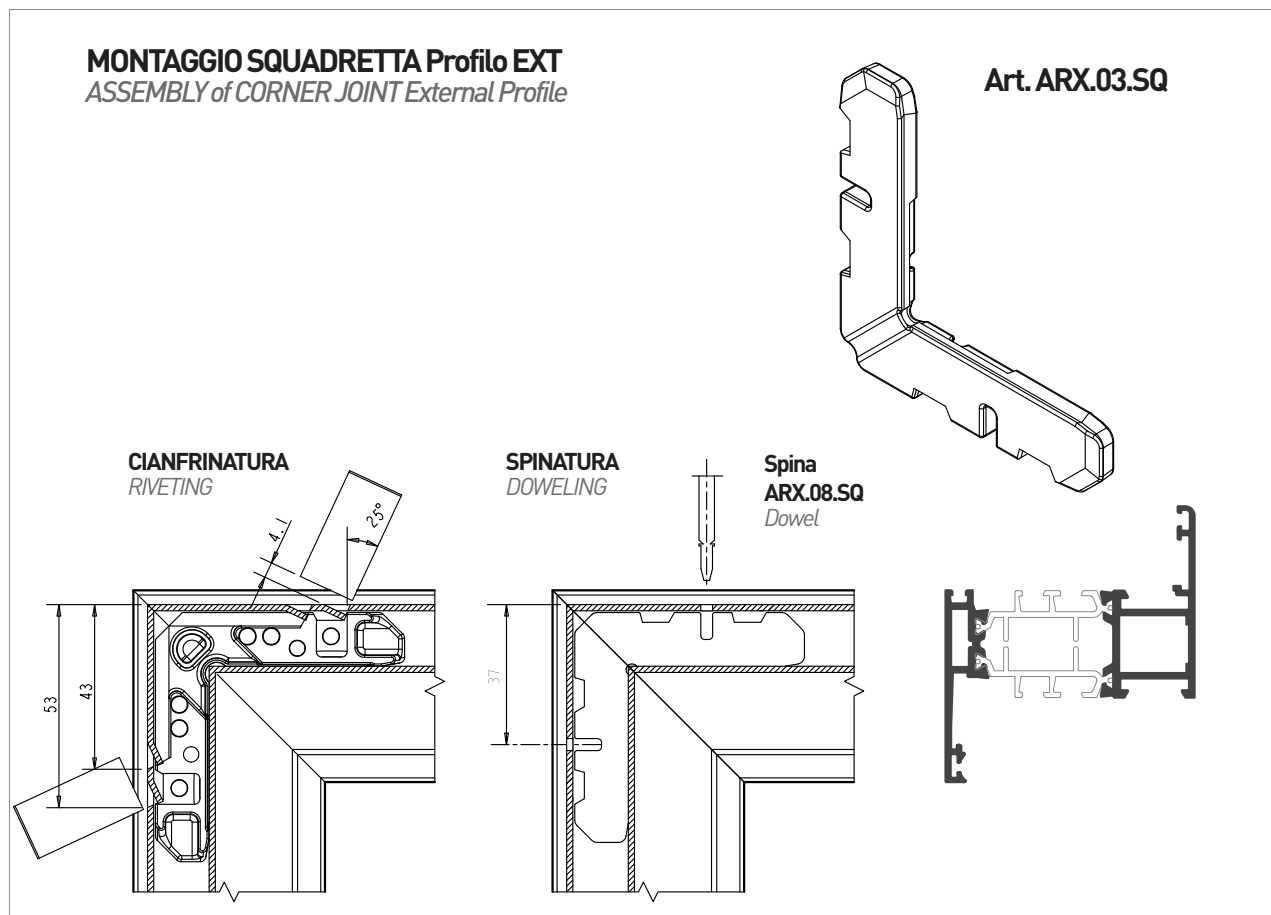
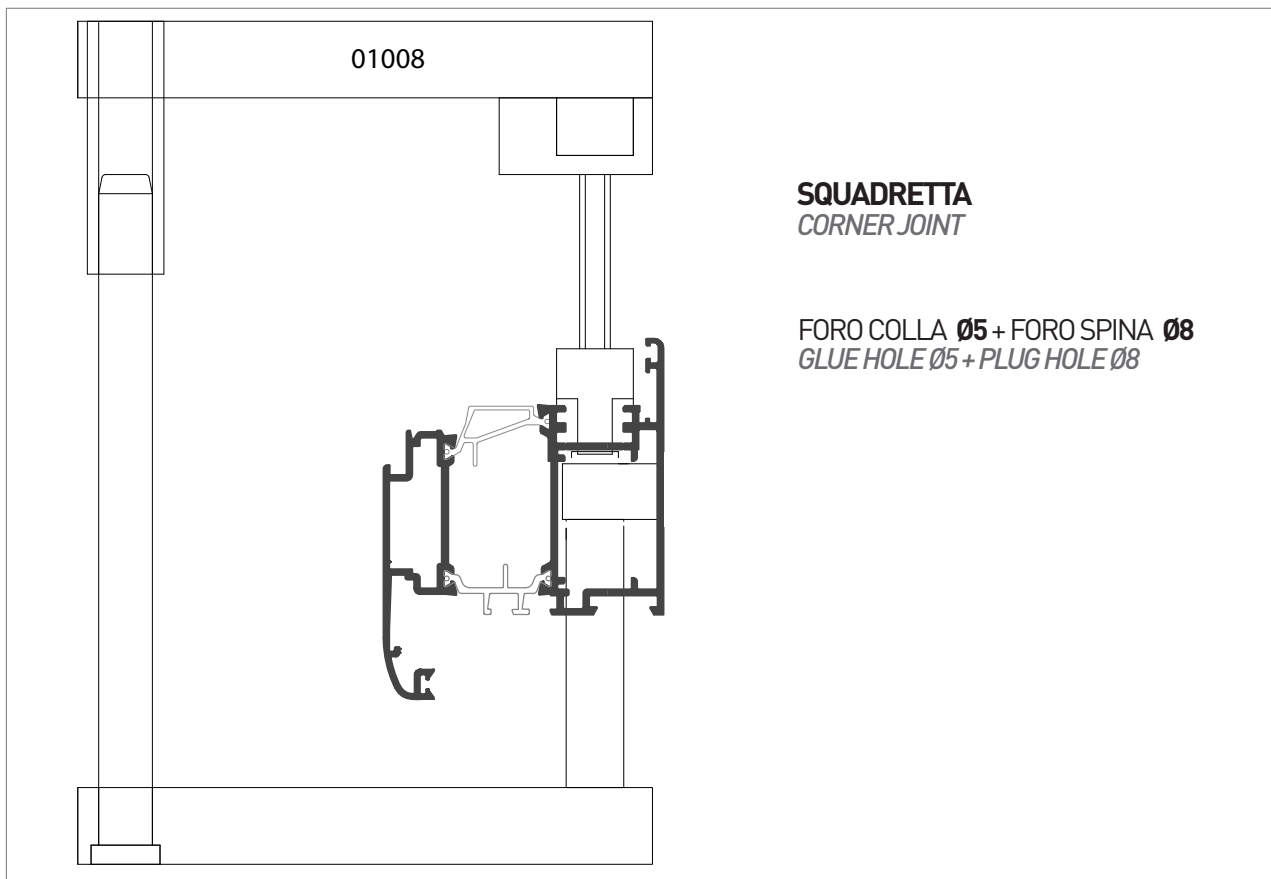

***SONO IDONEI ANCHE CODICI RELATIVI AD AGGIORNAMENTI SUCCESSIVI ("X") | Codes related to subsequent updates are also suitable. ("X").**

Quanto illustrato in questo catalogo è riservato e, a termini di legge, ne è vietata la riproduzione, anche parziale, se non esplicitamente autorizzata.
As illustrated in this catalog is reserved and, by law, is prohibited reproduction, even partial, if not expressly authorized.

Applicazione Accessori

Application of Accessories

CARICAVETRO
GLASS LOADER

ARX.06.13

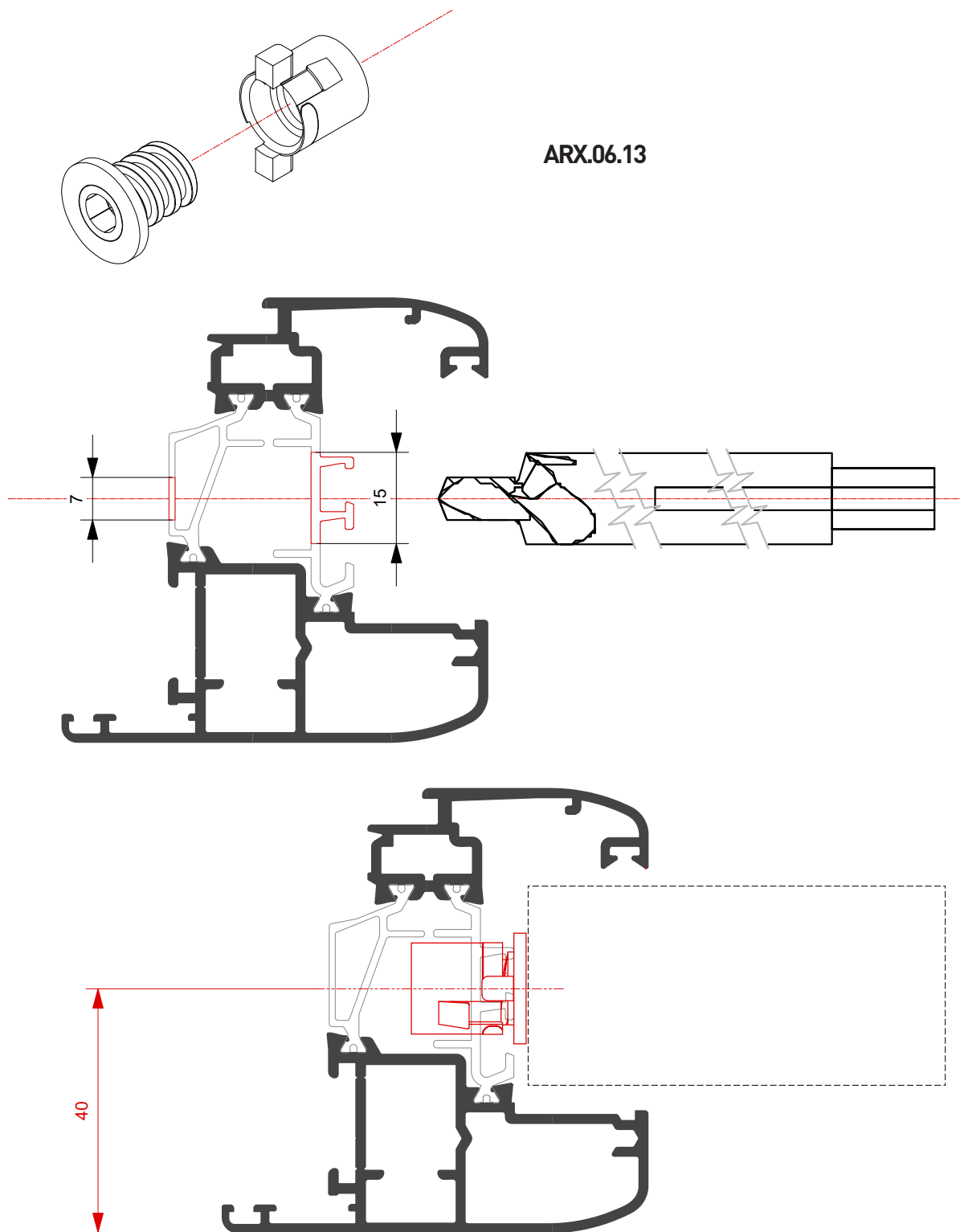

Applicazione Accessori

Application of Accessories

REGOLO in POLIAMMIDE su BARRETTA
SELF LOCKING SPACER ON POLYAMIDE

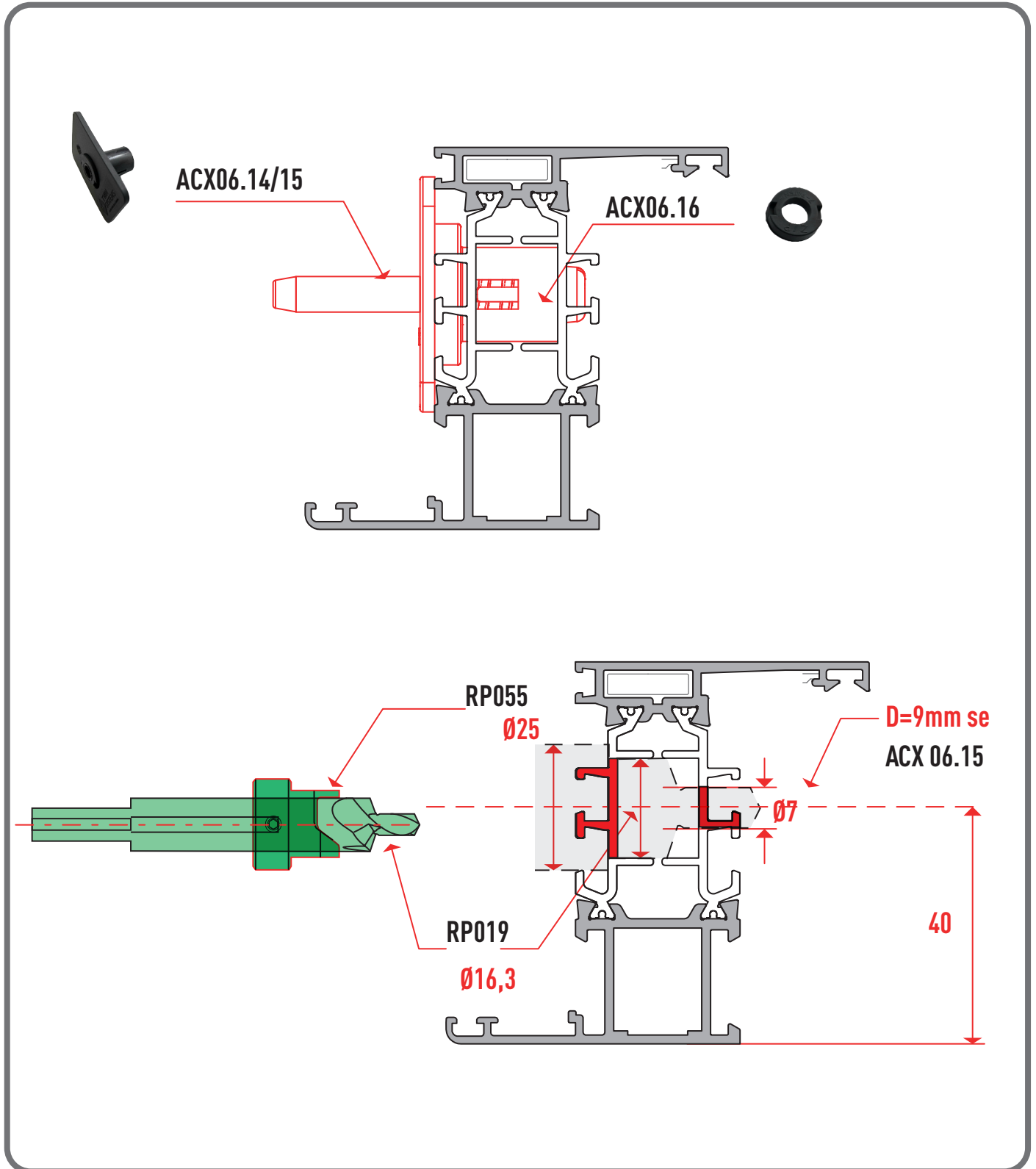

Applicazione Accessori

Application of Accessories

MONTAGGIO SQUADRETTA Profilo EXT
ASSEMBLY of CORNER JOINT External Profile

ARX.06.SQ

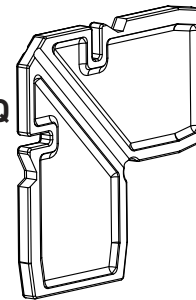

CIANFRINATURA
RIVETING

SPINATURA
DOWELING

Spina
ARX.08.SQ
Dowel

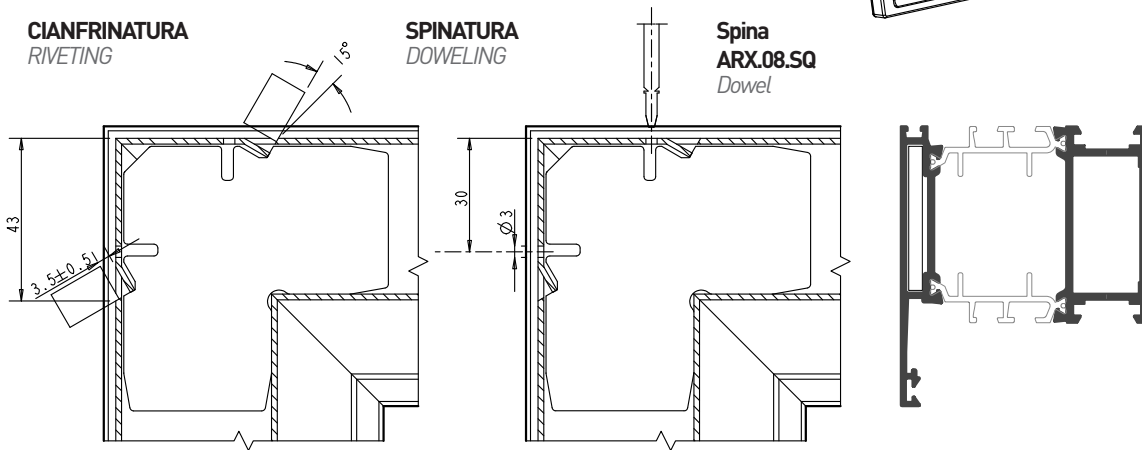

MONTAGGIO SQUADRETTA A PULSANTE Profilo INT
ASSEMBLY OF SLOT CORNER JOINT Internal Profile

ACX.16.SQ

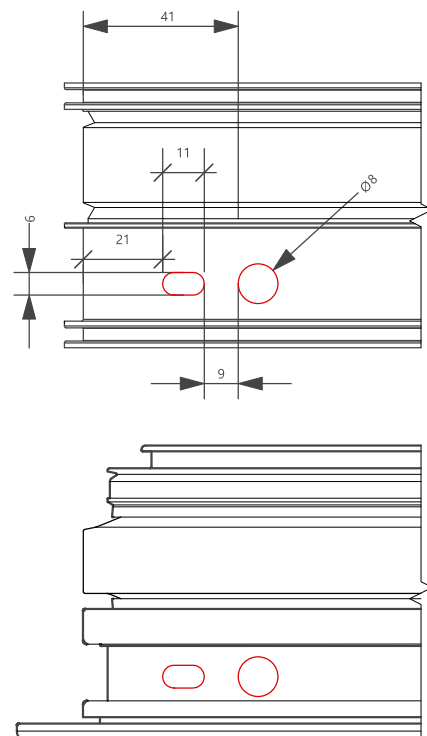
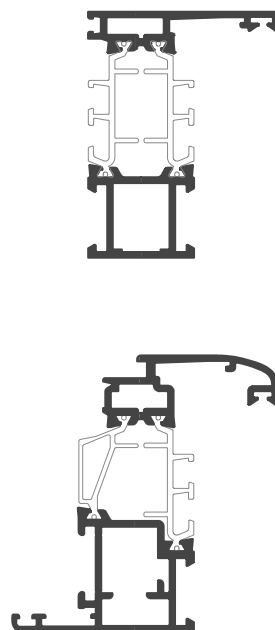
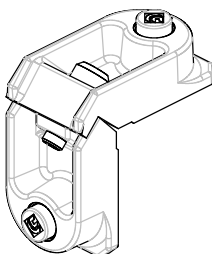

Applicazione Accessori

Application of Accessories

MONTAGGIO SQUADRETTA SPINARE, CIANFRINARE ED AVVITARE

ASSEMBLY of CORNER JOINT DOWELING, RIVETING, TIGHTENING

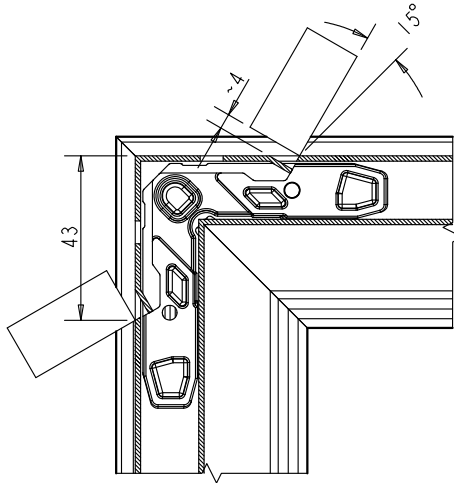

CIANFRINATURA Coltello 10 mm
RIVETING Knife 10 mm

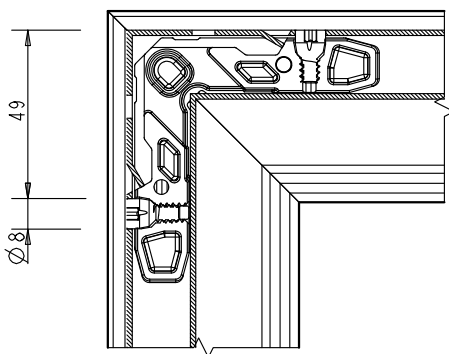

AVVITATURA VIL M5X14_D8
TIGHTENING VIL M5X14_D8

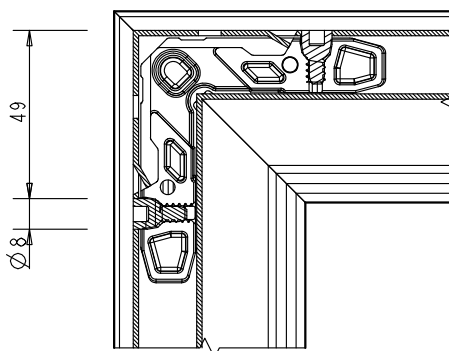

SPINATURA
SPINA ARX.07.SQ [LM0088]
DOWELING
DOWEL ARX.07.SQ
[LM0088] M5X14_D8

Art. AWX.19.SQ

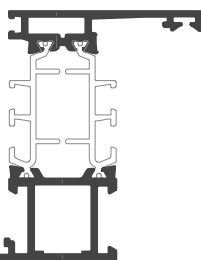
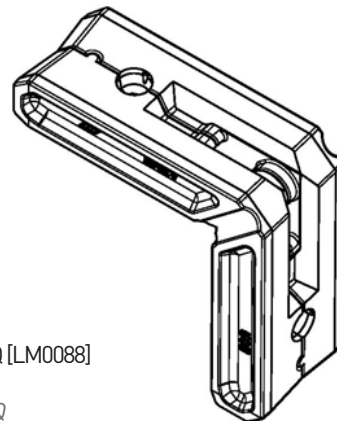

Applicazione Accessori

Application of Accessories

MONTAGGIO SQUADRETTA SPINARE, CIANFRINARE ED AVITARE

ASSEMBLY of CORNER JOINT DOWELING, RIVETING, TIGHTENING

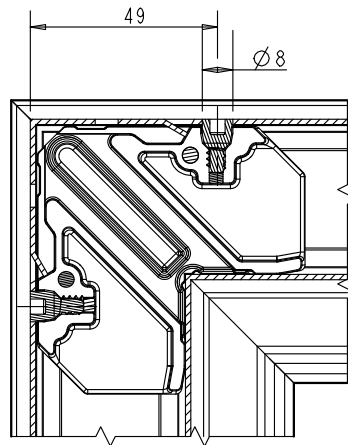

SPINATURA

SPINA ARX.07.SQ [LM0088]

DOWELING

DOWEL ARX.07.SQ [LM0088] M5X14_D8

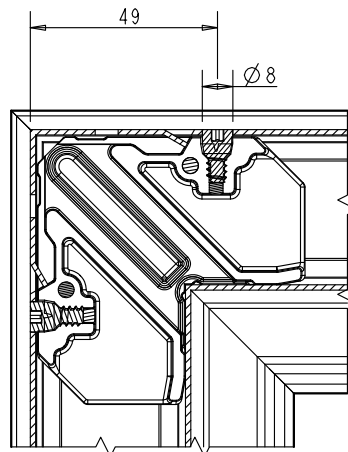

AVITATURA VIL M5X14_D8

TIGHTENING VIL M5X14_D8

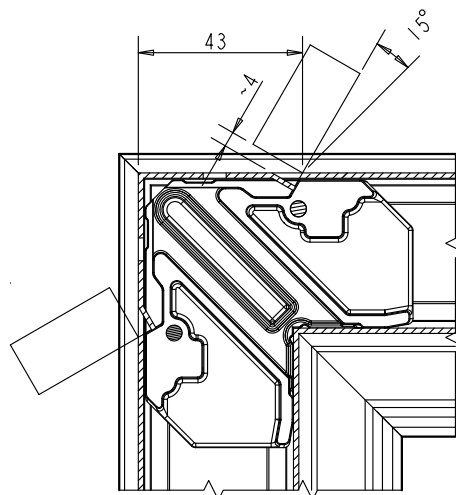

CIANFRINATURA Coltello 10 mm

RIVETING Knife 10 mm

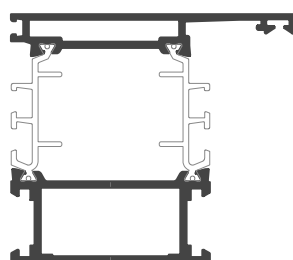

Art. AWX.17.SQ

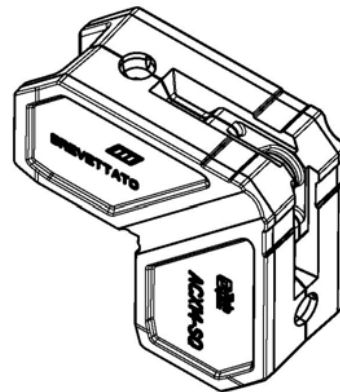

Applicazione Accessori

Application of Accessories

ACX.63.SQ
GIUNZIONE A "T" O A "CROCE"
"T" OR "CROSS" JOINT

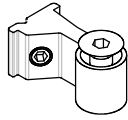

ACX.64.SQ
GIUNZIONE A "T" O A "CROCE"
PER PROFILI MAGGIORATI
*"T" OR "CROSS" JOINT
FOR OVERSIZE PROFILES*

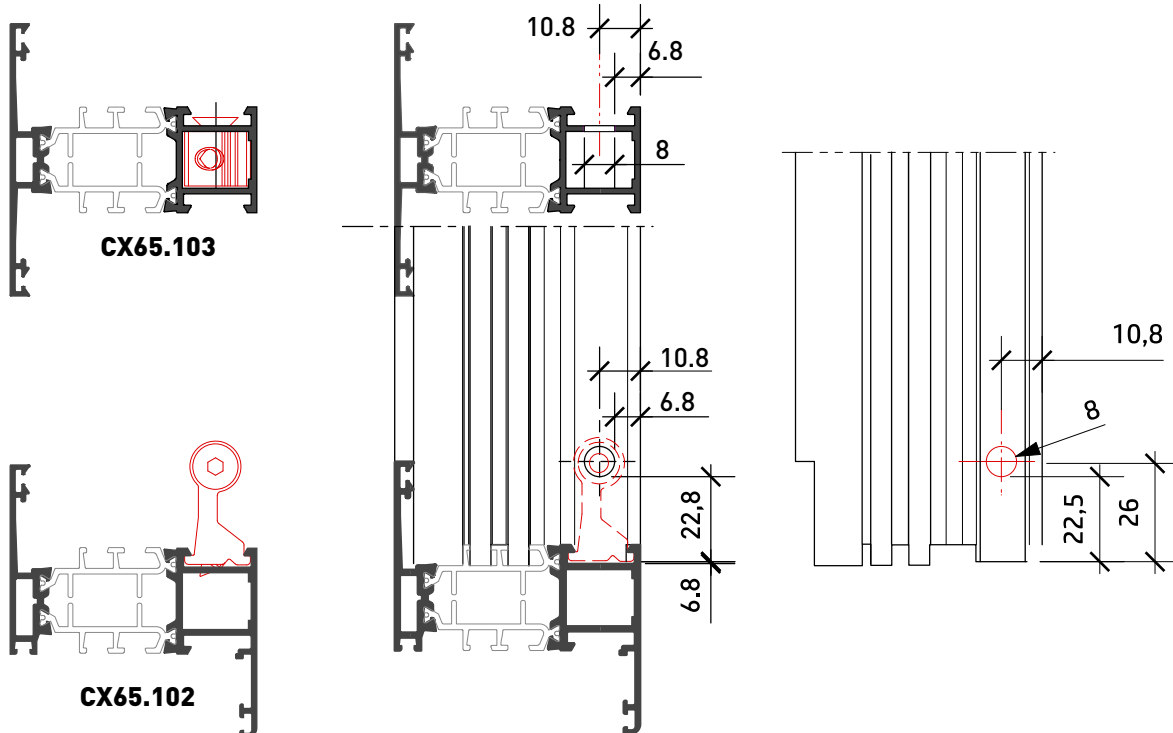
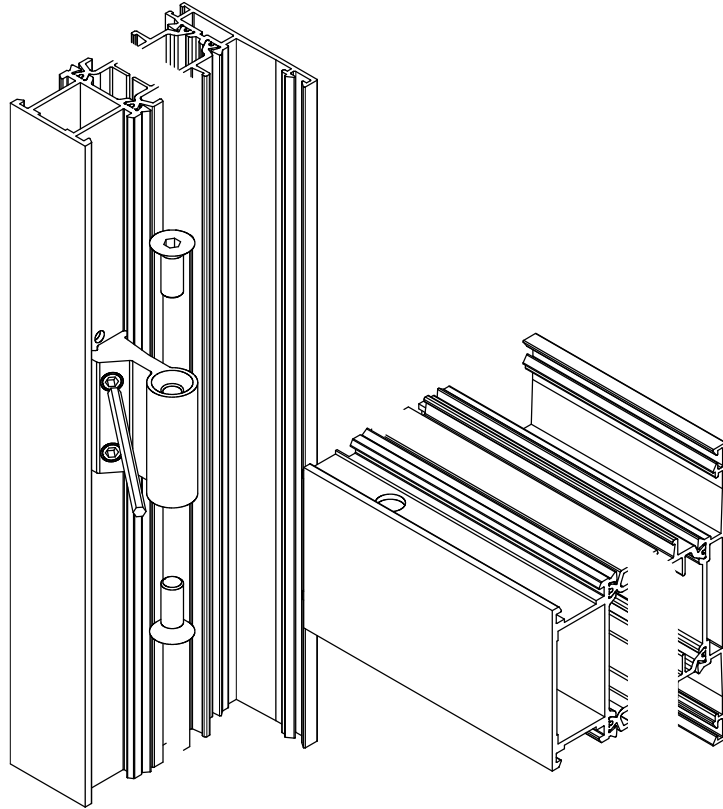
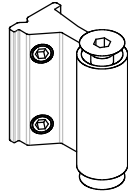

Applicazione Accessori

Application of Accessories

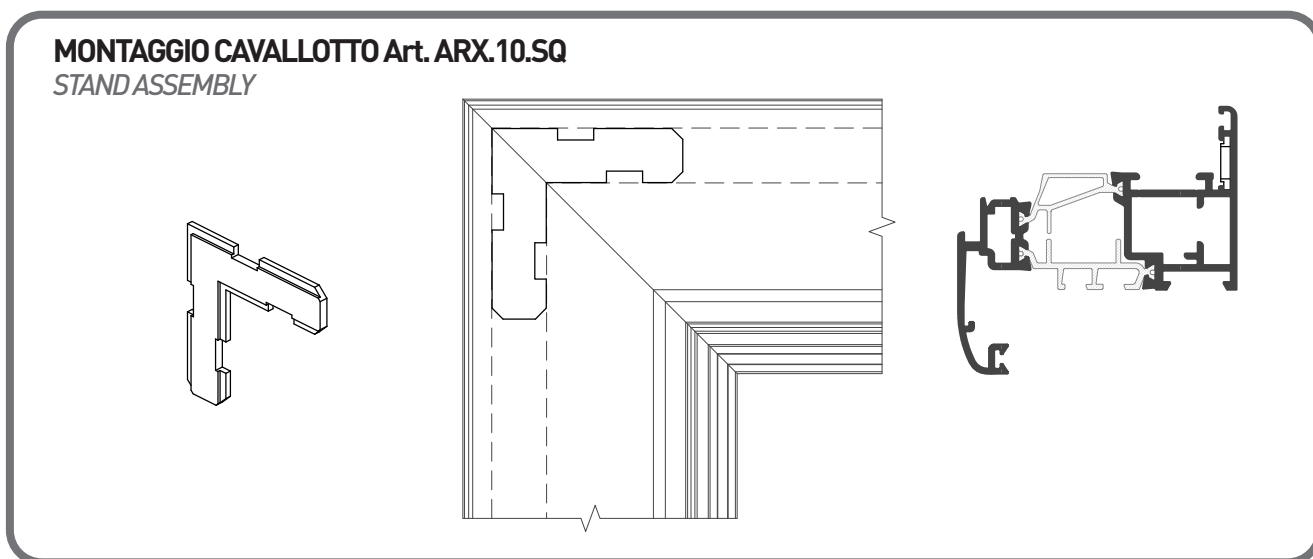
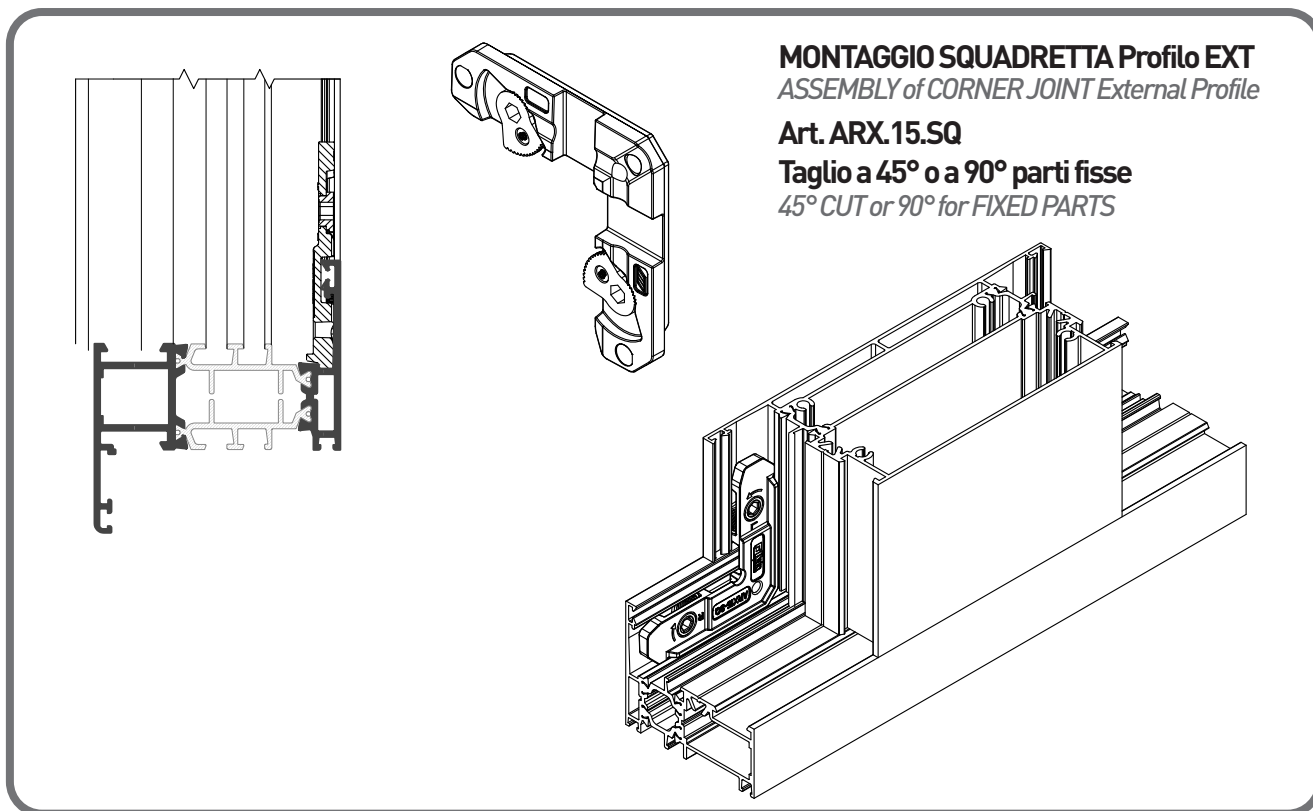

Applicazione Accessori

Application of Accessories

ARX.11.SQ

MONTAGGIO SQUADRETTA
STAND ASSEMBLY

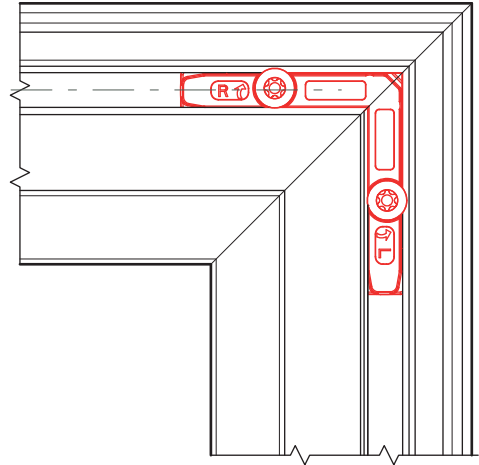
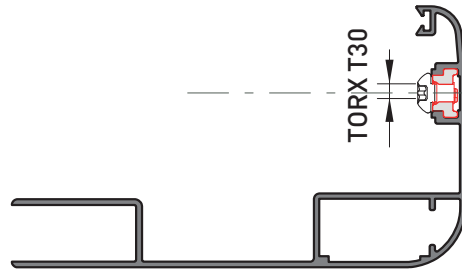
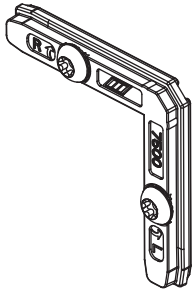

ACX 04.63

Clip per Profili XX70.503 | XX70.504

Clip for Profiles XX70.503 | XX70.504

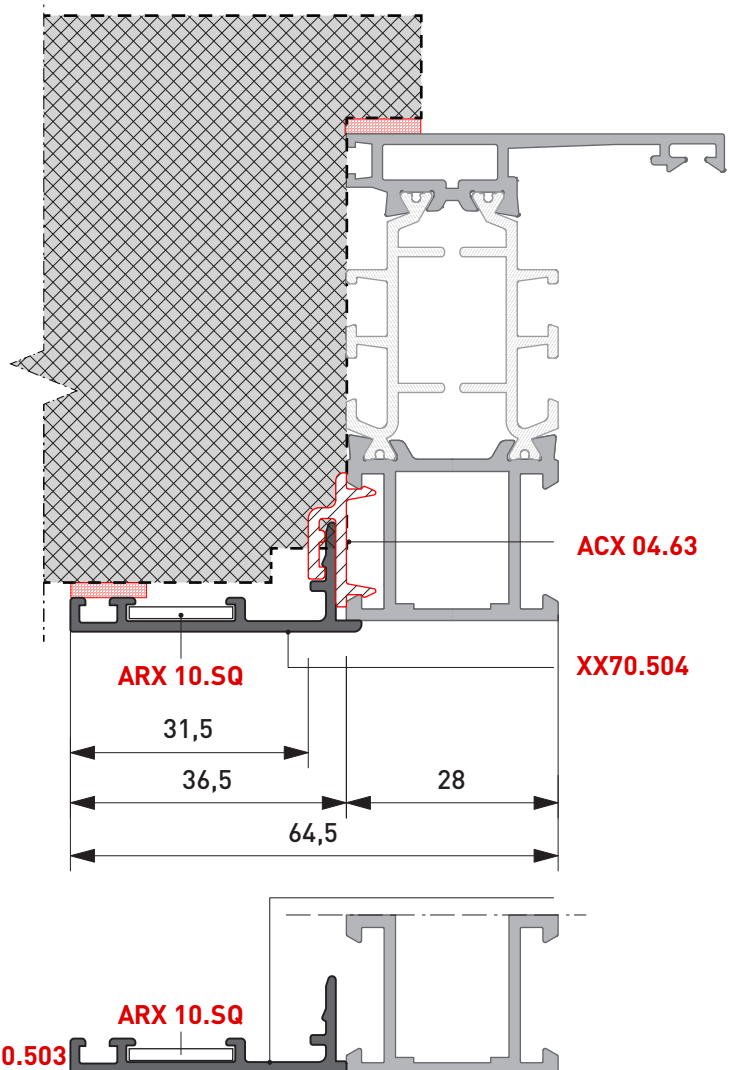
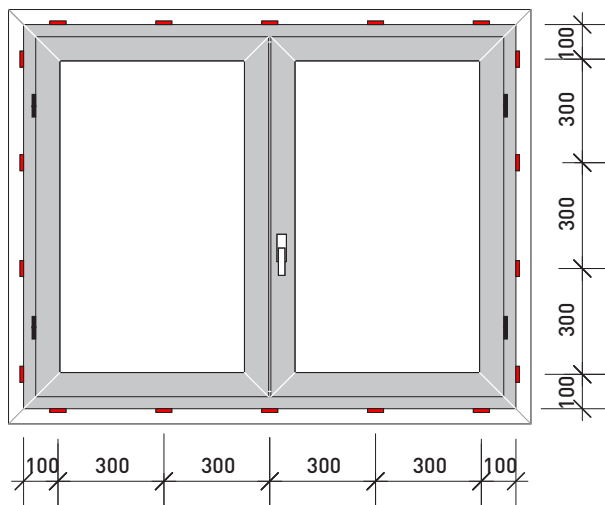
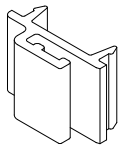

NB: Applicare le CLIPS secondo lo schema indicato quando possibile

NB: When possible, apply the CLIPS according to the present scheme

Applicazione Accessori

Application of Accessories

ACX.03.12
Terminale Asta
Bar Terminal

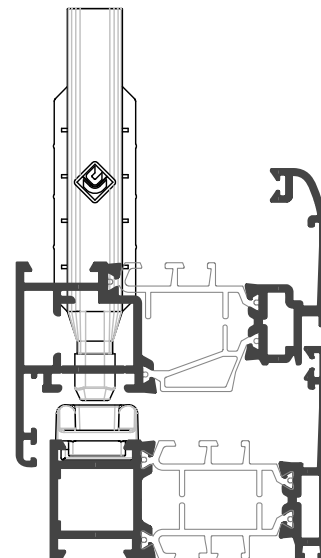
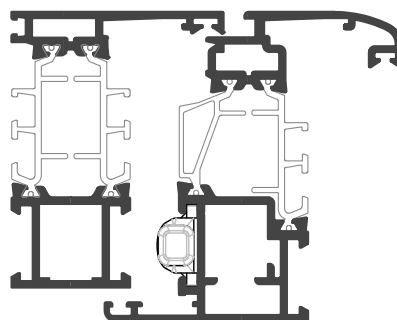
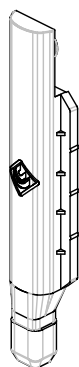

ACX.03.18
Terminale Asta in ZAMA
ZAMAC Bar Terminal

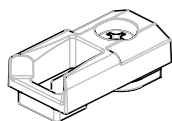
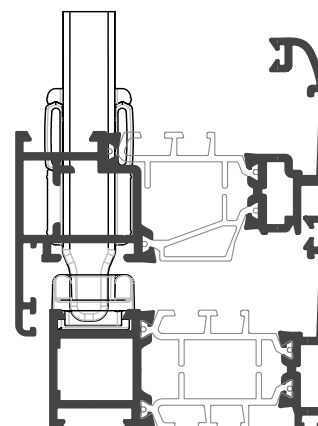
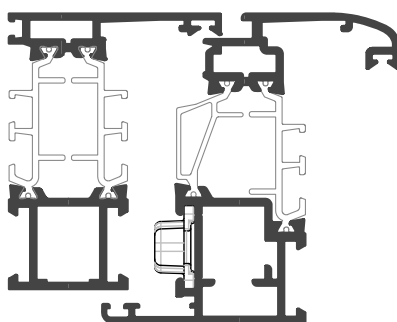
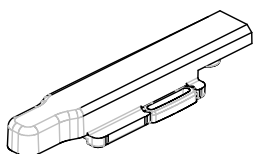

ACX.08.13
Incontro Asta singolo in ZAMA
Single Zamac Bar Rest Plate

Applicazione Accessori

Application of Accessories

SLIM

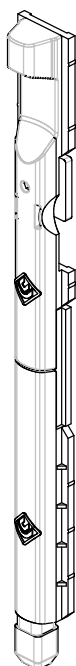

ACX.03.70
Catenaccio a comando diretto SIRIO
SIRIO direct bolt

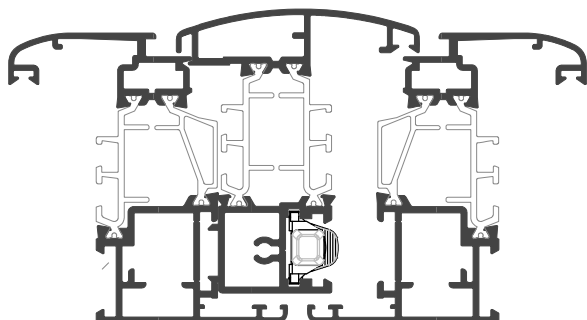

ACX.08.44
Kit Catenacci a leva per anta affiancata
Lever Bolt kit for side by side door

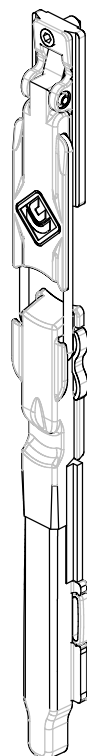
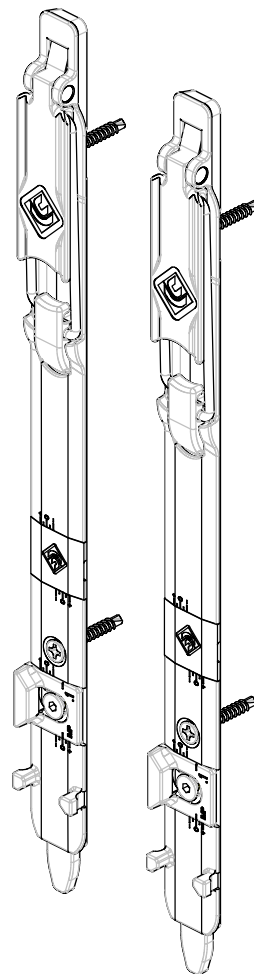
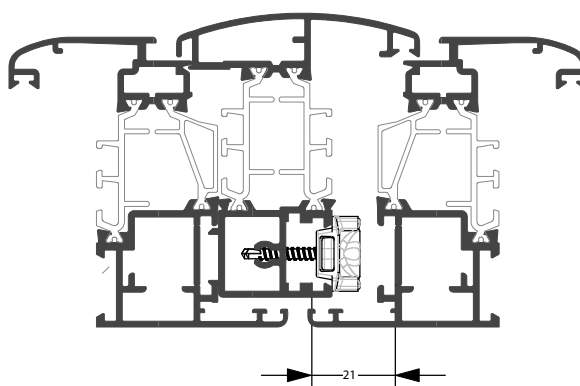

ACX.03.71
Catenaccio a Leva "Mini tex"
"Mini tex" Lever Bolt

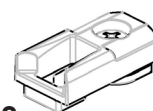
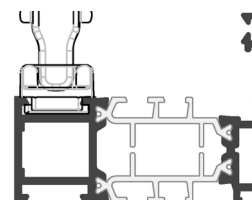
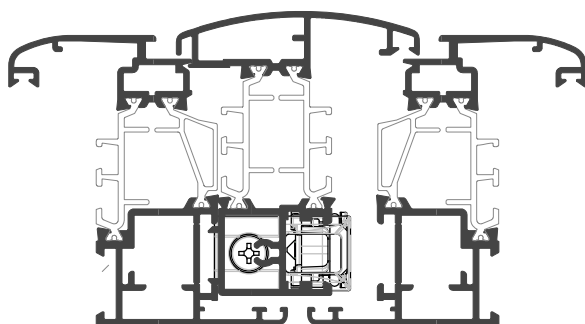

ACX.08.13
Incontro Asta Bar Rest Plate

Applicazione Accessori

Application of Accessories

ACX.03.16
KIT di chiusura Supplementare
c/Eccentrico
Supplementary closure kit
with eccentric bolt

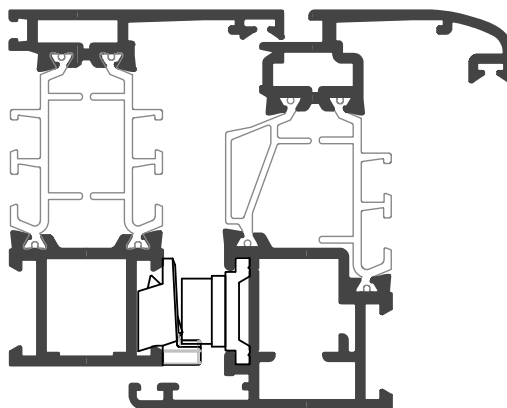
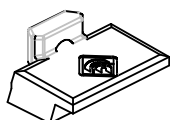

ACX.03.63
Incontro a pozzetto d = 8 mm
Drain rest plate D=8 mm

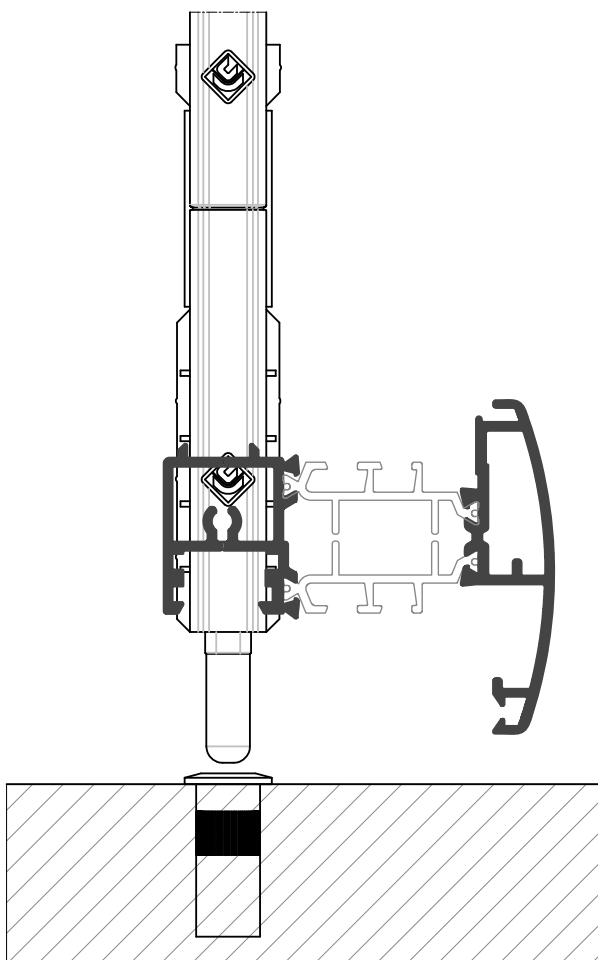
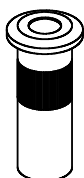

Applicazione Accessori

Application of Accessories

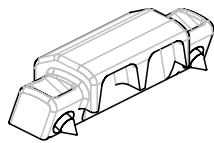

ACX.03.19
Kit sostegno anta
Door support kit

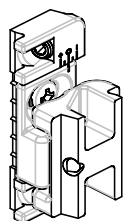
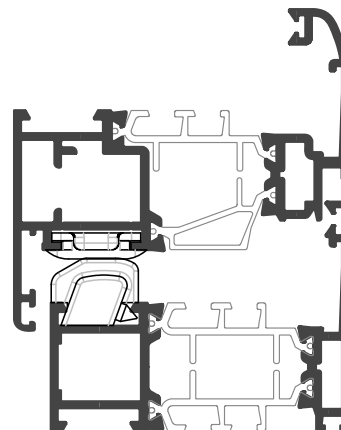
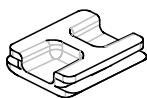

ACX.03.29
Rostro regolabile
Adjustable Bolt

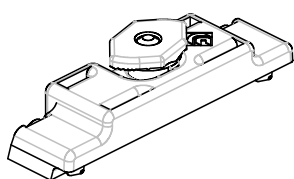
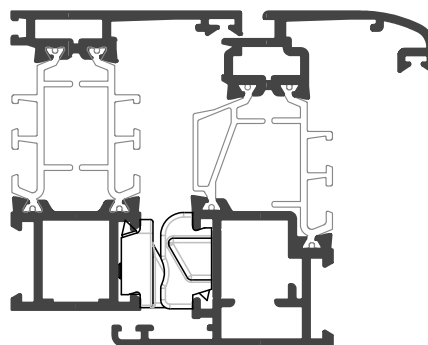

ACX.03.15
Clip ferma anta
Rabbit Clip

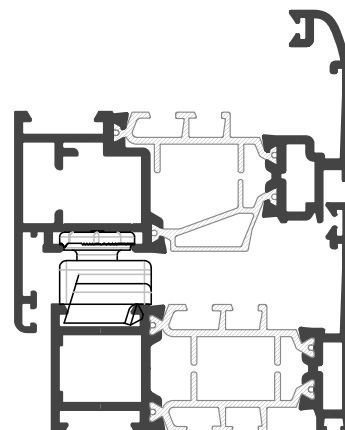

Applicazione Accessori

Application of Accessories

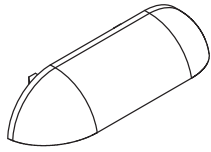

ARX.05.01
Cappetta drenaggio
Drainage plug

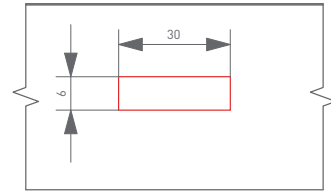
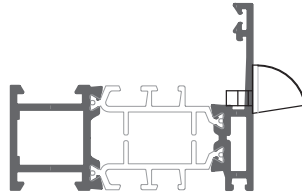

ARX.06.02
Piastrina registro Telaio
Plate adjusting screw



ARX.06.03
Registro Telaio 20 mm
Adjusting screw 20 mm

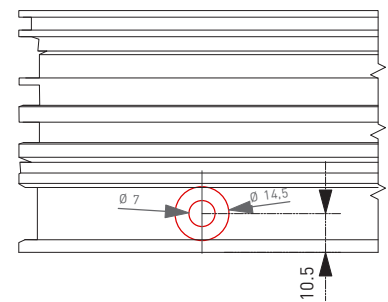
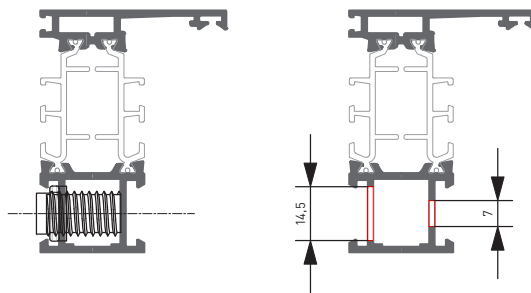

ATTENZIONE: Applicazione valida dolo per telaio ad L
ATTENTION: Application valid only for L frame

CX65.640

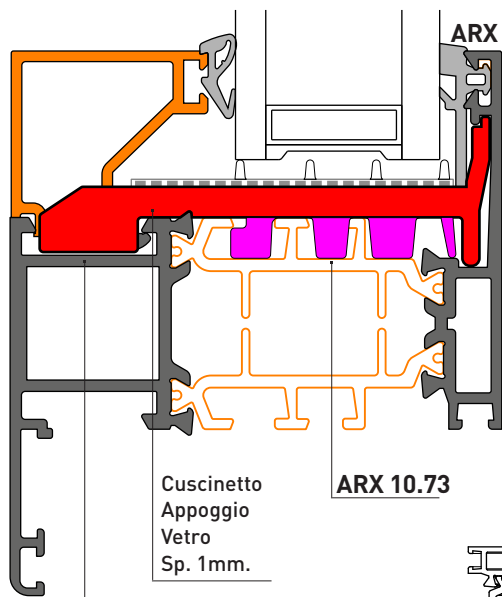

CX65.640

Cuscinetto
Appoggio
Vetro
Sp. 1mm.

ARX 10.73

ARX 10.05.1

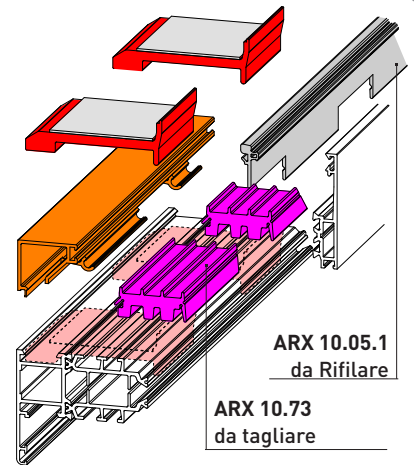
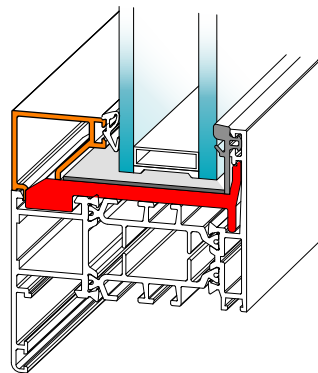

ARX 10.05.1
da Rifilare

ARX 10.73
da tagliare

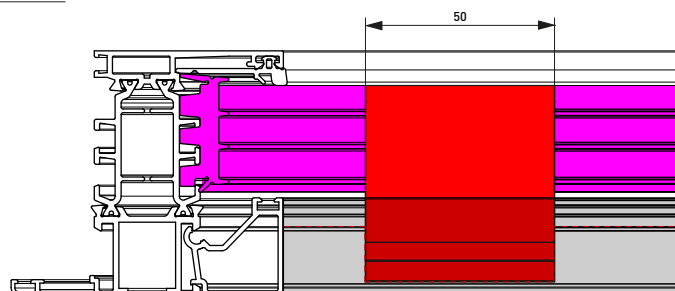

Scantonatura Fermavetro

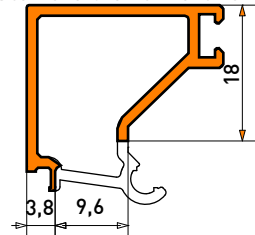

Applicazione Accessori

Application of Accessories

ACX.07.02
Angolo fermavetro
Glazing bead corner

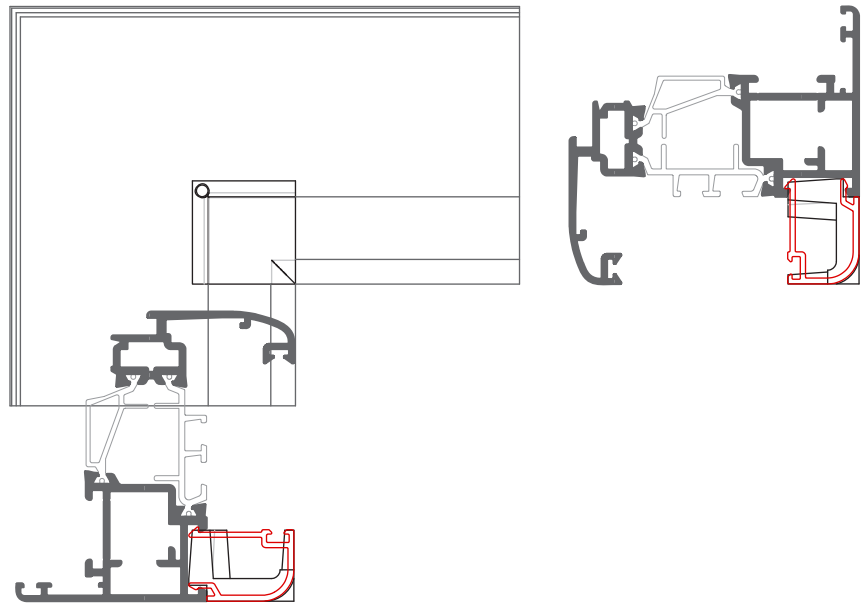
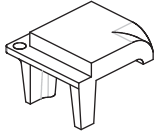

TAPPO PER PROFILIO CX65.627 (Porta a 2 ante, anta semifissa)

PLUG FOR PROFILE

(2 Sashes Door, Semi Fixed Sash)

PROFILIO: **XX75.627**

PROFILES

Art. ARX.04.30

Art. ARX.04.31

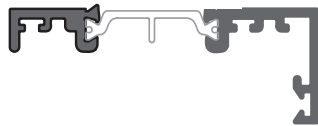

ARX.04.70 TAPPO GOCCIOLATOIO PER PROFILIO XX70.2040

PLUG FOR PROFILE

PROFILIO: **XX70.2040**

PROFILES

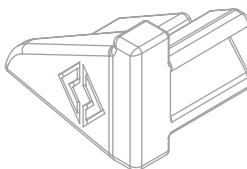

Art. ARX.04.70

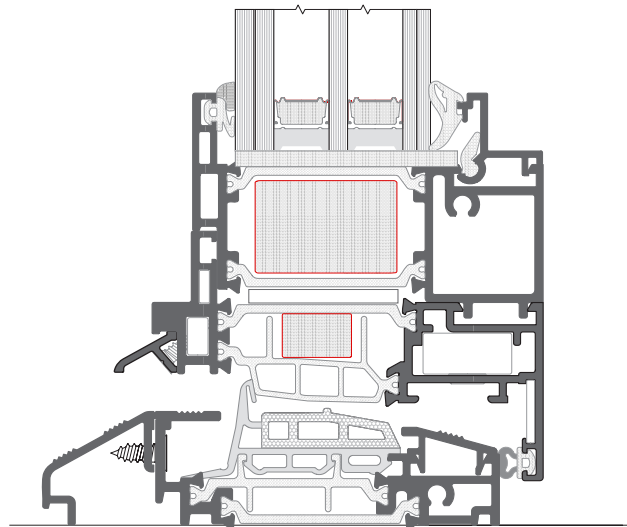

Applicazione Accessori

Application of Accessories

Coppia Tappi di Riporto camera Europea Tondo / Dritto con pre-taglio

Pair of round / straight European chamber wing plugs with pre-cutting

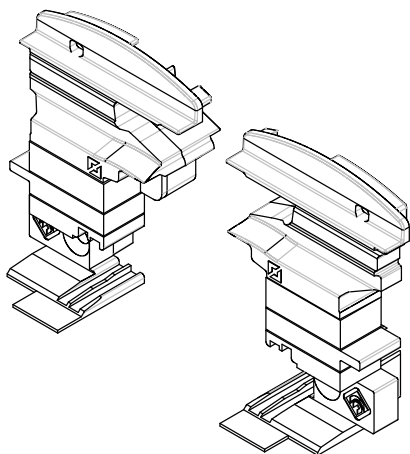

Art. ACX.04.51

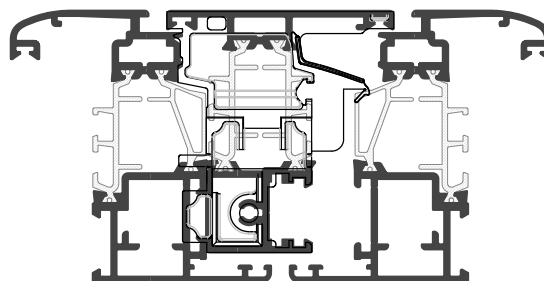
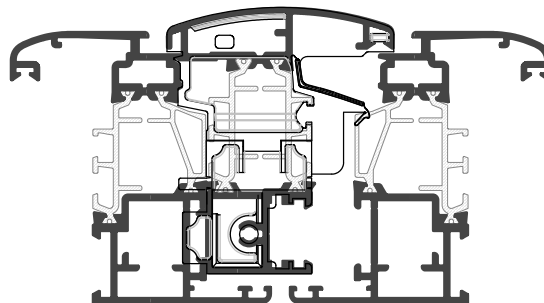

Coppia Tappi di Riporto Ferramenta a Nastro Tondo / Dritto con pre-taglio

Pair of round / straight tape hardware wing plugs with pre-cutting

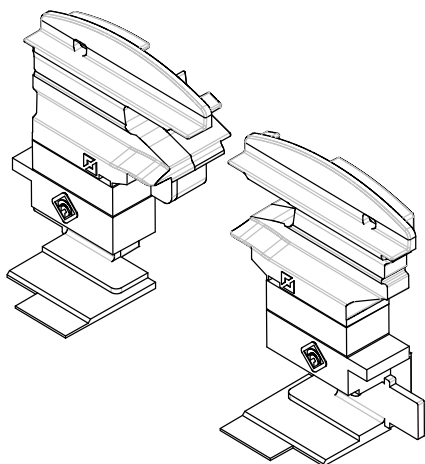

Art. ACX.04.52

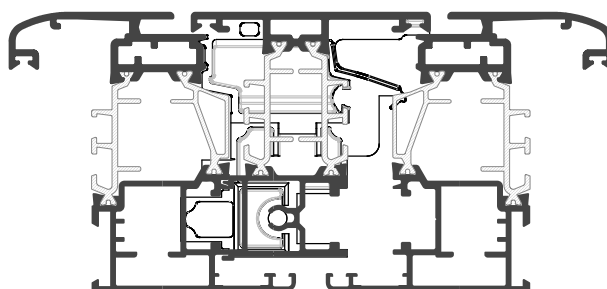
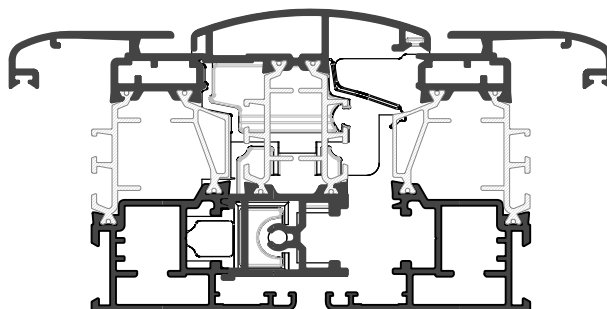

Applicazione Accessori

Application of Accessories

Coppia Tappi di Riporto Doppia Battuta Tondo / Dritto con pre-taglio

Pair of round / straight double door stop wing plugs with pre-cutting

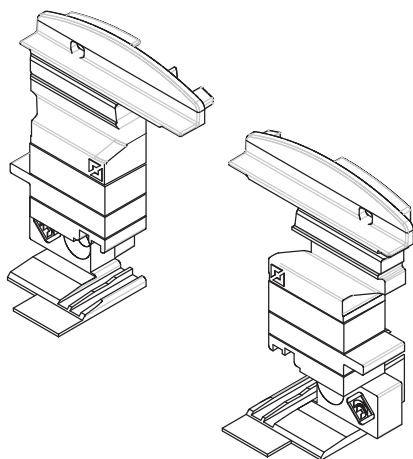

Art. ACX.04.53

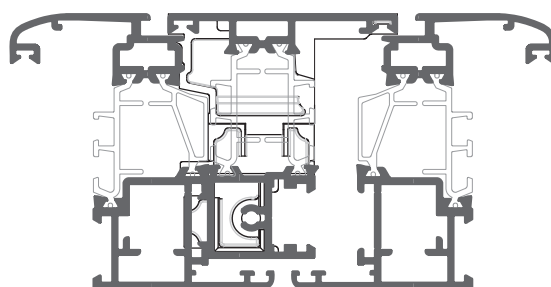
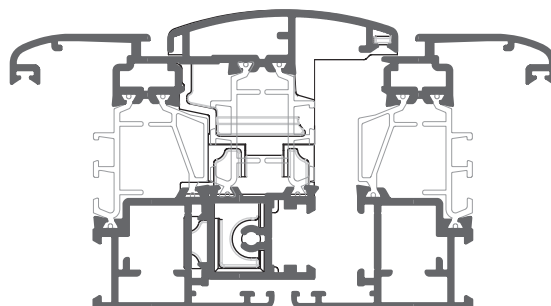

Kit Tappi di Riporto Doppia Battuta per XX70.643

Kit double sash door plugs for XX70.643

Art. ARX.04.60

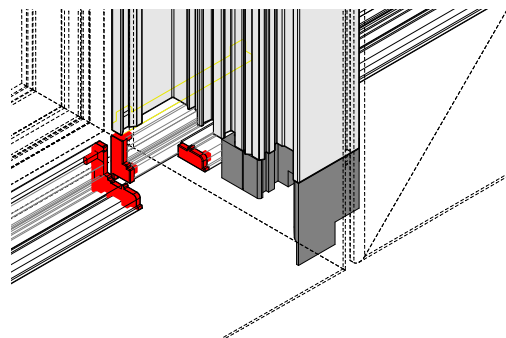
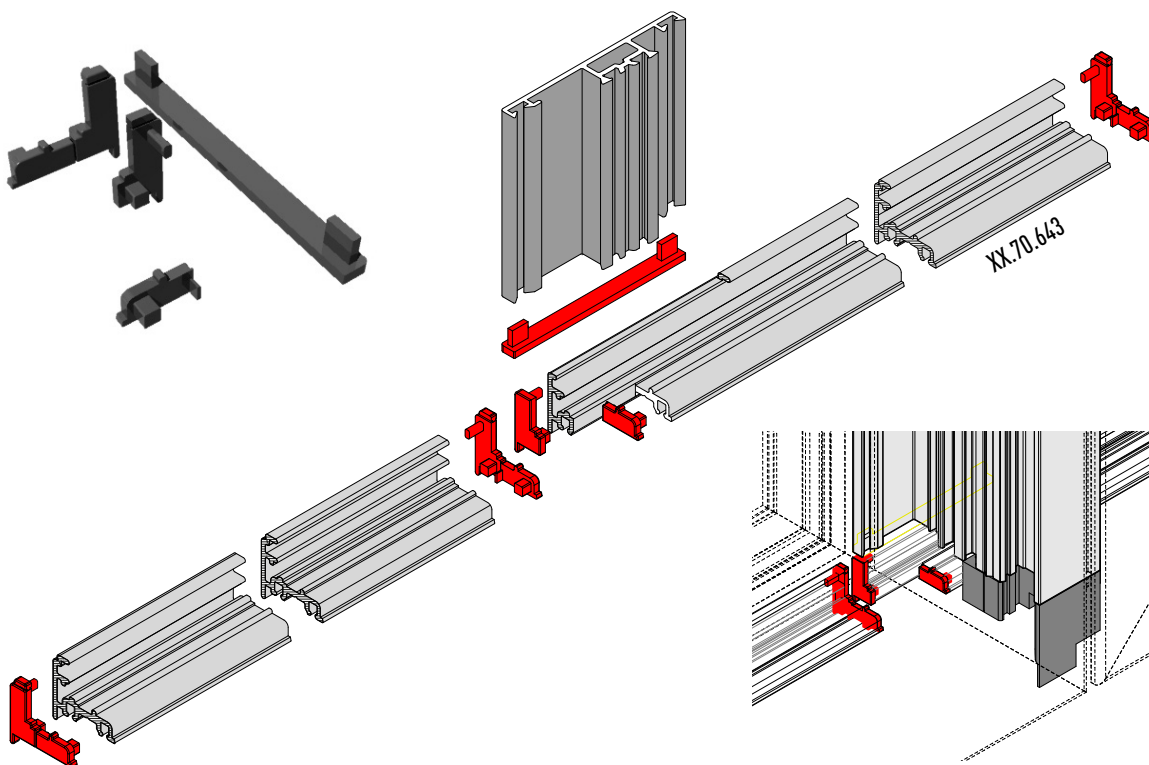

Applicazione Accessori

Application of Accessories

Art. XX70.643

Profilo Porta Spazzolino per Anta Doppia Battuta. Apertura Esterna
Brush Holder Profile for Double Stop Sash. External Opening

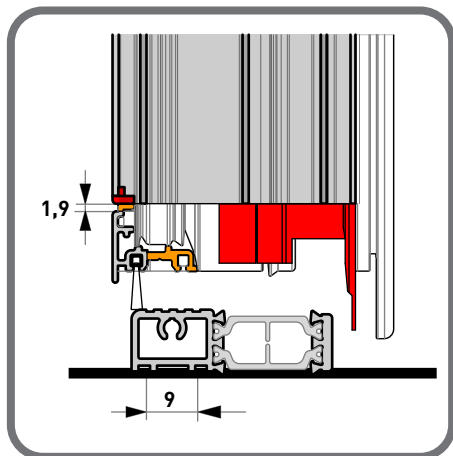
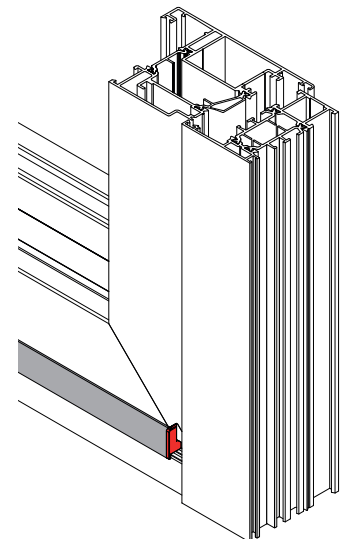
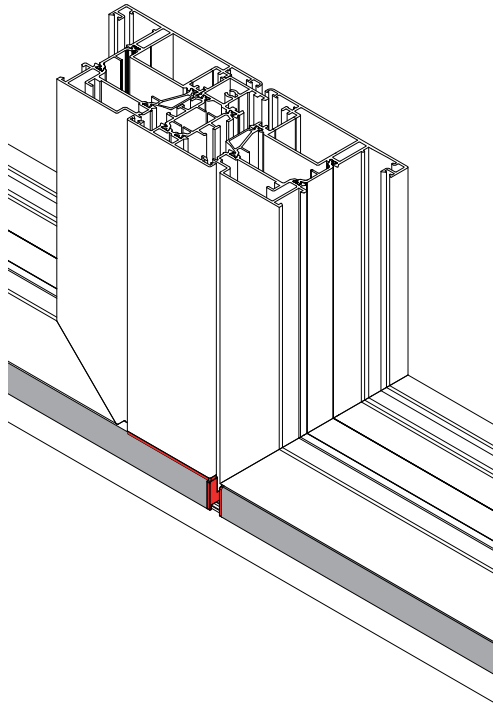
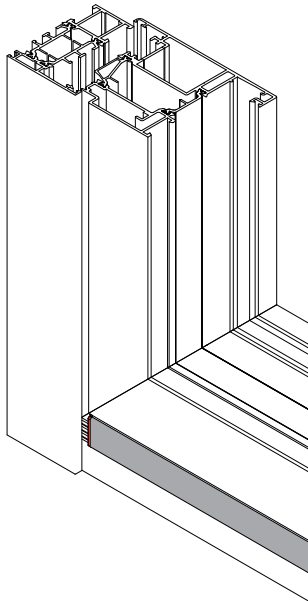

Spazzolino | ARX10.83
Brush

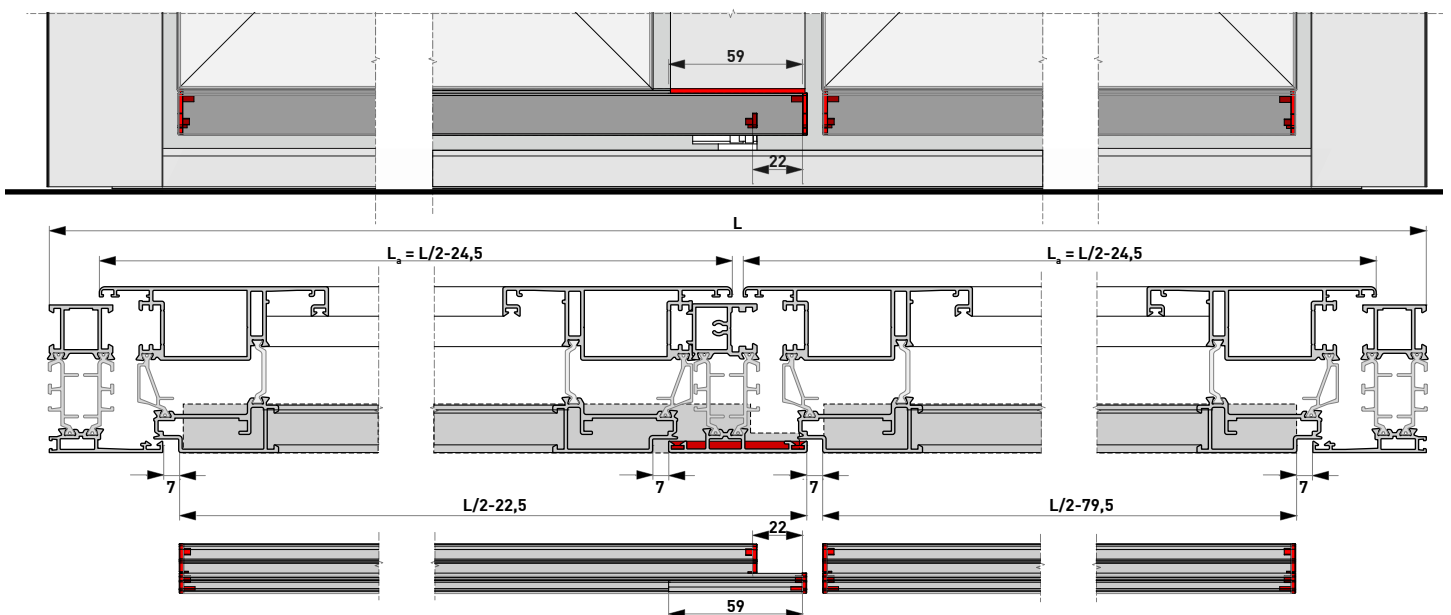



SOLUZIONE BILICO PIVOT VERSION

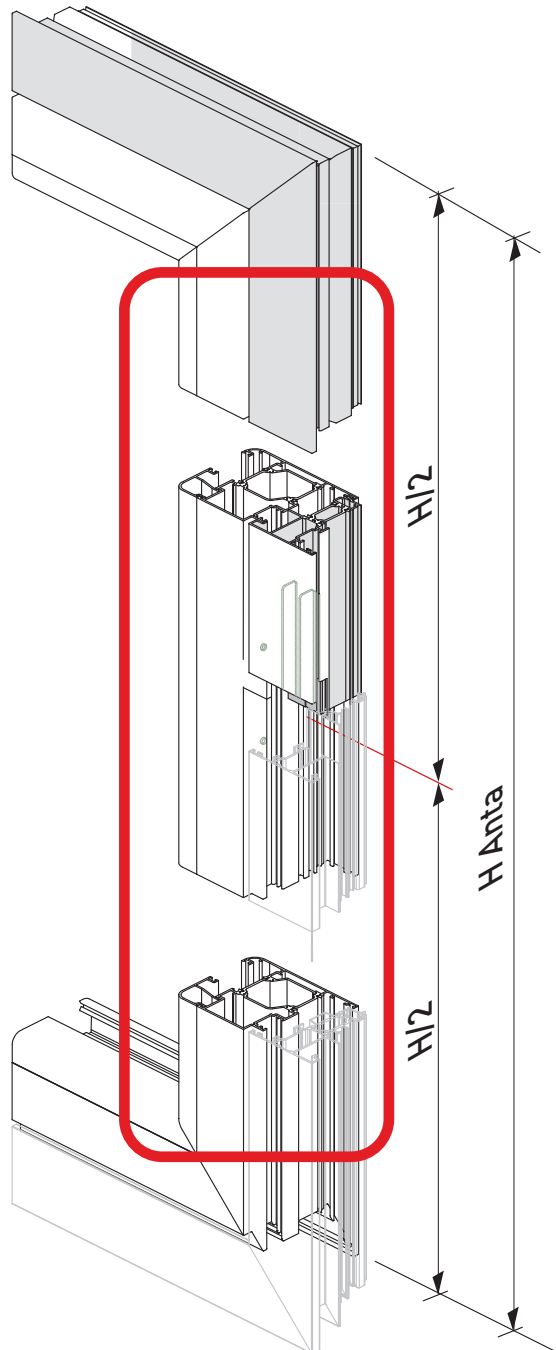
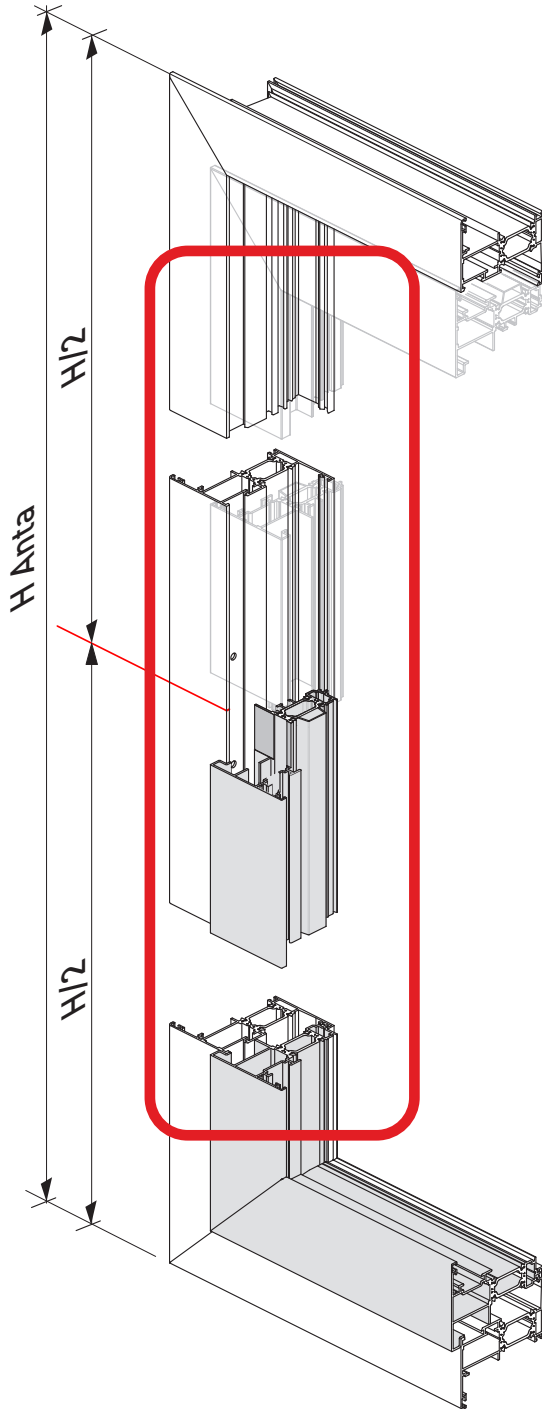
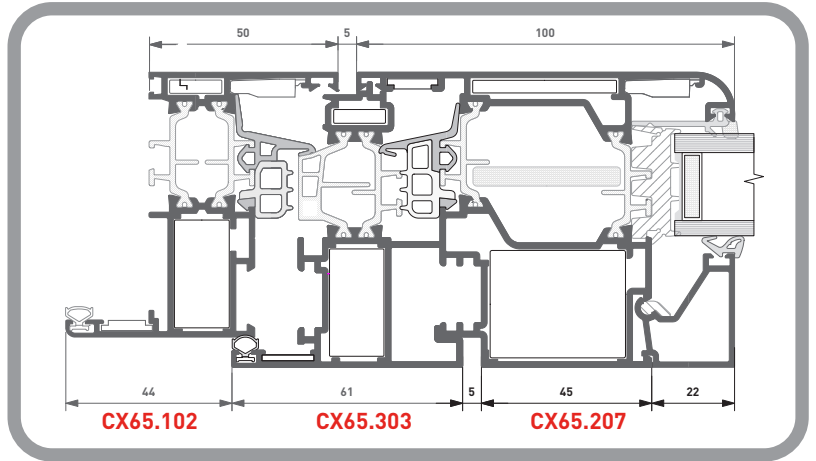



SOLUZIONE BILICO PIVOT VERSION

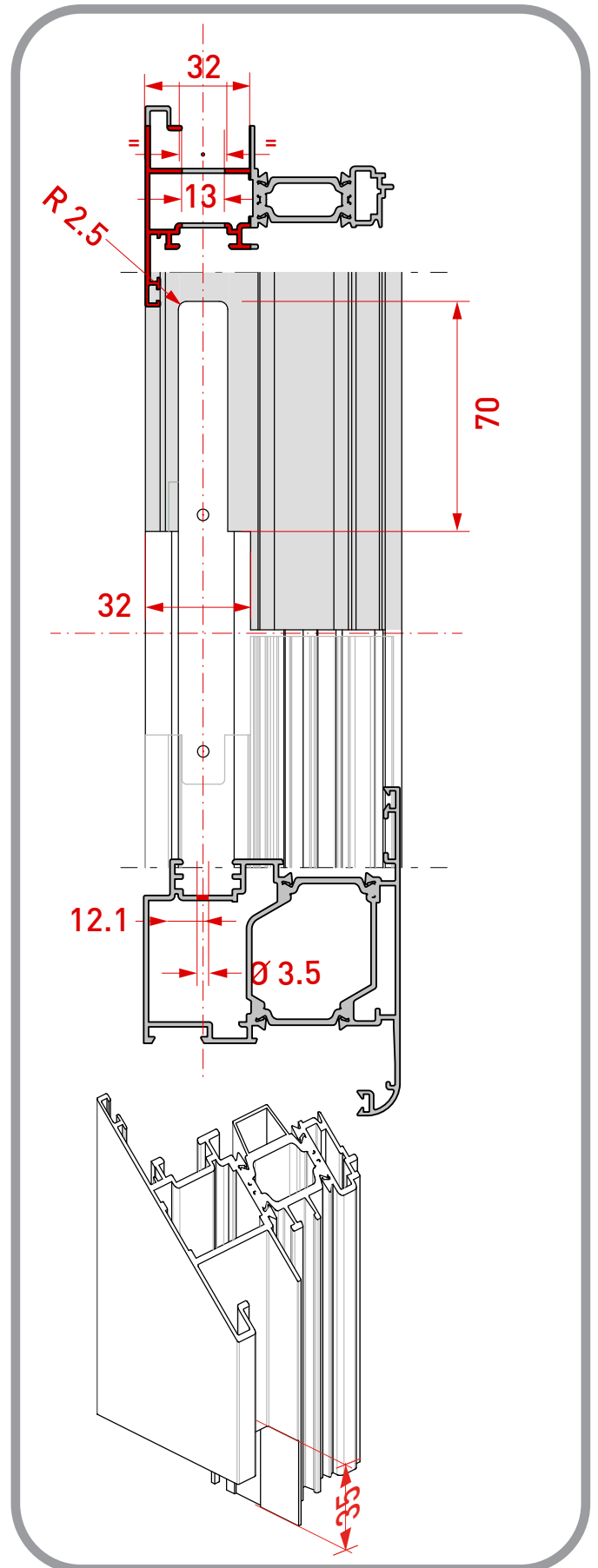
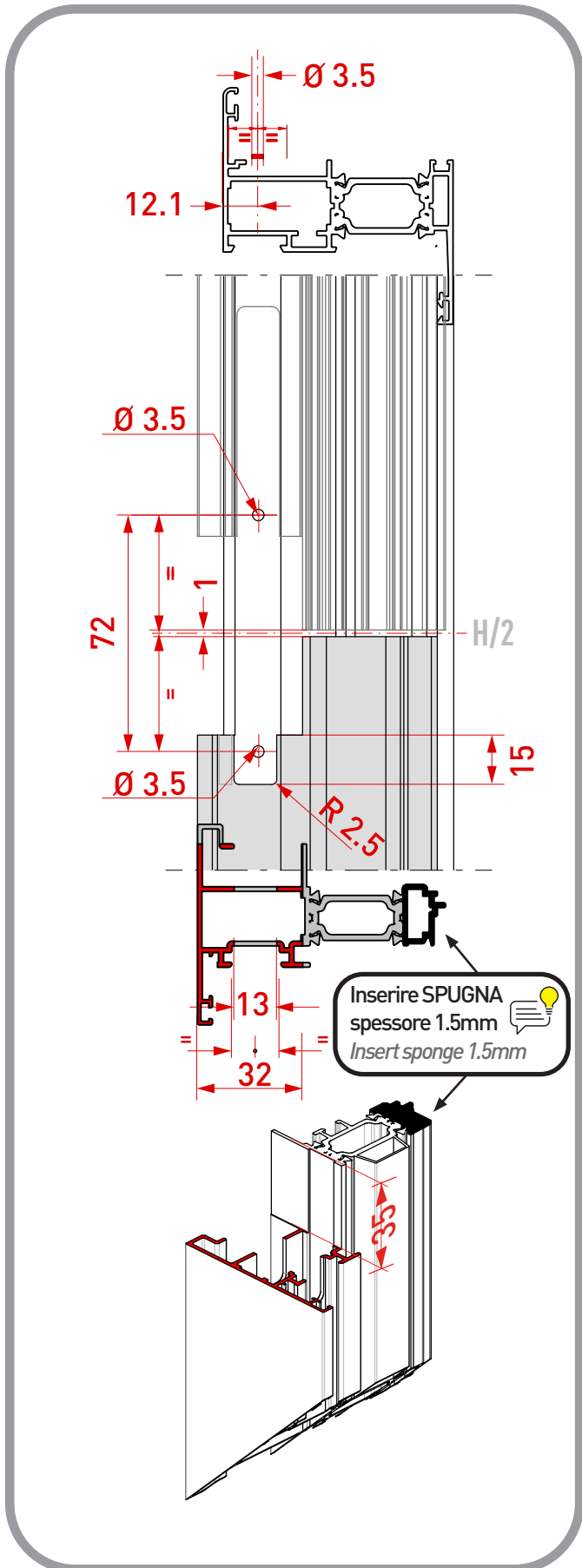

Applicazione Accessori

Application of Accessories
SOLUZIONE BILICO PIVOT VERSION

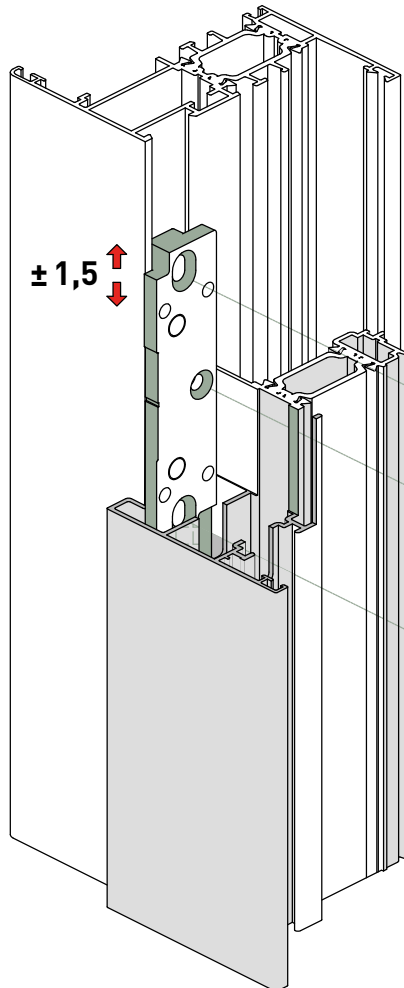

± 1,5

TSP 4,2 x 25

Spessore 2

TSP 3,9 x 25

- Soluzione non utilizzabile con profili COMPLANARI
- Solution not applicable with coplanar profiles

- Fissare DOPO la regolazione dell'Anta in Altezza
- Secure AFTER adjusting the Sash height

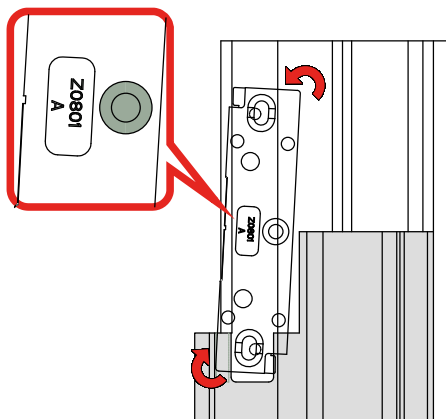
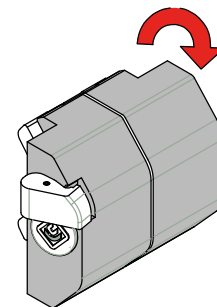

Regolazione in altezza

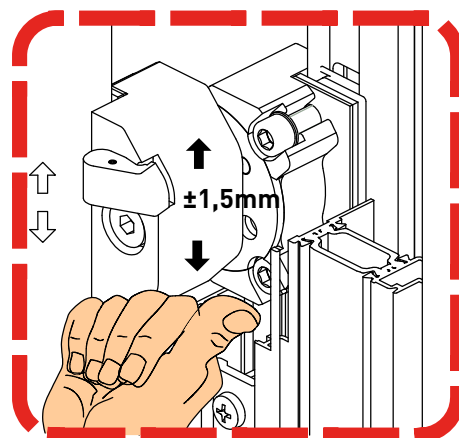

Applicazione Accessori

Application of Accessories
SOLUZIONE BILICO PIVOT VERSION

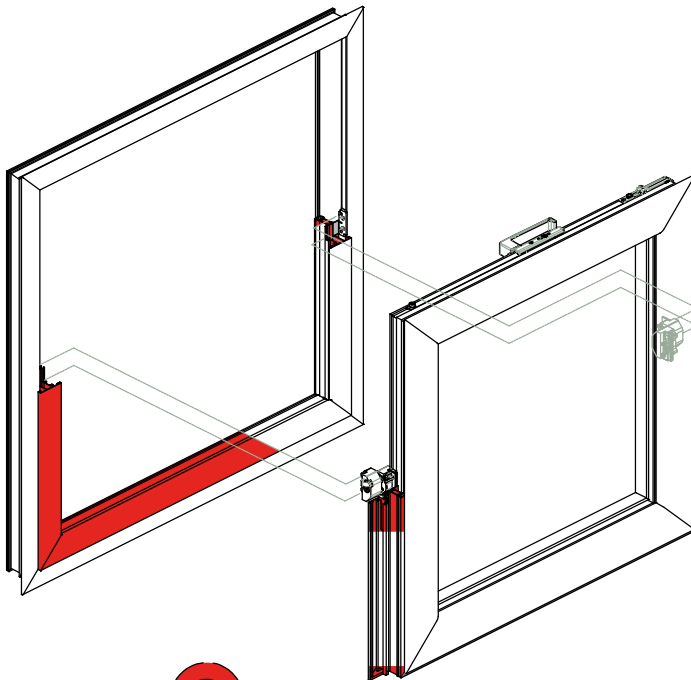



- Soluzione non utilizzabile con profili COMPLANARI
- Solution not applicable with coplanar profiles

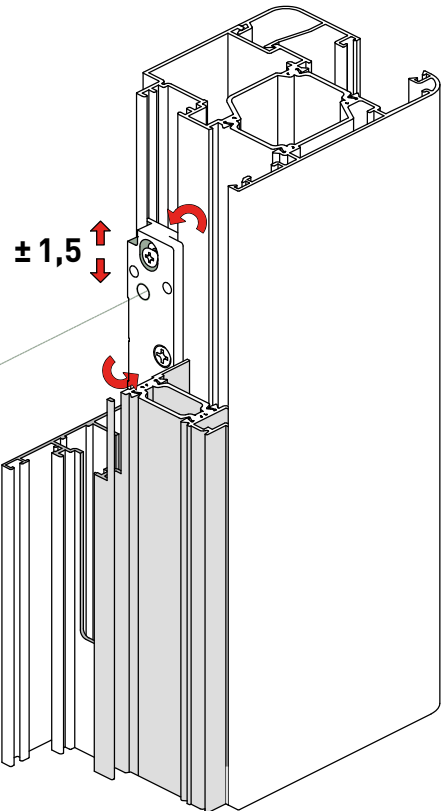
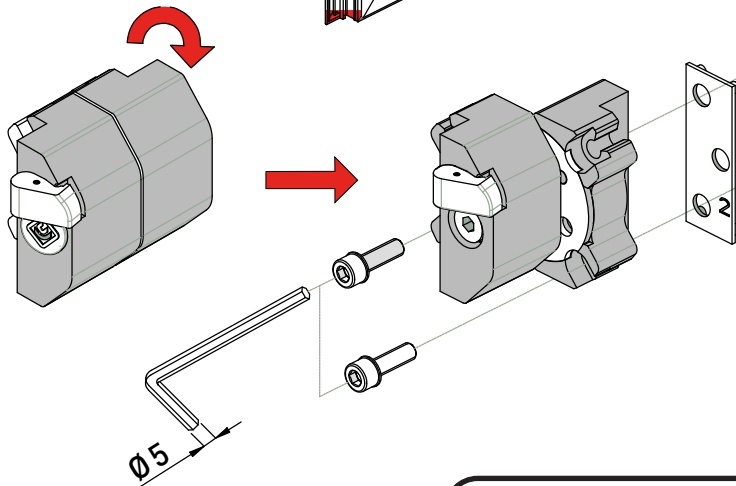



- Fissare la Cerniera con BLOCCO sul lato SINISTRO
- Attach the Hinge with LOCK on the LEFT side.

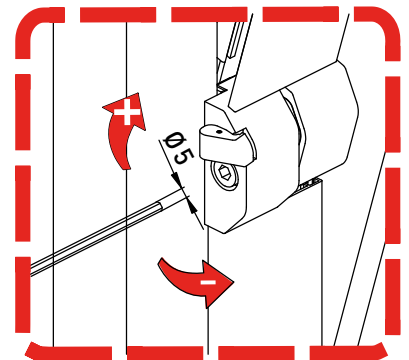
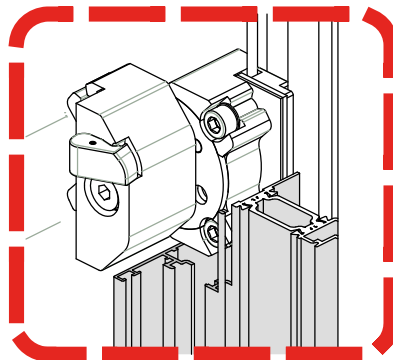
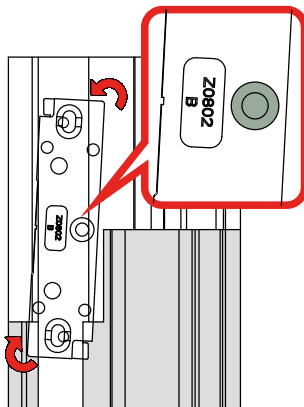

Applicazione Accessori

Application of Accessories
SOLUZIONE BILICO PIVOT VERSION

Horizontal

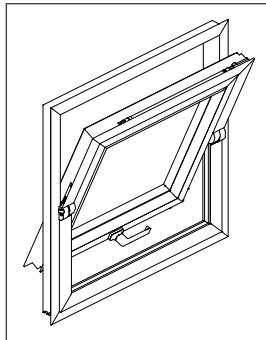

kg 120

Vertical

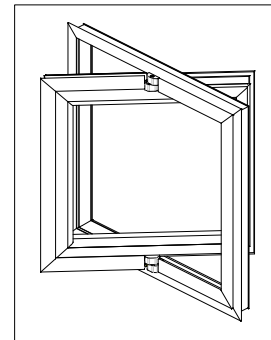

kg 80

Diagramma di carico - Application range



Diagramma di carico - Application range



H 2000	A	ARX 03.75	1 cp	A	ARX 03.75	1 cp
	B	ACX 03.77	1 pz	B	ACX 03.77	1 pz
	C	ACX 03.78	1 pz	C	ACX 03.78	1 pz
	D	ACX 03.79	1 pz	D	ACX 03.79	1 pz
	G	ARX 03.80 + ACX 03.81	2 pz	G	ARX 03.80 + ACX 03.81	4 pz
H 1800	A	ARX 03.75	1 cp	A	ARX 03.75	1 cp
	B	ACX 03.77	1 pz	B	ACX 03.77	1 pz
	C	ACX 03.78	1 pz	C	ACX 03.78	1 pz
	D	ACX 03.79	1 pz	D	ACX 03.79	1 pz
H 550	A	ARX 03.75	1 cp	A	ARX 03.75	1 cp
	B	ACX 03.77	1 pz	B	ACX 03.77	1 pz
	C	ACX 03.78	1 pz	C	ACX 03.78	1 pz
						L 2500

H 1800	A	ARX 03.76	1 cp	A	ARX 03.76	1 cp
	B	ACX 03.77	1 pz	B	ACX 03.77	1 pz
	C	ACX 03.78	1 pz	C	ACX 03.78	1 pz
	D	ACX 03.79	1 pz	D	ACX 03.79	1 pz
	G	ARX 03.80 + ACX 03.81	2 pz	G	ARX 03.80 + ACX 03.81	4 pz
H 1000	A	ARX 03.76	1 cp	A	ARX 03.76	1 cp
	B	ACX 03.77	1 pz	B	ACX 03.77	1 pz
	C	ACX 03.78	1 pz	C	ACX 03.78	1 pz
H 550	A	ARX 03.76	1 cp	A	ARX 03.76	1 cp
	B	ACX 03.77	1 pz	B	ACX 03.77	1 pz
						L 1400

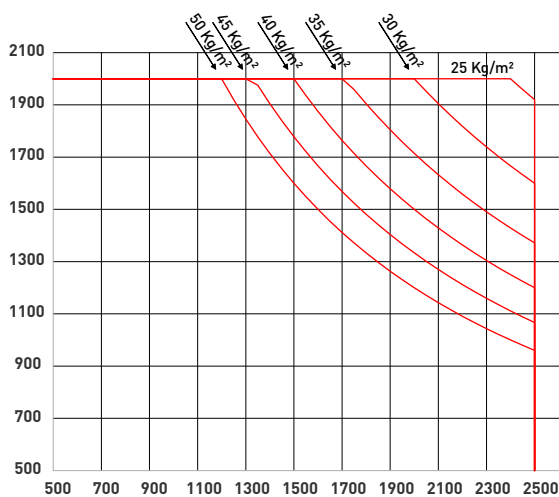
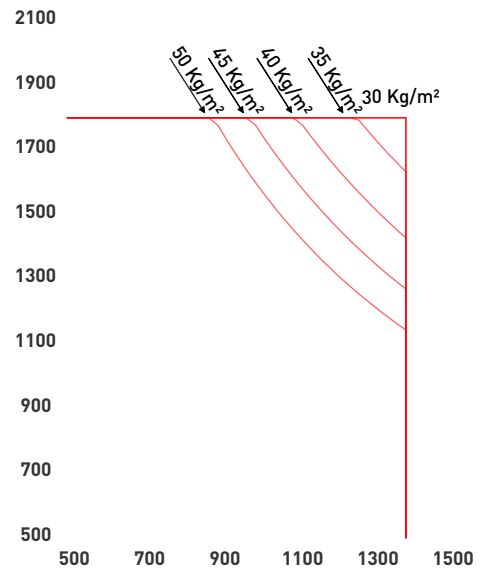
Applicazione Accessori

Application of Accessories

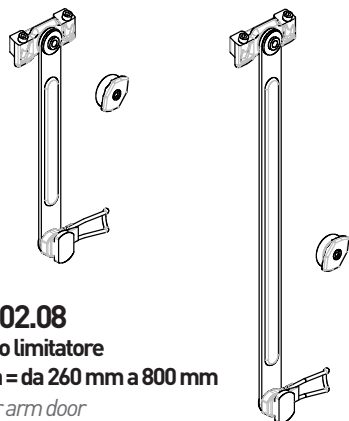

ACX.02.08
Braccio limitatore
H Anta = da 260 mm a 800 mm
Limiter arm door
H Sash = from 260mm to 800mm

ACX.02.07
Braccio limitatore
H Anta = da 600 mm a 1600 mm
Limiter arm door
H Sash = from 600mm to 1600mm

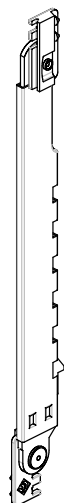

ACX.02.09
Braccio Telescopico
a Scatto
One click telescopic arm

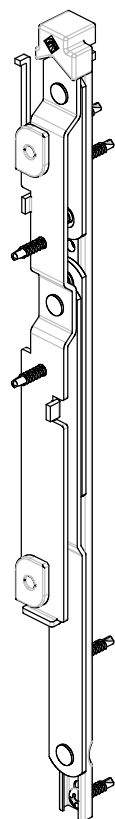
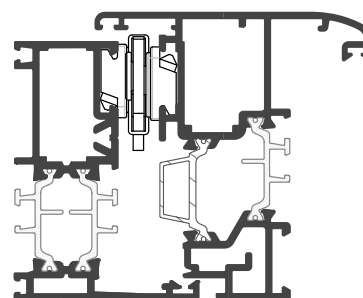
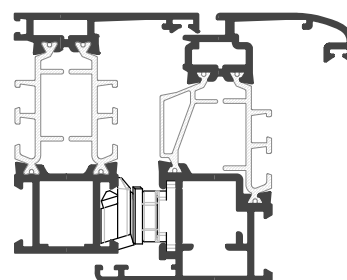

ACX.02.10
Cerniera a compasso
Compass Hinge

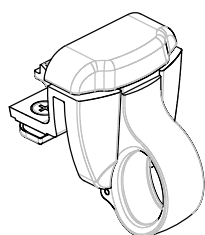
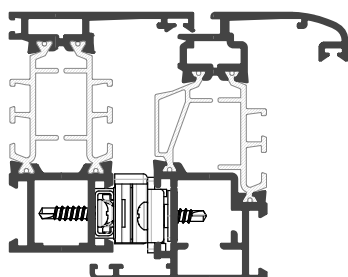

ACX.03.01
Cricchetto ad aggancio
con piastrene
Coupling ratchet
with plates

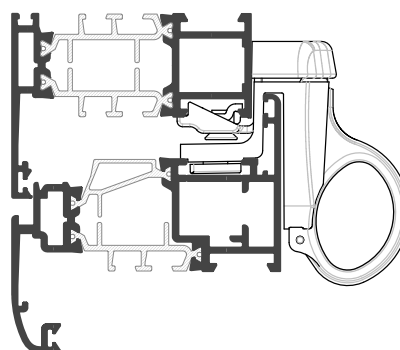

Applicazione Accessori

Application of Accessories

ARX.03.02
Maniglia a Tavellino
Tavellino Handle

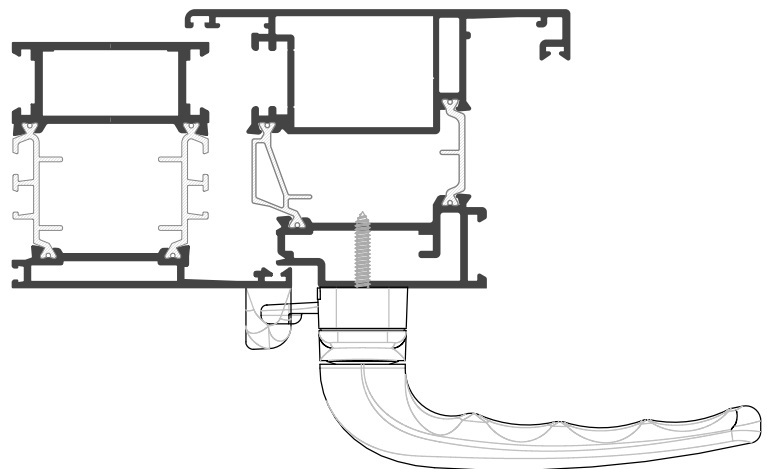
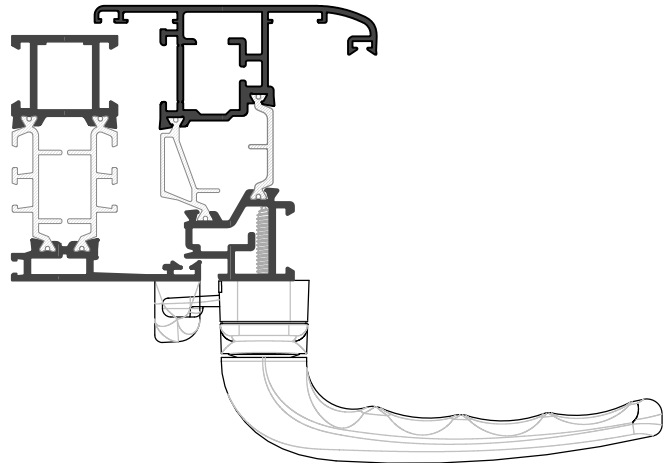
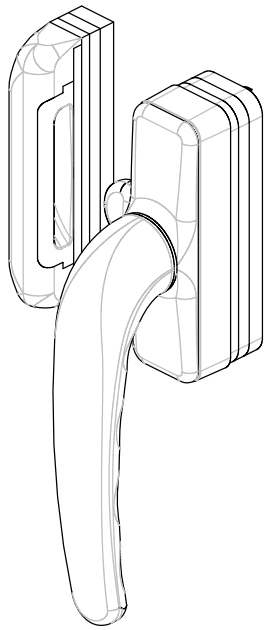

Applicazione Accessori

Application of Accessories



ACX.03.73
"COMFORT MINI"
Martellina ridotta
Sporgenza quadro 70 mm
*Reduced Martellina handle
Square rosette projection
mm.70*

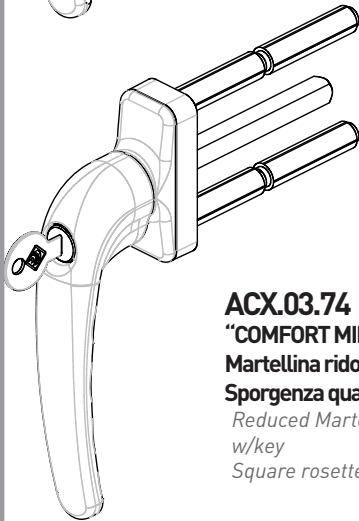
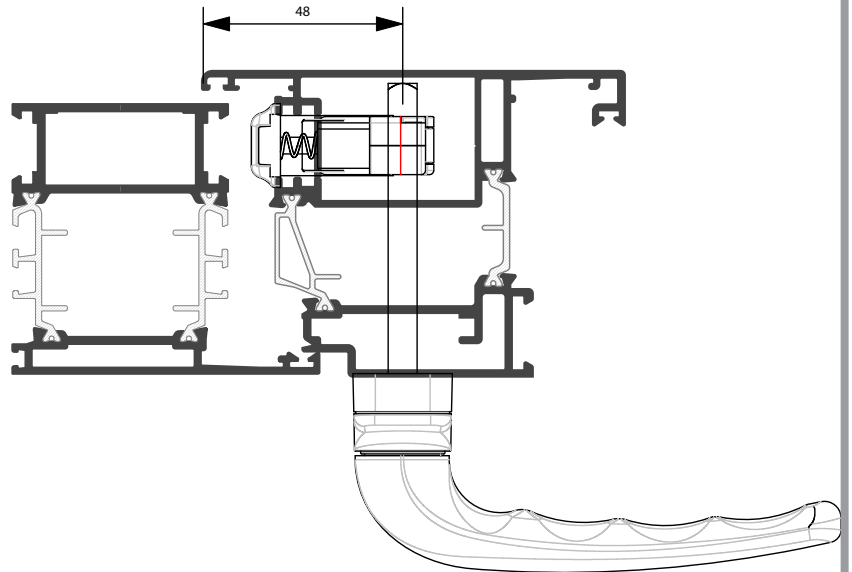

ACX.03.74
"COMFORT MINI"
Martellina ridotta con cilindro
Sporgenza quadro 70 mm
*Reduced Martellina handle
w/key
Square rosette projection 70 mm*

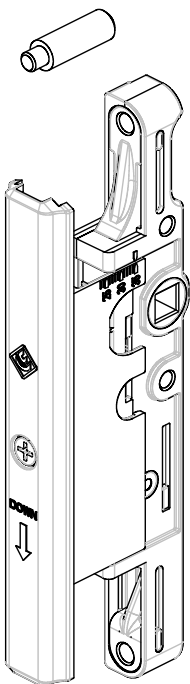
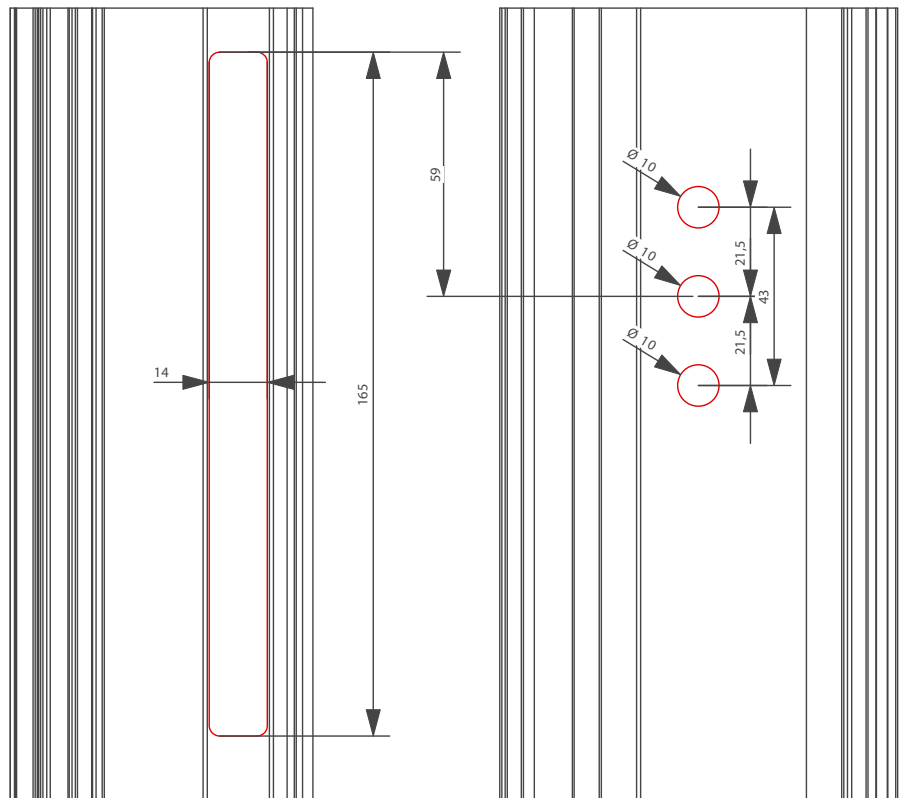

ARX.03.67
Perno di trascinamento
L = 27 mm
Winding pivot n L = 27 mm

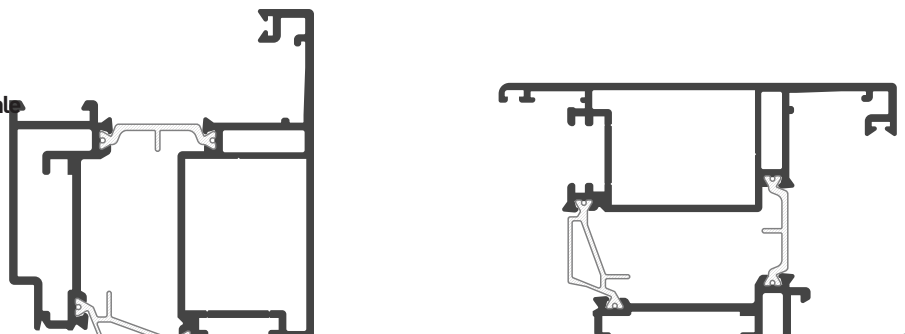

ACX.03.72
Movimentazione Bidirezionale
Interasse 23 - 35 mm
*Bi-directional movement
Center Distance 23 - 35 mm*

Applicazione Accessori

Application of Accessories

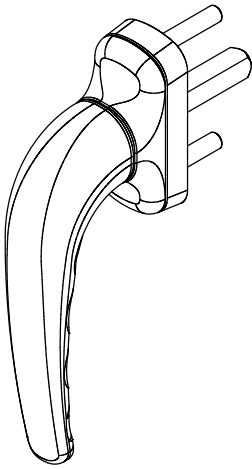

ARX.03.04
Martellina
Sporgenza quadro 24 mm
Martellina Handle
Square Rosette projection 24 mm

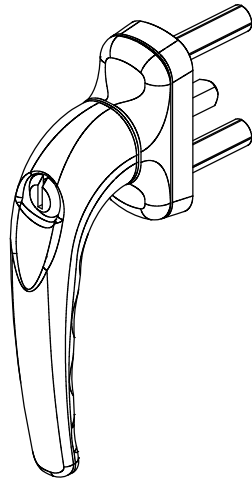

ARX.03.05
Martellina con chiave
Sporgenza quadro 24 mm
Martellina Handle with key
Square rosette projection 24 mm

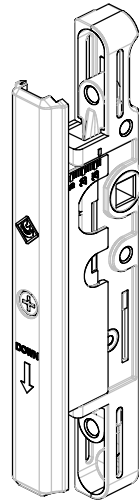

ACX.03.66
Perno L = 11 mm
Pivot L = 11 mm

ARX.03.09
Movimentazione bidirezionale
regolabile 15 - 27 mm
Adjustable bidirectional
movement 15 - 27 mm

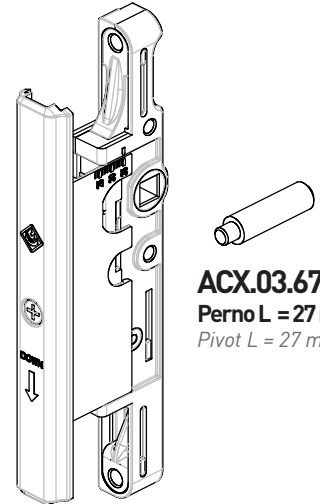

ACX.03.67
Perno L = 27 mm
Pivot L = 27 mm

ACX.03.72
Movimentazione bidirezionale
regolabile 23 - 35 mm
Adjustable bidirectional
movement 23 - 35 mm

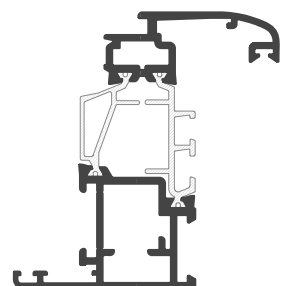
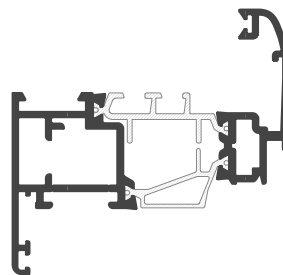
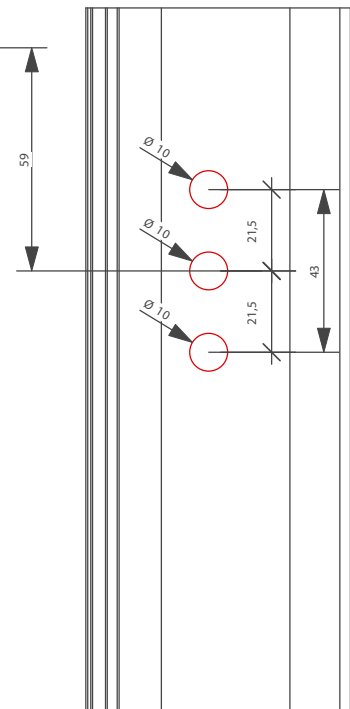
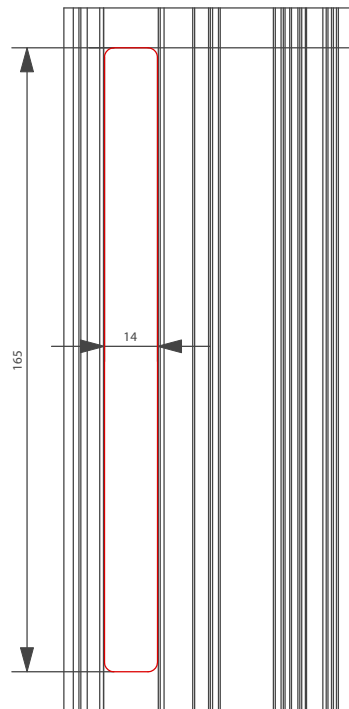
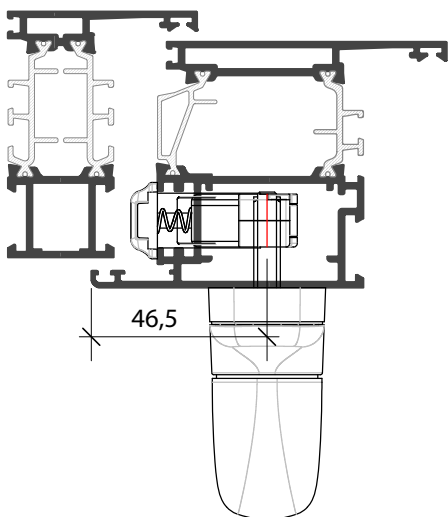
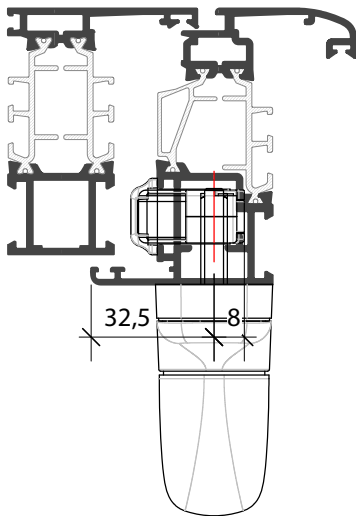

Applicazione Accessori

Application of Accessories

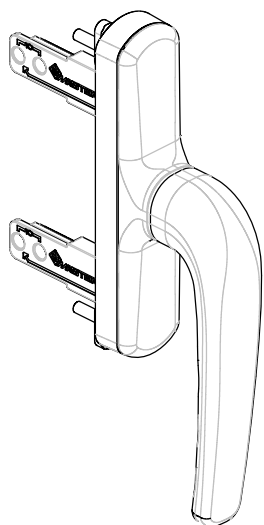

ARX.03.50
Cremonese Apertura
esterna - int. 37/65mm
Cremonese bolt external
opening - int. 37/65mm

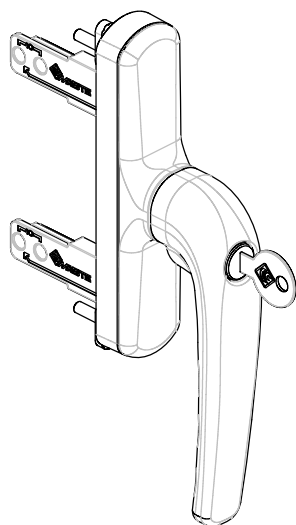
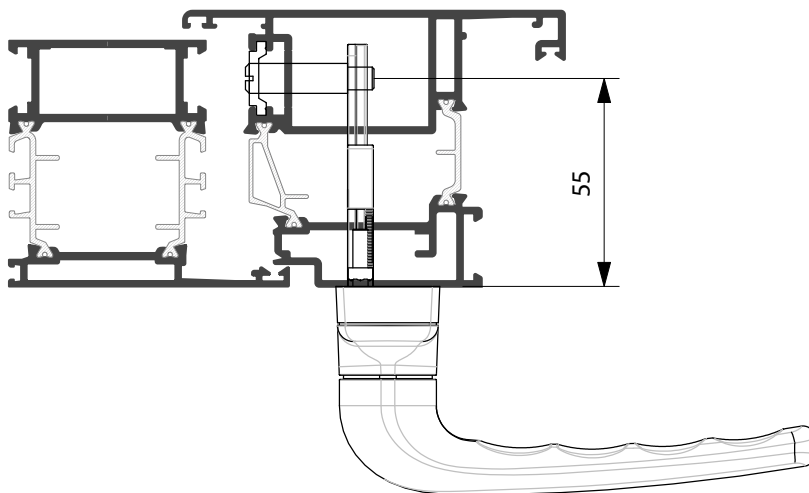

ARX.03.48
Cremonese Apertura esterna
con chiave - int. 37/65mm
Cremonese bolt external
opening with cylinder lock - int.
37/65mm

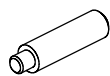
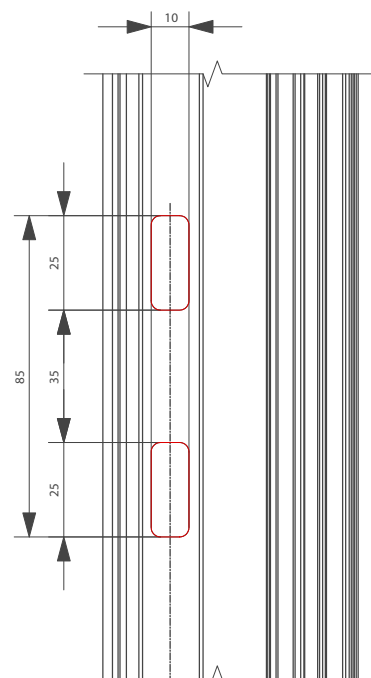
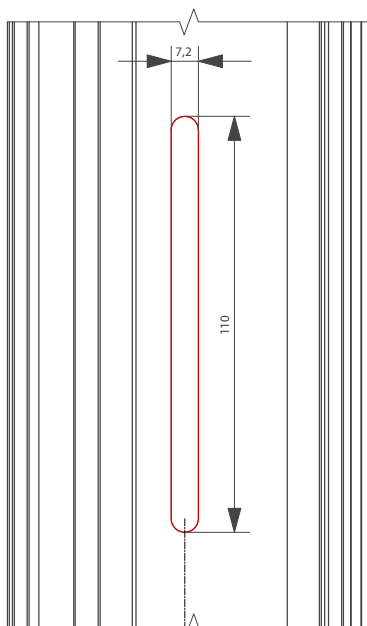

ACX.03.67
Perno di trascinamento
L=27mm
Winding pivot L=27 mm

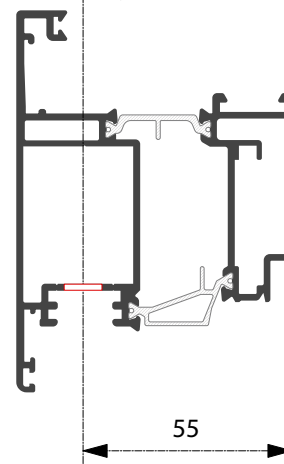
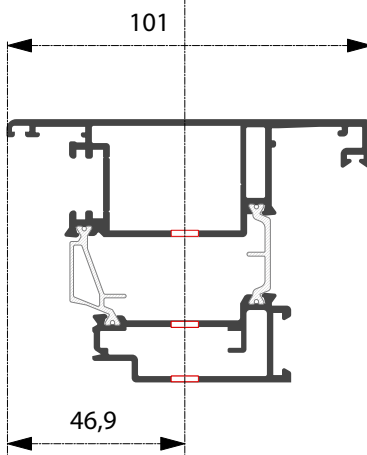

Applicazione Accessori

Application of Accessories

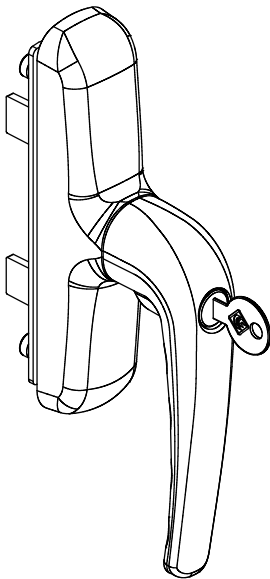

ARX.03.07
Cremonese con chiave
Interasse 84 - 92 - 104 mm
*Cremonese bolt with cylinder
lock - Int. 84/92/104mm*

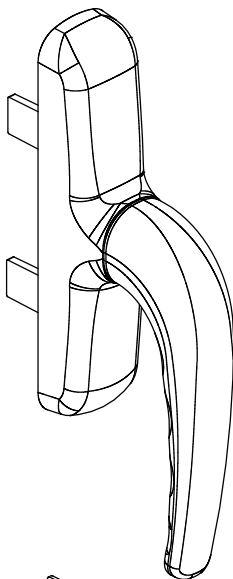
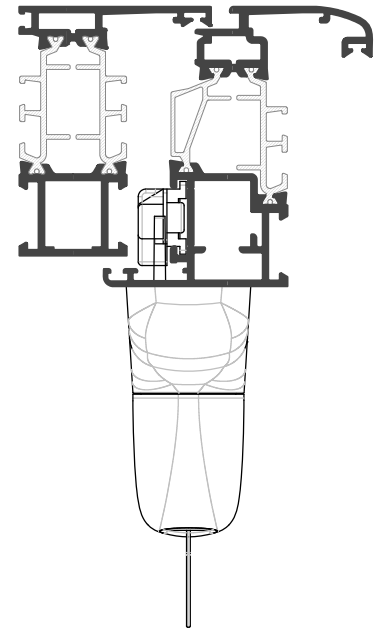
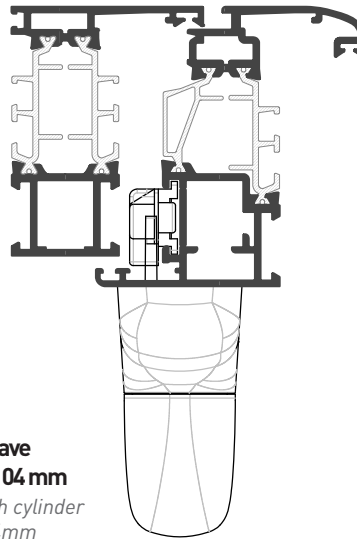

ARX.03.06
Cremonese
Interasse 84 - 92 - 104 mm
*Cremonese bolt
- Int. 84/92/104mm*

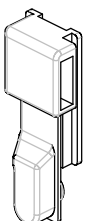
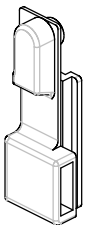
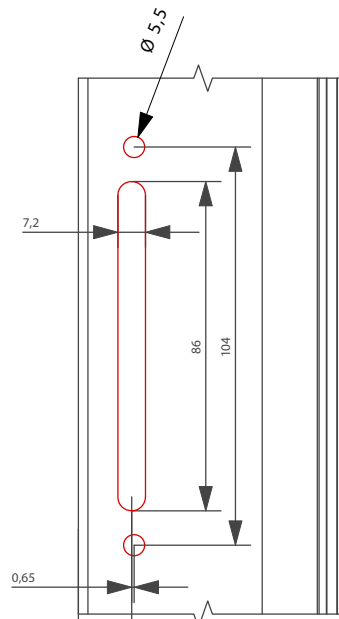

ACX.03.17
Innesti Cremonese
Cremonese Winding pivot

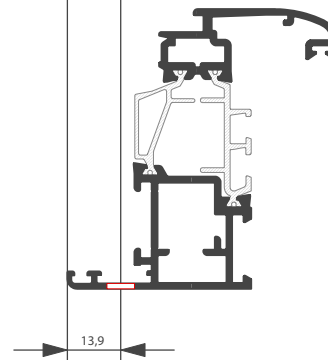

Applicazione Accessori

Application of Accessories

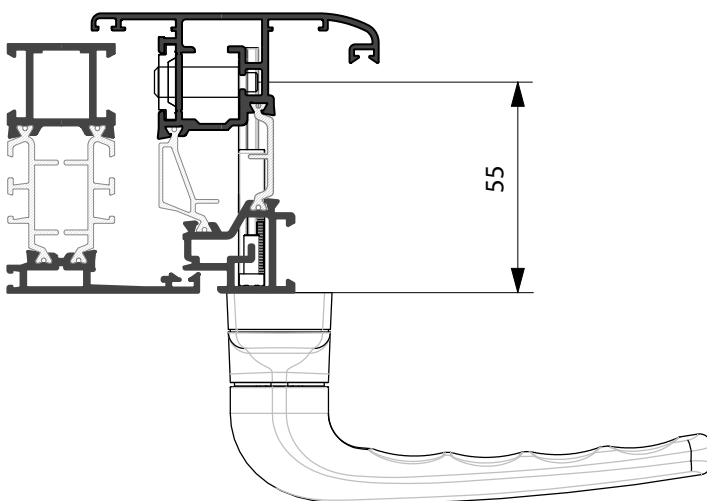
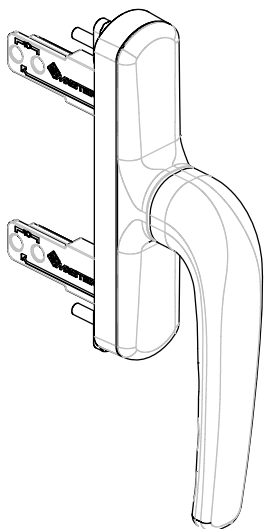

ARX.03.50
Cremonese Apertura
esterna - int. 37/65mm
*Cremonese bolt external
opening - int. 37/65mm*

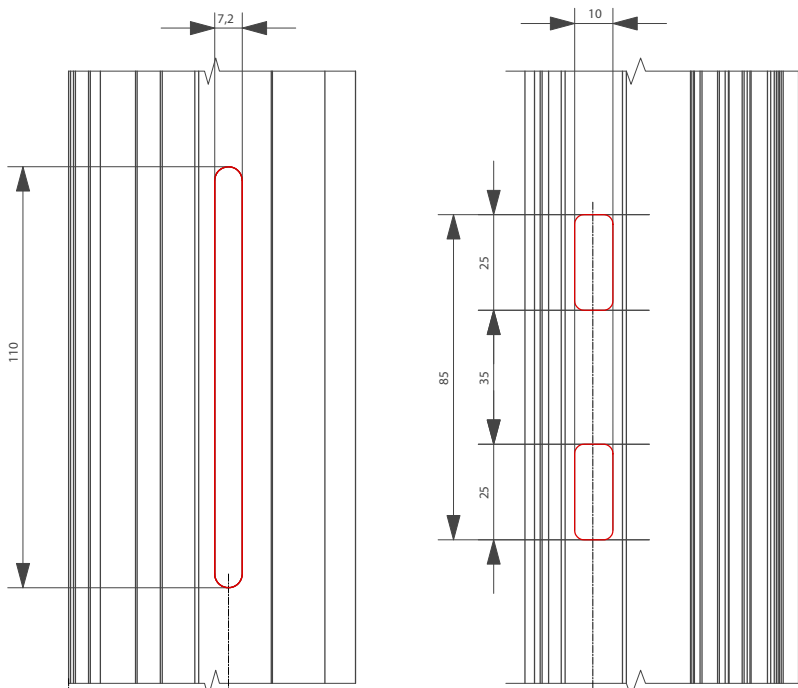
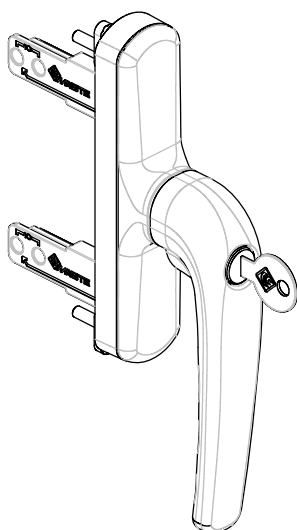

ARX.03.48
Cremonese Apertura esterna
con chiave - int. 37/65mm
*Cremonese bolt external
opening with cylinder lock - int.
37/65mm*

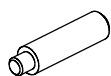

ARX.03.45
Perno di trascinamento
L=22 mm
Winding pivot L=22 mm

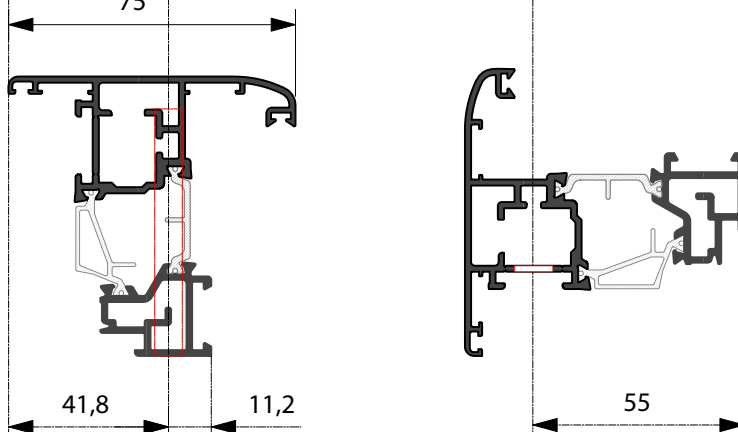

Applicazione Accessori

Application of Accessories

ACCESSORI MOTORIZZAZIONE
MOTORIZATION ACCESSORIES

ACX.20.05
Attuatore a catena da incasso
Concealed chain actuator

1pz. ACX.20.05 step 1200mm
1pcs ACX.20.05 step 1200mm

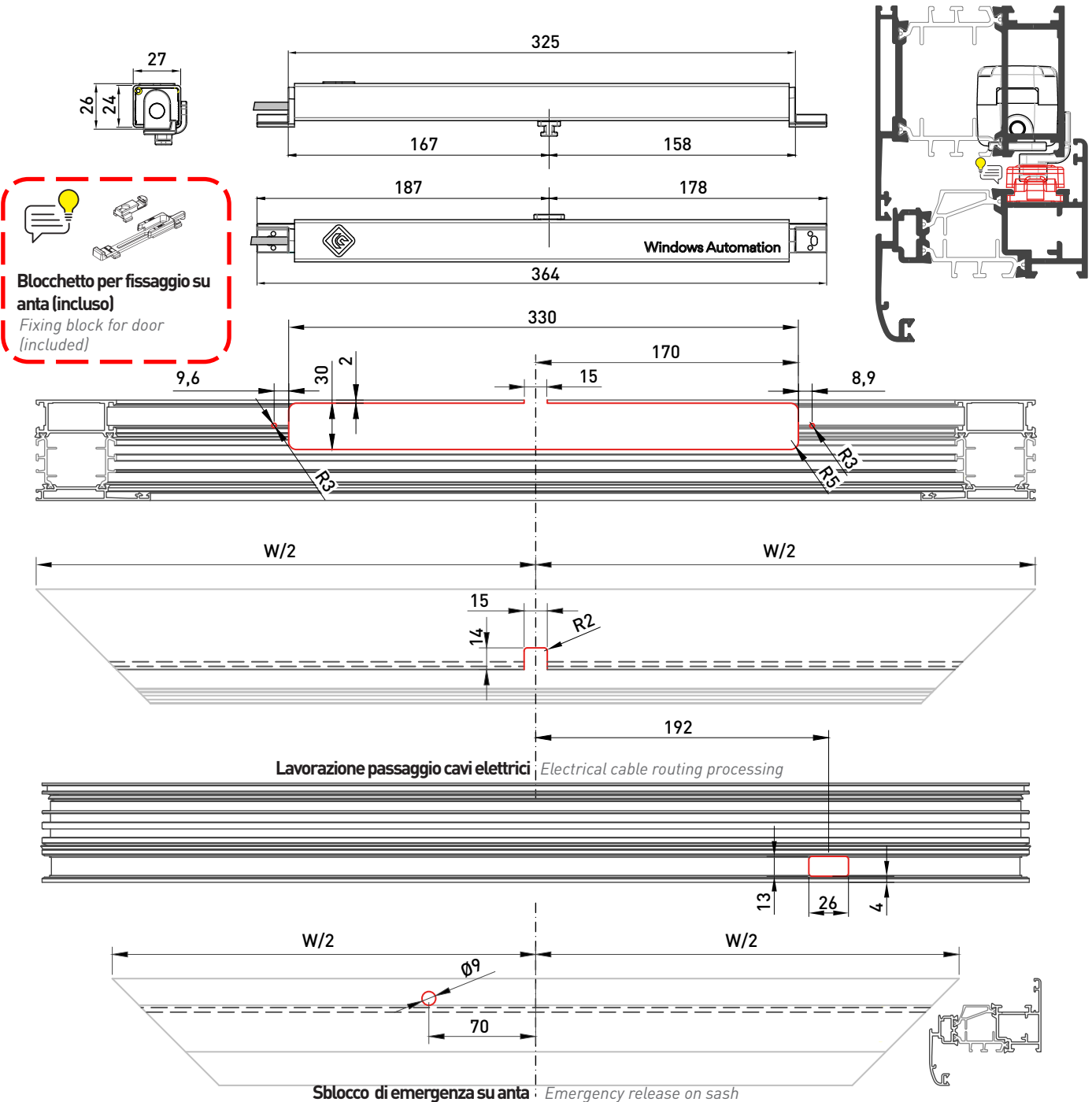

ACX.20.09
Braccio limitatore per anta Vasistas
Restrictor arm for hung opening

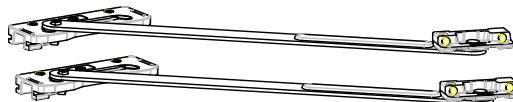

NB. Maggiori dettagli di montaggio nella confezione

N.B. More details about assembly in the package

Applicazione Accessori

Application of Accessories

ACCESSORI MOTORIZZAZIONE
MOTORIZATION ACCESSORIES

ACX.20.06
Serratura elettromeccanica
Electromechanical lock

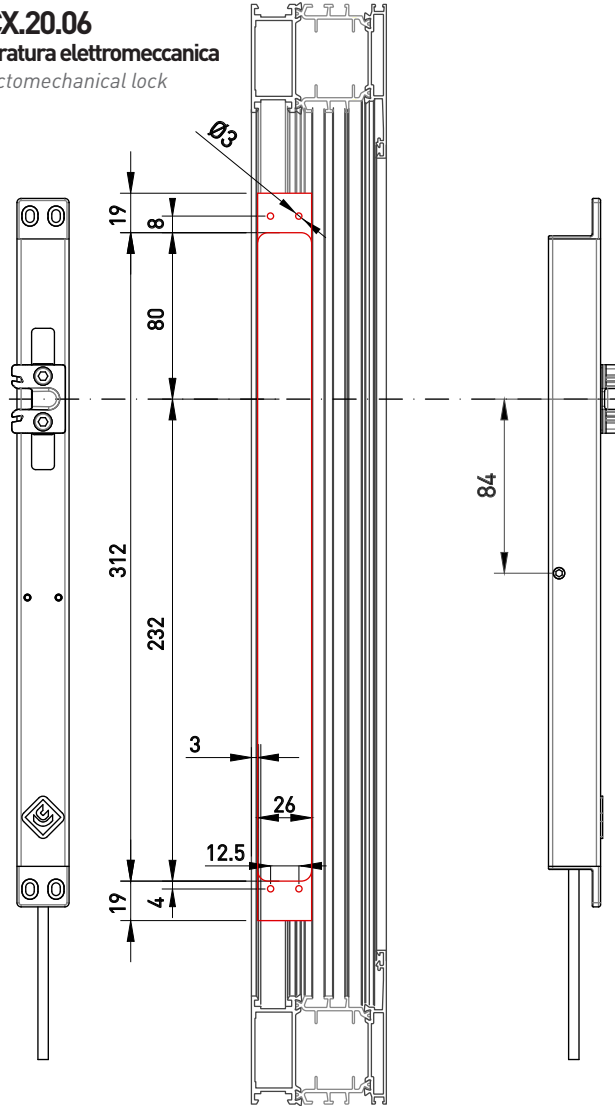

Lavorazione sblocco manuale
Tooling for manual release

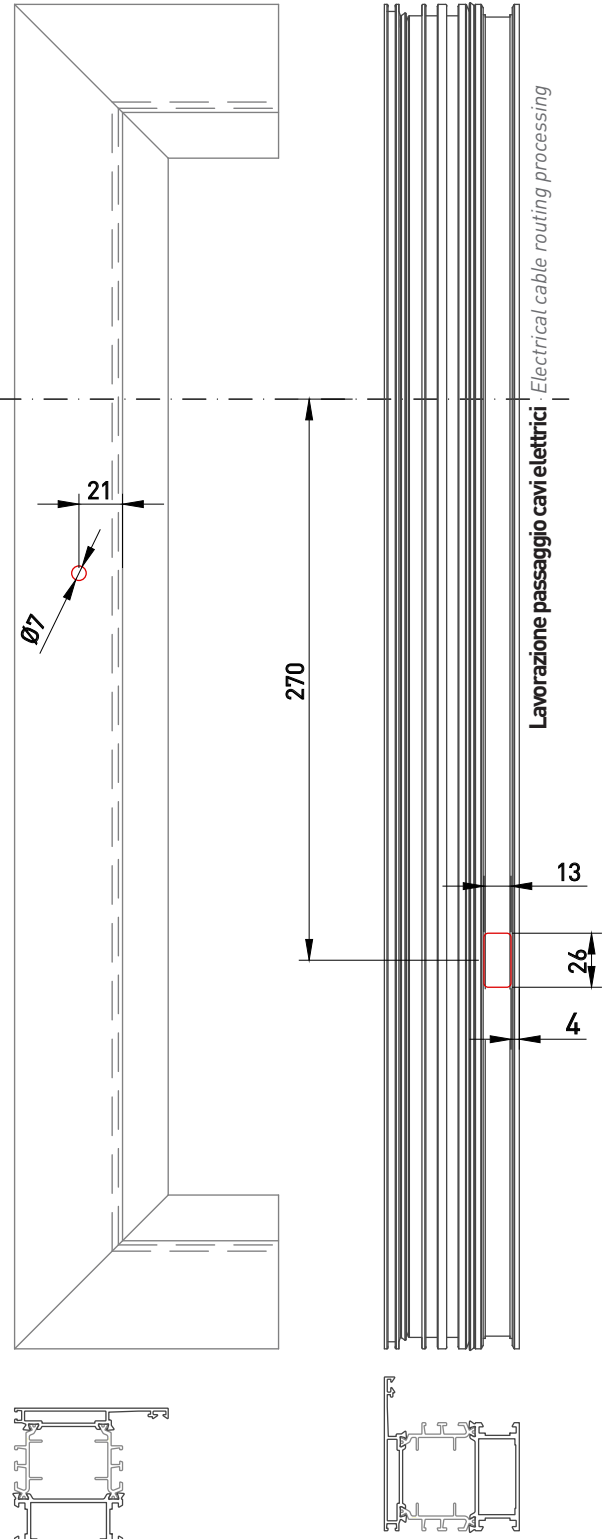

ACX.20.08
Sensore pioggia
Heated rain sensor

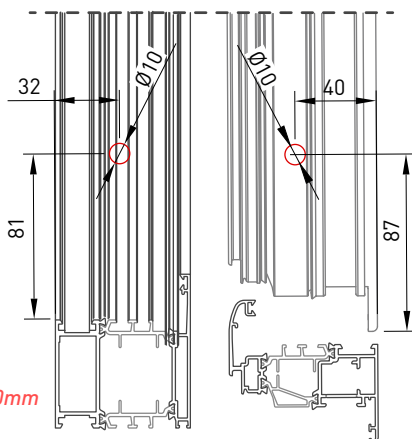
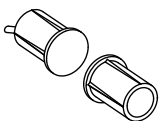

**NB: posizionamento fori
indicativo - foro 10mm**
NB: free position - hole 10mm

NB: VITI DI FISSAGGIO NON FORNITE NELLA CONFEZIONE. VITE AUTOFILETTANTE Ø 3.9mm
N.B. FIXING SCREWS NOT SUPPLIED IN THE PACKAGE. SELF-TAPPING SCREW Ø 3.9mm

Applicazione Accessori

Application of Accessories

ACCESSORI MOTORIZZAZIONE
MOTORIZATION ACCESSORIES

ACX.20.07
Kit base anta ribalta autotmatica
Base kit for automatic tilt-turn

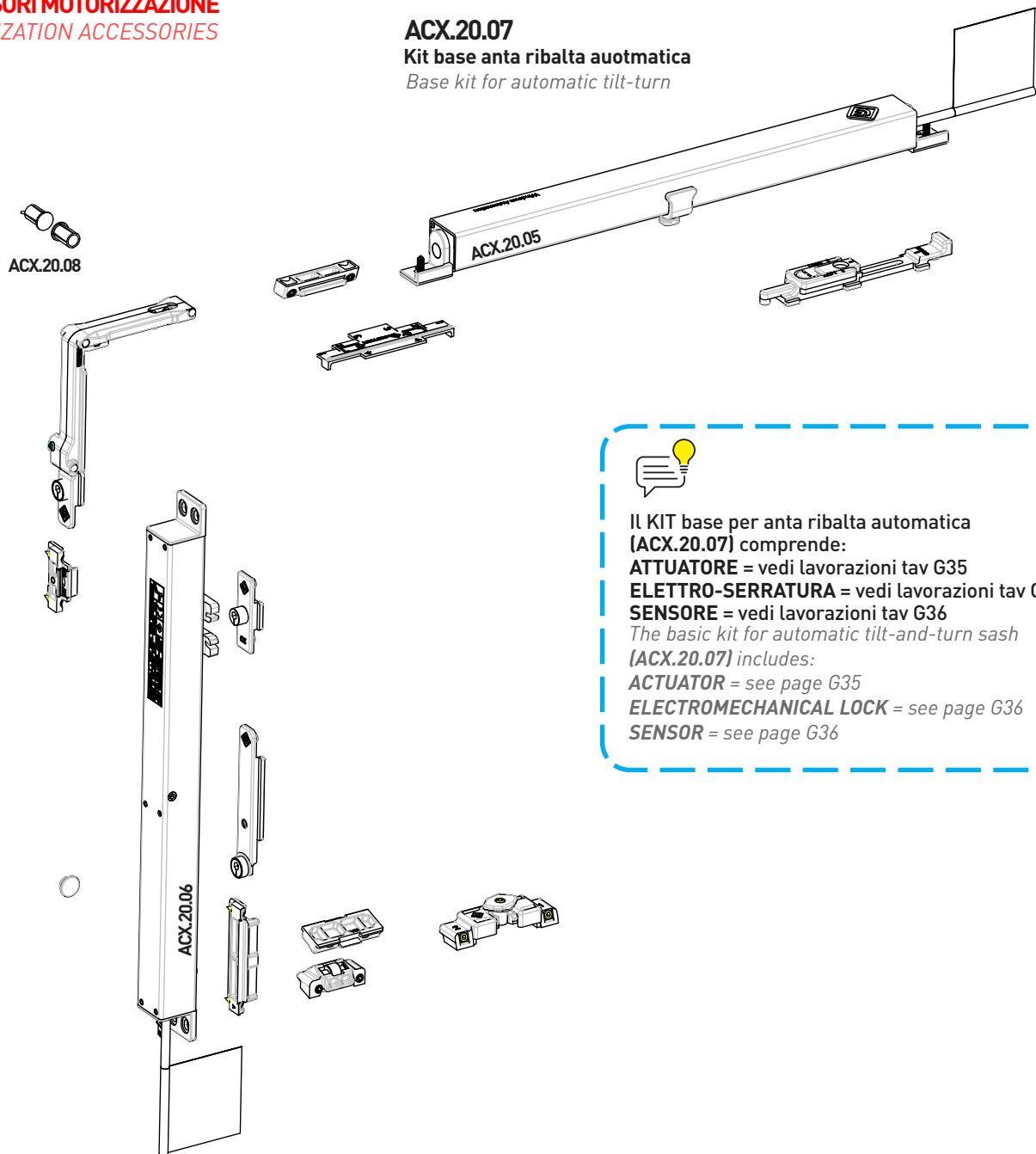

Il KIT base per anta ribalta automatica (ACX.20.07) comprende:
ATTUATORE = vedi lavorazioni tav G35
ELETTRO-SERRATURA = vedi lavorazioni tav G36
SENSORE = vedi lavorazioni tav G36
 The basic kit for automatic tilt-and-turn sash (ACX.20.07) includes:
ACTUATOR = see page G35
ELECTROMECHANICAL LOCK = see page G36
SENSOR = see page G36

SOLUZIONI PER MOTORIZZAZIONE:
SOLUTIONS FOR MOTORIZATION:

TIPOLOGIA / TYPE	ACX.20.05 Attuatore actuator	AC.X20.06 Elettro-serratura Electromechanical lock	ACX.20.07 Kit anta ribalta automatical Kit automatic Tilt-Turn	ACX.20.08 Sensore pioggia rain sensor	ACX.20.09 Braccio limitatore restrictor arm
VASISTAS	X				X
VASISTAS+ CHIUSURE PERIMETRALI	X	X		X	
ANTA RIBALTA			X		

NB. Maggiori dettagli di montaggio nella confezione | N.B. More details about assembly in the package



MILLING UNITS

GRFW27CAS3553

Gruppo Frese CX550/650
Traversi/telaio-ante e FN
*Crosspiece/door frame milling unit
CX550/650 TAPE HW*

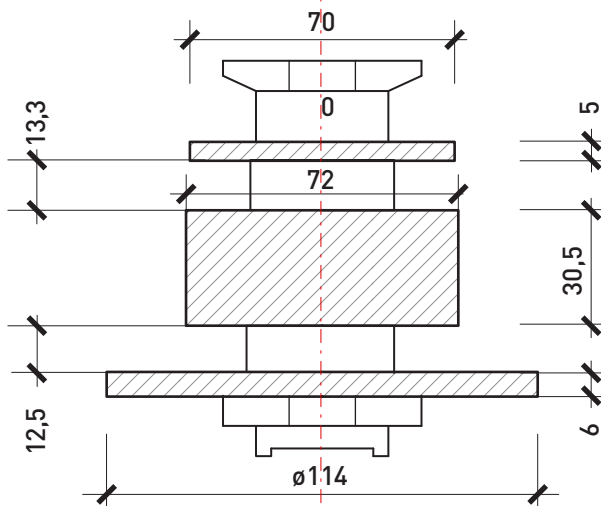

GRFW28CAS3553

Gruppo Frese ante complanari
Incluso distanziali per trasformarla in
Gruppo Frese ante ferramenta a nastro
Gruppo Frese trav/telaio-ante
*Milling unit for coplanar sashes
spacer included for TAPE HW transformation.
Crosspiece/door frame milling unit.*

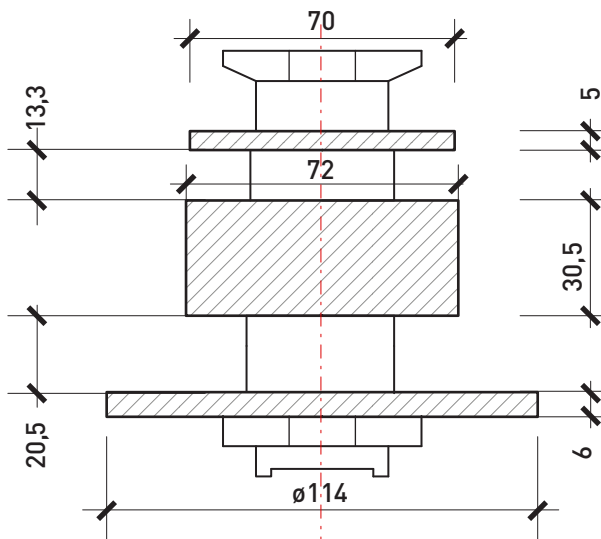

GRFW29CAS3553

Gruppo Frese CX550/650
Ferramenta a nastro
Milling unit CX550/650 TAPE HW

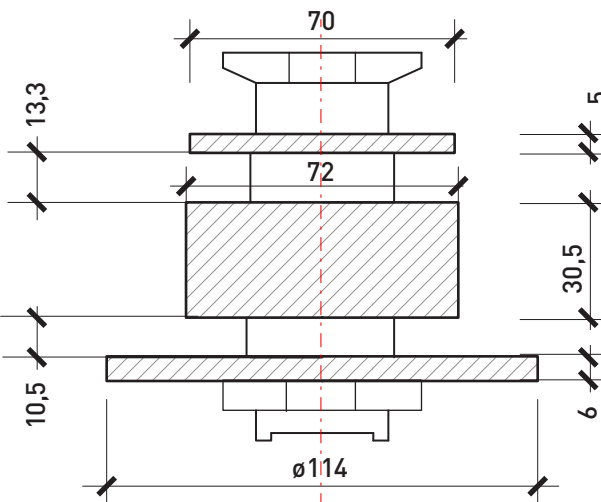



MILLING UNITS

GRFW30CAS3553

Gruppo Frese CX550/650

Ante aperture esterne

Milling unit CX550/650 TAPE HW for EXT

Opening Sashes

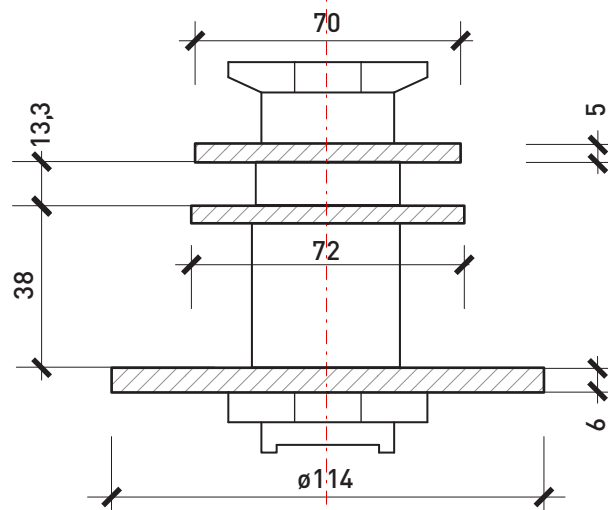

GRFW31CAS3553

Gruppo Frese CX550/650

Ante vetro infilare

Milling unit CX550/650 for insert glass

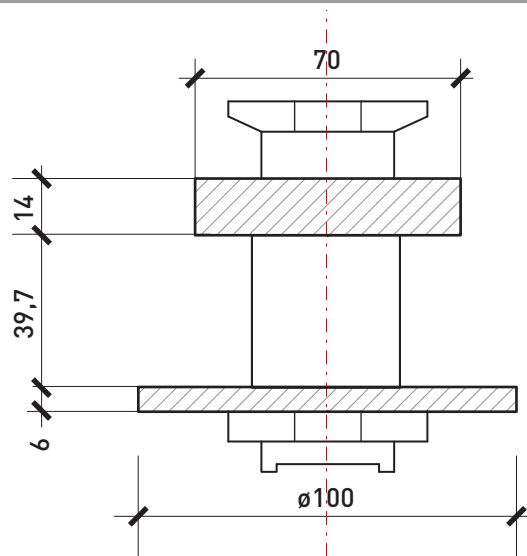

Applicazione Accessori

Application of Accessories

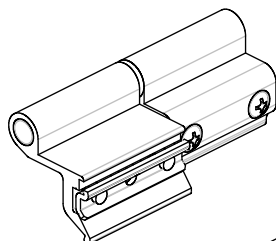

ACX.02.01
Cerniera a montaggio rapido a 2 ali
Rapid assembly 2-leafed hinge

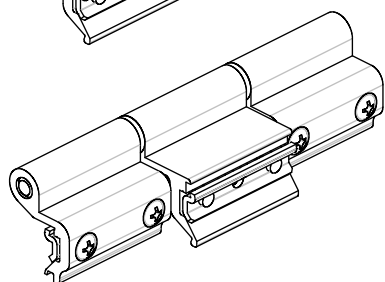

ACX.02.03
Cerniera a montaggio rapido a 3 ali
Rapid assembly 3-leafed hinge

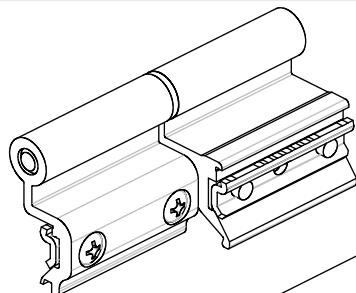
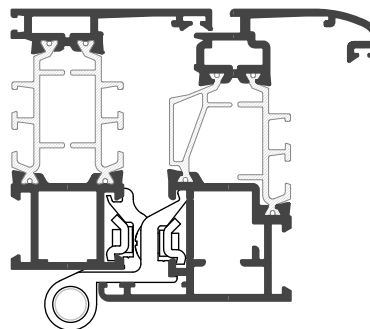

ACX.02.02
Cerniera a montaggio rapido a 2 ali
Rapid assembly 2-leafed hinge

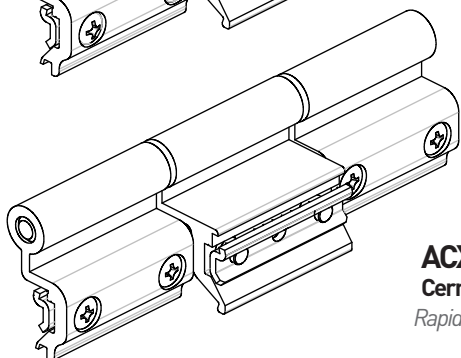

ACX.02.04
Cerniera a montaggio rapido a 3 ali
Rapid assembly 3-leafed hinge

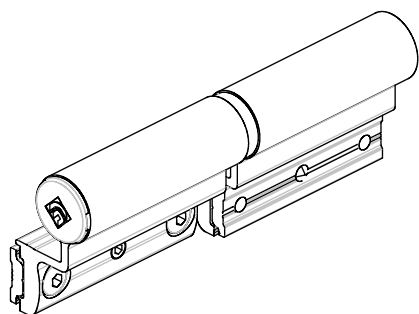
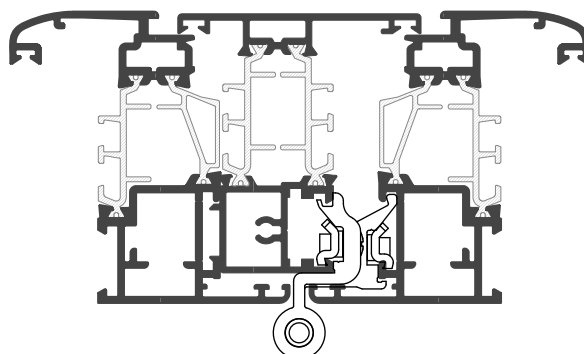

ACX.02.11
Cerniera porte a 2 ali
Rapid assembly 2-leafed hinge

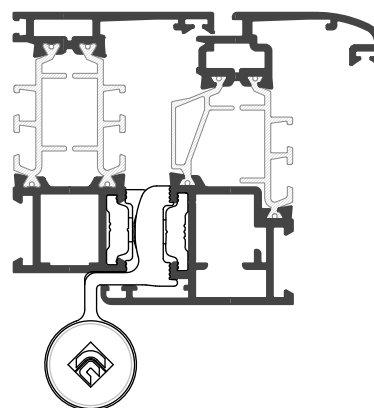

Applicazione Accessori

Application of Accessories

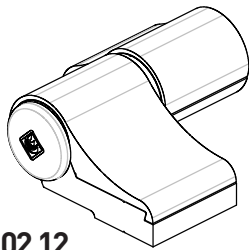
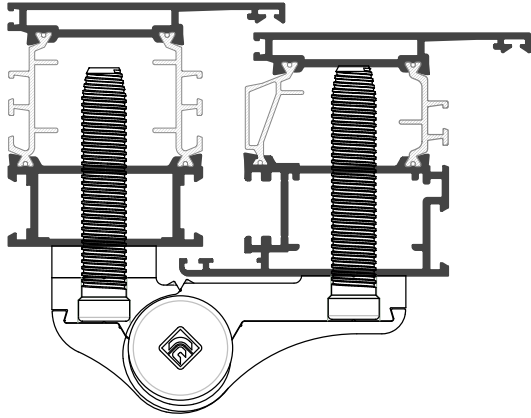

ARX.02.12

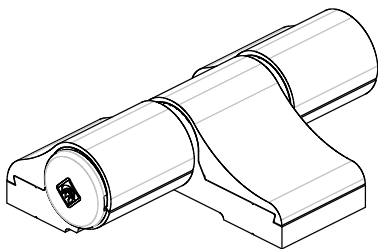

ARX.02.13

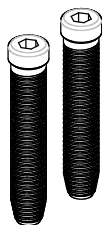

ARX.02.23

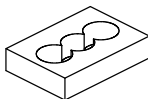

ARX.02.25

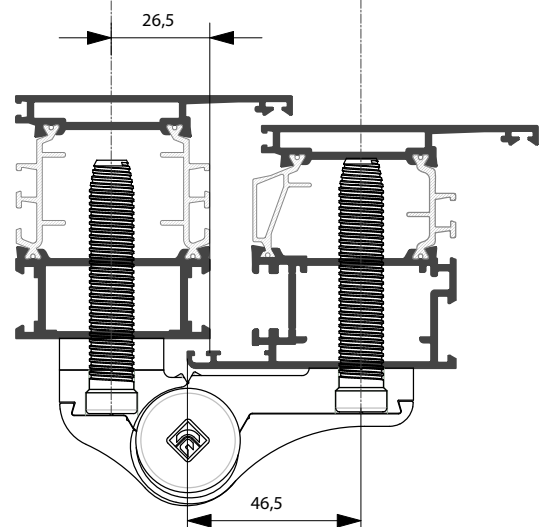
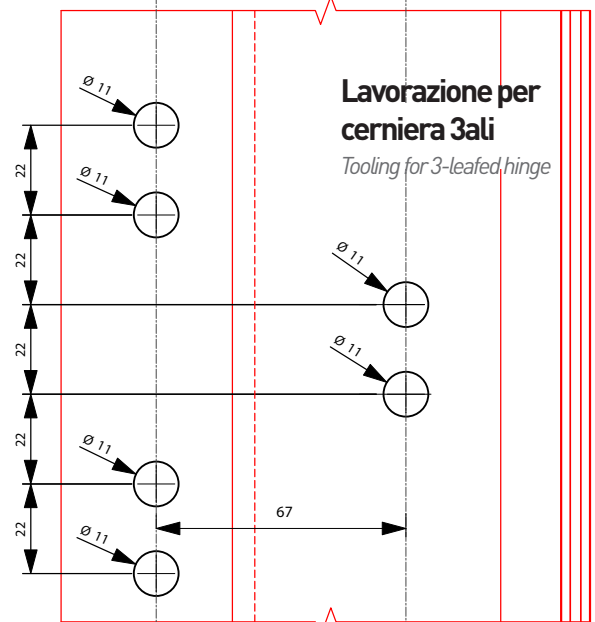
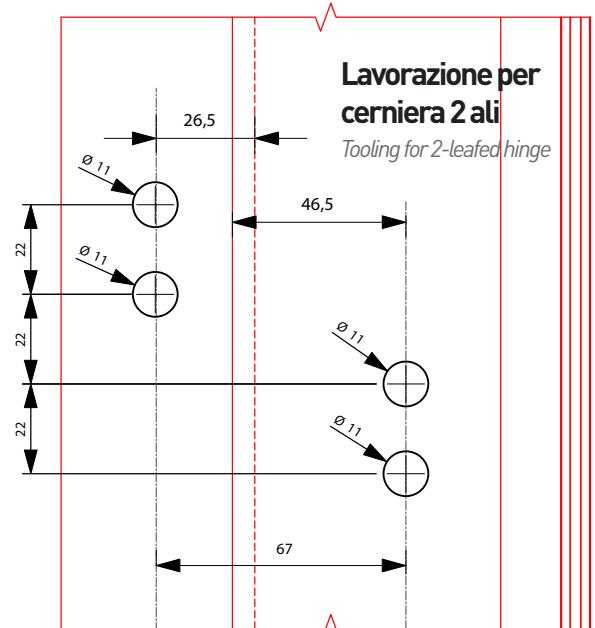

Applicazione Accessori

Application of Accessories

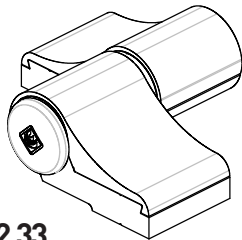
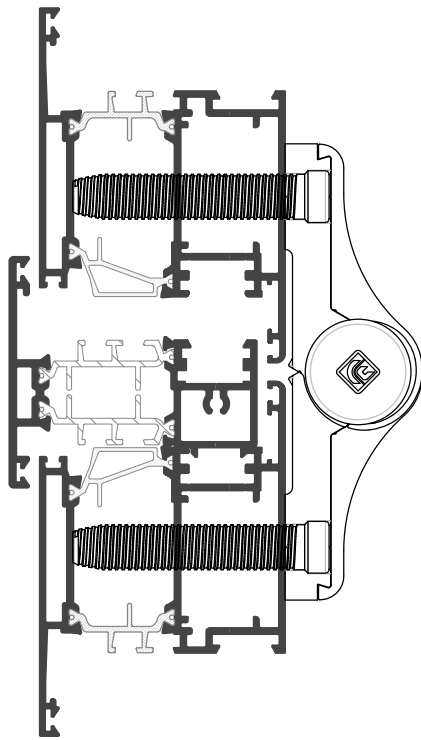

ARX.02.33

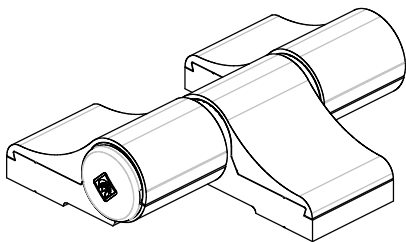

ARX.02.34

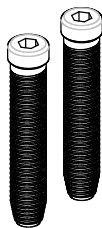

ARX.02.23

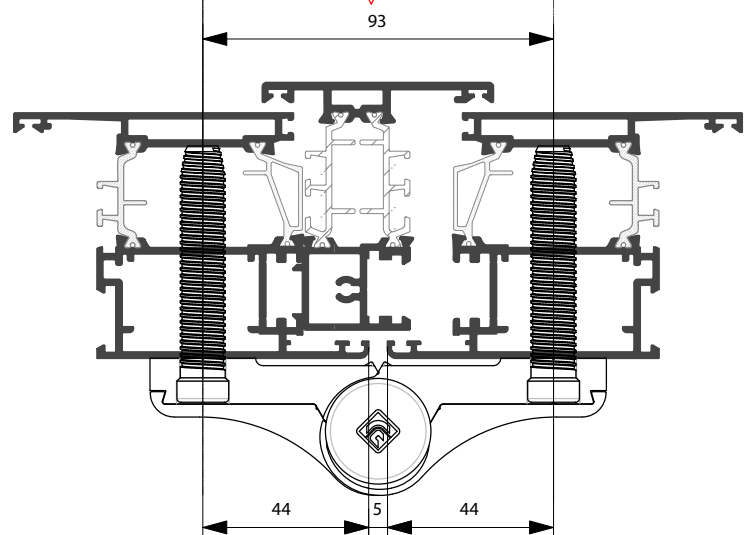
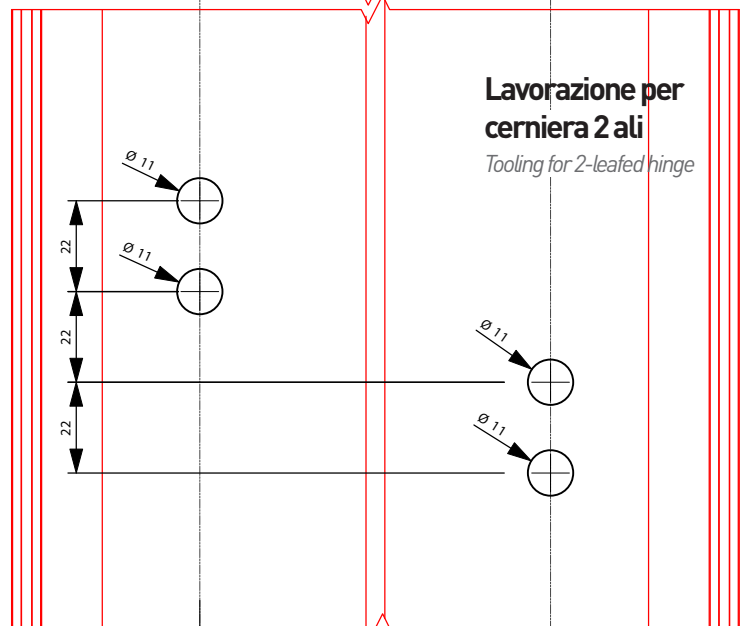
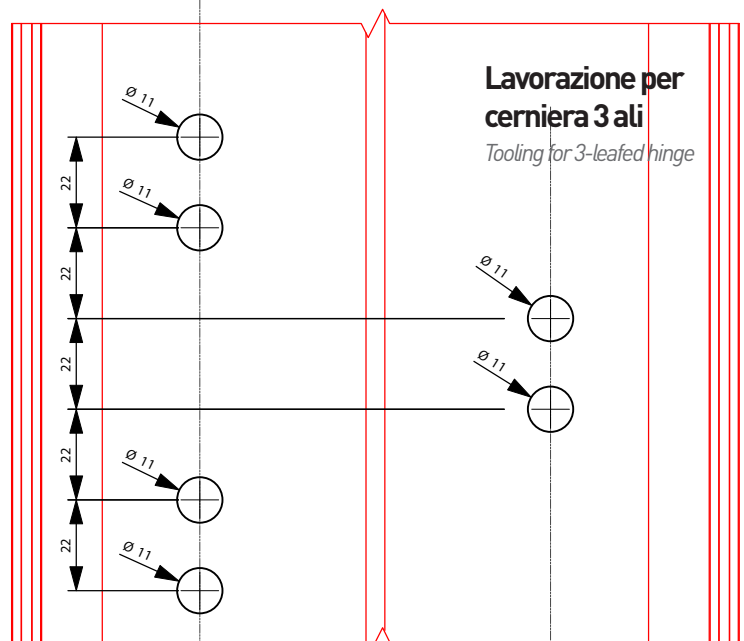

Applicazione Accessori

Application of Accessories

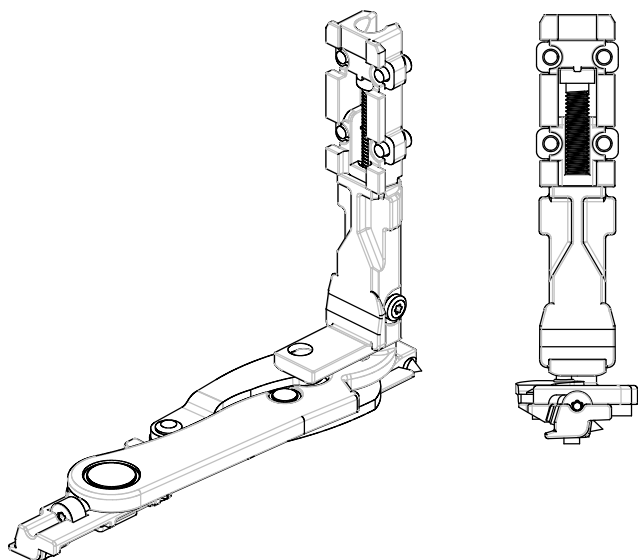

ACX.08.39
WEEN HIDE 180- Sx/Dx Cerniera inferiore
WEEN HIDE 180- Bottom Left/Right Hinge

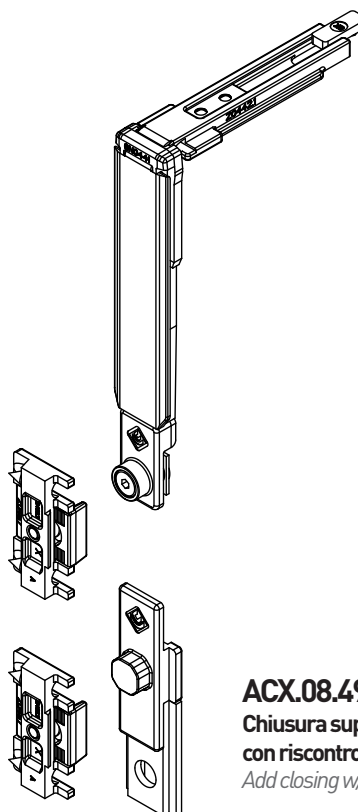

ACX.08.49
Chiusura supplementare laterale con riscontro regolabile
Add closing w/adjustable counterplate

ACX.08.36
WEEN HIDE 180- Dx Braccio a scomparsa per apertura a battente
WEEN HIDE 180- Right retractable arm for hinged opening

ACX.08.37
WEEN HIDE 180- Sx Braccio a scomparsa per apertura a battente
WEEN HIDE 180- Left retractable arm for hinged opening

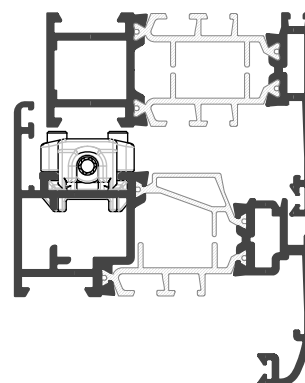
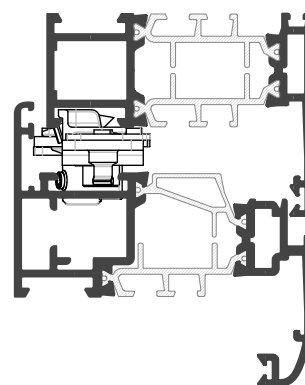
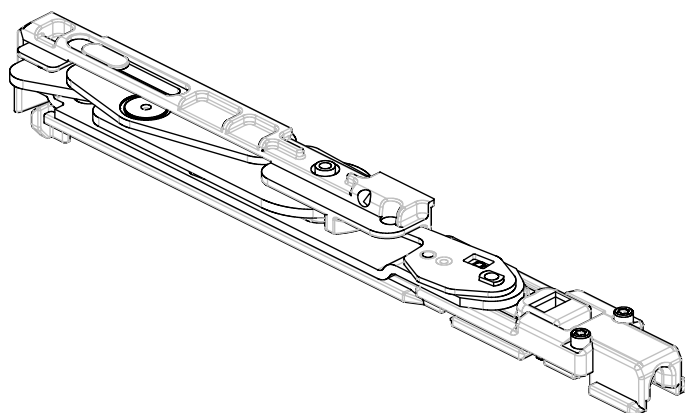

Applicazione Accessori

Application of Accessories

ACX.08.40
Ween hide 180
kit base anta ribalta con anti falsa manovra sulla
cremonese ante CX65.201 e CX65.202 e CX65.203 e similari
tilt&turn window base kit with wrong counter-actuation on the Cremonese bolt

RIBALTA
Folding

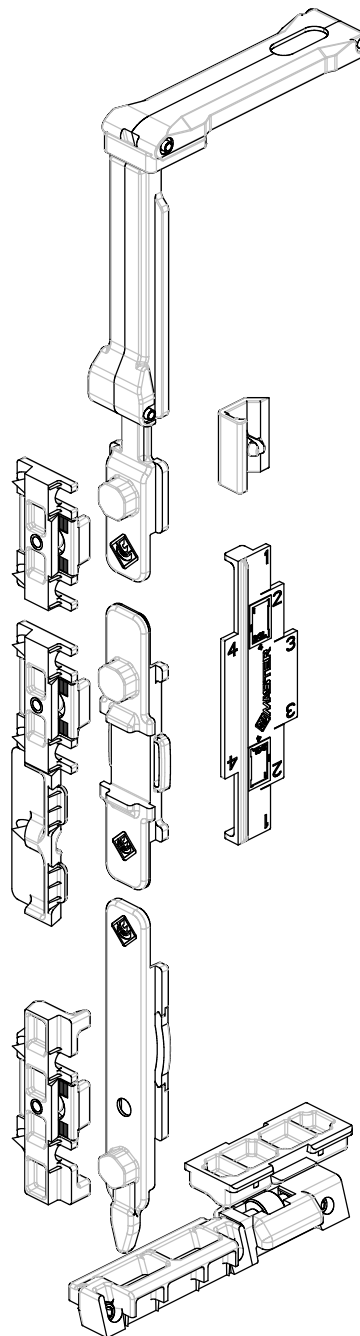
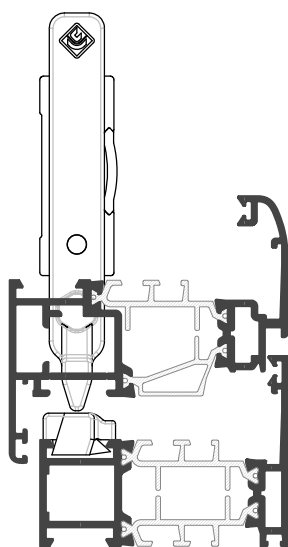
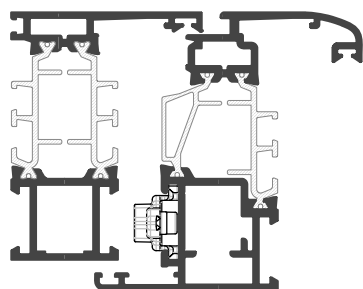
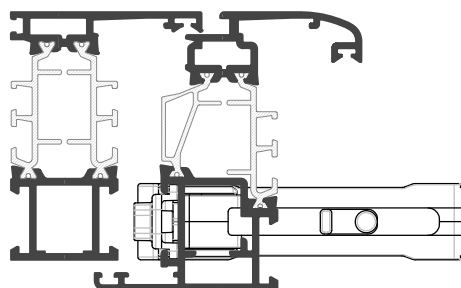

Applicazione Accessori

Application of Accessories

ACX.08.41
Ween hide 180
kit base anta ribalta con anti falsa manovra sulla
cremonese

tilt&turn window base kit with wrong counter-actuation on the
Cremonese bolt

RIBALTA
Folding

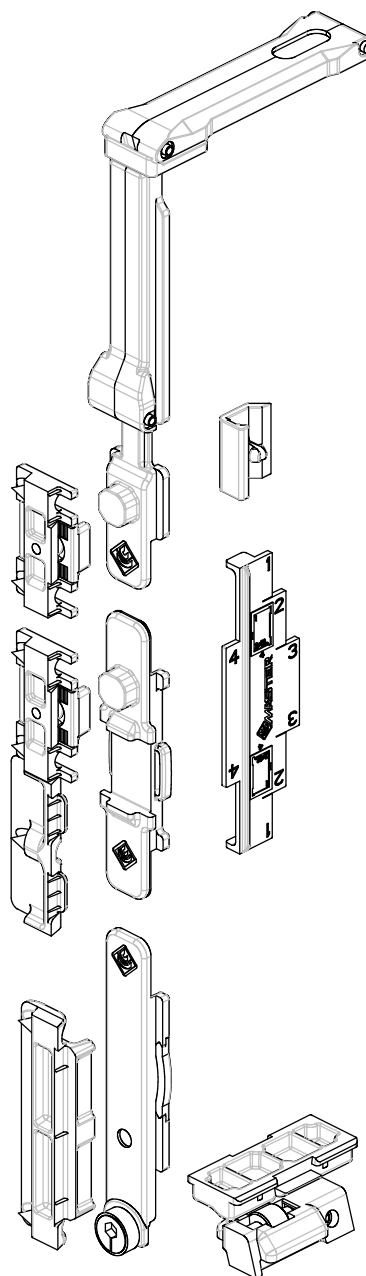
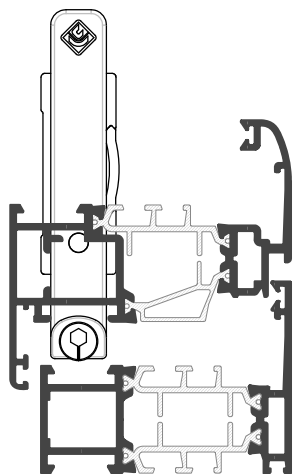
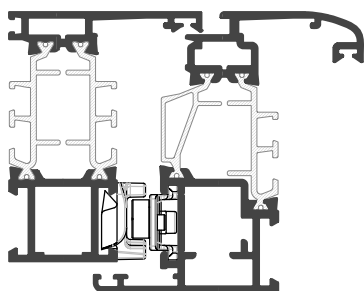
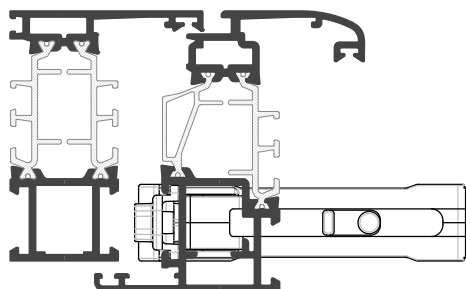

Applicazione Accessori

Application of Accessories

ACX.08.01
Kit base anta ribalta
Portata massima 160Kg

tilt&turn window base kit Maximum Load 160Kg

RIBALTA
Folding

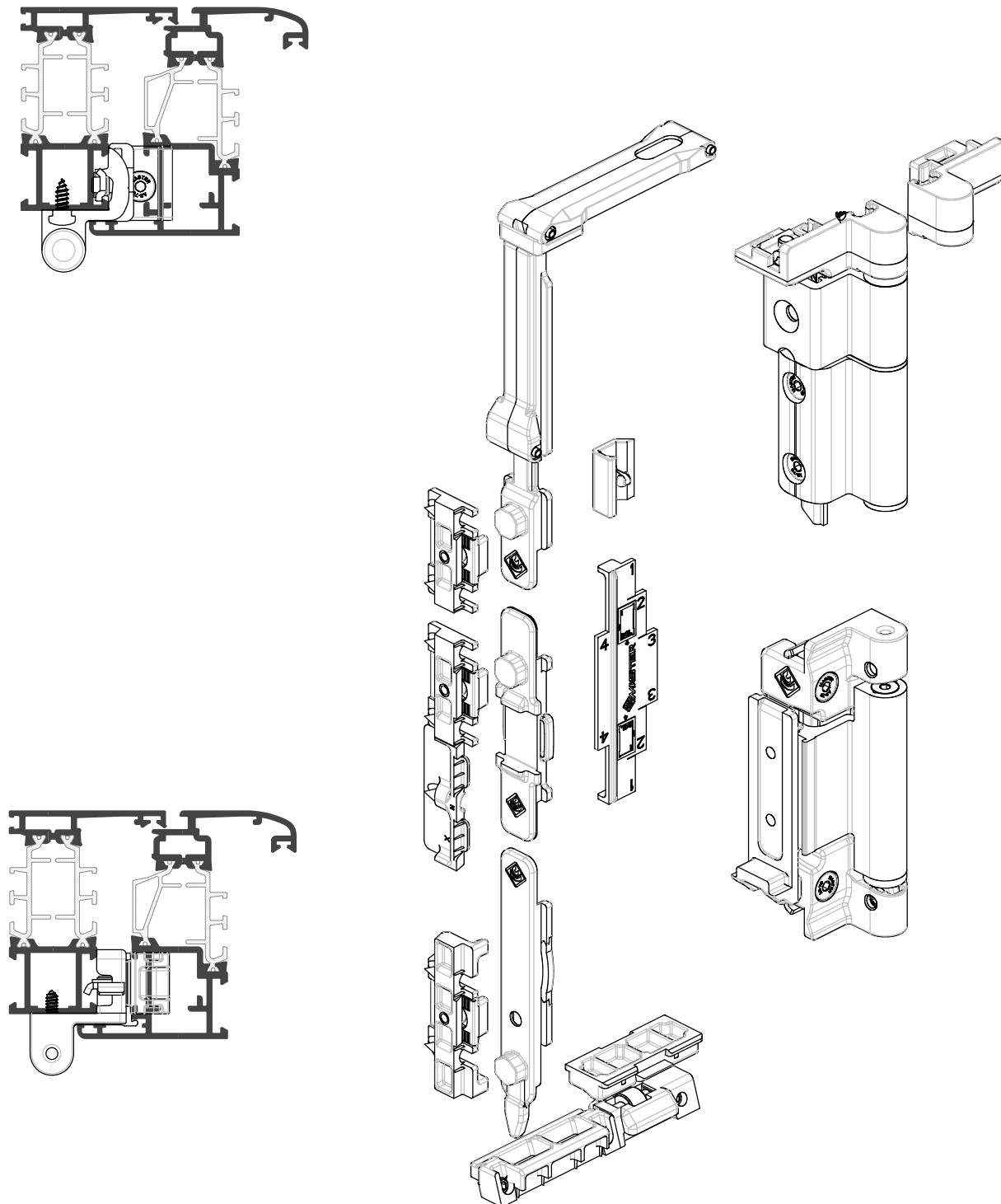

Applicazione Accessori

Application of Accessories

RIBALTA
Folding

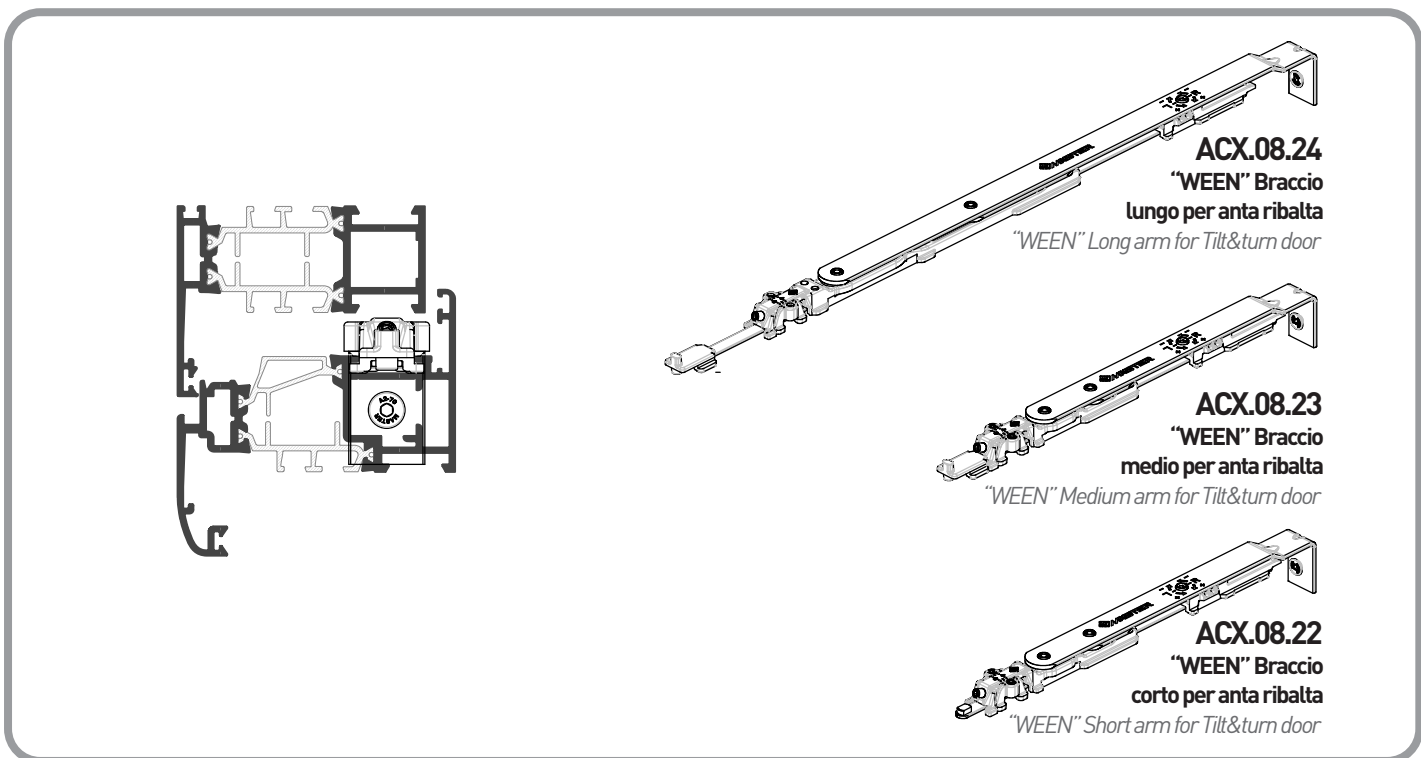
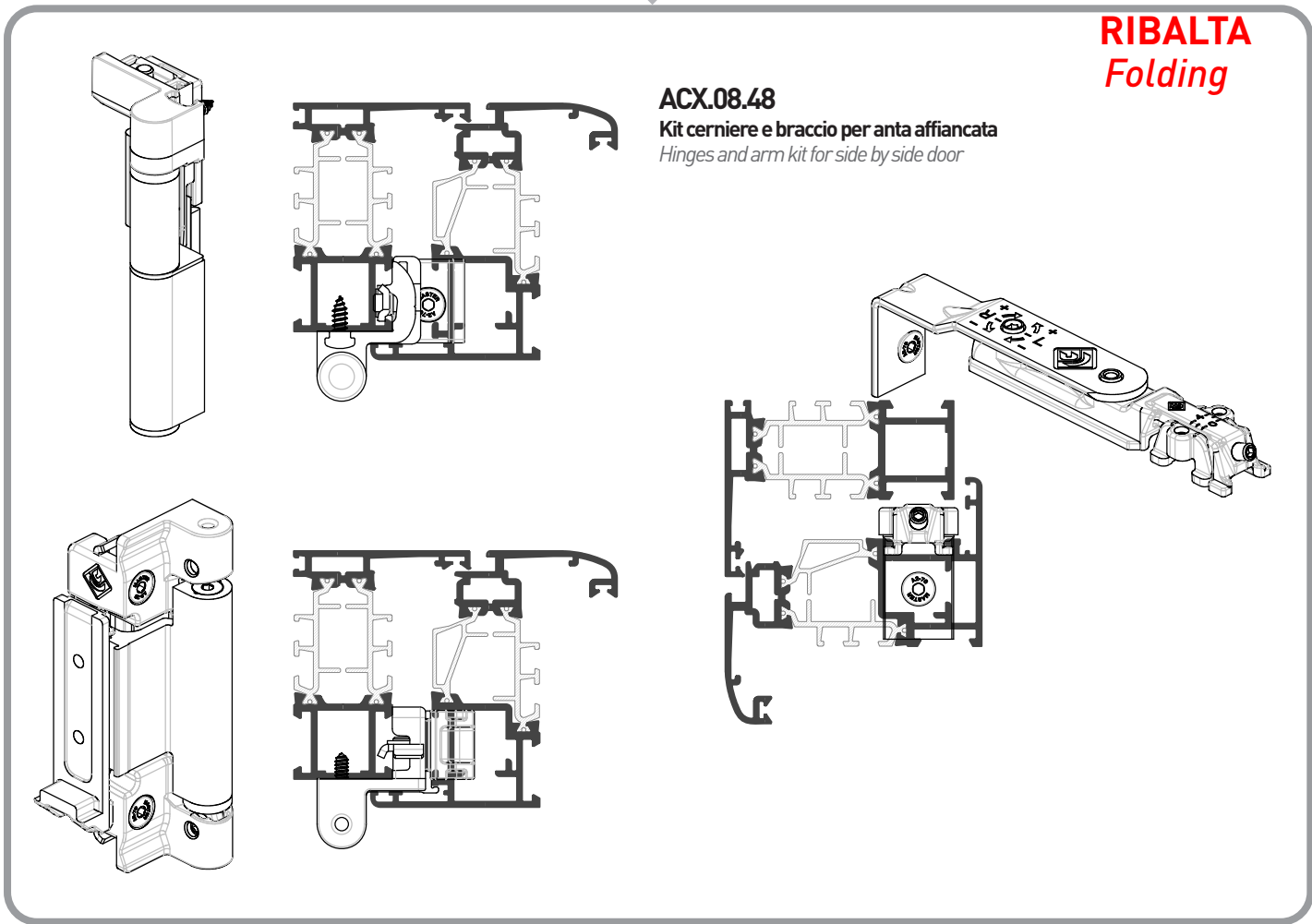

Applicazione Accessori

Application of Accessories

RIBALTA
Folding

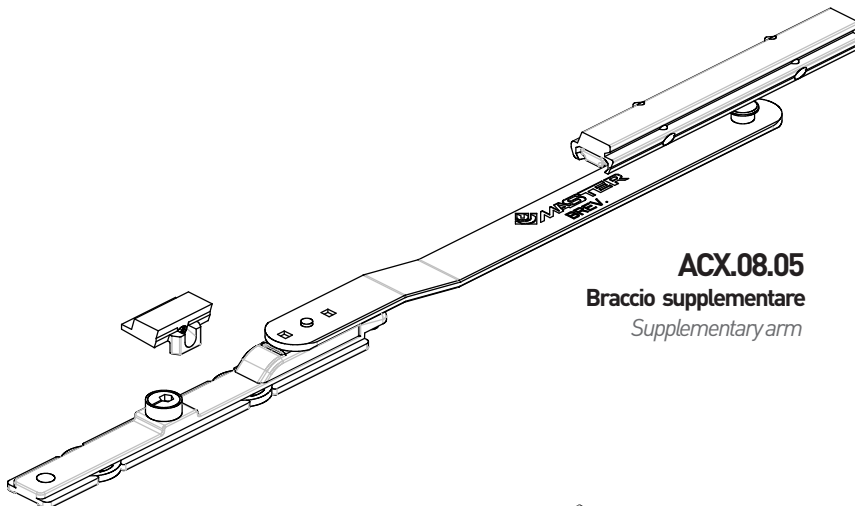
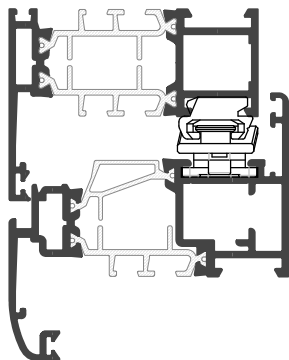

ACX.08.05
Braccio supplementare
Supplementary arm

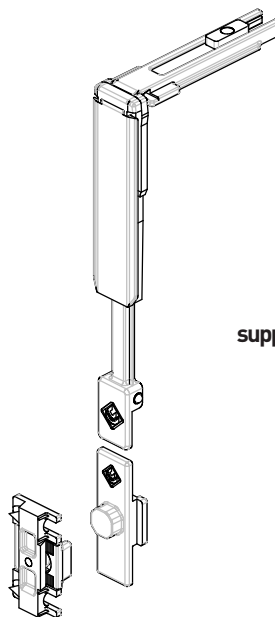
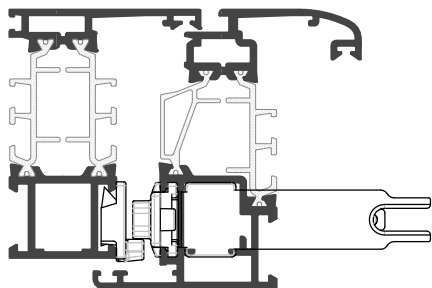

ACX.08.06
"WEEN" Chiusura
supplementare orizz./vert.
*"WEEN" Supplementary
Horizontal/Vert.*

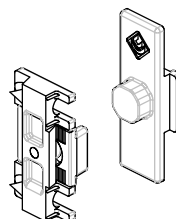
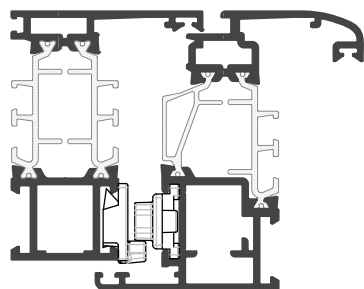

ARX.08.16
"WEEN" Punto
chiusura supplementare
*"WEEN" Supplementary
closing point*

Applicazione Accessori

Application of Accessories

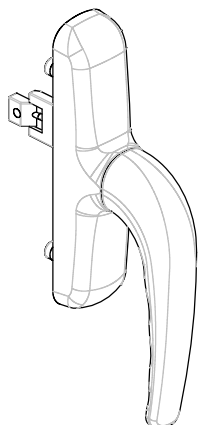

ARX.03.08
Cremonese per anta ribalta
Cremonese bolt for Tilt&turn door

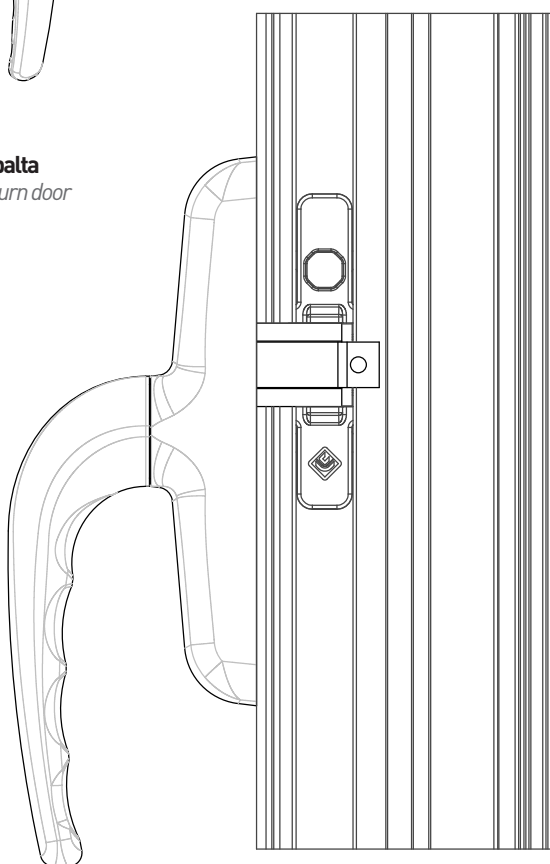

RIBALTA
Folding

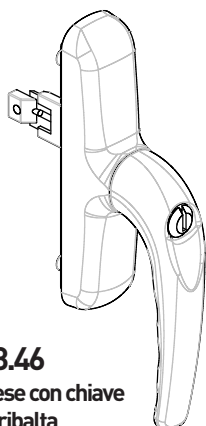
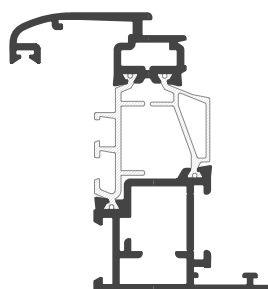
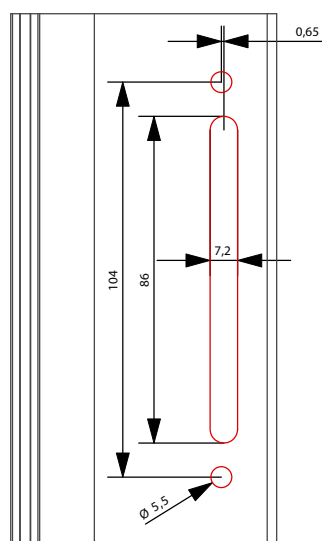

ARX.03.46
Cremonese con chiave
per anta ribalta
*Cremonese bolt with cylinder lock
for Tilt&turn door*

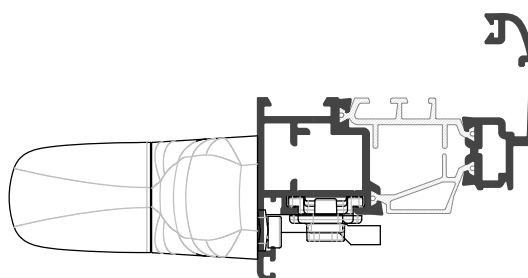

Applicazione Accessori

Application of Accessories

- Indicazioni per foratura traversi

- Indications for drilling crosspieces

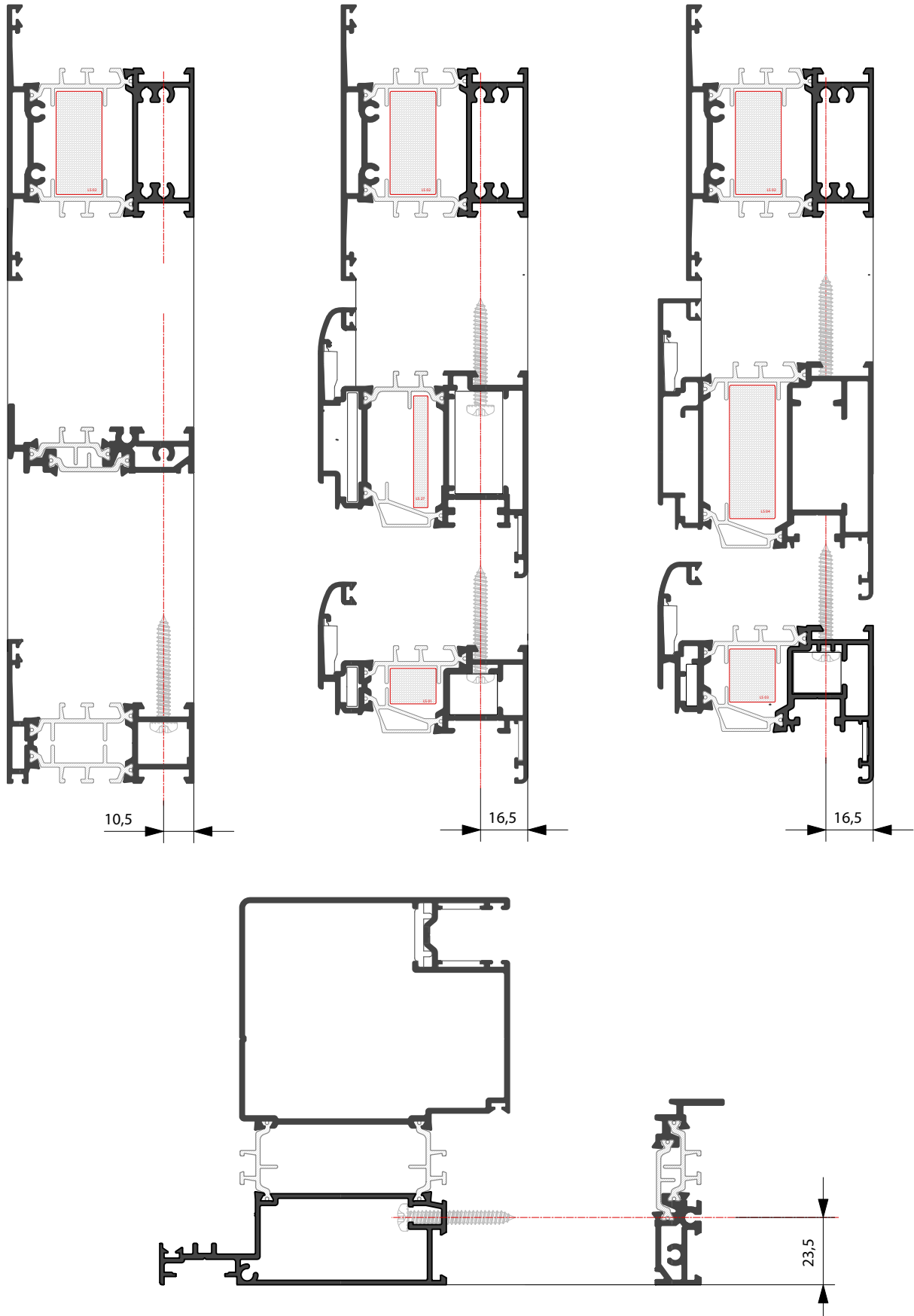

Applicazione Accessori

Application of Accessories

- Indicazioni per foratura traversi

- Indications for drilling crosspieces

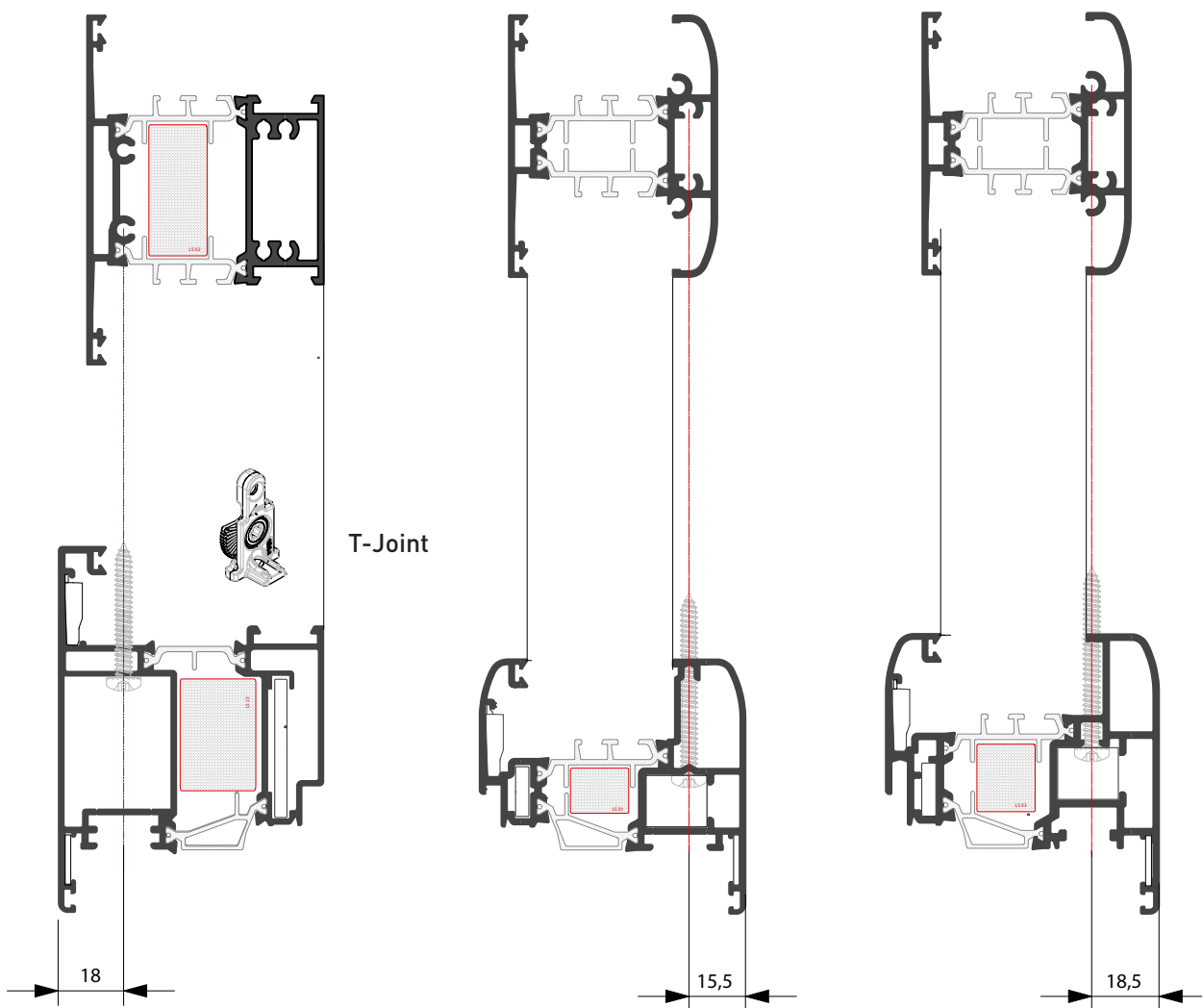



1 ANTA
1 Sash

Contropiastra Regolabile in Metallo			
A-B	C	D	E
06463-32	06465-22	06463-32 (17)	06465-22 (pz.2)
(17) = inserto rullo art. 06141-71			

CILINDRO SAGOMATO (Nichelato Fin.12)		Frontale
con borchie	senza borchie	
0E300-20-0-12 L=89 (29.5-59.5)	0E300-33-0-12 L=84 (29.5-54.5)	22x3

E= 35 mm

Art.19225
Art.49225
Art.49225
Art.49250
Art. 06443-31/36-0

2 ANTE
2 Sashes

Contropiastra Regolabile in Metallo			
A-B	C	D	E
06463-32	06465-22	06463-32 (17)	06465-22 (pz.2)
(17) = inserto rullo art. 06141-71			

CILINDRO SAGOMATO (Nichelato Fin.12)		Frontale
con borchie	senza borchie	
0E300-20-0-12 L=89 (29.5-59.5)	0E300-33-0-12 L=84 (29.5-54.5)	22x3

E= 35 mm

Art.19225
Art.49225
Art.49225
Art.49250
Art. 06443-31/36-0

1 ANTA
Ap. ESTERNA
1 Sash
Ext. Opening

Contropiastra Regolabile in Metallo			
A-B	C	D	E
06463-32	06465-22	06463-32 (17)	06465-22 (pz.2)
(17) = inserto rullo art. 06141-71			

CILINDRO SAGOMATO (Nichelato Fin.12)		Frontale
con borchie	senza borchie	
0E300-20-0-12 L=89 (29.5-59.5)	0E300-33-0-12 L=84 (29.5-54.5)	22x3

E= 35 mm

Art.19225
Art.49225
Art.49225
Art.49250
Art. 06443-31/36-0

2 ANTE
Ap. ESTERNA
2 Sashes
Ext. Opening

Contropiastra Regolabile in Metallo			
A-B	C	D	E
06463-32	06465-22	06463-32 (17)	06465-22 (pz.2)
(17) = inserto rullo art. 06141-71			

CILINDRO SAGOMATO (Nichelato Fin.12)		Frontale
con borchie	senza borchie	
0E300-20-0-12 L=89 (29.5-59.5)	0E300-33-0-12 L=84 (29.5-54.5)	22x3

E= 35 mm

Art.19225
Art.49225
Art.49225
Art.49250
Art. 06443-31/36-0



1 ANTA
1 Sash

Contropiastra Regolabile in Metallo		
A-B-C	D	E-F
06463-32	06463-22 (17)	06465-22
(17) = inserto rullo art. 06141-71		

CILINDRO SAGOMATO (Nichelato Fin.12)		Frontale
con borchie	senza borchie	22x3
0E300-20-0-12 L=89 (29.5-59.5)	0E300-33-0-12 L=84 (29.5-54.5)	

E= 35 mm

Art. 16205
Art. 16215
Art. 16225
Art. 16217
Art. 16227
Art. 46215
Art. 46225
Art. 46217
Art. 46227
Art. 46230
Art. 46250
Art. 46252
Art. 46210
Art. 46220
Art. 46212
Art. 46222
Art. 06443-00/05-0

2 ANTE
2 Sashes

Contropiastra Regolabile in Metallo		
A-B-C	D	E-F
06463-32	06463-22 (17)	06465-22
(17) = inserto rullo art. 06141-71		

CILINDRO SAGOMATO (Nichelato Fin.12)		Frontale
con borchie	senza borchie	22x3
0E300-20-0-12 L=89 (29.5-59.5)	0E300-33-0-12 L=84 (29.5-54.5)	

E= 35 mm

Art. 16205
Art. 16215
Art. 16225
Art. 16217
Art. 16227
Art. 46215
Art. 46225
Art. 46217
Art. 46227
Art. 46230
Art. 46250
Art. 46252
Art. 46210
Art. 46220
Art. 46212
Art. 46222
Art. 06443-00/05-0

1 ANTA
Ap. ESTERNA
1 Sash
Ext. Opening

Contropiastra Regolabile in Metallo		
A-B-C	D	E-F
06463-32	06463-22 (17)	06465-22
(17) = inserto rullo art. 06141-71		

CILINDRO SAGOMATO (Nichelato Fin.12)		Frontale
con borchie	senza borchie	22x3
0E300-20- 0-12 L=89 (29.5-59.5)	0E300-33- 0-12 L=84 (29.5-54.5)	

E= 35 mm

Art. 16205
Art. 16215
Art. 16225
Art. 16217
Art. 16227
Art. 46215
Art. 46225
Art. 46217
Art. 46227
Art. 46230
Art. 46250
Art. 46252
Art. 46210
Art. 46220
Art. 46212
Art. 46222
Art. 06443-00/05-0

2 ANTE
Ap. ESTERNA
2 Sashes
Ext. Opening

Contropiastra Regolabile in Metallo		
A-B-C	D	E-F
06463-32	06463-22 (17)	06465-22
(17) = inserto rullo art. 06141-71		

CILINDRO SAGOMATO (Nichelato Fin.12)		Frontale
con borchie	senza borchie	22x3
0E300-20- 0-12 L=89 (29.5-59.5)	0E300-33- 0-12 L=84 (29.5-54.5)	

E= 35 mm

Art. 16205
Art. 16215
Art. 16225
Art. 16217
Art. 16227
Art. 46215
Art. 46225
Art. 46217
Art. 46227
Art. 46230
Art. 46250
Art. 46252
Art. 46210
Art. 46220
Art. 46212
Art. 46222
Art. 06443-00/05-0



1 ANTA
1 Sash

Contropiastra Regolabile in Metallo			
A	B	C	Deviatori
06463-32	06463-32	06465-22	06465-22 (pz.2)
(B) Kit rullo art. 06000-00			

CILINDRO SAGOMATO (Nichelato Fin.12)		Frontale
con borchie	senza borchie	
0E300-20-0-12 L=89 (29.5-59.5)	0E300-33-0-12 L=84 (29.5-54.5)	24x3

E= 35 mm

Art. 19526
Art. 49526

2 ANTE
2 Sashes

Contropiastra Regolabile in Metallo			
A	B	C	Deviatori
06463-32	06463-32	06465-22	06465-22 (pz.2)
(B) Kit rullo art. 06000-00			

CILINDRO SAGOMATO (Nichelato Fin.12)		Frontale
con borchie	senza borchie	
0E300-20-0-12 L=89 (29.5-59.5)	0E300-33-0-12 L=84 (29.5-54.5)	24x3

E= 35 mm

Art. 19526
Art. 49526

1 ANTA
Ap. ESTERNA
1 Sash
Ext. Opening

Contropiastra Regolabile in Metallo			
A	B	C	Deviatori
06463-32	06463-32	06465-22	06465-22 (pz.2)
(B) Kit rullo art. 06000-00			

CILINDRO SAGOMATO (Nichelato Fin.12)		Frontale
con borchie	senza borchie	
0E300-20-0-12 L=89 (29.5-59.5)	0E300-33-0-12 L=84 (29.5-54.5)	24x3

E= 35 mm

Art. 19526
Art. 49526

2 ANTE
Ap. ESTERNA
2 Sashes
Ext. Opening

Contropiastra Regolabile in Metallo			
A	B	C	D Deviatori
06463-32	06463-32	06465-22	06465-22 (pz.2)
(B) Kit rullo art. 06000-00			

CILINDRO SAGOMATO (Nichelato Fin.12)		Frontale
con borchie	senza borchie	
0E300-20-0-12 L=89 (29.5-59.5)	0E300-33-0-12 L=84 (29.5-54.5)	24x3

E= 35 mm

Art. 19526
Art. 49526



1 ANTA
1 Sash

Contropiastra Regolabile in Metallo			
A	B	C	Deviatori
06463-22	06463-22	06465-22	06465-22 (pz.2)
(17) = inserto rullo art. 06141-71			

CILINDRO SAGOMATO (Nichelato Fin.12)		Frontale
con borchie	senza borchie	
OE300-20-0-12 L=89 (29.5-59.5)	OE300-33-0-12 L=84 (29.5-54.5)	24x3

E= 35 mm

Art. 16525
Art. 46525

Art. 46550

Art. 46520

2 ANTE
2 Sashes

Contropiastra Regolabile in Metallo			
A	B	C	Deviatori
06463-32	06463-22	06465-22	06465-22 (pz.2)
(17) = inserto rullo art. 06141-71			

CILINDRO SAGOMATO (Nichelato Fin.12)		Frontale
con borchie	senza borchie	
OE300-20-0-12 L=89 (29.5-59.5)	OE300-33-0-12 L=84 (29.5-54.5)	24x3

E= 35 mm

Art. 16525
Art. 46525

Art. 46550

Art. 46520

1 ANTA
Ap. ESTERNA
1 Sash
Ext. Opening

Contropiastra Regolabile in Metallo			
A	B	C	Deviatori
06463-32	06463-22	06465-22	06465-22 (pz.2)
(17) = inserto rullo art. 06141-71			

CILINDRO SAGOMATO (Nichelato Fin.12)		Frontale
con borchie	senza borchie	
OE300-20-0-12 L=89 (29.5-59.5)	OE300-33-0-12 L=84 (29.5-54.5)	24x3

E= 35 mm

Art. 16525
Art. 46525

Art. 46550

Art. 46520

2 ANTE
Ap. ESTERNA
2 Sashes
Ext. Opening

Contropiastra Regolabile in Metallo			
A	B	C	Deviatori
06463-32	06463-22	06465-22	06465-22 (pz.2)
(17) = inserto rullo art. 06141-71			

CILINDRO SAGOMATO (Nichelato Fin.12)		Frontale
con borchie	senza borchie	
OE300-20-0-12 L=89 (29.5-59.5)	OE300-33-0-12 L=84 (29.5-54.5)	24x3

E= 35 mm

Art. 16525
Art. 46525

Art. 46550

Art. 46520



1 ANTA Ap. ESTERNA
1 Sash Ext. Opening

2 ANTE Ap. ESTERNA
2 Sashes Ext. Opening

A

Contropiastra Regolabile in Metallo		Accessori		
A	Deviatori	1/2 Maniglia	Aste	Blocca Aste
06463-32	06465-22 (pz.2)	07070-66-0-B1	-	-
Utilizzare salvaprofilo art. -		Bocchetta Pavimento art. -		
CILINDRO SAGOMATO (Nichelato Fin.12)		Frontale		
con borchie	senza borchie			
0E300-20-0-12 L=89 (29.5-59.5)	0E300-33-0-12 L=84 (29.5-54.5)	24x3		

Art. 43725 Funz. A/D
Art. 43735 Funz. B

E= 40 mm

Maniglione FAST Touch Quadro 8mm
art. 59711-00
art. 59711-01

Quadro Maniglia art. 07085-77-0

Maniglione FAST Push Quadro 8mm
art. 59607-10

Barra Ovale art. 07007-XX

A

Contropiastra Regolabile in Metallo		Accessori		
A	Deviatori	1/2 Maniglia	Aste	Blocca Aste
43295-75	06465-22 (pz.2)	07070-66-0-B1	07088-03	07089-52 (Facoltativo)
Utilizzare salvaprofilo art. -		Bocchetta Pavimento (in dotazione alla contro serratura) art. 06142-85		
CILINDRO SAGOMATO (Nichelato Fin.12)		Frontale		
con borchie	senza borchie			
0E300-20-0-12 L=89 (29.5-59.5)	0E300-33-0-12 L=84 (29.5-54.5)	24x3		

Art. 43725 Funz. A/D
Art. 43735 Funz. B

E= 40 mm

Maniglione FAST Touch Quadro 8mm
art. 59711-00
art. 59711-01

Quadro Maniglia art. 07085-77-0

Maniglione FAST Push Quadro 8mm
art. 59607-10

Barra Ovale art. 07007-XX

A Bocchetta Superiore

Art. 06141-80

B Boccola

Art. 06147-01

C Blocca Aste

Art. 07089-52

A Aste

Art. 07088-03

Sezione Verticale - Riarmo Manuale
Vertical section - Manual reset

A Bocchetta Superiore

Art. 06141-80

B Boccola

Art. 06147-01

C Blocca Aste

Art. 07089-52

A Aste

Art. 07088-03

Sezione Verticale - Riarmo Automatico
Vertical section - Automatic reset



**MANIGLIONI ANTIPANICO
APPLICARE FAST**
APPLY FAST PANIC BARS

MANIGLIONI ANTIPANICO APPLICARE FAST

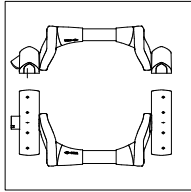
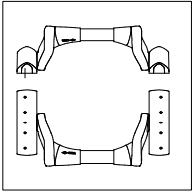

- FAST PUSH**
- 59001-10-0
 - 59011-10-0
 - 59016-10-0

- Barra Ovale**
- 07007-14-0 (acciaio verniciato)
 - 07007-61-0 (inox)

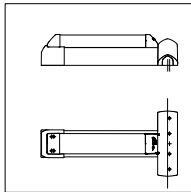
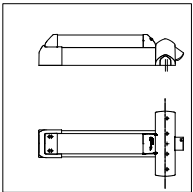

- FAST TOUCH (L=1200)**
- 59801-10-0
 - 59811-10-0
 - 59816-10-0

- FAST TOUCH (L=840)**
- 59801-09-0
 - 59811-09-0
 - 59816-09-0

- eFAST**
- 59851-10-0

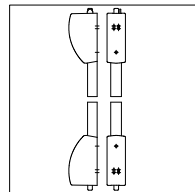
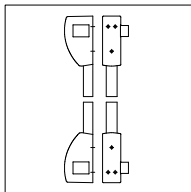
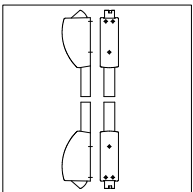

Coppia Alto Basso
07063-61-0

Coppia Laterale
07063-51-0

Coppia Catenacci
07063-71-0

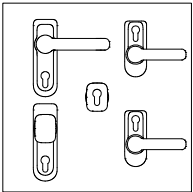

- Comandi Esterni**
- 07078-68-0
 - 07078-69-0
 - 07078-38-0
 - 07078-36-0
 - 07078-35-0

Accessori

- Kit P. prolunga 07064-51-0
- Incontro Laterale 07072-11-0
- Micro Fast Touch 06195-05-0
- Micro Fast Push 06195-06-0
- Micro Comando Est. 06195-10-0
- Passacavo 06515-21-0
- Ingegno 06198-70-0

1 ANTA Apertura ESTERNA

1 Sash Ext. Opening

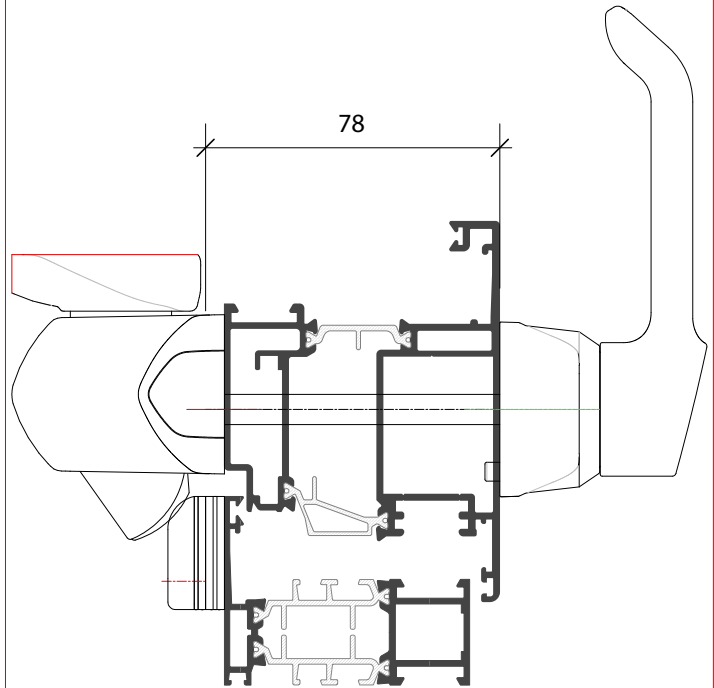

2 ANTE Apertura ESTERNA

2 Sashes Ext. Opening

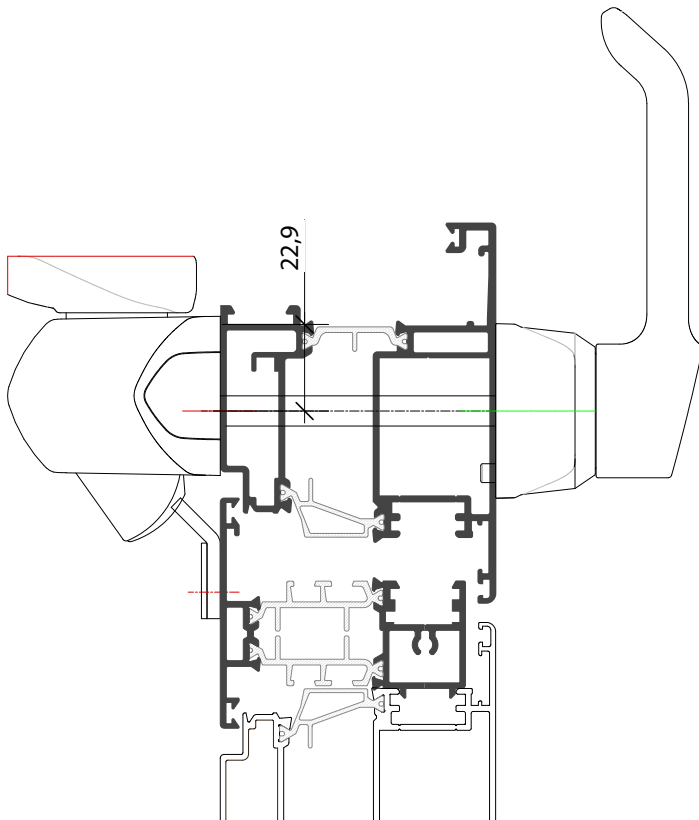

Sezione Verticale

Vertical section

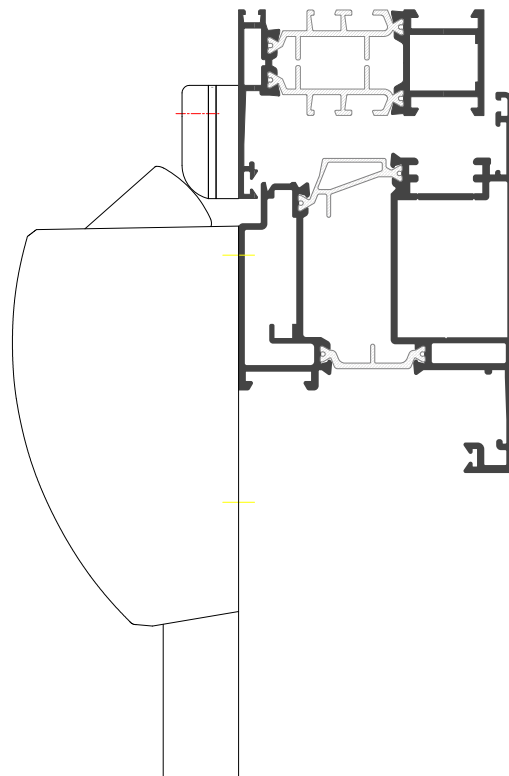



MANIGLIONI ANTIPANICO APPLICARE FAST
Sezione Pavimento
APPLY FAST PANIC BARS
Floor Section

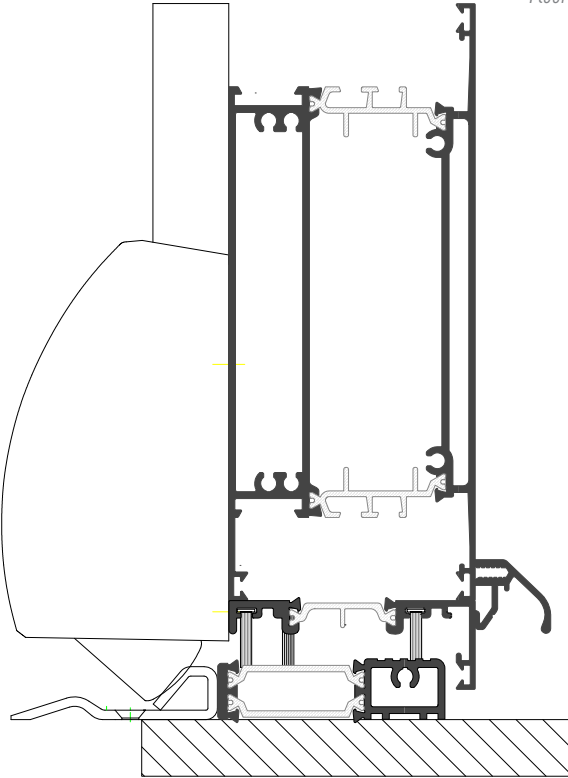

Gli archivi digitali dei prodotti TWIN SYSTEMS
sono disponibili nei formati:

*The digital files of the TWIN SYSTEMS
products are available in the formats at:*



www.twinsystems.it/web/richiesta-dwg

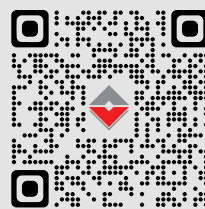

Il presente Catalogo assieme ai cataloghi di tutti i
prodotti TWIN SYSTEMS sono liberamente scaricabili:

*This Catalog together with the catalogs of all TWIN SYSTEMS
products can be downloaded freely at:*

www.twinsystems.it/professionisti/cataloghi/

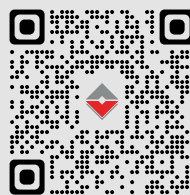

PAGINA Cataloghi
CATALOGUES Webpage

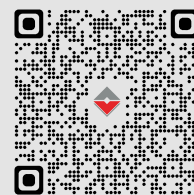

LINEA PRODOTTI
PRODUCTS Line

PAM SYSTEM S.r.L.

S.S. 230 - Fornace Crocicchio 13030 Formigliana (VC)
Tel. 0161 858811 - Fax 0121 858800
www.pamsystemsrl.com | info@pamsystemsrl.com

ALQ GENOVA s.r.l.

Direzione & Magazzino

Via Colano, 9/A 12/K 16162 Genova Bolzaneto (GE)
Tel. 010 7491941 - Fax 010 7450155

Magazzino

Via Meucci, 25 Calenzano 50041 (FI)
Tel. +39 055 8825060 Fax: +39 055 8824916
www.alqsystem.it | info@alqgenovasrl.com

PAESANI GROUP

Direzione & Magazzino

Via del Grano, 260 47822 Santarcangelo di Romagna (RN)
Tel. 0541 748511

www.paesani.com | info@paesani.com

Magazzino Nord

Via Luigi Bonati, 21 29017 Fiorenzuola d'Arda (PC)
Tel. 0523 943138
magazzinonord@paesani.com

DIVA s.a.s

Via Po, 25 - Z.I. Sambuceto 66020 S.Giovanni Teatino (CH)
Tel. 085 4405210 - Fax 085 4405207

www.camel-diva.com | info@camel-diva.com

EUROALL S.r.l.

Strada Comunale della Mola Saracena, 23 00065 Fiano Romano (RM)

Tel. 0765 455228/61 - Fax 0765 455317

www.euroallslrl.it | info@euroallslrl.it

PROFILATI UMBRIA S.r.l.

Via Dei Tigli, 35 - 06083 Bastia Umbra (PG)
Tel. 075 8012385 | 075 8010328 - Fax 075 8012386
info@profilatiumbria.it

TSL ALLUMINIO S.r.l.

Via delle Industrie, 12 00030 San Cesario (Roma)
Tel. 06 2251591 (Ric. Aut.) - Fax 06 2280693
www.tslalluminio.it | info@tsllalluminio.it

ALLCAR SERVICE S.r.l.

Via Acuto, 120 - 00131 Roma
Tel. 06 4130626 (Ric. Aut.) - Fax 06.4130367
www.allcarservice.it | allcarservice@mlclink.it

ALLUCOM S.r.l.

Andria

Via Vecchia Barletta 237 Z. Ind. - 76123 Andria (BT)
Tel. 0883 592213 - Fax 0883 552386

Bari

Via Zippitelli, 28/B - 70123 (BA)
Tel. 0805058608 - Fax 0805058607
www.allucom.com | info@allucom.com

CARUSO S.r.l.

Z.I. Contrada Le Macere 86019 Vinchiatturo (CB)
Tel. 0874 340024 - Fax 0874340025
carusosrl1@libero.it

CAIMAR S.n.c.

Direzione & Magazzino

Strada Prov.le Rimedio-Torregrande Km. 4
09072 Cabras (OR) - Tel. 0783 290118

Filiale

Fronte S.S. 131 Km. 17,450 - 09023 Monastir (CA)
Tel. 070 9166020 - Fax 070 9166191
www.caimar.it | caimarmail@caimar.it

SALENTO METALLI S.r.l.

Via Federico II, 13 - Zona PIP - 73020 Cavallino (LE)
Tel. 0832 614576 - Fax 0832 614635
www.salentometalli.it | info@salentometalli.it

MIDA ALLUMINIO S.r.l.

Napoli

Via Piano del Principe, 36
80047 San Giuseppe Vesuviano (NA)
Tel. 081 5297373 - Fax 081 8284449

Salerno

Loc. Terzerie, Z.I. - 80061 Ogliastro Cilento (SA)
Tel. 0974 833233 - Fax 0974 844724
www.gruppomida.it | info@gruppomida.it

ITALBACOLOR S.r.l.

C.da Valle S. Maria - 87024 Fuscaldo (CS)
Tel. 0982 618025 - Fax 0982 720235
www.italbacolor.it | commerciale@italbacolor.it

COMAS S.r.l.

Via Porta Palermo, 84 - 91011 Alcamo (TP)
Tel. 0924 507050 - Fax 0924 507051
www.comasgroup.it | info@comasgroup.it

ALUK TIM

Aluk Tim D.o.o.

Žegoti 10, 51215 Kastav Croazia, UE
Tel: +385 (0) 51/691 461 - Fax: +385 (0) 51/691 473

Filiale di Zagabria

Franje Lučića, 34A Zagabria Croazia, UE
Tel: +385 (0) 1 6462 611 - Fax: +385 (0) 1 6462 610
Mob: +385 (0) 99 2939656
zagreb@aluk.hr

Filiale Spalato

Street Sv. Nikole Tavelića, 13A 21204
Dugopolje Croazia, UE
Tel: +385 (0) 21225525
Fax: +385 (0) 21660110
Mob: +385 (0) 99 2199228
split@aluk.hr



  www.twinsystems.it
info@twinsystems.it

Consorzio **TWIN SYSTEMS**
Via delle Macere, 20 | 00060 Formello [Roma]
Tel./Fax 06 23260298